

MONTAGEINSTRUKTIONEN

Tagesbett

SKU : N636P171606
N636P171607
N636P171608

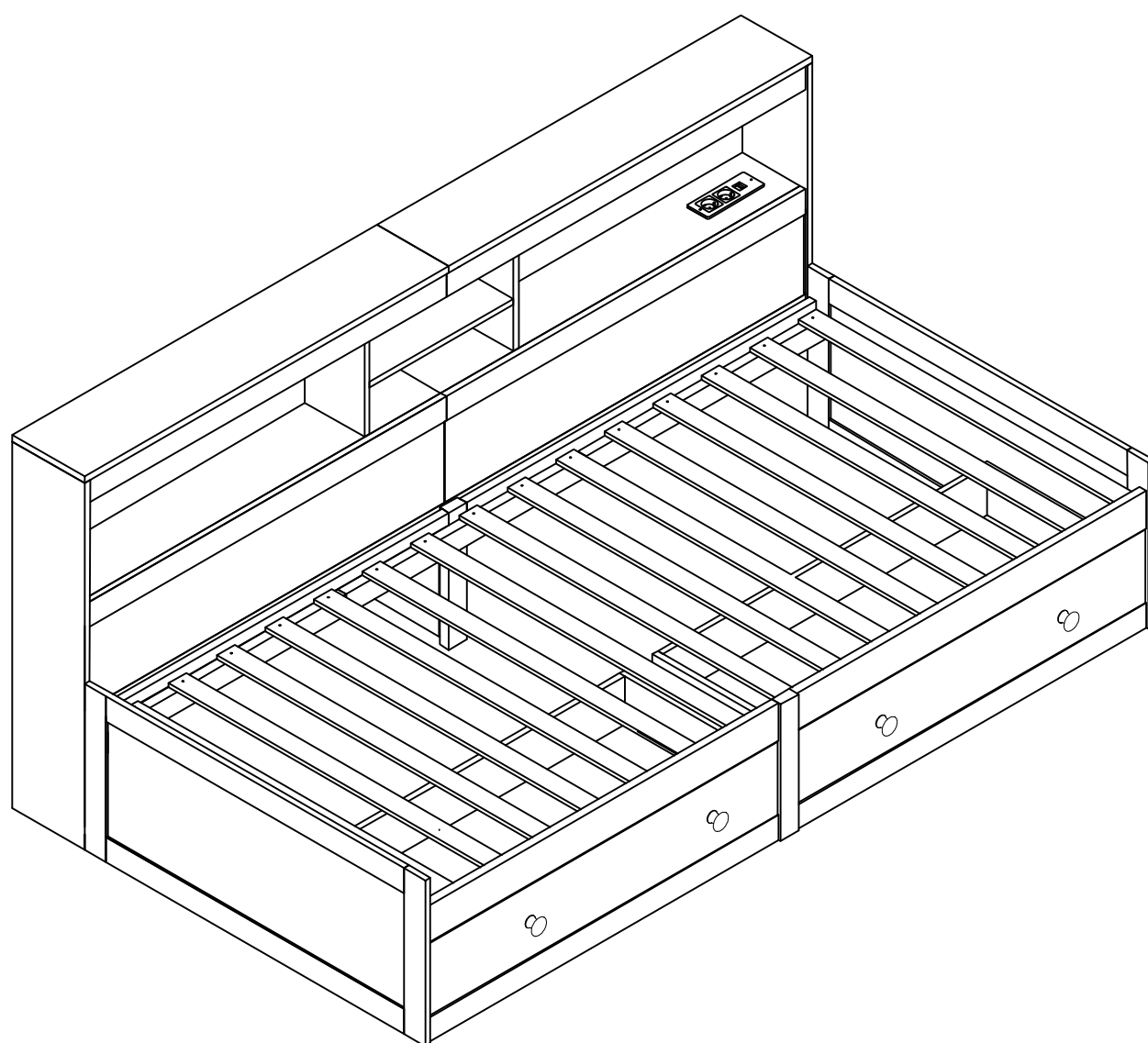

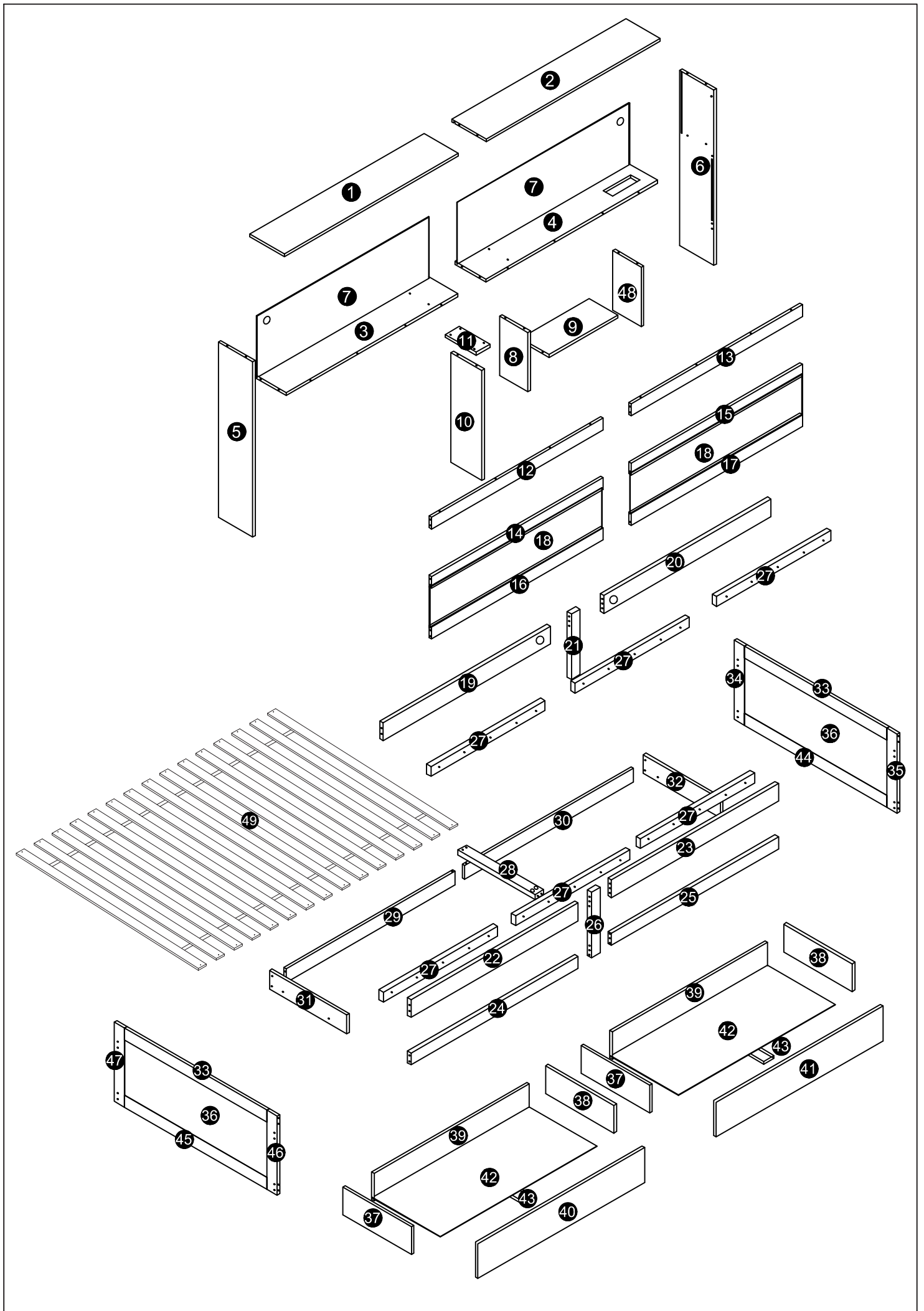

N636P171606

1 x1

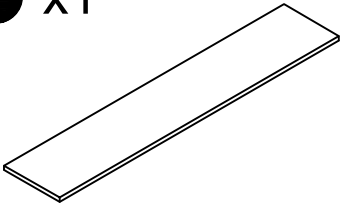

2 x1

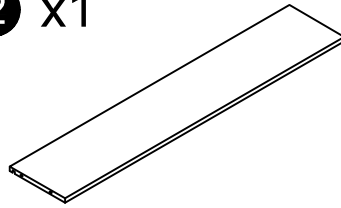

4 x1

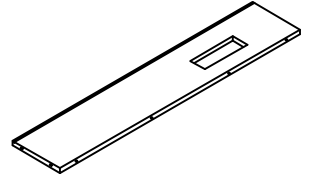

12 x1

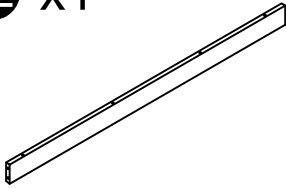

13 x1

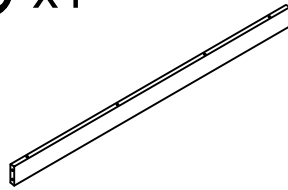

14 x1

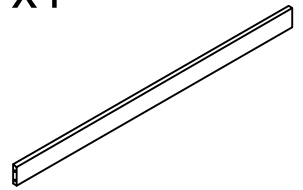

15 x1

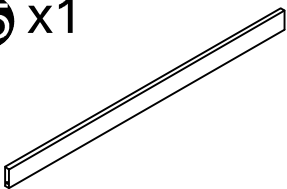

16 x1

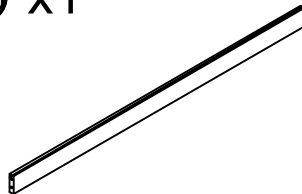

17 x1

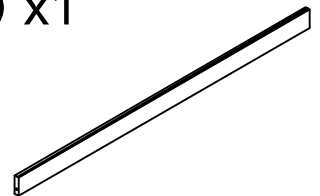

18 x2

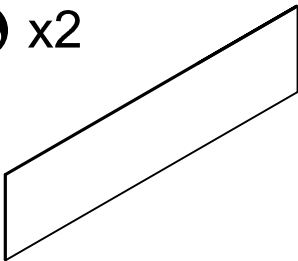

29 x1

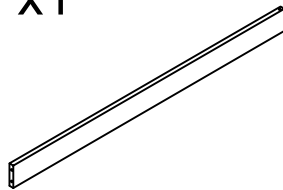

30 x1

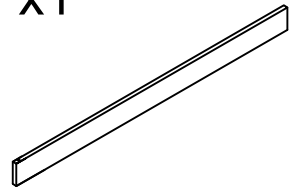

44 x1

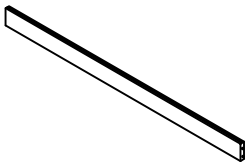

N636P171607

3 x1

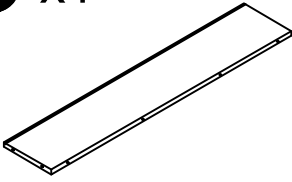

7 x2

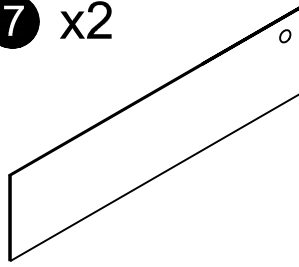

21 x1



26 x1



27 x6

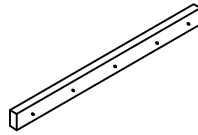

28 x1

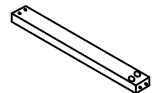

34 x1



35 x1



37 x2

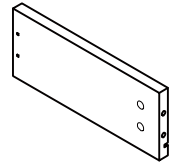

38 x2

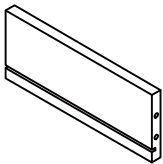

43 x1

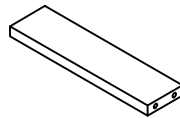

49 x1

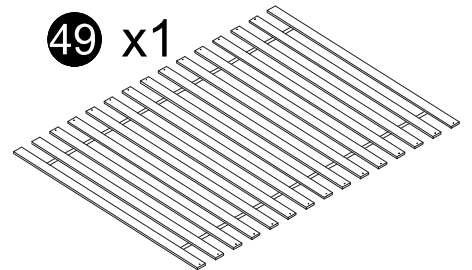





47 x1

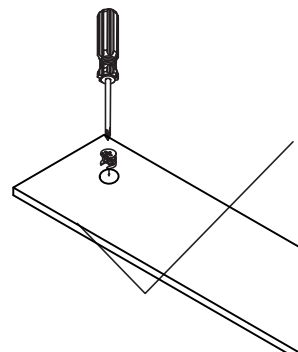
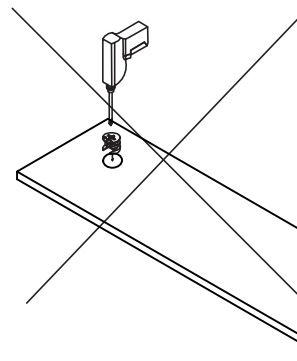
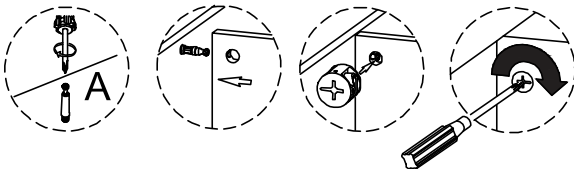



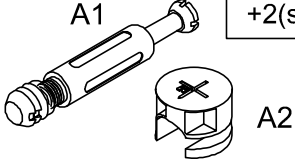
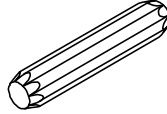
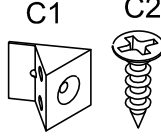
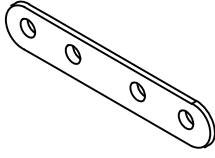
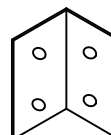
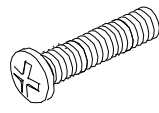

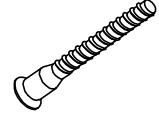
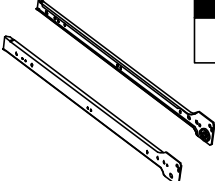
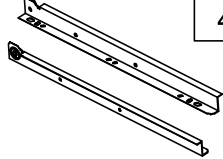

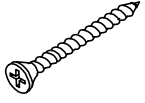
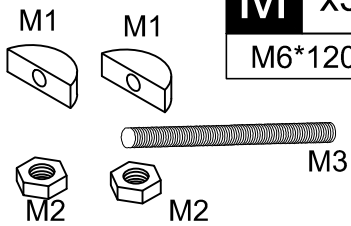
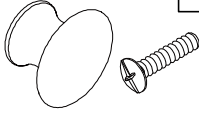
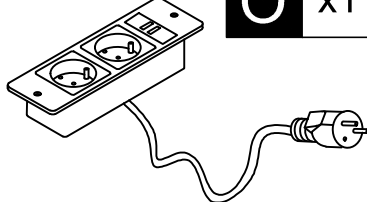
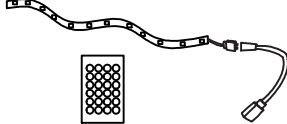
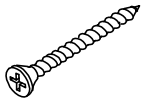
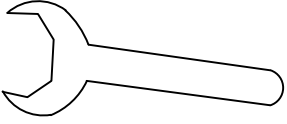
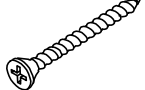

46 x1

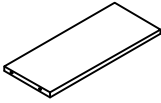

N636P171607

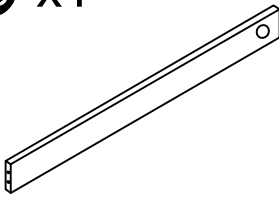
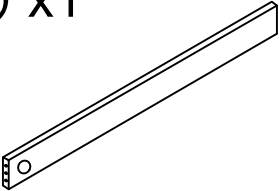
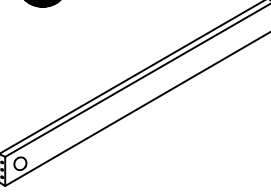
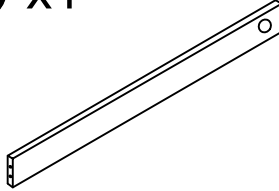
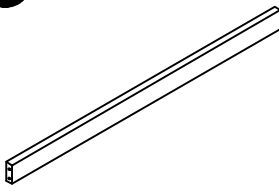
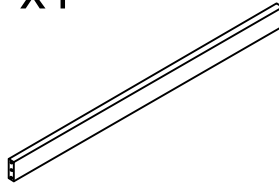
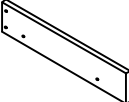
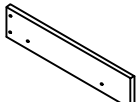
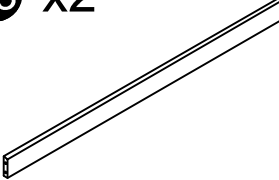
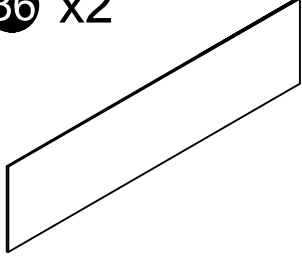

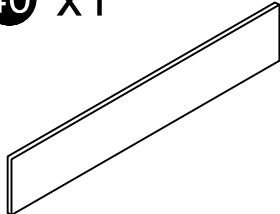
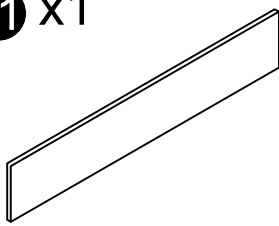
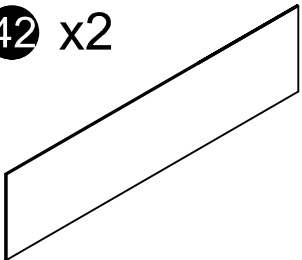
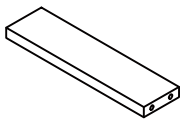
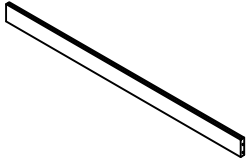
 <p>A x68 +2(spare)</p>	 <p>B x18 M8*40 +2(spare)</p>	 <p>C x8 M3*14 +2(spare)</p>
 <p>D x4</p>	 <p>E x2</p>	 <p>F x4 M6*25</p>
 <p>G x1</p>	 <p>H x1</p>	 <p>I x14 M7*50 +1(spare)</p>
 <p>J1 x2 400mm</p>	 <p>J2 x2 400mm</p>	 <p>K x38 M3.5*14 +2(spare)</p>
 <p>L x68 M3.5*35 +2(spare)</p>	 <p>M x3 M6*120</p>	 <p>N x4 M4*18</p>
 <p>O x1</p>	 <p>P x1</p>	 <p>Q x4 M3.5*20</p>
 <p>R x1</p>	 <p>S x16 M4*100 +1(spare)</p>	

N636P171608

5 x1 	6 x1 	8 x1 	9 x1 
10 x1 	11 x1 	19 x1 	20 x1 
22 x1 	23 x1 	24 x1 	25 x1 
31 x1 	32 x1 	33 x2 	36 x2 
39 x2 	40 x1 	41 x1 	42 x2 
43 x1 	45 x1 	48 x1 	

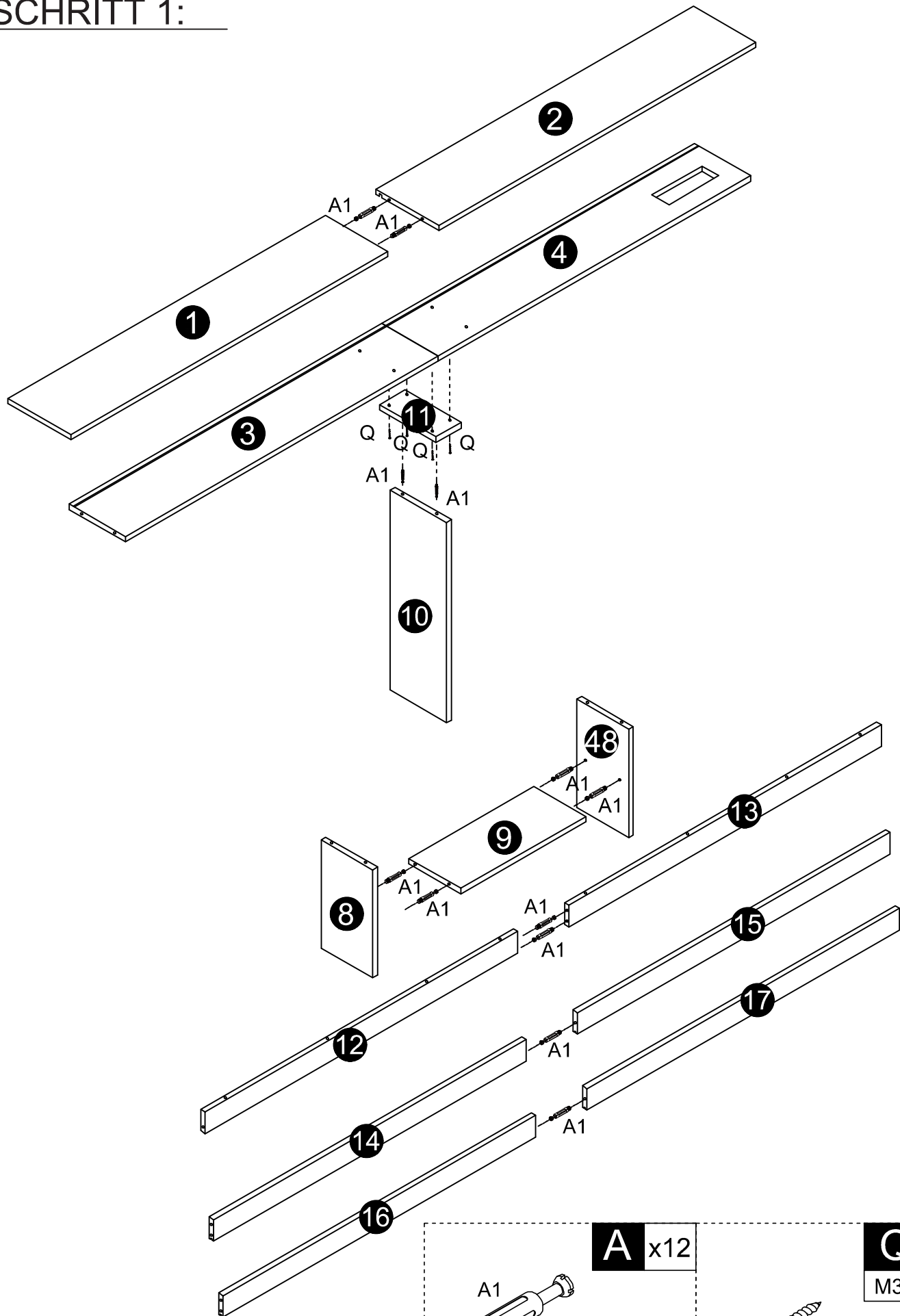
SCHRITT 1:

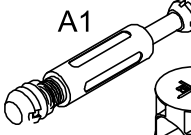

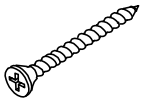
 A1	A x12	 A2	 Q x4 M3.5*20
---	--------------	---	--

SCHRITT 2:

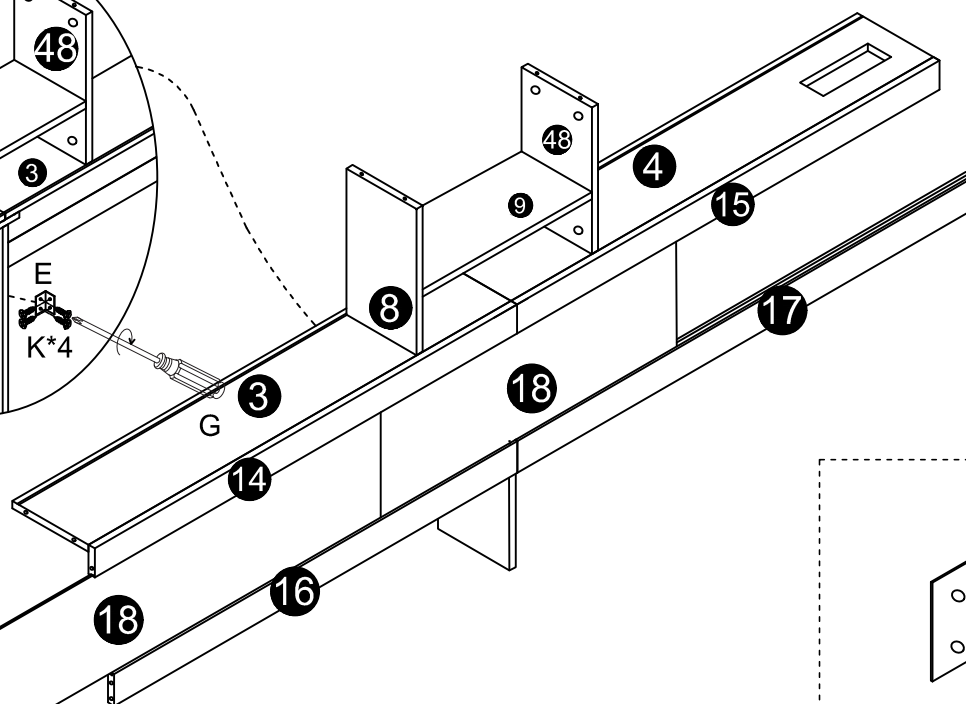
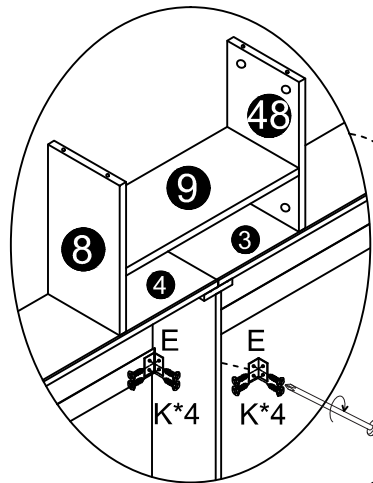
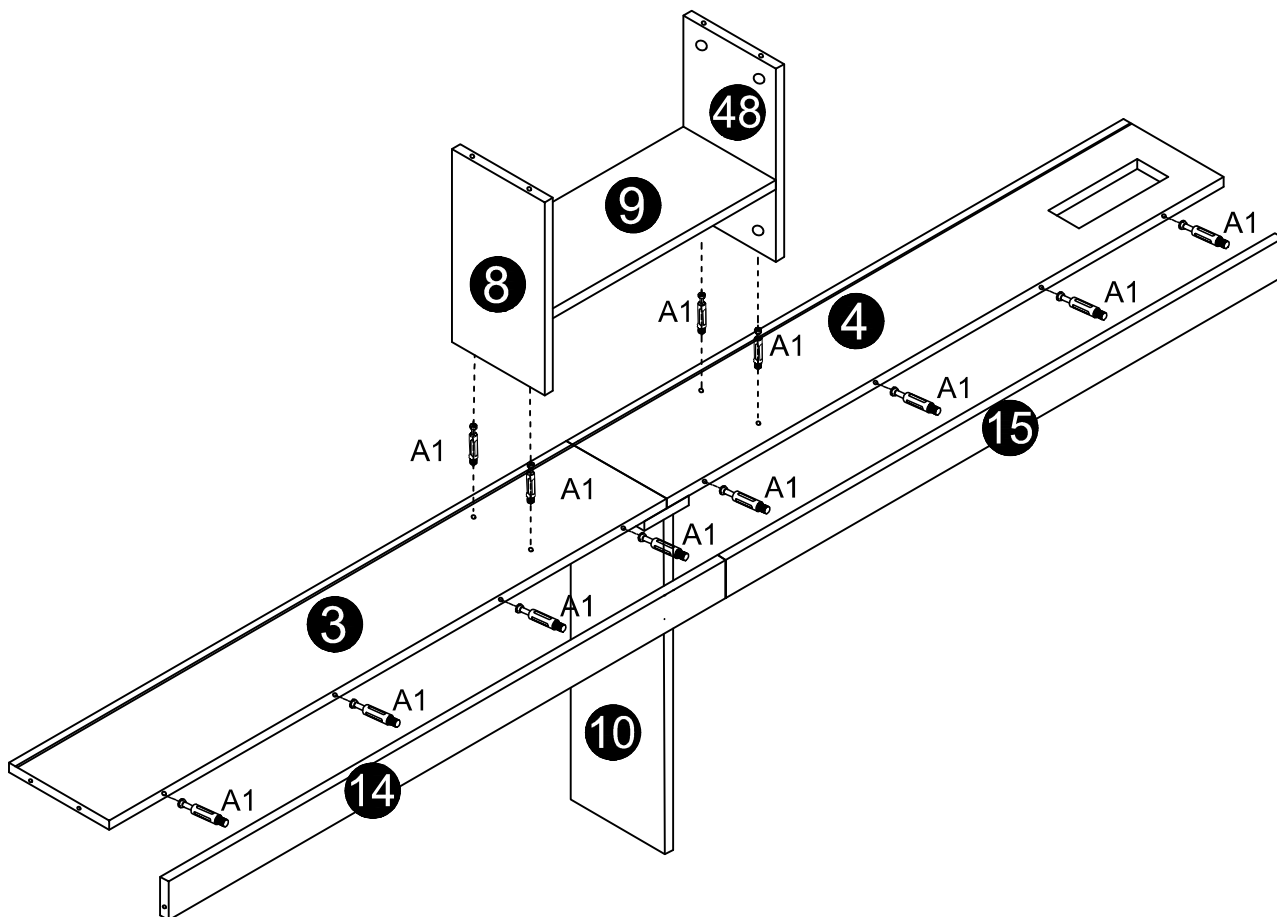

E x2

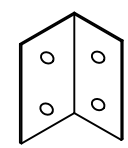

G x1

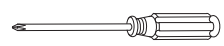

K x8
M3.5*14



A x12

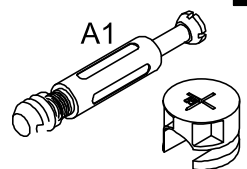

SCHRITT 3:

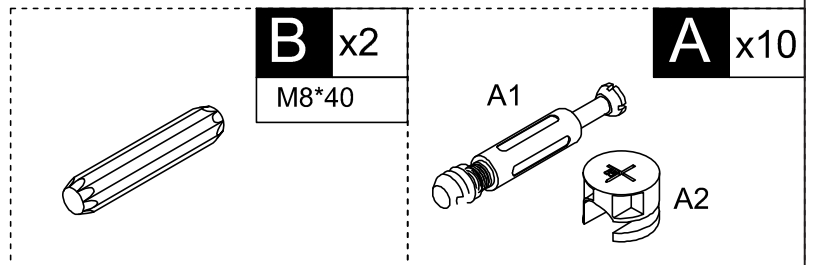
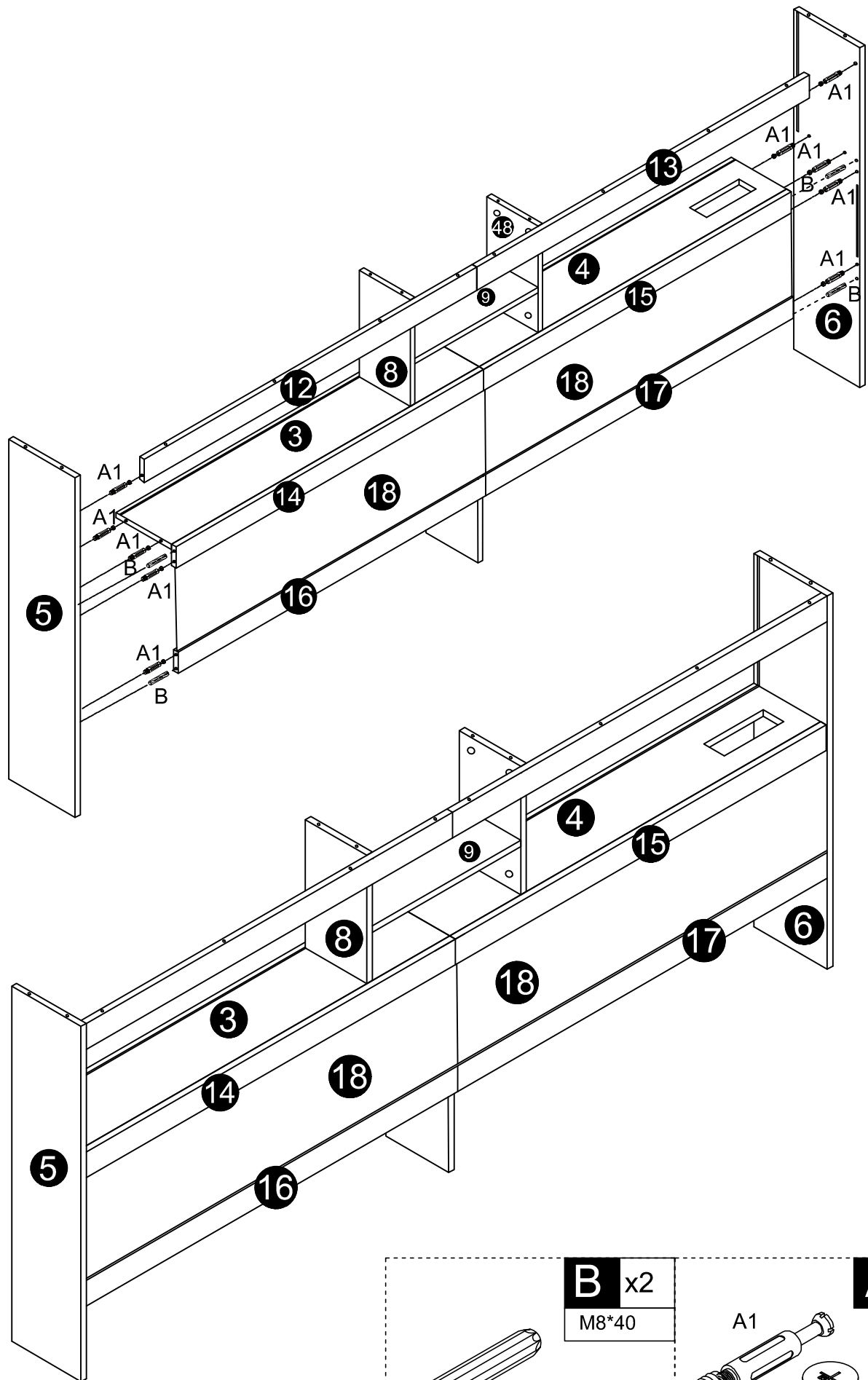

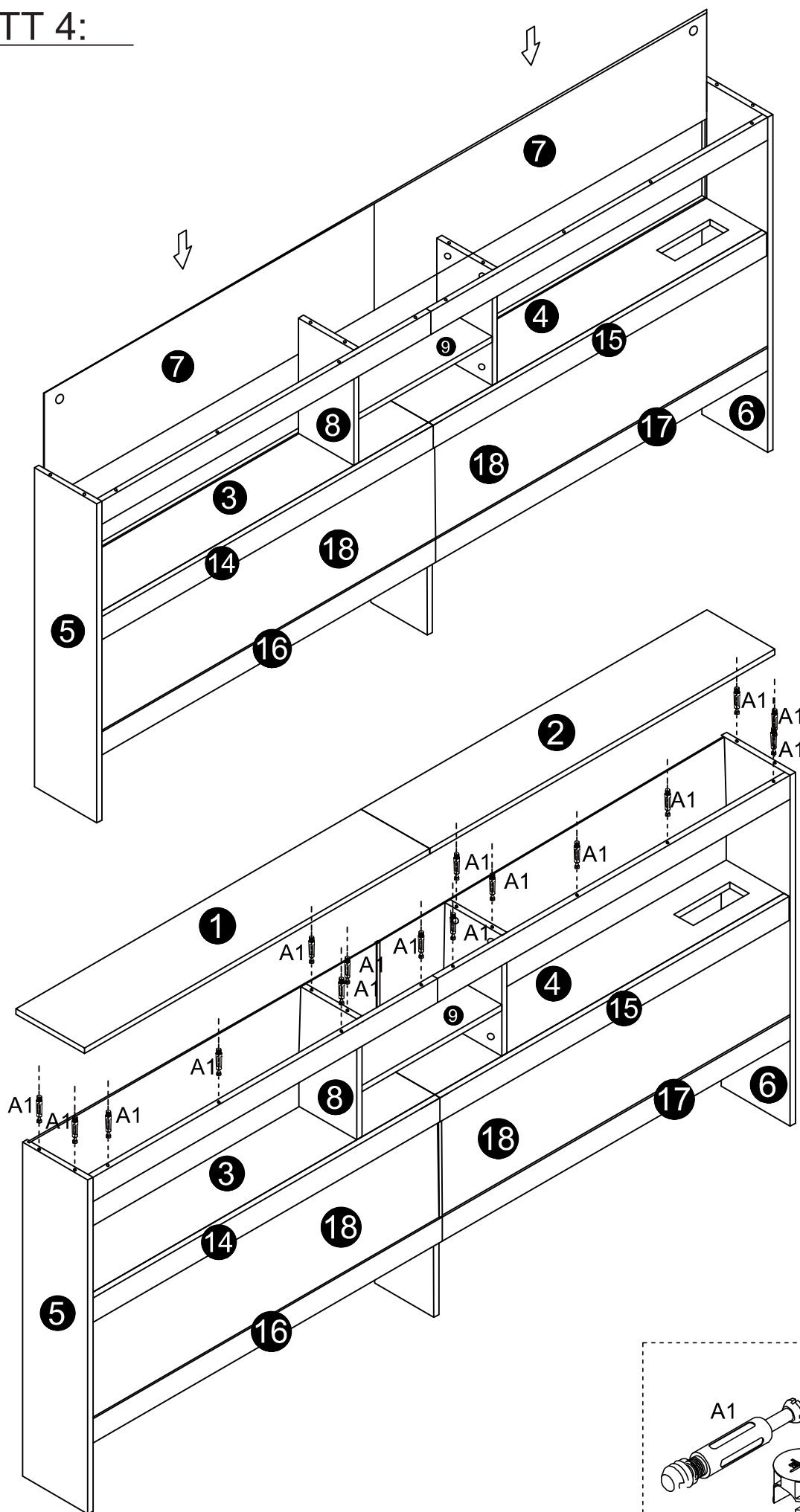

SCHRITT 4:

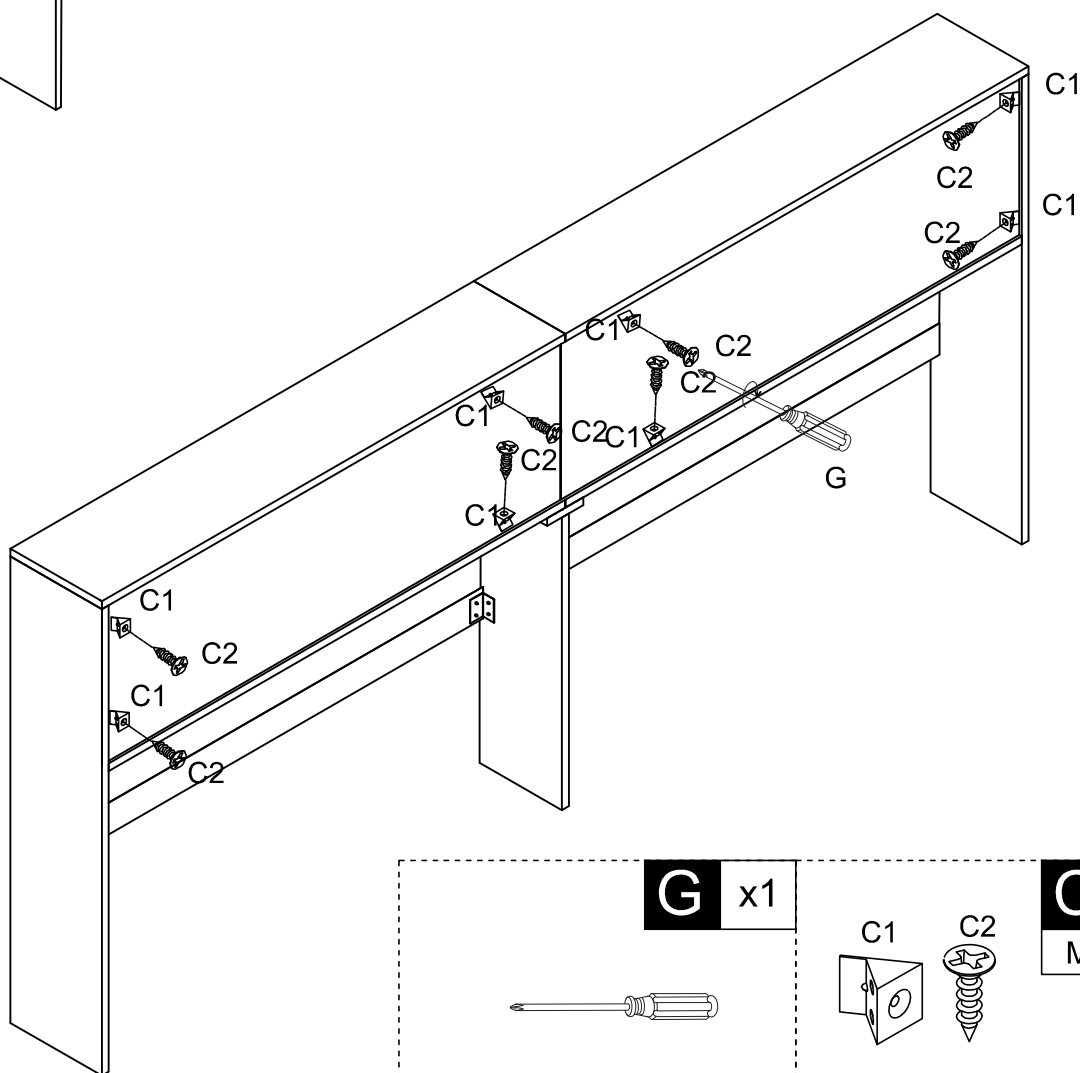
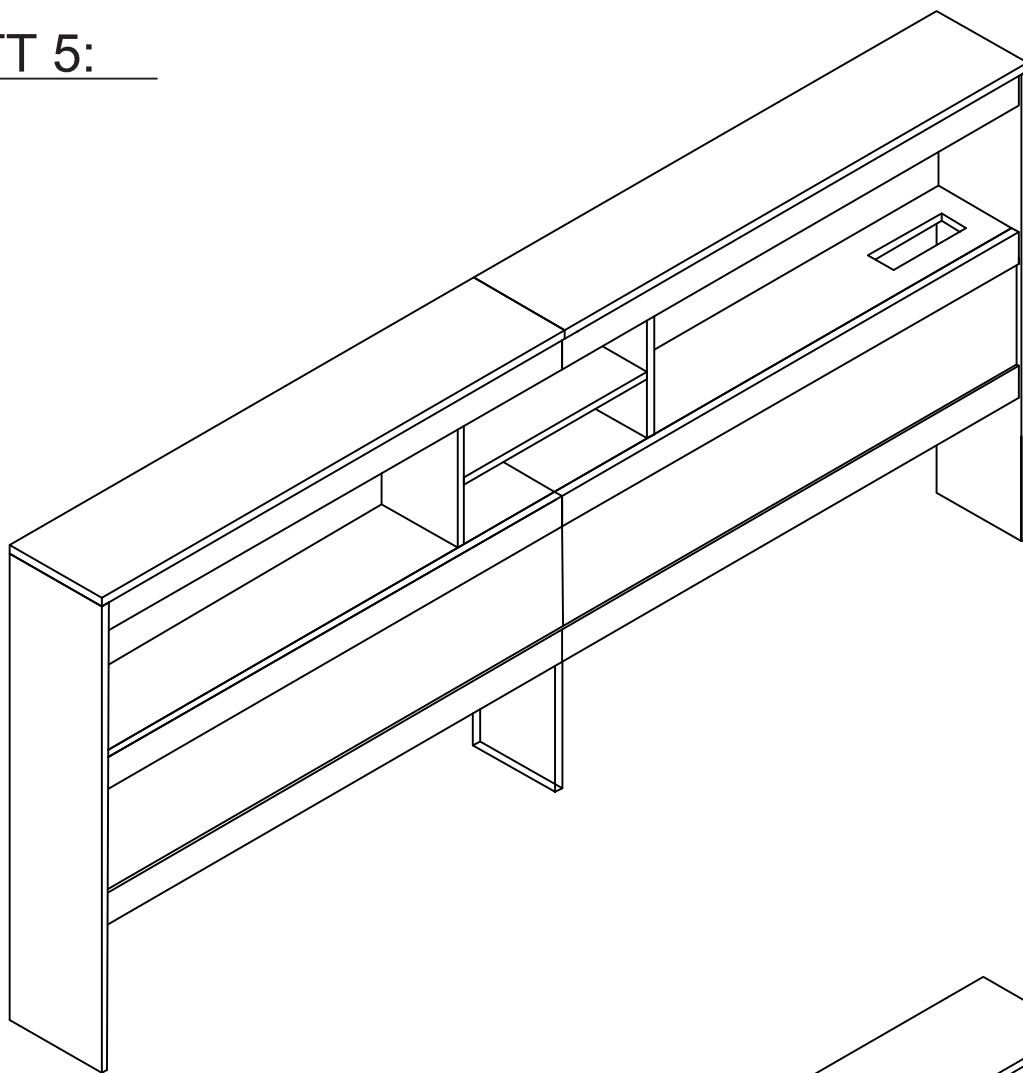

SCHRITT 5:

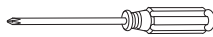

G x1	C x8
	 
	M3*14

SCHRITT 6:

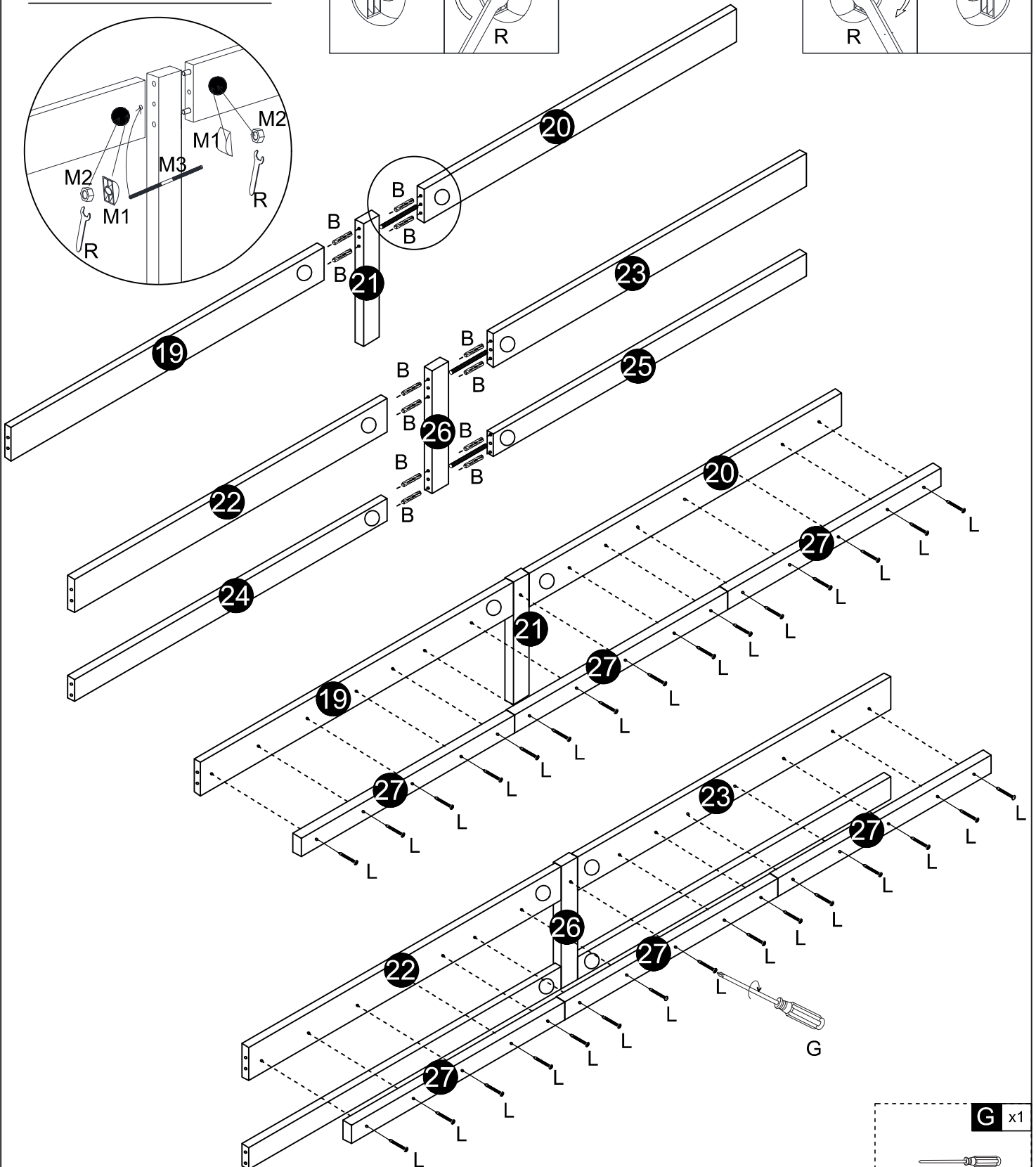
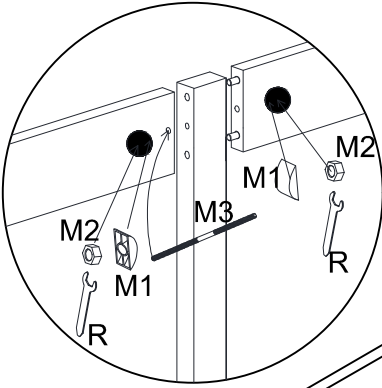
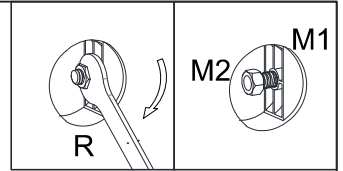
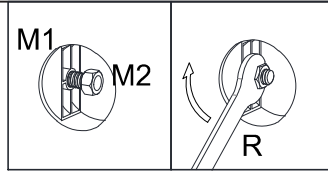

Man beachte die unterschiede zwischen den zähnen der nr. 21 und der nr. 26 innen und außen. Als die montage fertig war, wurden die teller 21 mit den platten 19 und 20 ebenerdig und die teller 26 mit den platten 22 und 23 24 und 25.

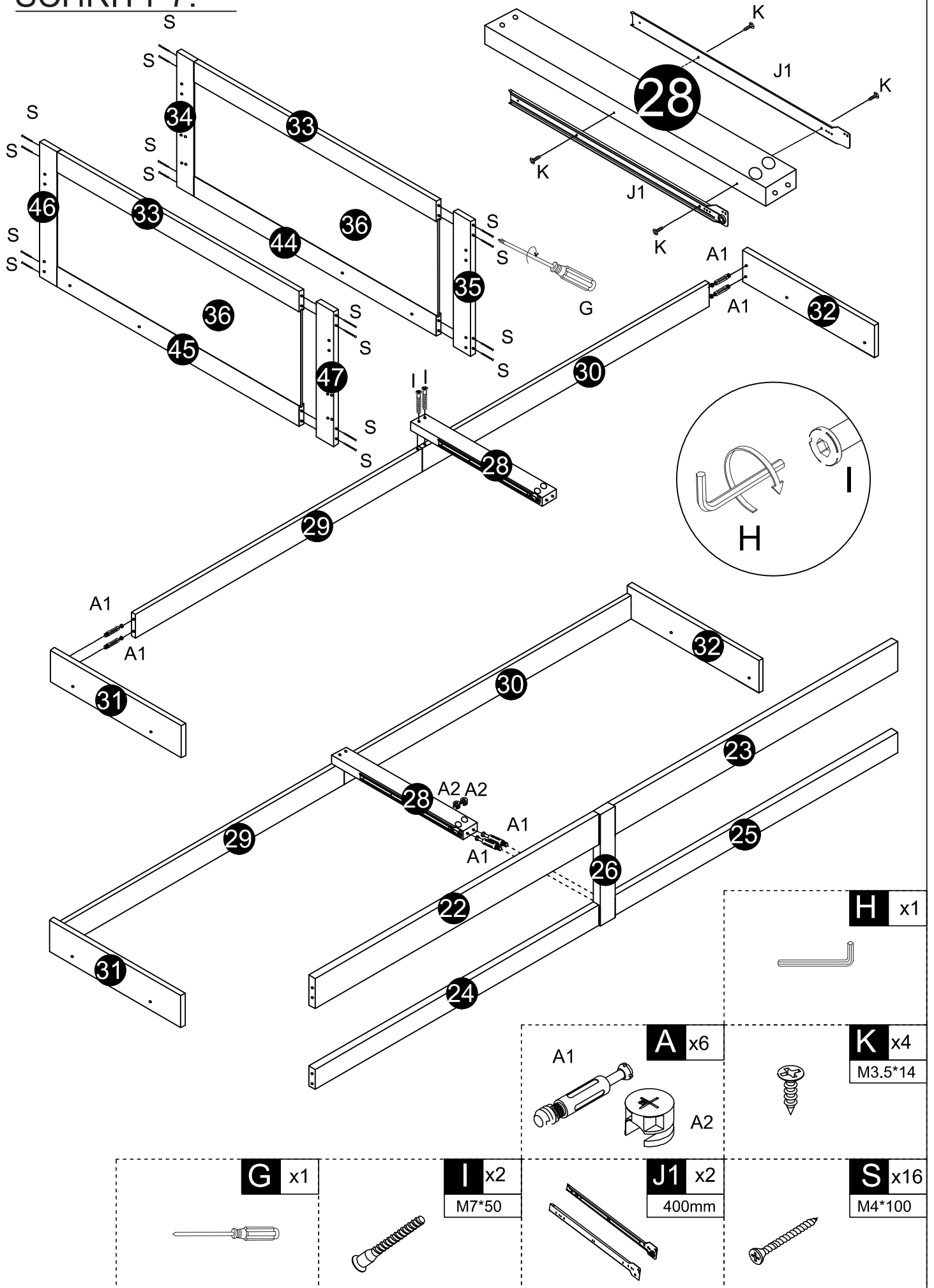

G x1		M x3	
L x30	M1	M1	M3
B x12	M2	M2	R x1
M8*40			

SCHRITT 7:



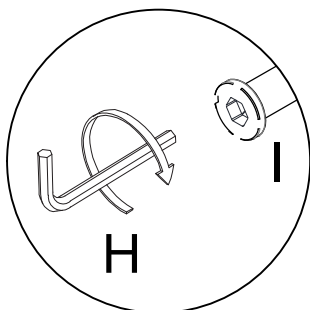
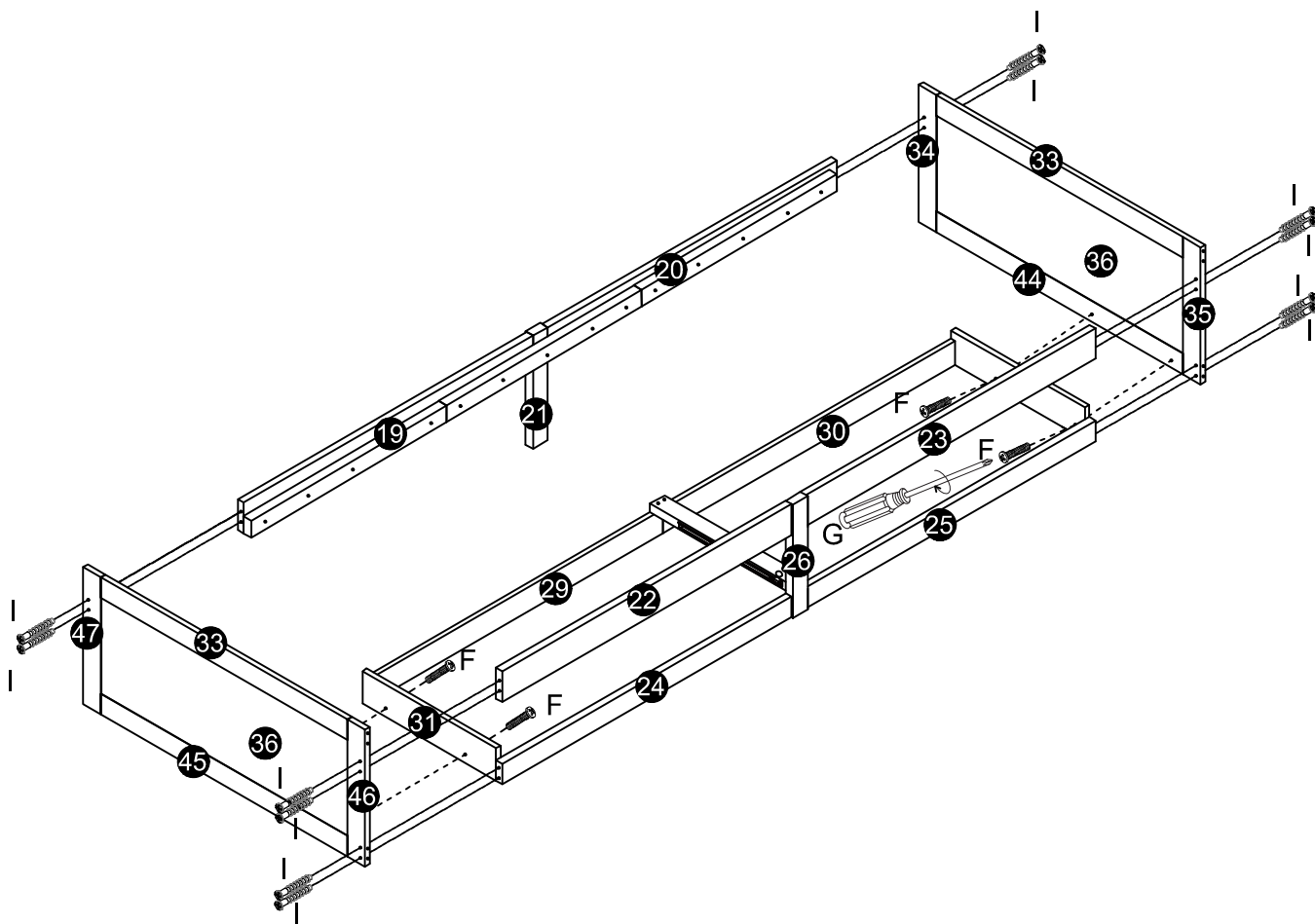



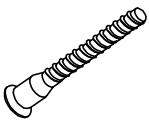
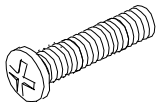

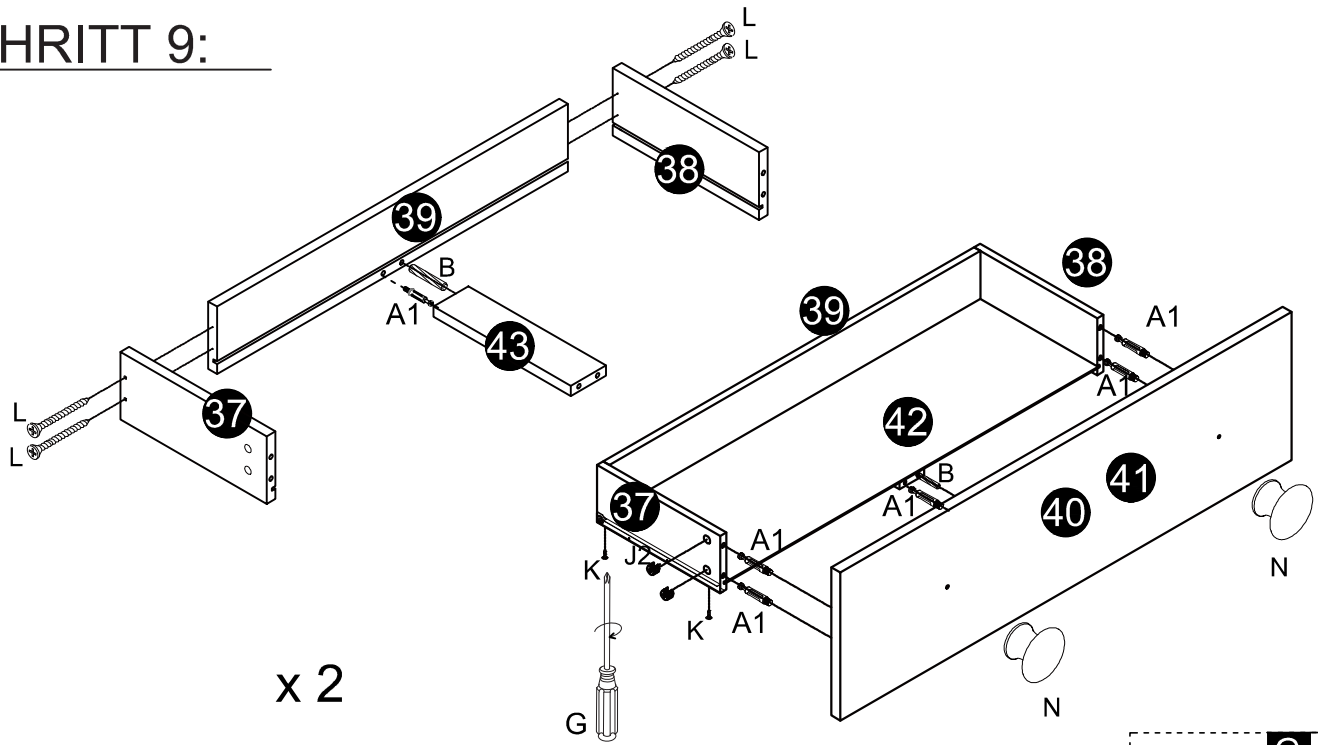

SCHRITT 8:

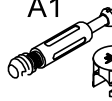

<p>G x1</p> 	<p>H x1</p> 
<p>I x12 M7*50</p> 	<p>F x4 M6*25</p> 

SCHRITT 9:



- 
N x4
M4*18
- 
B x4
M8*40
- 
J2 x2
400mm
- 
A1 **A2**
- 
A x12
- 
K x8
M3.5*14
- 
L x8
M3.5*35
- 
G x1

SCHRITT 10:

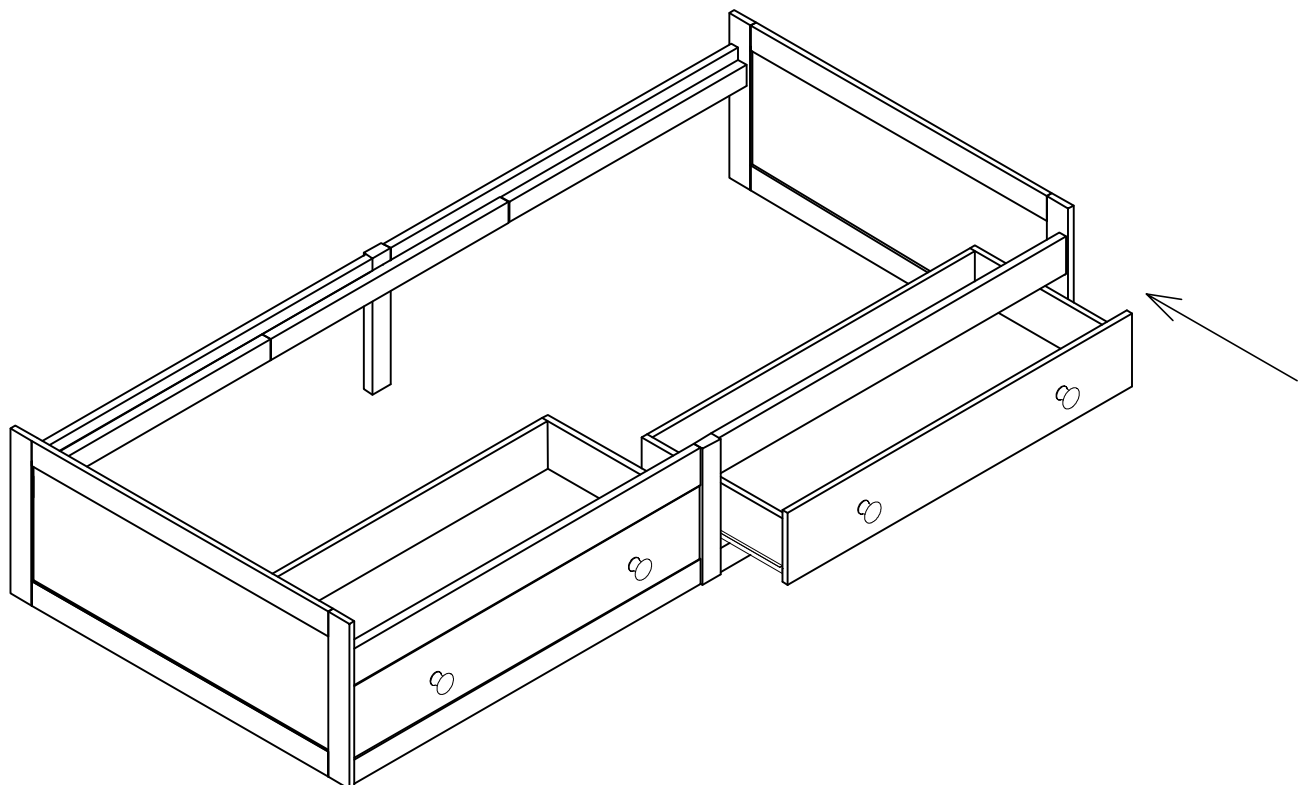

SCHRITT 11:

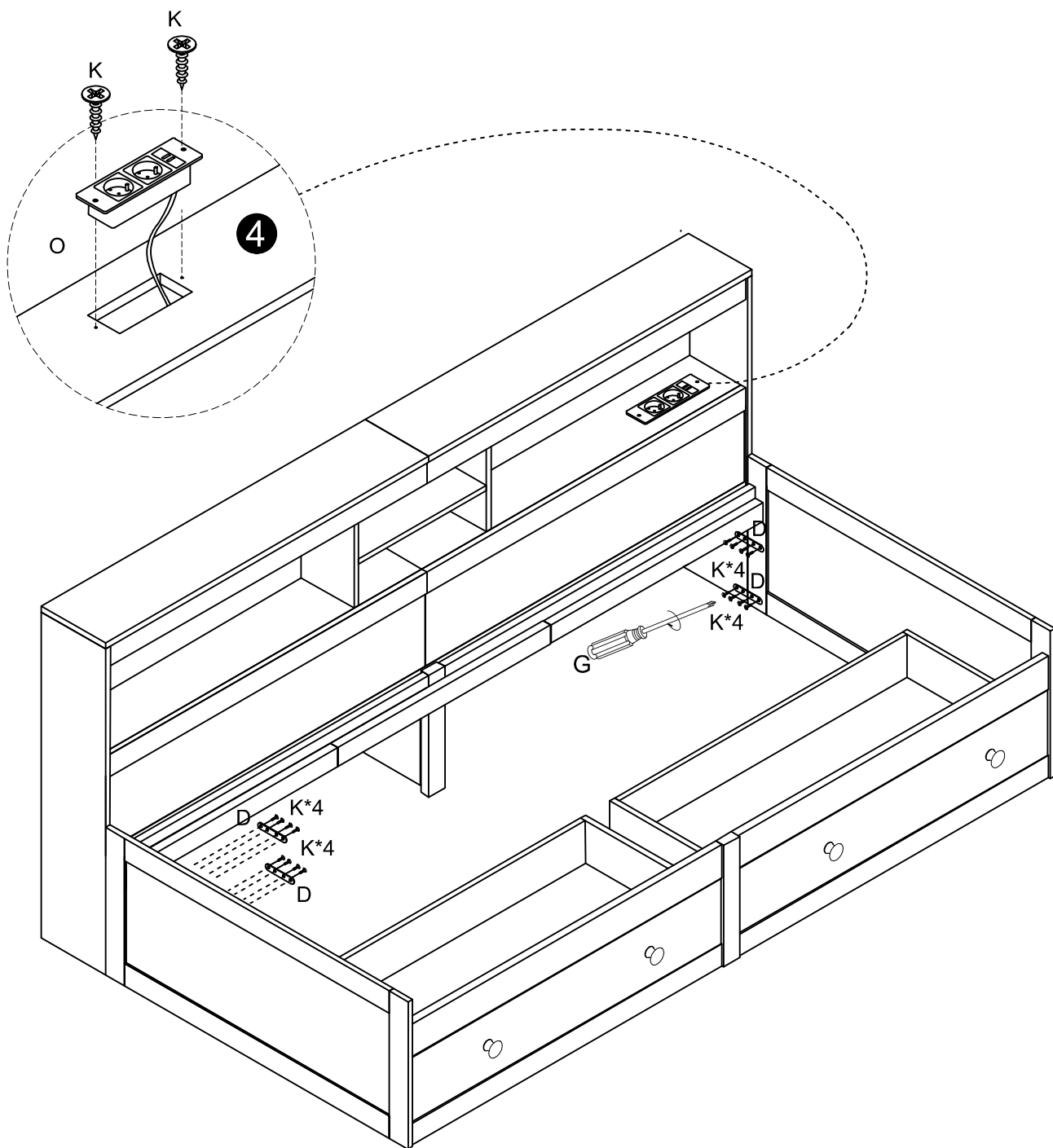

G x1

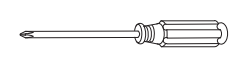

O x1

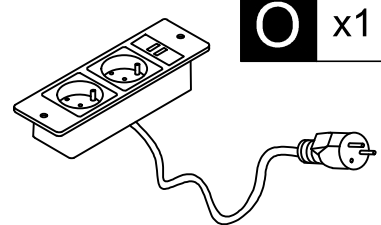

K x18
M3.5*14



D x4

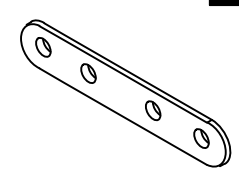

SCHRITT 12:

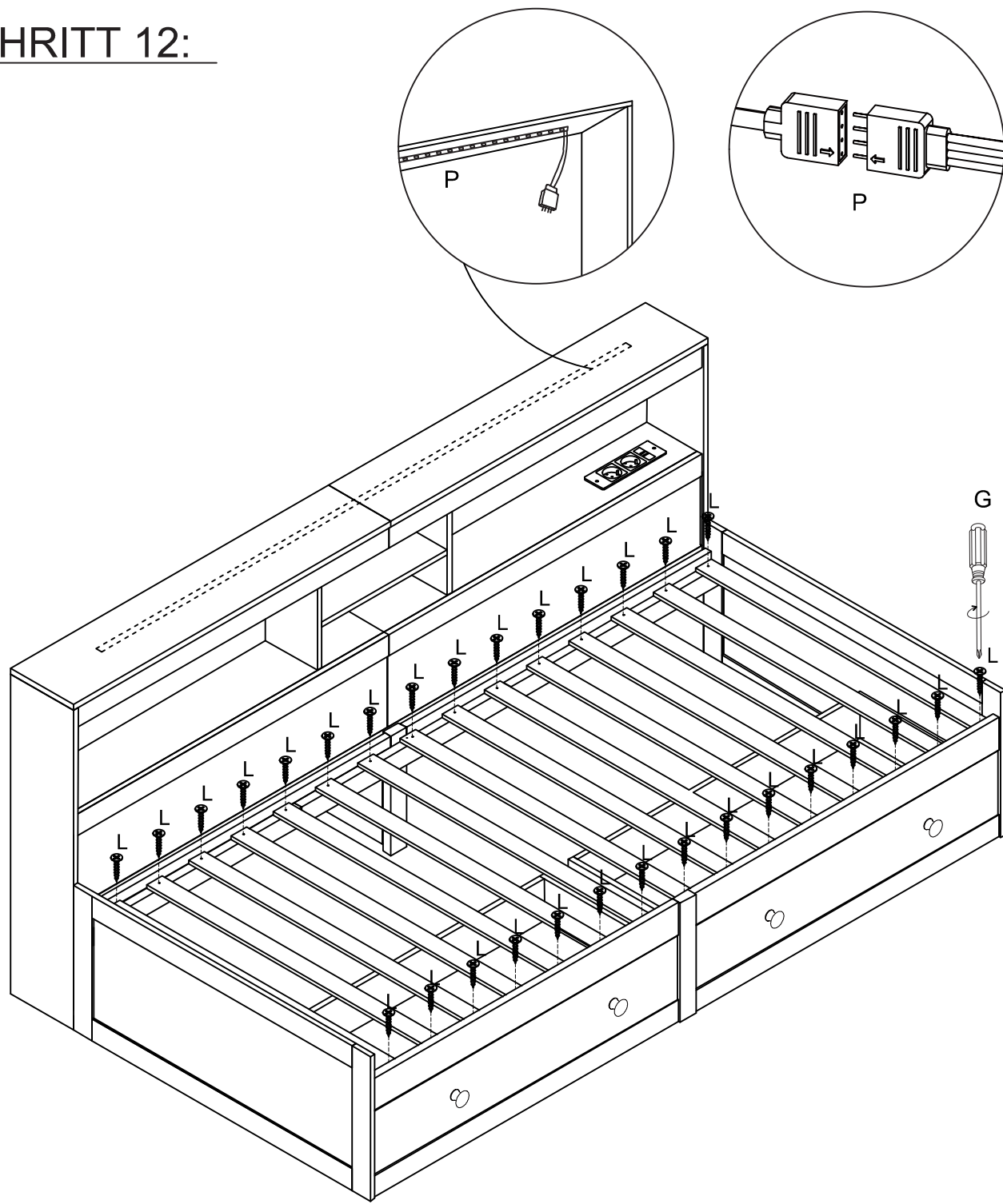

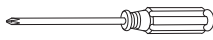
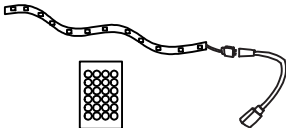
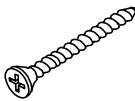
<p>G x1</p> 	<p>P x1</p> 	<p>L x30 M3.5*35</p> 
--	---	---