

# Soma

by Morten Georgsen

Model	Colour/Farbe/Couleur	
412134	231	Granulate black-brushed espresso

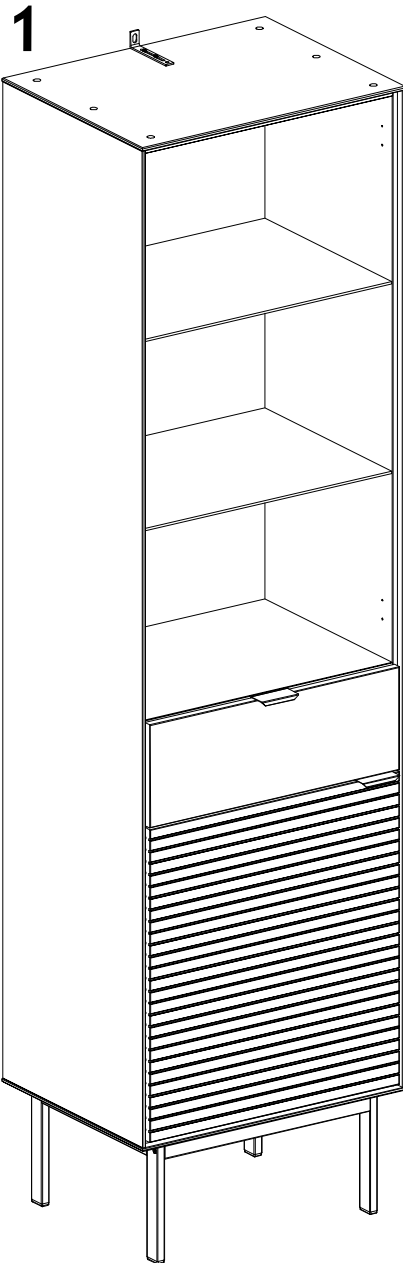

412134 left- or right-hinged door

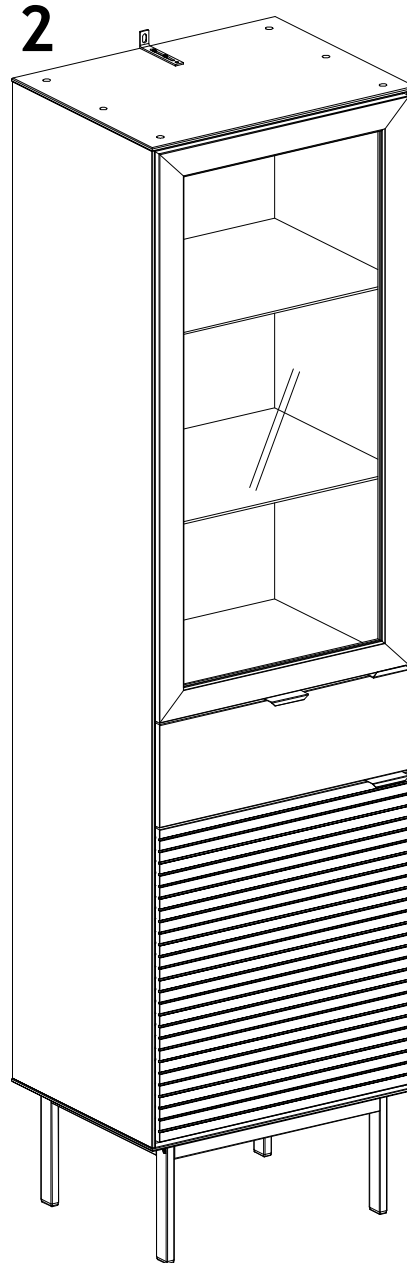

412136 left- or right-hinged doors

## Dimensions

width: 50,8 cm

depth: 41,2 cm

height: 190,0 cm



412134

21-06-2021

D: Aufbauanleitung  
 F: Instructions de montage  
 I: Istruzioni di montaggio  
 E: Instrucciones de montaje  
 GB: Assembly Instructions  
 DK: Samlevejledning

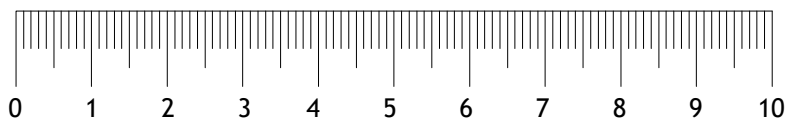
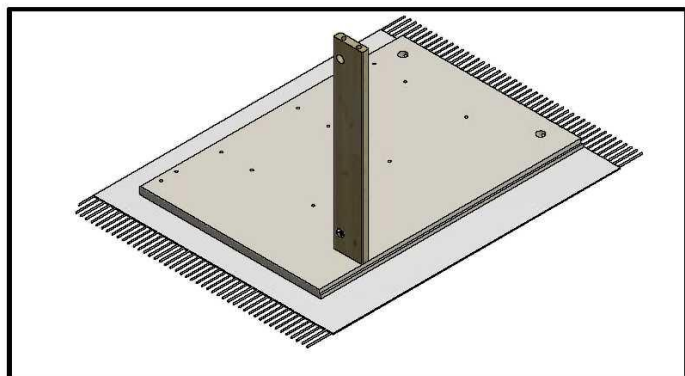
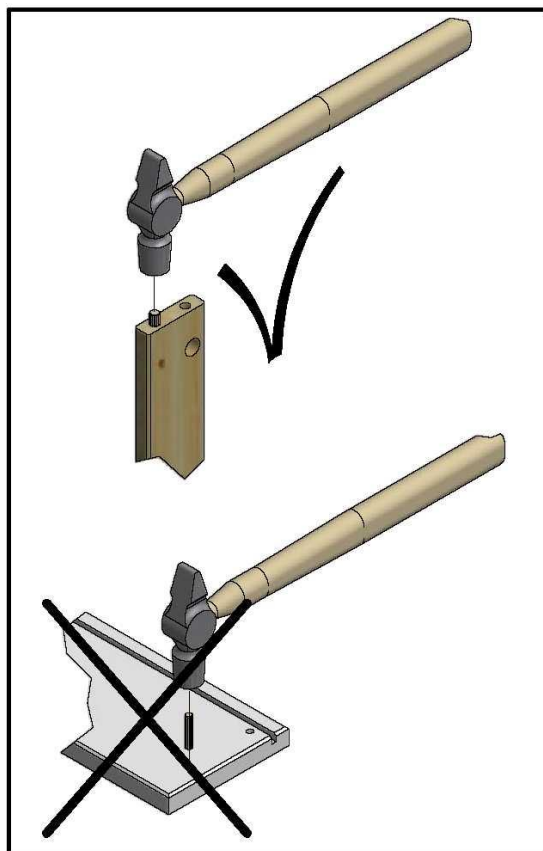
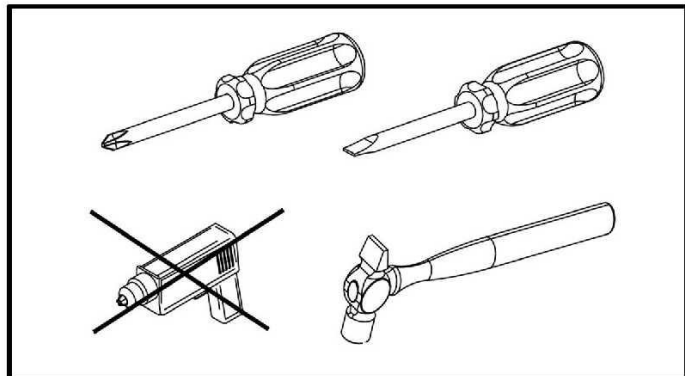
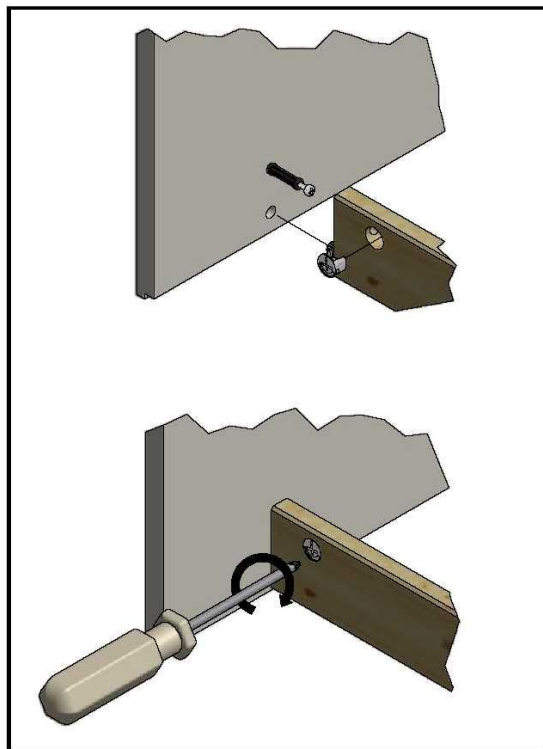
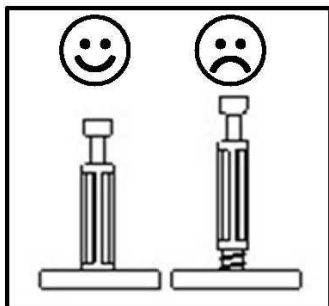

**DE:****Bewahren Sie diese Hinweise gut auf.**

Bei Nachbestellung von Neuteilen nutzen Sie bitte die Nummer auf den Deckblättern, die sich auf die korrekte Farbe bezieht, sowie die artikelnummer auf Seite 5.

Da möbel aus Naturholz ständigen Klima- und Feuchtigkeitsschwankungen ausgesetzt sind, können vereinzelt Veränderungen in der Oberfläche auftreten wie z.B. Haarrisse oder Farbveränderungen. Generell nimmt im Laufe der Zeit die Helligkeit ab und die Farbsättigung zu - das Holz dunkelt nach.

Die genannten Veränderungen sind bei einem Natur-Rohstoff wie Holz ein normaler Prozess.

**Pflegehinweise für naturbelassene/gelackte Möbel aus Naturholz:**

Die Oberfläche lässt sich am besten mit einem mässig feuchten Tuch säubern.

Achtung: Ätzende oder Lösungsmittelhaltige Reinigungsmittel oder Politur dürfen **nicht** verwendet werden:

**Pflegehinweise für Möbel aus Plattenwerkstoffen:**

Verwenden Sie zur Pflege Ihres Möbels aus Plattenwerkstoffen am besten ein weiches, nicht fuselndes Tuch oder ein Ledertuch. Wischen Sie die Oberflächen leicht feucht ab.

**FR:****Conservez bien cette notice.**

Si de nouvelles pièces sont à commander, utilisez le numéro présent en première page indiquant le bon coloris ainsi que le numéro d'article en page 5.

Comme le meuble en bois naturel est soumis aux variations permanentes du climat et de l'humidité, il se peut que quelques modifications surviennent sur la surface, comme par exemple de fines fissures ou des décolorations. En règle générale, au cours du temps, la clarté du bois diminue et son intensité de couleur augmente - le bois devient foncé. Les modifications susnommées sont un processus normal des naturelles comme le bois.

**Instructions de soin pour les meubles naturels/peints en bois naturel.**

La surface se nettoie de préférence avec un chiffon légèrement humide.

**Attention:** Les détergent agressifs ou à teneur en solvant ou les produits de polissage **ne doivent pas** être utilisés.

**Cocsignes de soin pour les meubles avec des plaques en dérivé du bois.**

Pour l'entretien de votre meuble en plaques en dérivé du bois, utilisez de préférence un chiffon doux non pelucheux ou une peau de chamois. Essuyez la surface légèrement humide.

**IT:****Conservare bene le presenti istruzioni.**

Per effettuare l'ordine di parti nuove, utilizzare il numero presente nelle prime pagine, che indica il colore corretto, e il numero dell'articolo a pagina 5.

Dato che i mobili in legno naturale sono esposti al continuo variare del clima e dell'umidità, è probabile che in superficie insorgano mutamenti quali crepe capillari o cambiamenti di colore. Generalmente con passar del tempo diminuisce la chiarezza e aumenta la saturazione del colore - il legno si scurisce.

I citati mutamenti sono un normale processo dei materiali naturali, quali appunto il legno.

**Istruzioni sulla cura dei mobili in legno naturale non trattato/verniciato.**

Il modo migliore di pulire la superficie è usare un panno moderatamente umido.

**Attenzione:** Non utilizzare lucidi per mobili oppure detergenti abrasivi o a base di solventi.

**Istruzioni sulla cura dei mobili in materiali pannellati.**

Per la cura dei mobili in materiali pannellati si consiglia di usare un panno morbido, che non lascia pali, o un panno di pelle. Passare il panno leggermente umido sulle superfici.

**ES:****Guarde estas notas en un lugar seguro.**

En caso de volver a solicitar nuevas piezas, use el número que aparece en las primeras páginas y que hace referencia al color correcto y al número de artículo de la página 5.

Puesto que los muebles de madera natural están permanentemente expuestos a las fluctuaciones meteorológicas y de humedad, en algunos casos pueden producirse cambios en la superficie (p. ej. fisuras capilares o cambios en el color). En general, con el paso del tiempo el brillo se reduce y la saturación del color aumenta, es decir, la madera se oscurece.

Los cambios mencionados son normales en materias primas naturales como la madera.

**Notas para el cuidado de muebles de madera natural no tratados ni pintados:**

Lo más adecuado para limpiar la superficie es usar un trapo ligeramente húmedo.

**Atención:** no utilizar limpiadores corrosivos ni que contengan disolventes o abrillantadores.

**Notas para el cuidado de muebles hechos con material de panel:**

Recomendamos usar un trapo suave que no suelte pelusas o una gamuza. A continuación, frote las superficies con un trapo o una gamuza ligeramente humedecidos.

**GB:****Keep these notes in a safe place.**

In case of ordering new parts, use the number on the front page, that refers to the correct colour and the item number on page 5.

Since natural wood furniture are permanently exposed to climate and humidity fluctuations, changes to the surface may occur (e.g. hair cracks or changes in color) in some cases. In general, brightness decreases and colour saturation increases in the course of time - the wood darkens.

The changes mentioned above are normal for natural raw materials such as wood.

**Care notes for untreated/painted furniture made of natural wood:**

Using a moderately damp cloth is the most suitable method for cleaning the surface.

**Attention:** Corrosive cleaners containing solvents or polish must **not** be used.

**Care notes for furniture made of panel materials:**

We recommend using a soft, lint-free cloth or chamois for conditioning your piece of furniture made of panel materials. Wipe off the surfaces with a slightly damp cloth or chamois.

**DK:****Opbevar disse noter på et sikkert sted.**

I tilfælde af genbestilling af nye dele, bruges det nummer på forsiden, der refererer til den rigtige farve og varenummeret på side 5.

Da møbler af naturtræ konstant er udsat for klimaets og luftfugtighedens forandringer kan ændringer, i nogle tilfælde, forekomme i overfladen, (f.eks hårfine revner eller ændringer i farve). Generelt, så ændre lysstyrke og farvemætning sig med tiden - træ bliver mørkere. De ændringer, der er nævnt ovenfor, er helt normale for naturmateriale som træ.

**Pleje noter for ubehandlede/malede møbler lavet af naturtræ:**

Brug en let fugtig klud til aftøring er den ubehandlede/malede møbel.





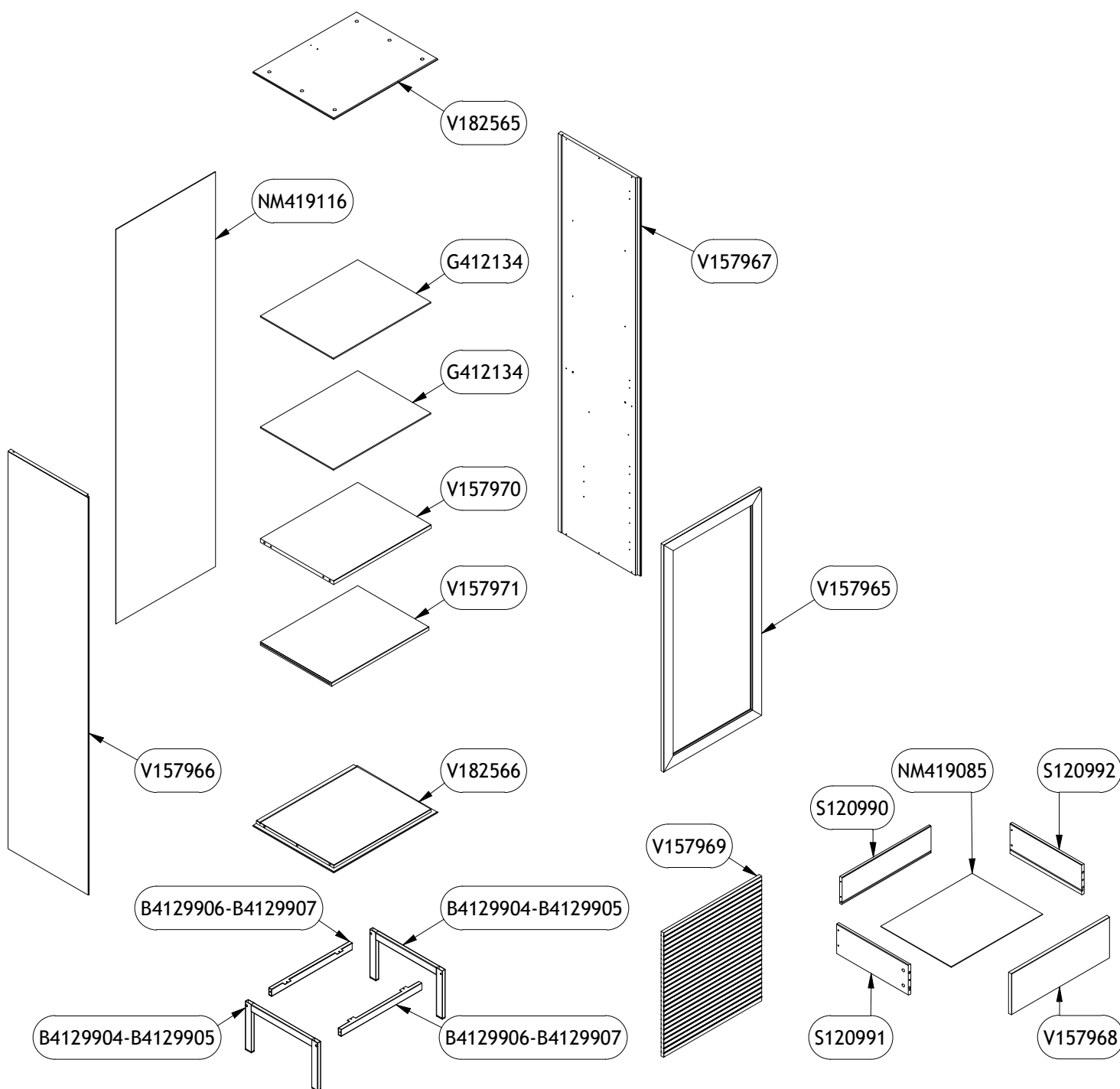

**OBS:** Ætsende rengøringsmidler, der indeholder opløsningsmidler eller polish må **ikke** anvendes.

**Pleje noter til møbler lavet af pladematerialer:**

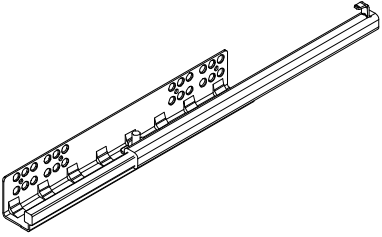
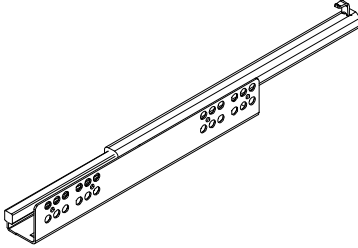
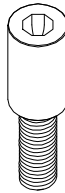
Det anbefales at møbler af plademateriale aftøres med en blød, let fugtig fnugfri klud eller et vaskeskind.

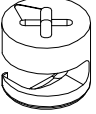
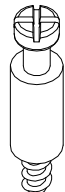
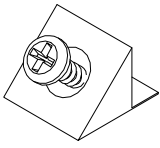
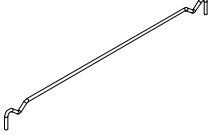
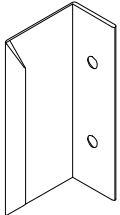
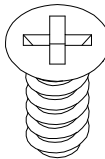
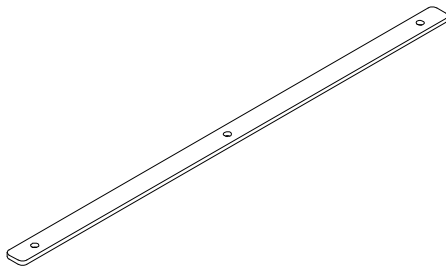
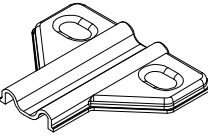
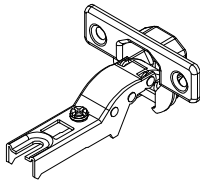
PARTS LIST					
QTY	PART NUMBER	DESCRIPTION	LÆNGDE	BREDDE	TYKKELSE
1	V182566	Bund	508	395	18,0
1	V182565	Top	508	395	18,0
1	V157971	Hylde	476	349	15,0
1	V157970	mellembund	476	359	15,0
1	V157969	Låge H/V	480	528	15,0
1	V157968	Skuffefront	480	174	15,0
1	V157967	Side H	1683	394	15,0
1	V157966	Side V	1683	394	15,0
1	V157965	Låge med glas	961	480	15,0
1	S120992	Skuffeside H	350	128	15,0
1	S120991	Skuffeside V	350	128	12,0
1	S120990	BAGSKUFFE	436	115	12,0
1	NM419116	Bagklædning	487	1670	2,5
1	NM419085	SKUFFEBUND	447	345	2,5
2	G412134	Glashylde	476	357	4,0

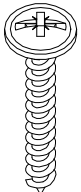
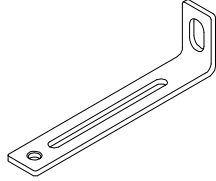
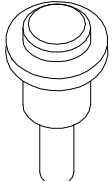
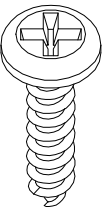
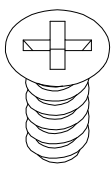
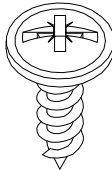
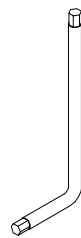

B14962 x 1		B14963 x 1		BA14742 x 4 Ø8x29	BA10400 x 6 ø6x30 mm
					
BA10597 x 20 ø12x10,2 mm	BA10601 x 20 ø5/8x24 mm	BA10833 x 10 15x15x10 mm	BA10826 x 2 Ø2,75 x 224	BA14720 x 3 70x20x1,5	BA14743/623 x 6 ø4,2x9,5 mm
					
B4129903099 x 2 480x20x4		BA14697 x 4	BA14694 x 4 ø26 cc38	BA103480 x 4 ø16 mm	BA10170 x 4 ø4,0x35 mm
					
BA14715 x 1 101x16x28,5x2,5	BA14628 x 8	BA10112 x 6 ø3,5x16 mm	BA14623/743 x 20 ø4,2x9,5 mm	BA10167 x 6 ø4,0x15 mm	BA10680 x 1 4 mm
					
					

1

BA10601 x 16 B14962 x 1 B14963 x 1 BA14623/743 x 4 BA14628 x 8 BA10826 x 2  
ø5/8x24 mm ø4,2x9,5 mm Ø2,75 x 224

412134

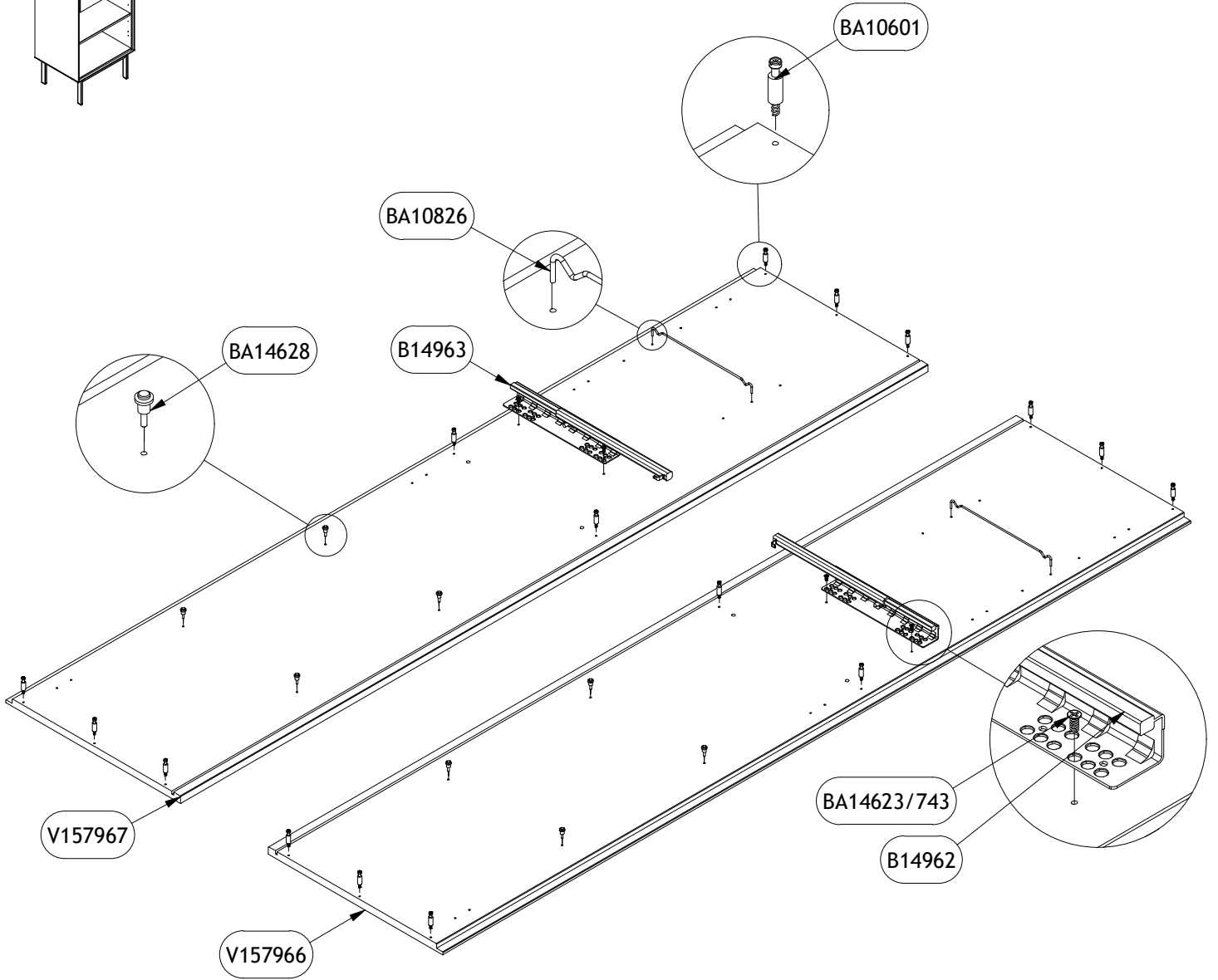
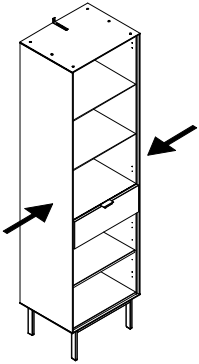
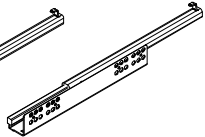
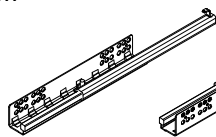
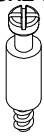

2

BA10400 x 4  
 ø6x30 mm

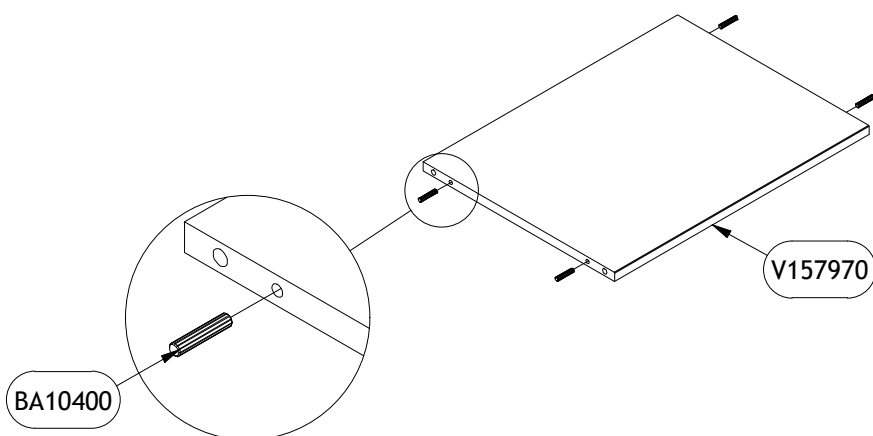
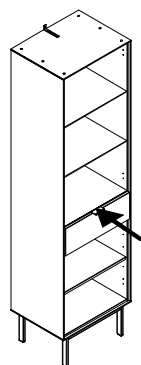
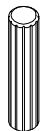

3

BA10597 x 8  
 ø12x10,2 mm

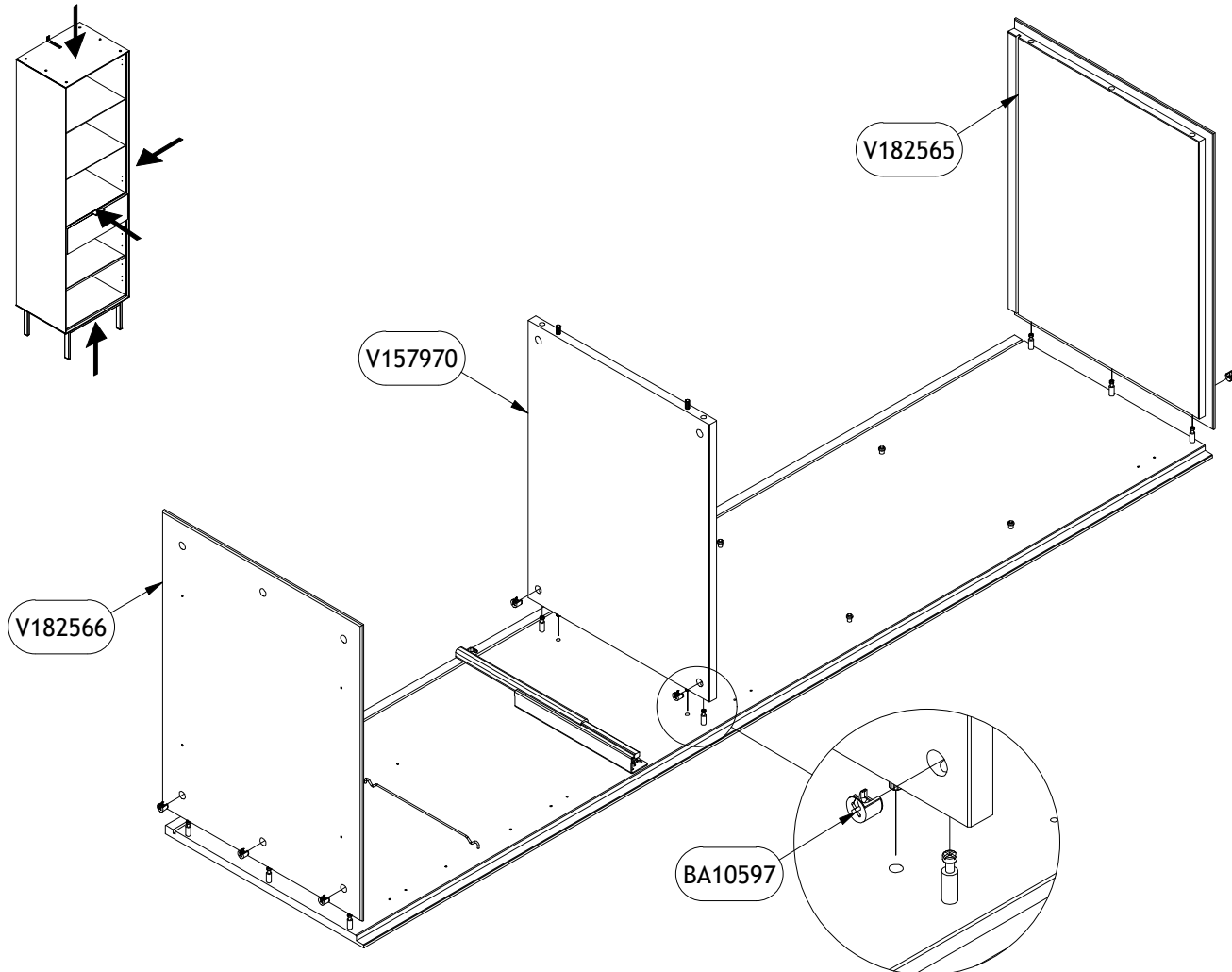
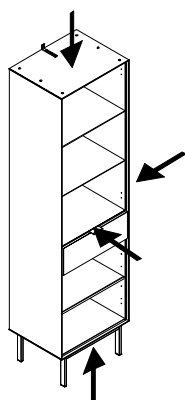



4

BA10597 x 8  
ø12x10,2 mm

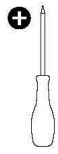

412134

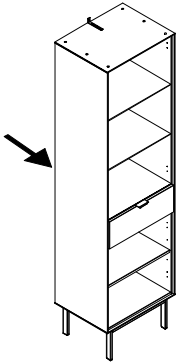

NM419116

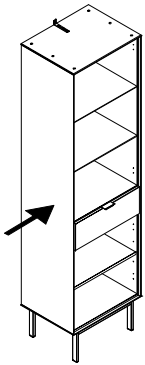
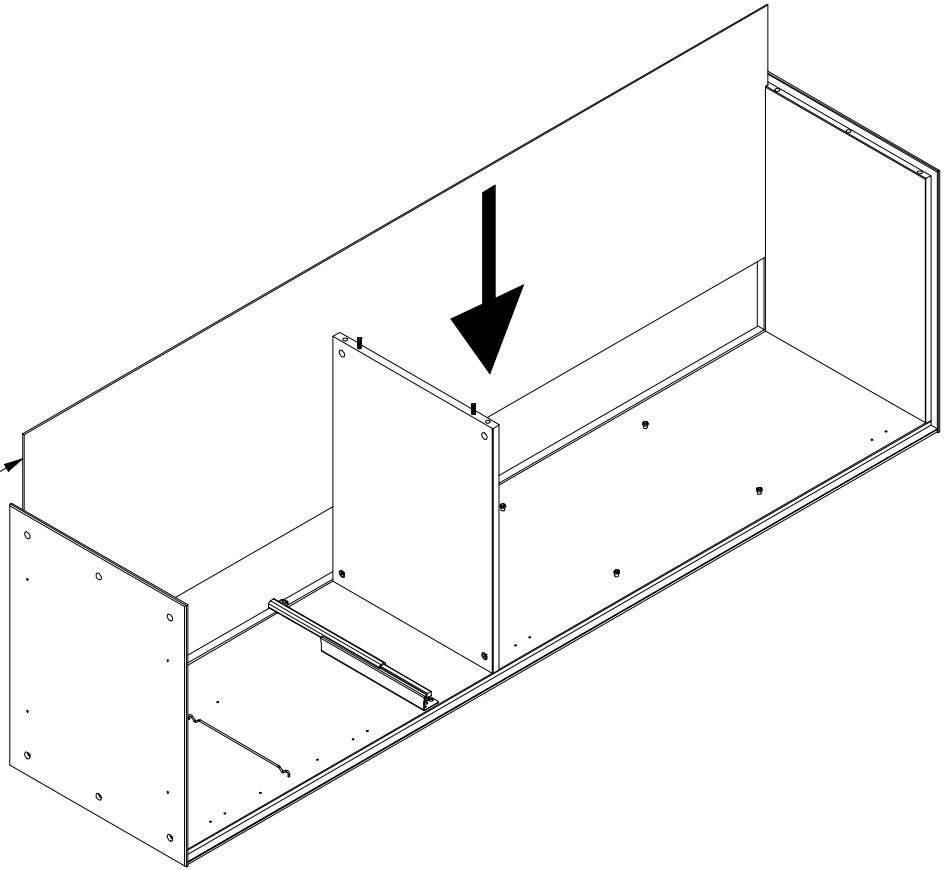

V157966

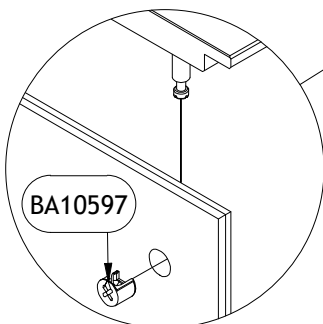
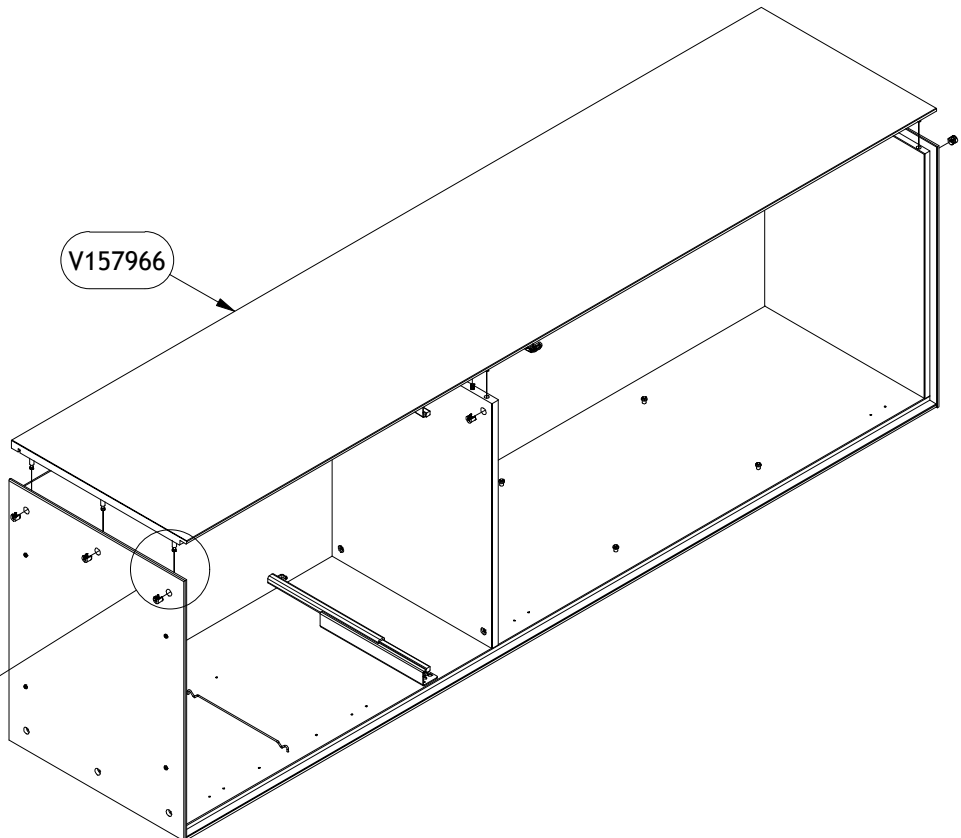

BA10597

# 5

BA14742 x 4 BA10680 BA10112 x 4

Ø8x29

4 mm

ø3,5x16 mm

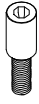

# 412134

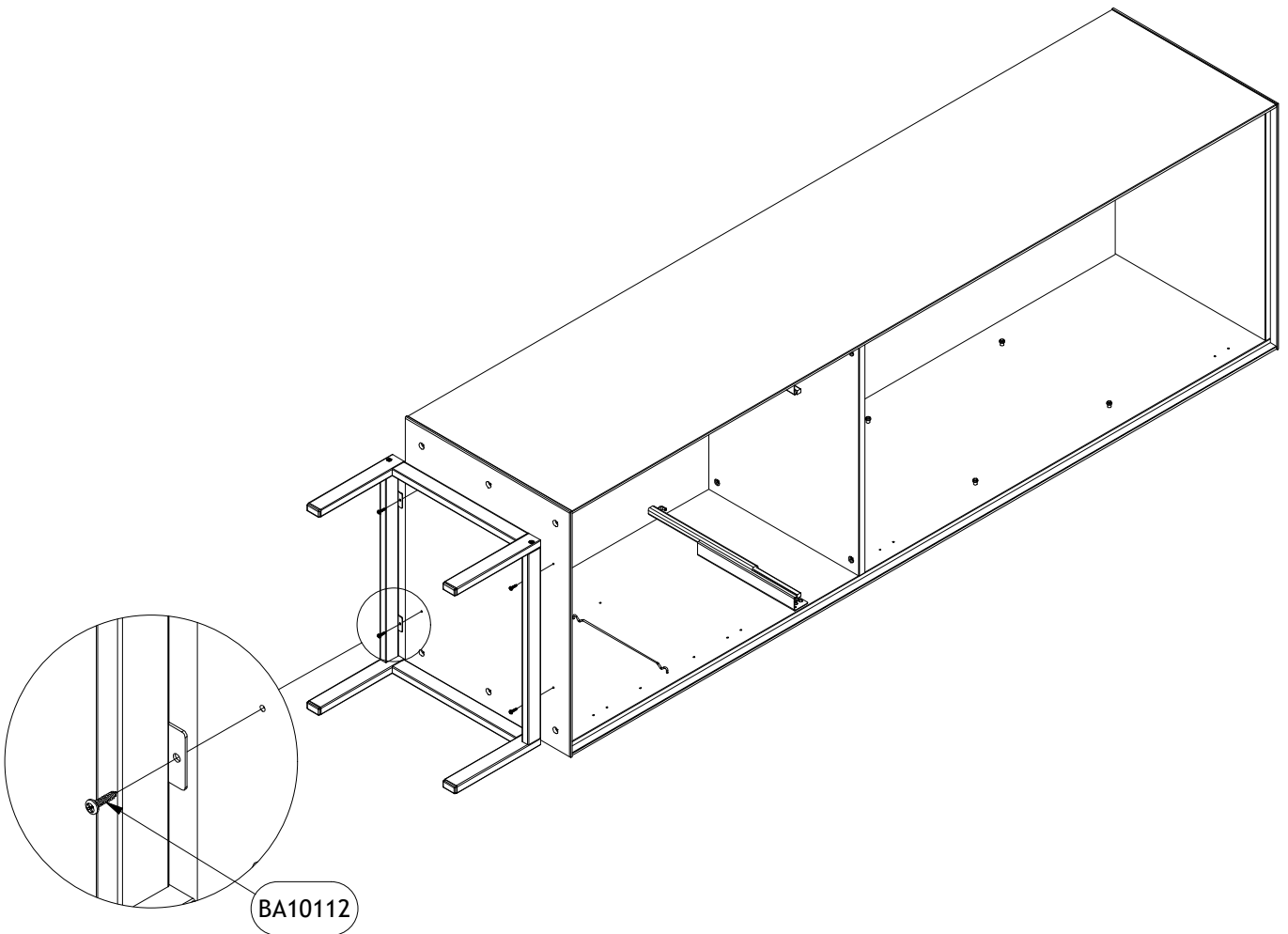
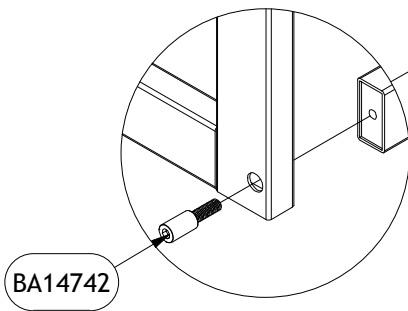
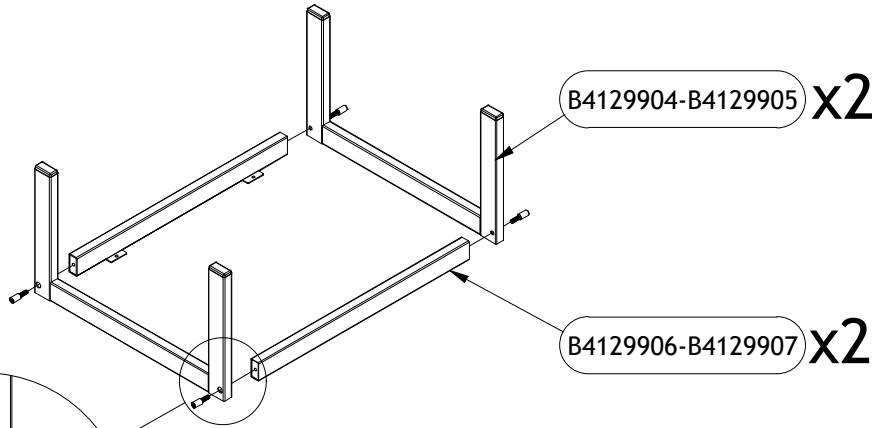
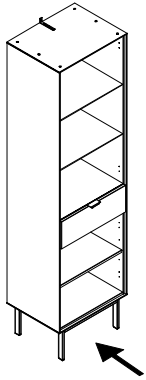

6

BA10833 x 10  
15x15x10 mm

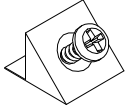

412134

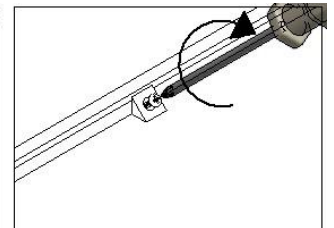
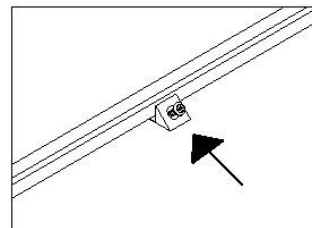
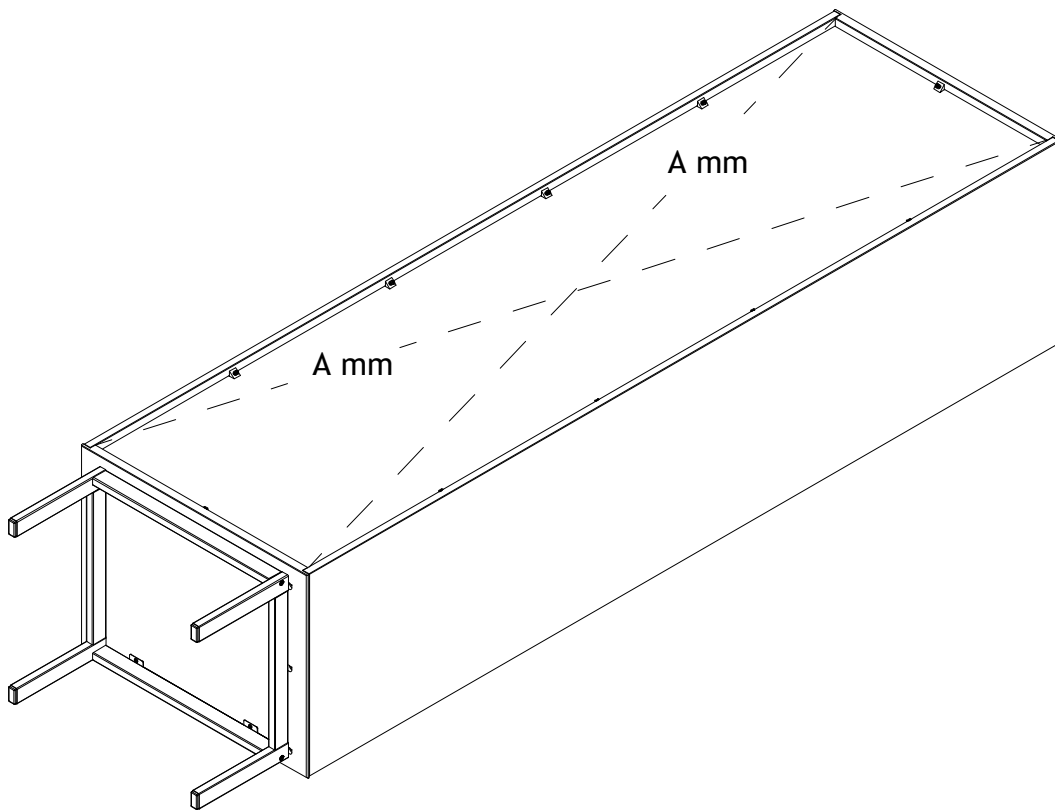
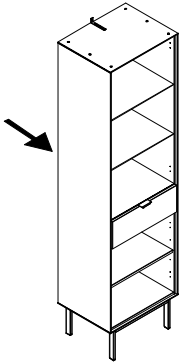

# 7

BA14715 x 1 BA10112 x 2  
101x16x28,5 ø3,5x16 mm



# 412134

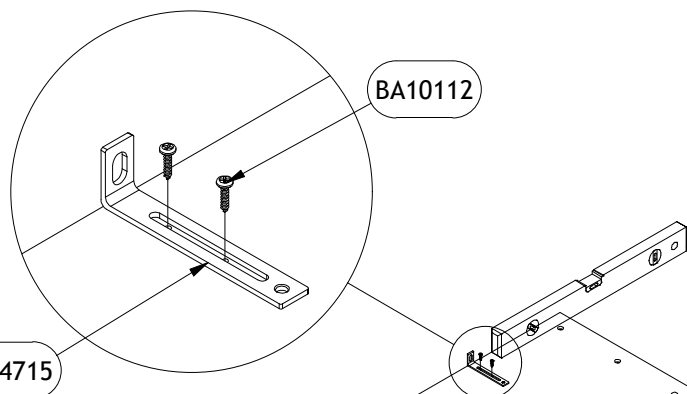

BA14715

BA10112

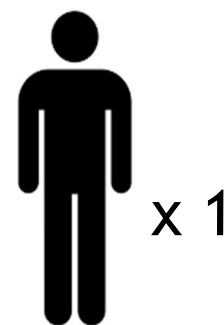
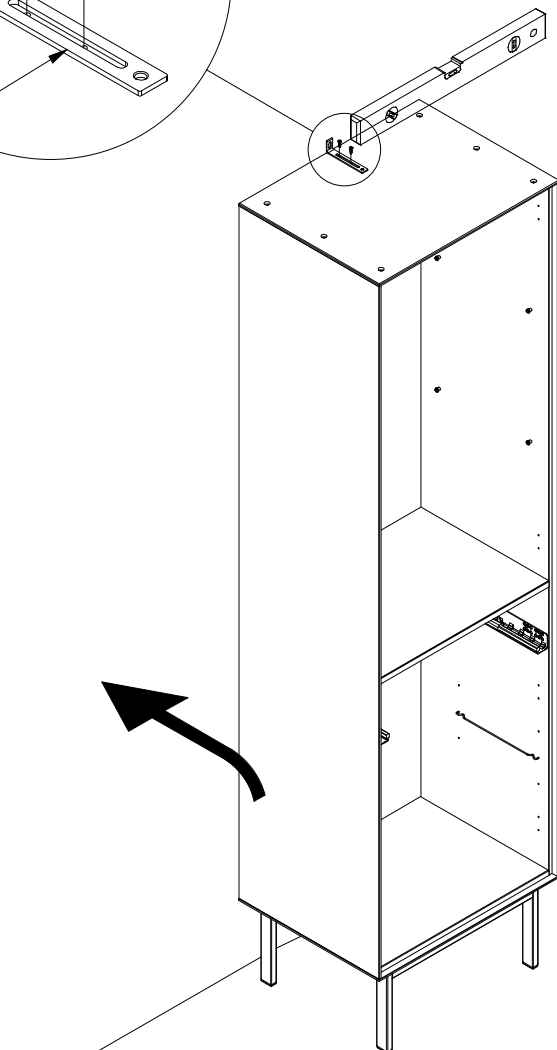

8

BA10400 x 2  
ø6x30 mm

BA10601 x 4  
ø5/8x24 mm

BA10597 x 4  
ø12x10,2 mm



412134

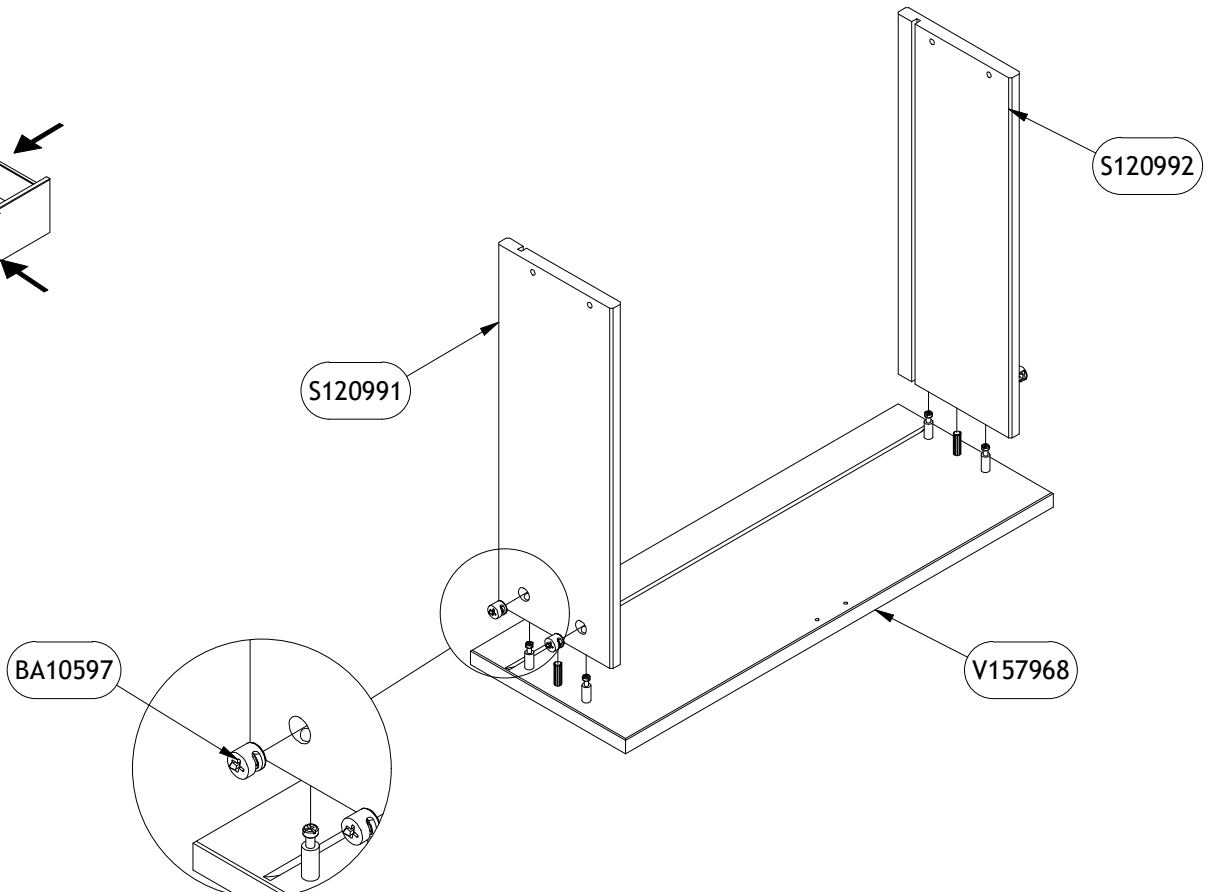
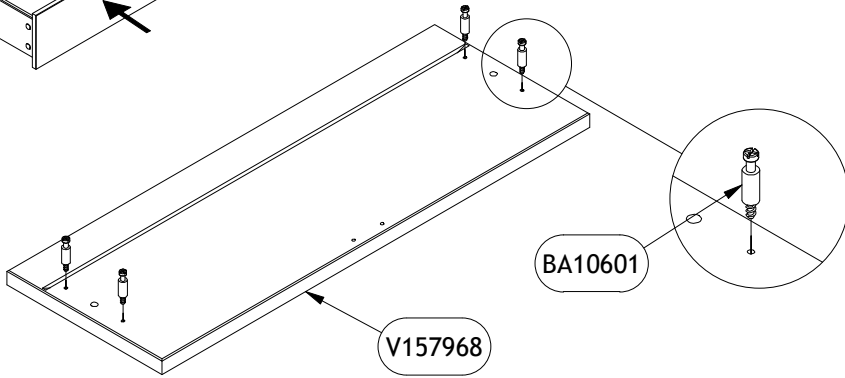
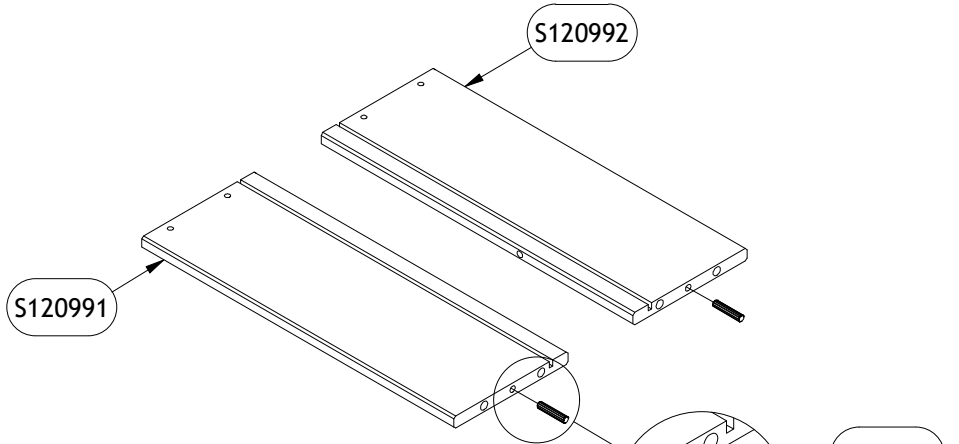
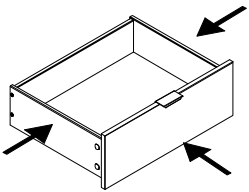
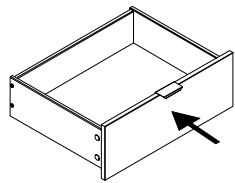
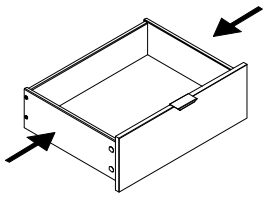

9

412134

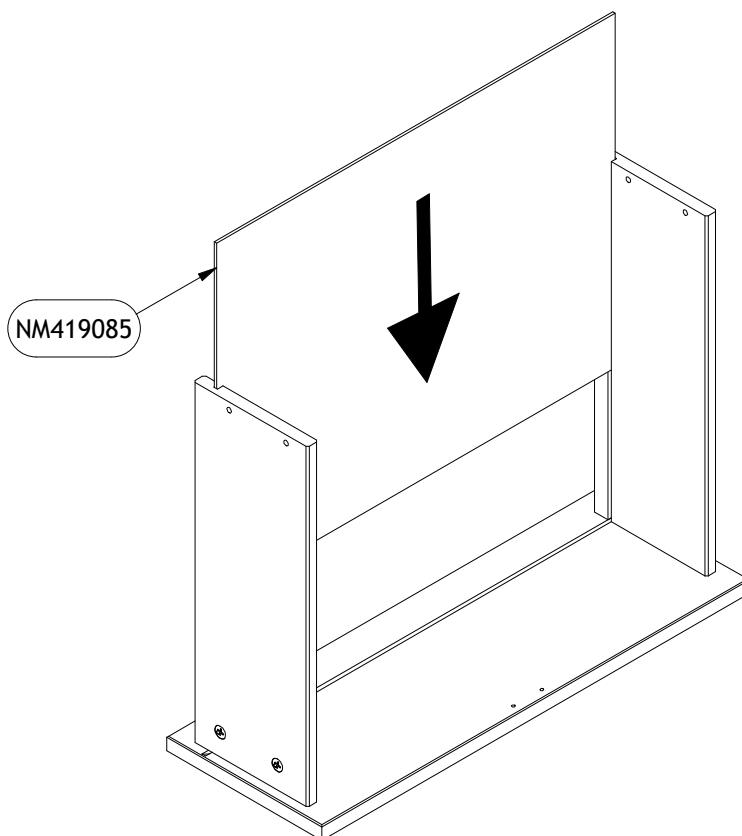
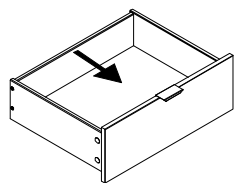

10

BA10170 x 4  
ø4,0x35 mm

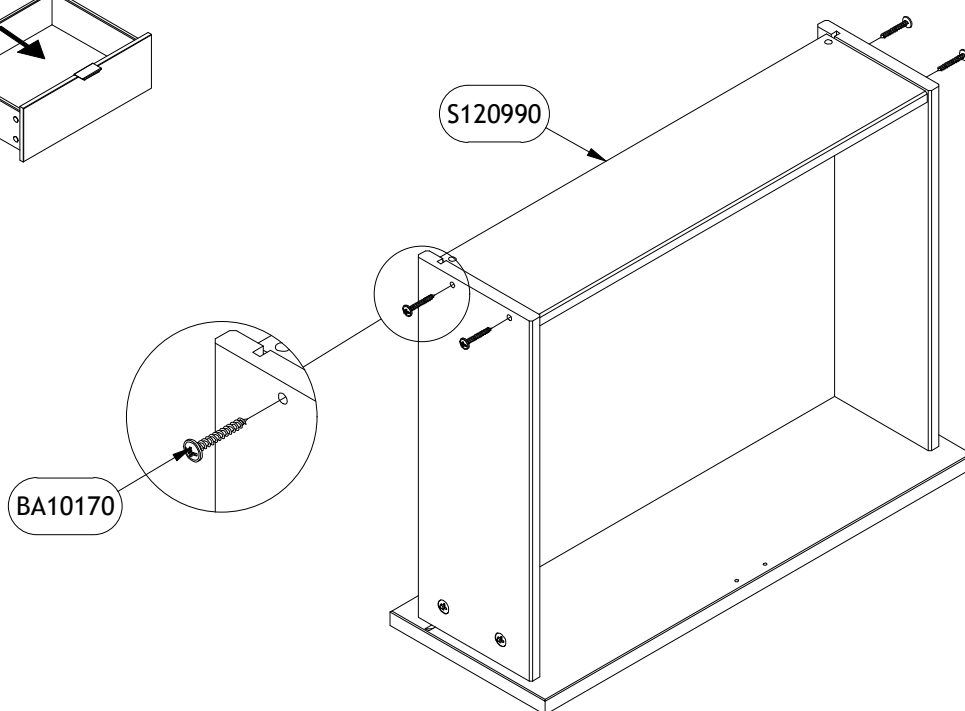
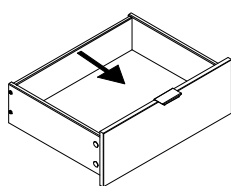

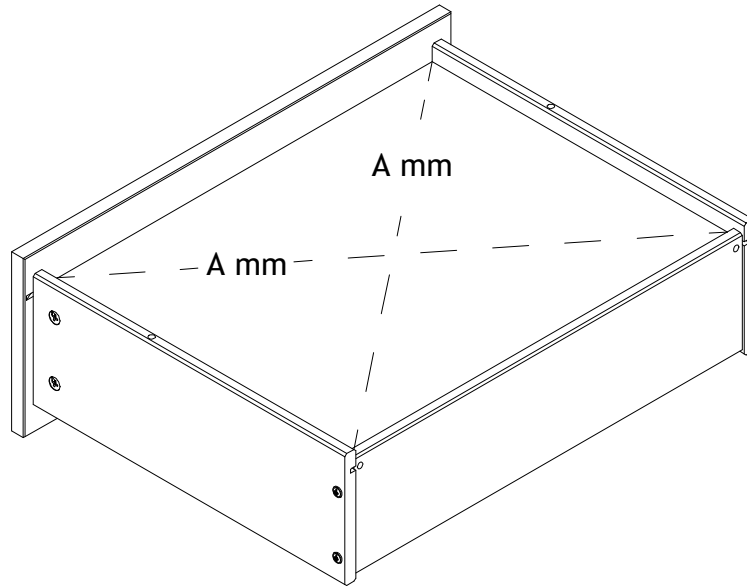
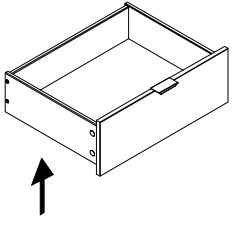

# 12

BA14720 x 1 BA14743/623 x 2 BA103480 x 4  
70x20x1,5  $\varnothing 4,2 \times 9,5$  mm  $\varnothing 16$  mm

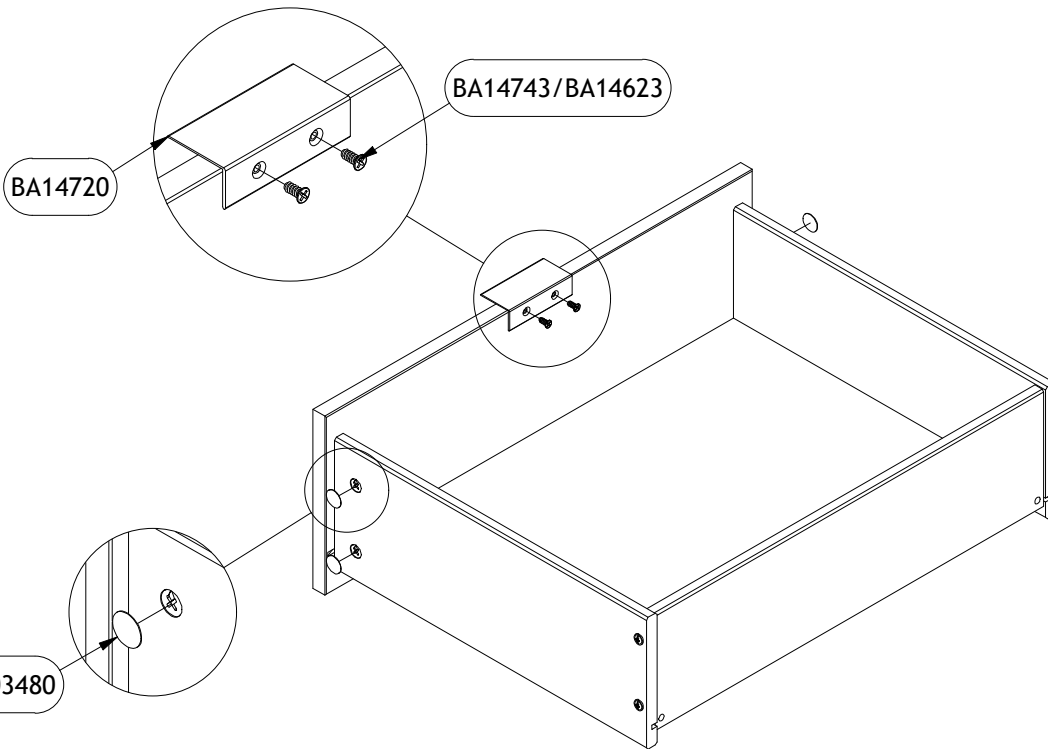
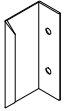

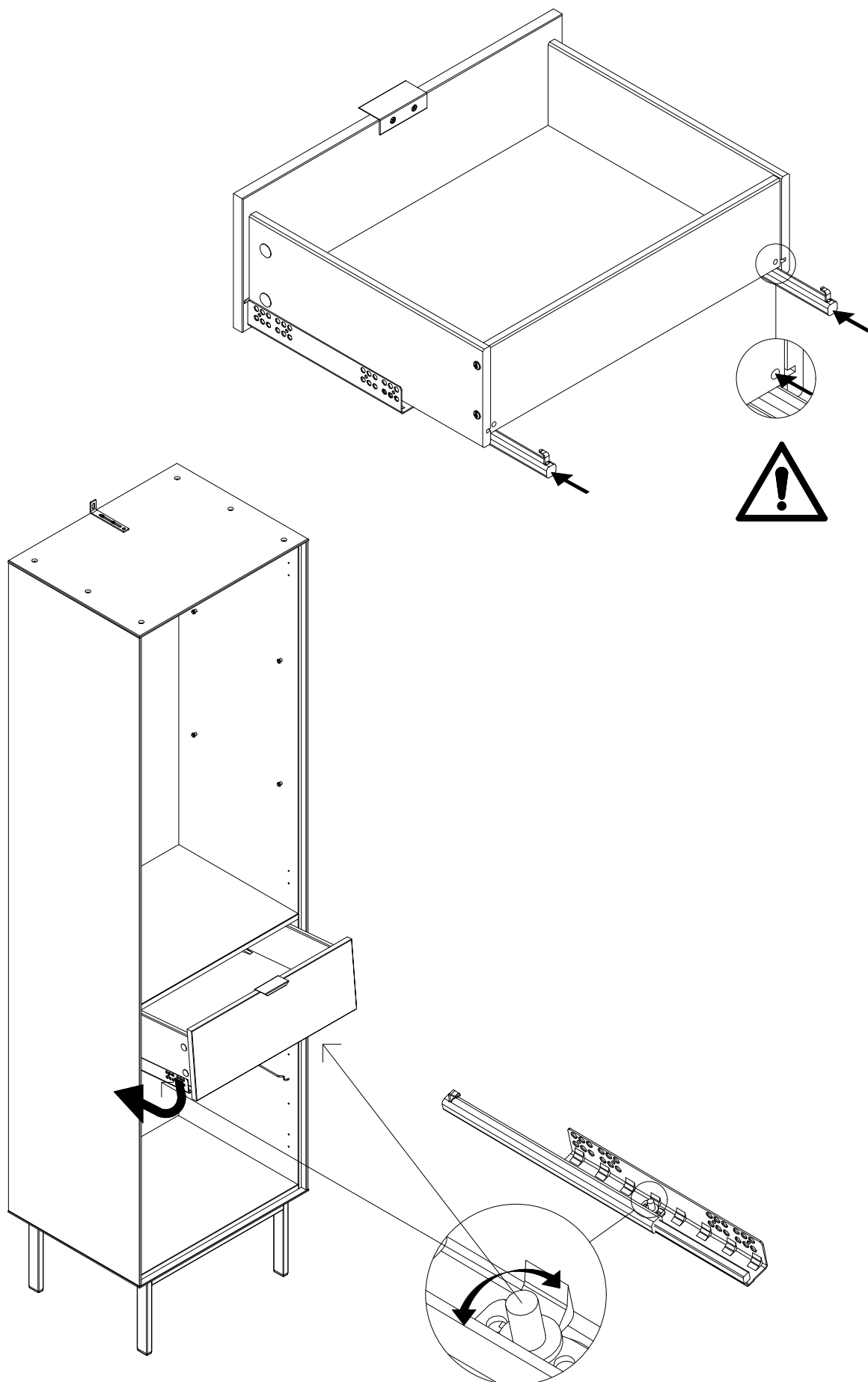



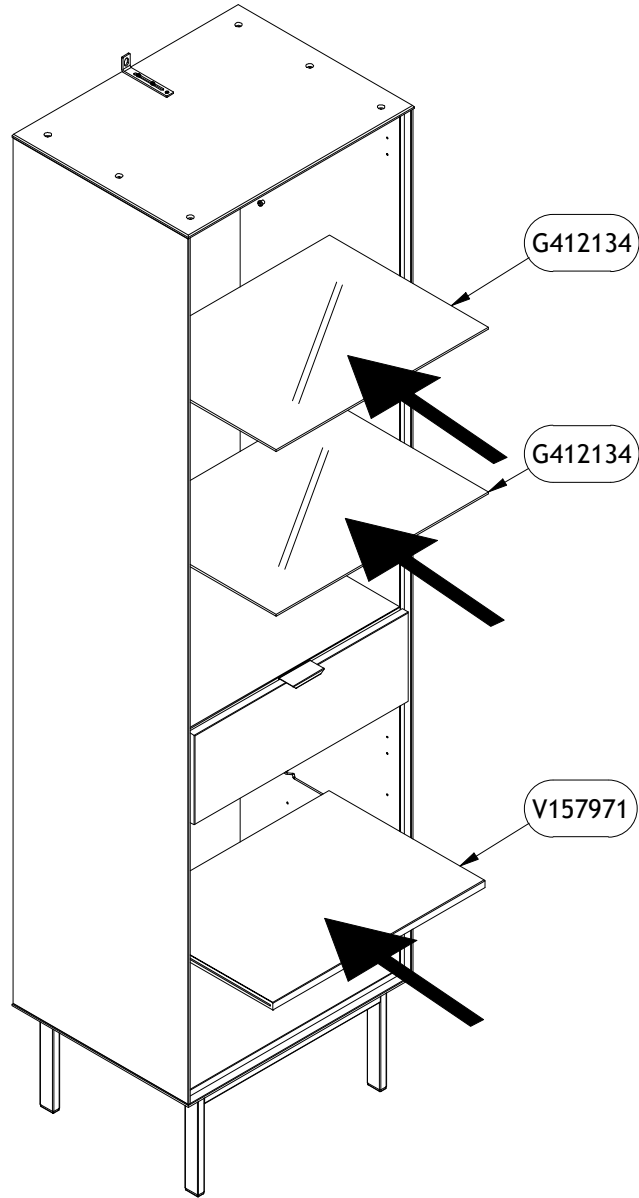

# 15

B4129903099 x 2  
480x20x4

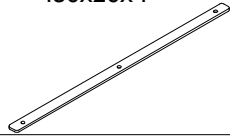

BA10167 x 6  
ø4,0x15 mm



BA14694 x 2  
ø26 cc38

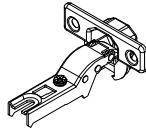

BA14623/743 x 4  
ø4,2x9,5 mm



# 412134

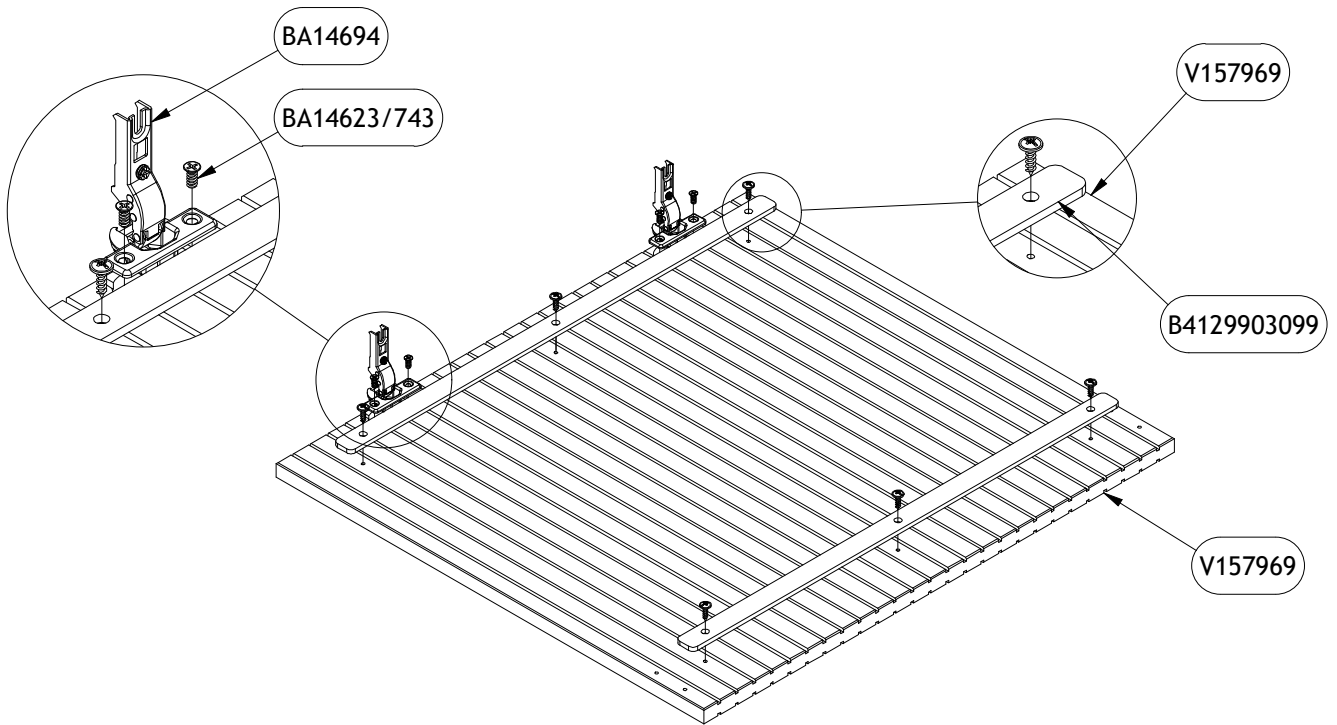
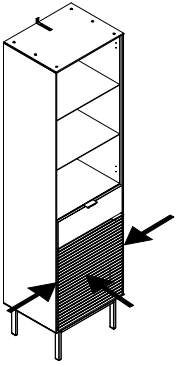

# 16

BA14697 x 2 BA14623/743 x 4  
ø4,2x9,5 mm

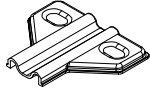

# 412134



## 1 left

## 1 right

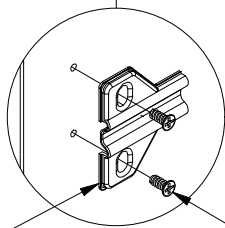
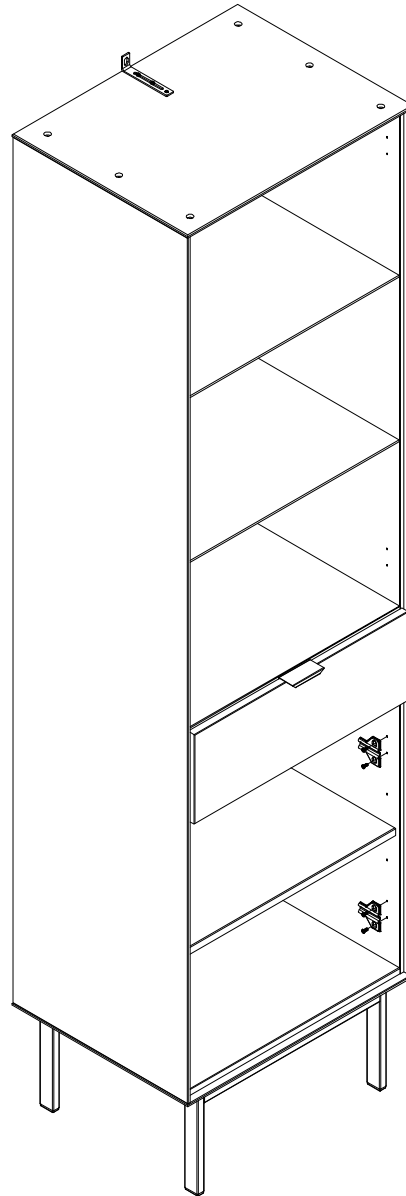
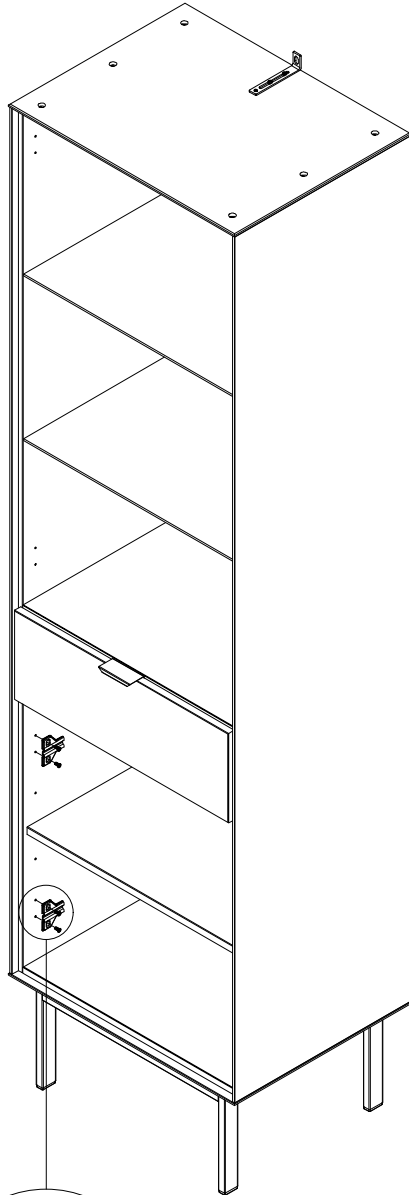

BA328306

BA14623/743

# 17

BA14720 x 1 BA14743/623 x 2  
70x20x1,5 ø4,2x9,5 mm

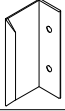

# 412134

## 1 left

## 1 right

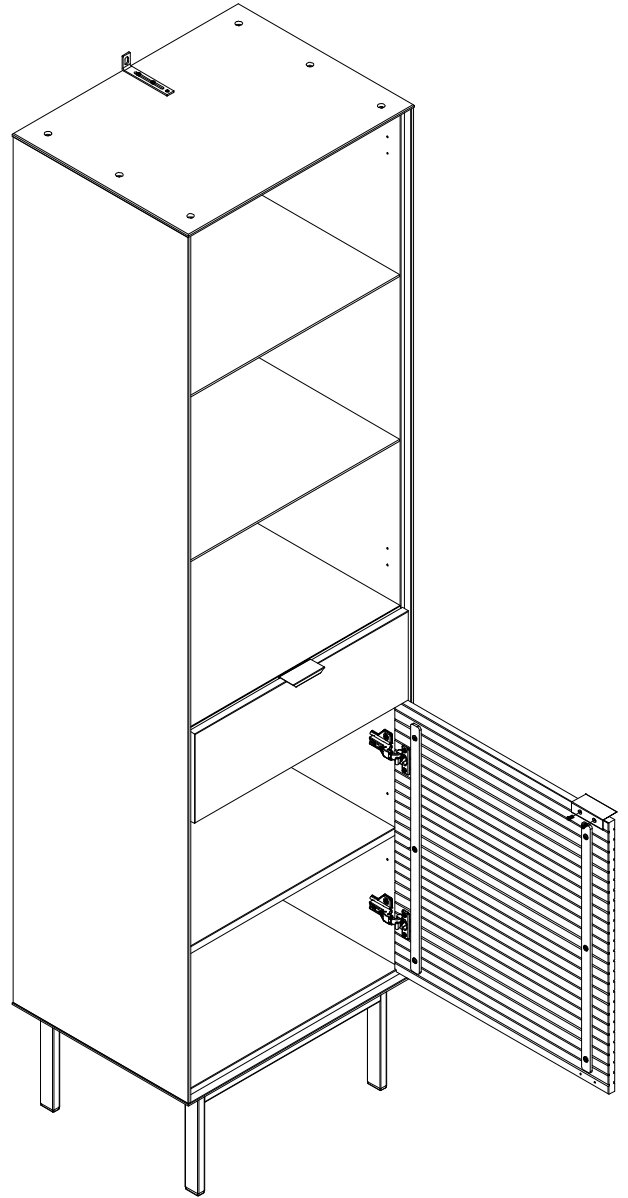
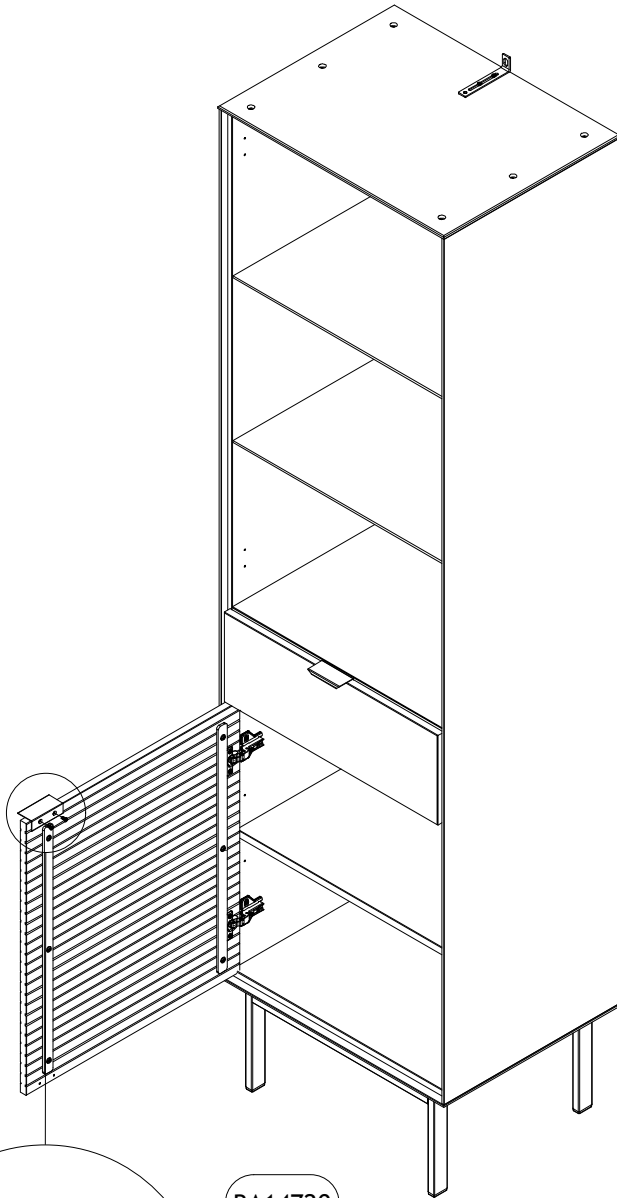

BA14720

BA14743/623

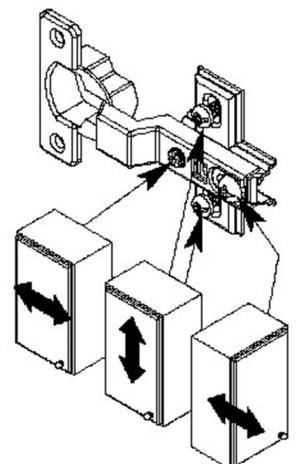

# 18

BA14694 x 2  
ø26 cc38

BA14623/743 x 4  
ø4,2x9,5 mm

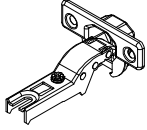
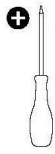

# 412134

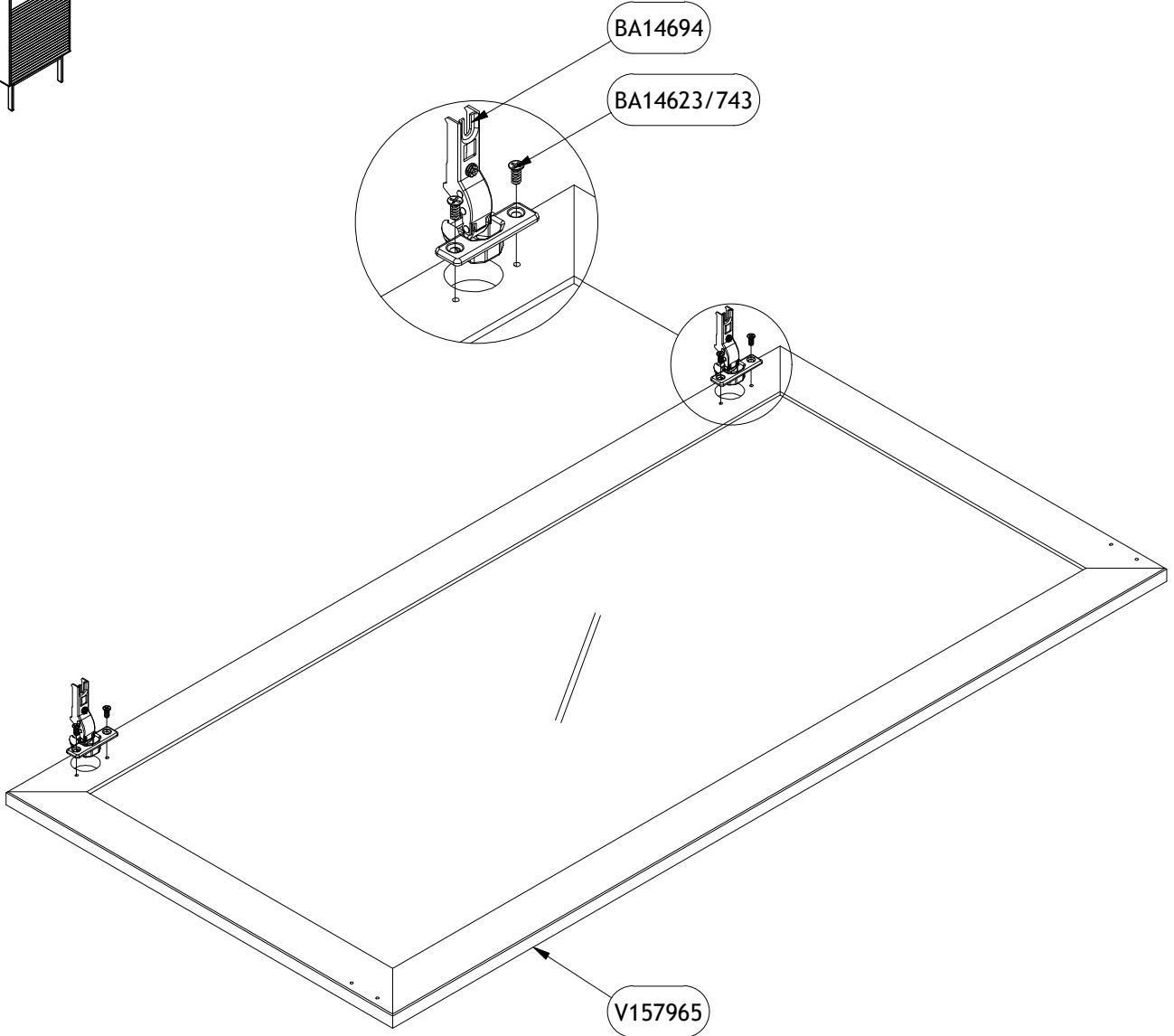
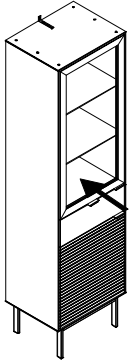

19

BA14697 x 2 BA14623/743 x 4  
ø4,2x9,5 mm

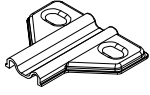

412134

2 left



2 right

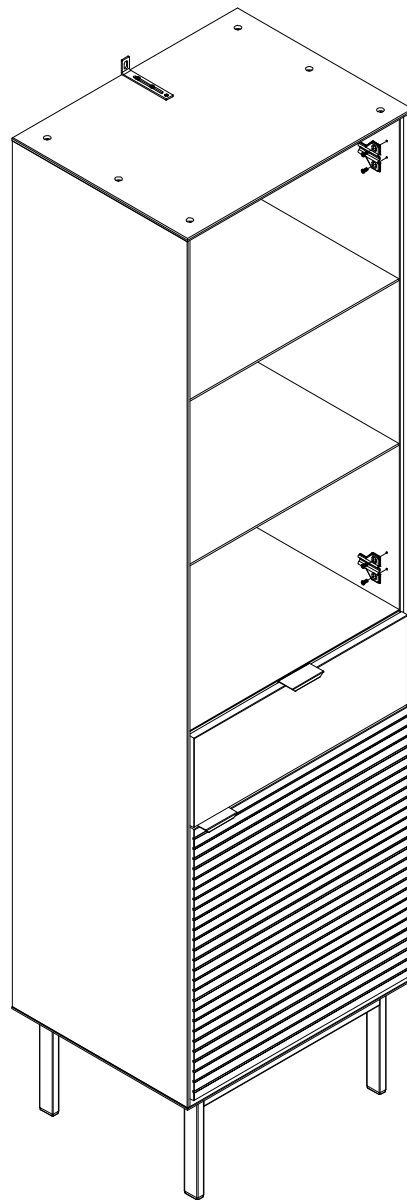
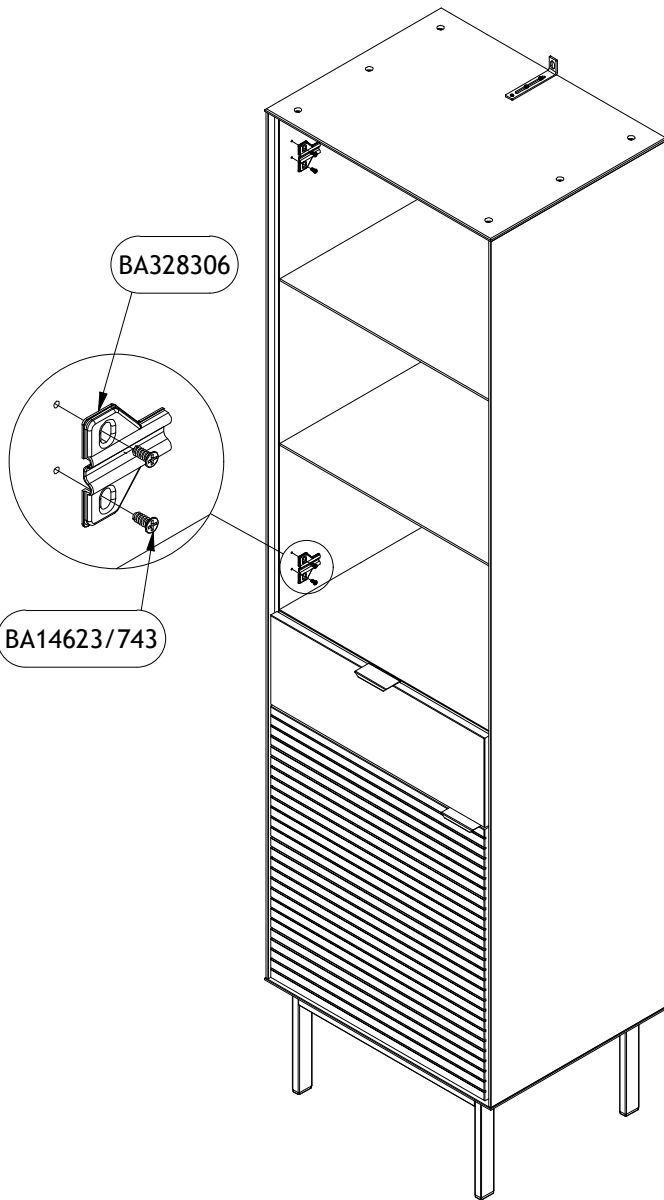

# 20

BA14720 x 1 BA14743/623 x 2  
70x20x1,5 ø4,2x9,5 mm

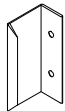

# 412134

## 2 left

## 2 right

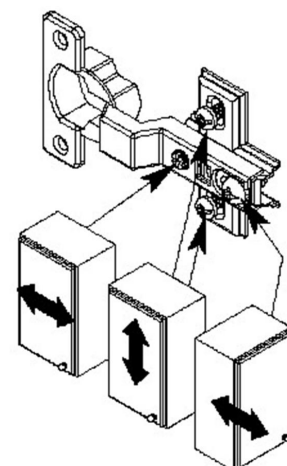
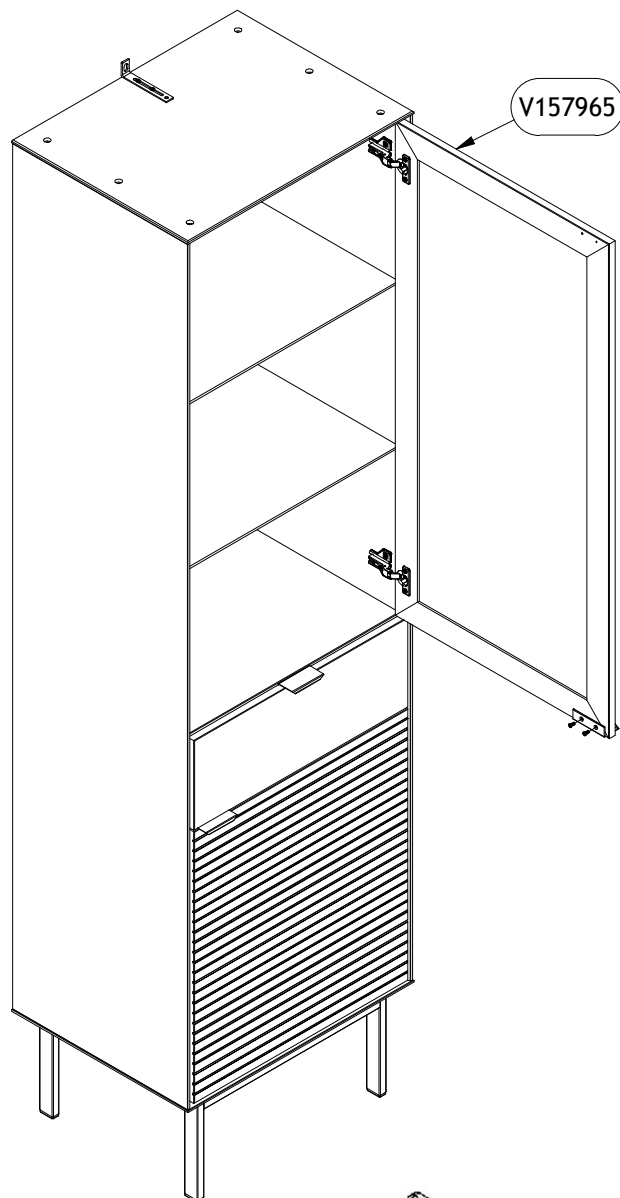
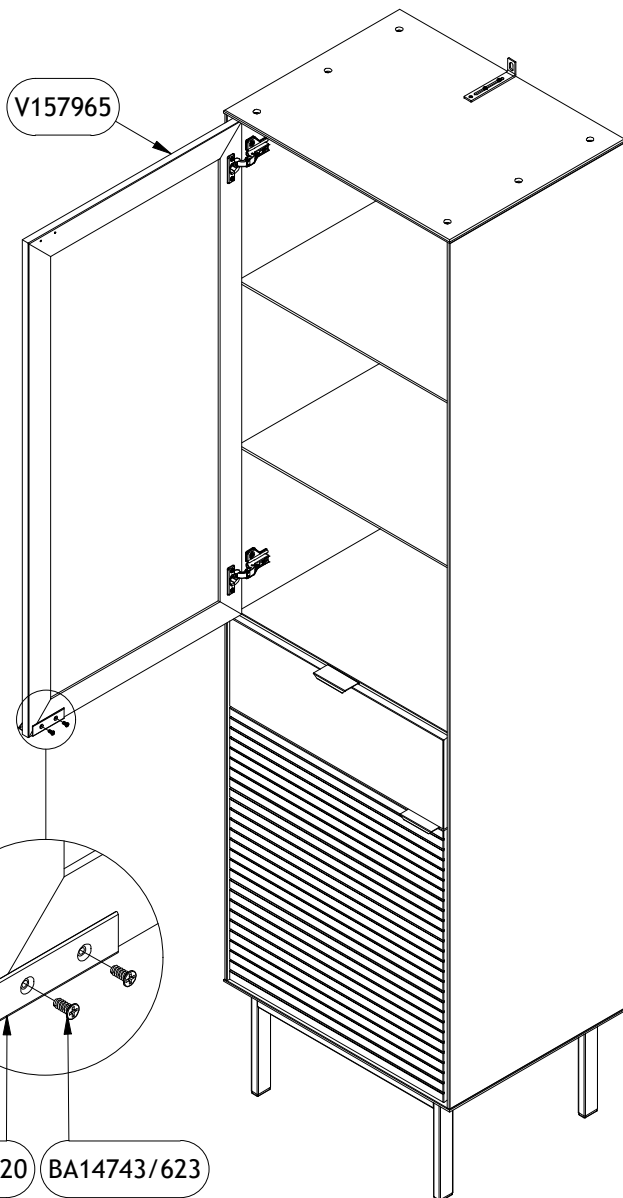

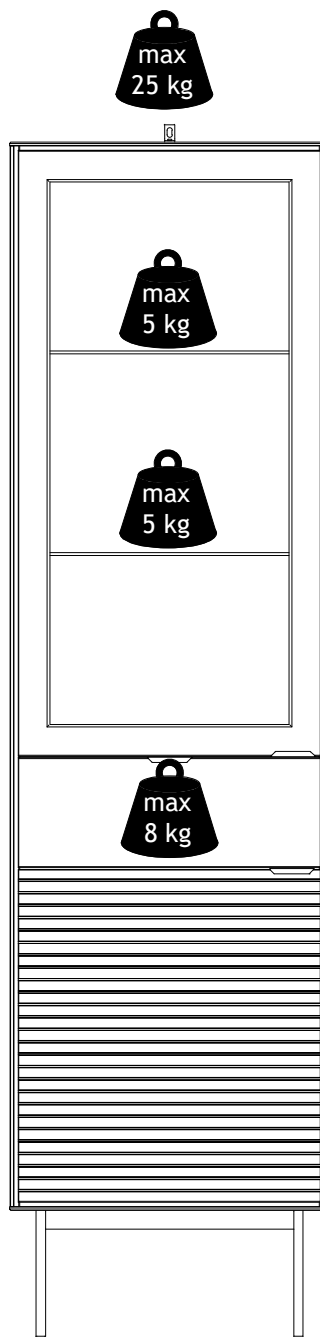
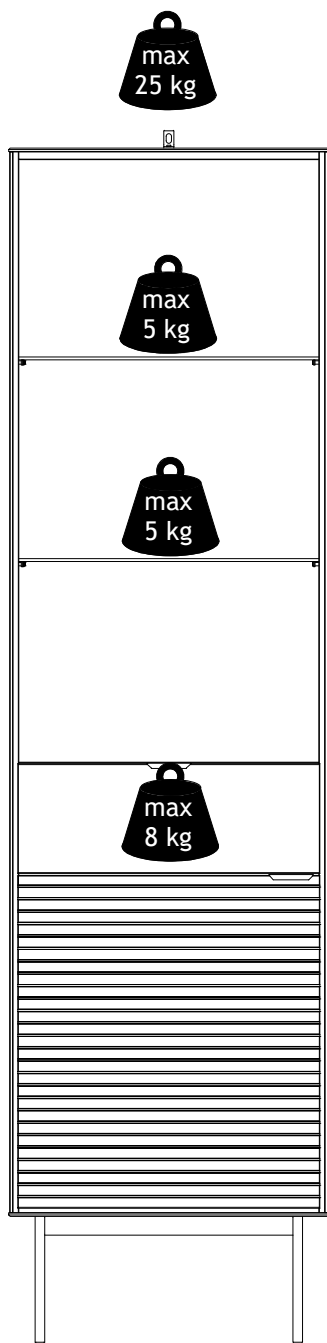



# Wall Mounting & Fixings

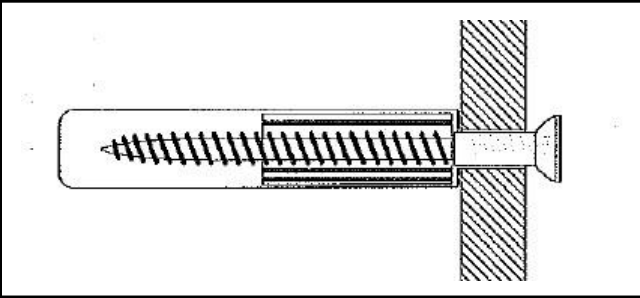

### Important:

When drilling into walls always check that there are no hidden wires or pipes ect. Make sure that the screws and wall plugs being used are suitable for supporting your unit. Consult a qualified tradesperson if you are unsure.

### HINTS:

- 1) General Rule  Always use a larger screw and a wall plug if you are not sure.
- 2) Ensure you use the recommended drill bit to match the wall plug and hole size.
- 3) Ensure you drill the hole horizontally, do not force the drill or enlarge the hole.
- 4) Take extra care when drilling high walls, ceilings and ceramic tiles. Ensure the plug is fitting below the ceramic tile to avoid splitting or cracking.
- 5) Ensure wall plugs are well fitted and are a tight fit in the drilled hole.

## Types of walls

You can use one of the following types of wall plug if your walls are made of brick, breeze block, concrete, stone, wood or plaster board.

### No. 1 "Standard" Wall Plug General Wall Materials.

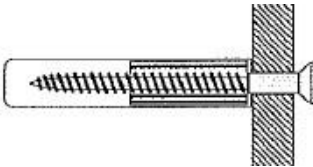

These come in various sizes and are made from plastic or sometimes wood fiber.

### No. 2 "General Purpose" Wall Plug Aerated/Breeze Block.

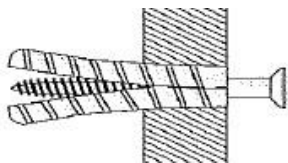

General aerated blocks should not be used to support heavy loads, use a specialist fitting in this case. For light loads, a General Purpose Plug can be used.

### No. 3 "Shield Anchor" Wall Plug Heavy loads.

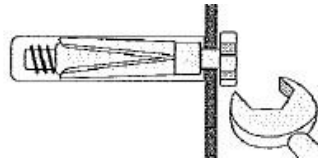

For use with heavier loads such as TV & HiFi Speakers and Satellite Dishes etc.

### No. 4 "Cavity Fixing" Wall Plug.

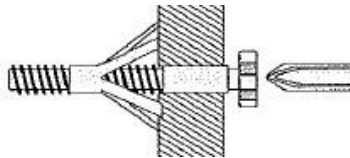

For use with plaster board partitions or hollow wooden doors.

### No. 5 "Cavity Fixing Heavy Duty" Wall Plug.

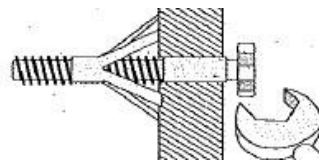

For use when fitting or supporting heavy loads such as shelving, wall cabinets, coat racks.

### No. 6 "Hammer Fixing" Wall plug.

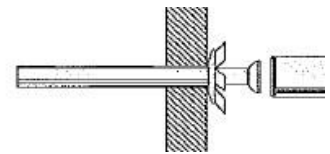

For use with walls stuck with plaster board. The hammer fixing allows it to be fixed to the wall rather than the plaster board. Always check the fixing is secure to the retaining wall.

## Care & Maintenance



Always check the fitting and location to ensure your safety in and around the home.

## Care & Maintenance



From time to time check the fitting to ensure the wall plugs or screws do not become loose.