



(D) Videounterstützte Montageanleitung

(TR) Video destekli kurulum talimatları

(RU) инструкция по монтажу с помощью видеосигнала

(RO) Instrucțiuni de instalare acceptate video

(GB) Video-assisted assembly instructions

(IT) Istruzioni di montaggio video-assistite

(CZ) Instalační pokyny podporované videem

(PL) Instrukcje montażu wspomagane sygnałem wizyjnym

(FR) Instructions de montage assistées par vidéo

(NL) Video-ondersteunde montage-instructies

(HU) Video-támogatott telepítési utasítások

(SK) Inštalčné pokyny podporované videom

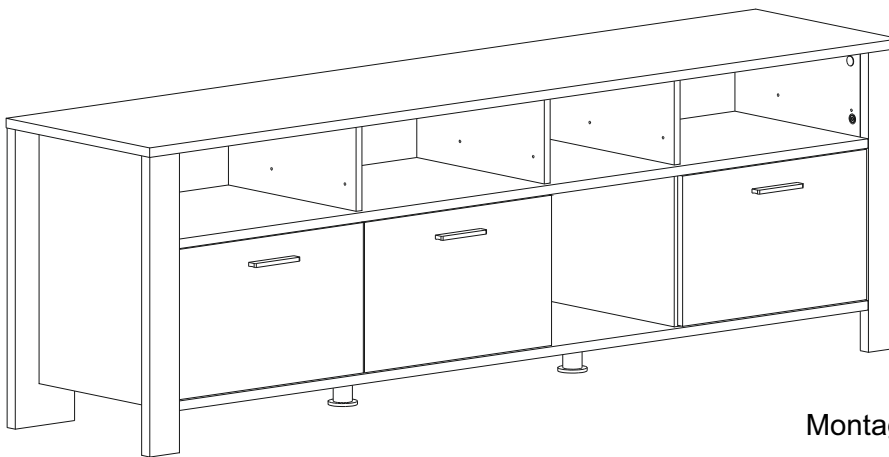
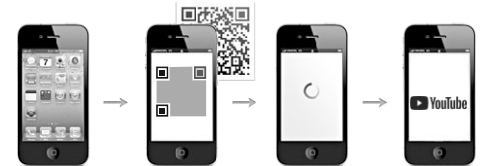

Montageanleitungs.-Nr.:

MA1-00149 Lowboard

REPC-Nr.:

Service • Assistenza • Dienstverlening • Serwis
Servis • Szerviz • Сервисная служба

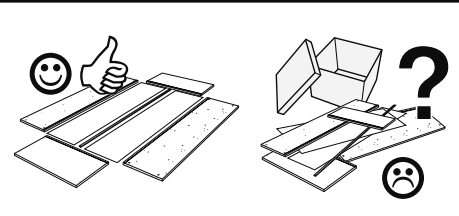
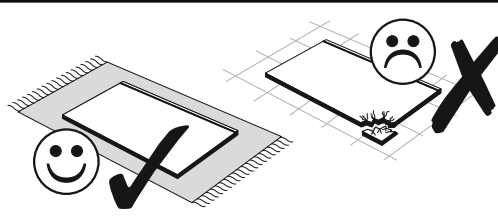
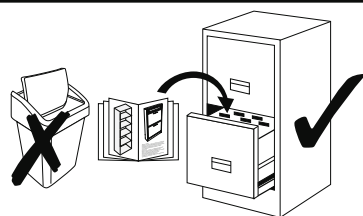
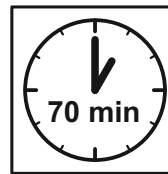
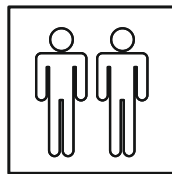
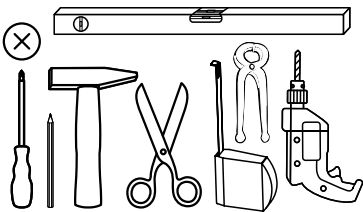

SCAN ME

Das Ersatzteil-Anforderungsformular finden Sie auf
The replacement parts requisition form you find on
<https://www.maeusbacher.de/ersatzteile/>

BT1-00393 Colli 1/2

B02-10 16x ø15x12mm	B02-20 28x	B02-103 18x 8x30
B01-30 58x 3x16	B01-10 10x 6,3x50	B01-175 4x 4,5x60
B01-329 6x M4x22	B02-08 12x ø15x10mm	B01-70 6x 3x30
B01-199 12x 6,3x9,5	B01-33 6x 4,0x17	B08-80 1x

BT1-00394 Colli 1/2

B05-02 6x ø20mm	B05-02 K1002 6x ø20mm
B05-130 2x Leim	B06-440 3x
B05-01 4x ø14mm	B05-01 K1002 12x ø14mm



▶ SCAN ME

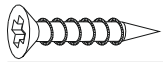

L = 20 mm

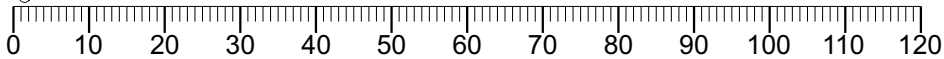

Colli 2/2

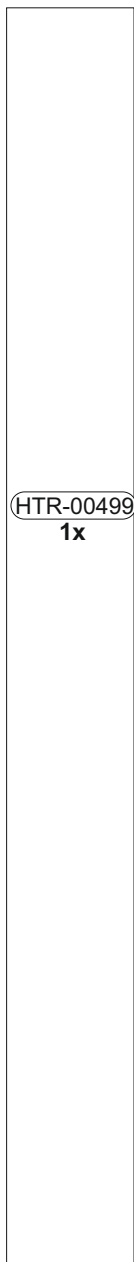

HTR-00499
1x

1779 x 180

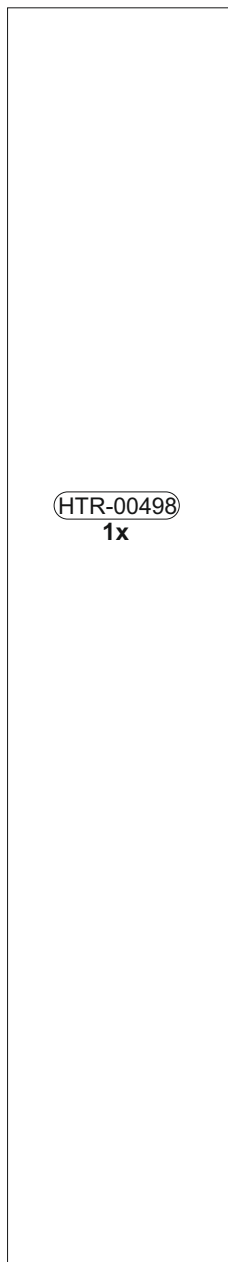

HTR-00498
1x

1779 x 330

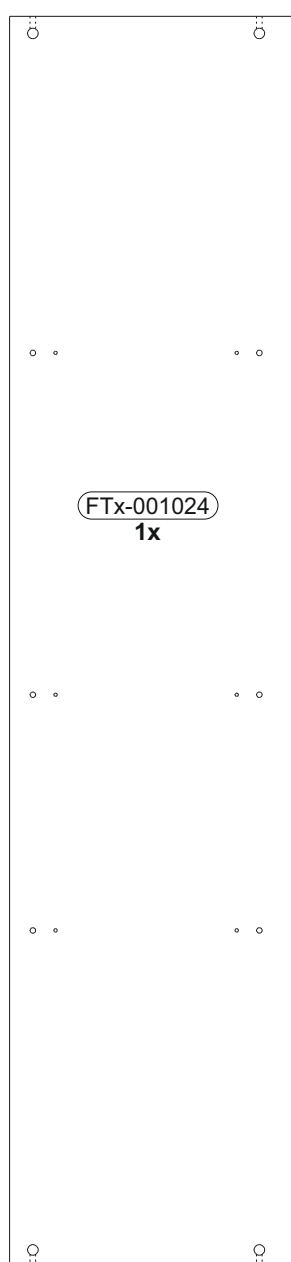

FTx-001024
1x

1767 x 407

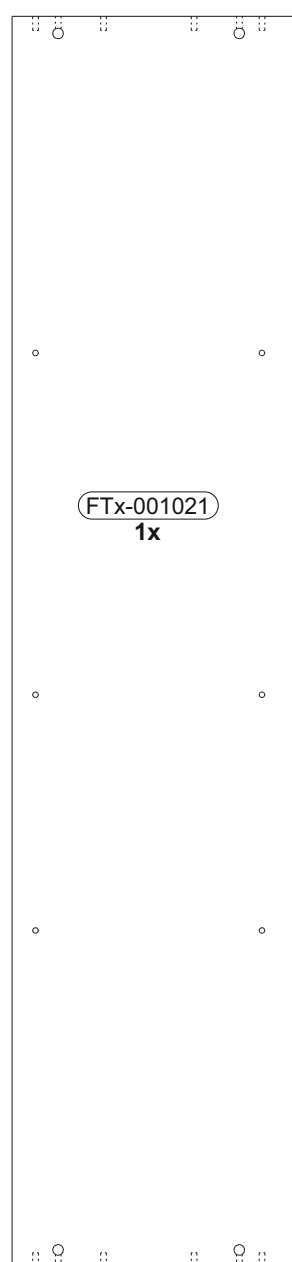

FTx-001021
1x

1767 x 407

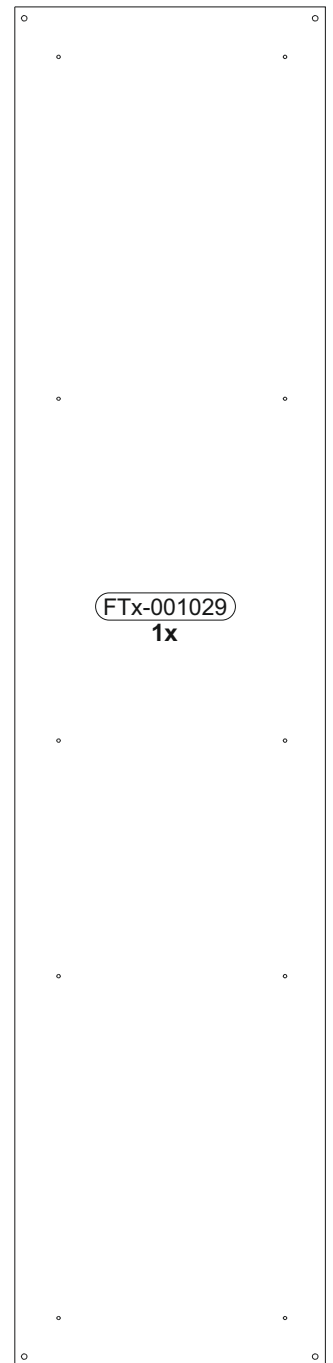

FTx-001029
1x

1923 x 439

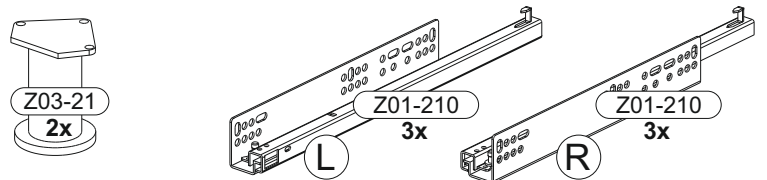
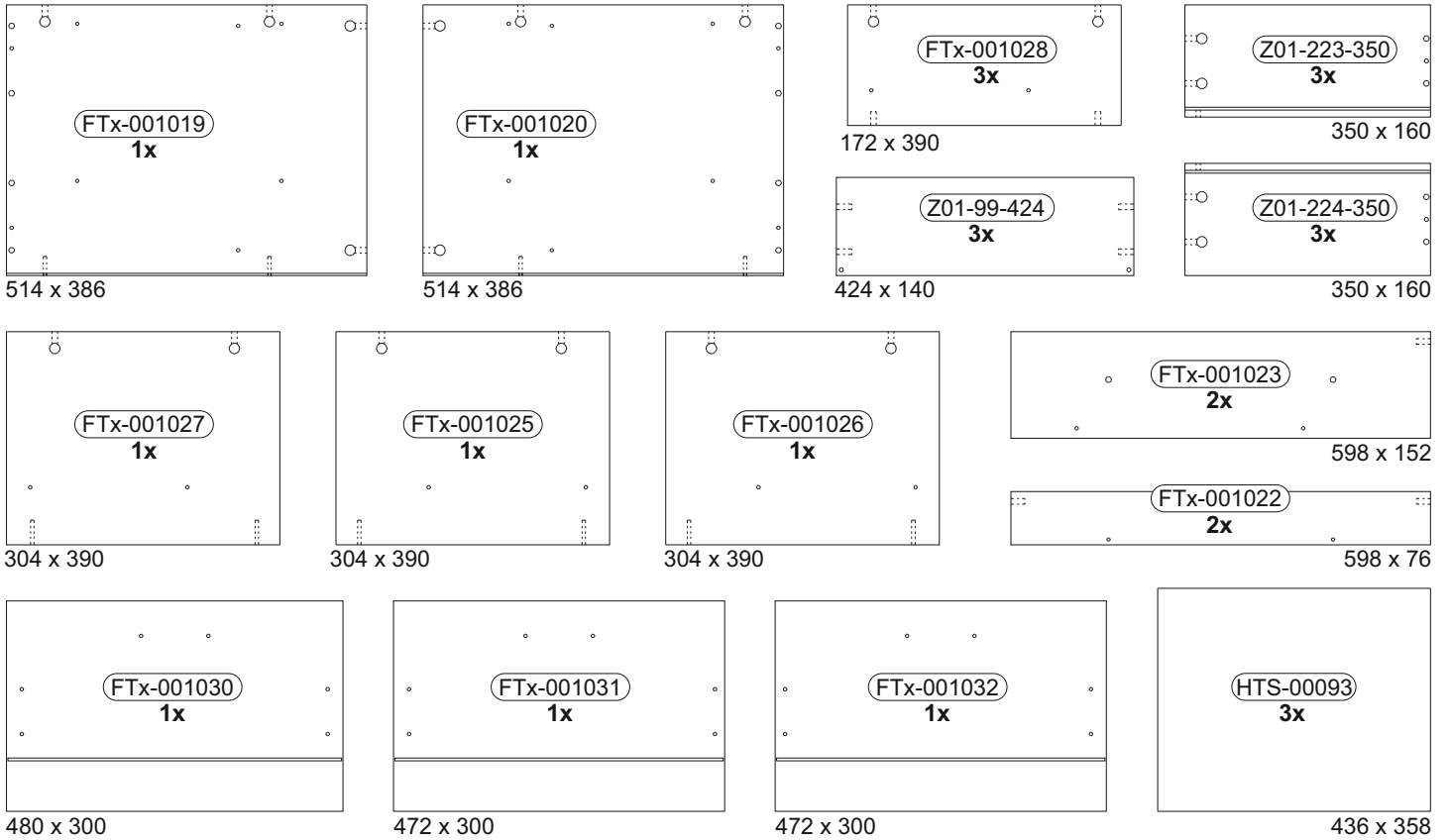

1

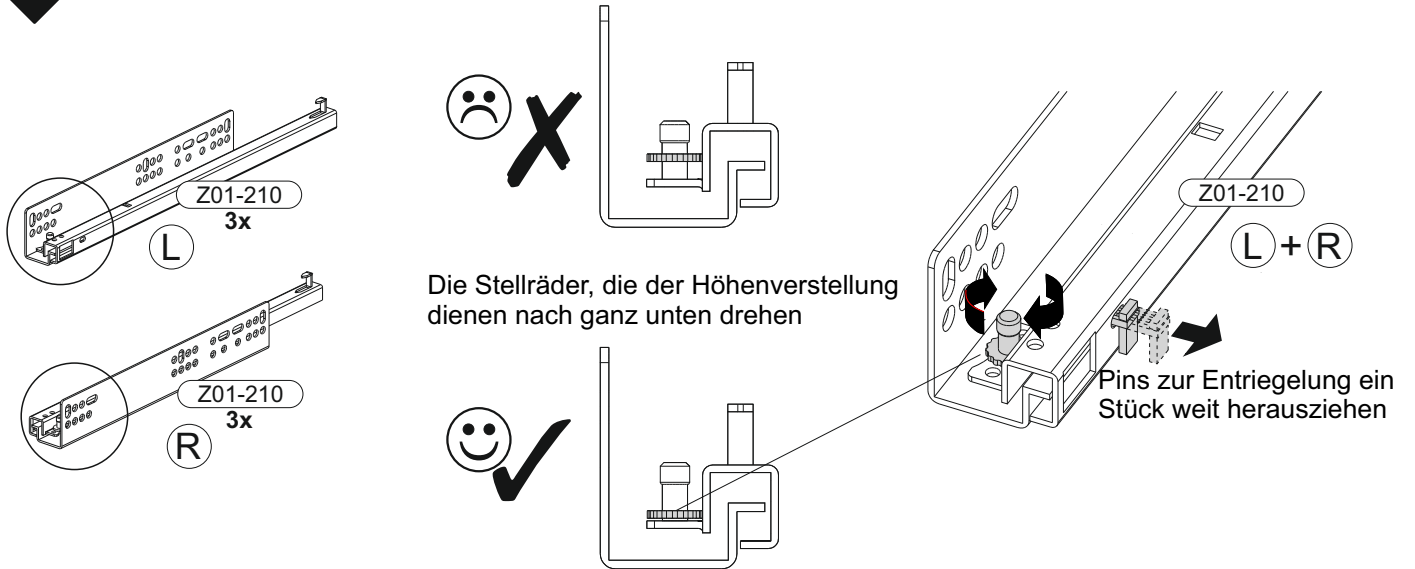

2

	20x	8x	12x	6x	
	$\varnothing 15 \times 12 \text{mm}$			6,3x9,5	

1

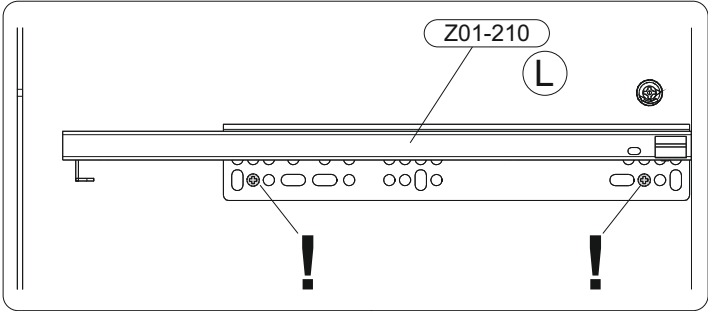
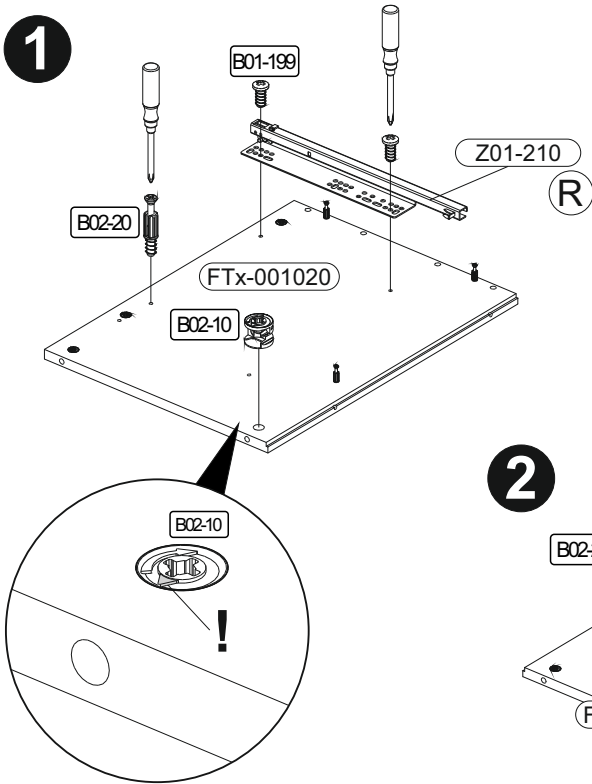

2

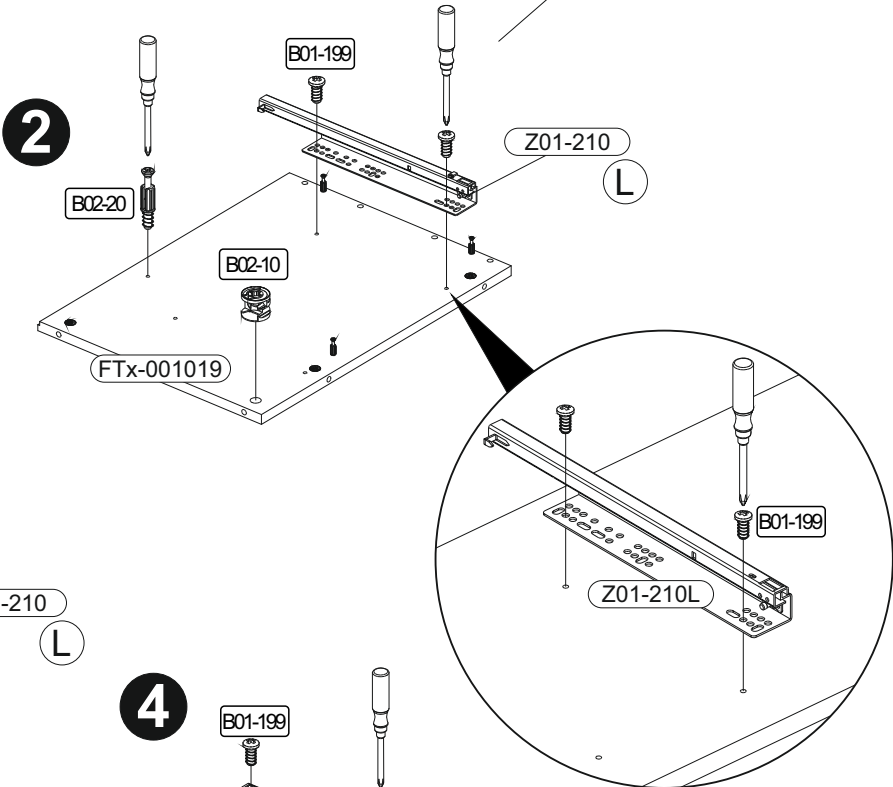

3

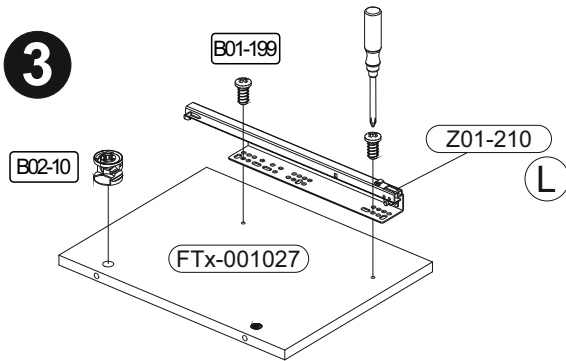

4

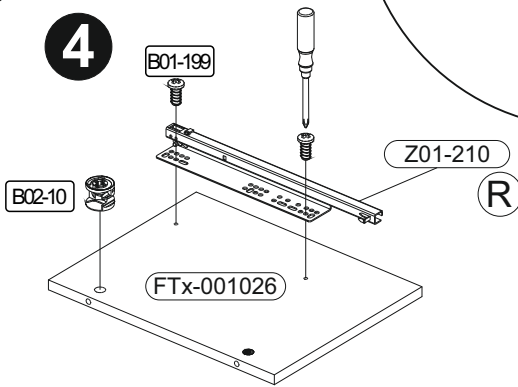

5

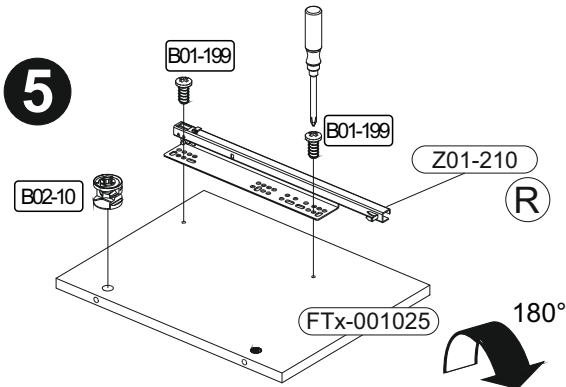

6

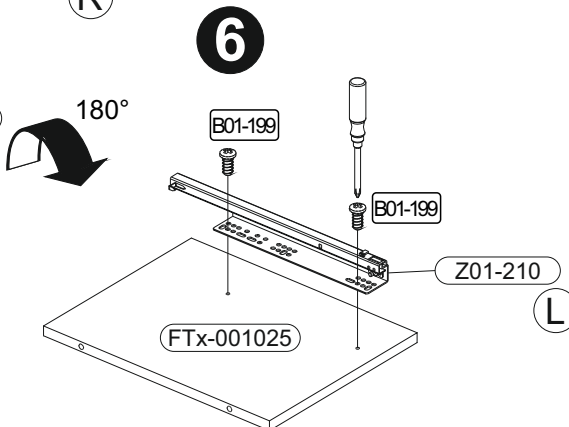

7

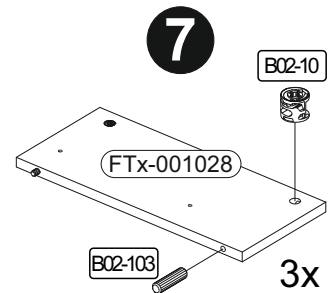

3

	B01-329 6x	 M4x22 15x	B01-30 3x16	B06-440 3x		B02-08 12x	 ø15x10mm	B02-20 12x	
								B01-70 6x	 3x30

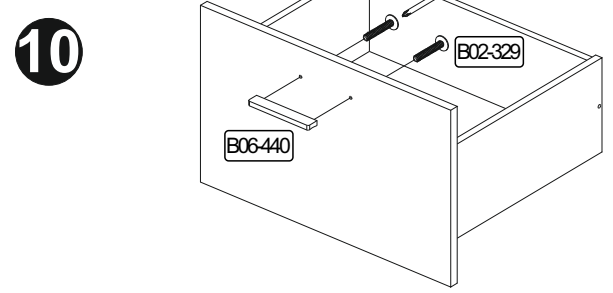
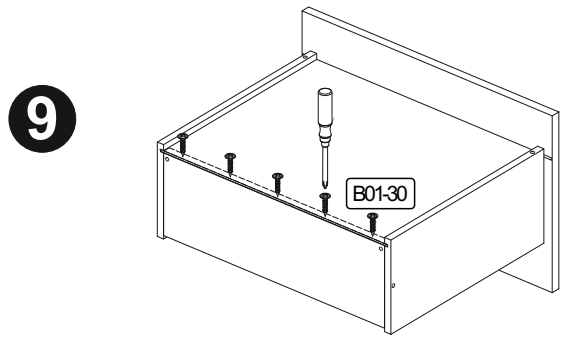
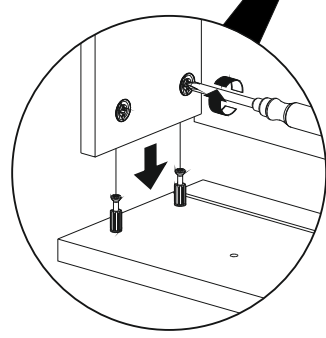
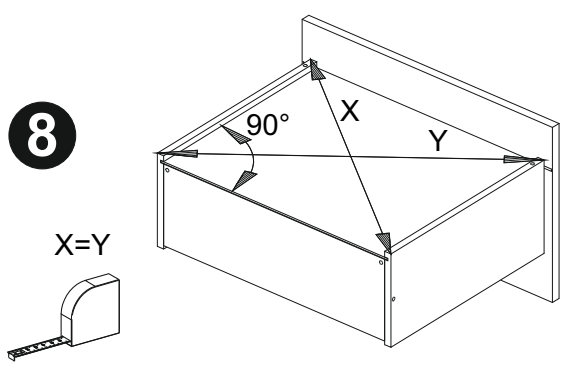
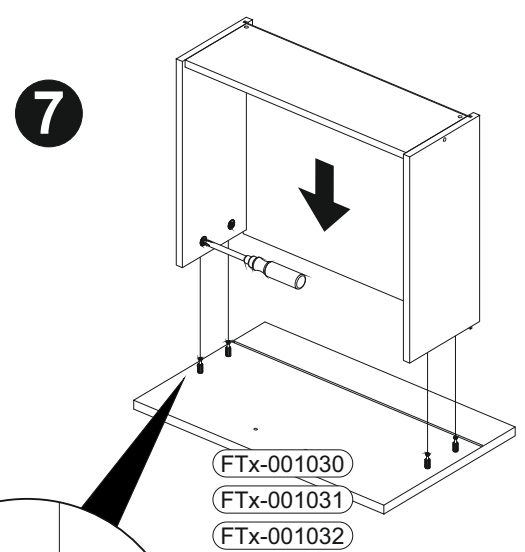
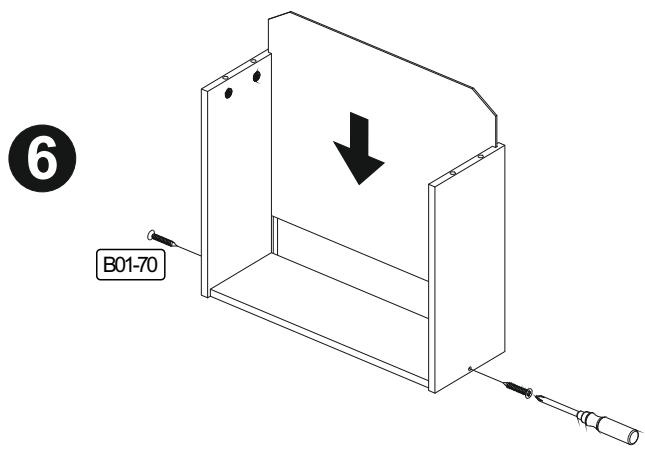
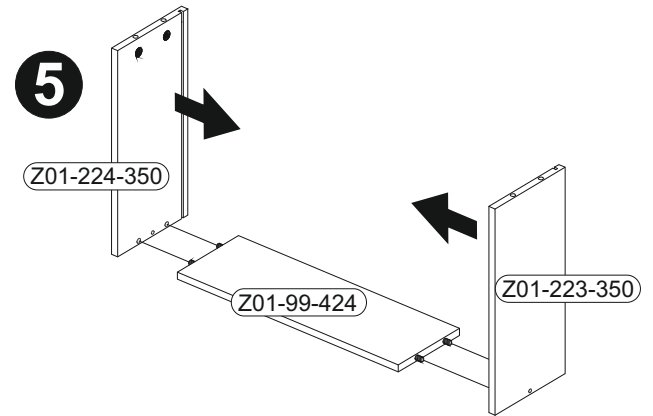
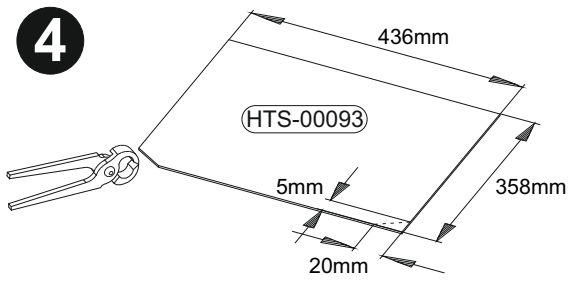
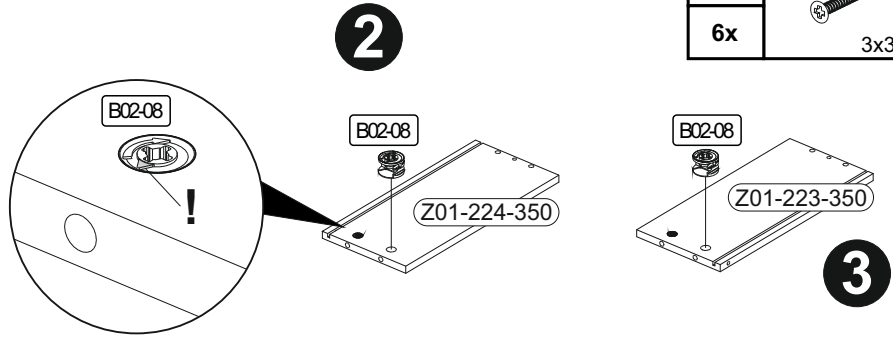
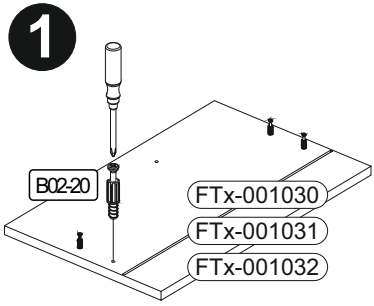

4

	14x	ø15x12mm	20x	8x	8x30	

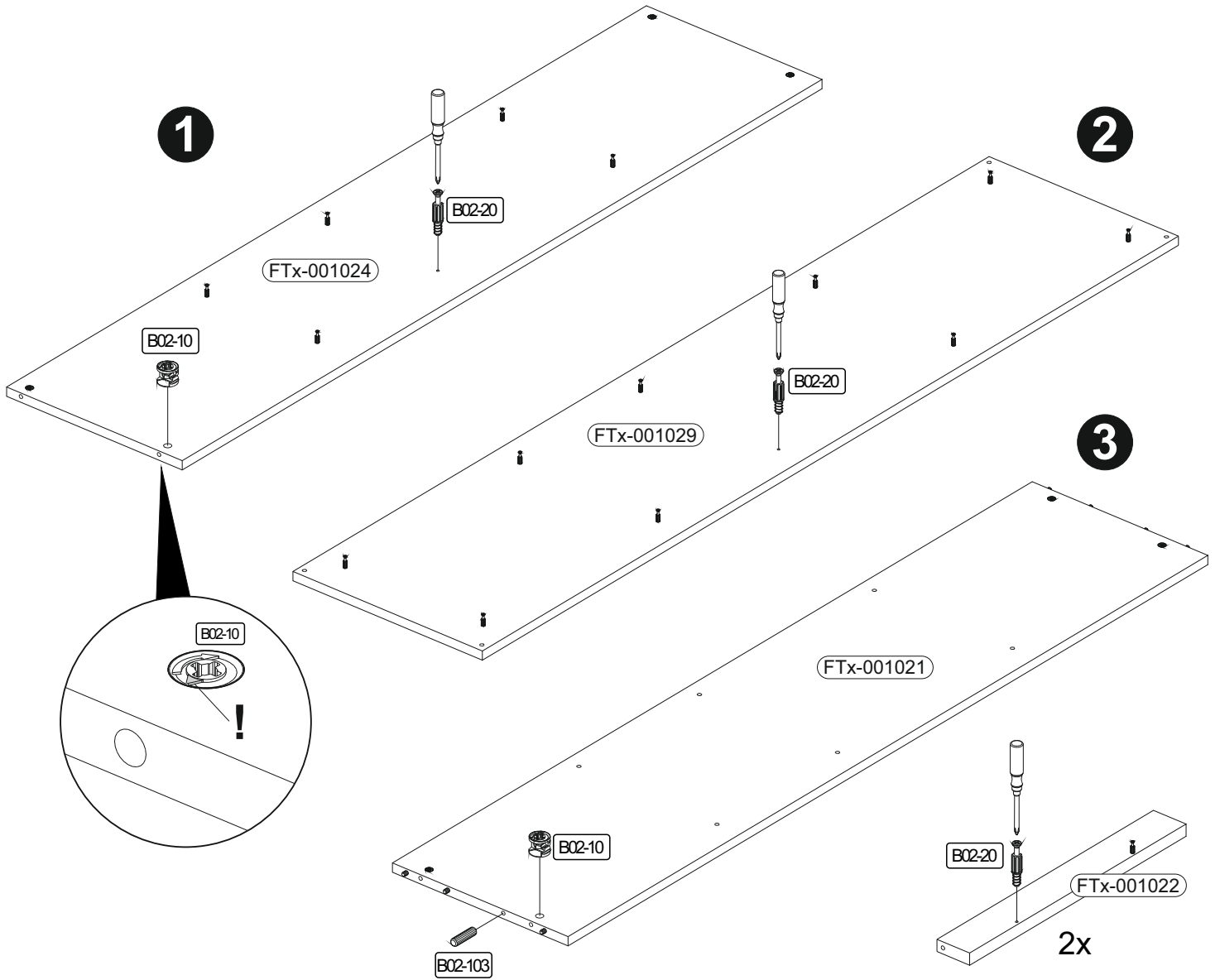

5

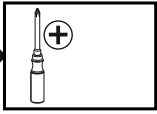

1

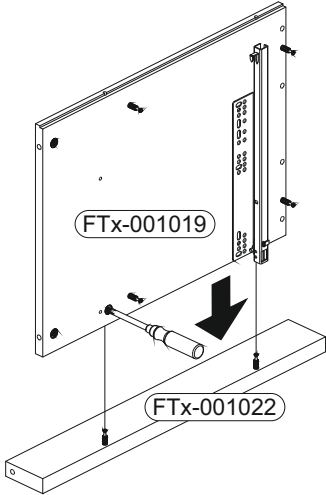

2

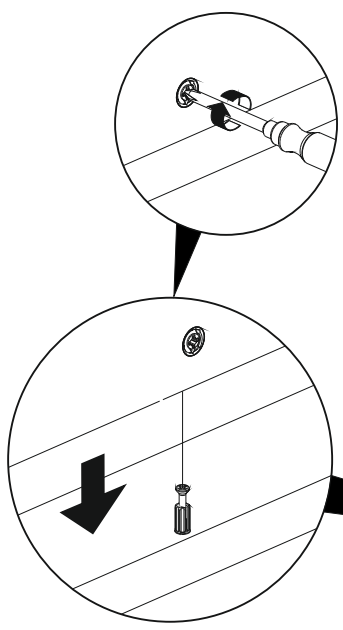
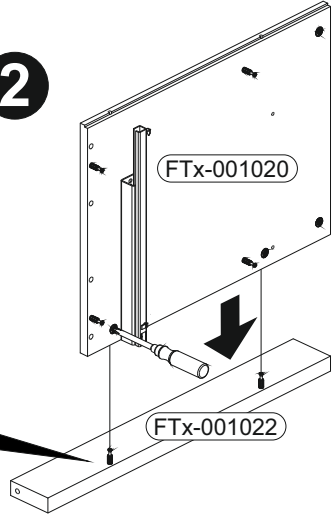

6

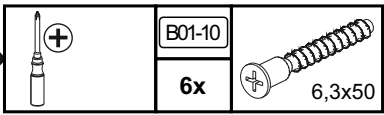

1

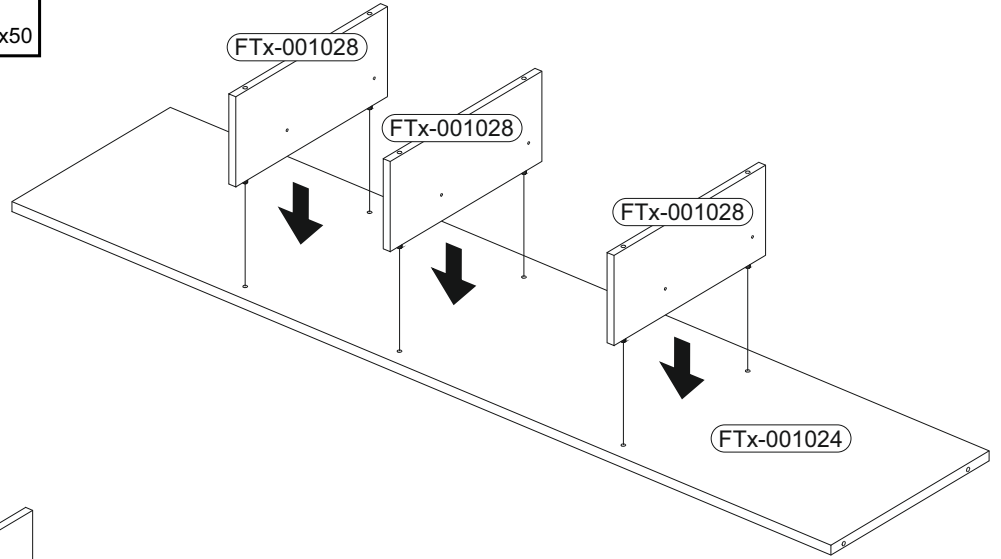

2

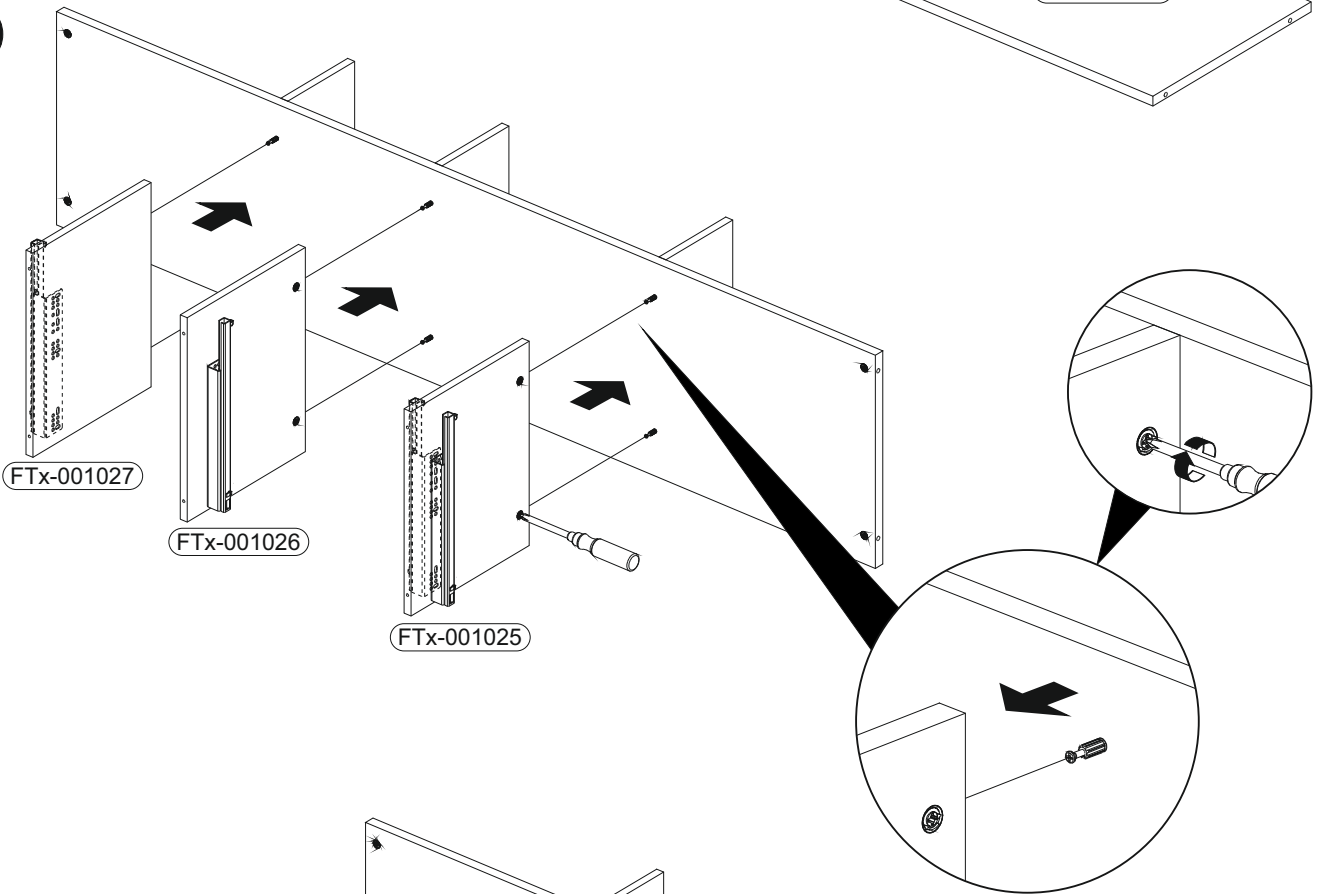

3

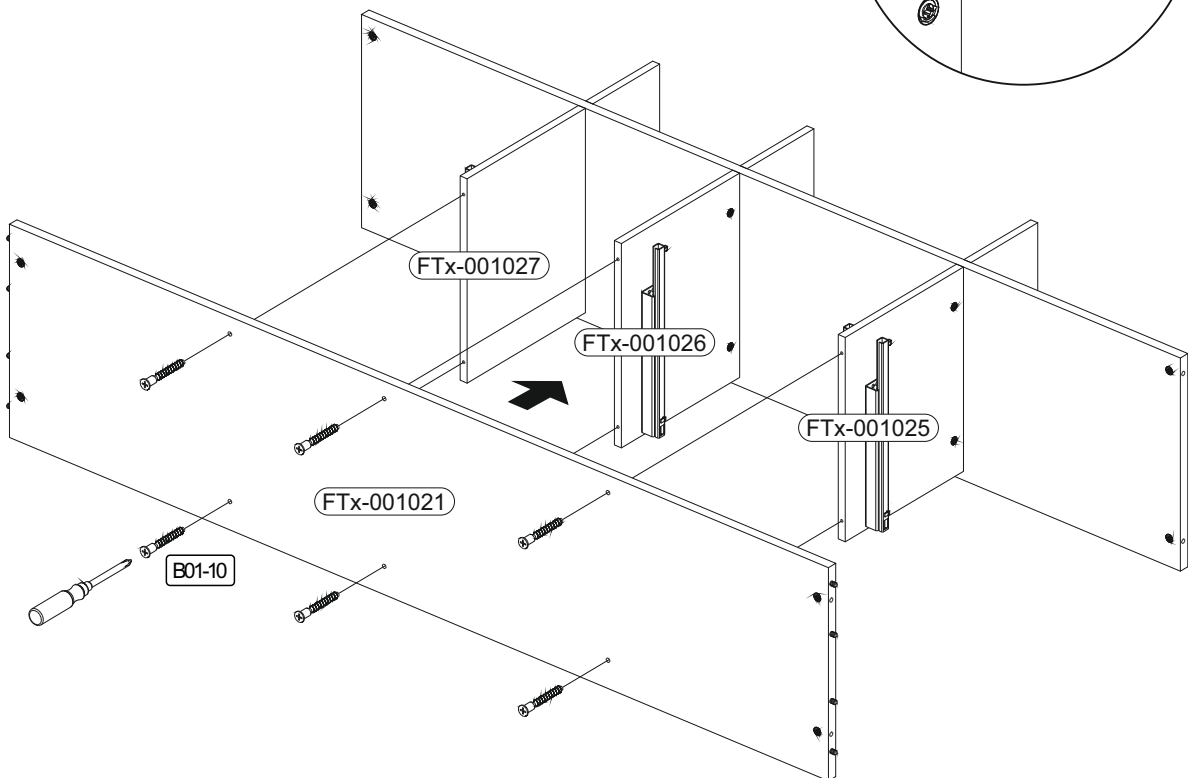

7

	B02-103		B05-130	
2x		8x30	1x	

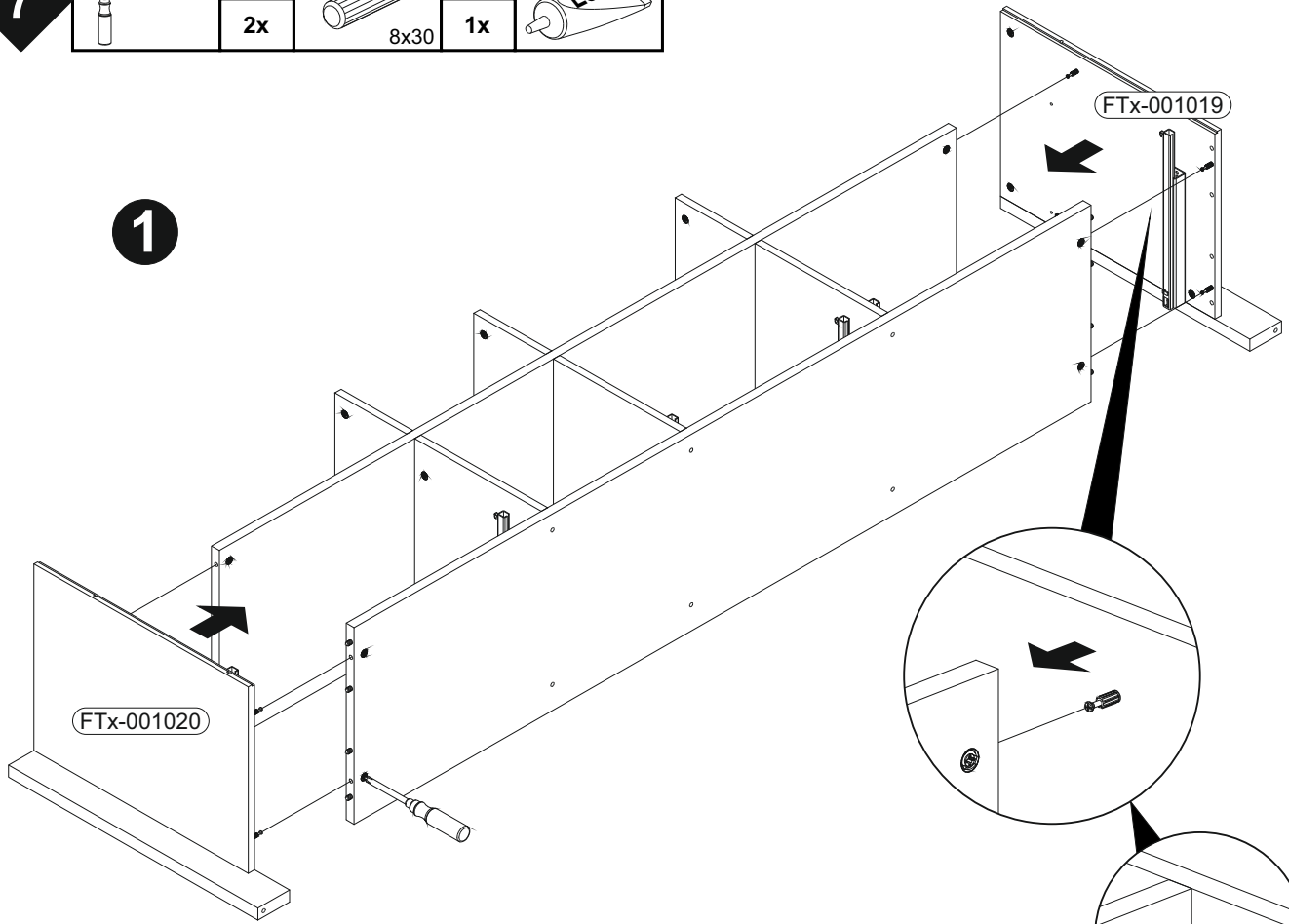

1

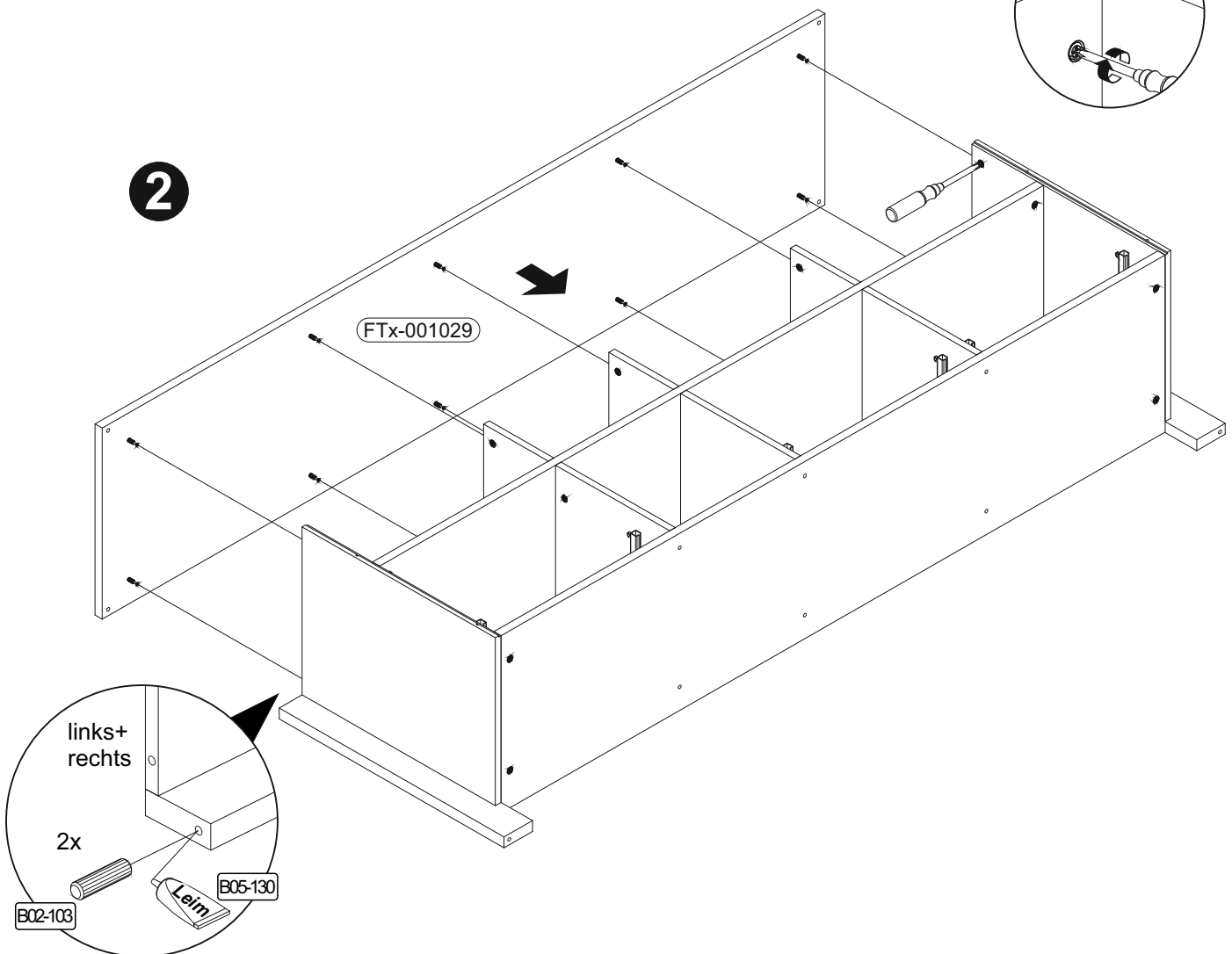

2



8

			
B01-30	43x	3x16	6x
			4,0x17

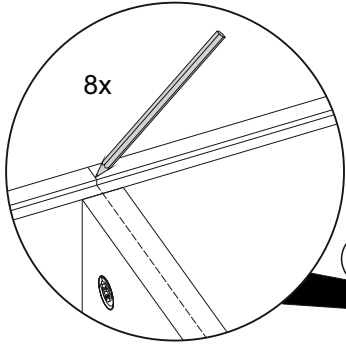

1

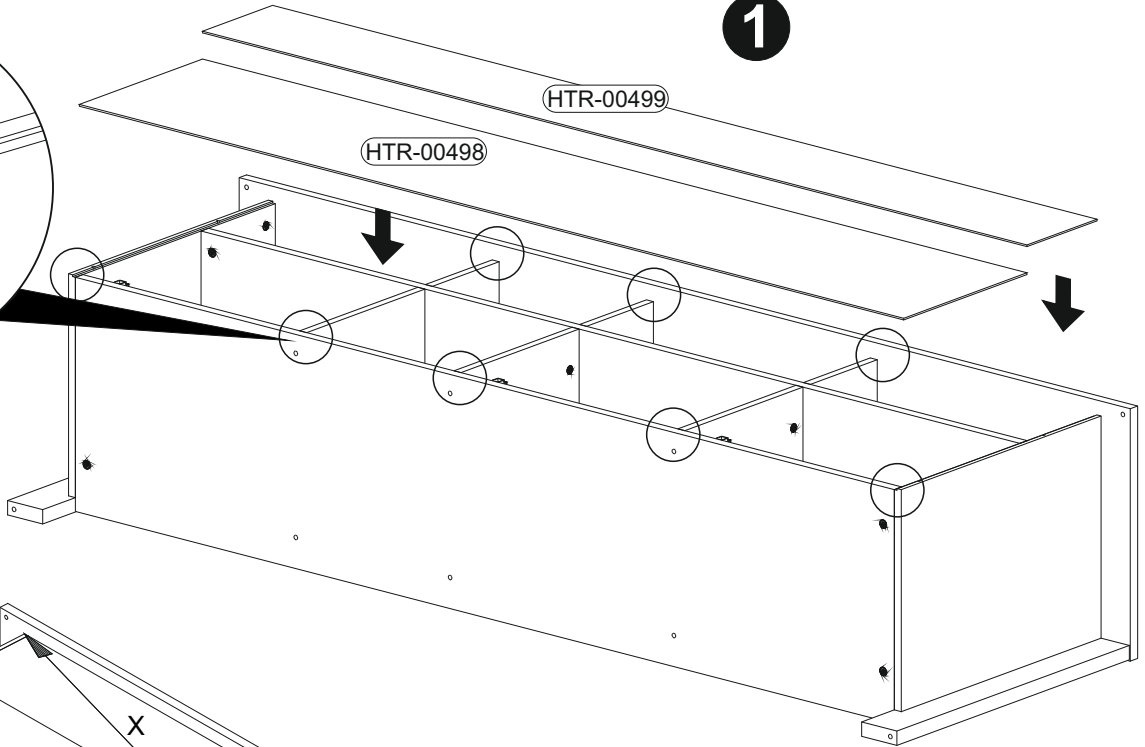

2

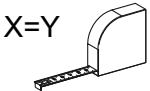
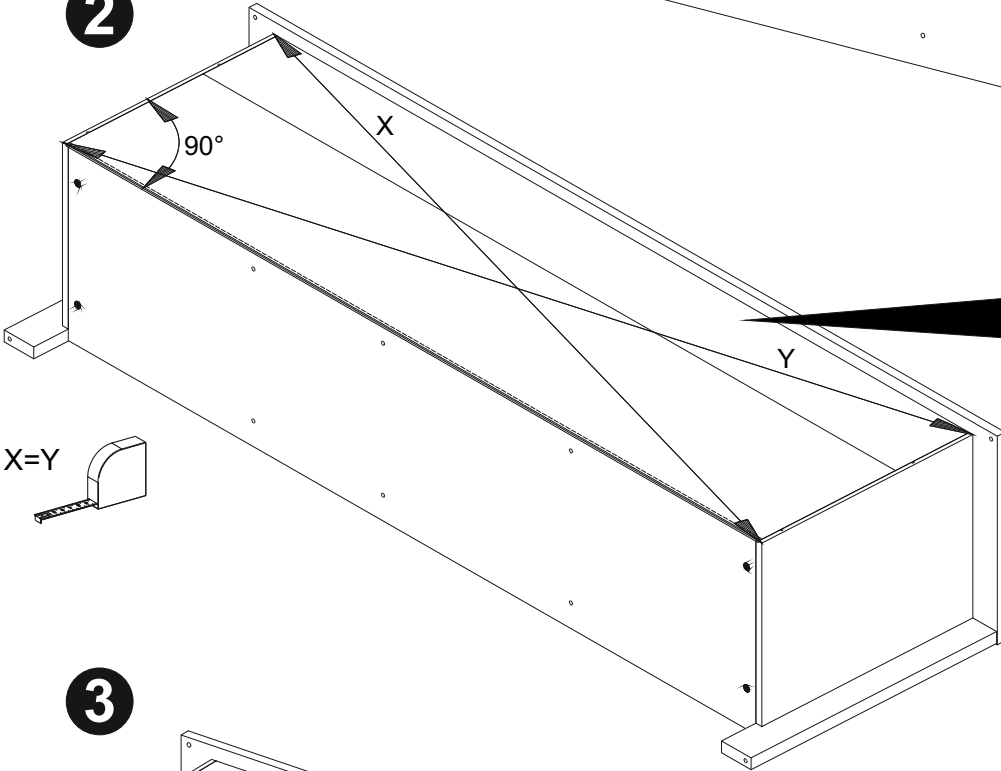

3

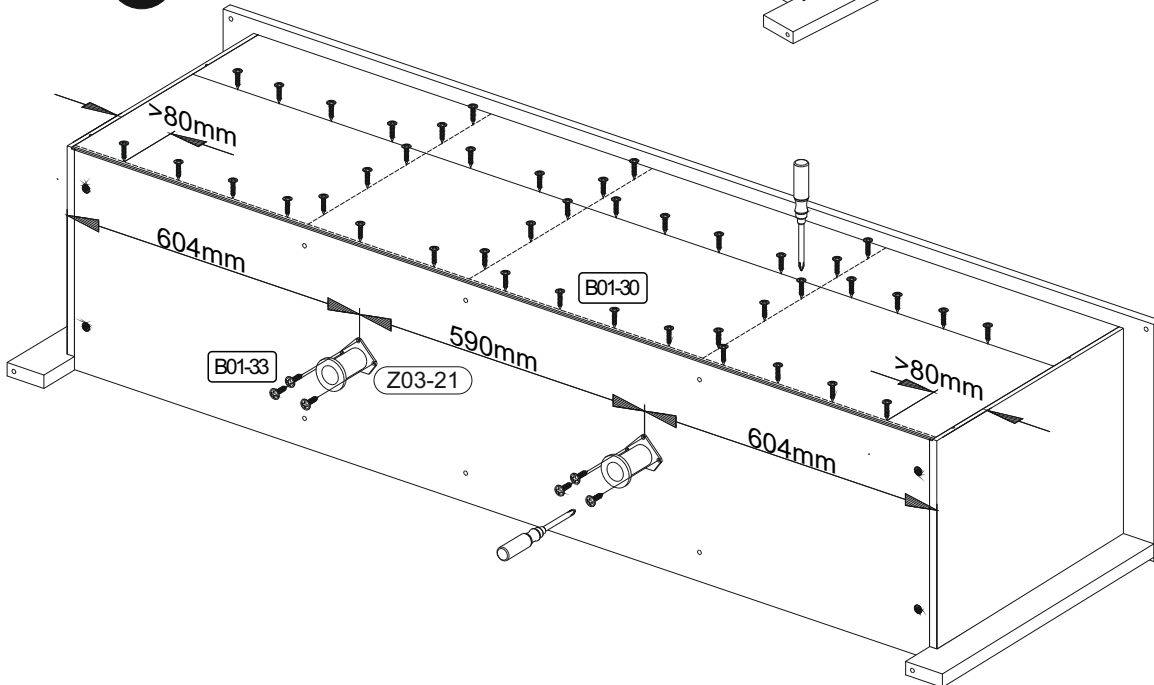

9

	8x	6,3x50	4x	4,5x60	2x
				8x30	1x

1

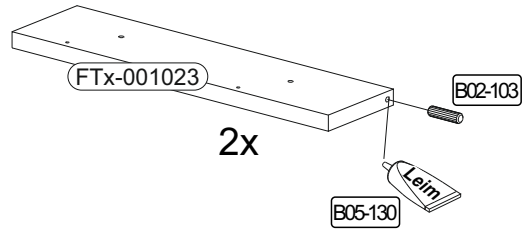

2

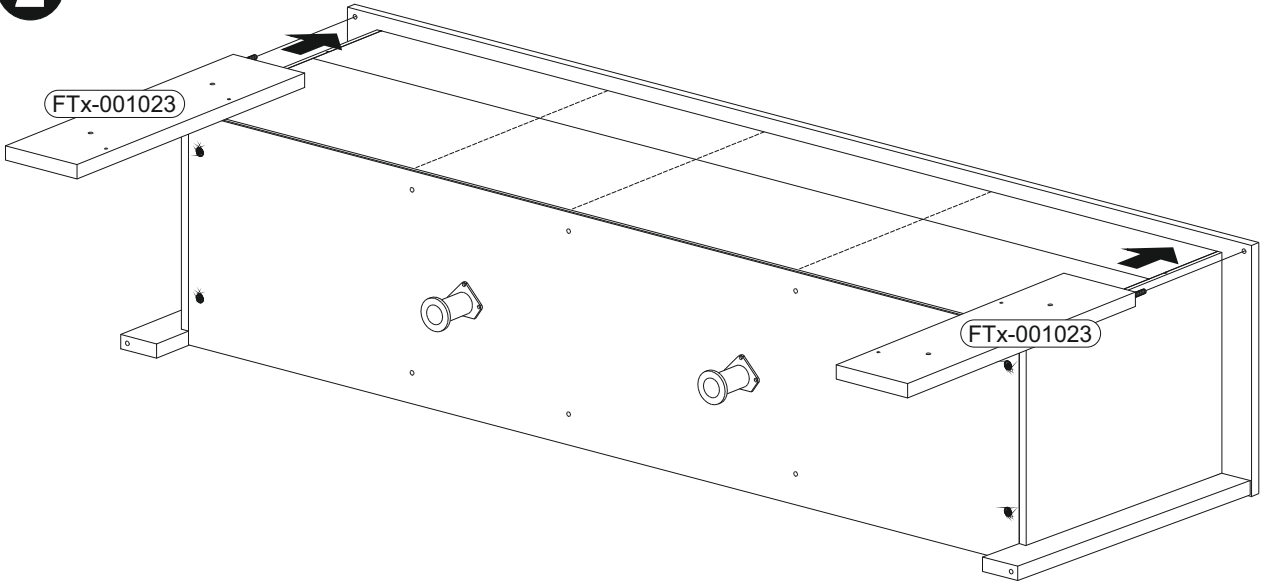

3

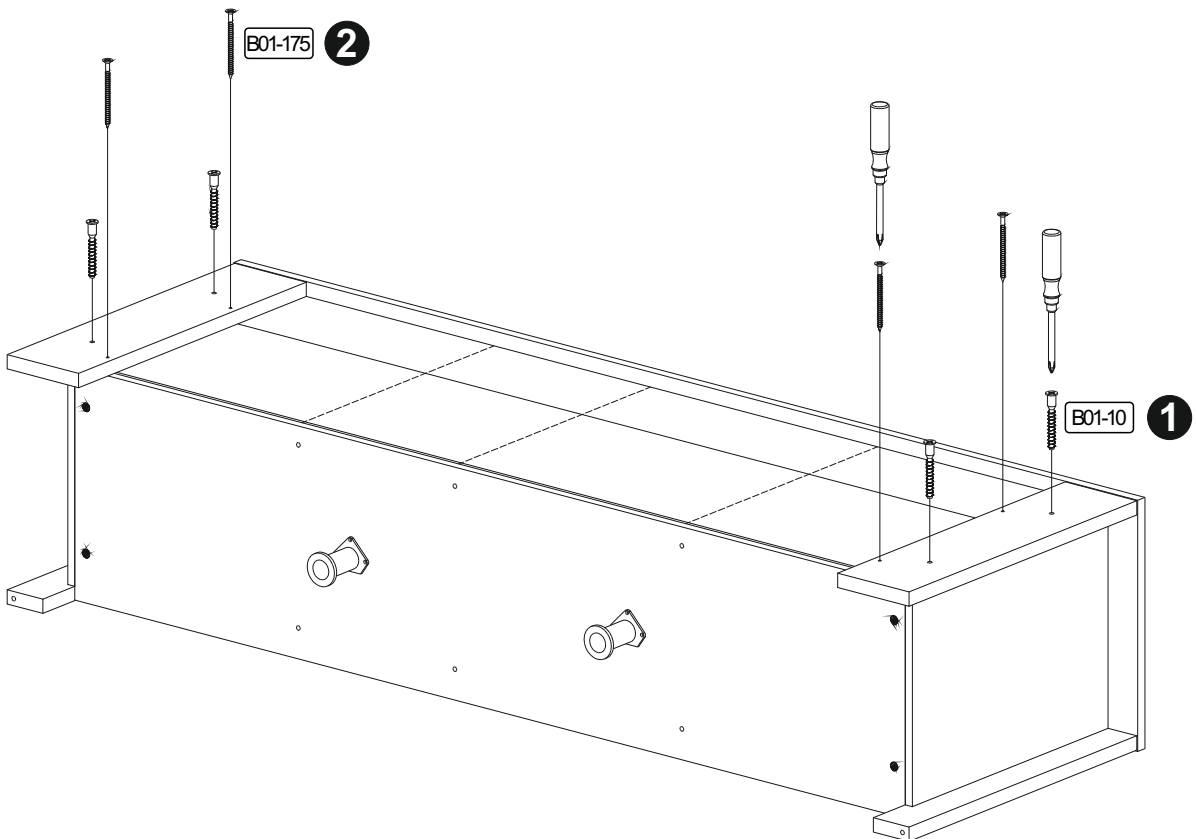

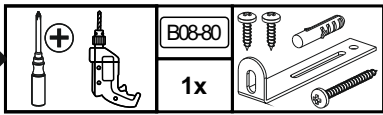

10

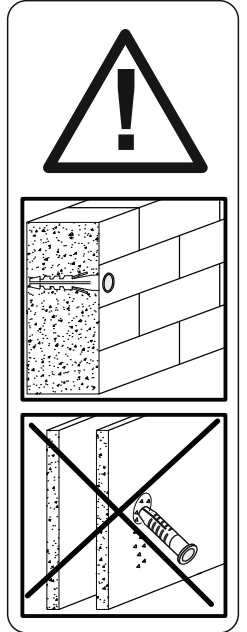
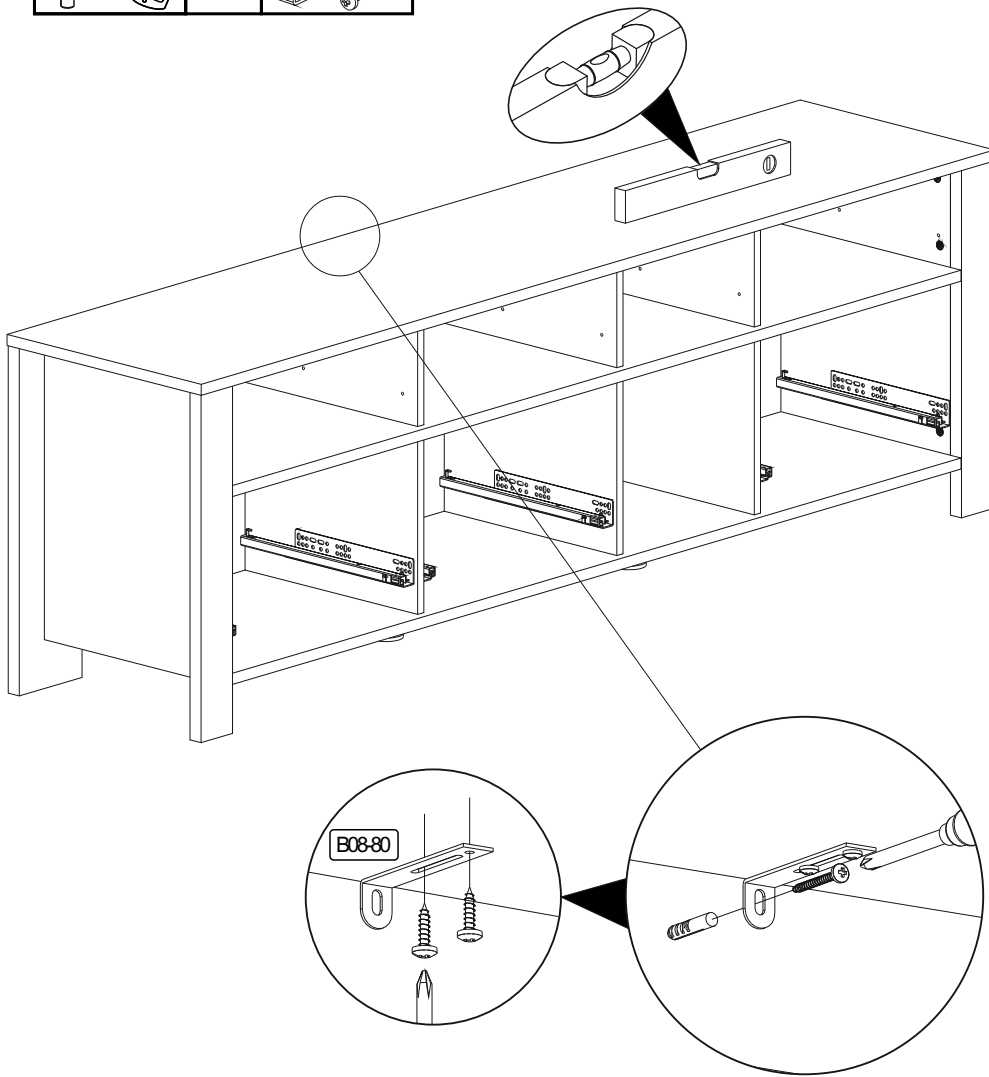

▶ SCAN ME



 Achtung • Attention • Attenzione • Opgelet • Uwaga • Pozor • Figyelem • Atenție • Dikkat • Внимание 	
(D)	Wandbefestigung dient als Kippschutz - unbedingt anbringen! Bei einigen Wandtypen kann ein Spezialdübel erforderlich sein!
(GB)	The wall fastening serves to prevent tipping - be absolutely sure to mount it! For certain wall types, a special wall plug may be necessary!
(FR)	La fixation murale sert de protection contre le basculement – à installer impérativement ! Pour certains types de murs il faut des chevilles spéciales !
(TR)	Duvardaki sabitleme, devrilmeye karşı bir emniyet tedbiridir ve mutlaka monte edilmelidir! Bazı duvar tiplerinde bunun için özel bir dübel gerekli olabilir!
(IT)	Il fissaggio alla parete serve da protezione anti-ribaltamento – attaccarla assolutamente! Per alcune strutture di parete può essere necessario un tassello speciale!
(NL)	Bevestiging aan de muur dient als kantelbescherming – zeker en vast bevestigen! Bij enkele muurtypes is een speciale plug misschien vereist!
(RU)	Обязательно установите крепление на стене во избежание опрокидывания! Для некоторых типов стен может потребоваться специальный дюбель!
(CZ)	Montáž na stěnu slouží jako ochrana proti převrnutí – bezpodmínečně umístěte! U některých typů stěn může být zapotřebí speciální hmoždinka!
(HU)	A termék a falhoz kel rögzíténi, különben az felborulhat! Egyes faltípusoknál speciális tiplit kell használni!
(RO)	Sistemul de fixare la perete servește ca protecție la răsturnare - de montat obligatoriu! Pentru unele tipuri de pereți este posibil să fie necesar un diblu special!
(PL)	Mocowanie do ściany jest jednocześnie zabezpieczeniem przed przewróceniem – koniecznie zamontować! Do niektórych rodzajów ścian konieczne zastosować specjalne kołki mocujące.
(SK)	Upevnenie na stenu slúži ako ochrana proti prevráteniu – bezpodmienečne použite! Pre niektoré druhy stien môže byť potrebná špeciálna hmoždinka!

11

	6x		6x		4x		12x	
		ø20mm		ø20mm		ø14mm		ø14mm

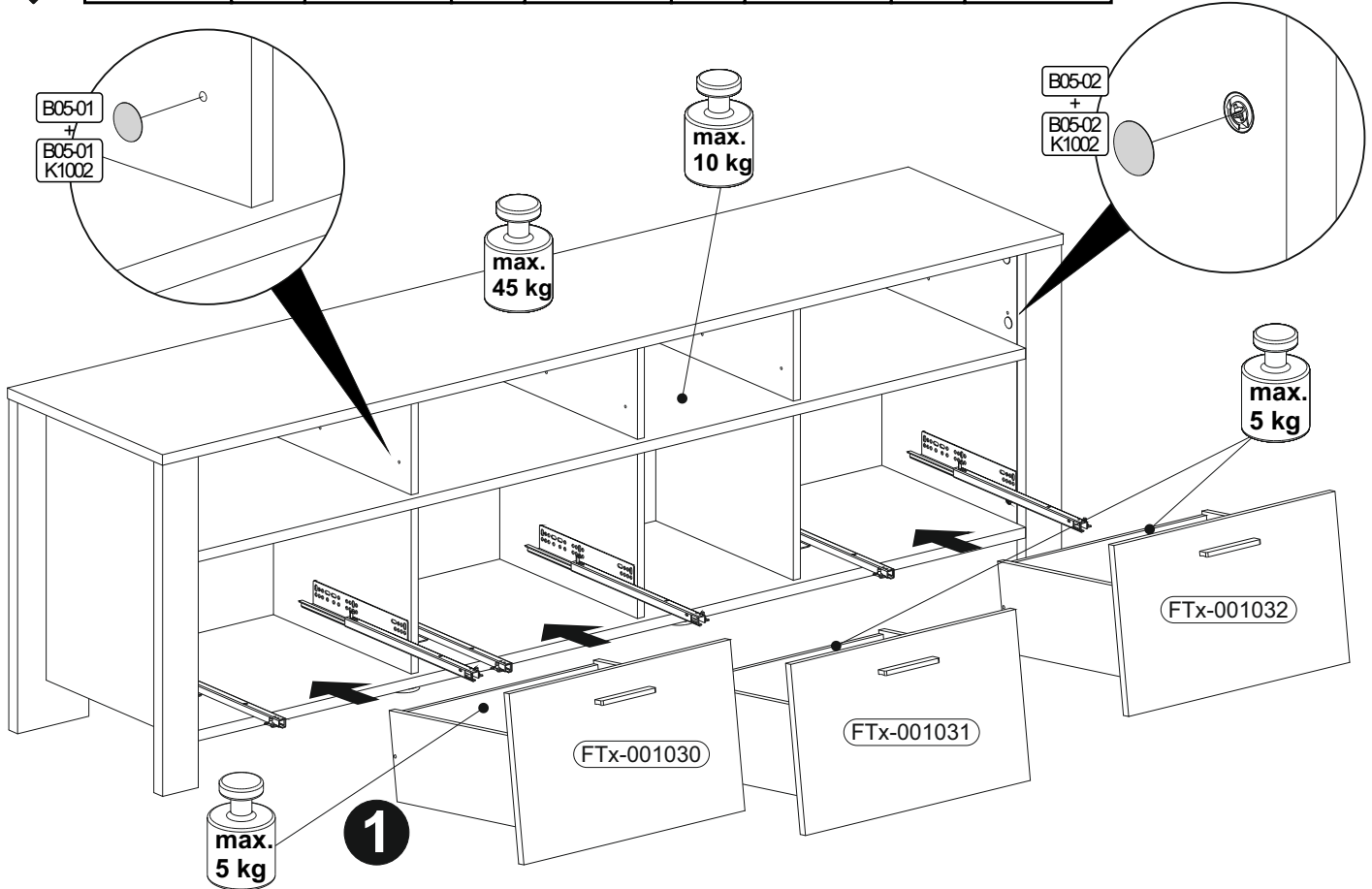

SCAN ME

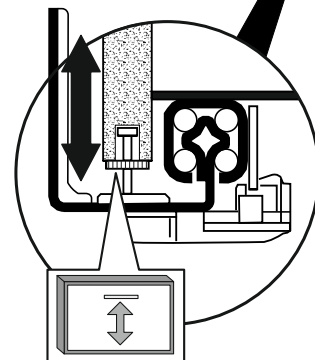
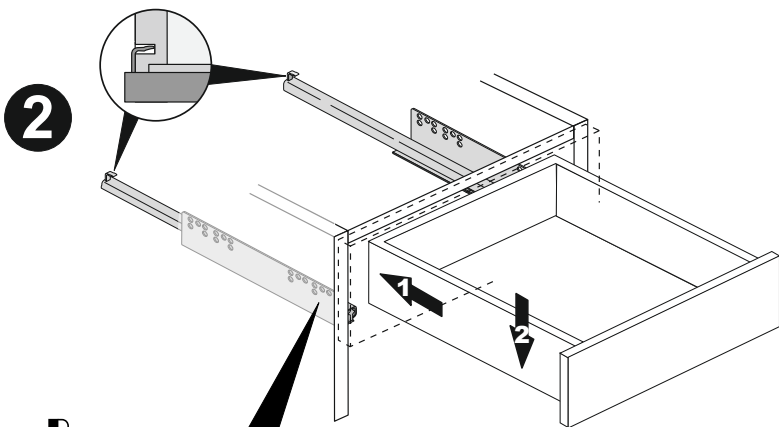
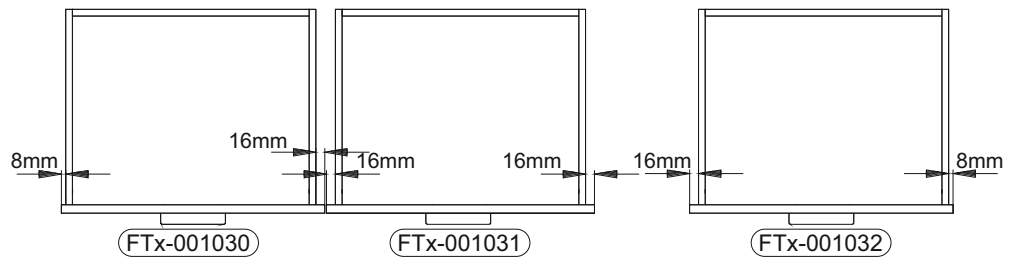

Höhenverstellung des Schubkastens

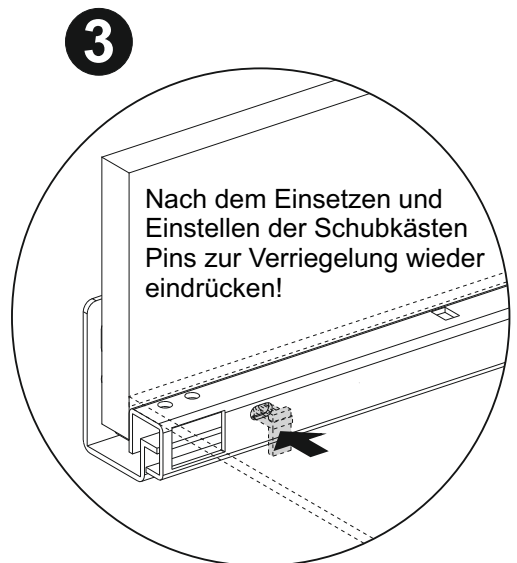

2

5

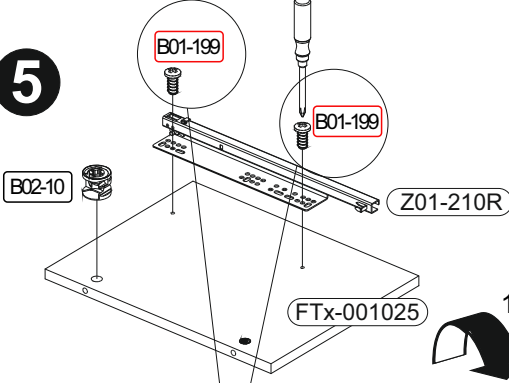

6

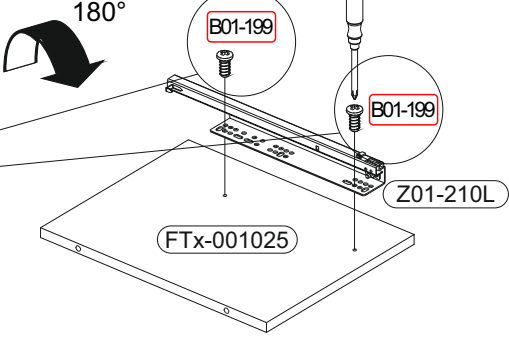

!!!

B01-199	
4x	6,3x9,5

2

5

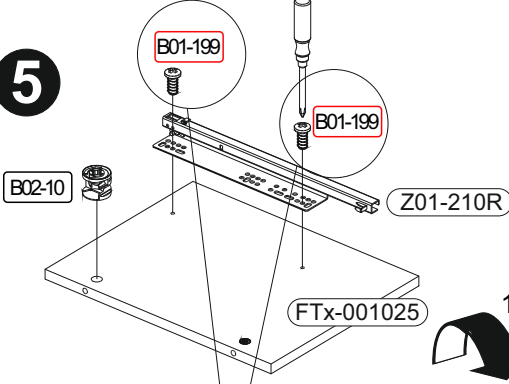

6

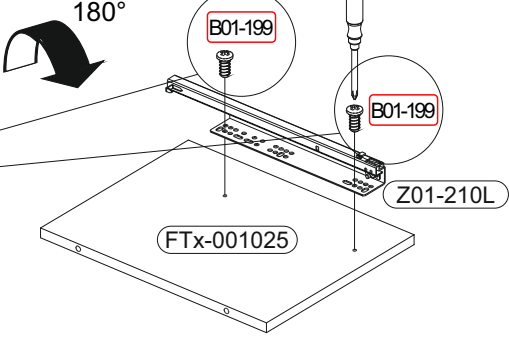

!!!

B01-199	
4x	6,3x9,5



(D) Videounterstützte Montageanleitung

(TR) Video destekli kurulum talimatları

(RU) инструкция по монтажу с помощью видеосигнала

(RO) Instrucțiuni de instalare acceptate video

(GB) Video-assisted assembly instructions

(IT) Istruzioni di montaggio video-assistite

(CZ) Instalační pokyny podporované videem

(PL) Instrukcje montażu wspomagane sygnałem wizyjnym

(FR) Instructions de montage assistées par vidéo

(NL) Video-ondersteunde montage-instructies

(HU) Video-támogatott telepítési utasítások

(SK) Inštaláčne pokyny podporované videom

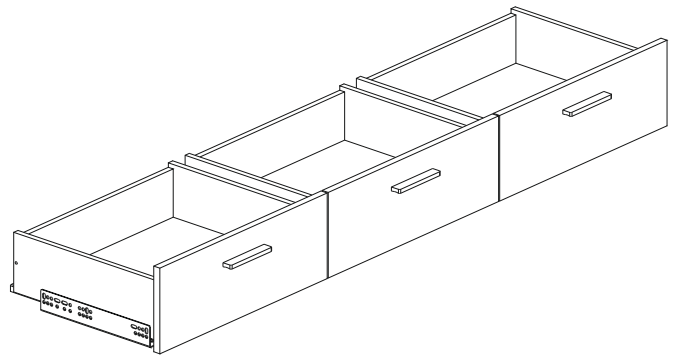
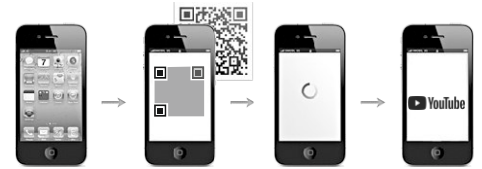
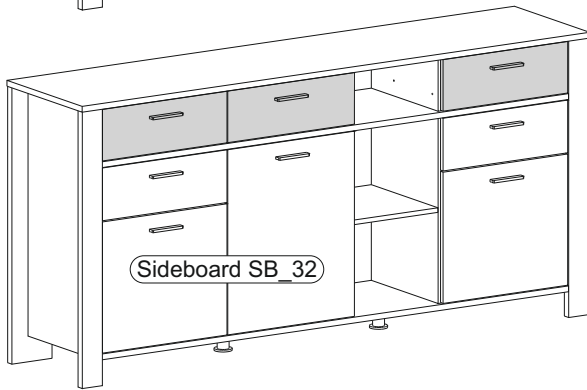
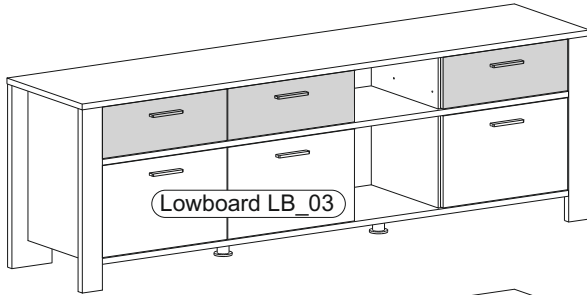

0622-SK_3er Set Schubkästen

REPC-Nr.:



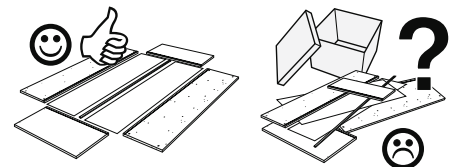
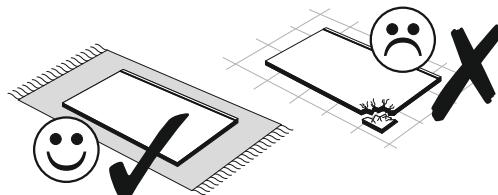
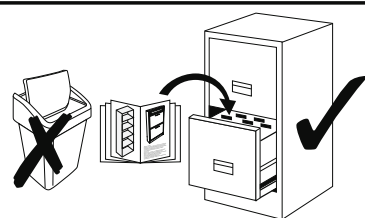
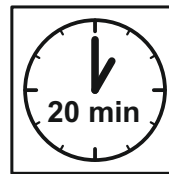
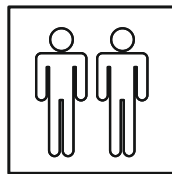
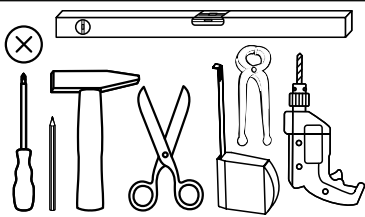



Service • Assistenza • Dienstverlening • Serwis
Servis • Szerviz • Сервисная служба



SCAN ME

Das Ersatzteil-Anforderungsformular finden Sie auf
The replacement parts requisition form you find on
<https://www.maeusbacher.de/ersatzteile/>

BT1-00387 Colli 1/1

B02-08		B02-20		B01-30		B01-70		B01-329		B01-199	
12x	ø15x10mm	12x		15x	3x16	6x	3x30	6x	M4x22	12x	6,3x9,5

BT1-00388 Colli 1/1

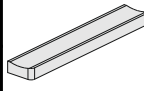
B06-440	
3x	

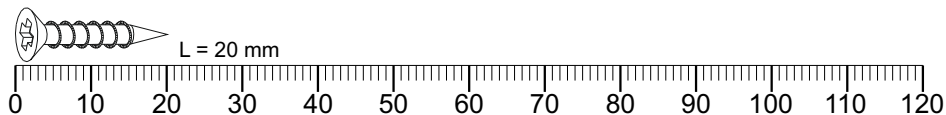

▶ SCAN ME

Colli 1/1

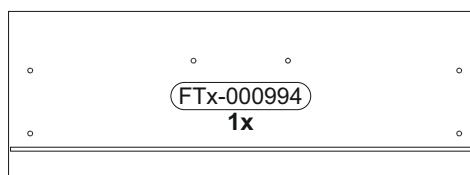

472 x 168

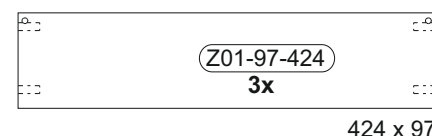
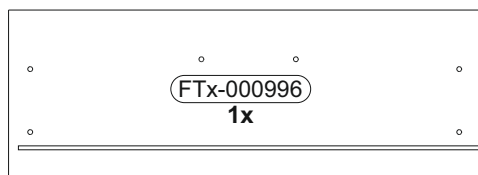
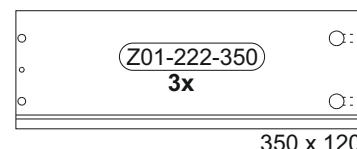
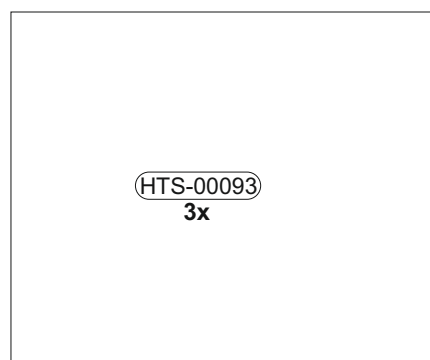
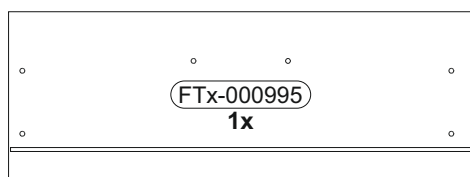
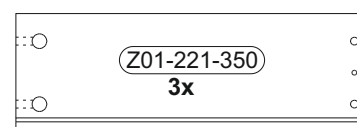
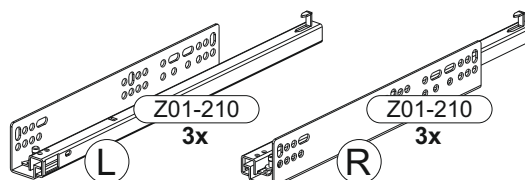

1

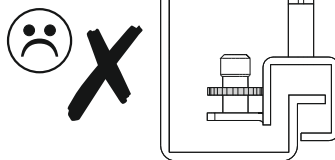
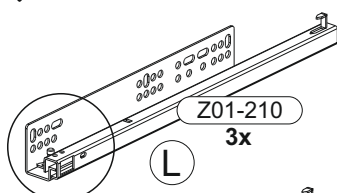

Die Stellräder, die der Höhenverstellung dienen nach ganz unten drehen

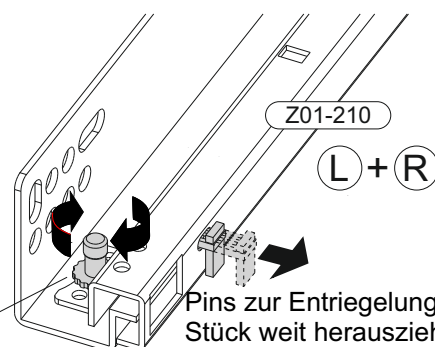
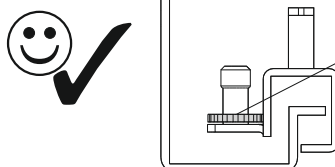
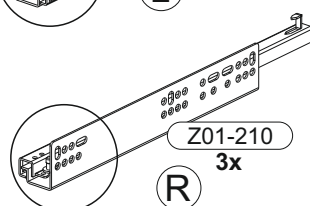

2

	B01-329 6x	 M4x22 15x	B01-30 3x16	B06-440 3x		B02-08 12x	 ø15x10mm 12x	B02-20 12x	 3x30
								B01-70 6x	

1

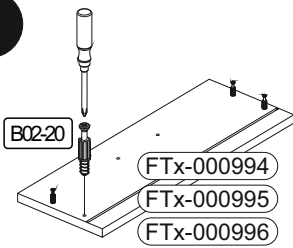

2

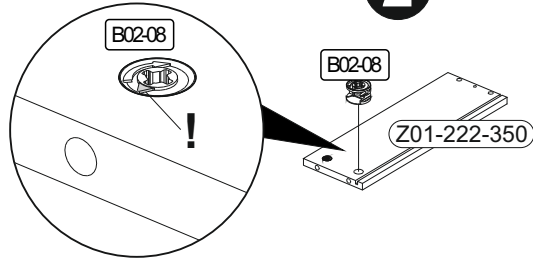

3

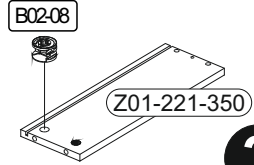

4

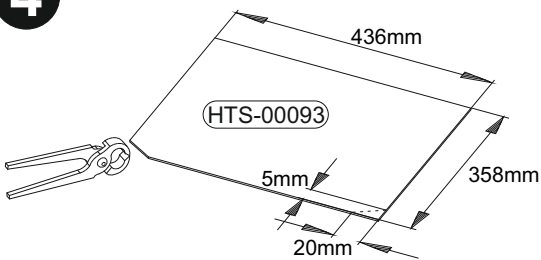

5

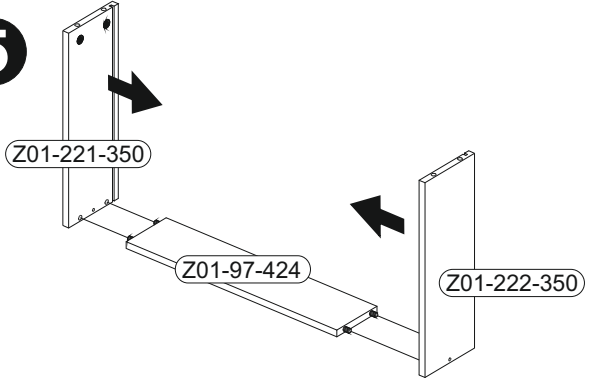

6

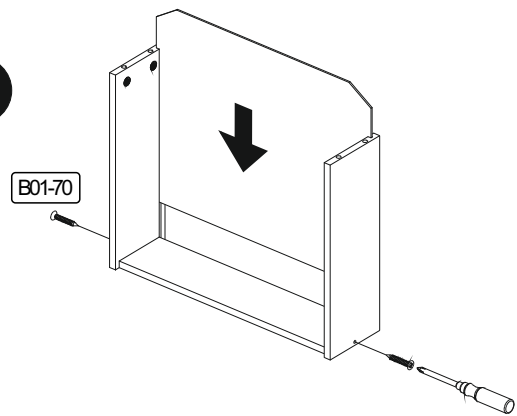

7

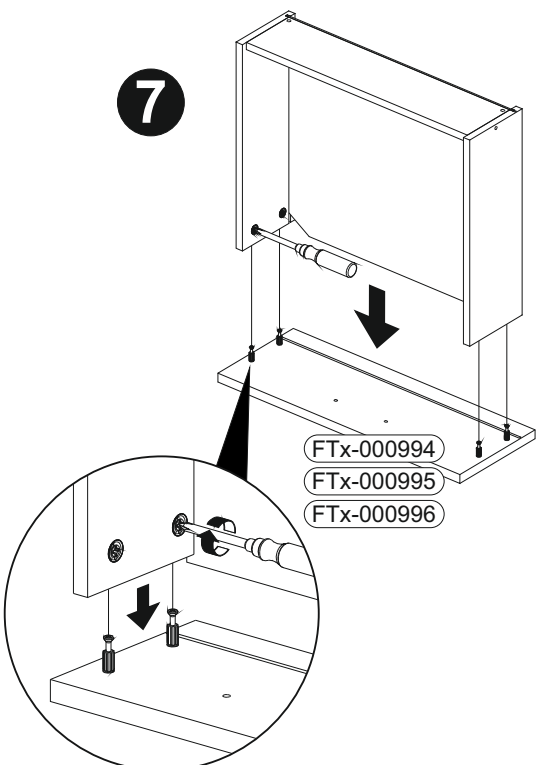

8

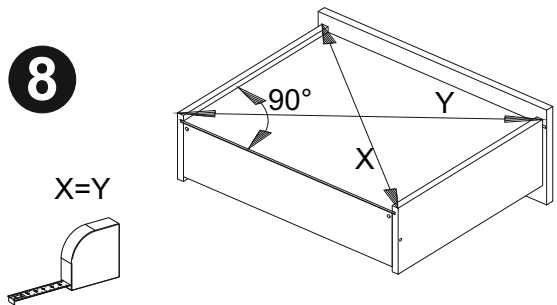

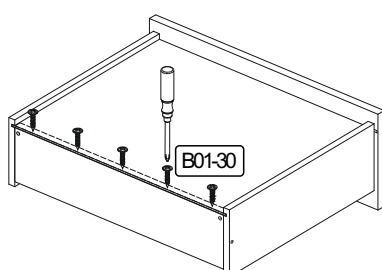

9

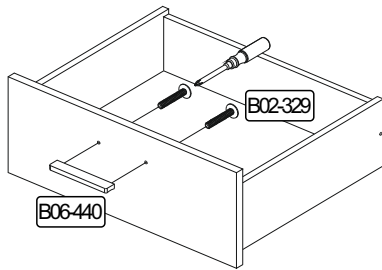

10



3

	B01-199	
	12x	6,3x9,5

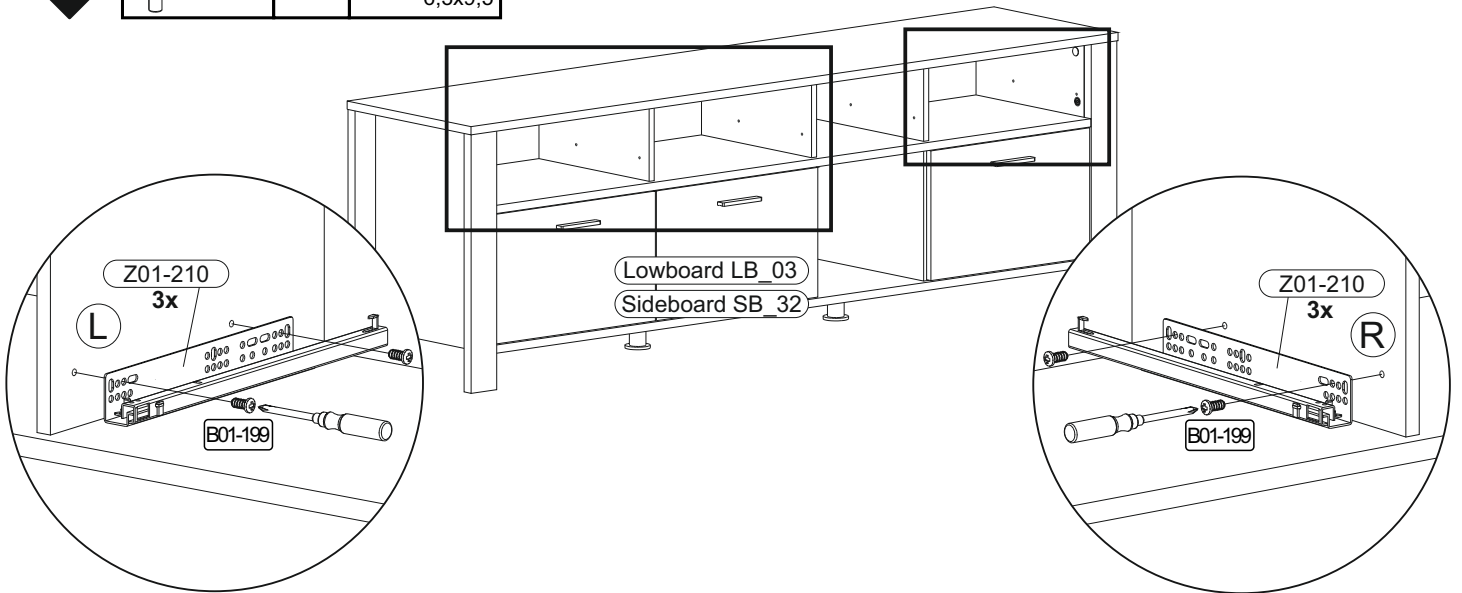

4

Höhenverstellung des Schubkastens



▶ SCAN ME

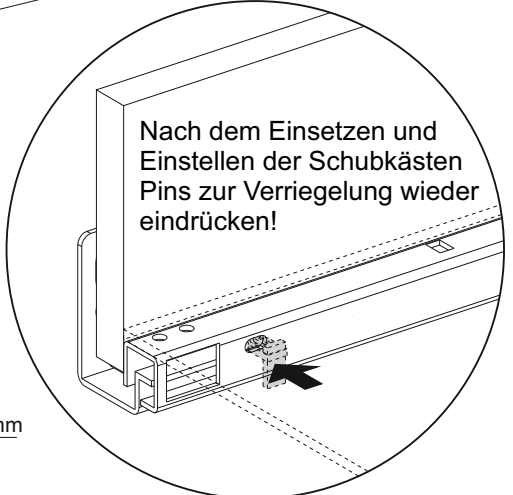
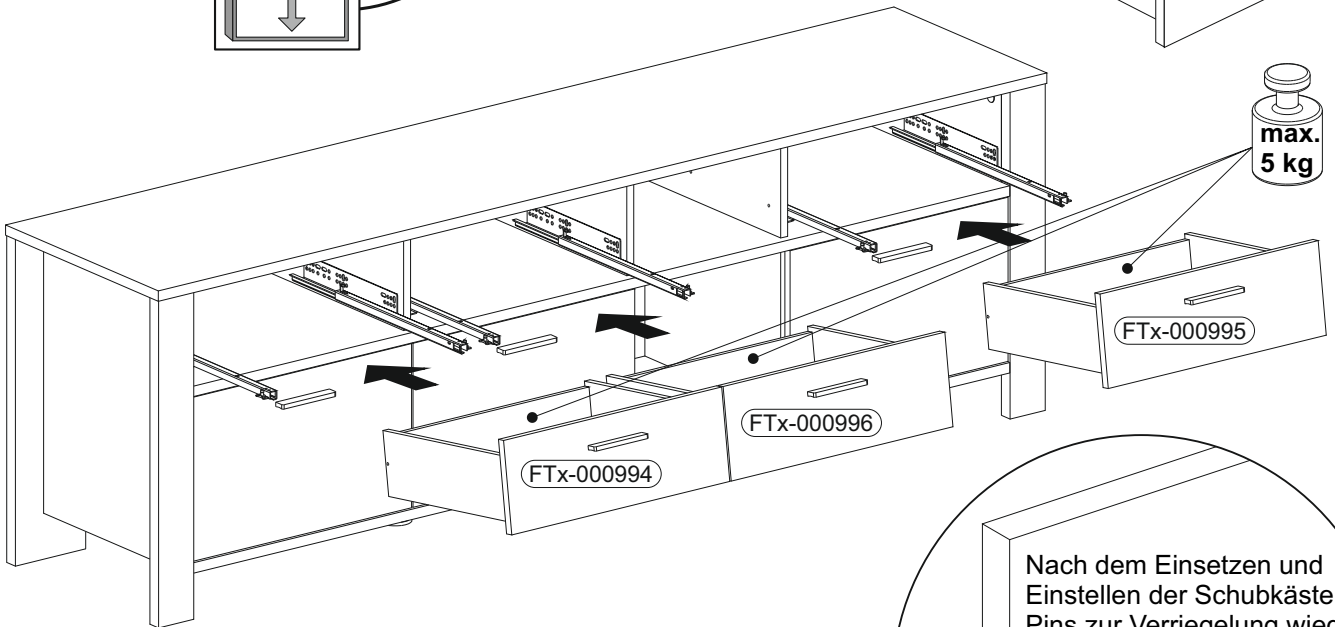
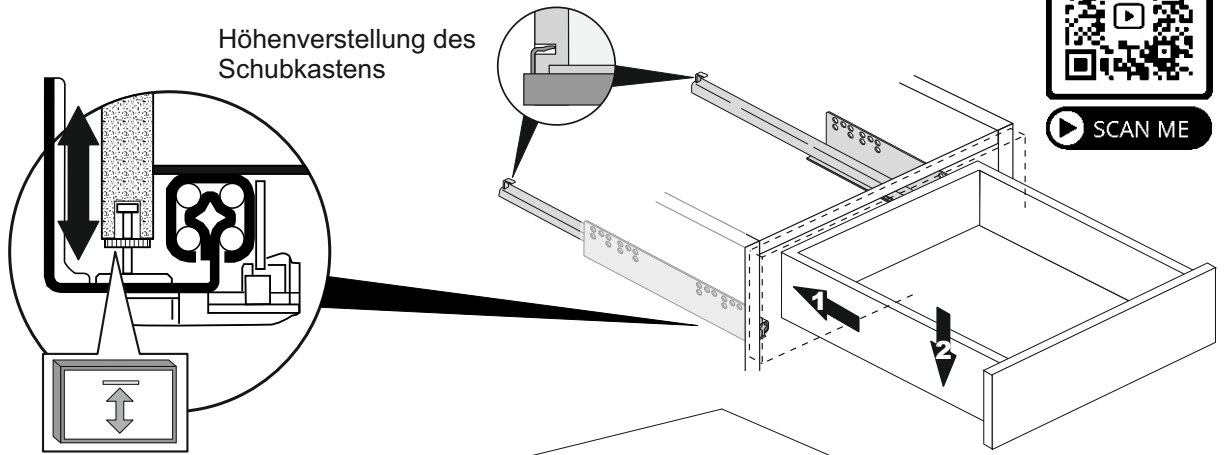

Nach dem Einsetzen und Einstellen der Schubkästen Pins zur Verriegelung wieder eindrücken!

