

Assembly instructions

Montageanleitung

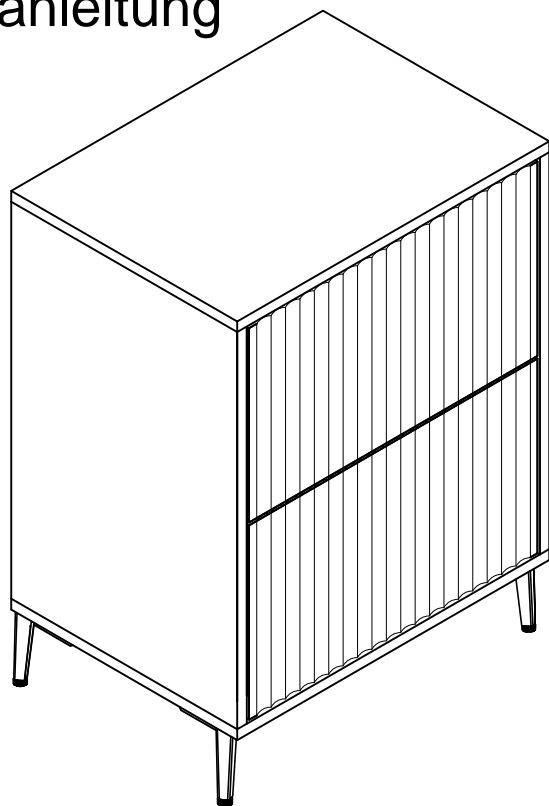

WF531182



Werkzeug Phillips-schraubendreher
tool phillips head screwdriver



Montagedauer 1 Stunde 30 Minuten
assembling time 1 hour 30 minutes

Aufmerksamkeit

- **Wichtig - Bitte lesen Sie diese Anleitung vollständig durch, bevor Sie mit der Montage beginnen.**
- **Wenn Sie Fragen zu diesem Produkt haben, wenden Sie sich bitte rechtzeitig an Ihren Lieferanten.**
- **Vergewissern Sie sich, dass alle auf der nächsten Seite aufgeführten Komponenten und Werkzeuge vorhanden sind.**
- **Entfernen Sie alle Beschläge aus den Plastikbeuteln und trennen Sie sie in ihre Gruppen.**
- **Kinder und Tiere vom Arbeitsbereich fernhalten, Kleinteile können beim Verschlucken ersticken.**
- **Teile der Montage werden mit 2 Personen einfacher.**
- **Stellen Sie sicher, dass Sie genügend Platz haben, um die Teile anzuordnen, bevor Sie beginnen.**
- **Stellen Sie sich nicht auf das Produkt und belasten Sie es nicht, da dies zu Schäden führen kann.**
- **Montieren Sie den Artikel so nah wie möglich an seiner endgültigen Position (im selben Raum).**
- **Montieren Sie das Gerät auf einer weichen, ebenen Oberfläche, um eine Beschädigung des Geräts oder Ihres Bodens zu vermeiden (verwenden Sie den geöffneten Karton des Geräts).**

.Pflege und Wartung

- . Nur mit einem feuchten Tuch und mildem Reinigungsmittel reinigen, keine Bleich- oder Scheuermittel verwenden.
- . Prüfen Sie von Zeit zu Zeit, ob die Schrauben am Produkt locker sind.

Notiz

- .Bei Bedarf kann die nächste Seite ausgeschnitten und während der gesamten Montage als Referenz verwendet werden.
- .Bewahren Sie diese Seite mit diesen Anweisungen zum späteren Nachschlagen auf.

- . **Important-** Please read these instructions completely before beginning assembly.

Attention

- .If you have any questions about this product, please contact your supplier in time.
- . Make sure you have all the components and tools listed on the next page.
- . Remove all fittings from the plastic bags and separate them into their groups.
- . Keep children and animals away from the work area, small parts can suffocate if swallowed.
- . Parts of the assembly are easier with 2 people.
- . Make sure you have enough space to arrange the pieces before you begin.
- . Do not stand on or put weight on the product as this may cause damage.
- . Assemble the item as close as possible to its final position (in the same space).
- . Mount the device on a soft, flat surface to avoid damaging the device or your floor (use the opened box of the device).

.Care and Maintenance

- . Clean only with a damp cloth and mild detergent, do not use bleach or abrasives.
- . Check from time to time whether the screws on the product are loose.

Note

- .If necessary, the next page can be cut out and used as a reference throughout the assembly.
- .Keep this page with these instructions for future reference.

DE

1. Warnhinweise für den sicheren Gebrauch

Erlauben Sie Kindern nicht, auf die Möbel zu klettern, da dies zum Umkippen und zu schweren Verletzungen führen kann.

Die maximale Tragfähigkeit jedes Regals beträgt 15 kg, die maximale Tragfähigkeit der Schublade beträgt 10 kg, bitte nicht überlasten.

2. Warnung zum Einbau

Um die Sicherheit zu gewährleisten, befolgen Sie bitte die Anweisungen zur ordnungsgemäßen Installation und bitten Sie gegebenenfalls um professionelle Hilfe.

Um ein Umkippen zu verhindern, befestigen Sie die Möbel mit den mitgelieferten Dübeln an der Wand.

3. Verwendung von Umweltwarnungen

Vermeiden Sie die Gefahr eines Brandes, indem Sie die Möbel nicht in der Nähe von Zündquellen oder heißen Gegenständen aufstellen.

Lassen Sie die Möbel nicht in einer feuchten Umgebung stehen, um Materialschäden zu vermeiden.

4. Wartungs- und Pflegehinweise

Bitte überprüfen Sie regelmäßig alle Verbindungen und Befestigungselemente, um sicherzustellen, dass sie bei Unfällen sicher sind.

Verwenden Sie für die Reinigung Ihrer Möbel empfohlene Reinigungsmittel und vermeiden Sie Reinigungsmittel mit aggressiven Chemikalien.

5. besondere Warnung

Dieses Produkt ist mit einem Kippschutz ausgestattet, der Verletzungen durch Umkippen verhindert.

FR

1. Avertissements pour une utilisation sûre

Ne permettez pas aux enfants de grimper sur les meubles, car cela pourrait les faire basculer et les blesser gravement.

La capacité de charge maximale de chaque étagère est de 15 kg, la capacité de charge maximale du tiroir est de 10 kg, veuillez ne pas les surcharger.

2. avertissement sur le montage

Pour garantir la sécurité, veuillez suivre les instructions pour une installation correcte et demander l'aide d'un professionnel si nécessaire.

Pour éviter tout basculement, fixez le meuble au mur à l'aide des fixations fournies.

3. Utilisation des avertissements environnementaux

Évitez les risques d'incendie en ne plaçant pas le meuble à proximité de sources d'inflammation ou d'objets chauds.

Ne laissez pas le meuble dans un environnement humide afin d'éviter tout dommage matériel.

4. Avertissements relatifs à la maintenance et à l'entretien

Veuillez vérifier régulièrement toutes les connexions et fixations afin de vous assurer qu'elles sont sûres en cas d'accident.

Utilisez les nettoyeurs recommandés pour nettoyer vos meubles et évitez les nettoyeurs contenant des produits chimiques agressifs.

5. avertissement spécial

Ce produit est équipé d'un dispositif anti-basculement, installé pour éviter les blessures causées par le basculement.

UK

1. Warnings for safe use

Do not allow children to climb on the furniture, as this could cause them to topple over and seriously injure themselves.

The maximum load capacity of each shelf is 15 kg, the maximum load capacity of the drawer is 10 kg. Please do not overload them.

2. warning on assembly

To ensure safety, please follow the instructions for correct installation and seek professional help if necessary.

To prevent tipping, secure the furniture to the wall using the fixings supplied.

3. Use of environmental warnings

Avoid the risk of fire by not placing furniture near sources of ignition or hot items.

Do not leave the furniture in a humid environment to prevent material damage.

4. Maintenance and care warnings

Please check all connections and fasteners regularly to ensure they are secure in case of accidents.

Use recommended cleaners to clean your furniture and avoid cleaners that contain caustic chemicals.

5. special warning

This product comes with an anti-tip device, which is installed to prevent injuries caused by tipping.

ES

1. Advertencias para un uso seguro

No permita que los niños se suban a los muebles, ya que podrían caerse y lesionarse gravemente.

La capacidad de carga máxima de cada estante es de 15 kg, la capacidad de carga máxima del cajón es de 10 kg. Por favor, no los sobrecargue.

2. Advertencia de instalación

Para garantizar la seguridad, siga las instrucciones para una correcta instalación y solicite ayuda profesional si es necesario.

Para evitar que vuelque, fije el mueble a la pared con las fijaciones suministradas.

3. Uso de advertencias medioambientales

Evite el riesgo de incendio no colocando el mueble cerca de fuentes de ignición u objetos calientes.

No deje el mueble en un ambiente húmedo para evitar daños materiales.

4. Advertencias de mantenimiento y cuidado

Compruebe periódicamente todas las conexiones y fijaciones para asegurarse de que estén bien sujetas en caso de accidente.

Utilice limpiadores recomendados para limpiar sus muebles y evite los que contengan productos químicos agresivos.

5. advertencia especial

Este producto viene con un dispositivo antivuelco, que se instala para evitar lesiones causadas por vuelcos.

IT

1. Avvertenze per un uso sicuro

Non permettete ai bambini di arrampicarsi sui mobili, perché potrebbero cadere e ferirsi gravemente.

La portata massima di ogni ripiano è di 15 kg, quella del cassetto di 10 kg. Si prega di non sovraccaricarli.

2. Avvertenza sull'installazione

Per garantire la sicurezza, seguire le istruzioni per una corretta installazione e, se necessario, richiedere l'assistenza di un professionista.

Per evitare il ribaltamento, fissare il mobile alla parete utilizzando i fissaggi in dotazione.

3. Uso delle avvertenze ambientali

Evitare il rischio di incendio non collocando i mobili in prossimità di fonti di accensione o di oggetti caldi.

Non lasciare i mobili in un ambiente umido per evitare danni materiali.

4. Avvertenze per la manutenzione e la cura

Controllare regolarmente tutti i collegamenti e gli elementi di fissaggio per assicurarsi che siano sicuri in caso di incidenti.

Per la pulizia dei mobili utilizzate i detersivi consigliati ed evitate quelli che contengono sostanze chimiche aggressive.

5. Avviso speciale

Questo prodotto è dotato di un dispositivo antiribaltamento, installato per prevenire le lesioni causate dal ribaltamento.

WF531182

① X4

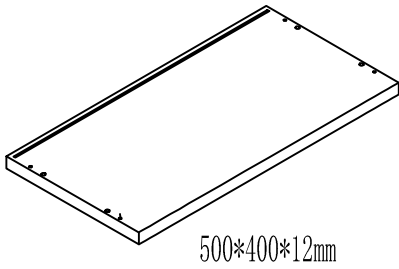

② X4

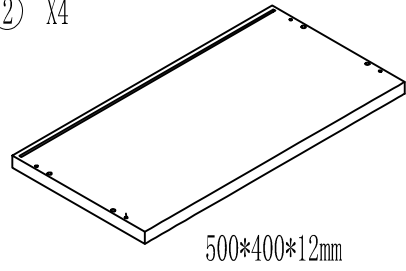

③ X4

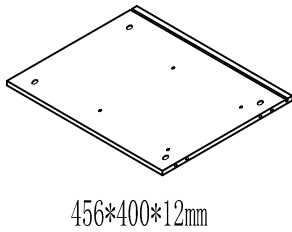

④ X4

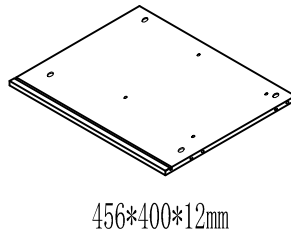

⑤ X4

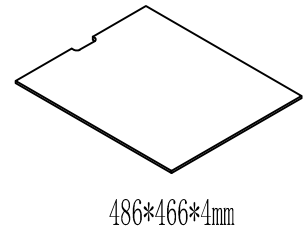

⑥ X8

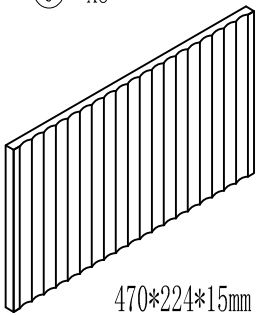

⑦ X8

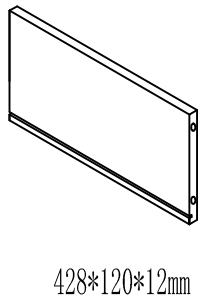

⑧ X8

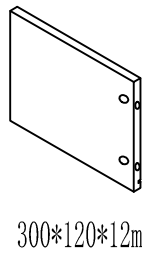

⑨ X8

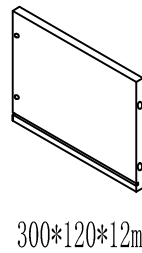

⑩ X8

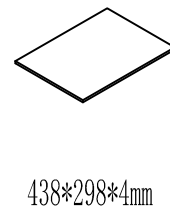

⑪ X8

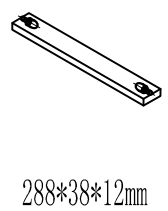

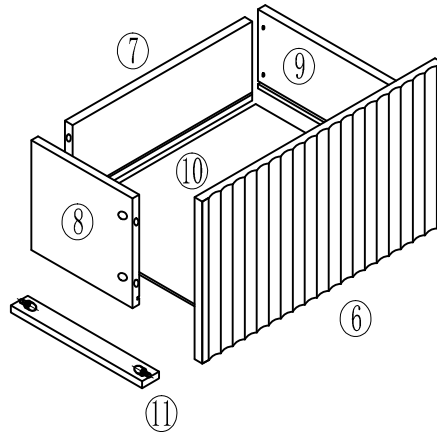
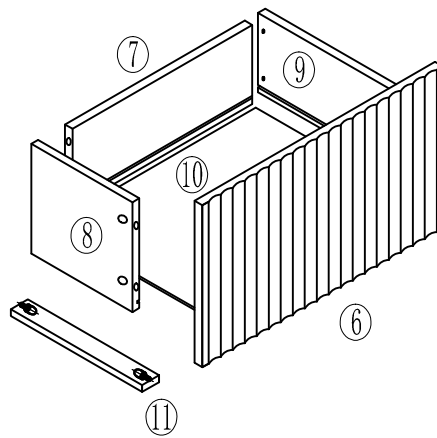
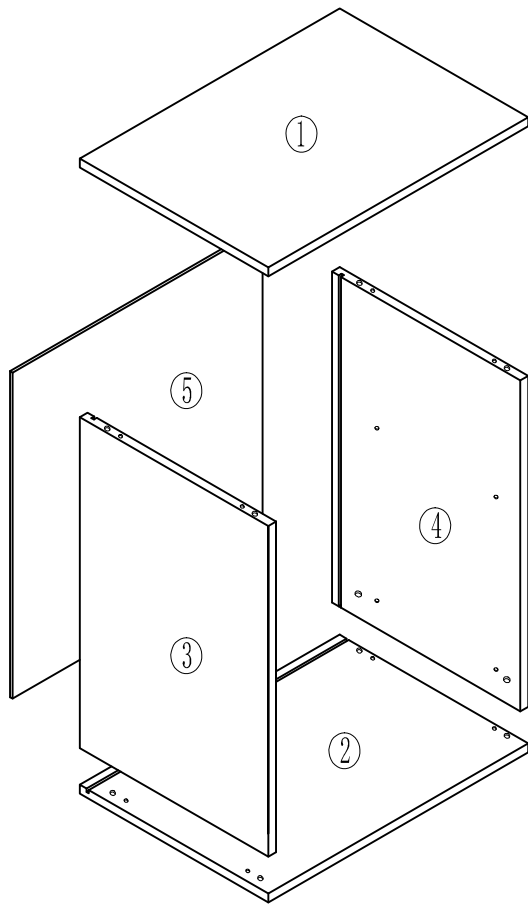

A	B	C	D	E	G	H	I	J	O	CL	CR	DL	DR
48 PCS	48 PCS	16 PCS	4 PCS	8 PCS	80 PCS	8 PCS	2 SETS	2 SETS	8 PCS	4 PCS	4 PCS	4 PCS	4 PCS



A	B	C	D	E	G	H	I	J	O	CL	CR	DL	DR
48 PCS	48 PCS	16 PCS	4 PCS	8 PCS	80 PCS ø3.5*12	8 PCS	2 SETS	2 SETS	8 PCS ø4*32 ø4*25	4 PCS	4 PCS	4 PCS	4 PCS

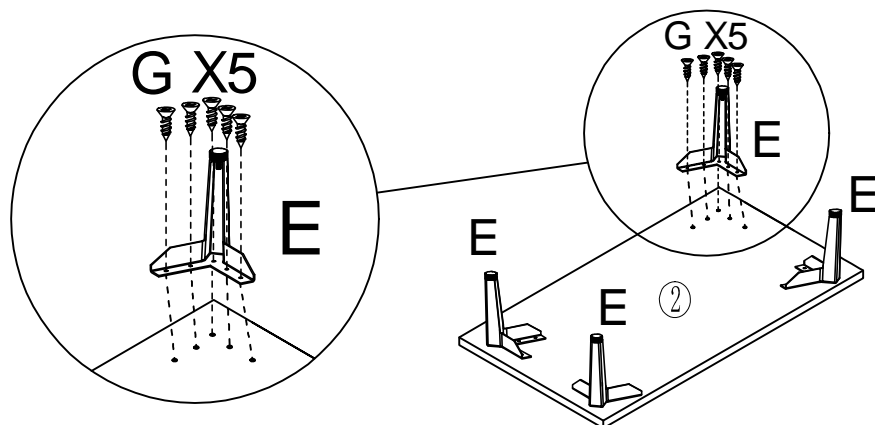

STEP 1

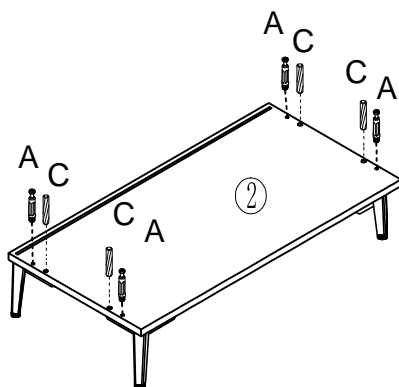

 E 4 PCS	 G 20 PCS
---	--

STEP 2



 A 4 PCS	 C 4 PCS
---	---

STEP 3

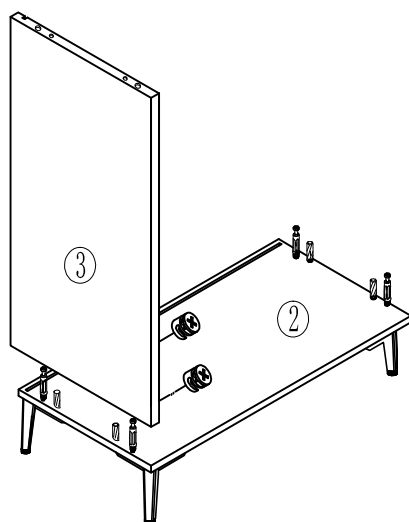

 B 2 PCS

STEP 4

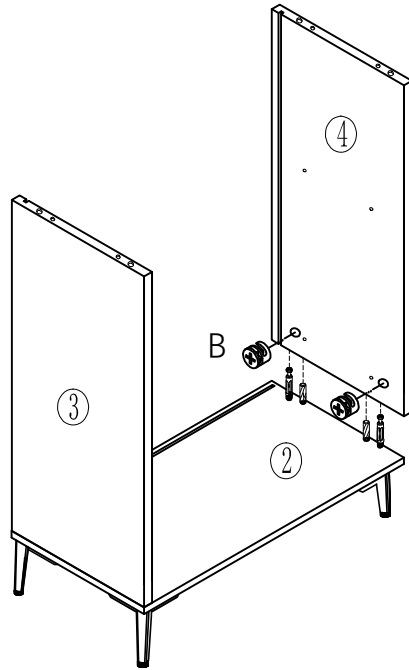

B
2 PCS

STEP 5

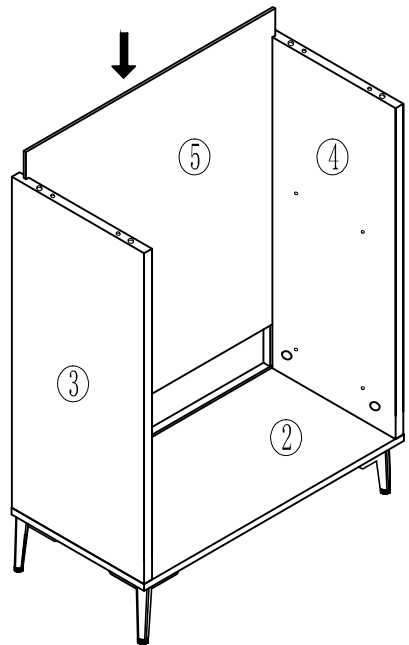



STEP 6

G	CL	G
8 PCS	2 PCS	2 PCS

G	CR	G
8 PCS	2 PCS	2 PCS

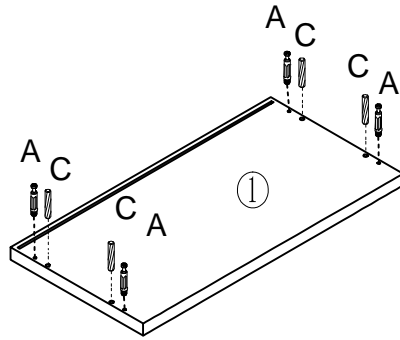
STEP 7



A	C
	
4 PCS	4 PCS

STEP 8

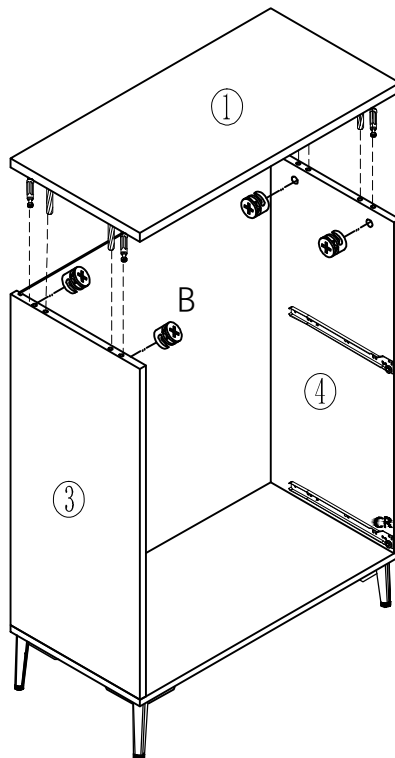

B

4 PCS

STEP 9

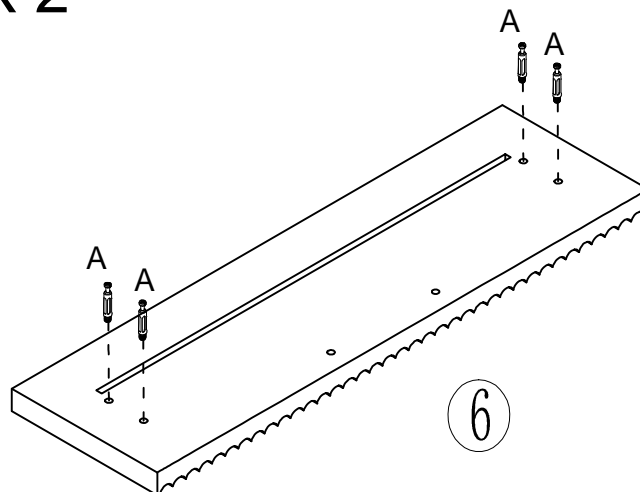
X 2





A

8 PCS

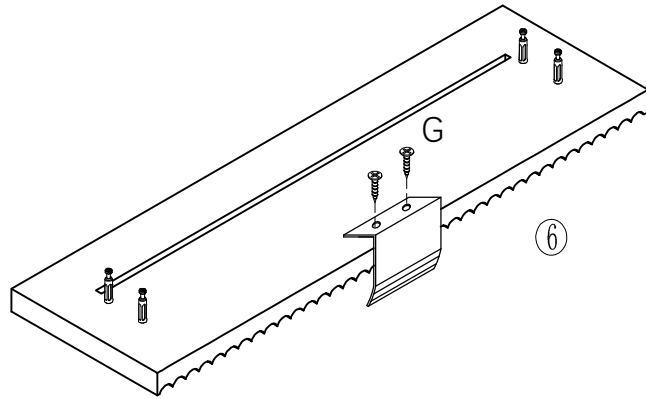
STEP 10

X 2



D	G
	
2 PCS	4 PCS φ3.5*12

STEP 11

X 2

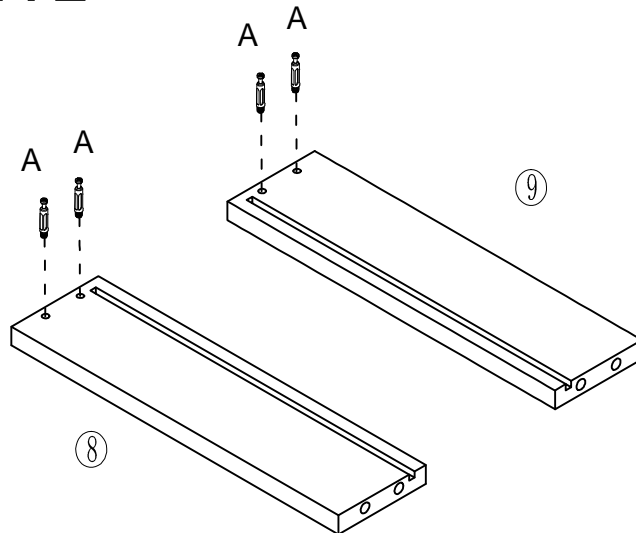

A

8 PCS

STEP 12

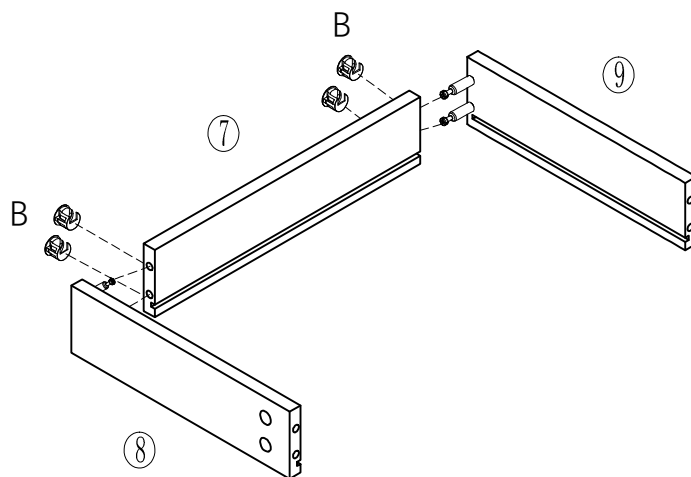
X 2



B

8 PCS

STEP 13

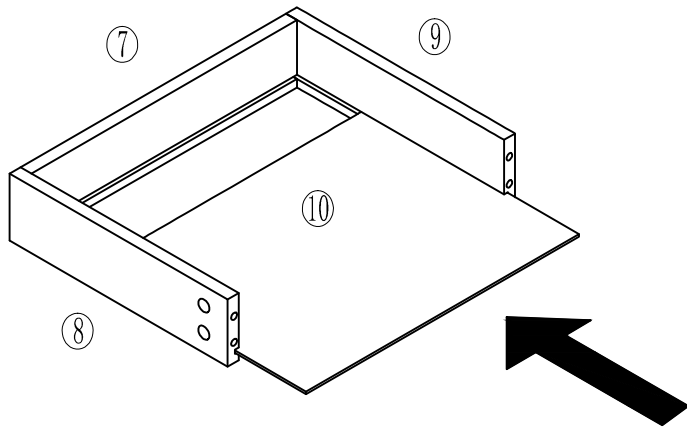
X 2



STEP 14

X 2

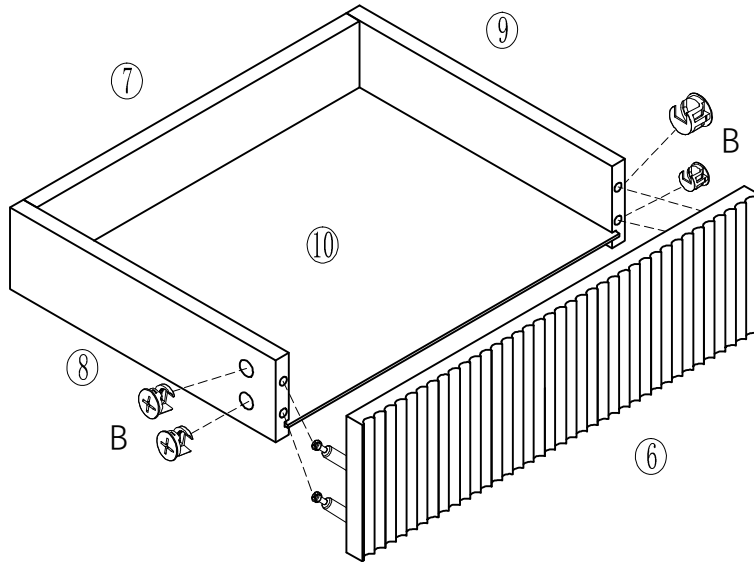



B

8 PCS

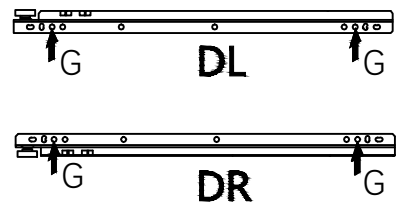
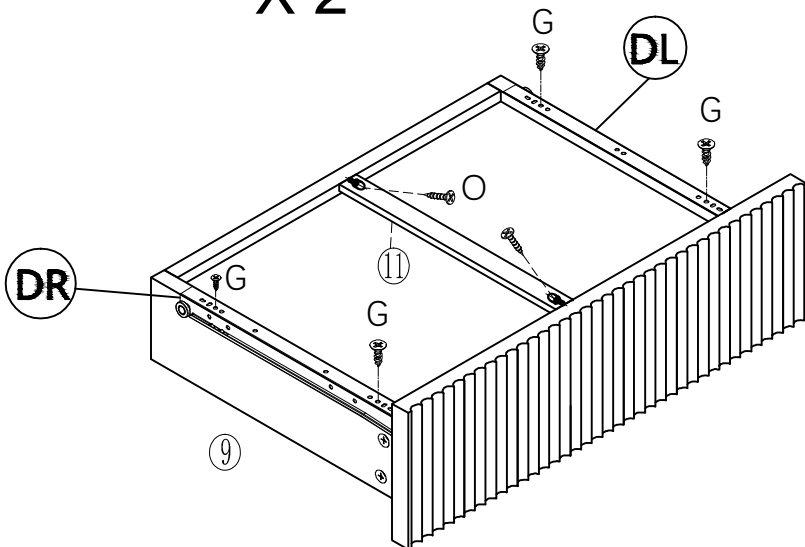
STEP 15

X 2

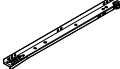



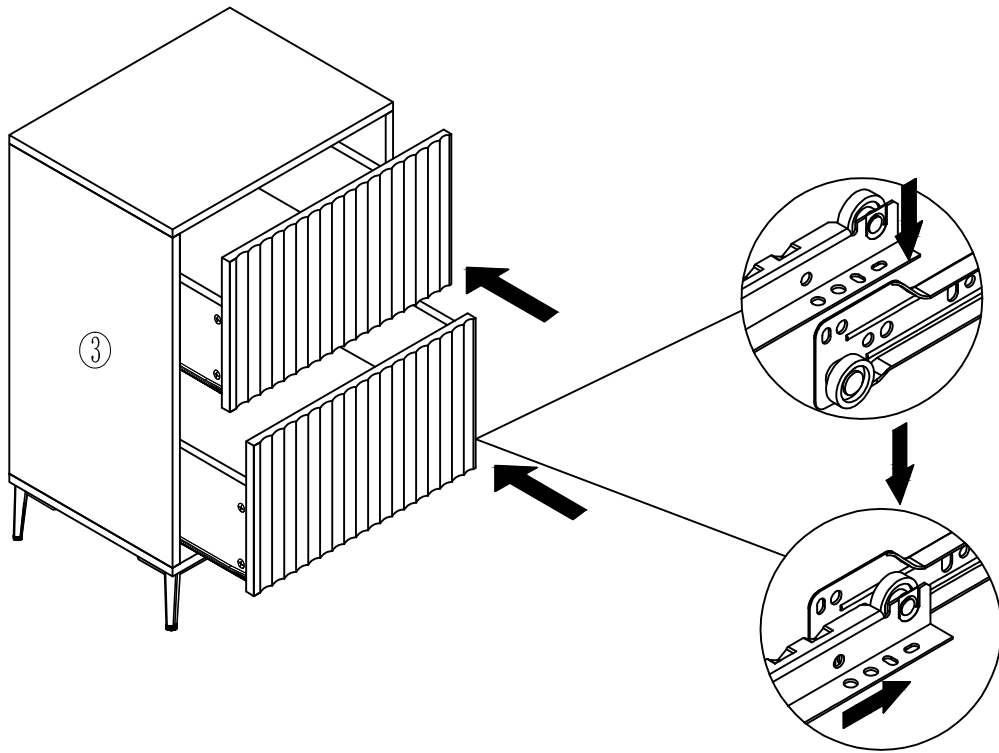

G	O	DL	DR
			
8 PCS	4 PCS	2 PCS	2 PCS

STEP 16

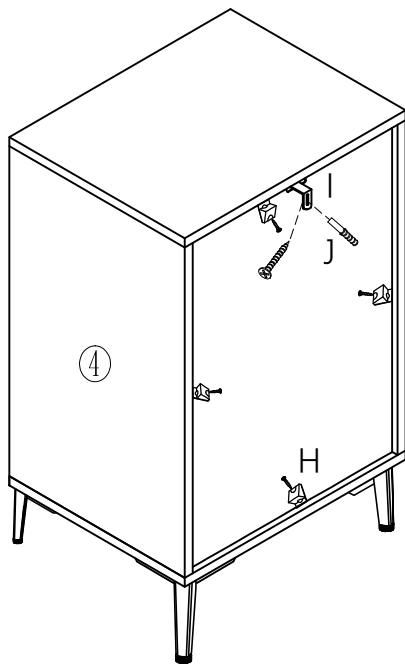

STEP 17



 H	 I	 J
4 PCS	1 SETS	1 SETS