

# ASSEMBLY INSTRUCTION

Item Number : WF297721AAAW

WF297722AAAW

Upholstered Bed:140\*200CM

## TIPS



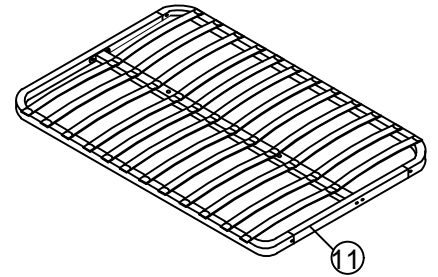
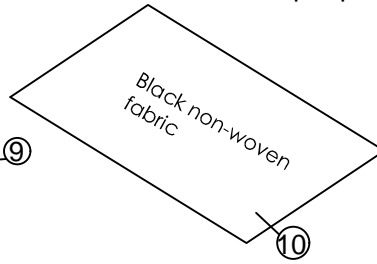
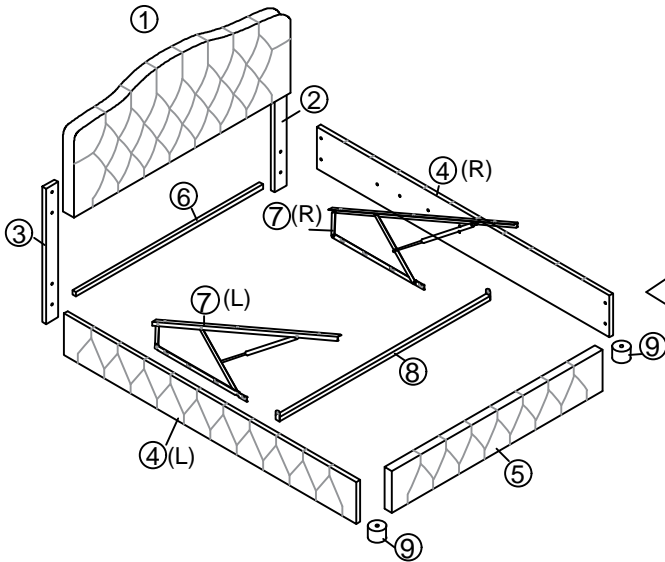
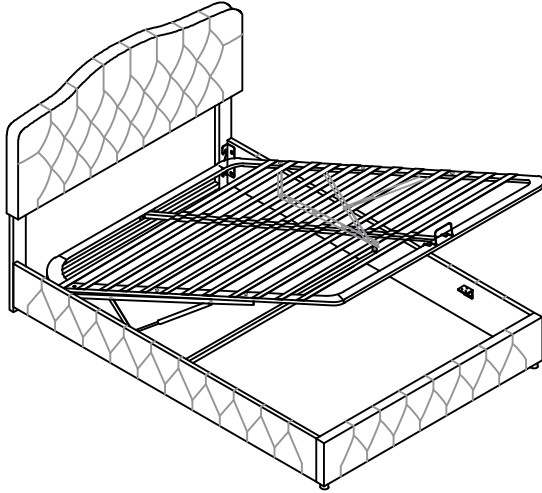

1. This set comes in 2 boxes. If you don't receive a full 2 boxes, please contact our customer service.
2. Please read the instructions fully before assembly. These instructions include important information which could ensure correct assembly. We have been working on providing high quality products for you. However, in the rare instance that your product is defective, missing parts or there are some issues, please don't hesitate to contact our customer service to submit parts requirements, assembly suggestion, or warranty claims, and we will give the best solution as soon as possible. If necessary, we need you to provide some more clear pictures of the issue.
3. Insert the screws in holes and tighten the screws, but not too tight, 70%~80% is ok, finally tighten all the screws. If some issues happened that some screws can not target to the hole or some parts are difficult to install, please adjust the tightness of the screws.
4. 2 people are recommended to finish.

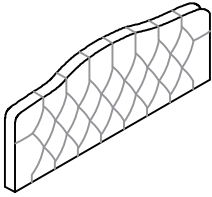

Parts List			Hardware List		
NO	ITEM	QTY	NO	ITEM	QTY
1	Head board	1	A	Allen Key	1
2	Head board leg	1	B	Bolts (M8x45mm)	20
3	Head board leg	1	C	Washer	4
4	Side rails	2	D	Bolts (M8x18mm)	22
5	Foot board	1	E	Nuts	14
6	Head board cross bar	1	F	Nails (M4x25mm)	9
7	Gas lift	2	G	Nails (M4x50mm)	2
8	Cross bar	1	H	Nuts	2
9	Legs	2	I	Bolts (M6x25mm)	10
10	Non woven fabric	1	J	Spanner	1
11	Slat frame	1	K	Hinge	4
			L	Plastic support	3
			M	Middle legs	2
			N	Middle slats cap	12
			O	End slats cap	24
			P	Stopper	1
			Q	Three hole iron	2

# Part List

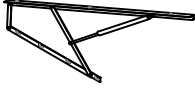
WF297721AAW

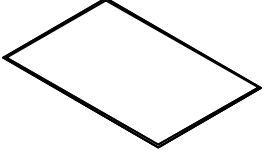
<p><b>1</b></p>  <p>Head board-1pc</p>	<p><b>2</b></p>  <p>Head board legs-1pc</p>	<p><b>3</b></p>  <p>Head board legs-1pc</p>
<p><b>7</b></p>  <p>Gas lift-2pcs</p>	<p><b>9</b></p>  <p>Legs -2pcs</p>	<p><b>10</b></p>  <p>Non woven fabric-1pc</p>

# Hardware List+WF297722AAW

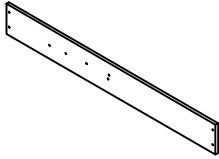
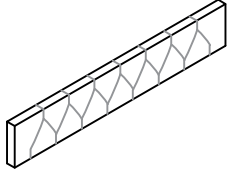
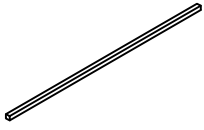
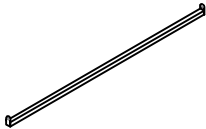
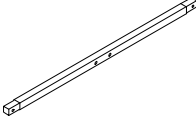
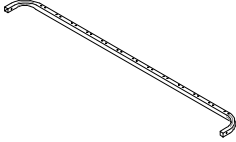
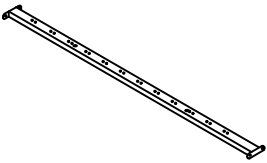
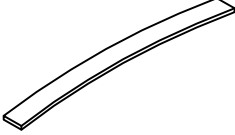

<p><b>4</b></p>  <p>Side rails -2pcs</p>	<p><b>5</b></p>  <p>Foot board -1pc</p>	<p><b>6</b></p>  <p>Storage box board -1pc</p>
<p><b>8</b></p>  <p>Cross bar -1pc</p>	<p><b>11.1</b></p>  <p>Metal frame cross bar-2pcs</p>	<p><b>11.2</b></p>  <p>Metal frame side bar-2pcs</p>
<p><b>11.3</b></p>  <p>Metal frame middle bar-1pc</p>	<p><b>11.4</b></p>  <p>Slat-24pcs</p>	

Attention: Do not tighten the screws before completing the entire installation. If you have any difficulty with the installation process, please feel free to contact us.

### Step 1x2

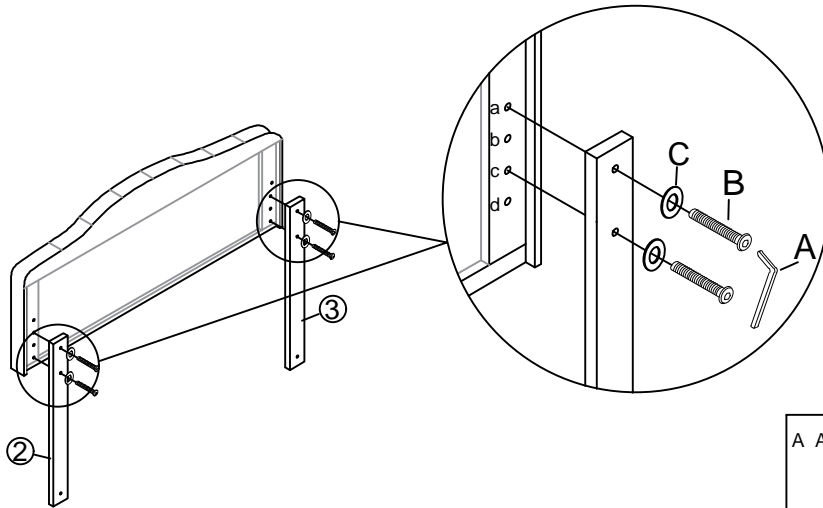
Fix the Headboard legs ②/③ To the headboard ① With Bolts B and Washers C by using Allen key A, you can chose the holes a and c or b and d .





A Allen Key x1 	C Washer x 4 	B Bolts x 4  M8X45mm
---	---	---

### Step 2x2

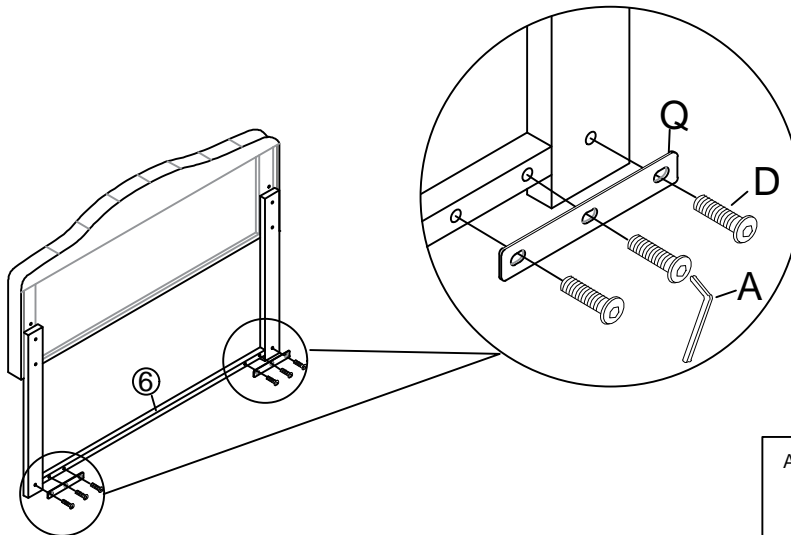
Fix the Headboard cross bar ⑥ to the Headboard legs ②/③ with Bolt D and Three hole iron Q by using Allen key A.





A Allen Key 	D Bolts x 6  M8X18mm	Q Three hole iron x2 
--	---	---

### Step 3

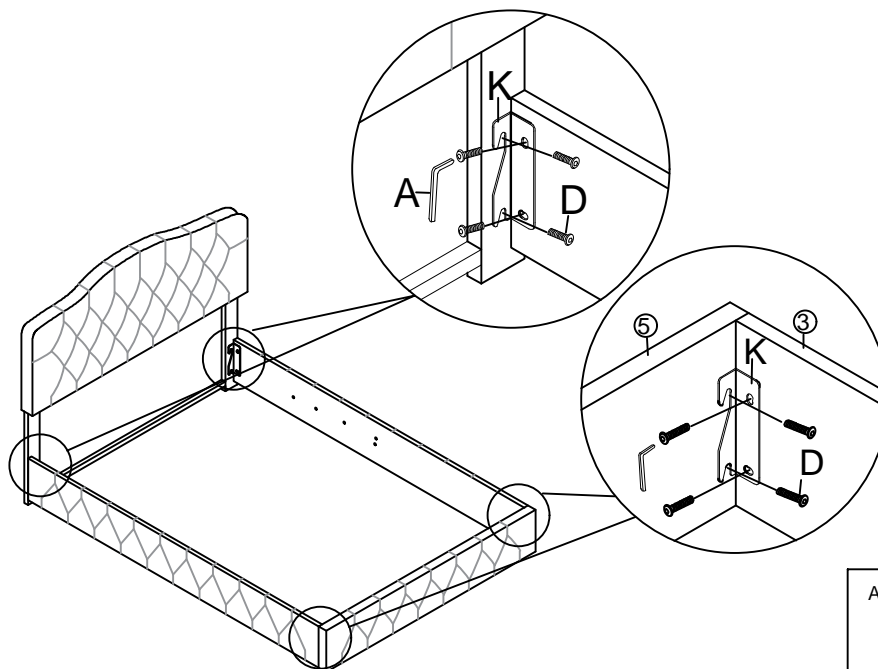
Fix the side rails ④ to the side head board legs ② and ③, footboard ⑤ with Bolts D and hinges K by using Allen key A





A Allen Key 	D Bolts x 16  M8X18mm	K Hinge x4 
--	--	---

## Step 4

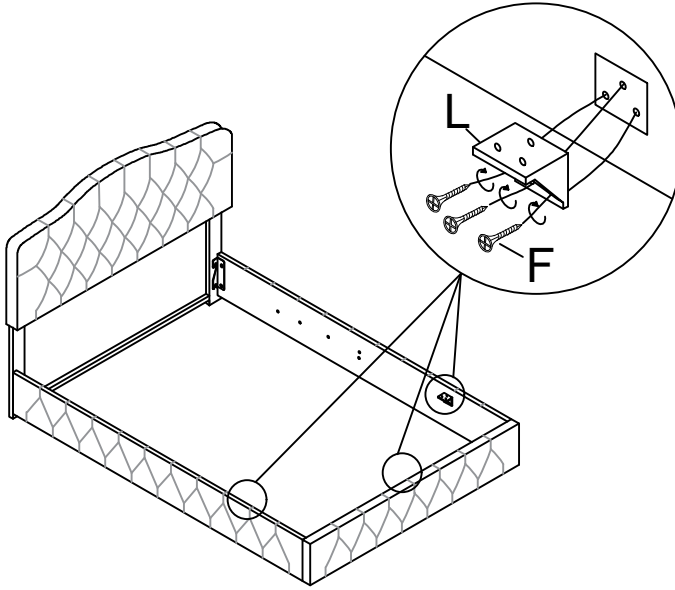
Fix the plastic support L to the side rails ④ and footboard ⑤ with nails F by using electric drill or screw driver



F Nails x9  M4X25mm	L Plastic support x3 
--	---

## Step 5

Fix the cross bar ⑧ to the side rails ④ with bolts I by using electric drill or screw driver.

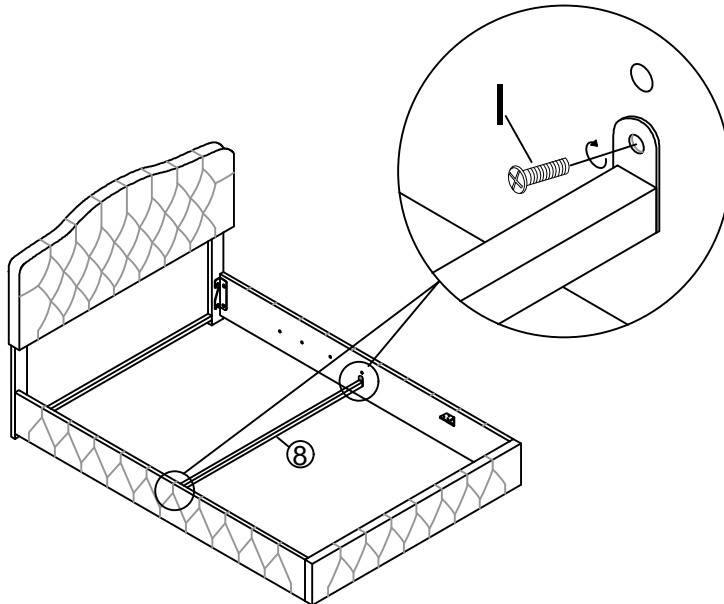



I Bolts x 2  M6X25mm
---

## Step 6 x2

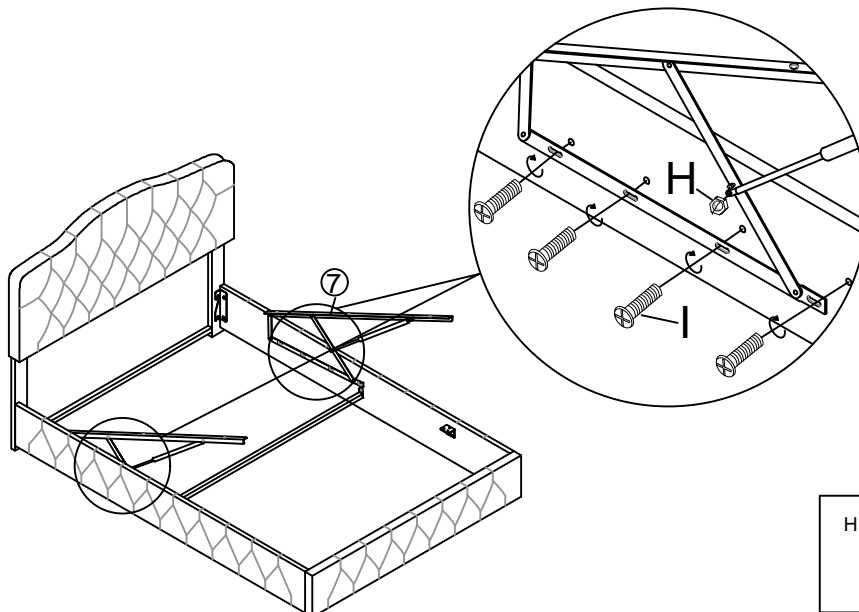
Fix the gas lifts ⑦ to the side rails ④ with bolts I by using electric drill. fix the gas bar to the gas lifts ⑦ with nuts H.



H Nuts x2 	I Bolts x 8  M6X25mm
--	---

## Step 7

Stick the black non-woven fabric ⑩ To the bottom of bed

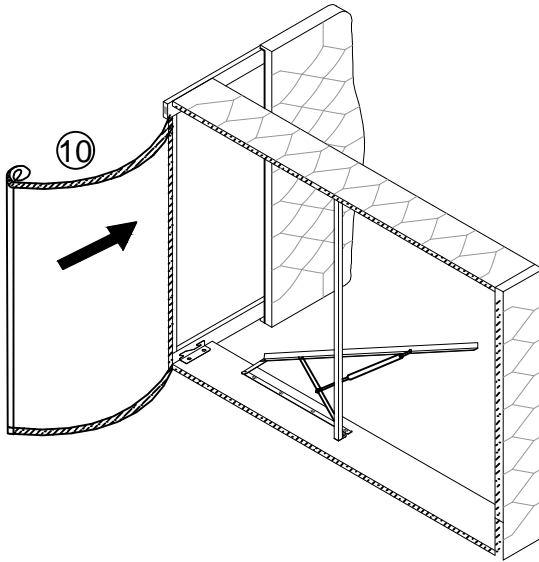

## Step 8

Fix the legs ⑨ to the footboard ⑤ with nails G by using electric drill or screw driver

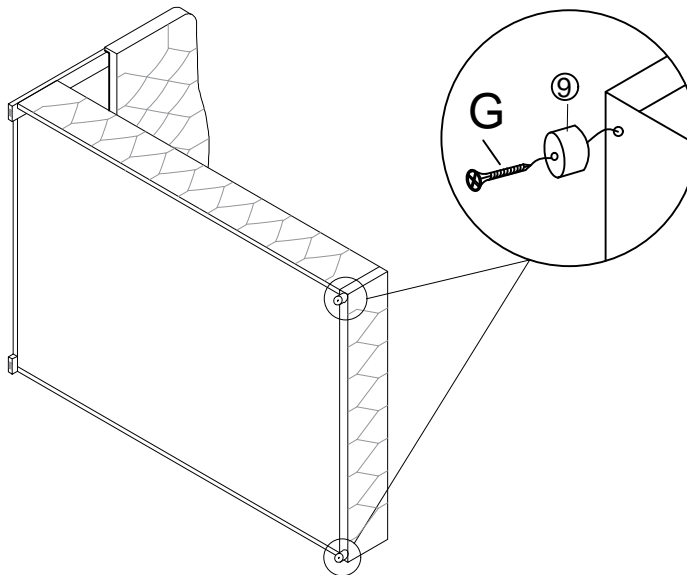

G Nails x2



M4X50mm

## Step 9

Assemble the slats frame with bolts B and nuts E by using Spanner J

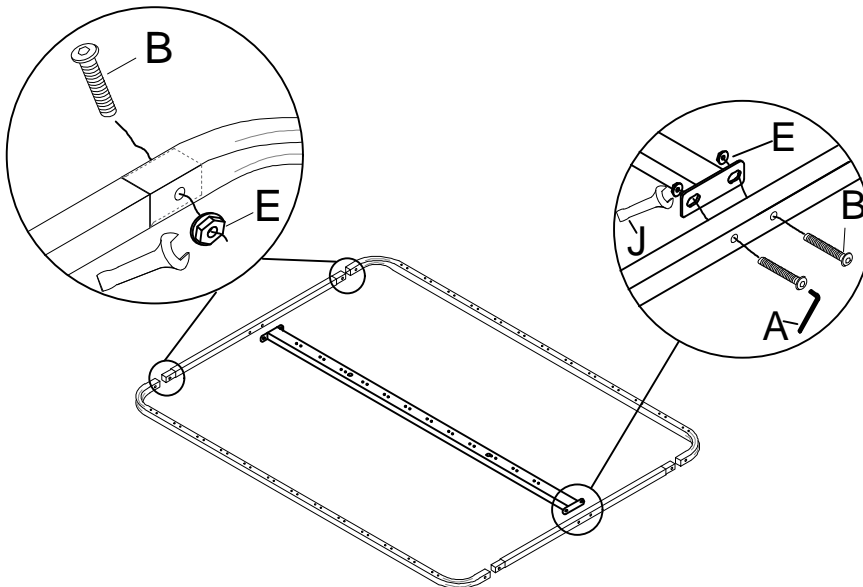

B Bolts x8



M8X45mm

E Nuts x8







J Spanner x1

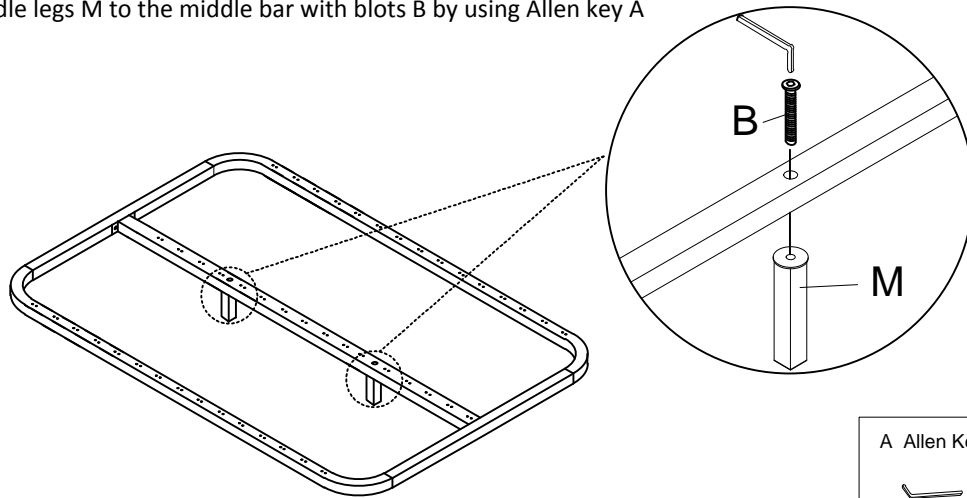

## Step 10 x2

Fix middle legs M to the middle bar with bolts B by using Allen key A





A Allen Key 	B Bolts x 2  M8X45mm	M Middle legs x2 
--	---	---

## Step 11

Assemble the slats into the assembled slats frame with middle slats cap N and end slats cap O

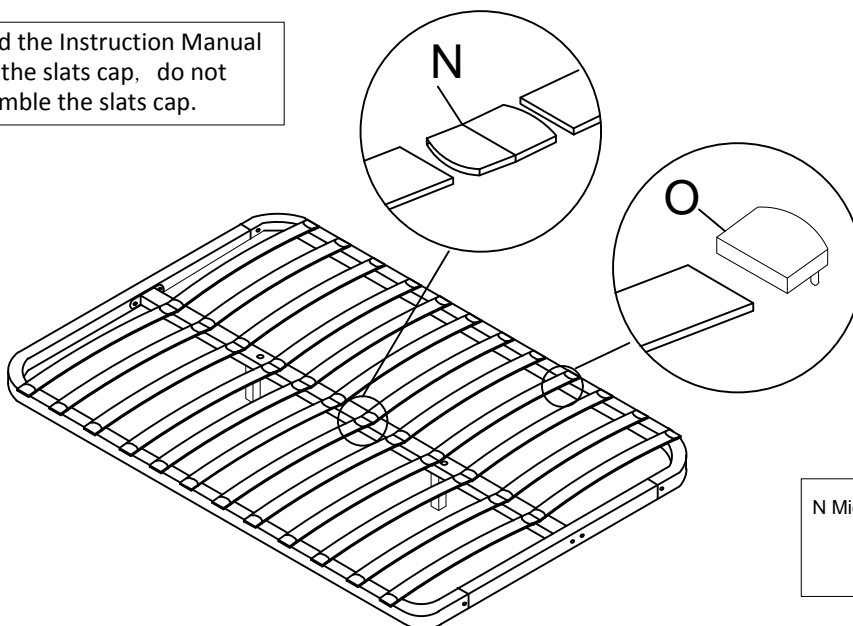
Note: Please read the Instruction Manual before installing the slats cap, do not violently disassemble the slats cap.





N Middle slats x12 	O End slats cap x24 
---	--

## Step 12

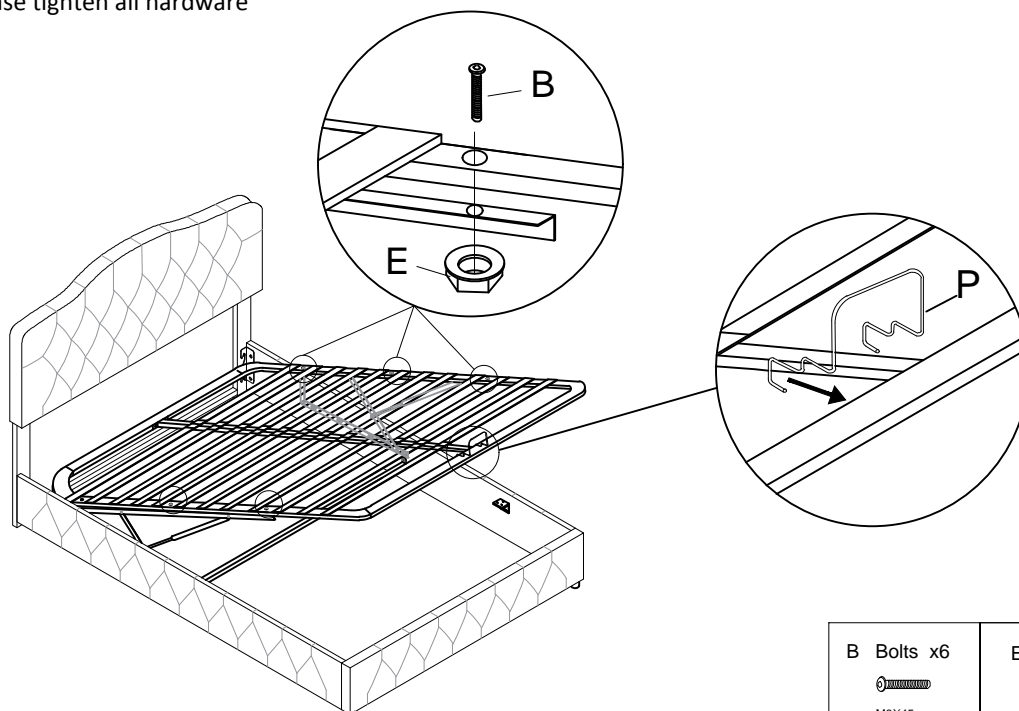
Assemble the slats frame ⑪ to the gas lifts ⑦ with bolts B and nuts E, put the stopper P in the end of the slat frame, then assemble is finished, now please tighten all hardware



B Bolts x6  M8X45mm	E Nuts x6 	P Stopper x1 
--	--	---