

(D) *Montageanleitung*

(NL) *Handleiding voor de montage*

(TR) *Montaj talimatı*

(FR) *Notice de montage*

(CZ) *Montážní návod*

(HU) *Szerelési útmutató*

(GB) *Assembly instructions*

(PL) *Instrukcja montażu*

(RU) *Инструкция по монтажу*

(IT) *Istruzioni di montaggio*

(SK) *Návod na montáž*

(RO) *Instrucțiuni de montaj*









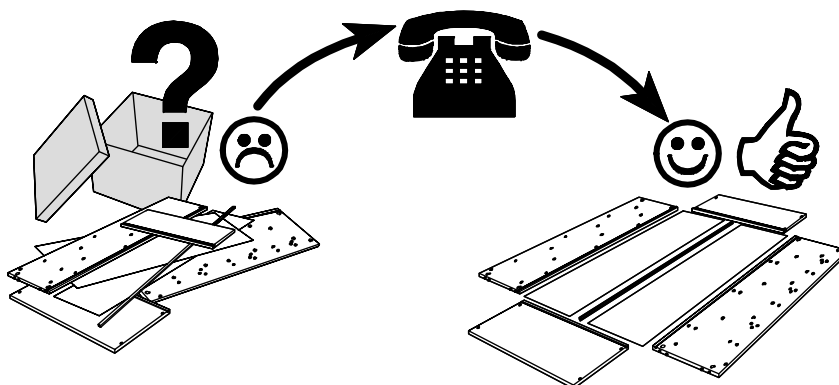
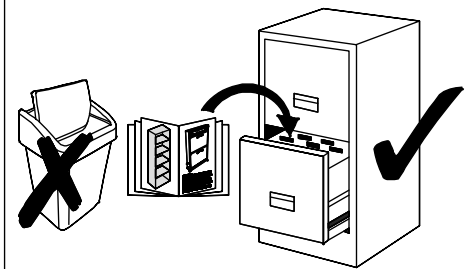

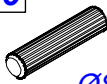

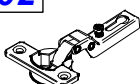
Service • Dienstverlening • Serwis • Servis • Сервисная служба • Assistenza • Szerviz

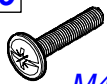
Name • Nom • Nome • Naam • Nazwa • Иméно •
Názov • Név • Denumire • Isim • Название

Nr. • No. • N° • Номер • Č • Sz

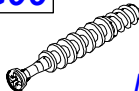
Typ • Type • Tip • Tipus • Тiпо • Тип



A10 22 x  Ø8 x 35	B06 2 x  Ø6,3 x 12	B52 12 x  Ø7 x 50	C02 4 x  fk.9	C20 4 x  2 mm	D06 2 x  M4 x 20
E17 8 x  Ø3,5 x 15	F04 1 x  4 mm	F08 1 x  45 x 20 x 16	G02 20 x  Ø15 x 11	G06 20 x  L - 34	I01 50 x  Ø1,2 x 20
K01 1 x  20 x 20 x 16 / 6,5	N01 24 x  Ø5 / Ø5	P23 2 x  Ø30x21			

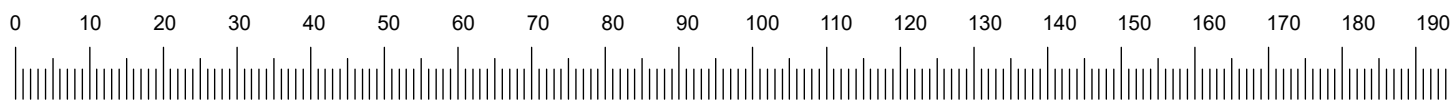
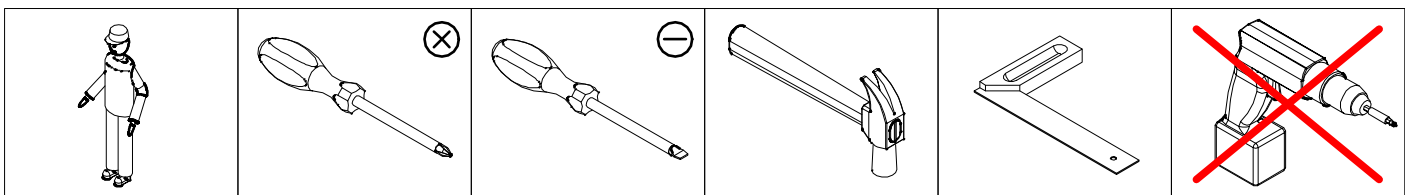

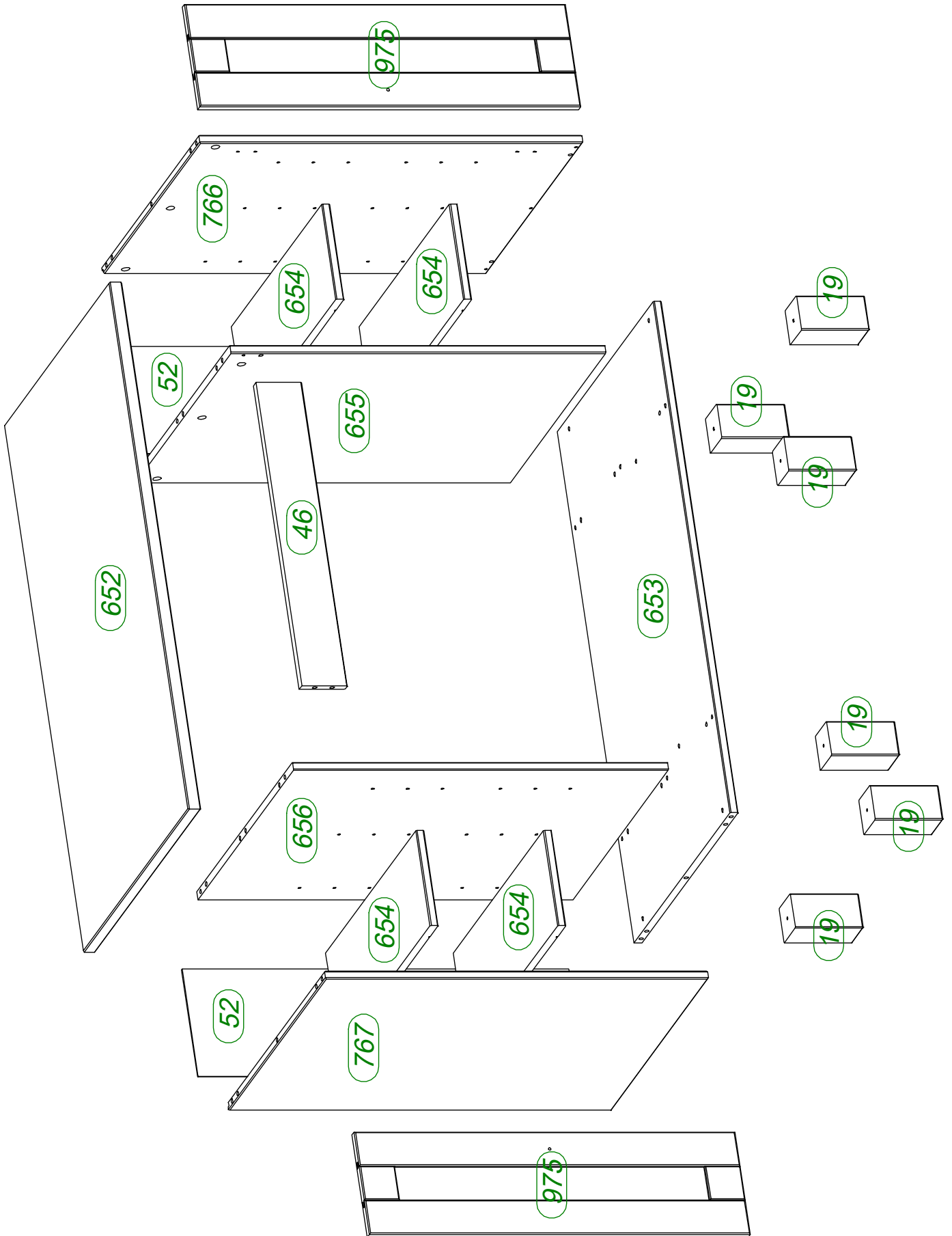



Achtung • Attention • Attenzione • Opgelet • Uwaga • Pozor • Figyelem • Atenție •
Dikkat • Внимание

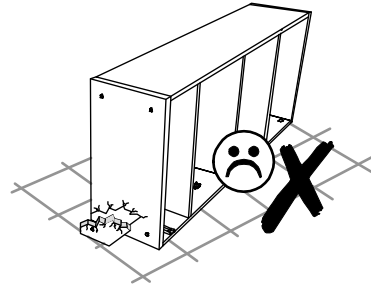
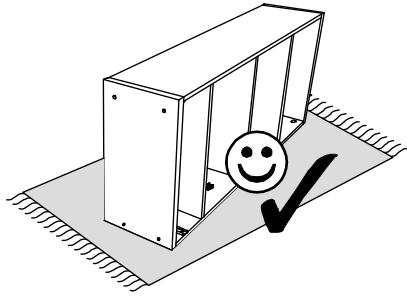

A10	16 x	C20	4 x	G06	8 x
Ø8 x 35		2 mm		L - 34	

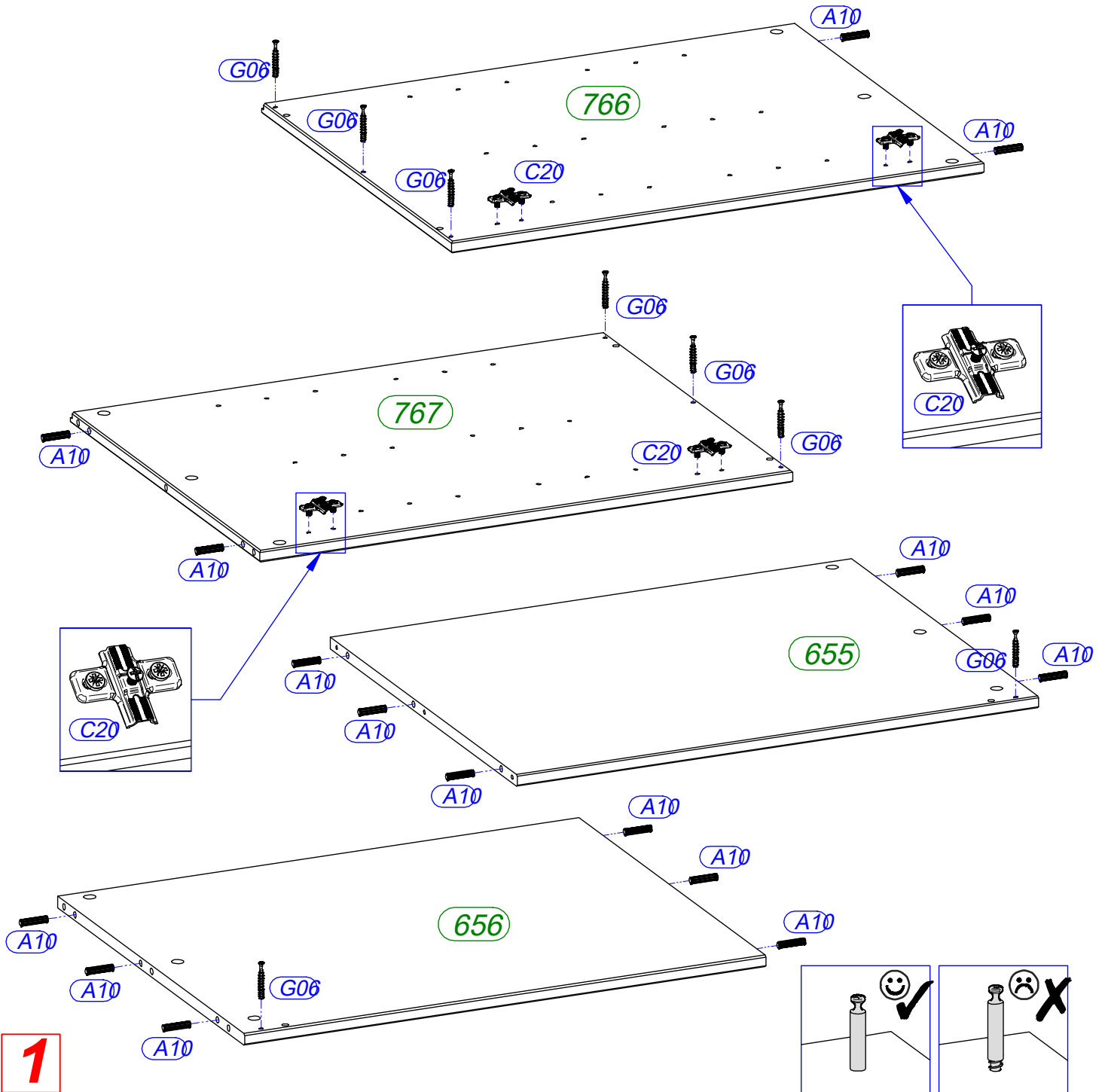

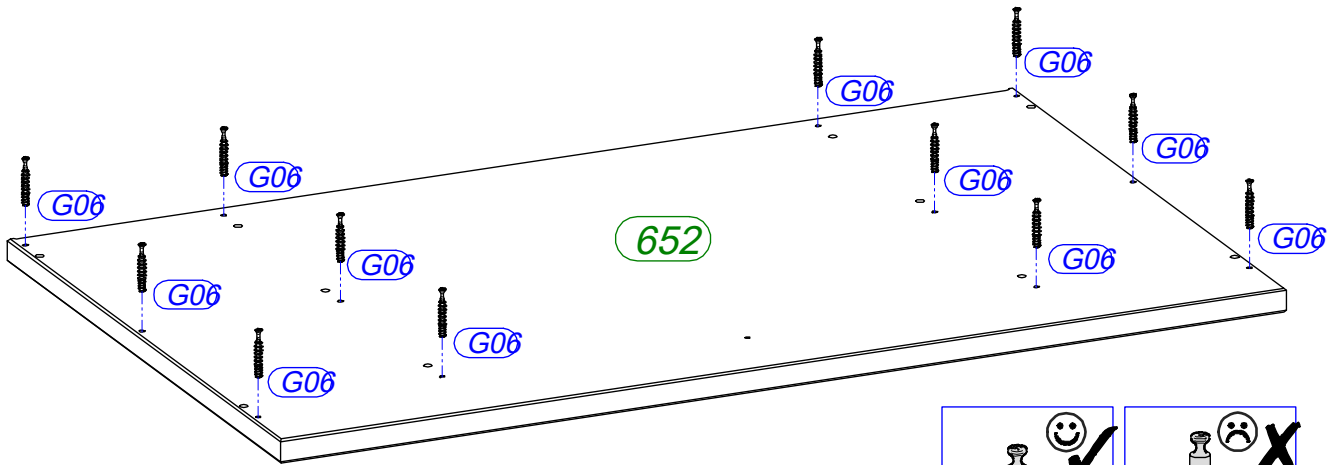
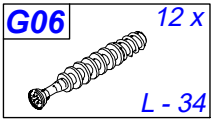

2

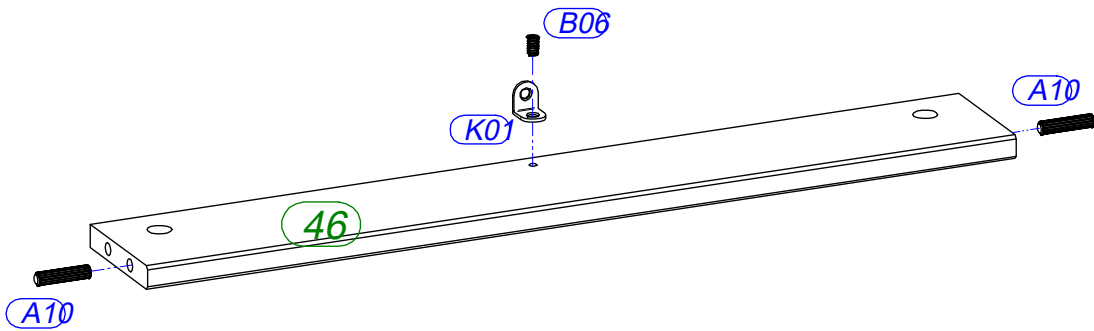
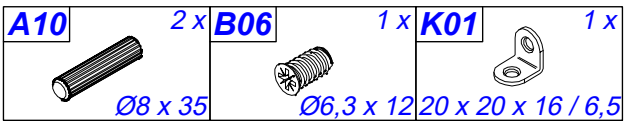
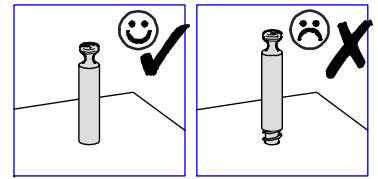

3

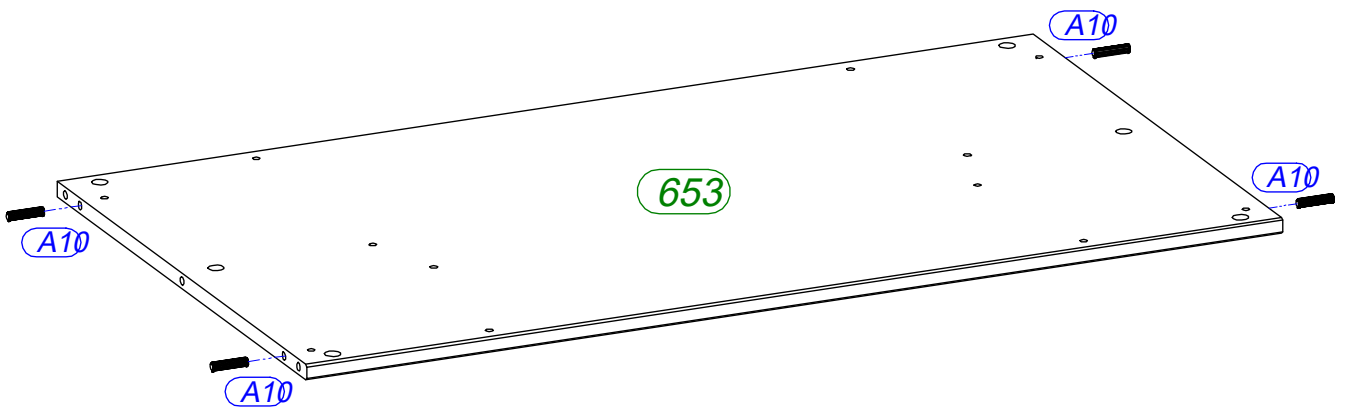
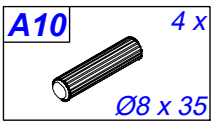

4

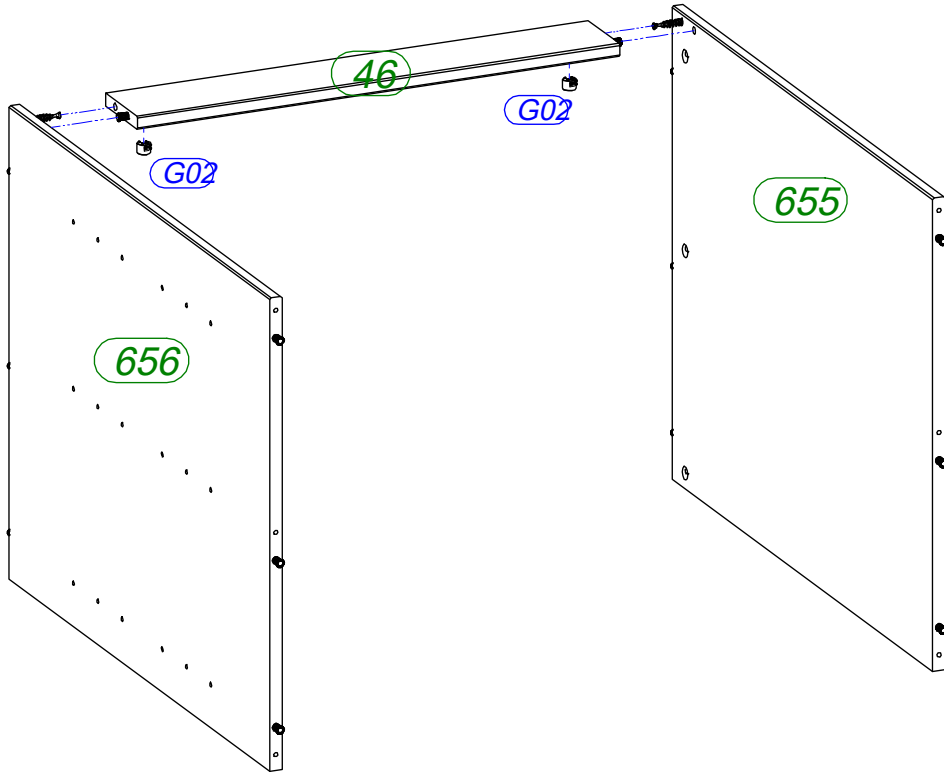
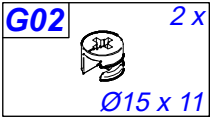

5

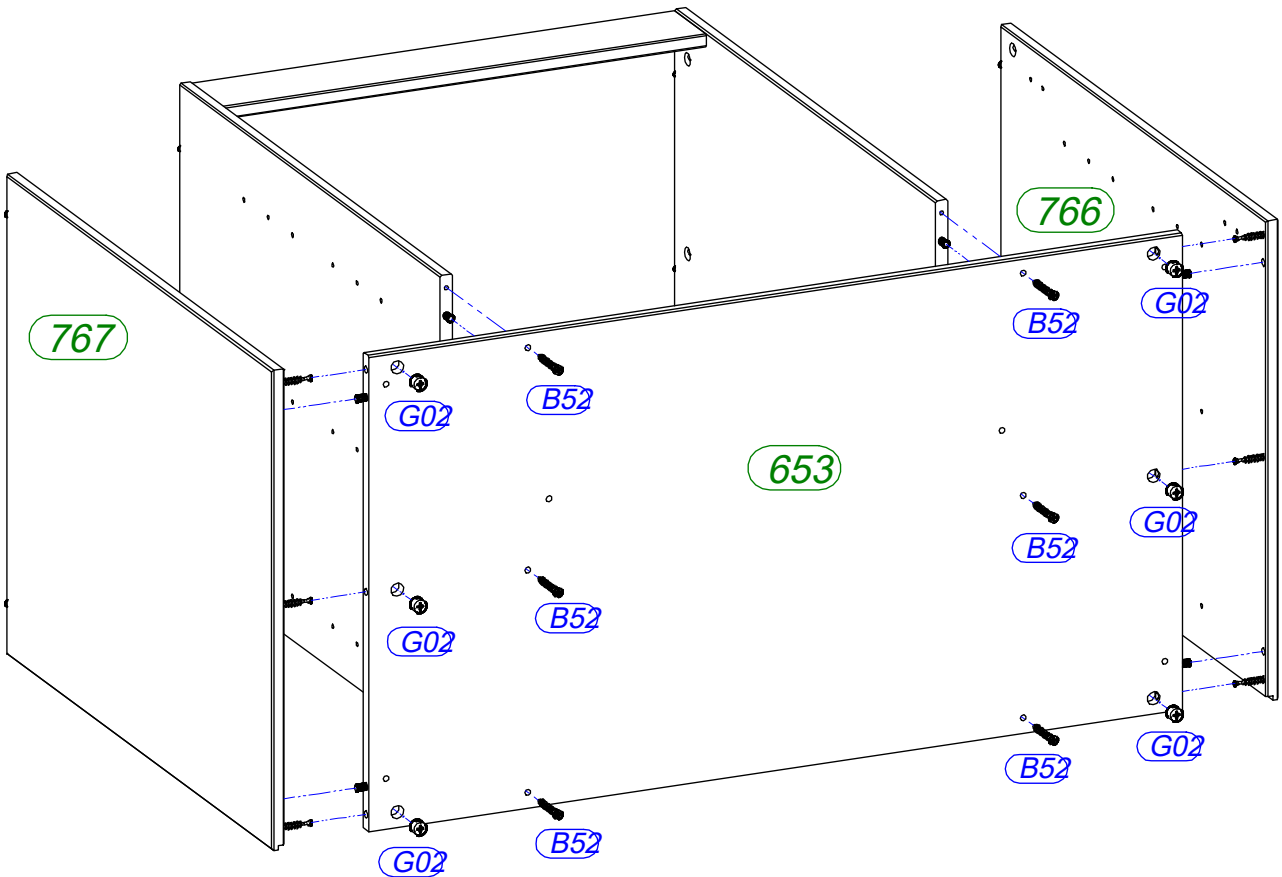
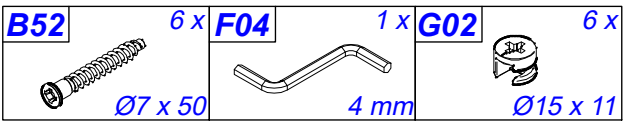



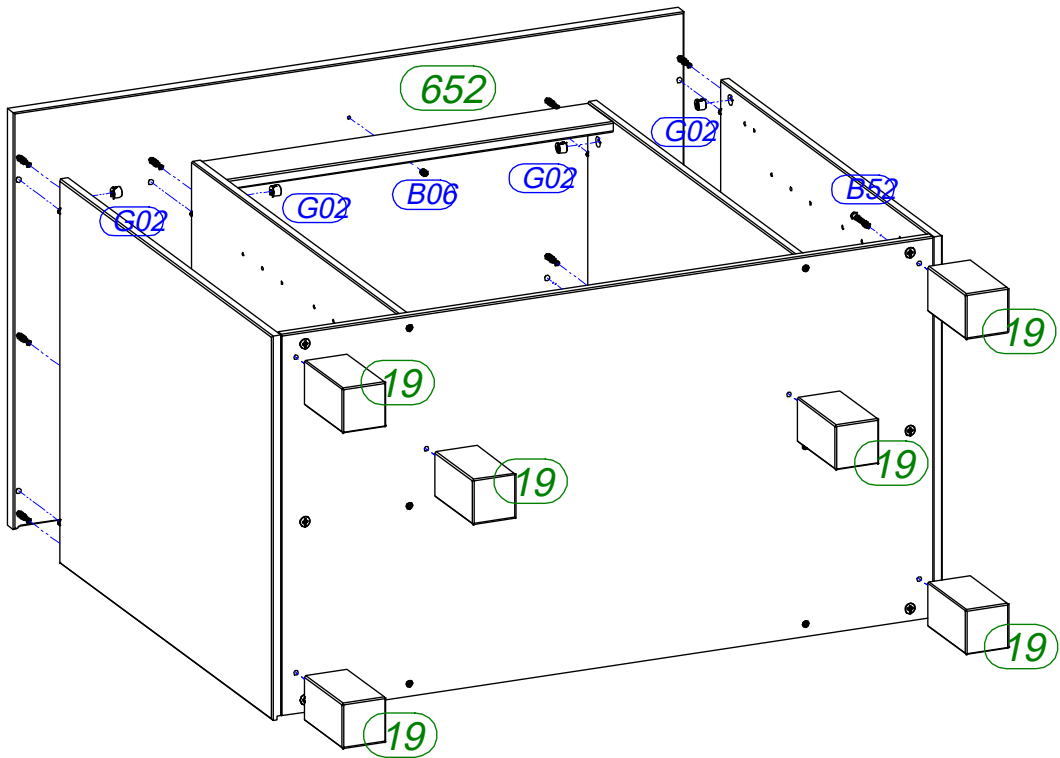
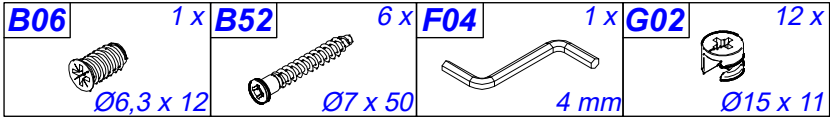

6

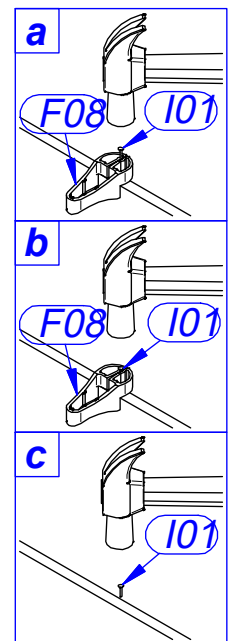
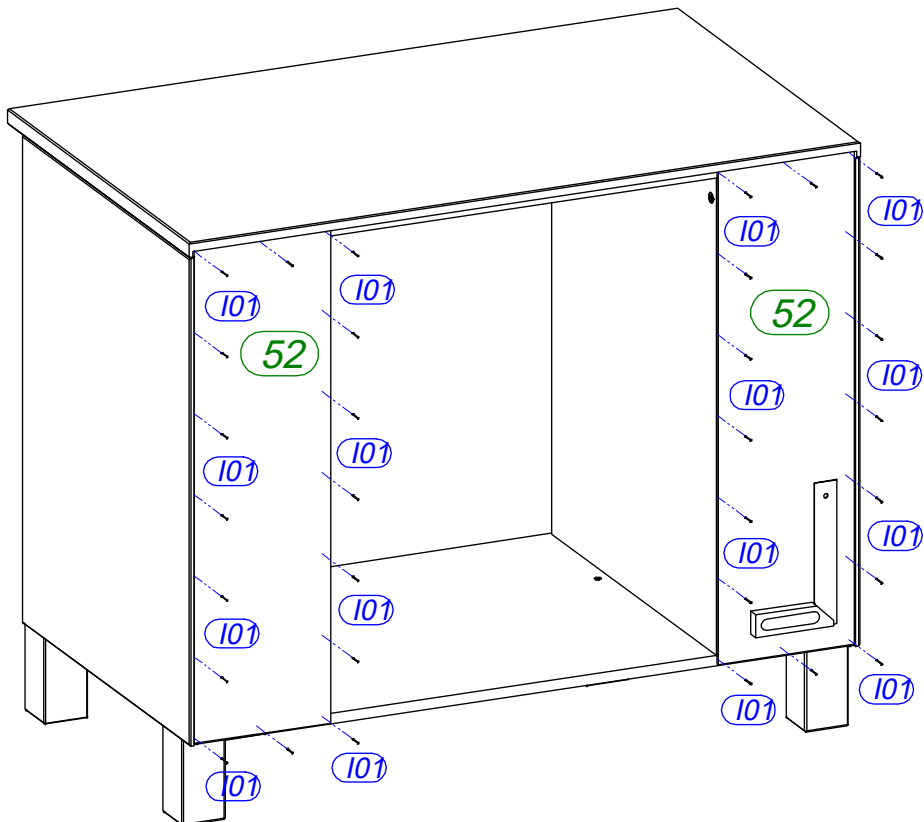
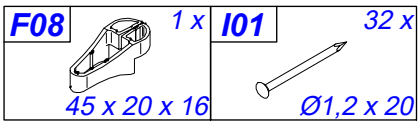

7

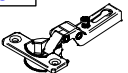

8

C02	4 x	D06	2 x	E17	8 x	P23	2 x
	fk.9		M4 x 20		Ø3,5 x 15		Ø30x21

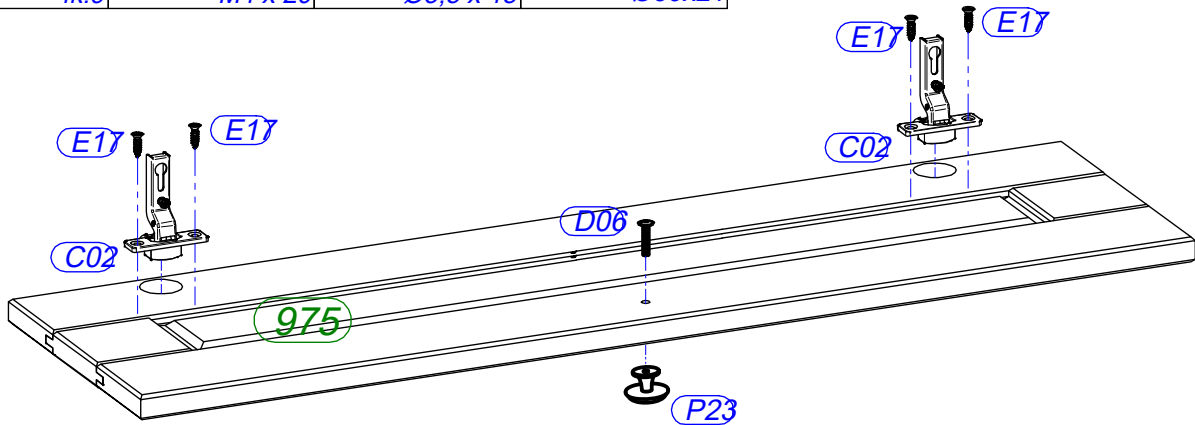

9x 2

N01	24 x
	Ø5 / Ø5

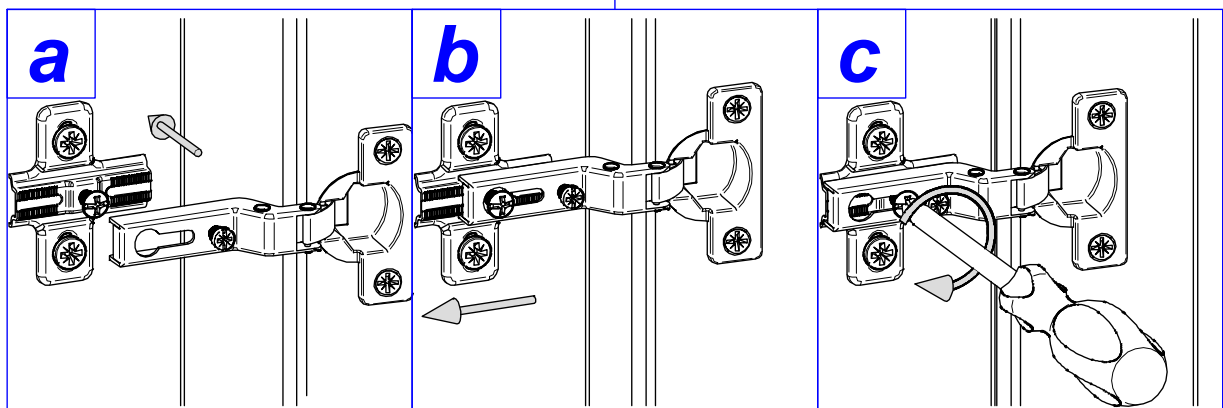
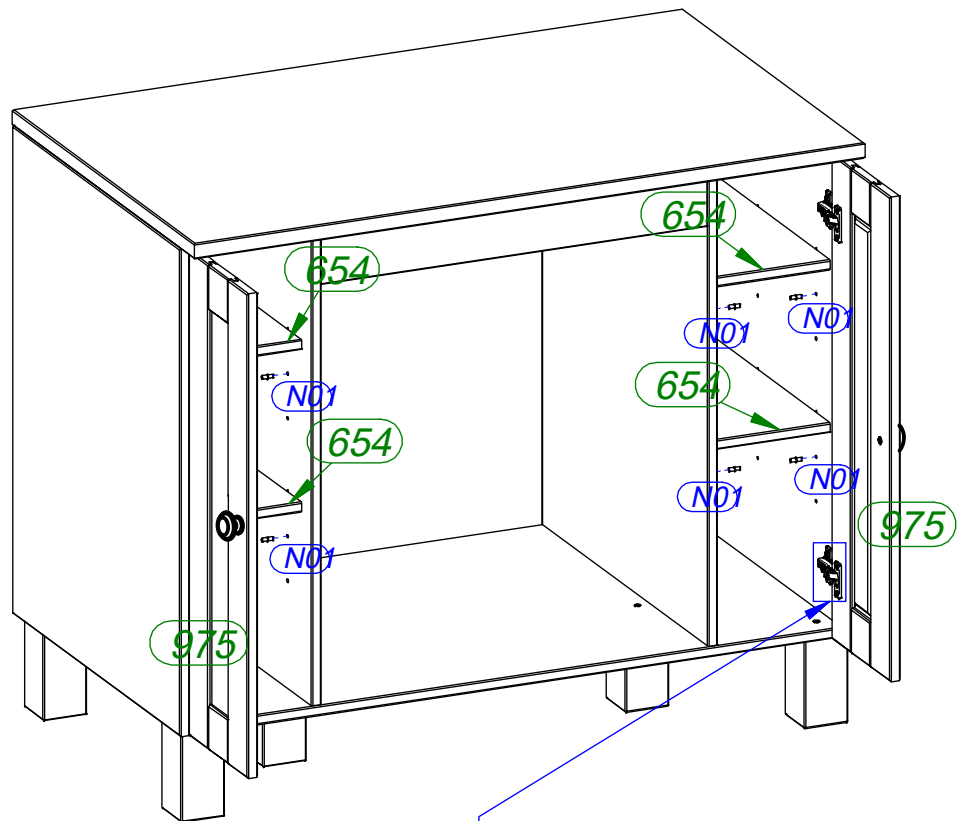

10



**Achtung • Attention • Attenzione • Opgelet • Uwaga • Pozor • Figyelem • Atenție •
Dikkat • Внимание**



(D)	Türen einstellen (Scharniere justieren)
(GB)	Adjusting the doors (adjusting the hinges)
(NL)	Deuren instellen (scharnieren afstellen)
(PL)	Nastawić drzwi (wyrównać zawiasy)
(TR)	Kapıların ayarlanması (menteşelerin seviye ayarı)
(RU)	Регулировка дверей (регулировка шарнира)
(FR)	Régler les portes (ajuster les charnières)
(IT)	Sistemare le porte (regolare le cerniere)
(CZ)	Vyrovnejte dvířka (seřďte závěsy)
(SK)	Nastavenie dverí (nastavenie závesov)
(HU)	Állítsa be az ajtókat (állítsa be a zsanérokat)
(RO)	Reglare ușii (ajustare balamale)

