

ASSEMBLY INSTRUCTIONS
MONTAGEANLEITUNGEN
N620P189271/N620P189272

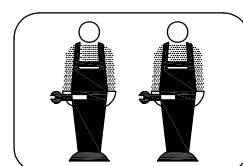

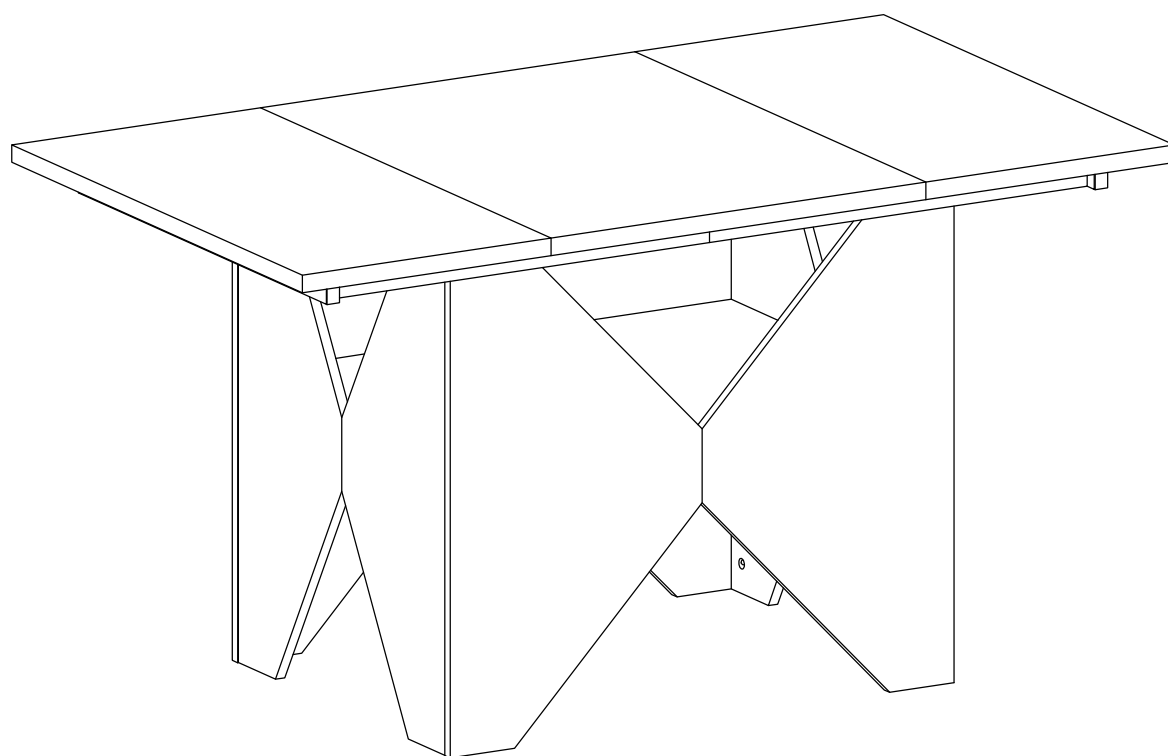



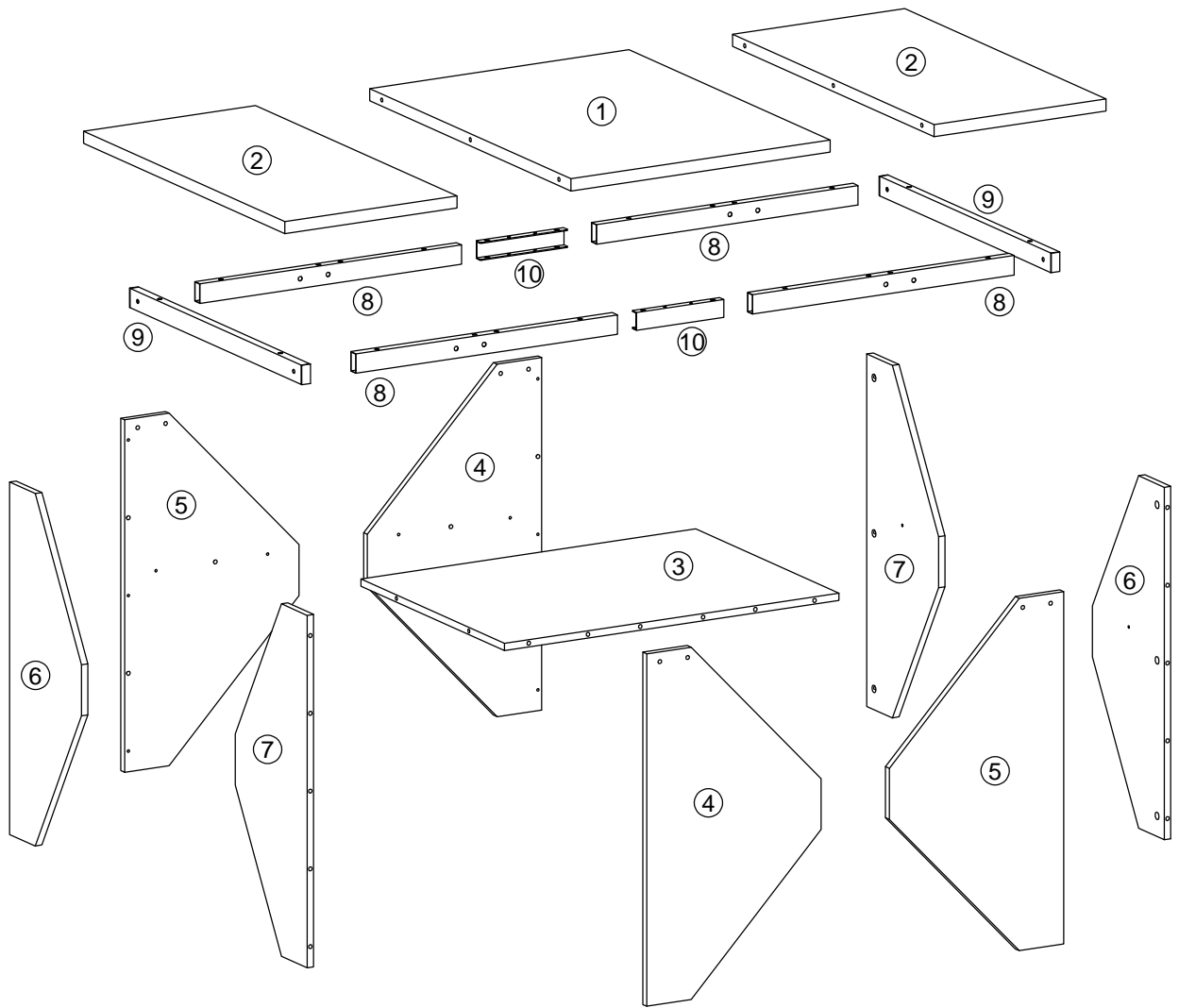

Vor dem Einbau die Schrauben in die Löcher stecken und festziehen, aber nicht bis 100%, 70% bis 80% anziehen reicht aus. Schließlich, nachdem alle Schrauben installiert sind, ziehen Sie alle Schrauben auf 100%. Wenn Sie auf diese Probleme stoßen, z.B. wenn die Löcher nicht ausgerichtet werden können oder einige Teile nicht installiert werden können, überprüfen Sie bitte, ob die Schrauben korrekt verwendet werden und passen Sie die Dichtheit der Schrauben an.

Before installation, insert the screws into the holes and tighten them, but do not tighten them to 100%, 70% to 80% is sufficient. Finally, after all screws are installed, tighten all screws to 100%. If you encounter these issues, such as if the holes cannot be aligned or some parts cannot be installed, please check if the screws are used correctly and adjust the tightness of the screws.

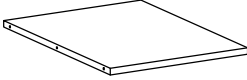
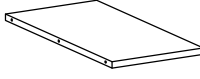

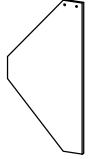

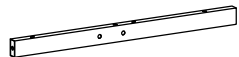
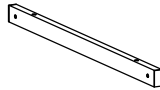



Insérer la vis dans le trou avant la fin de l'assemblage, serrer la vis, mais ne pas serrer à 100%, 70% ~ 80% est bien. Enfin, une fois que toutes les vis sont bien serrées, toutes les vis sont serrées à 100%. Si vous rencontrez ces problèmes, par exemple si les trous ne sont pas alignés ou si certaines pièces ne peuvent pas être montées, vérifiez que les vis sont utilisées correctement et ajustez leur serrage.

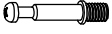

Part List Stückliste

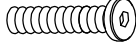
| | | | |
|---|---|--|---|
|  |  |  |  |
| ①×1pc | ②×2pcs | ③×1pc | ④×2pcs |
|  |  |  |  |
| ⑤×2pcs | ⑥×2pcs | ⑦×2pcs | ⑧×4pcs |
|  |  | | |
| ⑨×2pcs | ⑩×2pcs | | |

Hardware List Hardwareliste

| | | | | |
|--|---|--|--|--|
|  φ6×35mm |  φ15×12mm |  φ8×30mm |  M6×12mm |  M6×28mm |
| Ⓐ×24pcs | Ⓑ×24pcs | Ⓒ×18pcs | Ⓓ×4pcs | Ⓔ×8pcs |
|  M6×55mm |  M6×17mm |  |  M4 |  |
| Ⓕ×24pcs | Ⓖ×8pcs | Ⓗ×8pcs | Ⓖ×2pcs | Ⓙ×1pc |

Step 1 Schritt 1

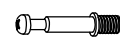

φ6×35mm

(A) ×24pcs

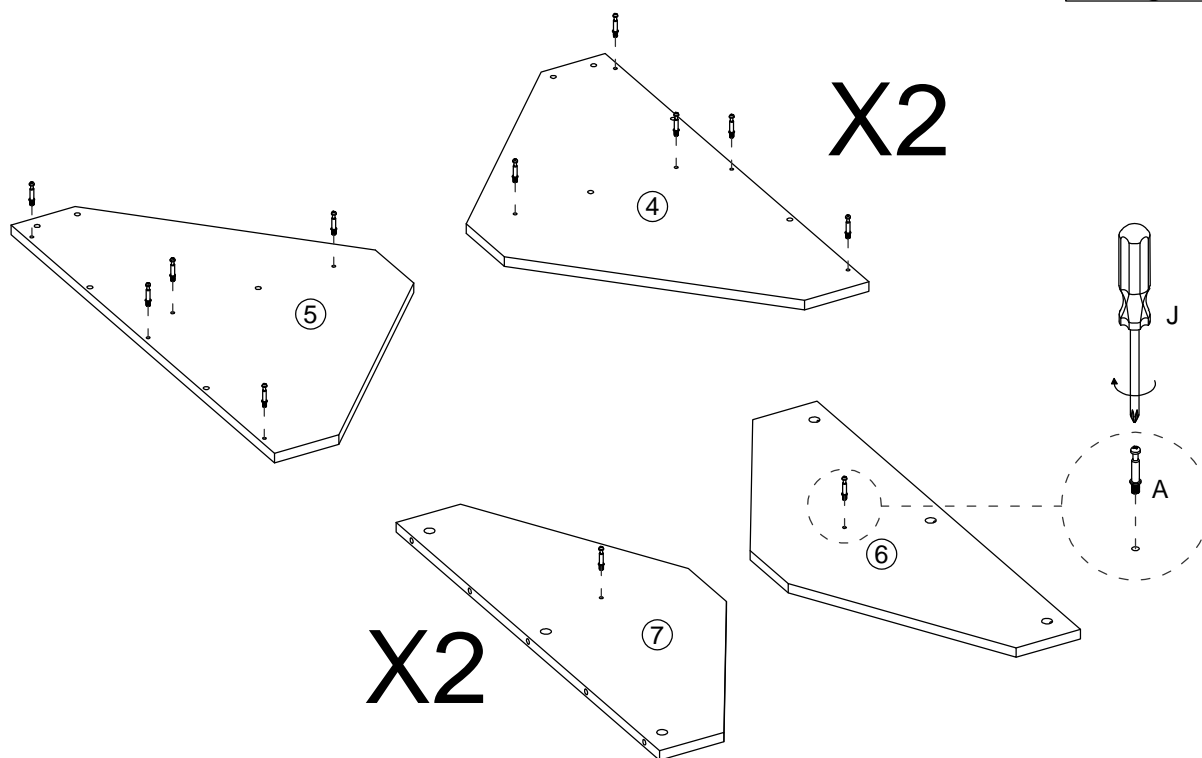

Step 2 Schritt 2



φ15×12mm

(B) ×4pcs

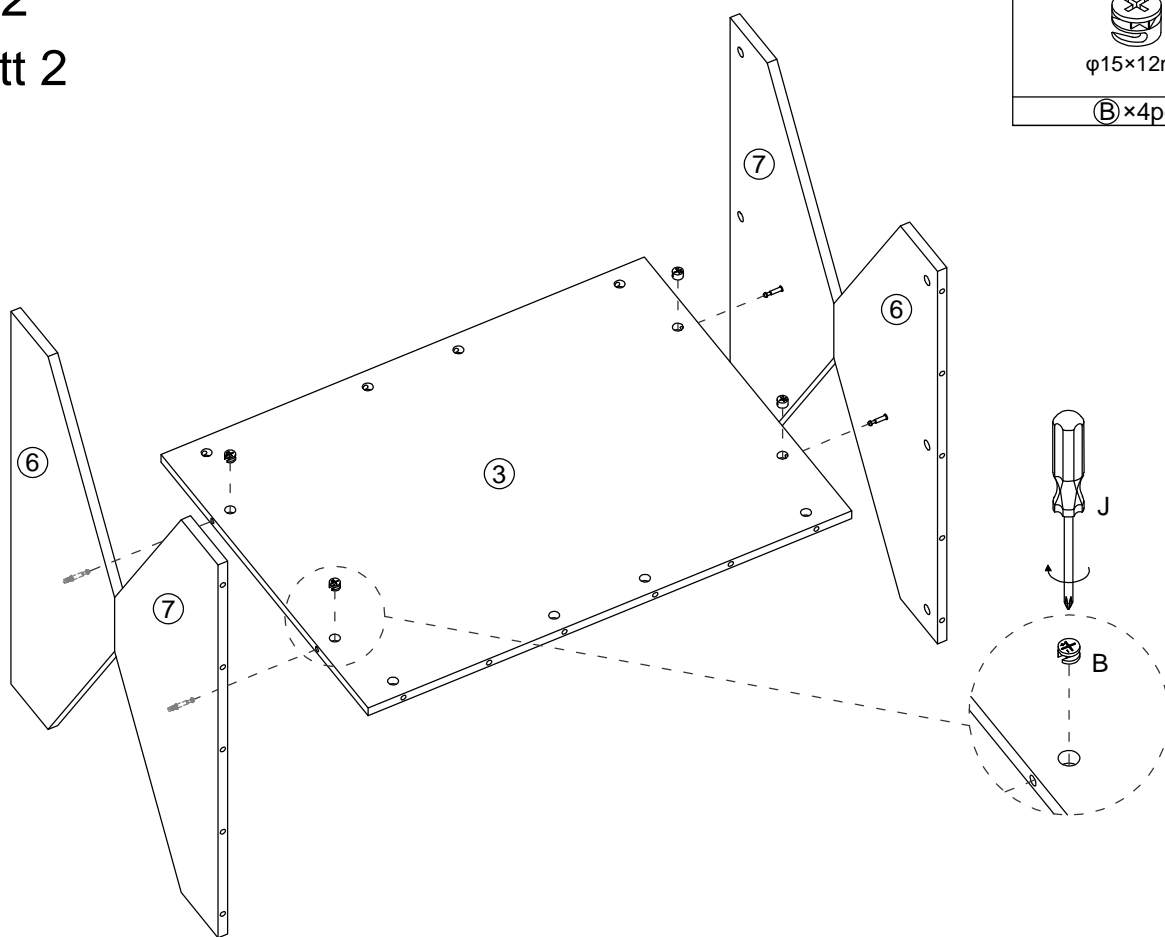

Step 3 Schritt 3

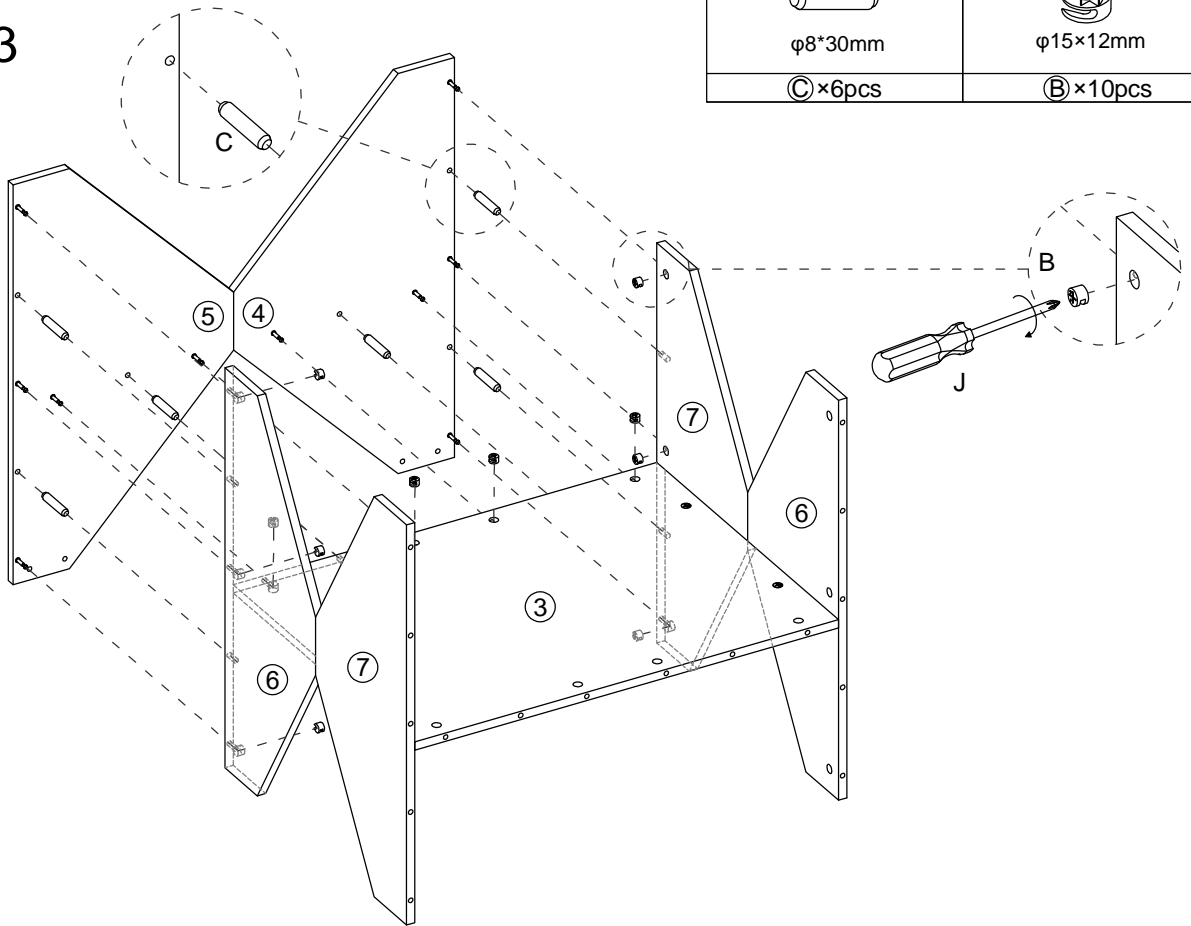

Step 4 Schritt 4

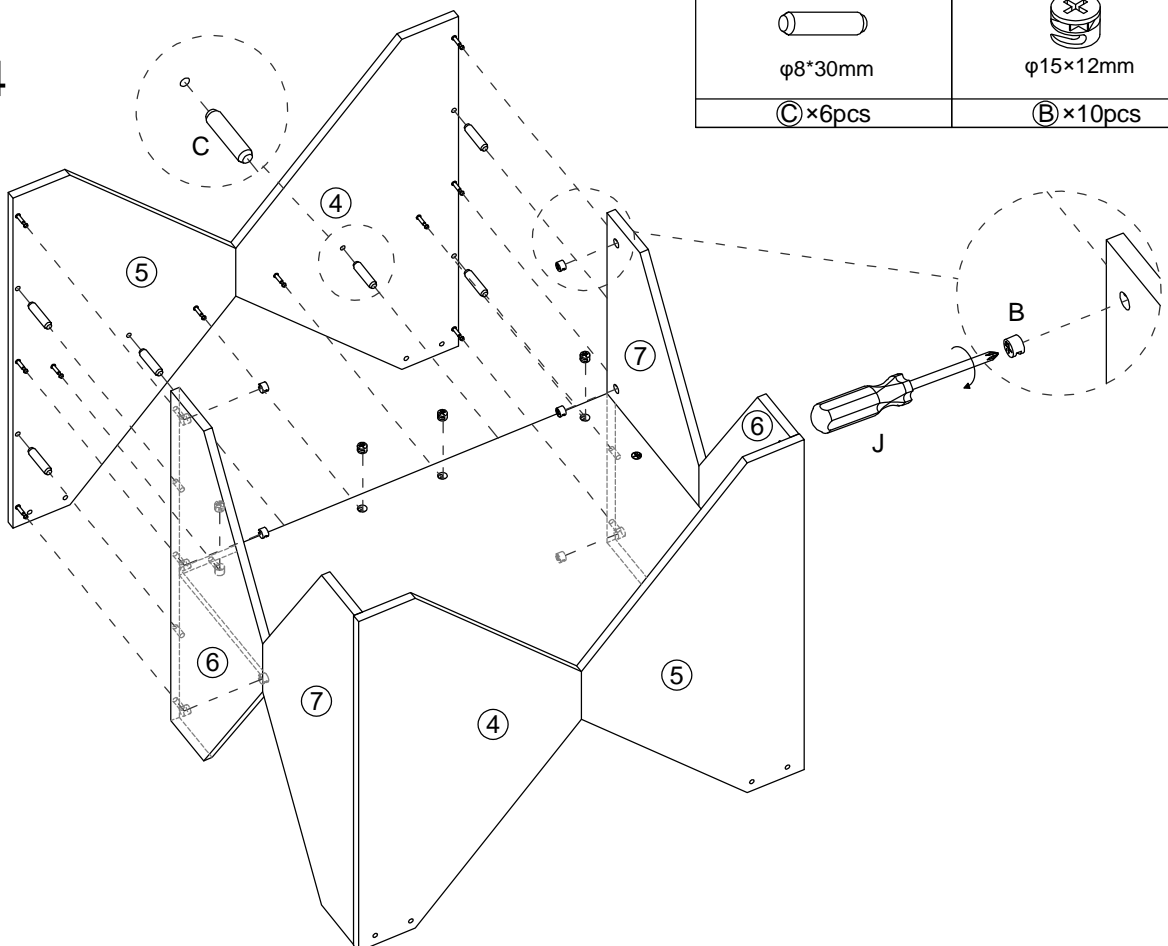

Step 5 Schritt 5

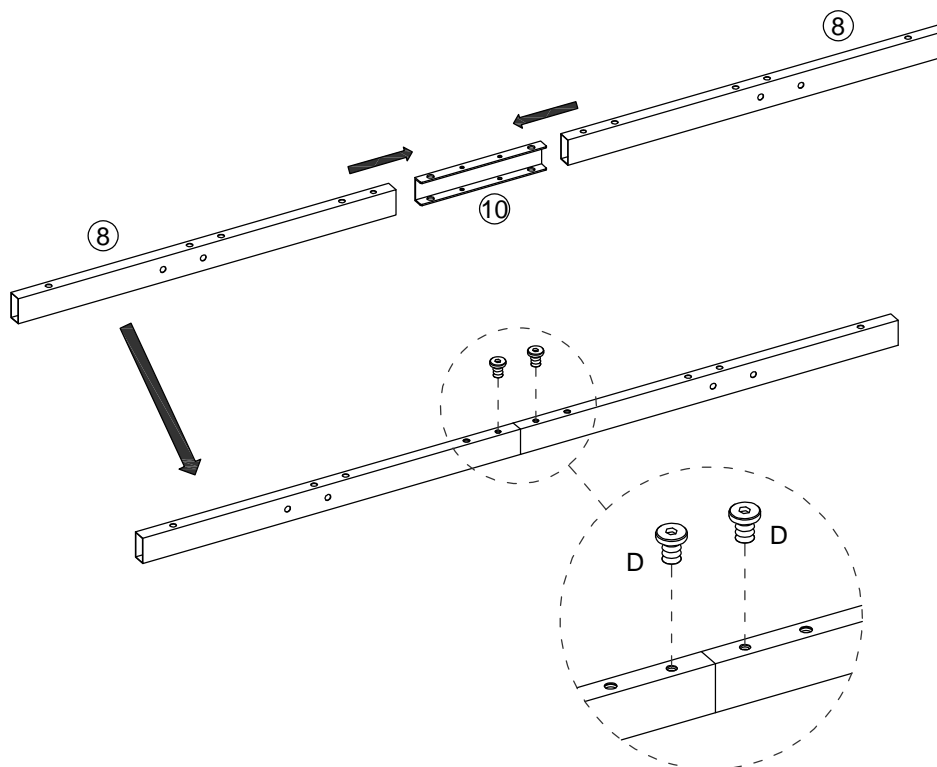

M6×12mm
ⓓ ×4pcs



X2

Step 6 Schritt 6

M6×28mm
ⓔ ×8pcs

M6×17mm
ⓖ ×8pcs

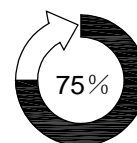
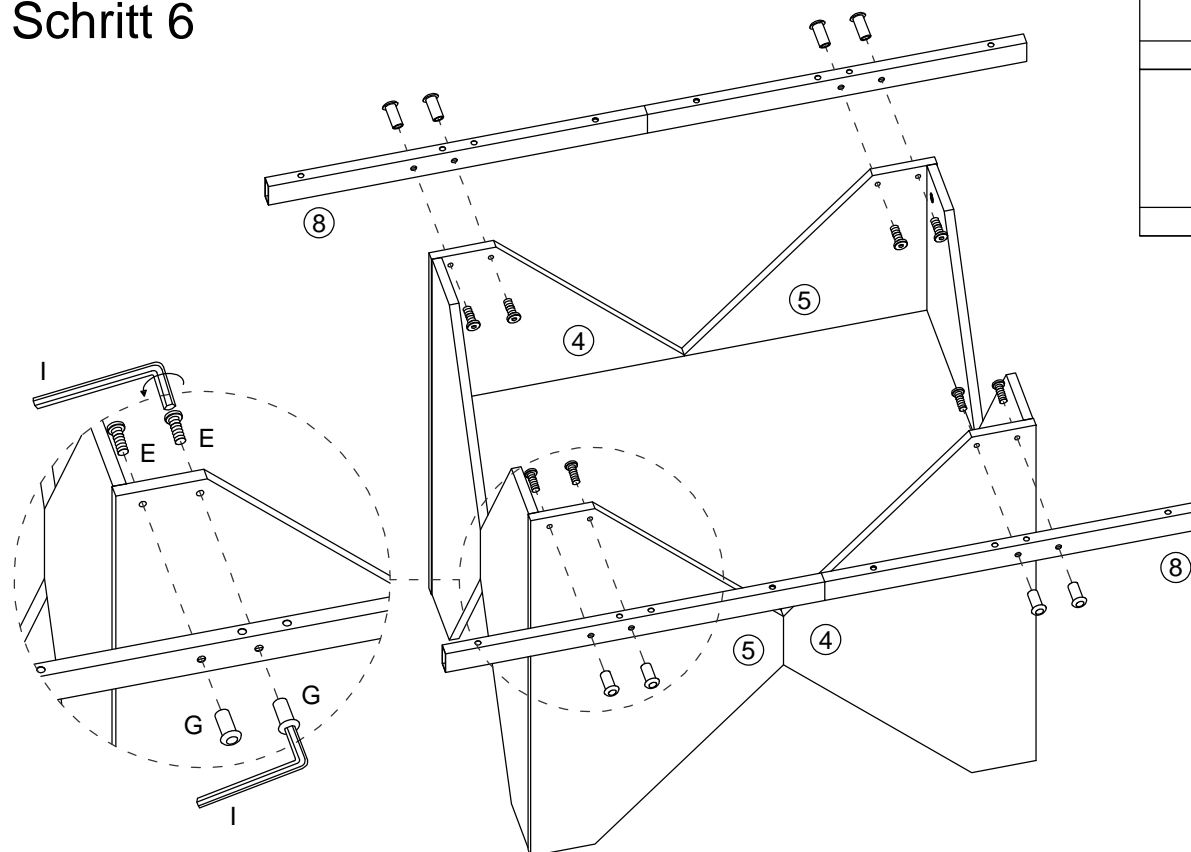

Step 7 Schritt 7

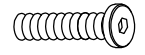

M6×55mm

(F)×4pcs

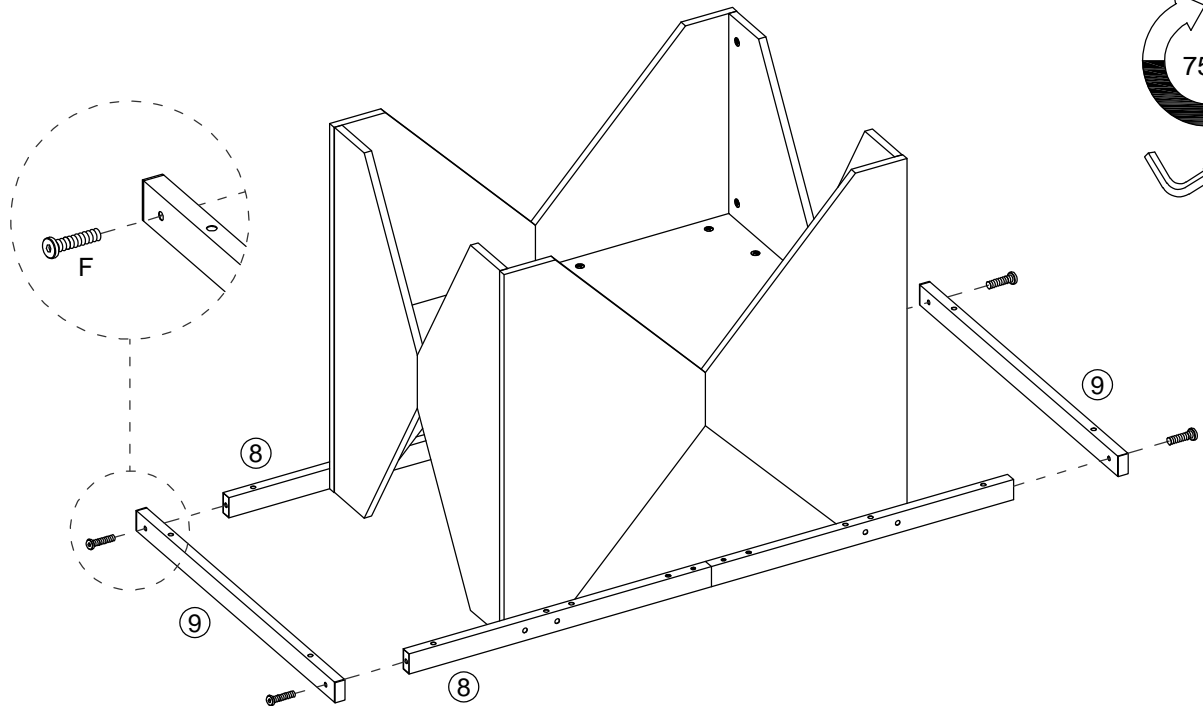
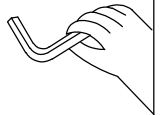

Step 8 Schritt 8

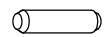

φ8*30mm

(C)×6pcs

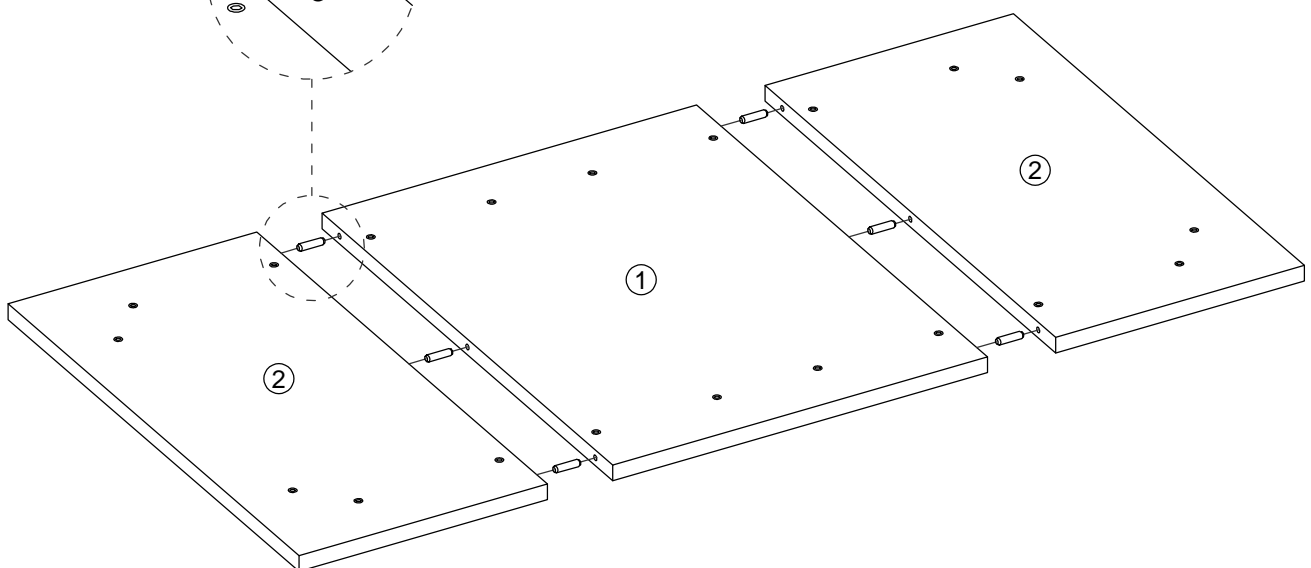
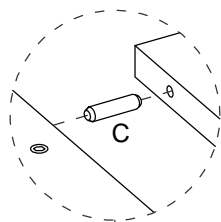

Step 9
Schritt 9

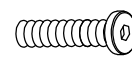
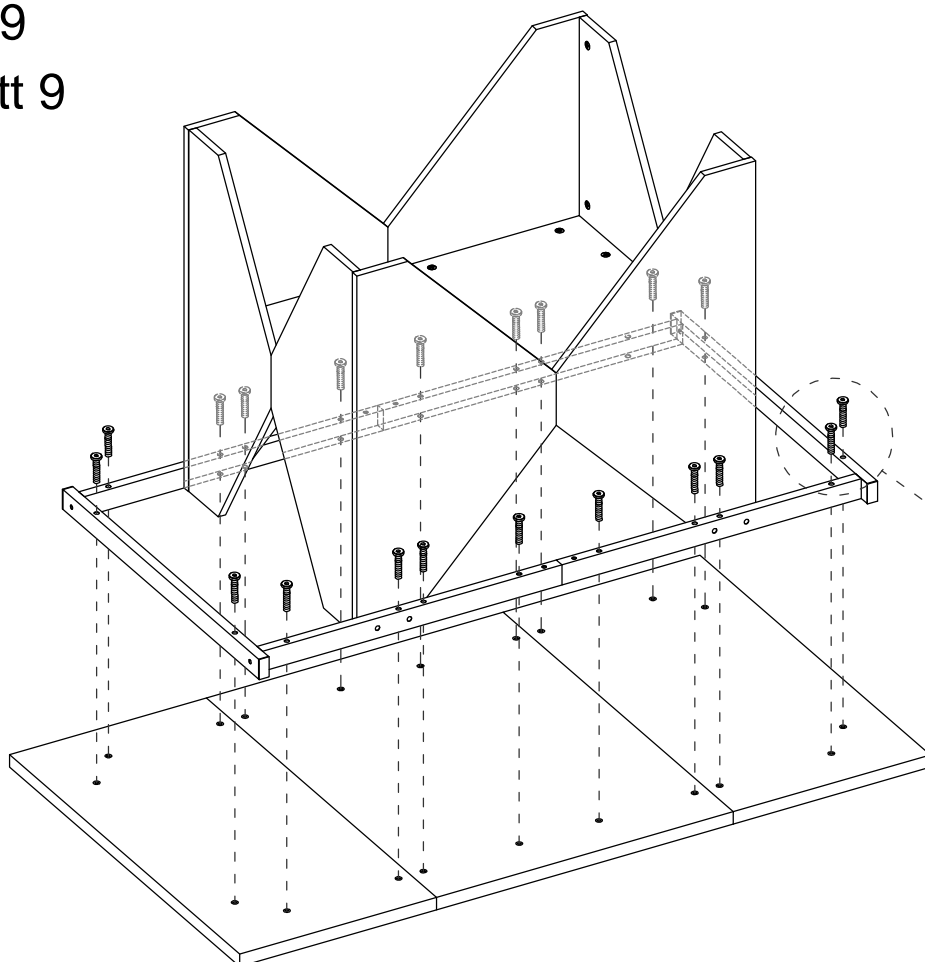

M6×55mm

(F)×20pcs

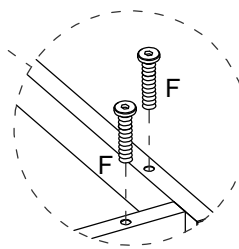

Step 10
Schritt 10



(H)×8pcs

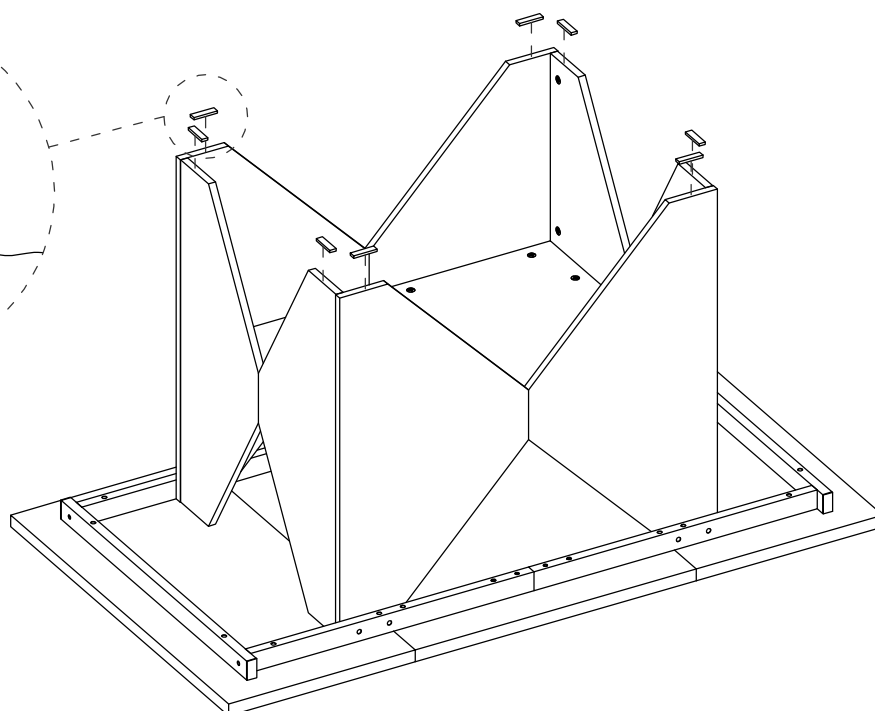
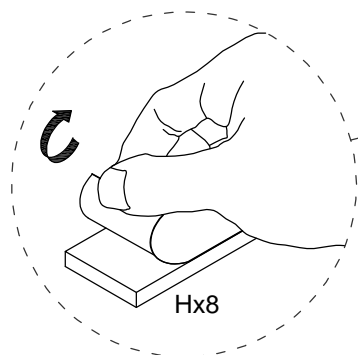

Step 11
Schritt 11

