

**Installation sanleitung
Installation Instruction
Installation d'installation**

Artikelnummer:N636P170865/N636P170866

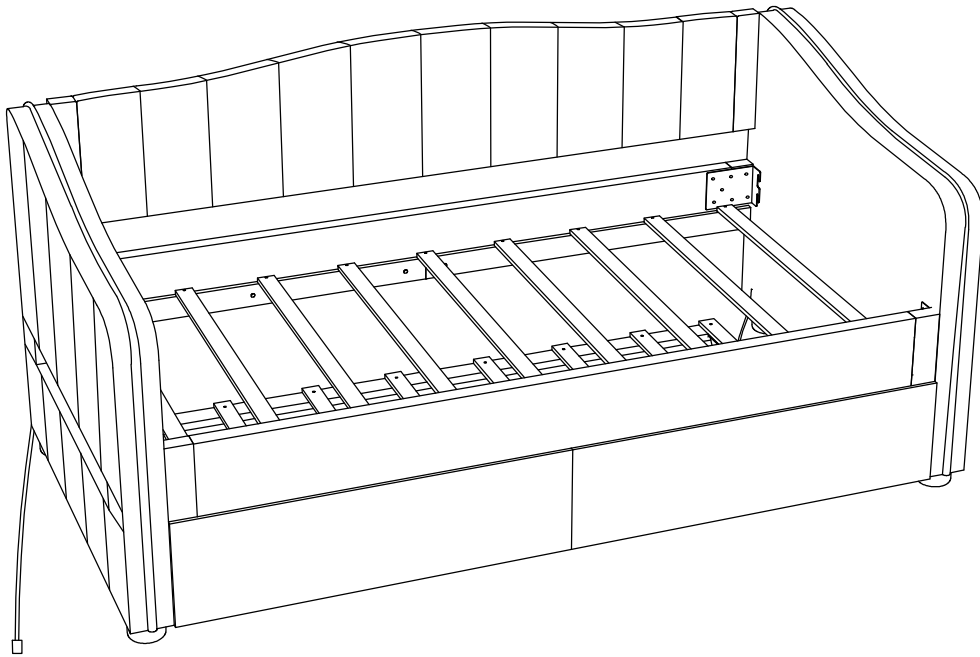

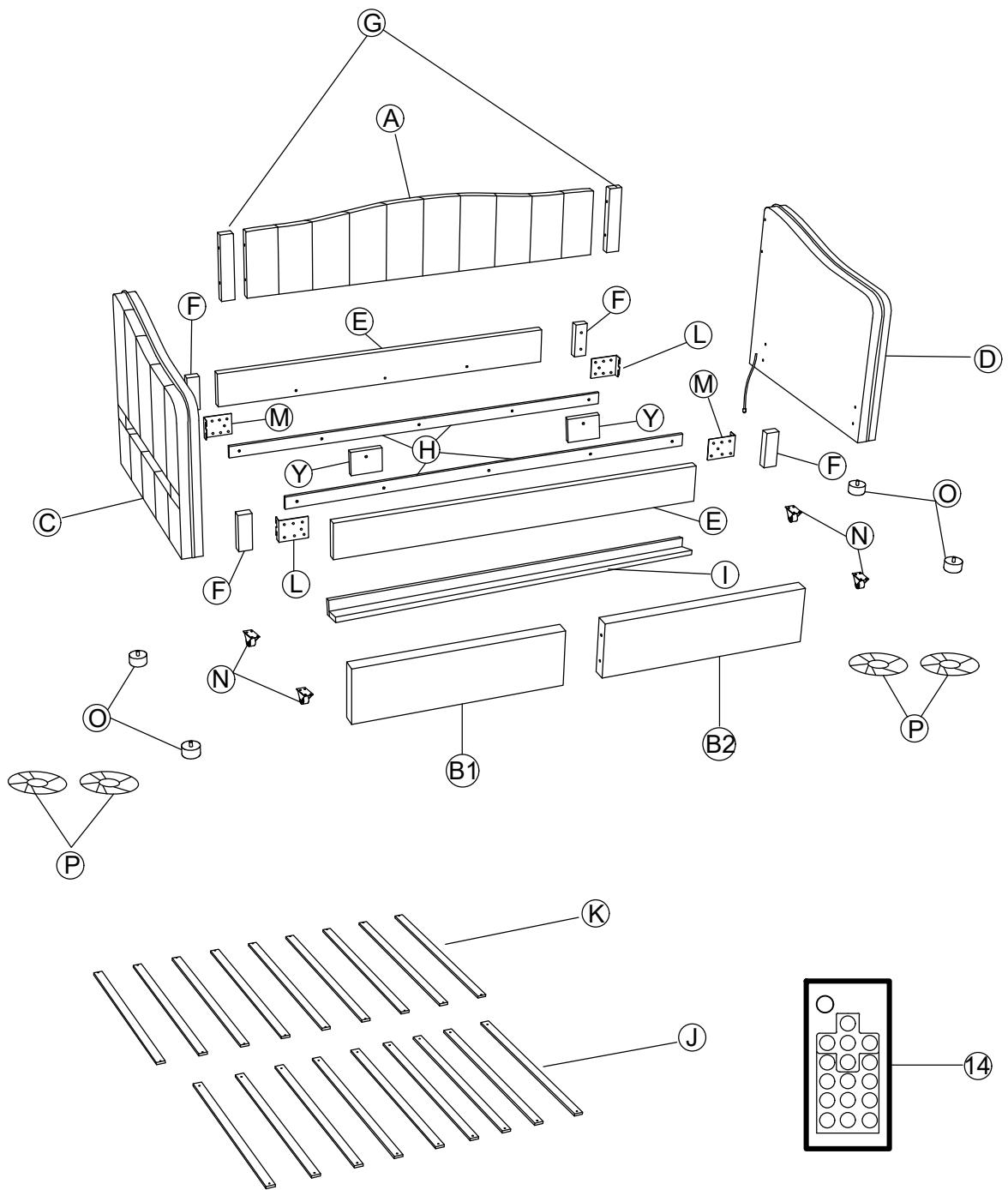







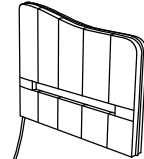
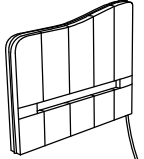
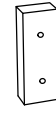

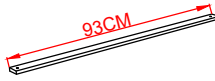
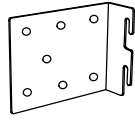
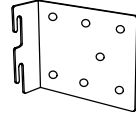

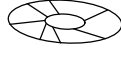









MONTAGEANLEITUNG

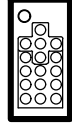

EINE TEILLISTE
DEN HARDWARE KRAM

N636P170865

<p>C</p>  <p>1 pc</p>	<p>D</p>  <p>1 pc</p>	<p>F</p>  <p>4 pcs</p>	<p>B1</p>  <p>1 pc</p>	
<p>B2</p>  <p>1 pc</p>	<p>J</p>  <p>93CM 9 pcs</p>	<p>L</p>  <p>2 pcs</p>	<p>M</p>  <p>2 pcs</p>	<p>N</p>  <p>6 pcs</p>
<p>O</p>  <p>4 pcs</p>	<p>P</p>  <p>4 pcs</p>	<p>Q</p>  <p>1 pc</p>	<p>T</p>  <p>5 pcs</p>	<p>Y</p>  <p>2 pcs</p>
<p>1</p>  <p>M6*20 4PCS</p>	<p>2</p>  <p>M6*35 8PCS</p>	<p>3</p>  <p>M6*55 2PCS</p>	<p>4</p>  <p>M8*40 2PCS</p>	
<p>5</p>  <p>M8*45 8PCS</p>	<p>6</p>  <p>M8*110 4PCS</p>	<p>7</p>  <p>M4*16 24PCS</p>	<p>8</p>  <p>M4*25 18PCS</p>	
<p>9</p>  <p>M4*30 18PCS</p>	<p>10</p>  <p>M6*18*1 2PCS</p>	<p>11</p>  <p>M8*20*2 14PCS</p>	<p>12</p>  <p>M6 1pc</p>	
<p>13</p>  <p>M8 1PC</p>	<p>14</p>  <p>1PC</p>	<p>15</p>  <p>M10 1PC</p>	<p>16</p>  <p>M4*14 24PCS</p>	

EINE TEILLISTE

N636P170866

A

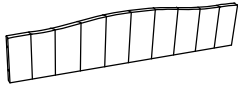

1 pc

G



2 pcs

E



2 pcs

H

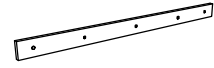

2 pcs

I





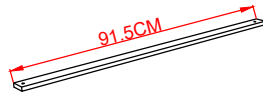

1 pc

K

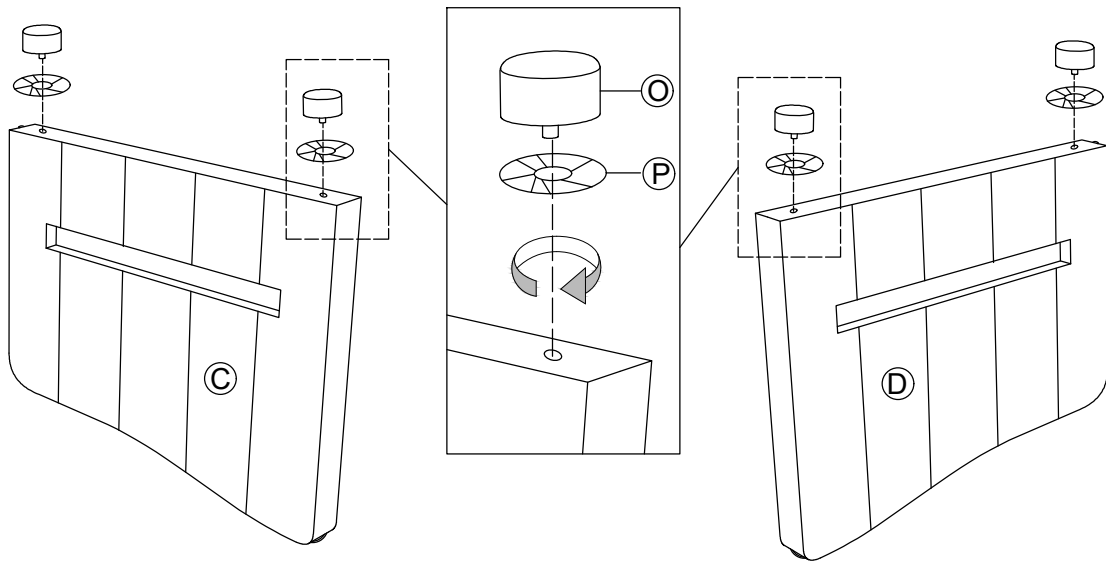





9 pcs

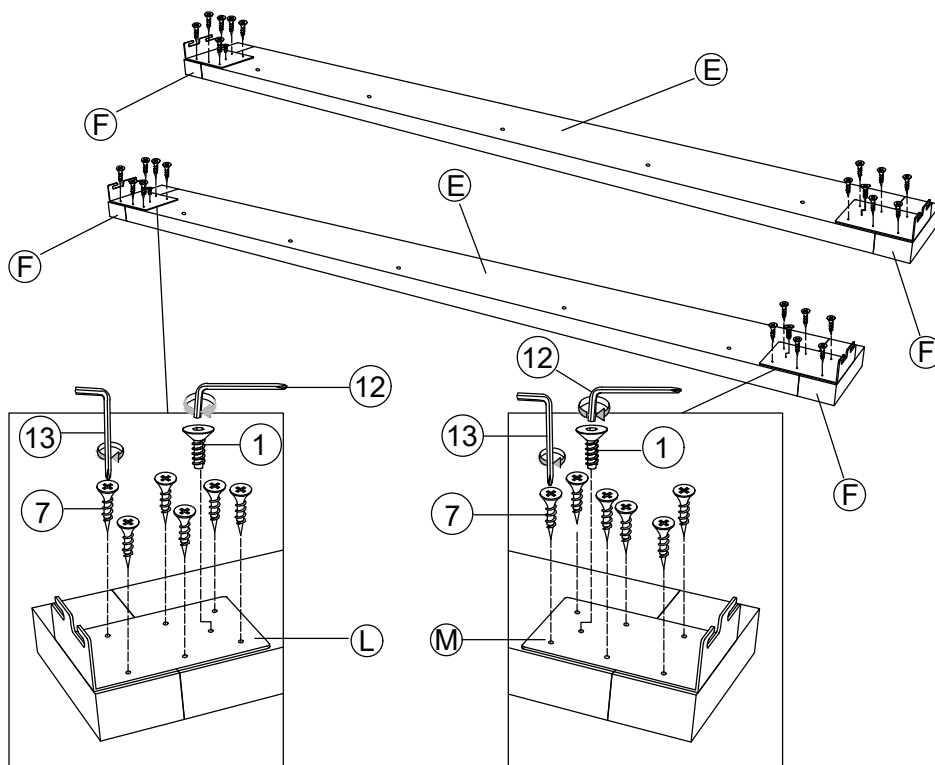

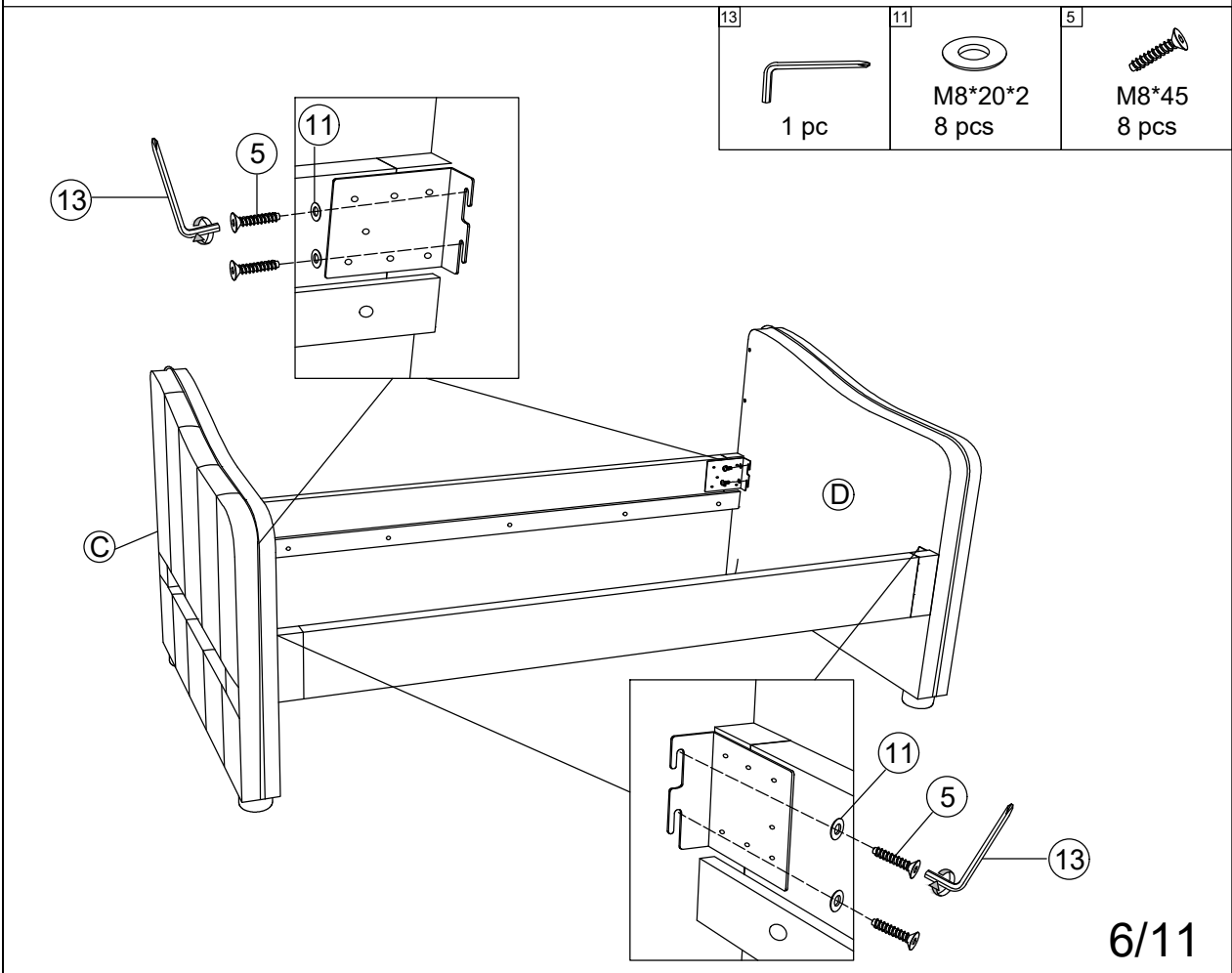
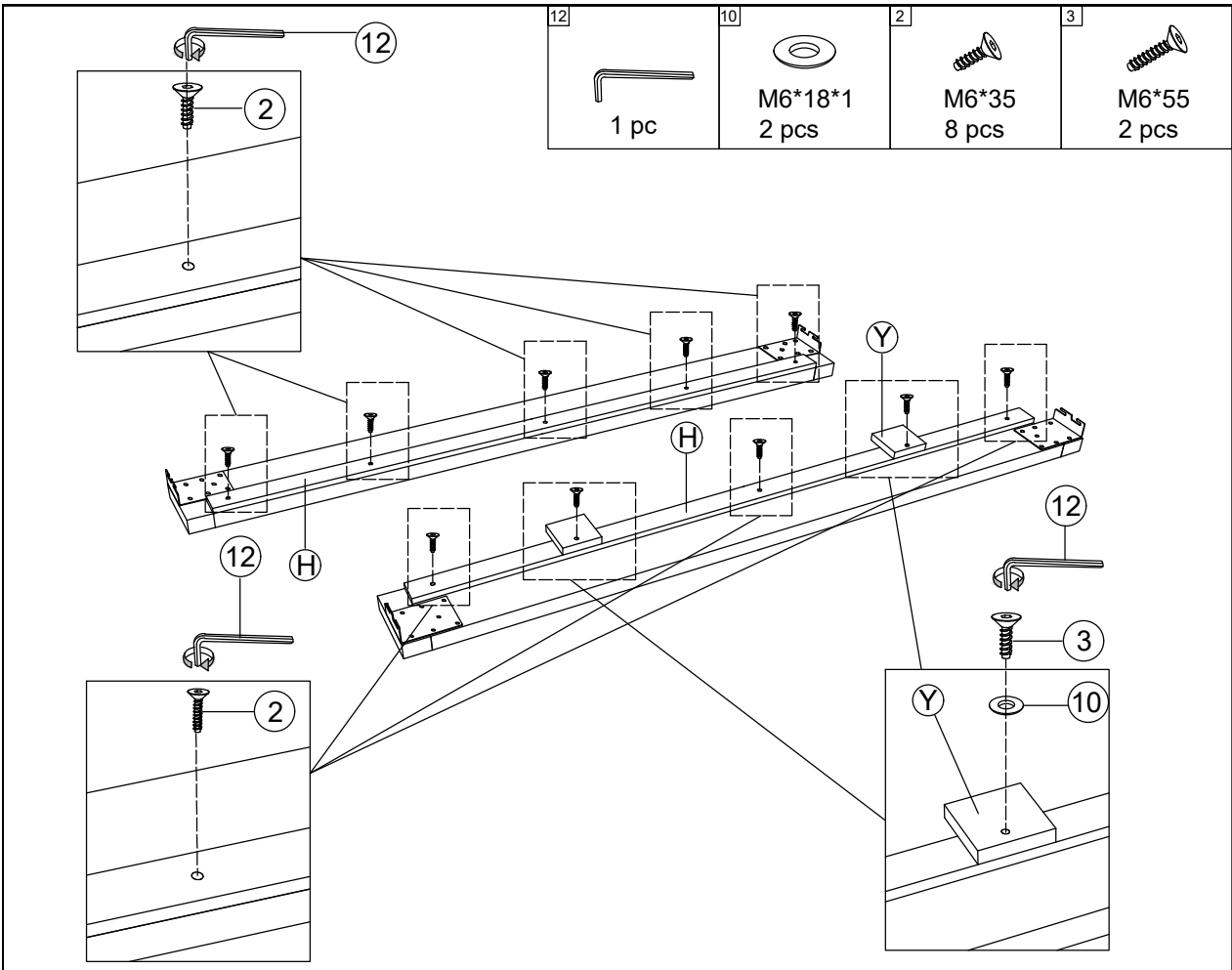

<p>13</p>  <p>1 pc</p>	<p>12</p>  <p>1 pc</p>	<p>7</p>  <p>M4*16 24 pcs</p>	<p>1</p>  <p>M6*20 4 pcs</p>
---	--	--	---





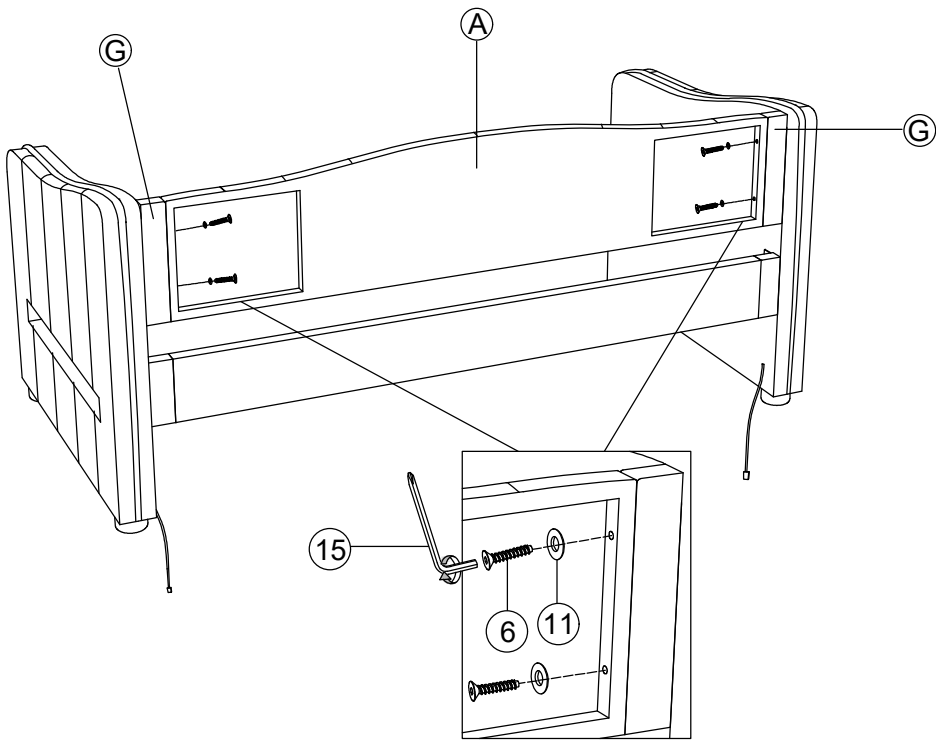



<p>15</p>  <p>1 pc</p>	<p>11</p>  <p>M8*20*2 4 pcs</p>	<p>6</p>  <p>M8*110 4 pcs</p>
--	--	--

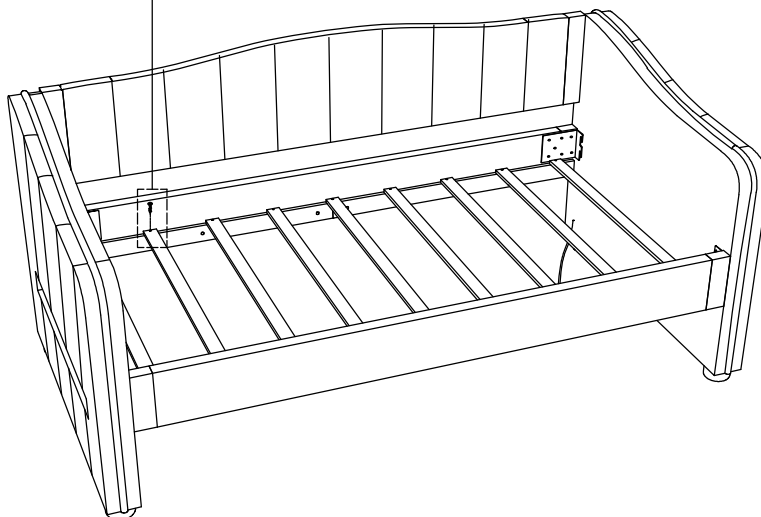
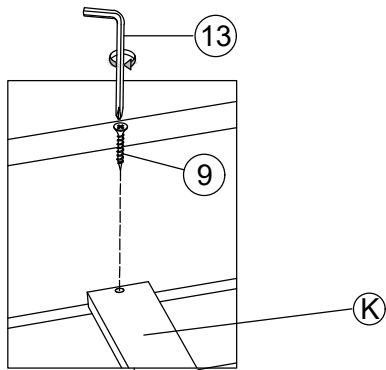



<p>13</p>  <p>1 pc</p>	<p>9</p>  <p>M4*30 18 pcs</p>
---	--



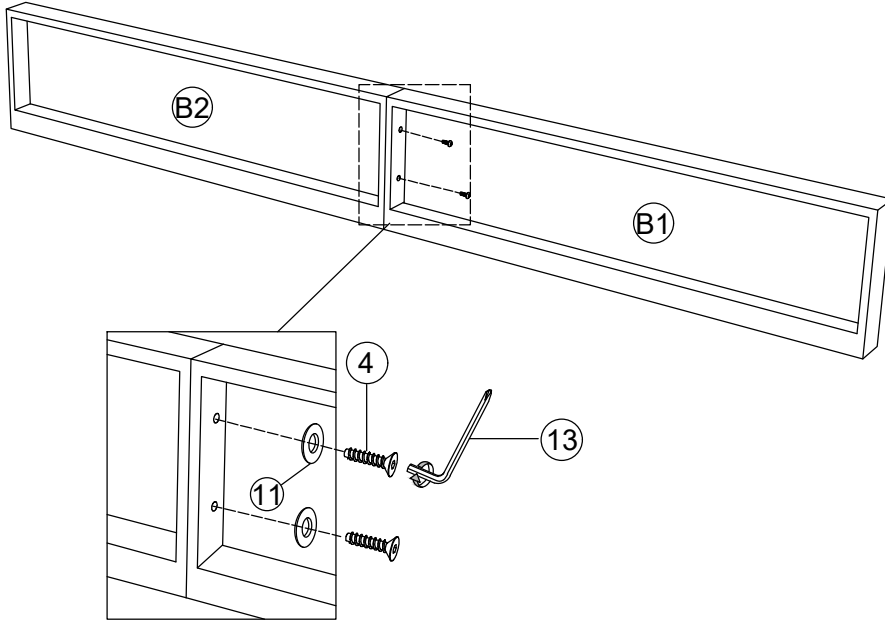

<p>13</p>  <p>1 pc</p>	<p>11</p>  <p>M8*20*2 2 pcs</p>	<p>4</p>  <p>M8*40 2 pcs</p>
--	--	---

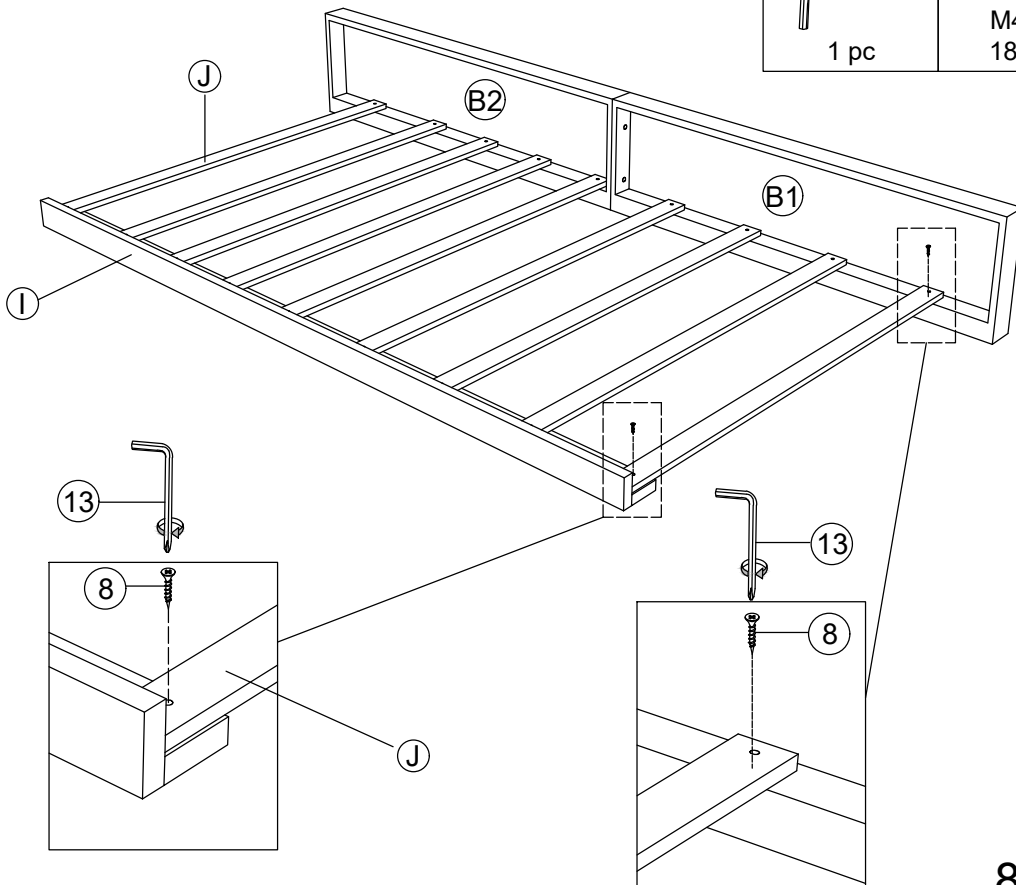

<p>13</p>  <p>1 pc</p>	<p>8</p>  <p>M4*25 18 pcs</p>
---	--



<p>13</p>  <p>1 pc</p>	<p>16</p>  <p>M4*14 24 pcs</p>
---	---

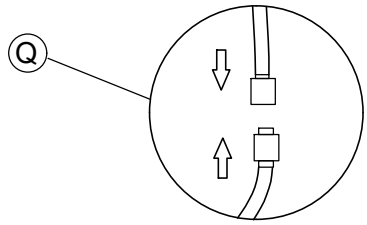
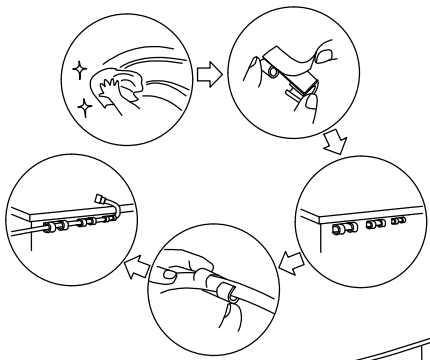
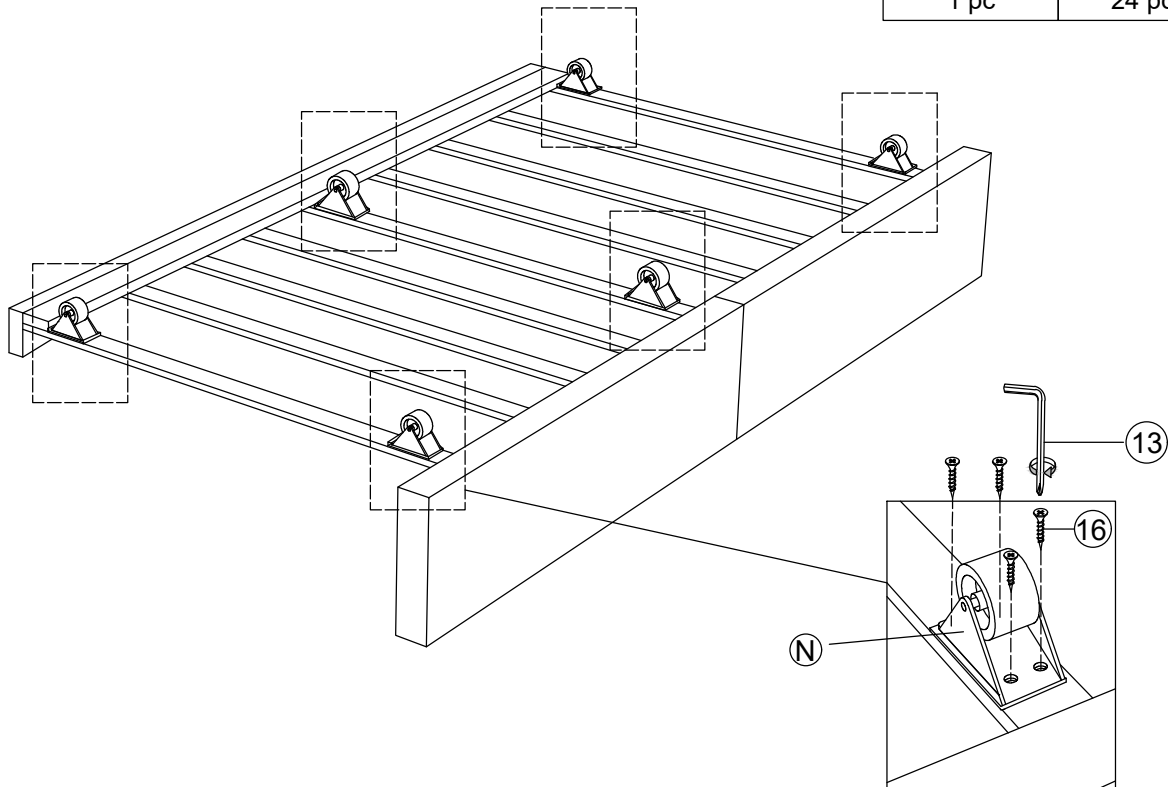

<p>T</p>  <p>5 pcs</p>

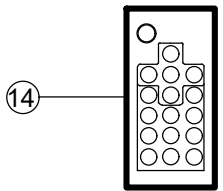
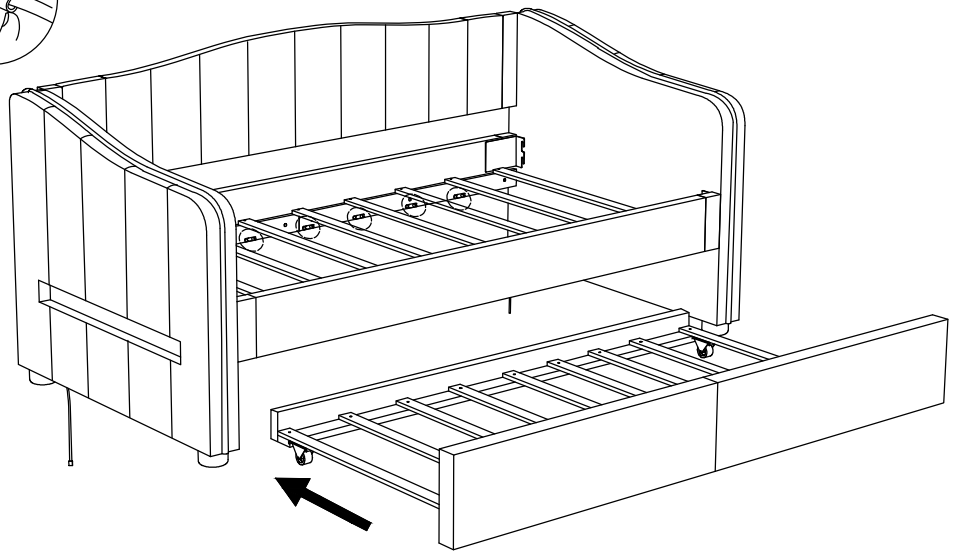

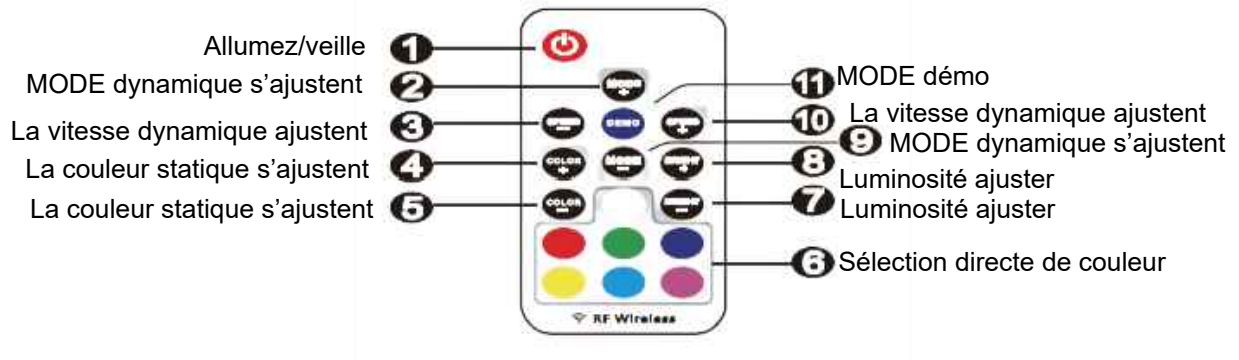
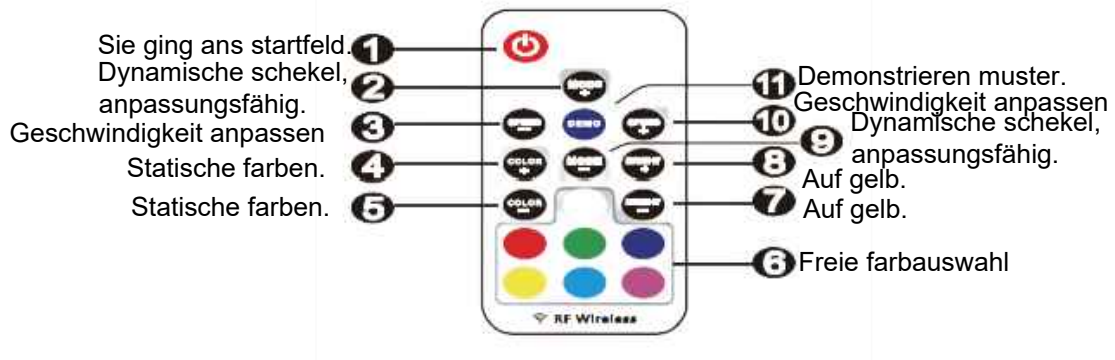
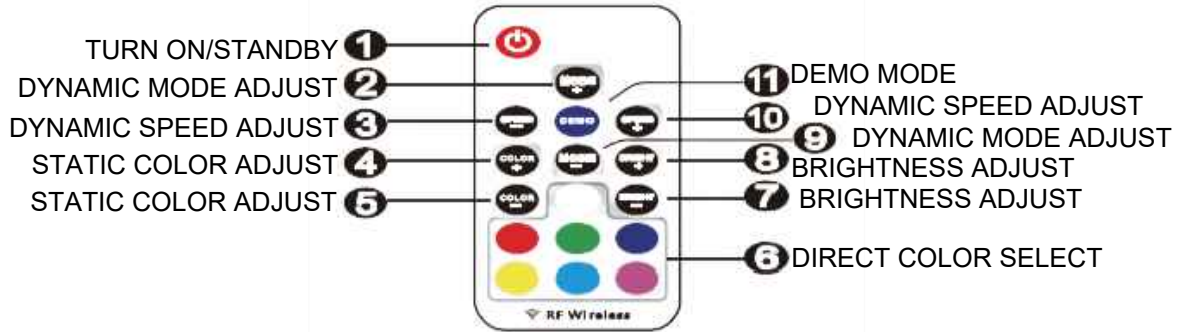

Shenzhen ZKT Technology Co., Ltd.
1/F, No. 101, Building B, No. 6, Tangwei Community Industrial Avenue,
Fuhai Street, Bao'an District, Shenzhen, China



Certificate of Compliance

Certificate Number: ZKT-2403202774C

Certificate's Holder : Shenzhen Pinchengxin Technology Co., Ltd
3rd Floor, 8th Building Yuanling Industrial Zone, No. 39
Yuanlingcun Road, Shiyao Street, Bao'an District,
Shenzhen

Manufacturer : Shenzhen Pinchengxin Technology Co., Ltd
3rd Floor, 8th Building Yuanling Industrial Zone, No. 39
Yuanlingcun Road, Shiyao Street, Bao'an District,
Shenzhen

Trade Mark : N/A

Product : 5050 RGB LED Strip Lights with RF Controller and RF Remote

Model(s) : 5050 RGB LED Strip Lights

Test Standard	Art.3.1(a) Safety	EN IEC 62368-1:2020+A11:2020
	Art.3.1(a) Health	EN 62479: 2010 EN 50663:2017
	Art.3.1(b) EMC	ETSI EN 301 489-1 V2.2.3 (2019-11) ETSI EN 301 489-3 V2.3.2 (2023-01)
	Art.3.2 Radio	ETSI EN 300 220-1 V3.1.1 (2017-02) ETSI EN 300 220-2 V3.2.1 (2018-06)

This Attestation of Compliance is issued on a voluntary basis for electrical equipment below the voltage limits of Radio Equipment Directive (RED) 2014/53/EU. The essential requirements are fulfilled accordingly based on the technical specifications applicable at the time of issuance.



This Certificate of Conformity is based on single evaluation of the submitted sample(s) of the above mentioned product. It does not imply an assessment of the whole product and relevant Directives to be observed.

+86-400 000 9970 +86-755-22336688 zkt@zkt-lab.com www.zkt-lab.com