

## 1. Fundamente / Foundations / Fondations / Stichtingen

242887 - 1176x634cm

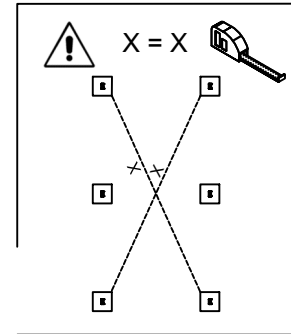
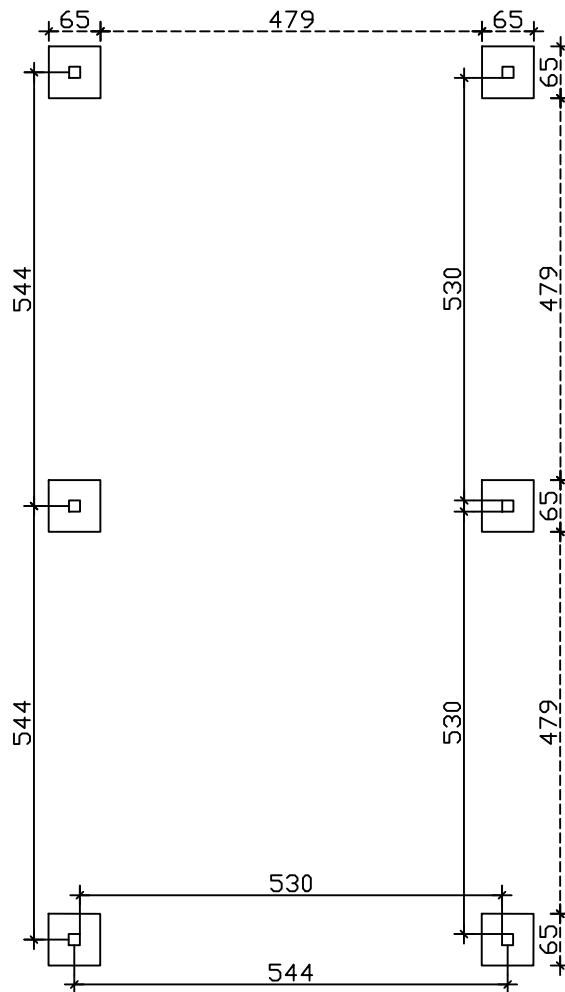

**Beachten Sie bitte, dass bei dem Einbau einer Rückwand oder eines Abstellraumes eventuell weitere Fundamente erforderlich sind. Siehe Aufbauanleitung vom Zubehör.**  
 Note that with the installation of a rear wall of a store room or possibly other foundations are required please. See installation instructions from the accessories.

Notez que l'installation d'un mur arrière d'une salle de magasin ou éventuellement d'autres fondations sont nécessaires se il vous plaît. Voir les instructions d'installation des accessoires.

Merk op dat bij de installatie van een achterwand van een opslagruimte of mogelijk andere fundering nodig geduld. Zie de installatie-instructies van de accessoires.

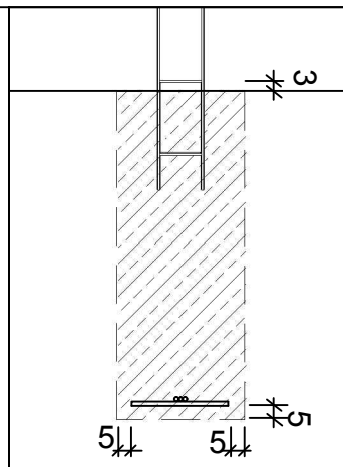
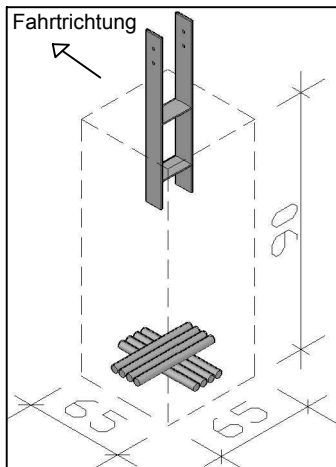

**Fundamente gemäß Statik (Nicht im Lieferumfang enthalten !)**

- Beton C25/30
  - Betonstahl 500(M), je 4 Stk. M12 kreuzweise
  - Betondeckung 5cm
- Foundations as per structural (Not included!)
- concrete C25/30
  - reinforcing steel 500 (M), each 4 Pcs M12 criss-cross
  - concrete cover 5cm

Fondations voir statique (Non inclus!)

- Beton C25/30
- L'acier d'armature 500 ( M ) , chacun 4 pcs M12 transversales.
- Béton couvercle 5cm

Stichtingen volgens statica (Niet inbegrepen!)

- Beton C25/30
- Versterking van de stalen 500 ( M ) , elk 4 stuks M12 dwars.
- Betondekking 5cm

## 2. Pfosten / Posts / Poteaux / Paal - LH14/14

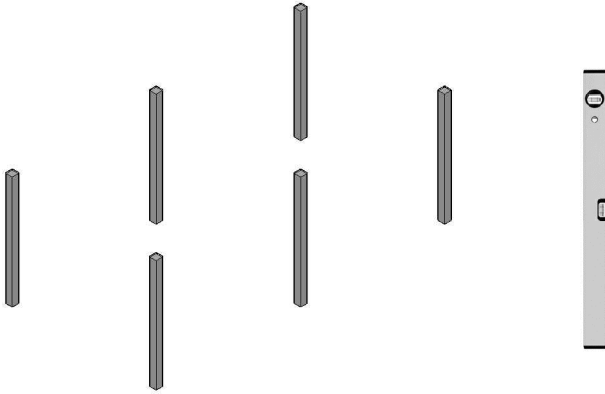

## 3. Anker zum Einbetonieren / Anchor / Ancrage / Paalankers - C130-140

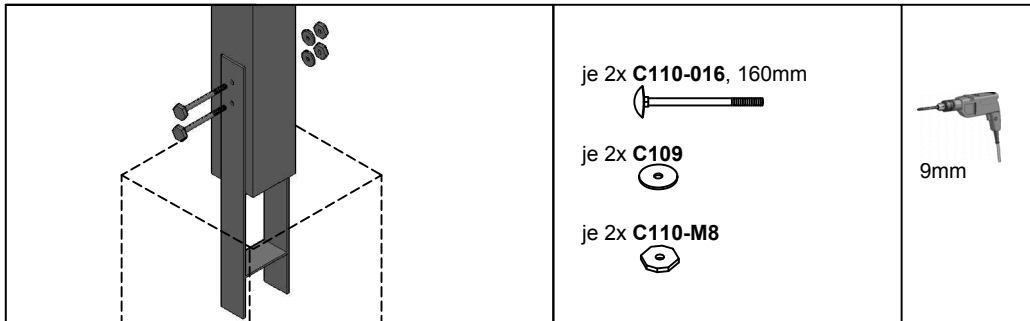

## 4. Pfetten / Purlins / Pannes / Gordingen - LH14/14

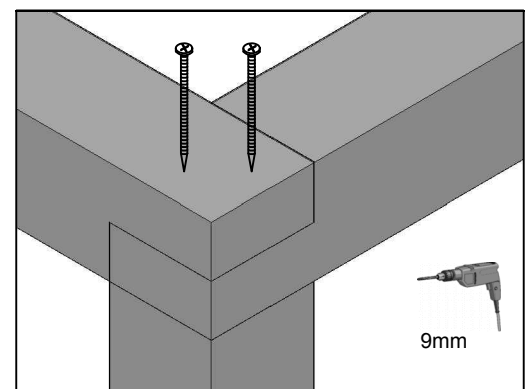
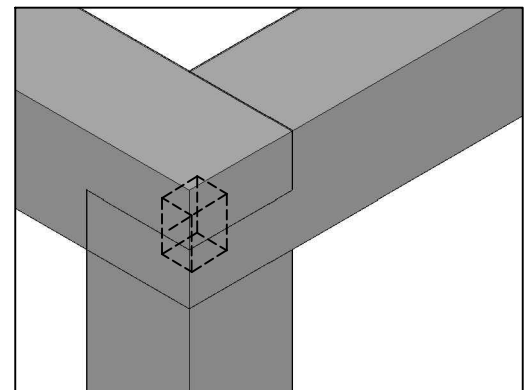
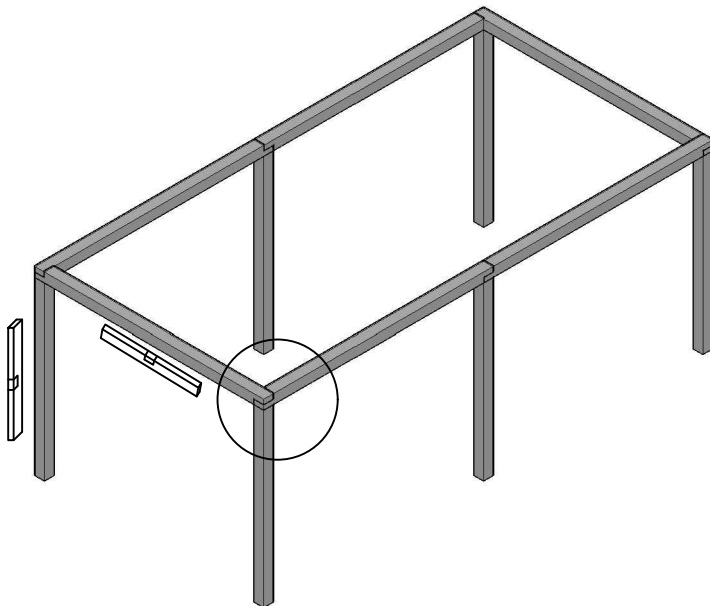

2 x **C105-212**  212mm

# Aufbauanleitung

Assembly instructions / Instructions de montage / Montagehandleiding



## 5. Kopfbänder / Head bands / Bandeaux / Hoofdbanden - LH10/10

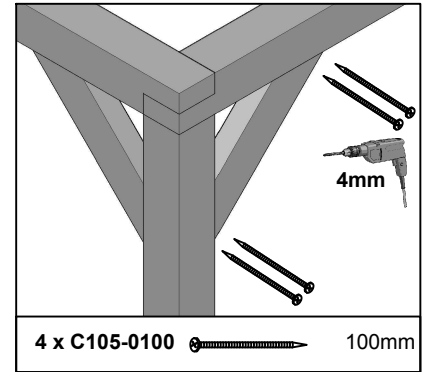
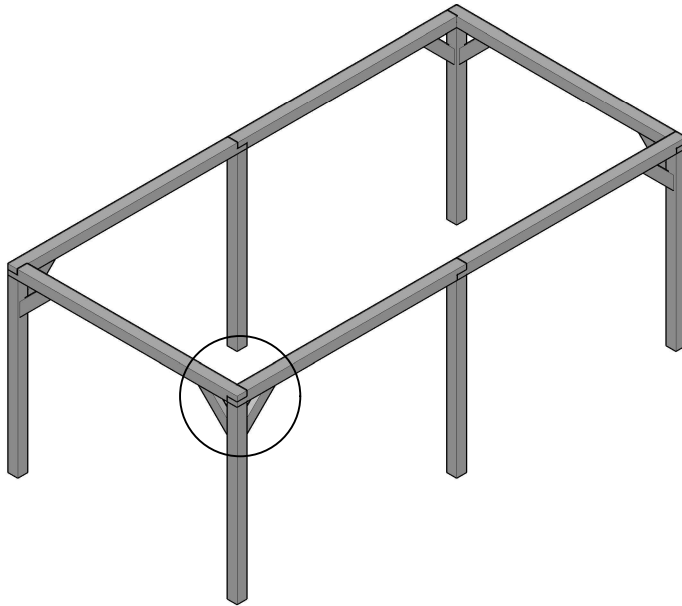

## 6. Sparren / Rafter / Chevron / Aanloper - LH6/16

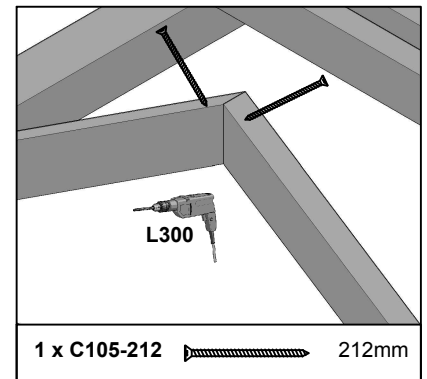
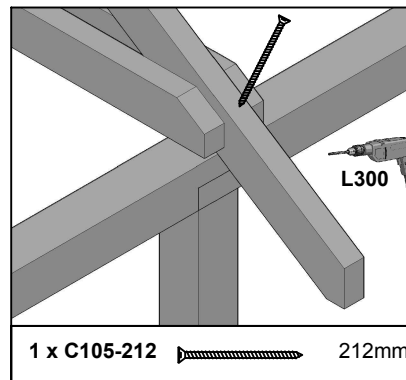
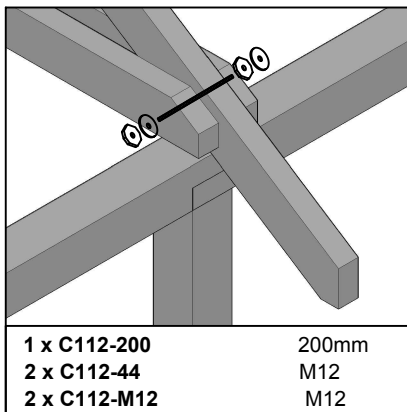
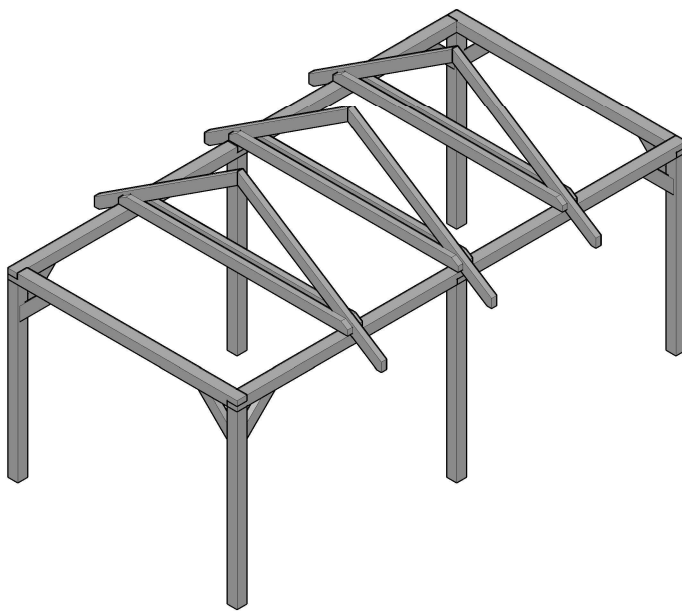

## 7. Sparren / Rafter / Chevron / Aanloper - LH8x22 / LH6/16

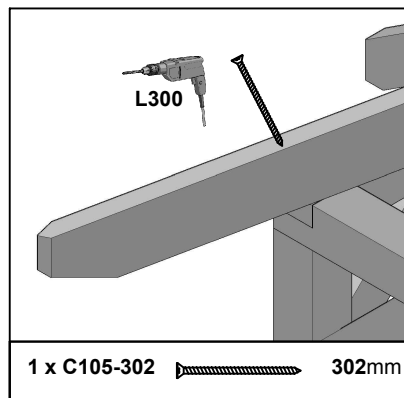
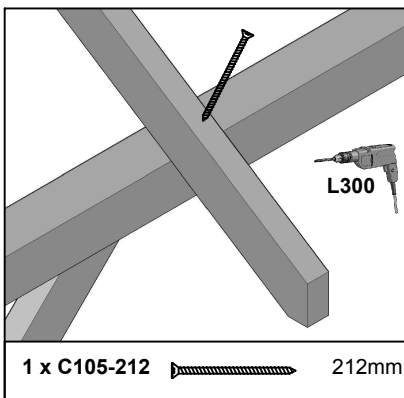
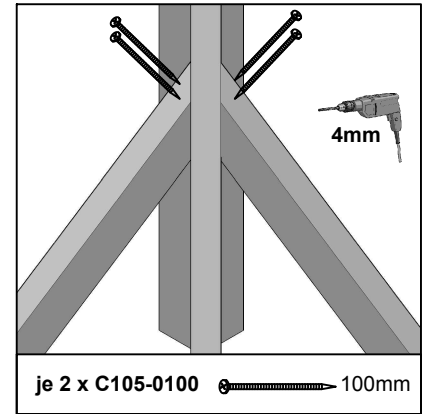
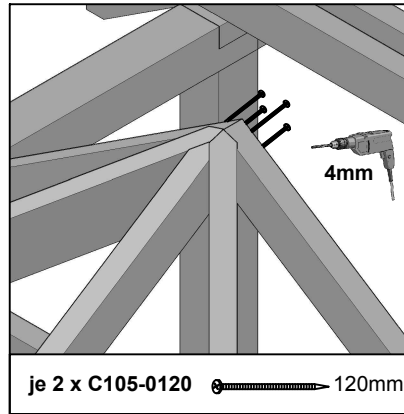
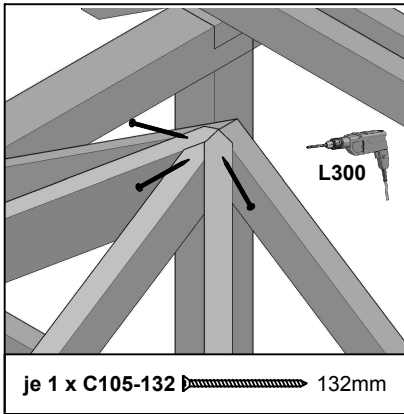
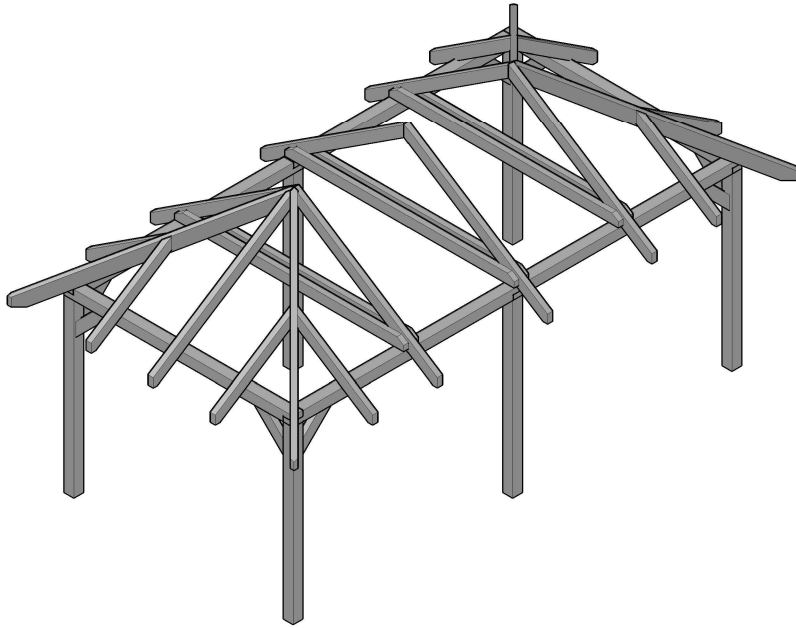

# Aufbauanleitung

Assembly instructions / Instructions de montage / Montagehandleiding



## 8. Dacheindeckung / Roofing / Toiture / Dakbedekking

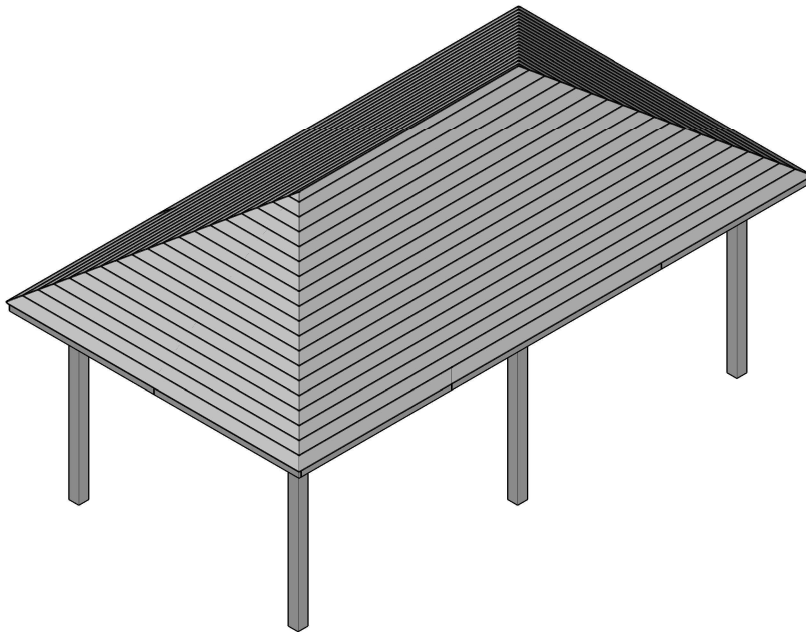

	<p><b>UH2/12</b>  3mm</p> <p>+</p> <p><b>C105-0040</b>  40mm</p> <p>Die Dachbretter werden mit je <u>zwei Schrauben pro Sparren verschraubt.</u> Les panneaux de toit sont vissés ensemble avec deux vis par chevron. The roof boards are screwed together with two screws per rafter.</p>
--	--



**Die Dachbretter werden vorgeschritten geliefert und müssen beim weiteren Verlegen ggf. gekürzt werden. Durch Ausrichten der Winkelschnitte der unteren Reihe auf Sparrenmitte ergibt sich der Dachüberstand.**

The roof boards are delivered pre-cut and must be shortened if necessary. By aligning the angle sections of the lower row on the center of the rafter, the roof overhang results.

Les panneaux de toit sont livrés pré-coupés et doivent être raccourcis si nécessaire. En alignant les sections angulaires de la rangée inférieure au centre du chevron, le surplomb du toit résulte.

	<p><b>UH2/8</b>  3mm</p> <p>+</p> <p><b>C105-0040</b>  40mm</p>
--	---