



Artikel Nr.: 730410

Deckenaufbauleuchte, Mob Square II Anthracite, Anthrazit, 220-240V AC/50-60Hz, 9,00

Technische Daten

Charakteristik

Material	Aluminium Druckguß
Farbe	Anthrazit
Optik	
im Lieferumfang	



Elektrische Daten

Leistung	9,00 W
Eingangsspannung	220-240V AC/50-60Hz
Eingangsstrom	
Fassung / Sockel	GX53
Anzahl Sockel	1
Netzgerät	
Ansteuerung	nicht dimmbar
Anschlussmöglichkeit	Klemme
Schutzklasse I, II, III	I



Artikel Nr.: 730410

Deckenaufbauleuchte, Mob Square II Anthracite, Anthrazit, 220-240V AC/50-60Hz, 9,00

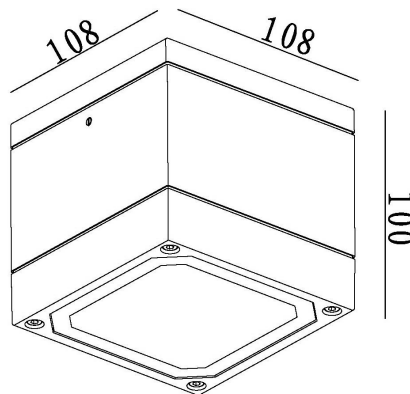

Lichtrichtung

Dreh- und Schwenkbereich	feststehend
Neigungswinkel	0°
Abstrahlverhalten	
Reflektor / Linse	

Abmessungen und Gewicht

Länge	108 mm
Breite	108 mm
Höhe	100 mm
Durchmesser	
Deckenabhängung	
Gewicht	653 g

Sockelmaß

Länge	108 mm
Breite	108 mm
Höhe	
Durchmesser	



Artikel Nr.: 730410

Deckenaufbauleuchte, Mob Square II Anthracite, Anthrazit, 220-240V AC/50-60Hz, 9,00

Grenzwerte

Betriebstemperatur	-20°C - +40°C
Lagertemperatur	-10°C - +60°C
IP - Schutzart	IP 54

IP 54 Schutz gegen das Eindringen von Staub. (Staubschutz) Geschützt gegen Spritzwasser.



Leuchte der Schutzklasse I bei der der Schutz gegen elektrischen Schlag nicht allein auf der Basisisolierung beruht, sondern die eine zusätzliche Sicherheitsvorkehrung derart enthält, dass berührbare leitfähige Teile mit Mitteln zum Anschluss an den Schutzleiter der festen Installation ausgerüstet sind, so dass im Fehlerfall der Basisisolierung berührbare leitfähige Teile nicht aktiv werden können.



Article no.: 730410

Surface mounted ceiling lamp, Mob Square II Anthracite, anthracite, 220-240V AC/50-60Hz, 9,00 W

Technical Data

General Characteristics

Material	aluminum die casting
Colour	anthracite
Optics	
included in delivery	



Electrical Characteristics

Power	9,00 W
Input voltage	220-240V AC/50-60Hz
Input current	
Base (standard designation)	GX53
Number of bases	1
Power supply unit	
Electronically reversible	not dimmable
Connection possibility	clamp
Protection class I, II, III	I





Article no.: 730410

Surface mounted ceiling lamp, Mob Square II Anthracite, anthracite, 220-240V AC/50-60Hz, 9,00 W

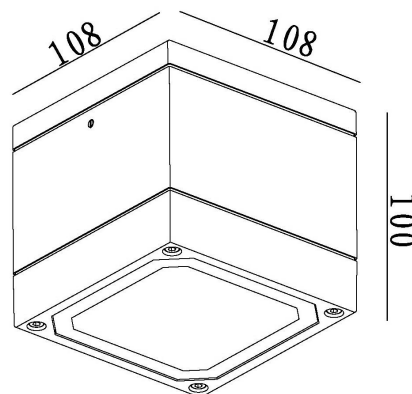

Light Direction

Rotating and tilting range	fixed
Angle of inclination	0°
Radiation direction	
Reflector / lense	

Dimensions & Weight

Length	108 mm
Width	108 mm
Height	100 mm
Diameter	
Suspensions from ceiling	
Product Weight	653 g

Base dimensions

Length	108 mm
Width	108 mm
Height	
Diameter	



Article no.: 730410

Surface mounted ceiling lamp, Mob Square II Anthracite, anthracite, 220-240V AC/50-60Hz, 9,00 W

Absolute maximum ratings

Working temperature	-20°C - +40°C
Storage temperature	-10°C - +60°C
IP - Code	IP 54

IP 54

Protection against penetration of dust. (dust protected) Protection against penetration of splashing water.



Lightings of Protection Class I in which the protection against electric shock is not based solely on isolation, but an additional safety measure contains such a way that accessible conductive parts are equipped with means for connection to the protective conductor of the fixed installation, so that in case of failure of the basic insulation exposed conductive parts cannot be active.