

Paul Neuhaus

Paul Neuhaus GmbH
Olakenweg 36 · D-59457 Werl

+49(0)2922 9721 0
+49(0)2922 9721 9120
info@neuhaus-group.de

<https://scm.paul-neuhaus.de/public/conformity/>



D | Montageanleitung • GB | Fitting instruction

DE Dieses Produkt enthält Lichtquellen der Energieeffizienzklasse <E>.

GB This product contains light sources of energy efficiency class <E>.

FR Ce produit comprend sources lumineuses de classe d'efficience énergétique <E>.

ES Este producto contiene fuentes de luz de la clase de eficiencia energética <E>.

HR Ovak proizvod sadrži izvori svjetlosti energetskeg razreda <E>.

HU Ez a termék <E> energiahatékonysági osztályba tartozó fényforrások tartalmaz.

IT Questo prodotto contiene una sorgente luminosa della classe di efficienza energetica <E>.

NL Dit product bevat lichtbronnen van energie-efficiëntieklasse <E>.

833354

230V/50Hz~

1x LED-Board 24V DC /17W

1x LED-Board 24V DC / 20W
nicht wechselbar / not changeable

2,4 GHz
10 dBm

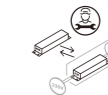

| | |
|----|-------------------|
| | 17 W / 20 W |
| | 2.040 / 2.400 lm |
| | 42 W |
| | 2.200 lm |
| | LED-Board |
| t | 25.000 h |
| Tk | 2.700-5.000 K |
| | 15.000 x |
| | < 0,5 s |
| | dimmable with rrc |



1 | Montage / fitting

als Deckenleuchte
as ceiling light

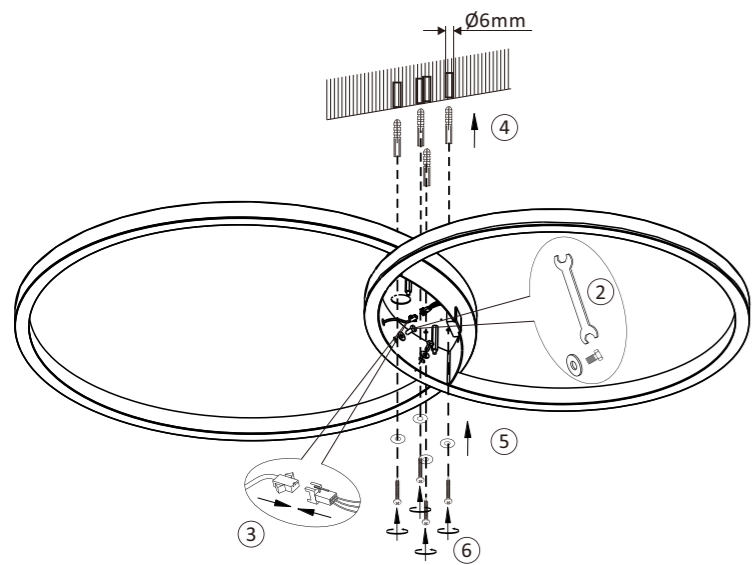

2 | Elektrischer Anschluss/ electrical connection

230Volt/50Hz-Anschluss
230 voltage/50 Hz connection

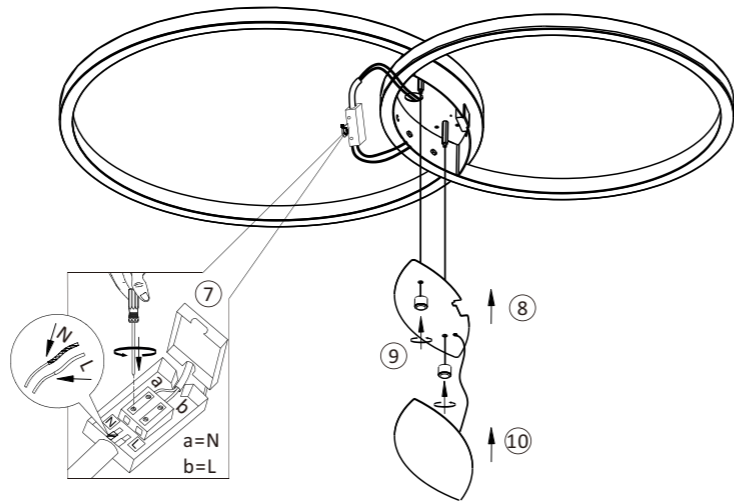

3 | Fernbedienung anlernen / teach remote control

Siehe Q-Fernbedienungsanleitung
See Q-remote control manual

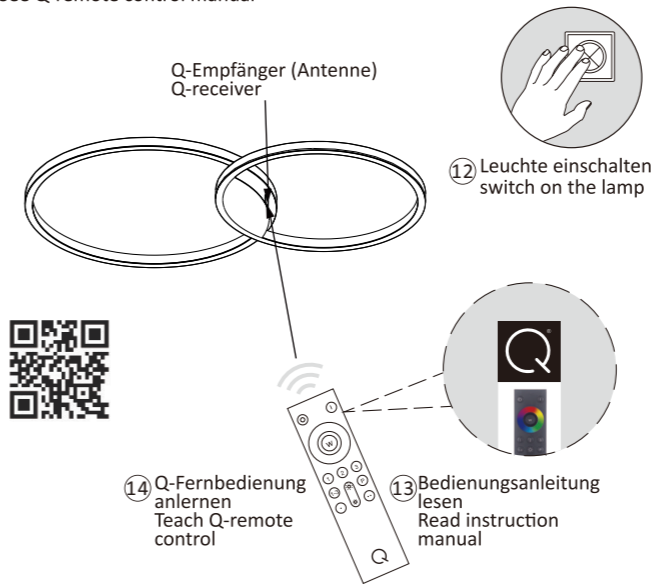

Reset

Rückstellen der Leuchte auf Werkseinstellung
Reset the lamp, factory new

5x on/off

