

Paul Neuhaus

Paul Neuhaus GmbH
Olakenweg 36 · D-59457 Werl

+49(0)2922 9721 0
+49(0)2922 9721 9120
info@neuhaus-group.de

<https://scm.paul-neuhaus.de/public/conformity/>



D | Montageanleitung • GB | Fitting instruction

- DE** Dieses Produkt enthält eine Lichtquelle der Energieeffizienzklasse <F>.
- GB** This product contains a light source of energy efficiency class <F>.
- FR** Ce produit comprend une source de lumière de classe d'efficacité énergétique <F>
- ES** Este producto contiene una fuente de luz de la clase de eficiencia energética <F>.
- HR** Ovaj proizvod sadrži izvor svjetlosti energetskog razreda <F>.
- HU** Ez a termék <F> energiahatékonysági osztályba tartozó fényforrást tartalmaz.
- IT** Questo prodotto contiene una sorgente luminosa della classe di efficienza energetica <F>.
- NL** Dit product bevat een lichtbron van energie-efficiëntieklasse <F>.

836653

230V/50Hz~
1x LED-Board 240V DC / 36W
nicht wechselbar / not changeable

2,4 GHz
4,79 dBm

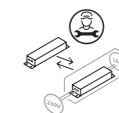
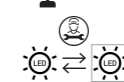

| | |
|-----------|---------------|
| LED | 36 W |
| | 3.720 lm |
| | 40 W |
| | 1.500 lm |
| | LED-Board |
| t | 25.000 h |
| Tk | 2.700-5.000 K |
| | 15.000 x |
| | < 0,5 s |



AAA, 1,5V

Inkl. IR-Fernbedienung
Incl. IR remote control



1 | Montage / fitting

als Deckenleuchte
as ceiling light

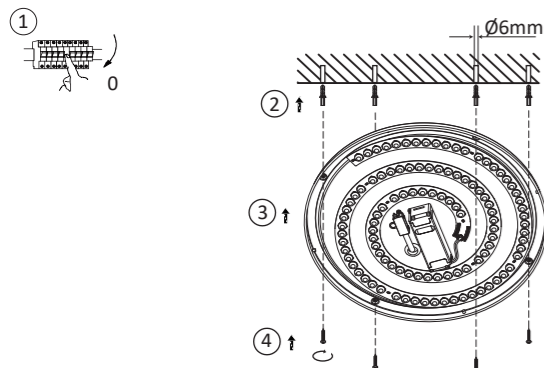

2 | Elektrischer Anschluss/ electrical connection

230Volt/50Hz-Anschluss
230 voltage/50 Hz connection

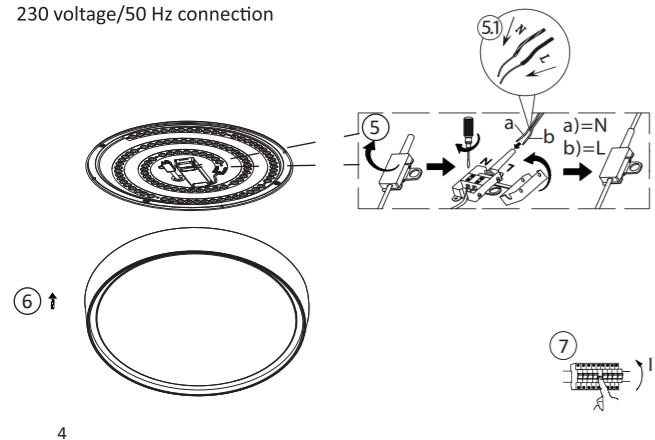

3 | Fernbedienung / remote control

Siehe Q-Fernbedienungsanleitung
See Q-remote control manual



Reset

Zur Einbindung in ein ZigBee Netzwerk, stellen Sie die Leuchte auf Werkseinstellungen zurück.

To integrate the lamp into a ZigBee network, reset the lamp to the factory setting.

5x on/off

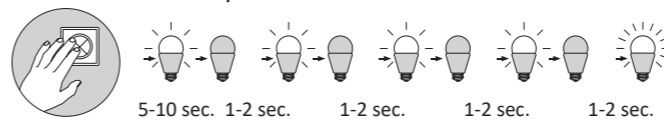

1 | Montage / fitting

als xxx
as xxx light

2 | Elektrischer Anschluss/ electrical connection

230Volt/50Hz-Anschluss
230 voltage/50 Hz connection

3 | Fernbedienung / remote control

Siehe Q-Fernbedienungsanleitung
See Q-remote control manual

Q-Empfänger
Q-receiver



Leuchte einschalten
switch on the lamp



Bedienungsanleitung
lesen
Read instruction
manual

Reset

Zur Einbindung in ein ZigBee Netzwerk, stellen Sie die Leuchte auf Werkseinstellungen zurück.

To integrate the lamp into a ZigBee network, reset the lamp to the factory setting.

5x on/off



5-10 sec. 1-2 sec. 1-2 sec. 1-2 sec. 1-2 sec.