



Assembly Instructions

ELEMENTS/PARTS	Ax5  (spare 1)	Bx5  (spare 1)	Cx1 
----------------	-------------------------------------------------------------------------------------------------------	---------------------------------------------------------------------------------------------------------	--------------------------------------------------------------------------------------------



ASSEMBLY INSTRUCTIONS MONTAGEANLEITUNGEN

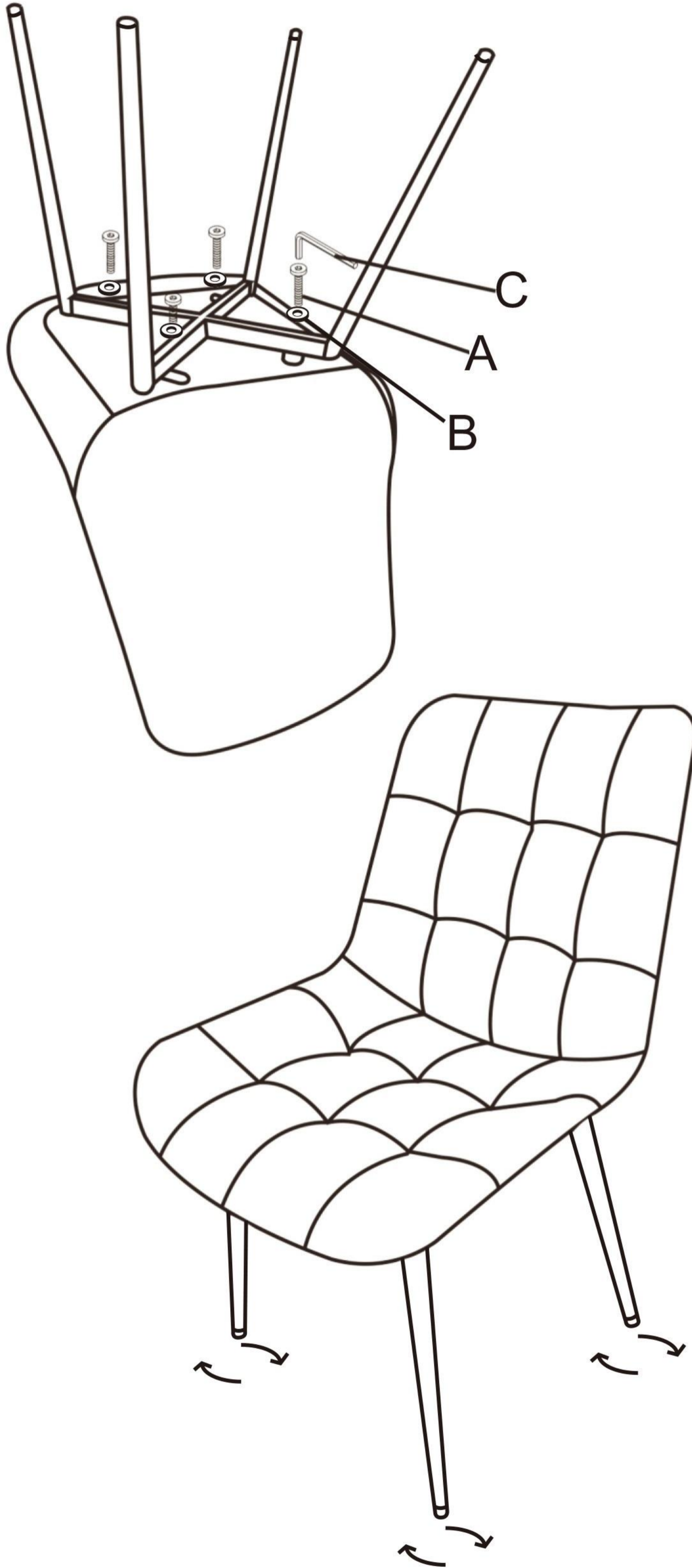

WF322339/WF322340

Our product will be delivered to you in 2 packages. The delivery times of these 2 packages may differ, please be patient and thank you for your understanding.

Unser Produkt wird Ihnen in 2 Paketen geliefert. Die Lieferzeiten dieser 2 Pakete können abweichen, bitte haben Sie etwas Geduld und vielen Dank für Ihr Verständnis.

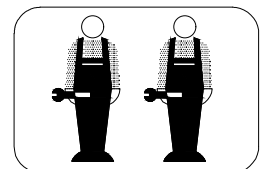
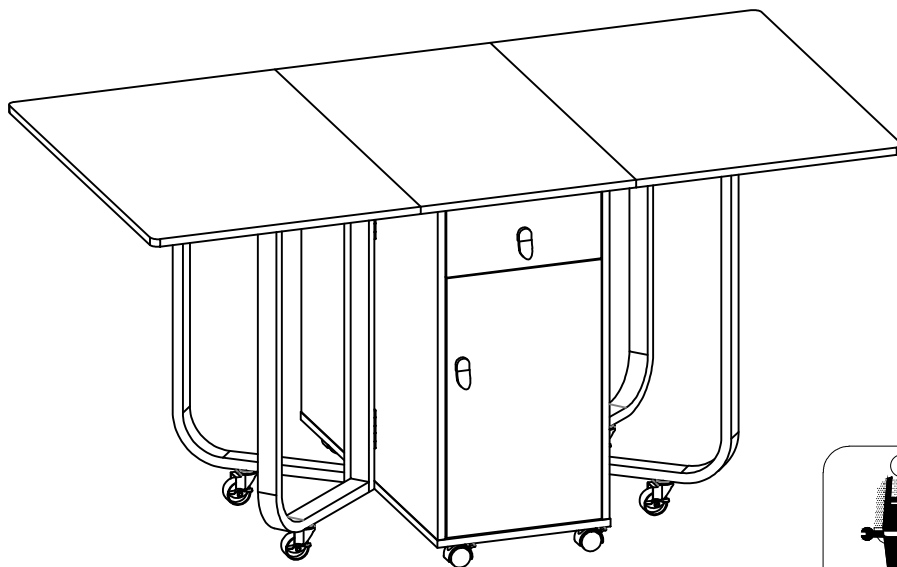
Nos produits vous seront livrés en deux colis. Les délais de livraison peuvent être différents pour les deux colis, veuillez patienter et vous remercier de votre compréhension.



 Ø15×12mm	 Ø15×10mm
Ⓑ×14pcs	Ⓒ×8pcs

Bitte beachten Sie, dass die Formen der Schrauben B und C ähnlich sind. Bitte installieren Sie entsprechend der Anleitung und unterscheiden Sie sie!

Please note that the shapes of screws B and C are similar. Please install according to the instructions and distinguish them!

Notez que les vis B et C ont des formes similaires. Veuillez les installer en suivant les instructions pour les séparer!







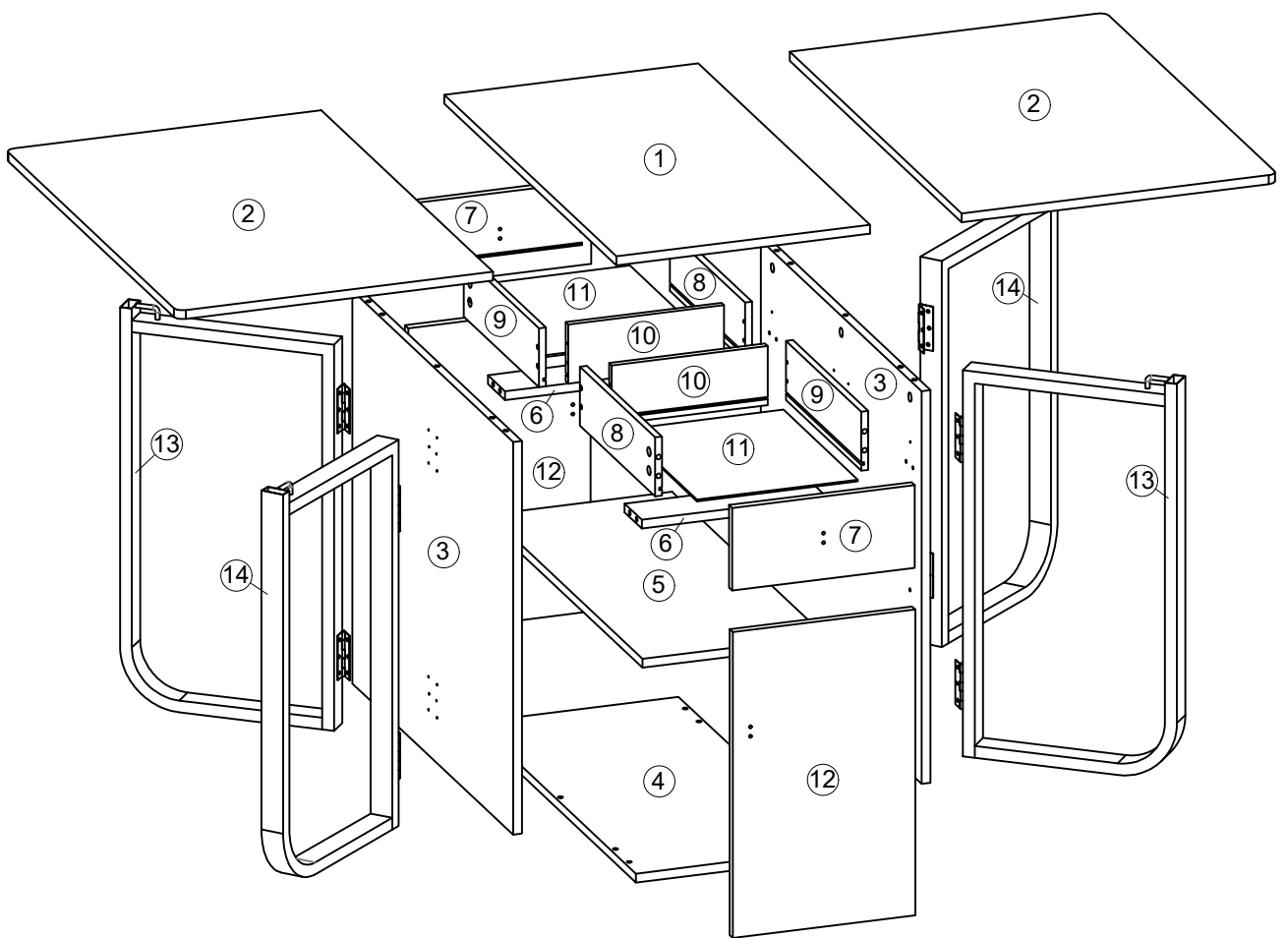

Vor dem Einbau die Schrauben in die Löcher stecken und festziehen, aber nicht bis 100%, 70% bis 80% anziehen reicht aus. Schließlich, nachdem alle Schrauben installiert sind, ziehen Sie alle Schrauben auf 100%. Wenn Sie auf diese Probleme stoßen, z.B. wenn die Löcher nicht ausgerichtet werden können oder einige Teile nicht installiert werden können, überprüfen Sie bitte, ob die Schrauben korrekt verwendet werden und passen Sie die Dichtigkeit der Schrauben an.

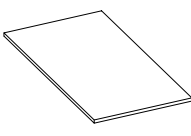
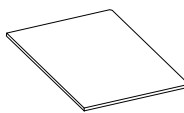
Before installation, insert the screws into the holes and tighten them, but do not tighten them to 100%, 70% to 80% is sufficient. Finally, after all screws are installed, tighten all screws to 100%. If you encounter these issues, such as if the holes cannot be aligned or some parts cannot be installed, please check if the screws are used correctly and adjust the tightness of the screws.

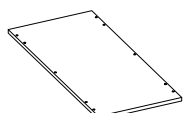
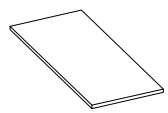
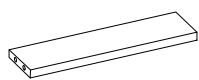
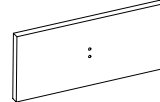
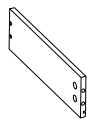
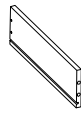

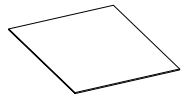







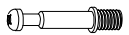

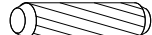

Insérer la vis dans le trou avant la fin de l'assemblage, serrer la vis, mais ne pas serrer à 100%, 70% ~ 80% est correct. Enfin, une fois que toutes les vis sont bien serrées, toutes les vis sont serrées à 100%. Si vous rencontrez ces problèmes, par exemple si les trous ne sont pas alignés ou si certaines pièces ne peuvent pas être montées, vérifiez que les vis sont utilisées correctement et Ajustez leur serrage.

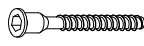

Part List Stückliste

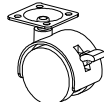
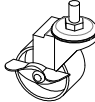
				
① ×1pc	② ×2pcs	③ ×2pcs	④ ×1pc	⑤ ×1pc
				
⑥ ×2pcs	⑦ ×2pcs	⑧ ×2pcs	⑨ ×2pcs	⑩ ×2pcs
				
⑪ ×2pcs	⑫ ×2pcs	⑬ ×2pcs	⑭ ×2pcs	

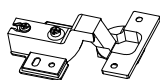
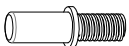
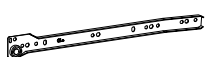
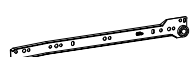
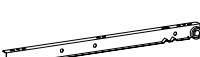
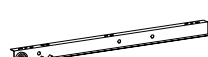
Hardware List Hardwareliste

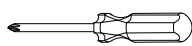
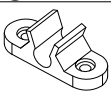
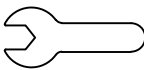
				
Ø6×35mm	Ø15×12mm	Ø15×10mm	Ø8×30mm	4×35mm
Ⓐ ×22pcs	Ⓑ ×14pcs	Ⓒ ×8pcs	Ⓓ ×8pcs	Ⓔ ×8pcs
				
3.5×14mm	4×12mm		4×18mm	Ø7×40mm
Ⓕ ×64pcs	Ⓖ ×48pcs	Ⓗ ×4pcs	Ⓘ ×8pcs	Ⓝ ×6pc
				
Ⓚ ×2pcs	Ⓛ ×2pcs	Ⓜ ×4pcs	Ⓝ ×4pcs	Ⓞ ×4pcs
				
Ø5×22mm				
Ⓟ ×4pcs	ⒸⓁ ×2pcs	ⒸⓇ ×2pcs	ⒹⓁ ×2pcs	ⒹⓇ ×2pcs
				
Ⓡ ×1pc	Ⓡ ×1pc	43×15×15mm Ⓡ ×4pcs	Ⓡ ×1pc	

Step 1
Schritt 1

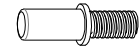

Ø5×22mm

Ⓟ×4pcs

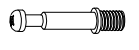

Ø6×35mm

Ⓐ×22pcs

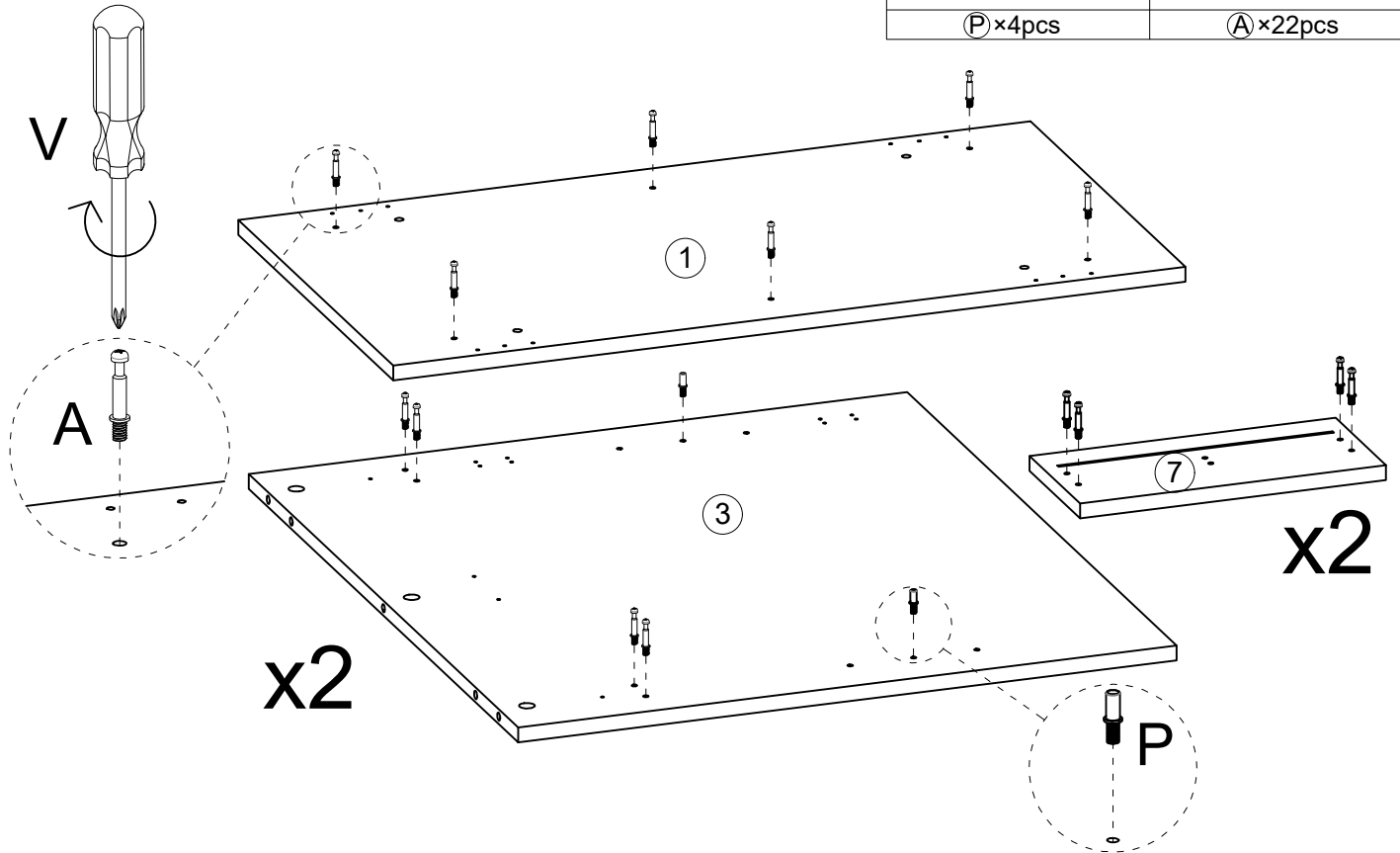

Step 2
Schritt 2

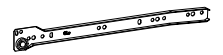
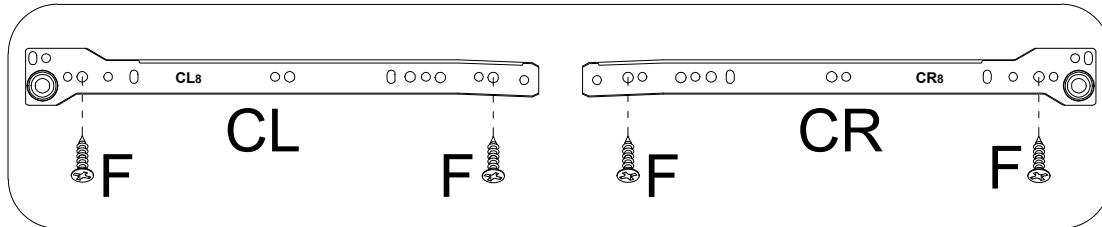

ⒸL×2pcs

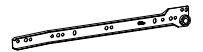

ⒸR×2pcs



3.5×14mm

ⓕ×8pcs

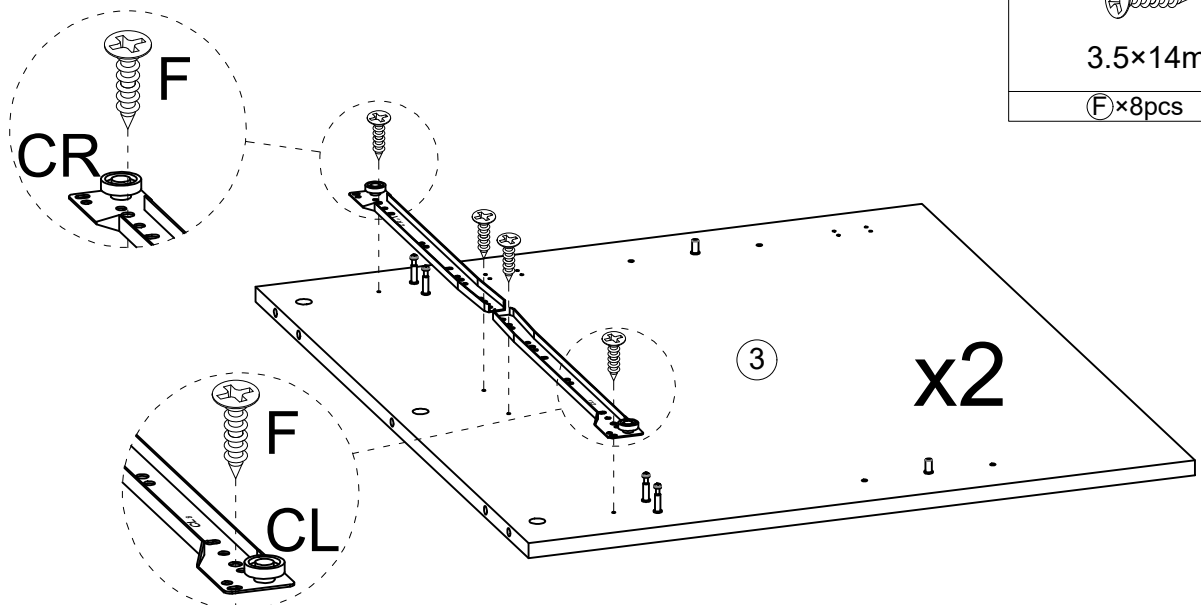

Step 3 Schritt 3

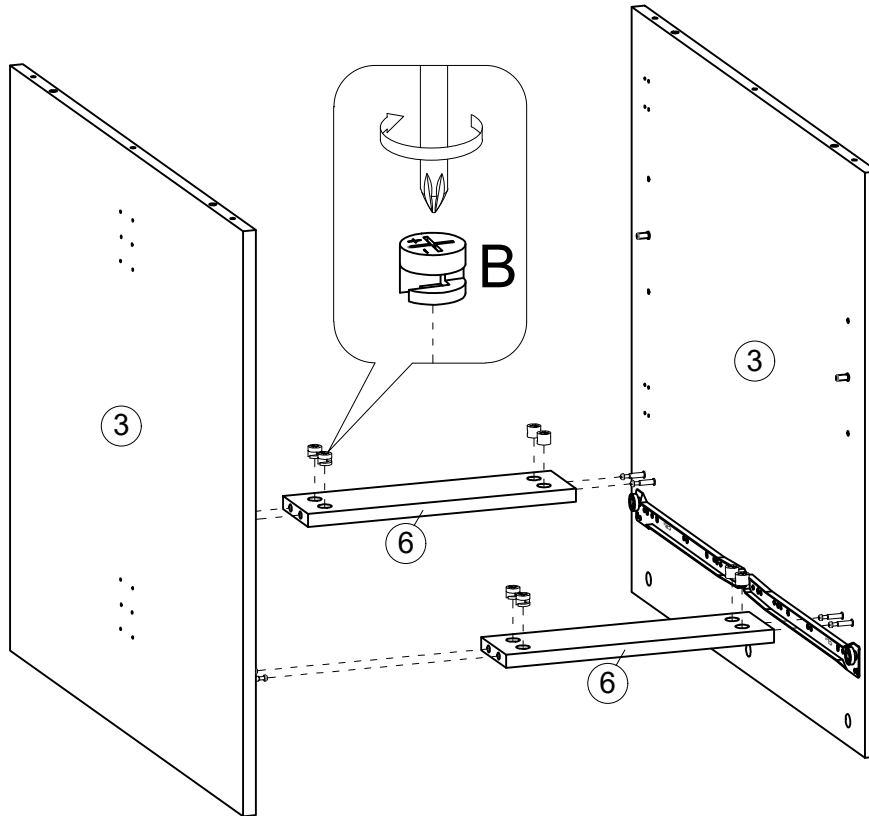

Ø15×12mm

ⓑ×8pcs



Ø15*12



Ø15*10

Step 4 Schritt 4

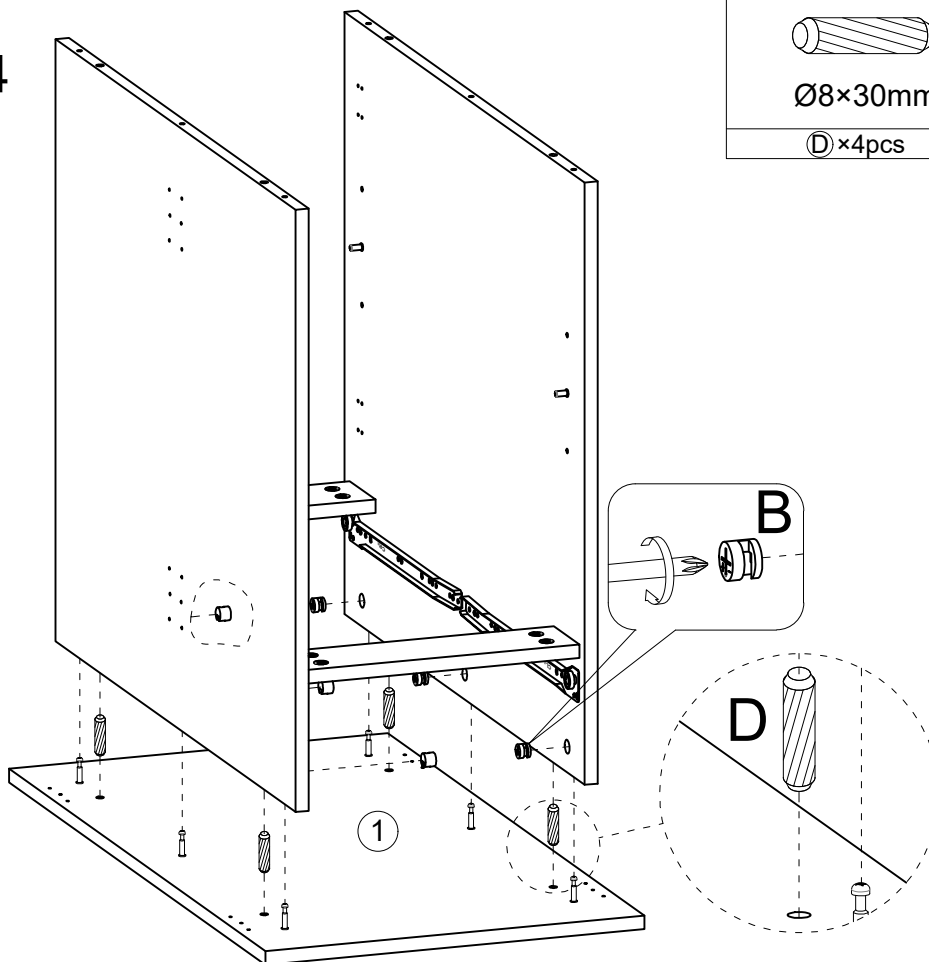

Ø8×30mm

ⓓ×4pcs



Ø15×12mm

ⓑ×6pcs



Ø15*12



Ø15*10

Step 5
Schritt 5

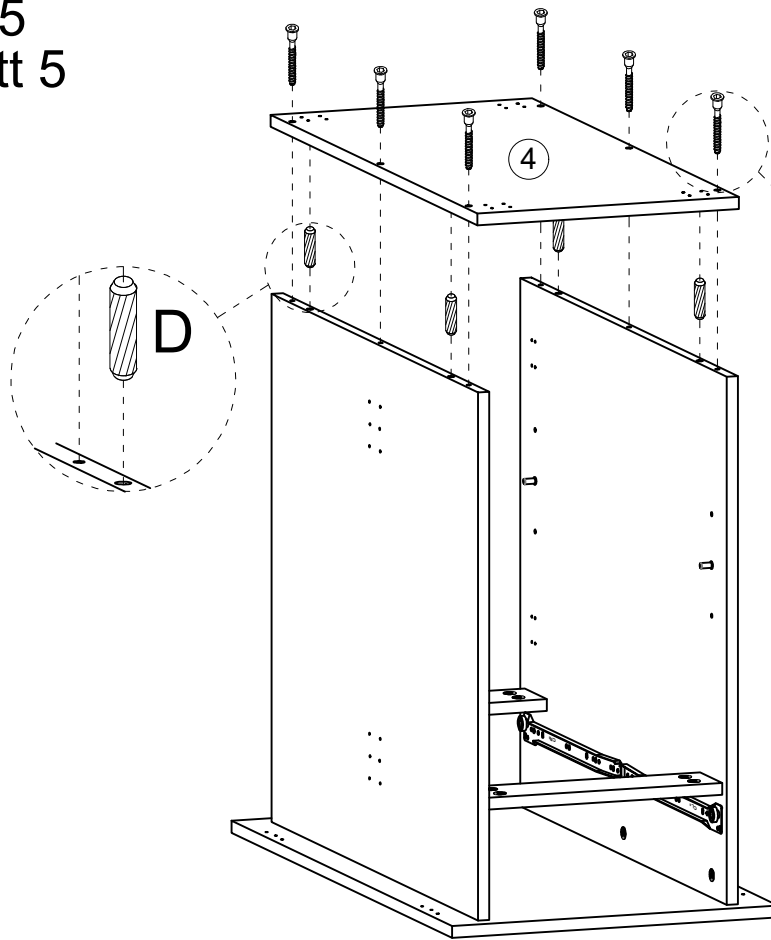

Ø8×30mm

D ×4pcs



Ø7×40mm

J ×6pc



D



J

Step 6
Schritt 6

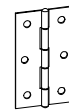
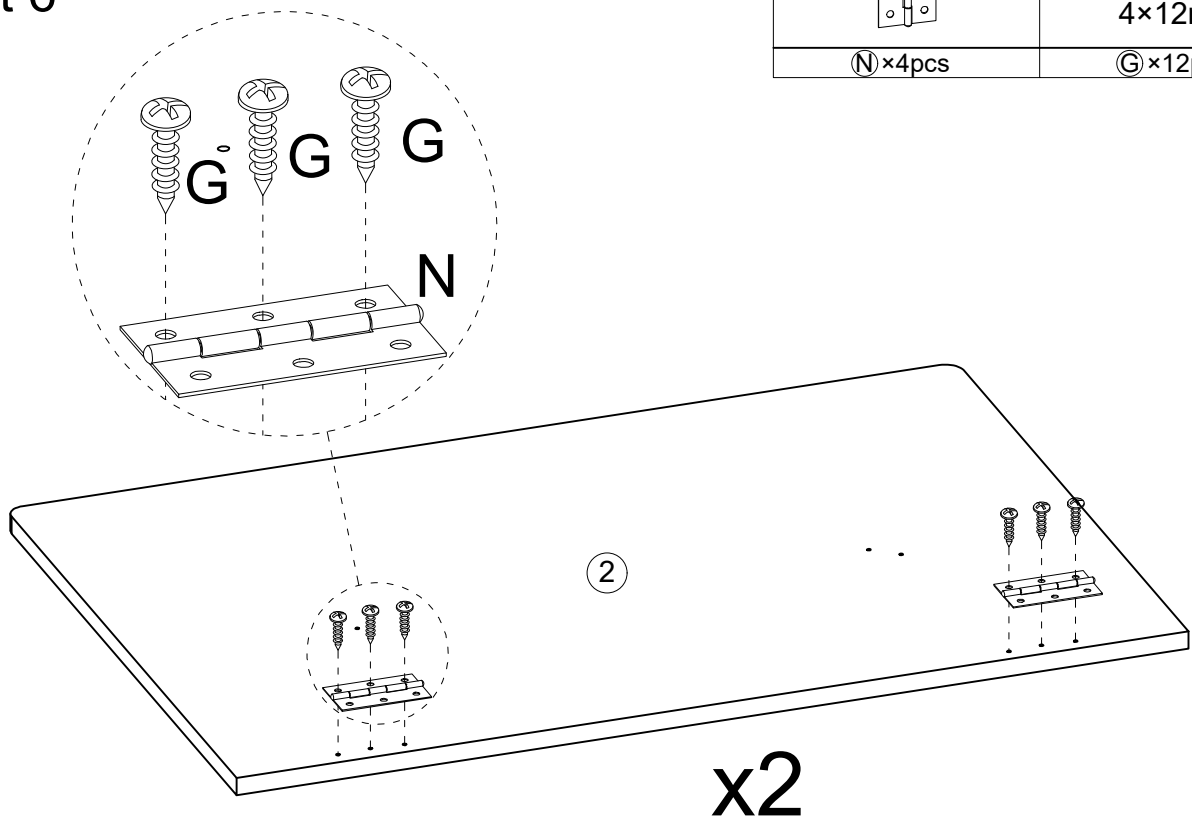

N ×4pcs



4×12mm

G ×12pcs

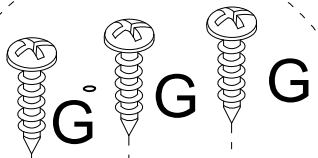

G

G

G

N

2

x2

Step 7
Schritt 7



3.5×14mm

F×8pcs

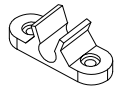

43×15×15mm

W×4pcs

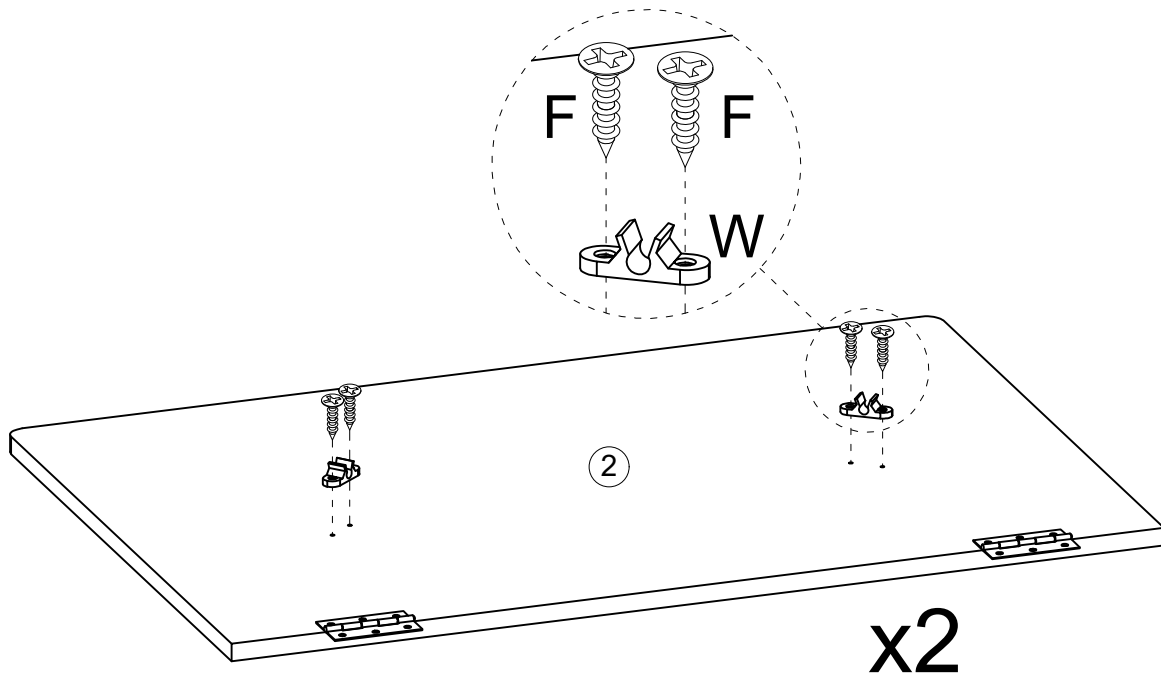

Step 8
Schritt 8



4×12mm

G×6pcs

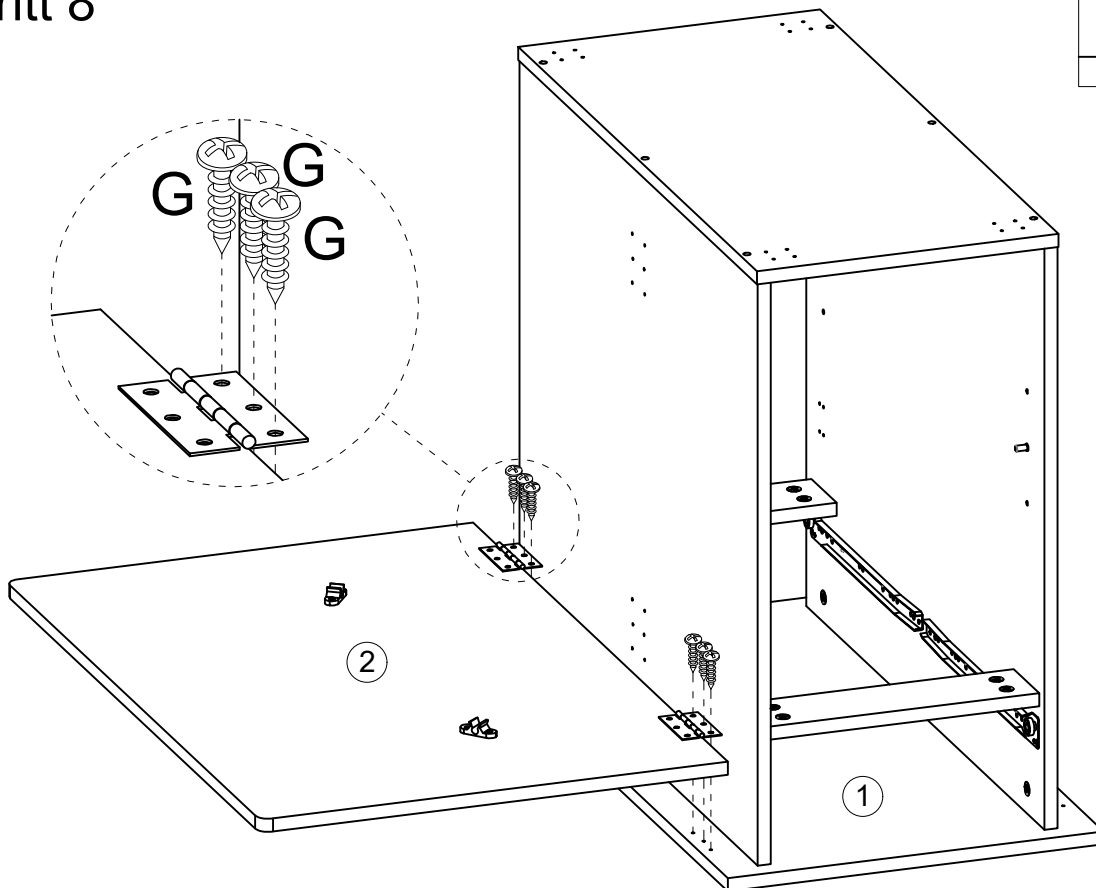

Step 9
Schritt 9



4×12mm

ⓐ ×6pcs

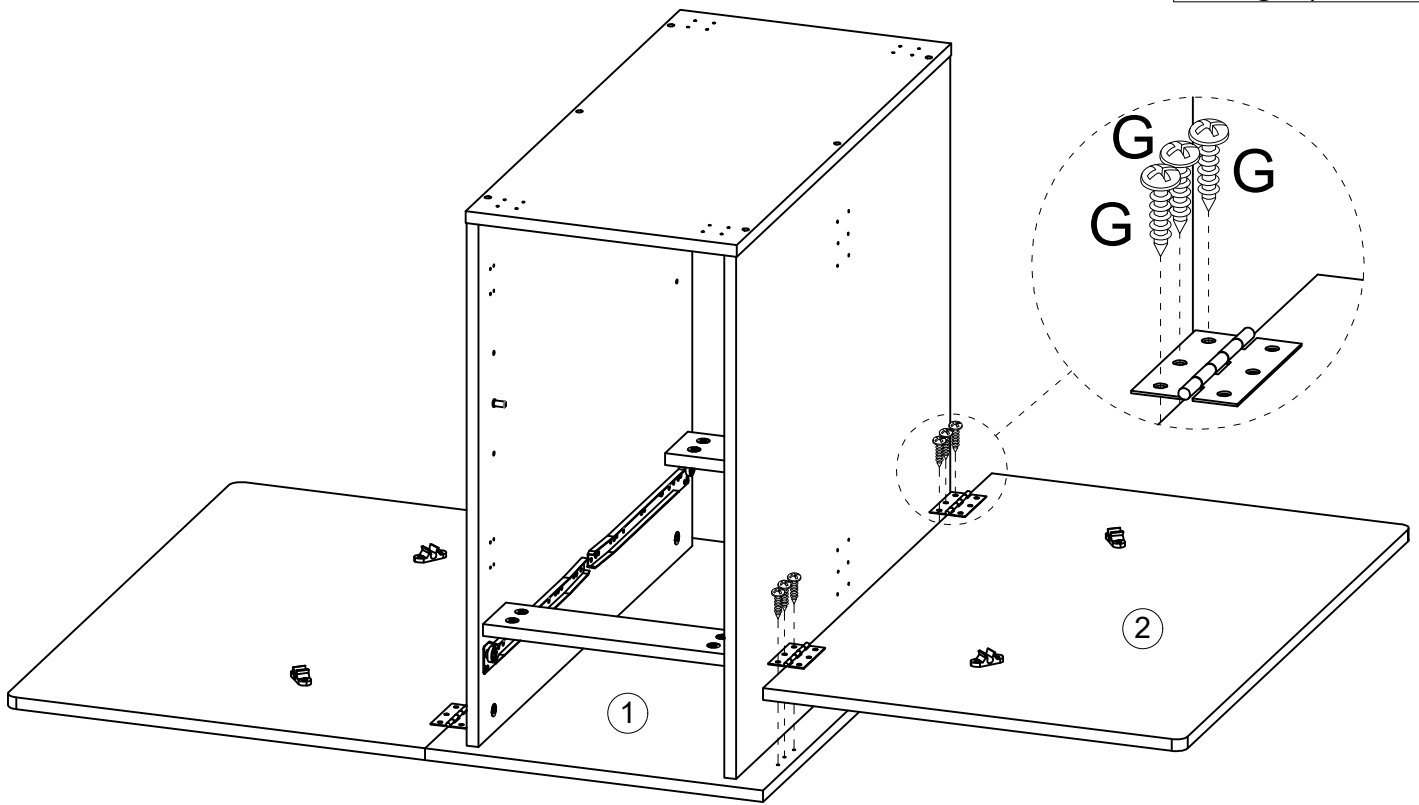

Step 10
Schritt 10



4×12mm

ⓐ ×12pcs

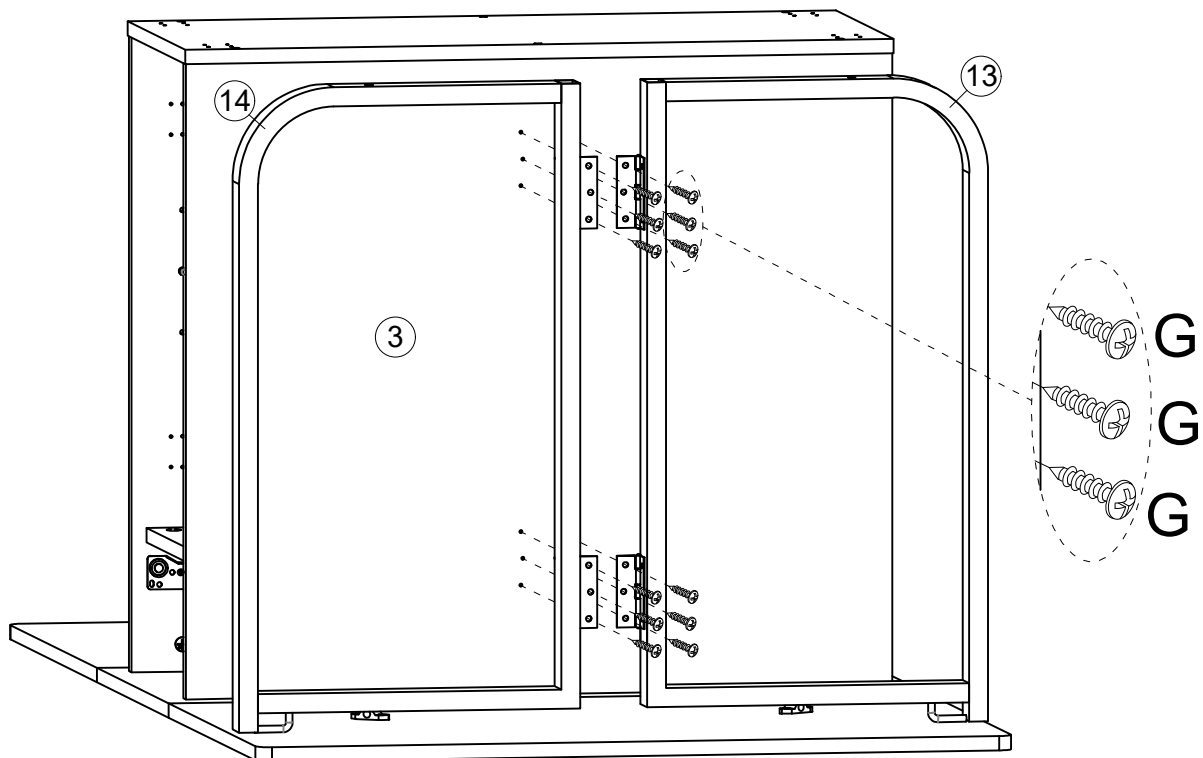

Step 11 Schritt 11



4×12mm

ⓐ×12pcs

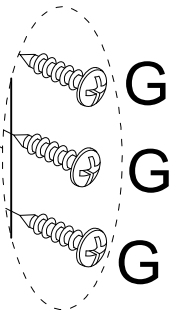
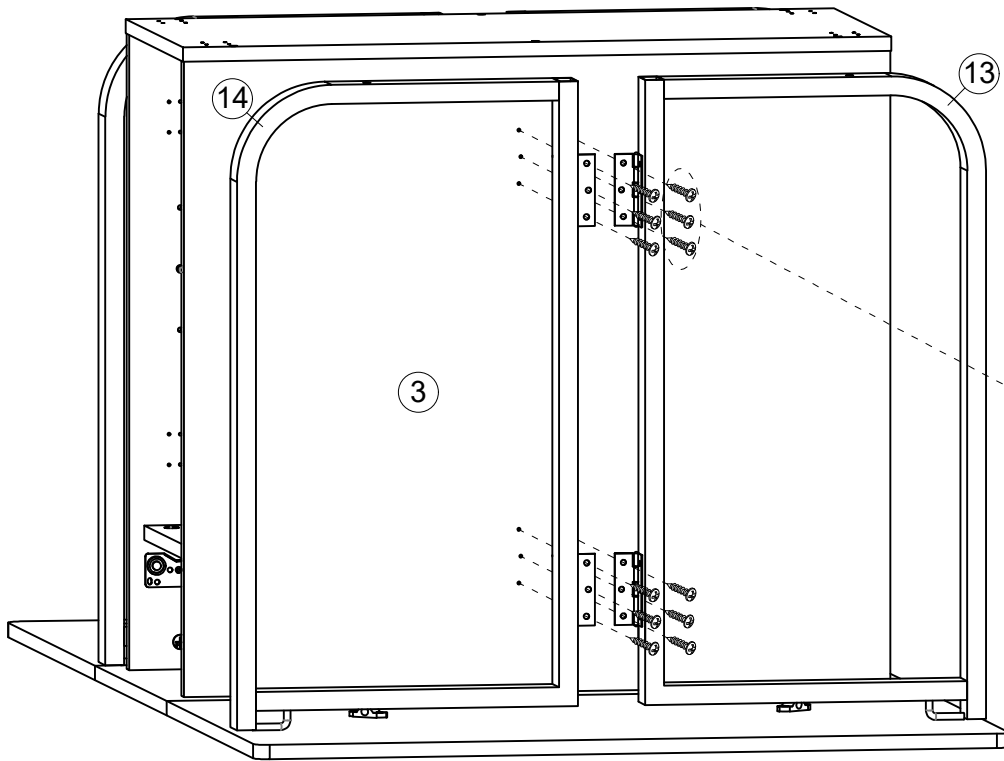

Step 12 Schritt 12

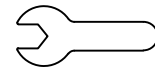

ⓧ×1pc



3.5×14mm

ⓕ×16pcs

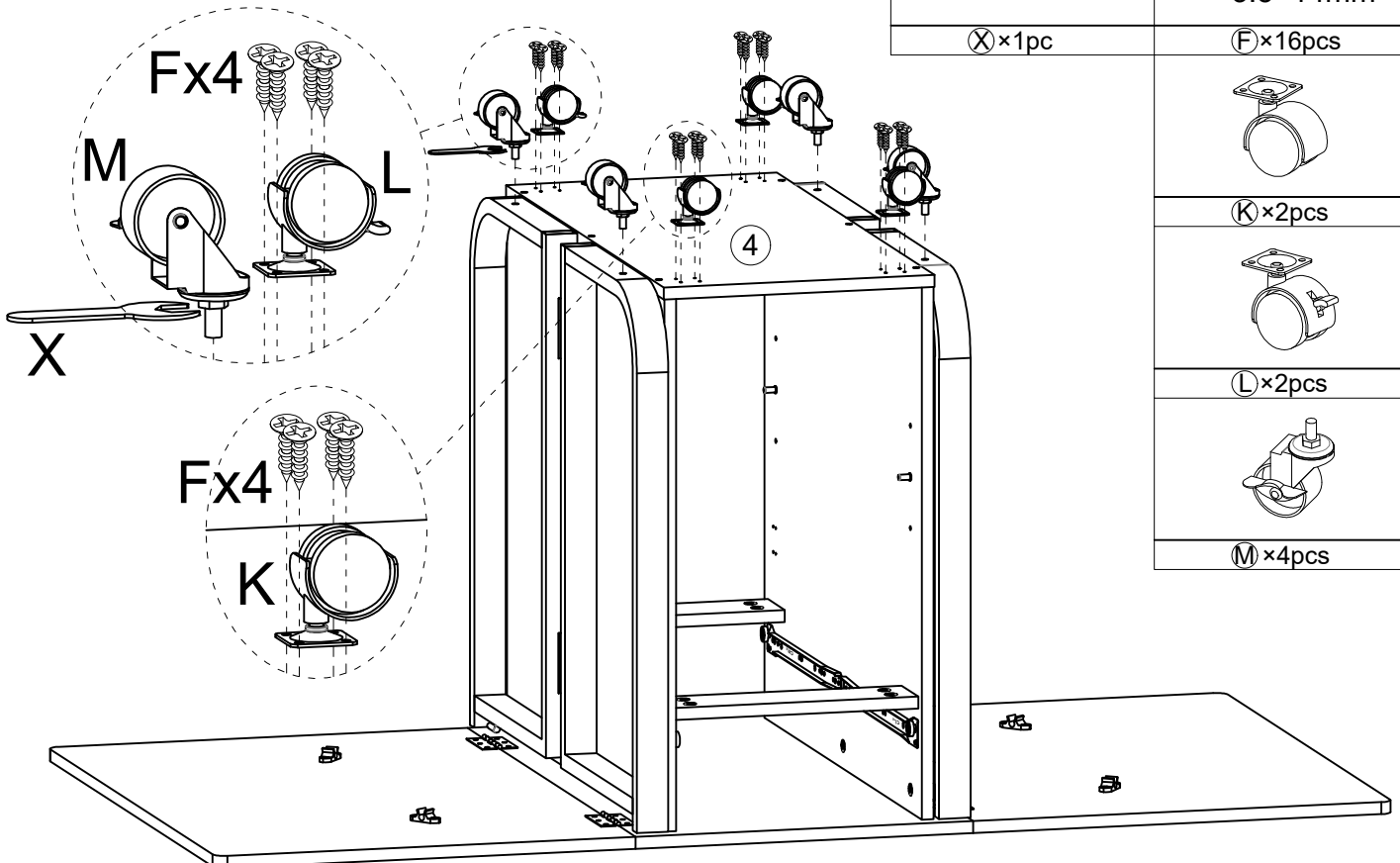

Ⓚ×2pcs

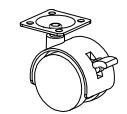

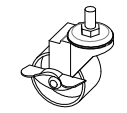

Ⓛ×2pcs

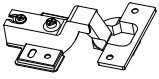

Ⓜ×4pcs

Step 13 Schritt 13

 3.5×14mm	 ○×4pcs	 H×4pcs	 4×18mm
F×8pcs			I×8pcs

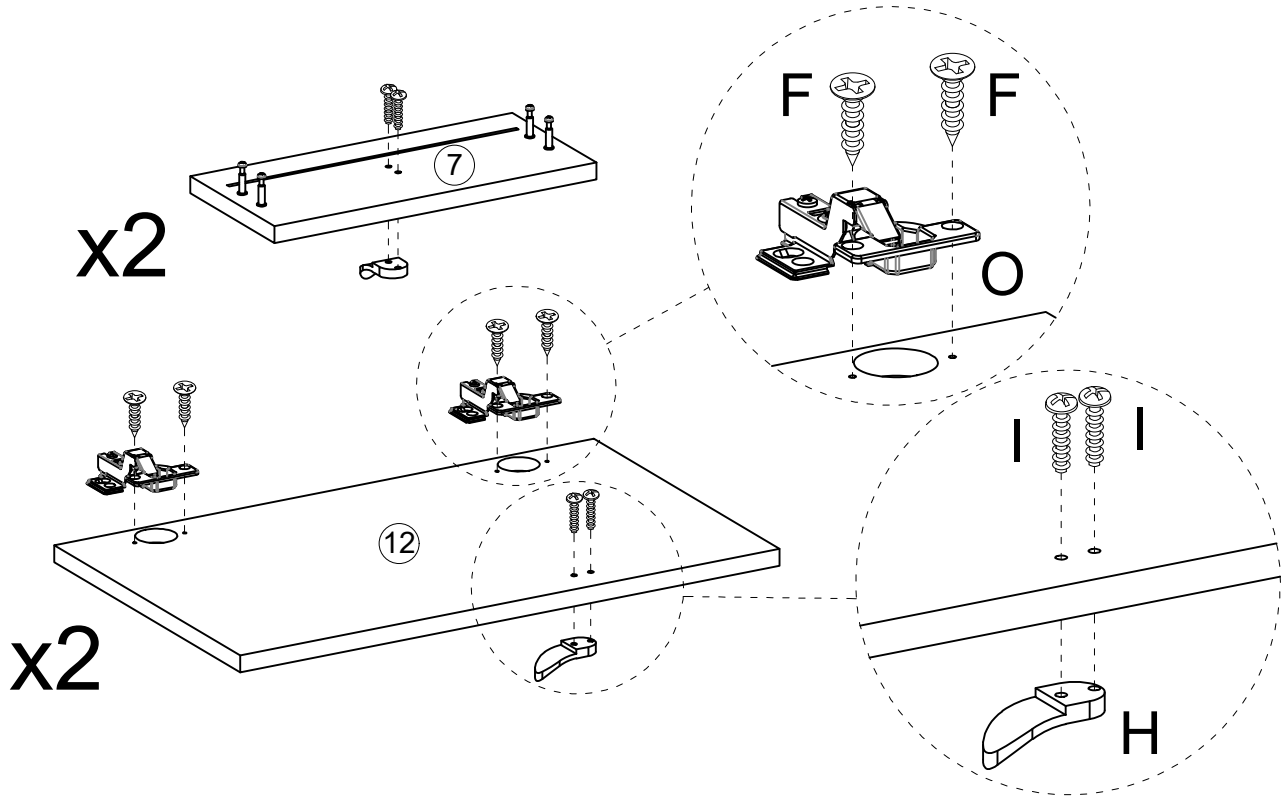

Step 14 Schritt 14

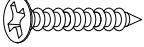
 Ø15×10mm	 4×35mm
C×8pcs	E×8pcs

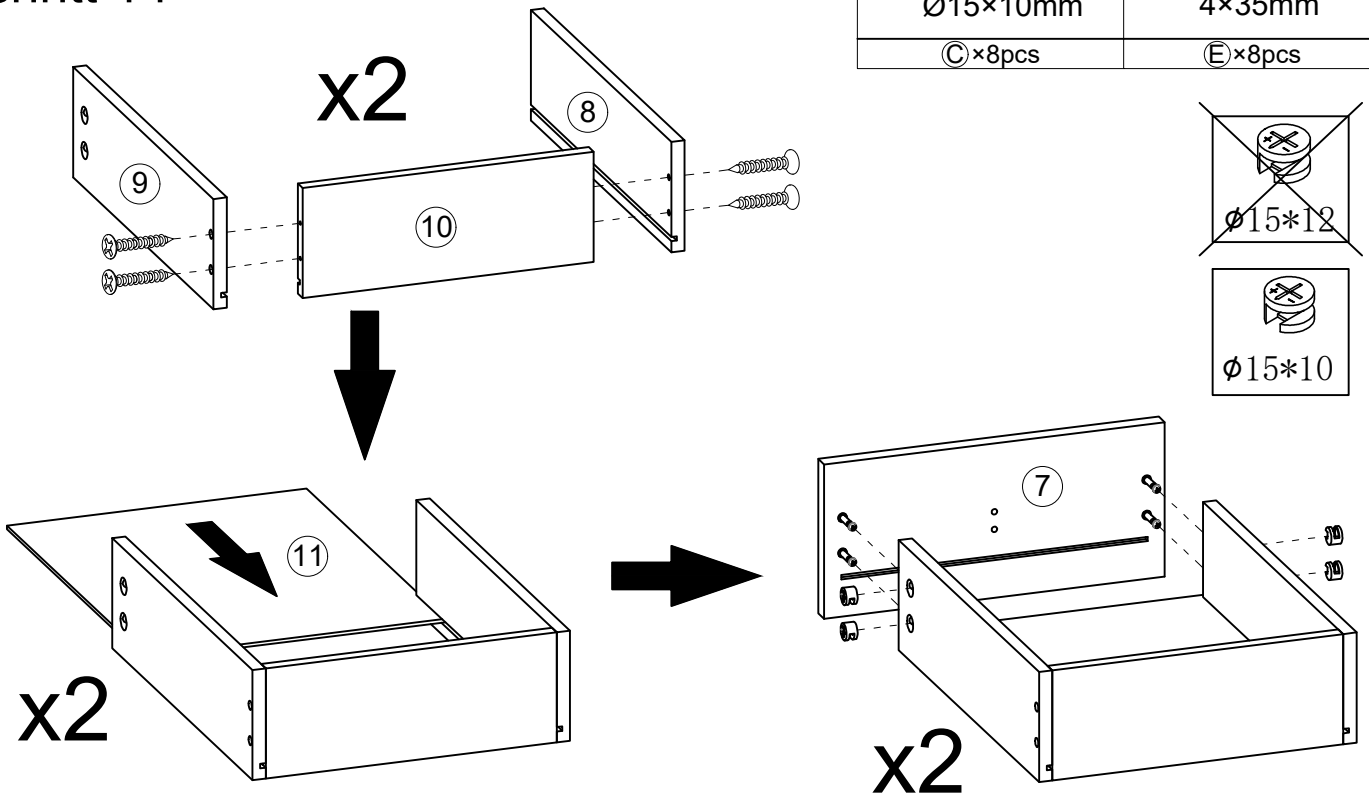

Step 15 Schritt 15



3.5×14mm

F×8pcs

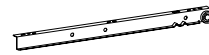

DL×2pcs

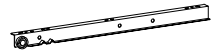

DR×2pcs

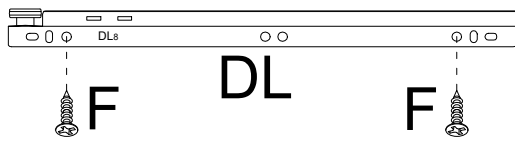

DL

F

F

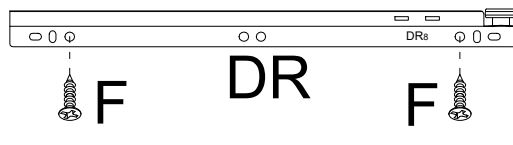

DR

F

F

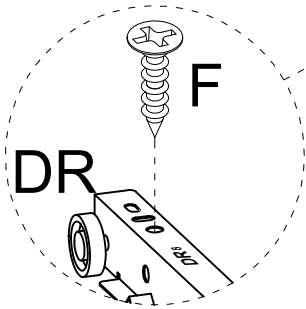

DR

F

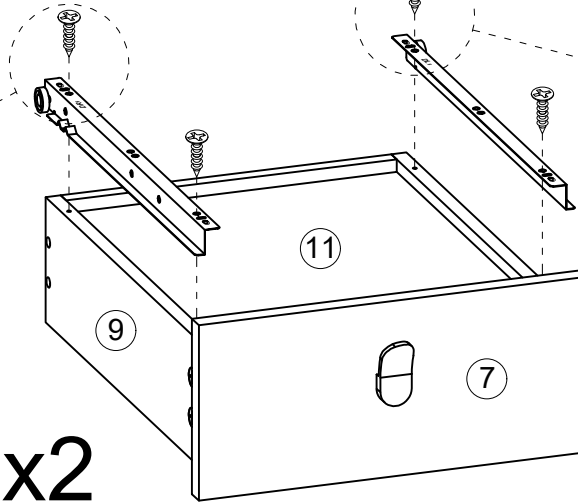

11

9

7

x2

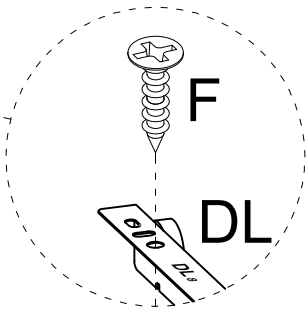

F

DL

Step 16 Schritt 16

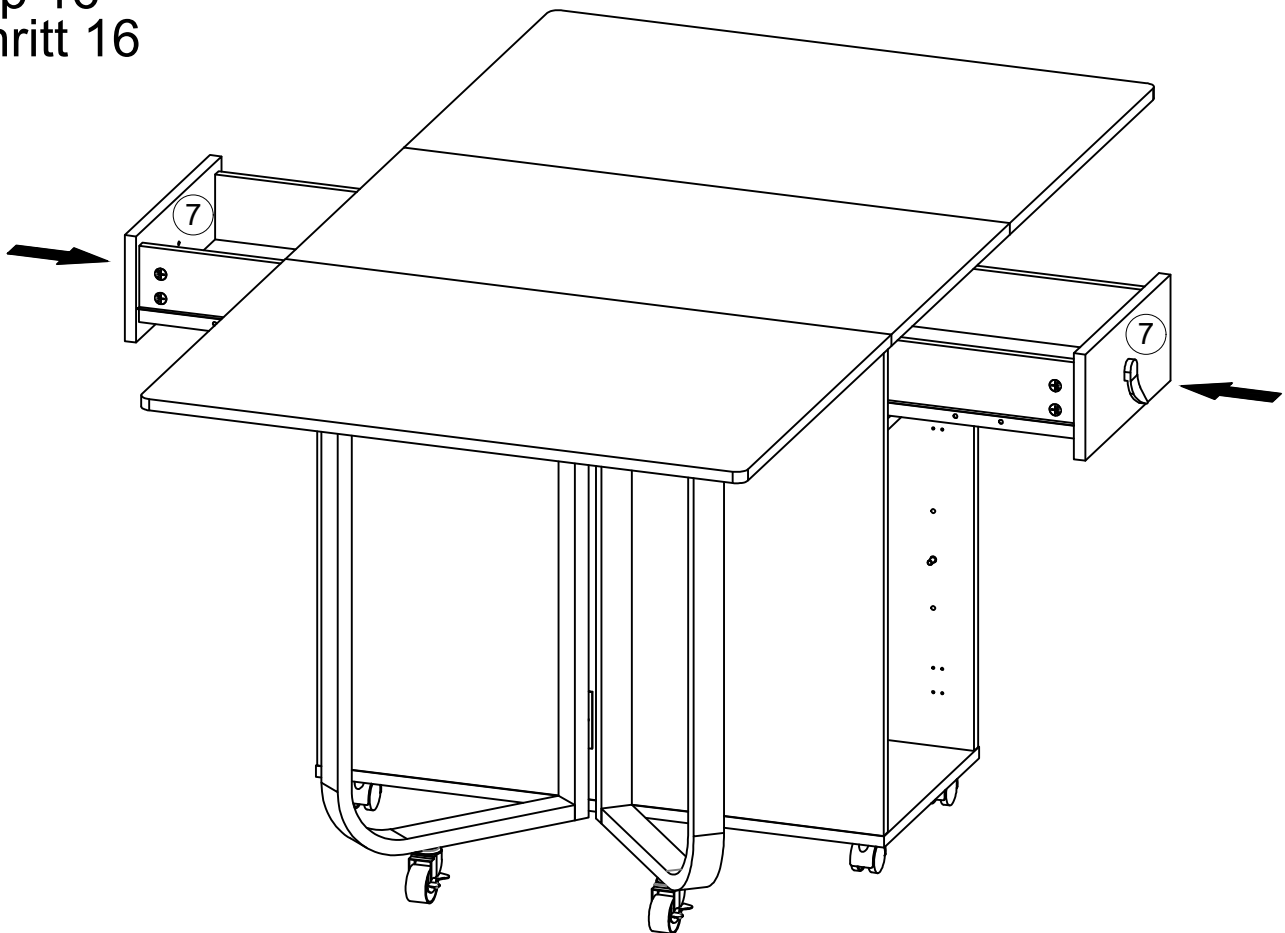

Step 17
Schritt 17



3.5×14mm

(F)×8pcs

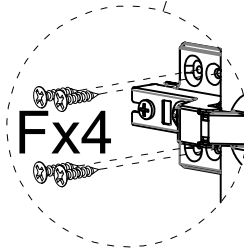
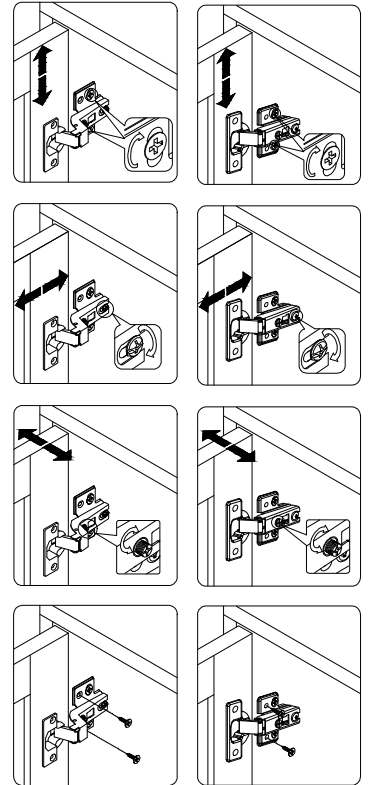
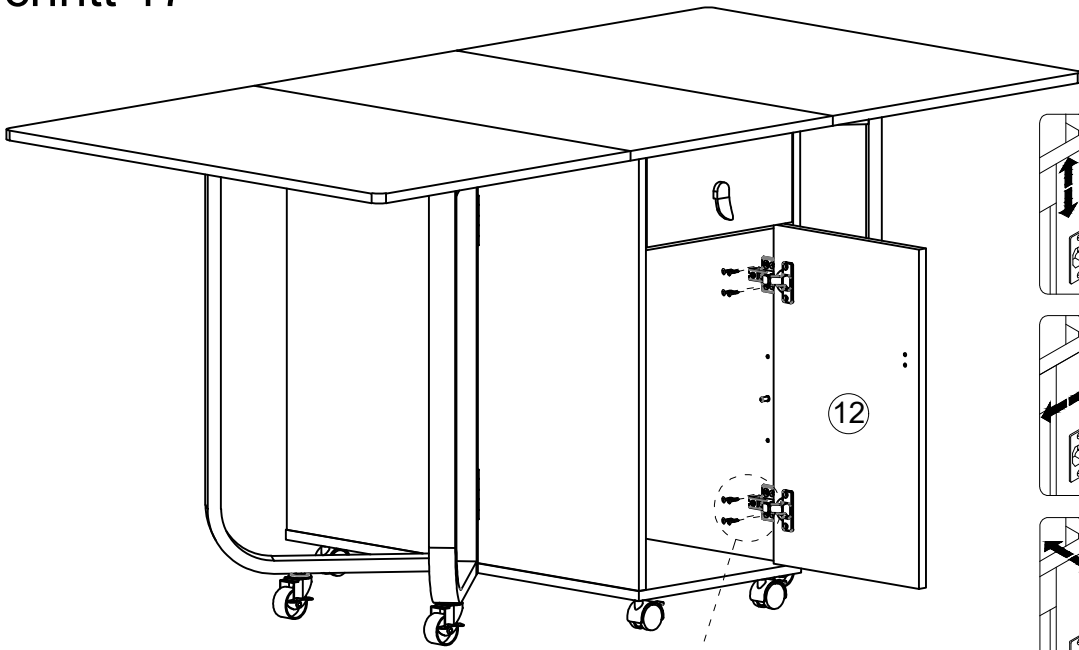

Step 18
Schritt 18

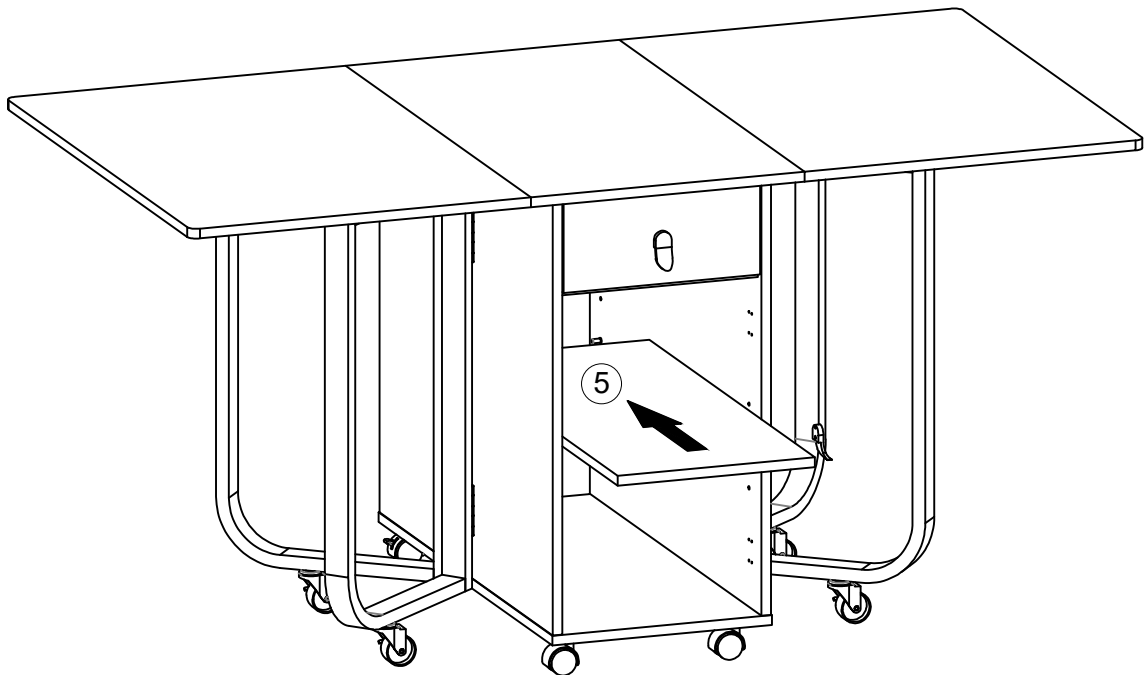

Step 19
Schritt 19



3.5×14mm

(F)×8pcs

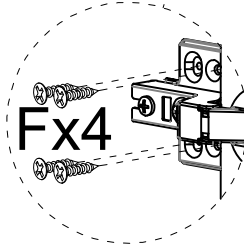
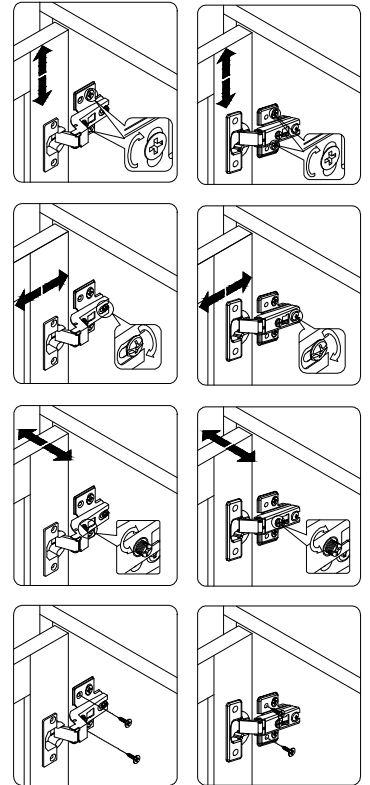
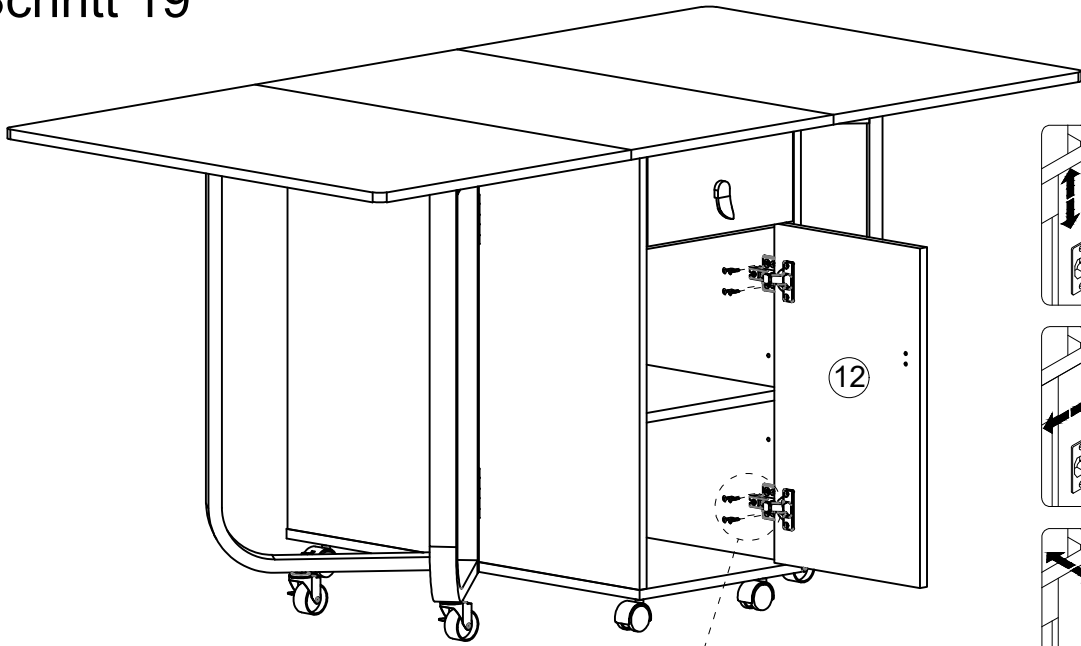

Step 20
Schritt 20

