



Olantern Music Light and Stereo Two-in-One Classic Camping Light

CONTENTS

Table listing contents for various languages: (EN) English, (CN) Chinese, (NO) Norwegian, (SV) Swedish, (NL) Nederlands, (PL) Polska, (DE) Deutsch, (HU) Magyarországi, (RU) Русский, (ES) Español, (RO) Română, (UA) Ukrainian, (JP) 日本語, (KR) 한국어, (TH) ไทย, (FR) Français, (IT) Italiano, (SK) Slovensky, (PT) Português.

IN THE BOX: Includes the Baton 2 flashlight, USB-Charging Cable, and a list of accessories like the lanyard and manual.

SPECIFICATIONS: Lists technical details such as High Light Mode (300 lumens), Low Light Mode (10 lumens), and battery life (up to 20 hours).

STEREO PARAMETERS

Table with columns for Features (Speaker output power, Signal-to-noise ratio, etc.) and Parameters (12W ±2, >81dB, etc.).

BLUETOOTH PARAMETERS

Table with columns for Features (Bluetooth version, Bluetooth transmitter power, etc.) and Parameters (V5.3, 1168m, etc.).

CHARGING

Power Bank set up: Instructions on how to connect the power bank to the flashlight and ensure it is fully charged.

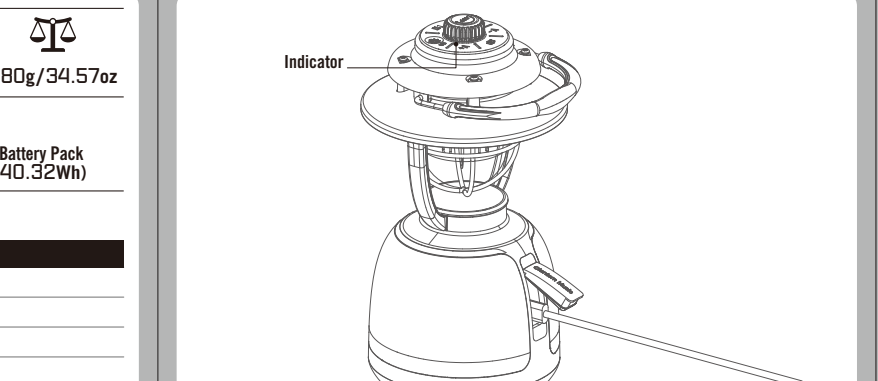

POWER BANK FUNCTION

Build-in with a 1120mAh battery pack consisting of 4-Li-ion batteries. It can charge phones and other digital devices.

CHARGING

Power Bank set up: Instructions on how to connect the power bank to the flashlight and ensure it is fully charged.

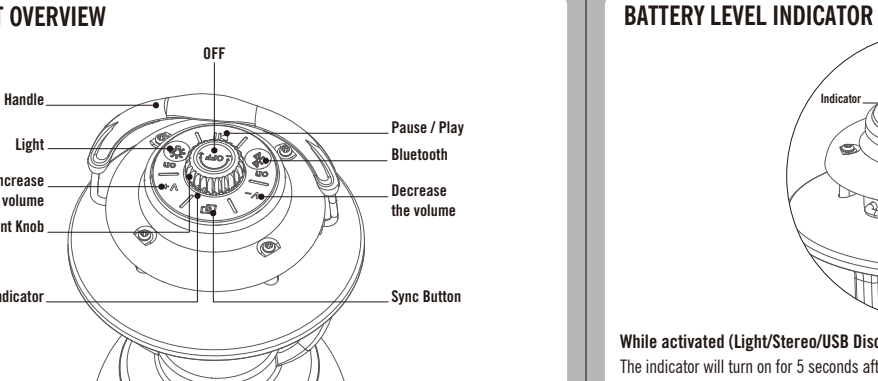
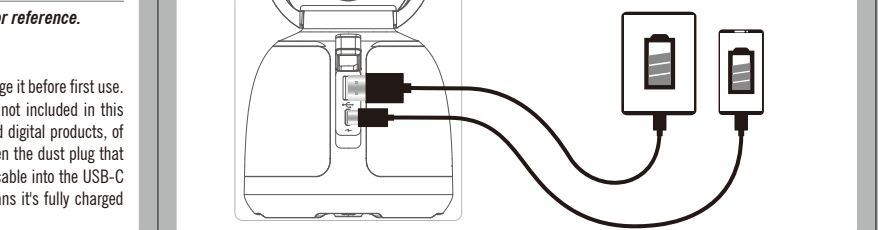

PRODUCT OVERVIEW

Build-in with a 1120mAh battery pack consisting of 4-Li-ion batteries. It can charge phones and other digital devices.

CHARGING

Power Bank set up: Instructions on how to connect the power bank to the flashlight and ensure it is fully charged.

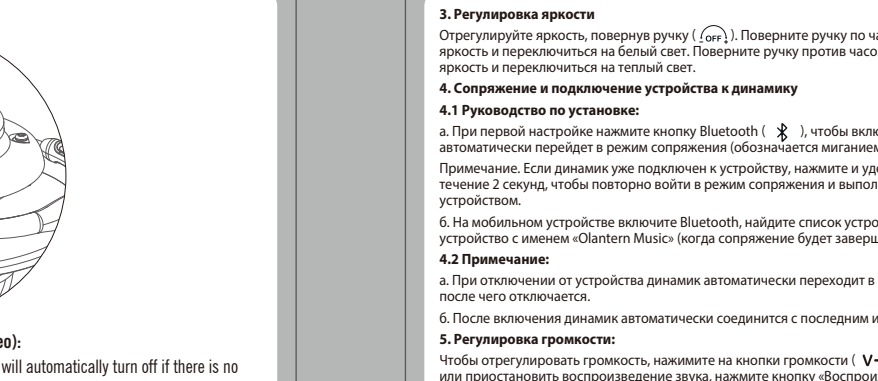

BATTERY LEVEL INDICATOR

The indicator displays the remaining battery level and turns off 5 minutes after charging begins.

CHARGING

Power Bank set up: Instructions on how to connect the power bank to the flashlight and ensure it is fully charged.

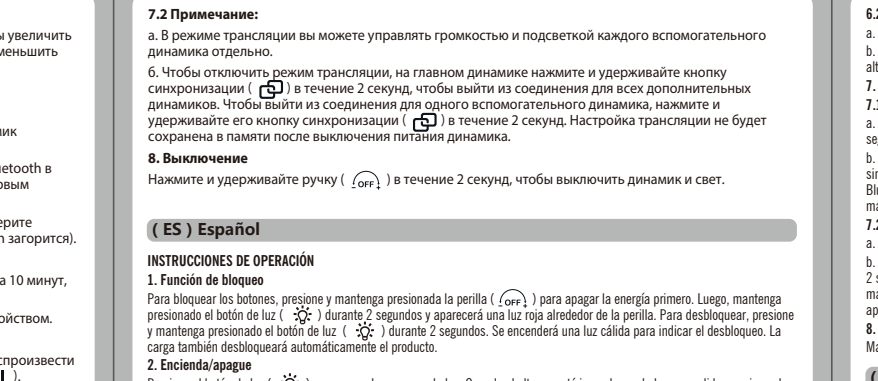
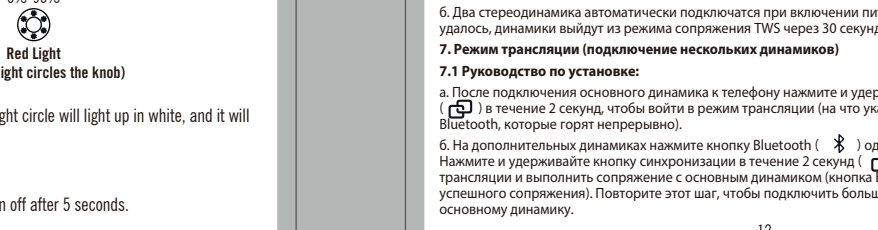

BATTERY LEVEL INDICATOR

The indicator displays the remaining battery level and turns off 5 minutes after charging begins.

CHARGING

Power Bank set up: Instructions on how to connect the power bank to the flashlight and ensure it is fully charged.

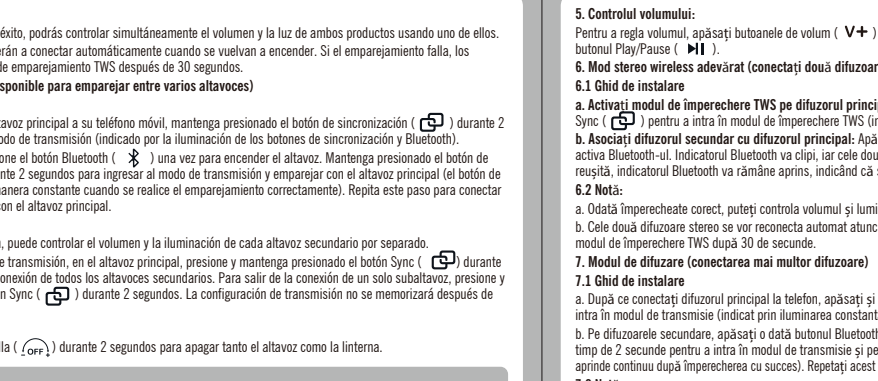
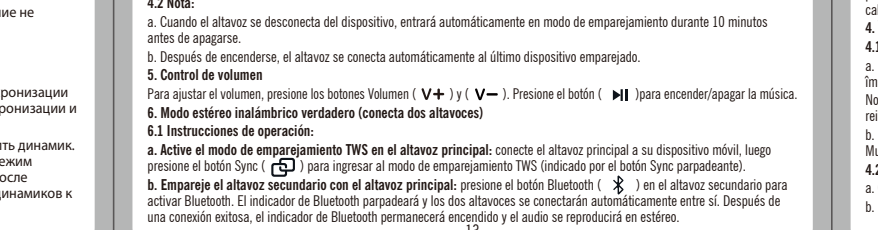

BATTERY LEVEL INDICATOR

The indicator displays the remaining battery level and turns off 5 minutes after charging begins.

CHARGING

Power Bank set up: Instructions on how to connect the power bank to the flashlight and ensure it is fully charged.

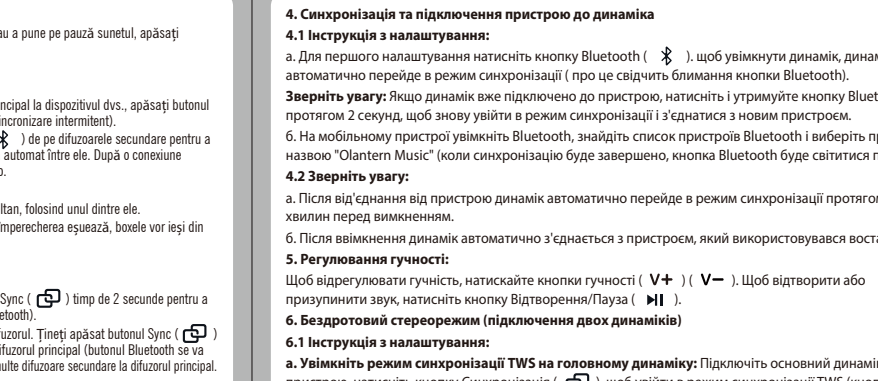
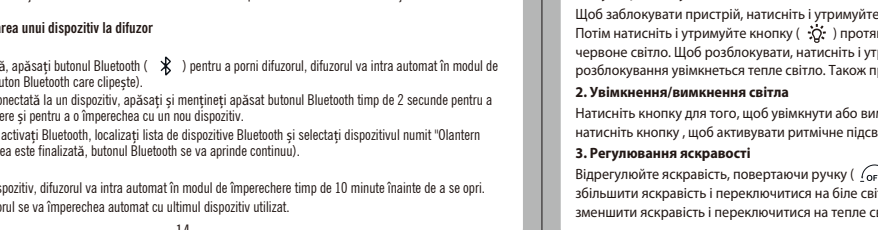

BATTERY LEVEL INDICATOR

The indicator displays the remaining battery level and turns off 5 minutes after charging begins.

CHARGING

Power Bank set up: Instructions on how to connect the power bank to the flashlight and ensure it is fully charged.

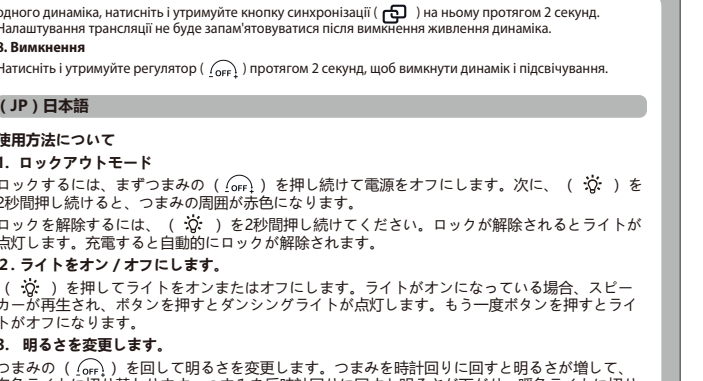
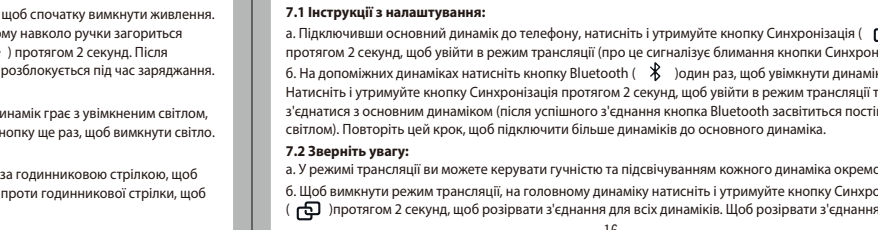

BATTERY LEVEL INDICATOR

The indicator displays the remaining battery level and turns off 5 minutes after charging begins.

CHARGING

Power Bank set up: Instructions on how to connect the power bank to the flashlight and ensure it is fully charged.

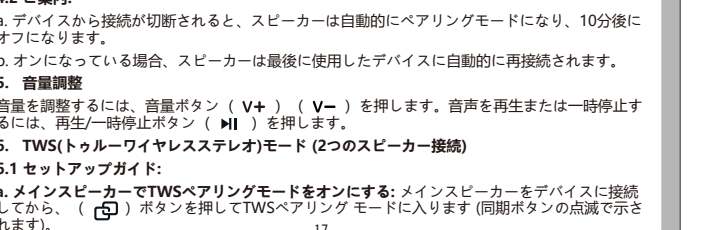

42. Obs: Instructions on how to use the flashlight in different modes and settings.

43. Instelaciones: Instructions on how to set up the flashlight and connect it to other devices.

44. 2.2. 2.2. Obs: Additional notes and instructions for the flashlight.

45. 2.2. 2.2. Obs: Additional notes and instructions for the flashlight.

46. 2.2. 2.2. Obs: Additional notes and instructions for the flashlight.

47. 2.2. 2.2. Obs: Additional notes and instructions for the flashlight.

48. 2.2. 2.2. Obs: Additional notes and instructions for the flashlight.

49. 2.2. 2.2. Obs: Additional notes and instructions for the flashlight.

50. 2.2. 2.2. Obs: Additional notes and instructions for the flashlight.