

N625P170654

Product manual
Gebrauchsanweisung
Manuel du produit
Manual del producto
Manuale del prodotto

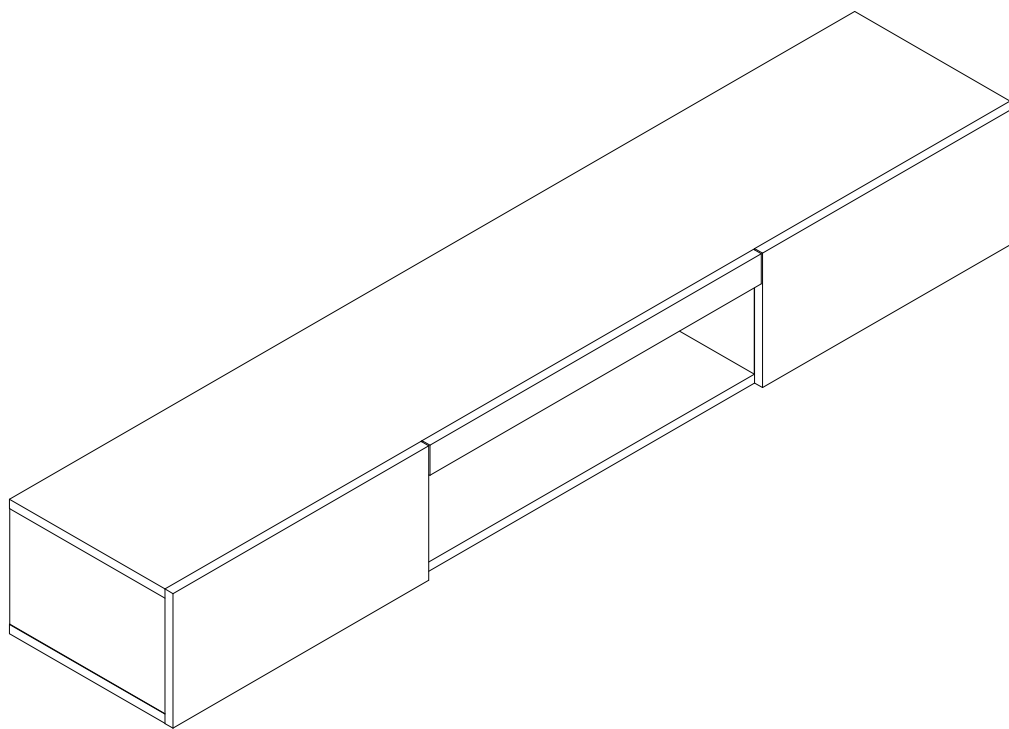

Importeur	Decobus Handel GmbH
Adresse	Innungsstraße 9, 21244 Buchholz, Deutschland
URL	https://www.decobusgroup.de
Hersteller	SHOUGUANG BOMAO TRADING CO.,LTD
Adresse	200 METERS SOUTH OF THE VILLAGE OFFICE OF DONGQI, SHENGCHENG STREET,SHOUGUANG CITY,SHANDONG,CHINA
Email/URL	https://bomaotrading.en.alibaba.com
	Decobus Handel GmbH Innungsstraße 9, 21244 Buchholz, Deutschland

 2PERS	 35 MIN	Tool Required Not Provided
-----------	------------	---



[DE]

Warnung: Erlauben Sie Kindern nicht, auf die Möbel zu klettern, da dies zum Umkippen und zu schweren Verletzungen führen kann.

Warnung: Um die Sicherheit zu gewährleisten, befolgen Sie bitte die Anweisungen zur korrekten Installation und holen Sie sich bei Bedarf professionelle Hilfe.

Warnung: Stellen Sie Möbel nicht in der Nähe von Feuerquellen oder Gegenständen mit hoher Temperatur auf, um Brandgefahr zu vermeiden.

[EN]

Warning: Do not allow children to climb on the furniture as this may result in tipping and serious personal injury.

Warning: To ensure safety, please follow the instructions for correct installation and seek professional assistance if necessary.

Warning: Do not place furniture close to fire sources or high-temperature objects to avoid the risk of fire.

[FR]

Avertissement : Ne laissez pas les enfants grimper sur les meubles car cela pourrait entraîner un basculement et des blessures graves.

Avertissement : pour garantir la sécurité, veuillez suivre les instructions pour une installation correcte et demander l'aide d'un professionnel si nécessaire.

Avertissement : Ne placez pas les meubles à proximité de sources d'incendie ou d'objets à haute température pour éviter tout risque d'incendie.

[IT]

Attenzione: non permettere ai bambini di arrampicarsi sui mobili poiché ciò potrebbe causare ribaltamento e gravi lesioni personali.

Attenzione: per garantire la sicurezza, seguire le istruzioni per una corretta installazione e, se necessario, richiedere assistenza professionale.

Attenzione: non posizionare i mobili vicino a fonti di fuoco o oggetti ad alta temperatura per evitare il rischio di incendio.

[ES]

Advertencia: No permita que los niños se suban a los muebles, ya que esto podría provocar vuelcos y lesiones personales graves.

Advertencia: Para garantizar la seguridad, siga las instrucciones para una instalación correcta y busque asistencia profesional si es necesario.

Advertencia: No coloque muebles cerca de fuentes de fuego u objetos de alta temperatura para evitar el riesgo de incendio.

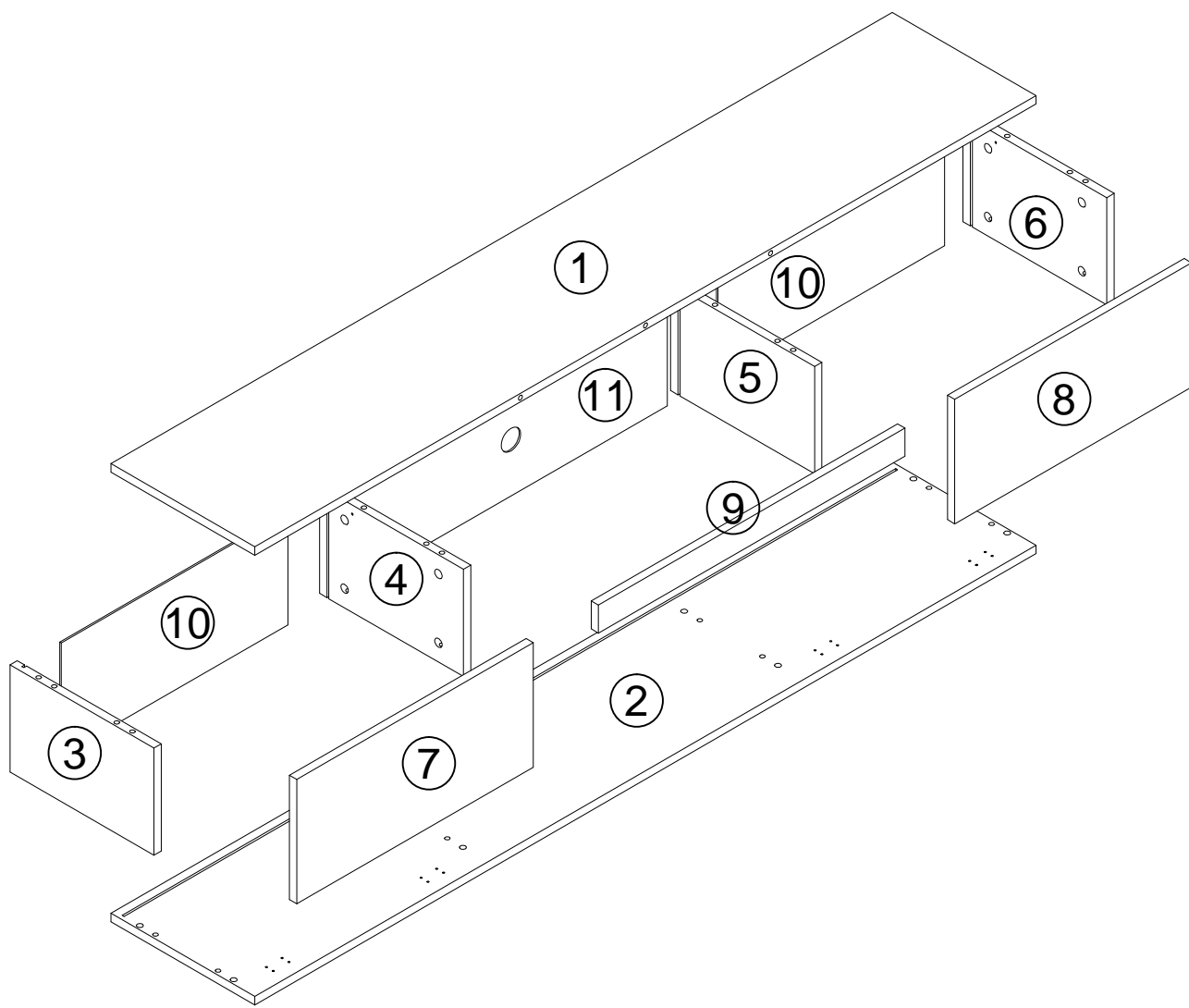



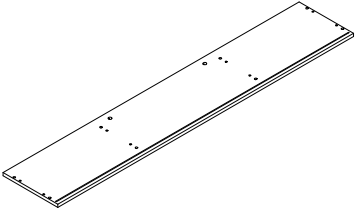
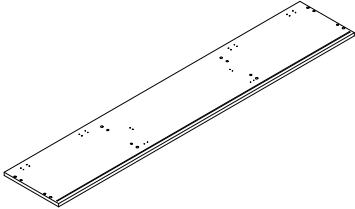
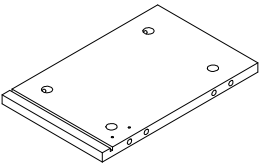
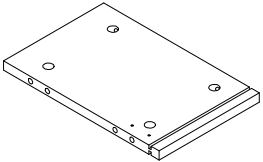
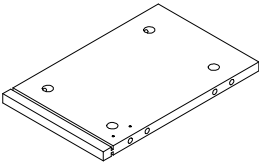
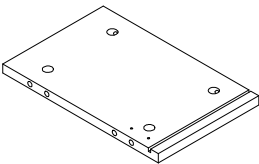
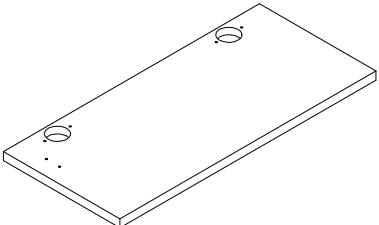
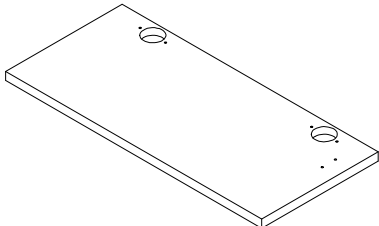

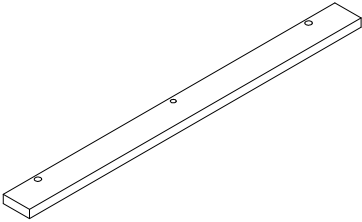
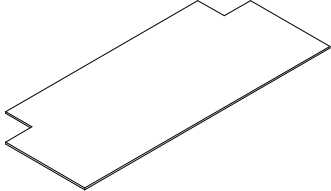
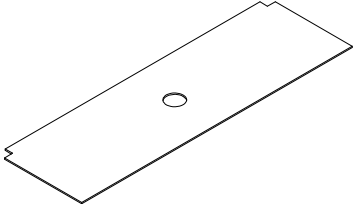
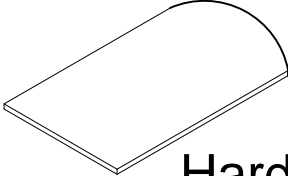



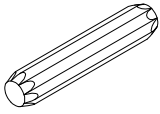

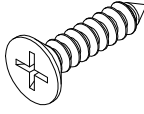
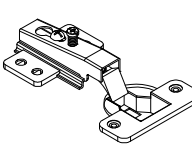
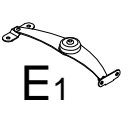
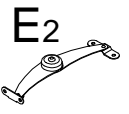

N625P170654

①		1
②		1
③		1
④		1
⑤		1
⑥		1
⑦		1
⑧		1

⑨		1
⑩		2
⑪		1
 <p>Hardware kit</p>		

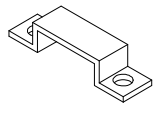
Hardware List for N625P170654

<p>A</p> <p>M8*40</p>  <p>16PCS</p>	<p>B</p> <p>B1</p>  <p>M6*40</p> <p>B2</p>  <p>19PCS</p>	<p>C</p> <p>M3.5*14</p>  <p>50PCS</p>	<p>D</p>  <p>4PCS</p>
<p>E</p> <p>E1</p>  <p>E2</p>  <p>1PCS</p>	<p>F</p> <p>F1</p>  <p>F2</p>  <p>F3</p>  <p>F4</p>  <p>F5</p>  <p>4PCS</p>	<p>G</p>  <p>12PCS</p>	<p>H</p>  <p>19PCS</p>
<p>J</p>  <p>3 PCS</p>	<p>K</p>  <p>1PCS</p>		

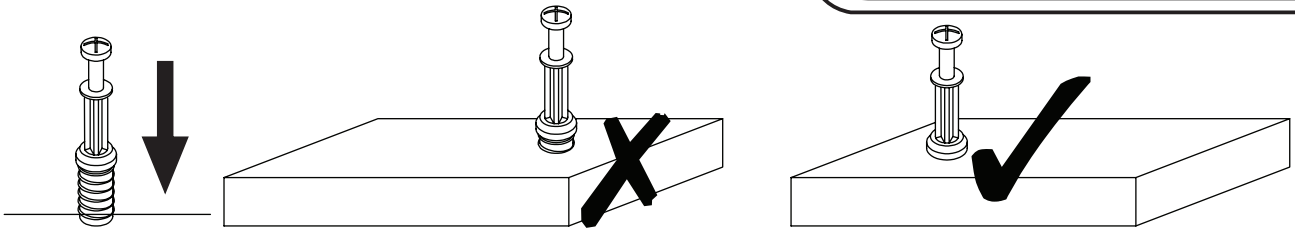

EN_QUICKFIT: Tighten quickfit until shoulder is flush with panel. Do not overtighten or undertighten.

FR_RACCORD RAPIDE: Faites serrer le raccord rapide jusqu'à ce que l'épaulement soit parfaitement encastré dans le panneau. Il ne faut ni trop serrer ni insuffisamment serrer.

ES_QUICKFIT: Apriete quickfit hasta que el hombro se descargue con el panel. NO lo sobreapriete ni lo apriete poco.

DE_QUICKFIT: Ziehen Sie den Quickfit fest, bis die Schulter mit der Platte bündig ist. Bitte nicht zu fest oder zu schwach anziehen.

IT_MONTAGGIO RAPIDO: Stringere il montaggio rapido fino a quando la spalla è a filo con il pannello, non stringere troppo o troppo poco.

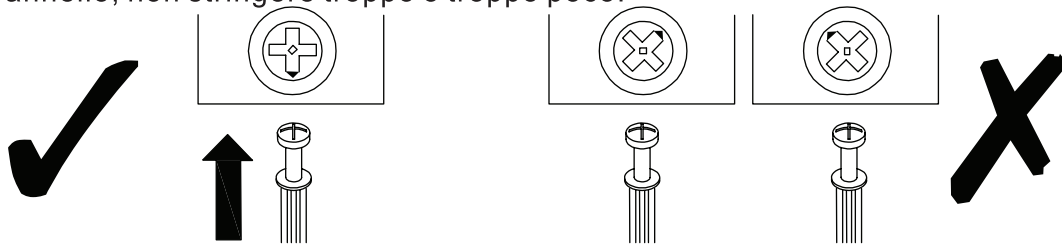

EN_CAM LOCK: When fitting cam lock, ensure starting position is correct before you insert connecting quickfit.

FR_SERRURE BATTEUSE: Avant d'insérer la serrure batteuse, veillez à la bonne orientation avant d'insérer le raccord rapide.

ES_CIERRE DE LA CÁMARA: Cuando instale el cierre de la cámara, asegúrese de que la posición de inicio es correcta antes de que inserte el quickfit conector.

DE_CAM-LOCK: Achten Sie bei der Montage des Cam-Locks auf die richtige Ausgangsposition, bevor Sie den Quickfit einsetzen.

IT_BLOCCAGGIO A CAMMA: Quando si monta il bloccaggio a camma, assicurarsi che la posizione iniziale sia corretta prima di inserire il montaggio rapido di collegamento.

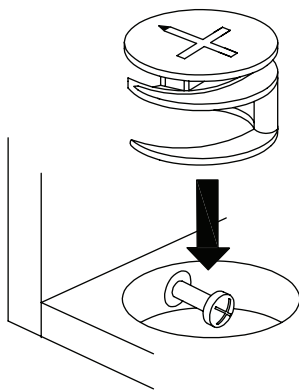

EN_Quickfit head should be in the centre of the cam lock when the two panels are joined.

Cam lock should be inserted before quickfit.

FR_Lorsque les deux panneaux sont assemblés, la tête du raccord rapide doit reposer au centre de la serrure batteuse. Il faut insérer la serrure batteuse avant le raccord rapide.

ES_El cabezal del quickfit debe estar en el centro del cierre de la cámara cuando se unan los dos paneles.

Se debe insertar el cierre de la cámara antes que el quickfit.

DE_Der Quickfit-Kopf sollte sich in der Mitte des Cam-Locks befinden, wenn die beiden Platten zusammengefügt sind. Der Cam-Lock sollte vor dem Quickfit eingesetzt werden.

IT_La testa del montaggio rapido deve trovarsi al centro del bloccaggio a camma quando i due pannelli sono uniti.

Il Bloccaggio a Camma deve essere inserito prima del montaggio rapido.

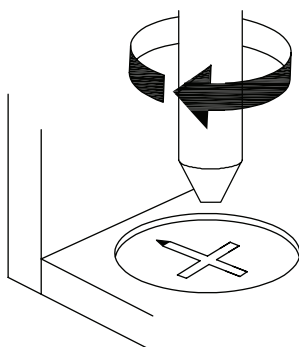

EN_Turn cam lock clockwise to tighten.

FR_Faites tourner la serrure batteuse dans le sens des aiguilles d'une montre pour la resserrer.

ES_Gire el cierre de la cámara en sentido horario para apretarlo.

DE_Drehen Sie den Cam-Lock im Uhrzeigersinn, um ihn festzuziehen.

IT_Ruotare il bloccaggio a camma in senso orario per stringere.

EN It may be necessary to adjust the hinges so that the doors align. Use the instructions below as a guide.

FR Il est parfois nécessaire d'ajuster les charnières pour un meilleur alignement des portes. Servez-vous des instructions ci-dessous comme guide.

ES Puede que sea necesario ajustar los quicios de forma que se alineen las puertas. Use las instrucciones que aparecen debajo como guía.

DE Möglicherweise müssen Sie die Scharniere so einstellen, dass die Türen ausgerichtet sind. Verwenden Sie die nachstehenden Anweisungen als Leitfaden.

IT Potrebbe essere necessario regolare le cerniere in modo che le porte siano allineate. Per fare ciò attenersi alle istruzioni sottostanti.

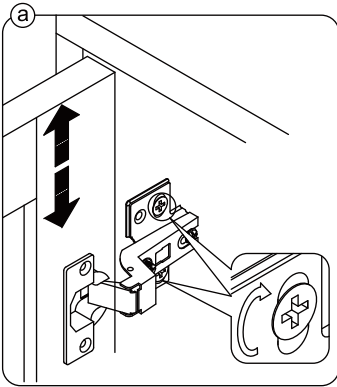

EN To adjust the door vertically loosen the screw as shown and move up and down as needed.

FR Si vous souhaitez régler la porte **verticalement**, desserrez la vis comme indiqué et déplacez la porte de haut en bas selon les besoins.

ES Para ajustar la puerta **verticalmente** afloje el tornillo tal y como se muestra y muévelo hacia arriba o hacia abajo según sea necesario.

DE Um die Tür **vertikal** auszurichten, lösen Sie die Schraube wie abgebildet und bewegen Sie sie nach Bedarf nach oben oder nach unten.

IT Per allineare la porta **verticalmente** allentare la vite come mostrato e spostarla in alto o in basso secondo necessità.

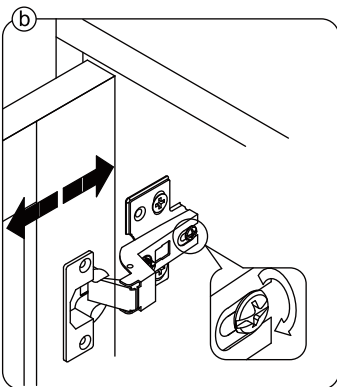

EN To adjust the gap from the door to the main frame turn the screw clockwise or anti-clockwise as needed.

FR Si vous souhaitez ajuster l'**écart** entre la porte et le cadre principal, tournez la vis dans le sens des aiguilles d'une montre ou dans le sens inverse, si nécessaire.

ES Para ajustar el **espacio** desde la puerta al marco principal, gire el tornillo en sentido horario o antihorario, según se necesite.

DE Um den **Abstand** von der Tür zum Hauptrahmen auszurichten, drehen Sie die Schraube je nach Bedarf im oder gegen den Uhrzeigersinn.

IT Per regolare lo **spazio** tra la porta e il telaio principale, avvitare o svitare la vite secondo necessità.

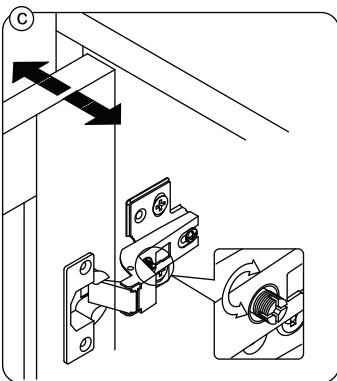

EN To adjust the door laterally adjust the screw as shown by turning clockwise or anti-clockwise.

FR Si vous souhaitez ajuster la porte **latéralement**, ajustez la vis comme indiqué en tournant dans le sens des aiguilles d'une montre ou dans le sens inverse des aiguilles d'une montre.

ES Para ajustar la puerta **lateralmente** ajuste el tornillo tal y como se muestra girándolo en sentido horario y antihorario.

DE Um die Tür **seitlich** auszurichten, stellen Sie bitte die Schraube wie abgebildet durch Drehen im oder gegen den Uhrzeigersinn ein.

IT Per allineare la porta **lateralmente** regolare la vite come mostrato, avvitarandola o svitarandola.

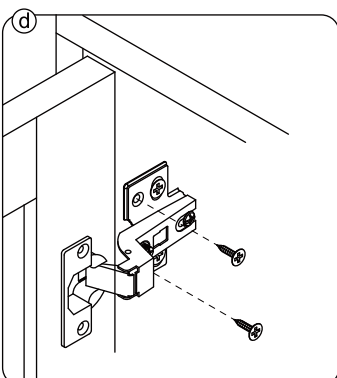

EN Please fix other screws

FR Merci de serrer les autres vis.



ES Fije los demás tornillos

DE Befestigen Sie bitte die anderen Schrauben

IT Fissare le altre viti

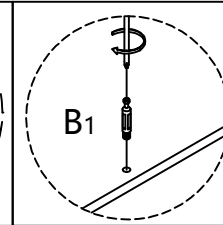
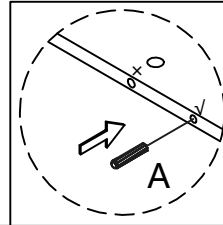
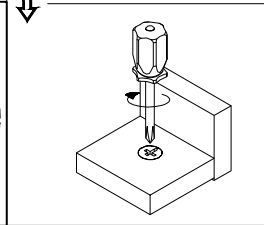
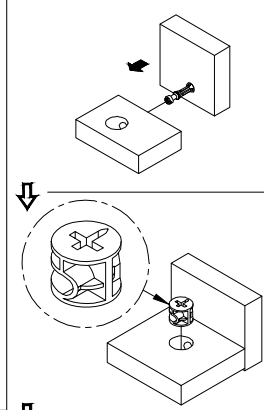
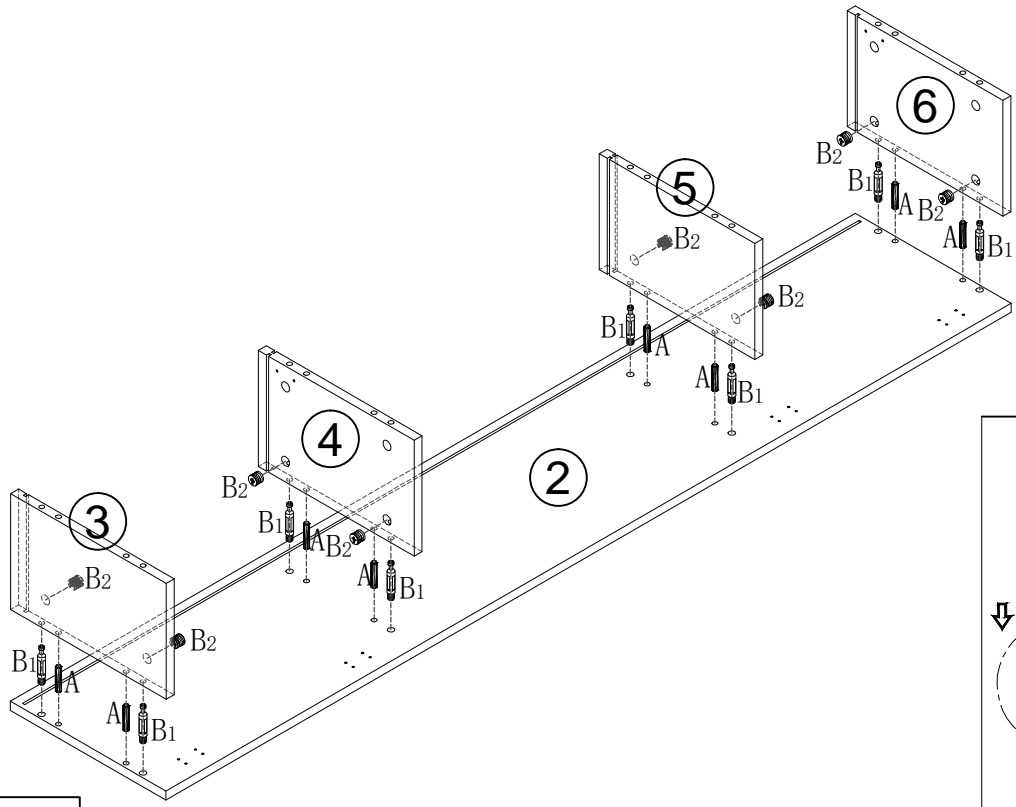
STEP 1



	Ax8pcs
	B1x8pcs
	B2x8pcs

STEP 2

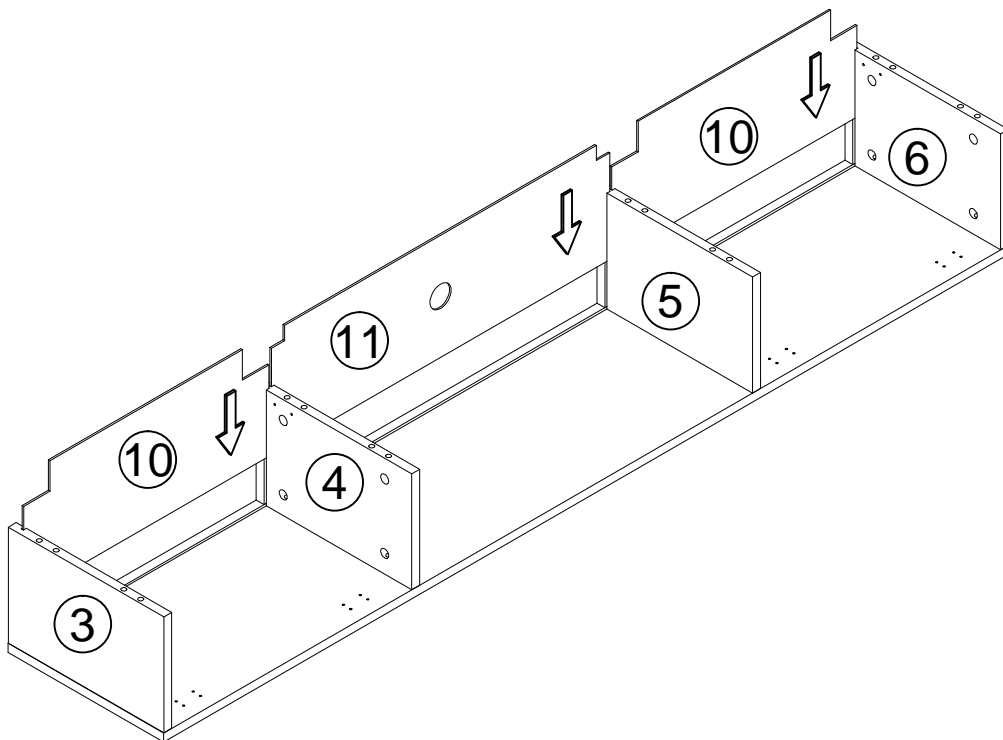

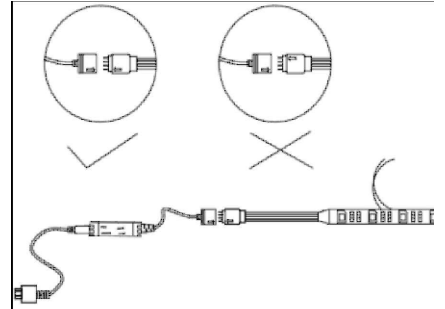
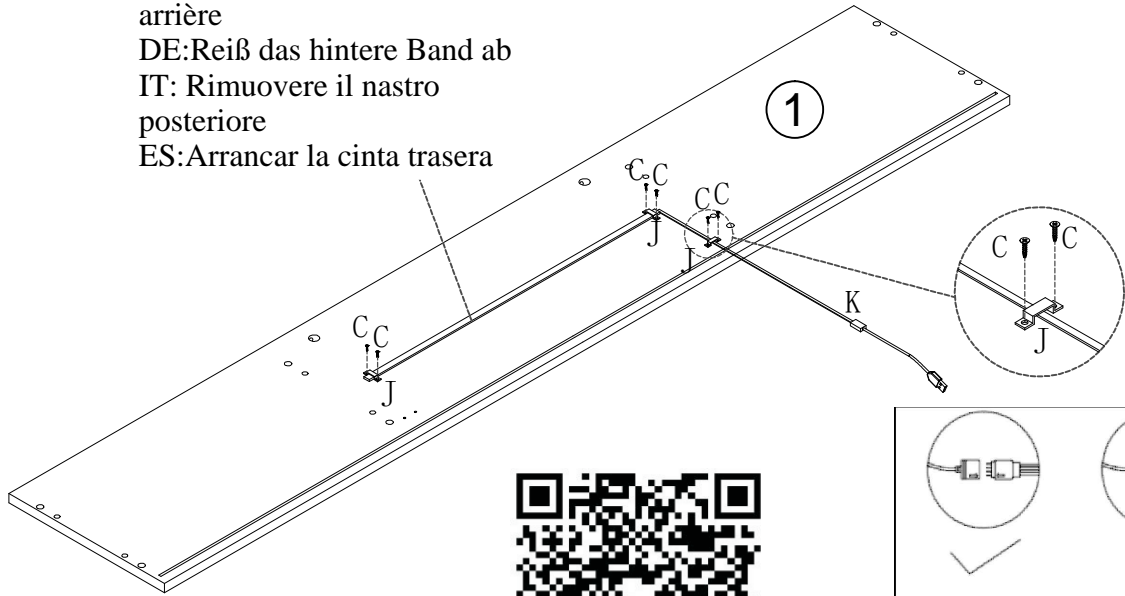

STEP 3

EN:Tear off the back tape
 FR:Déchirer le ruban adhésif
 arrière
 DE:Reiß das hintere Band ab
 IT: Rimuovere il nastro
 posteriore
 ES:Arrancar la cinta trasera



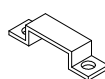

UK : The connection of light stripe
 DE : Die Verbindung von Lichtstreifen
 FR : La connexion de la bande lumineuse
 IT:La connessione della striscia di luce
 ES:La conexión de la franja de luz

	Kx1pcs
	Jx3pcs
	Cx6pcs

EN:Scan to download App control the Led light.
 DE:Das led-display wird durchsucht.
 FR:Scanner pour télécharger App contrôler la lumière Led.
 IT:Scansiona per scaricare l' applicazione
 controlla la luce Led.
 ES:Analice para descargar la aplicación
 control de la luz Led.

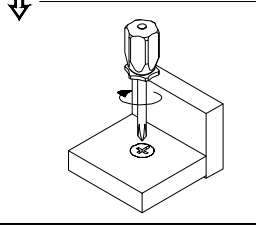
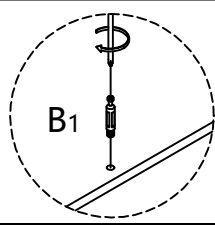
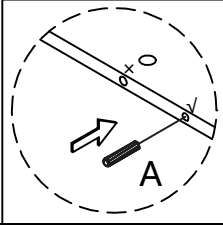
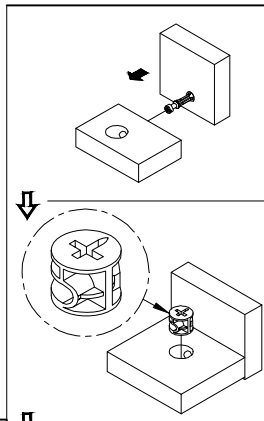
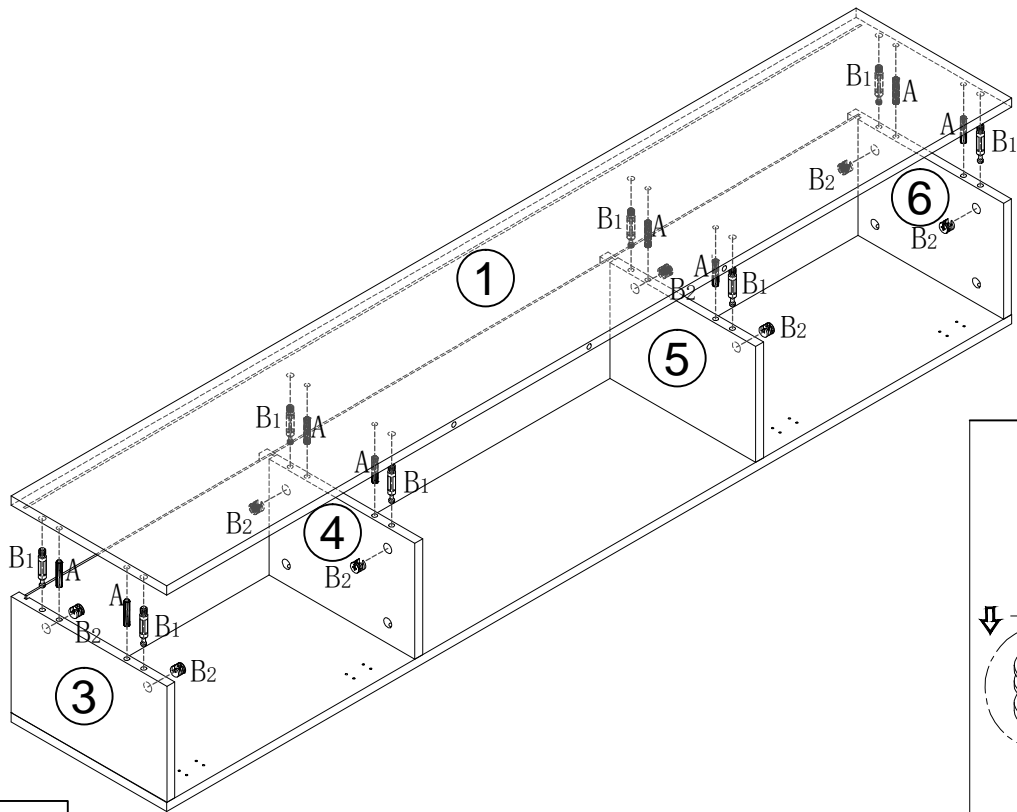

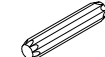
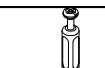
STEP 4



	Ax8pcs
	B ₁ x8pcs
	B ₂ x8pcs

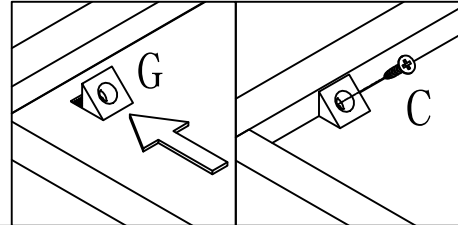
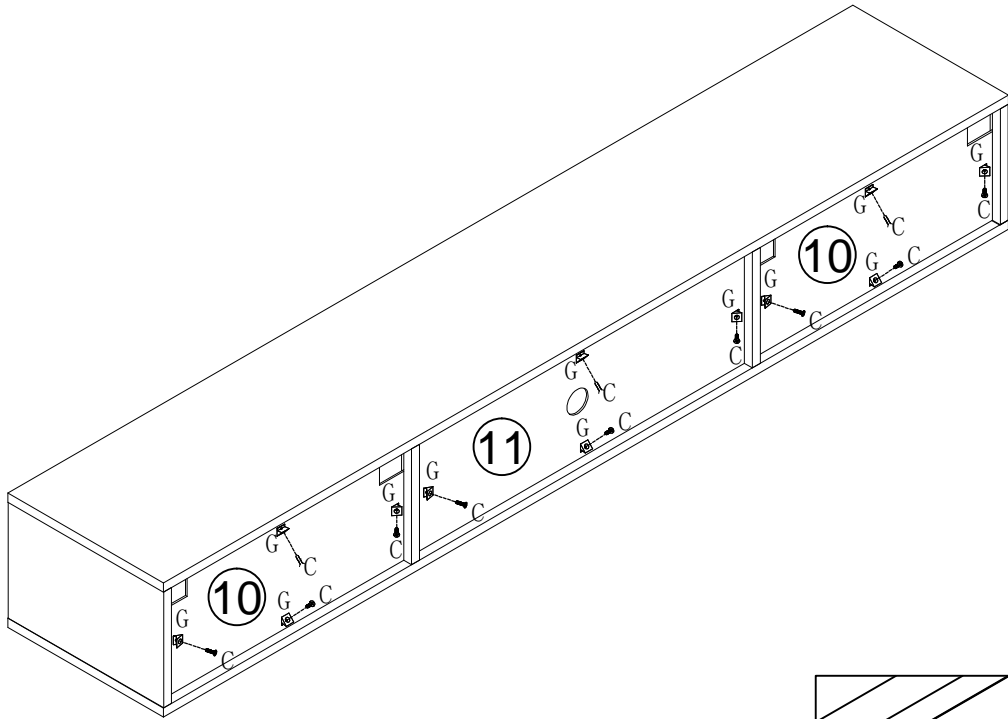

STEP 5

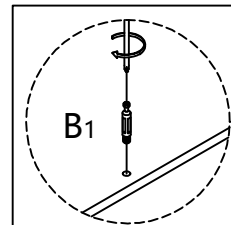
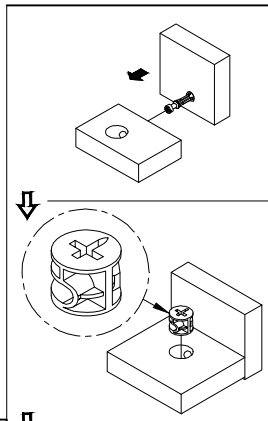
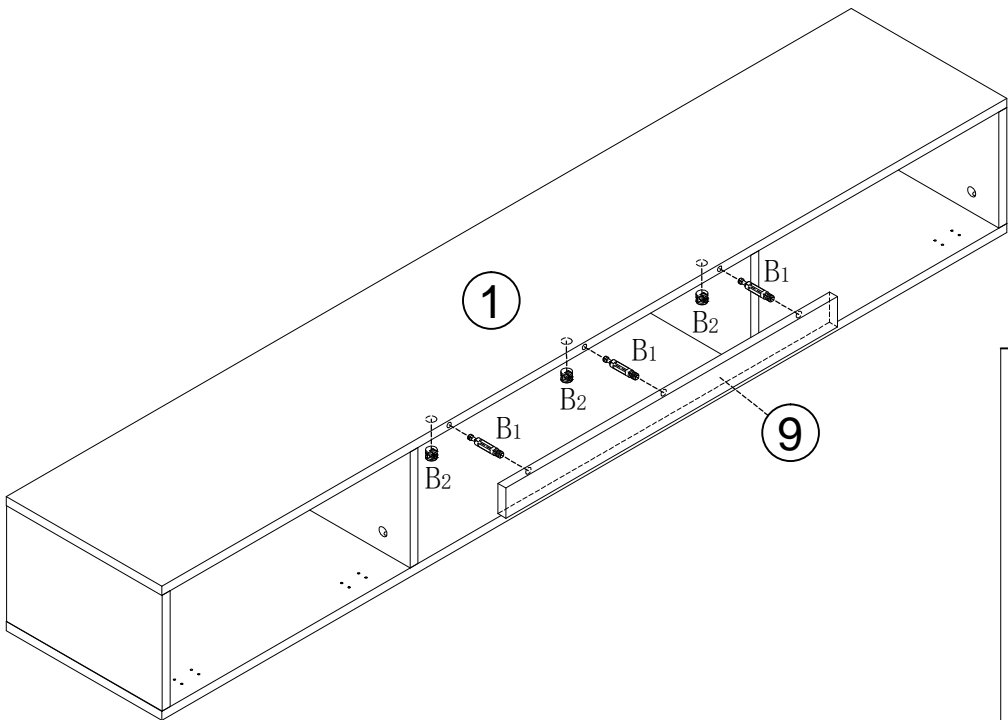

	Cx12pcs
	Gx12pcs

STEP 6



	B ₁ x3pcs
	B ₂ x3pcs

STEP 7

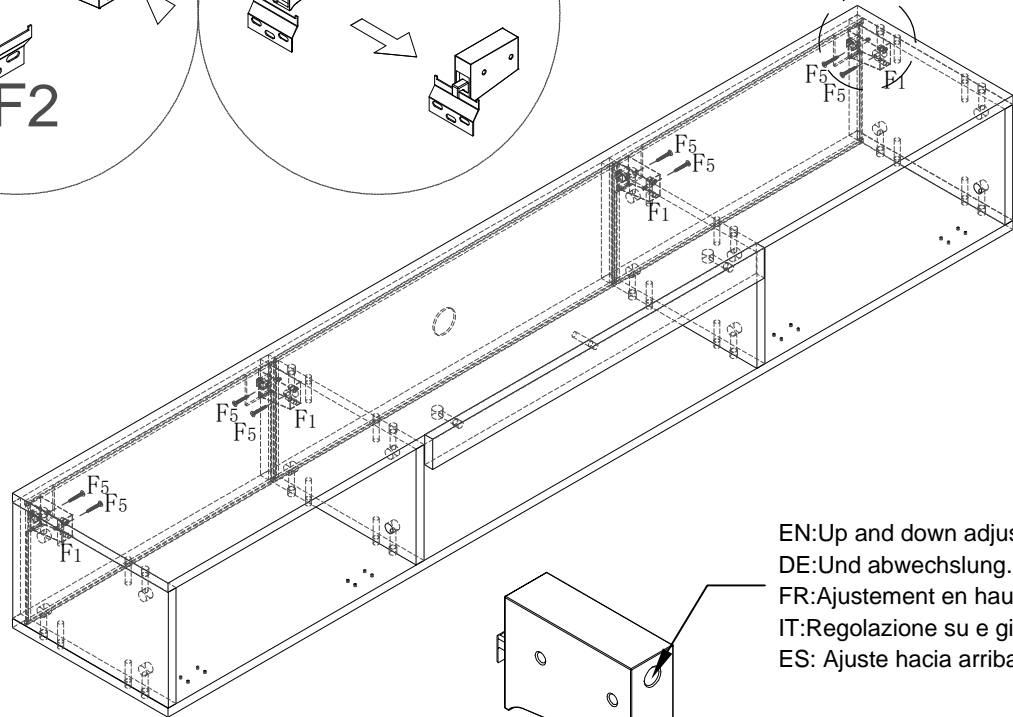
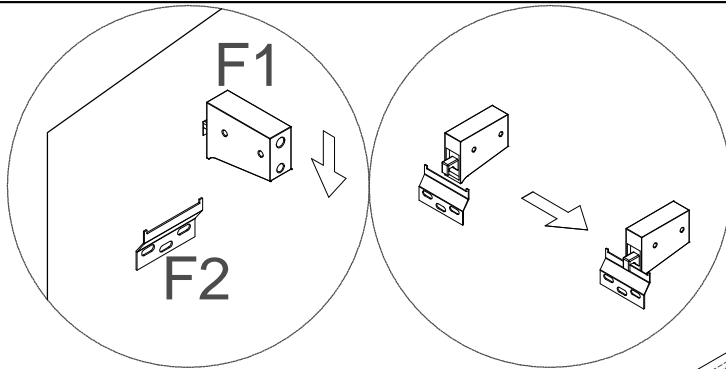
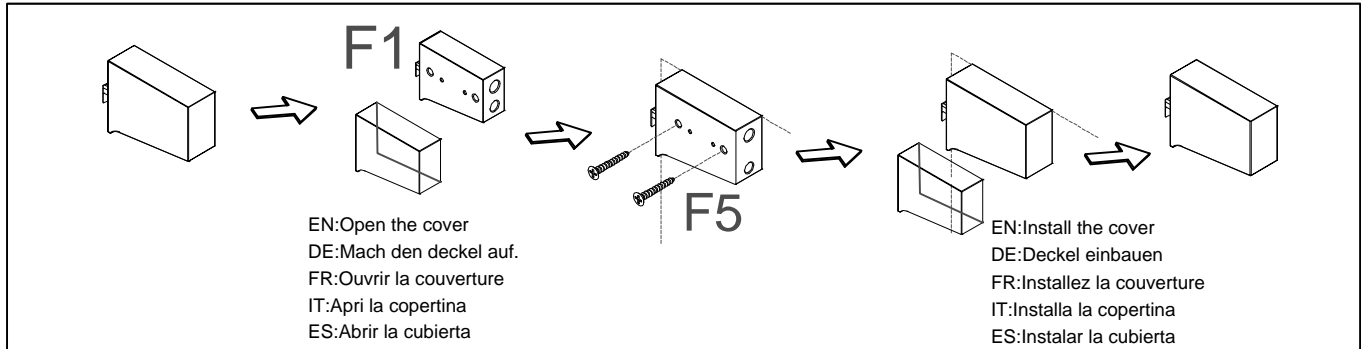
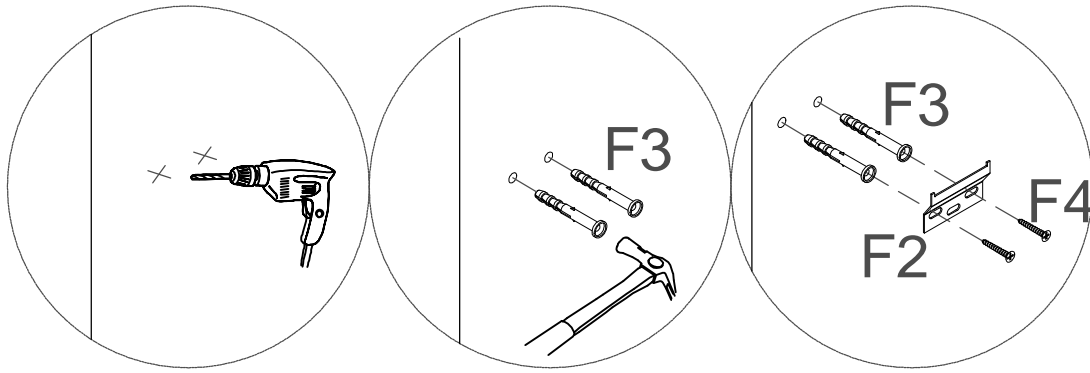

	F ₁ x8pcs
	F ₂ x8pcs
	F ₃ x8pcs

	F ₄ x8pcs
	F ₅ x8pcs

STEP 8

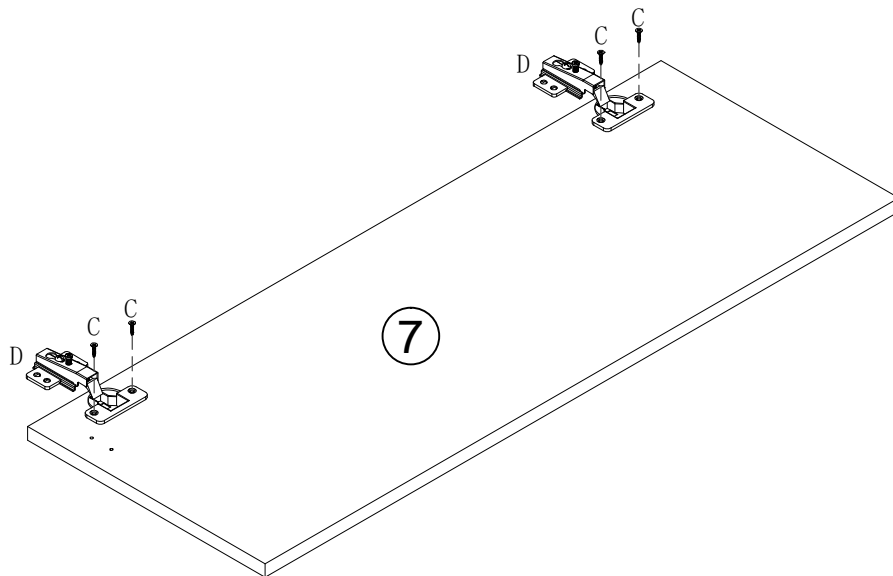
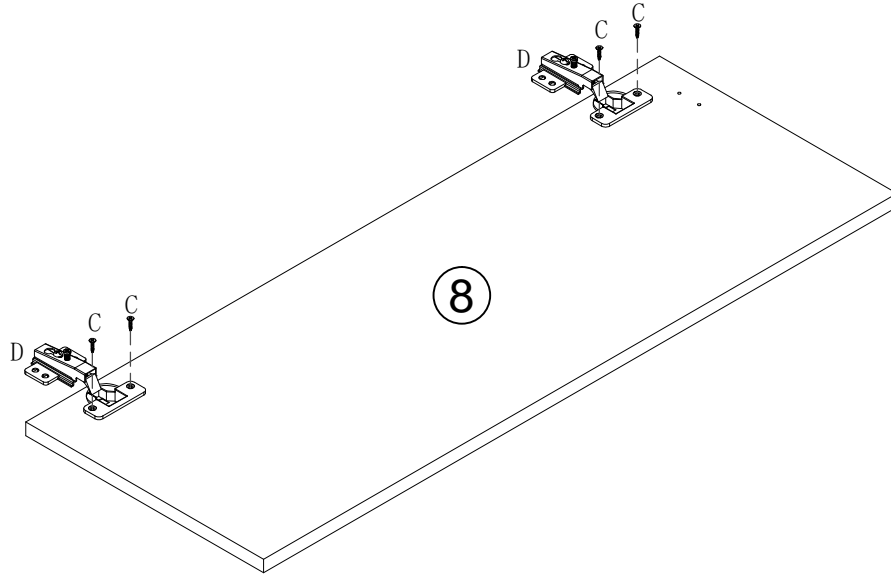



Cx8pcs

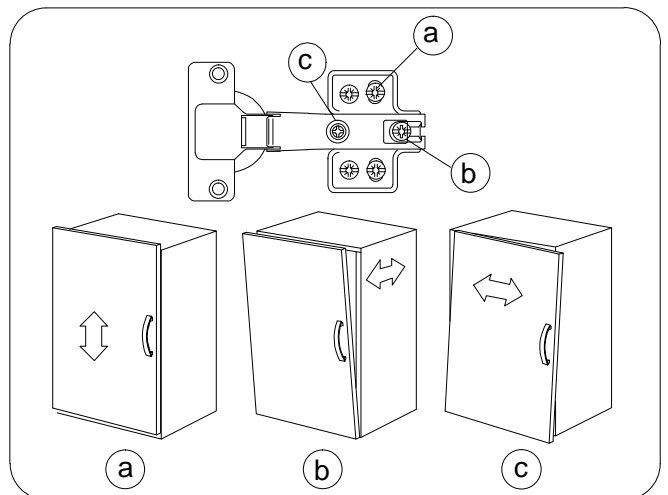
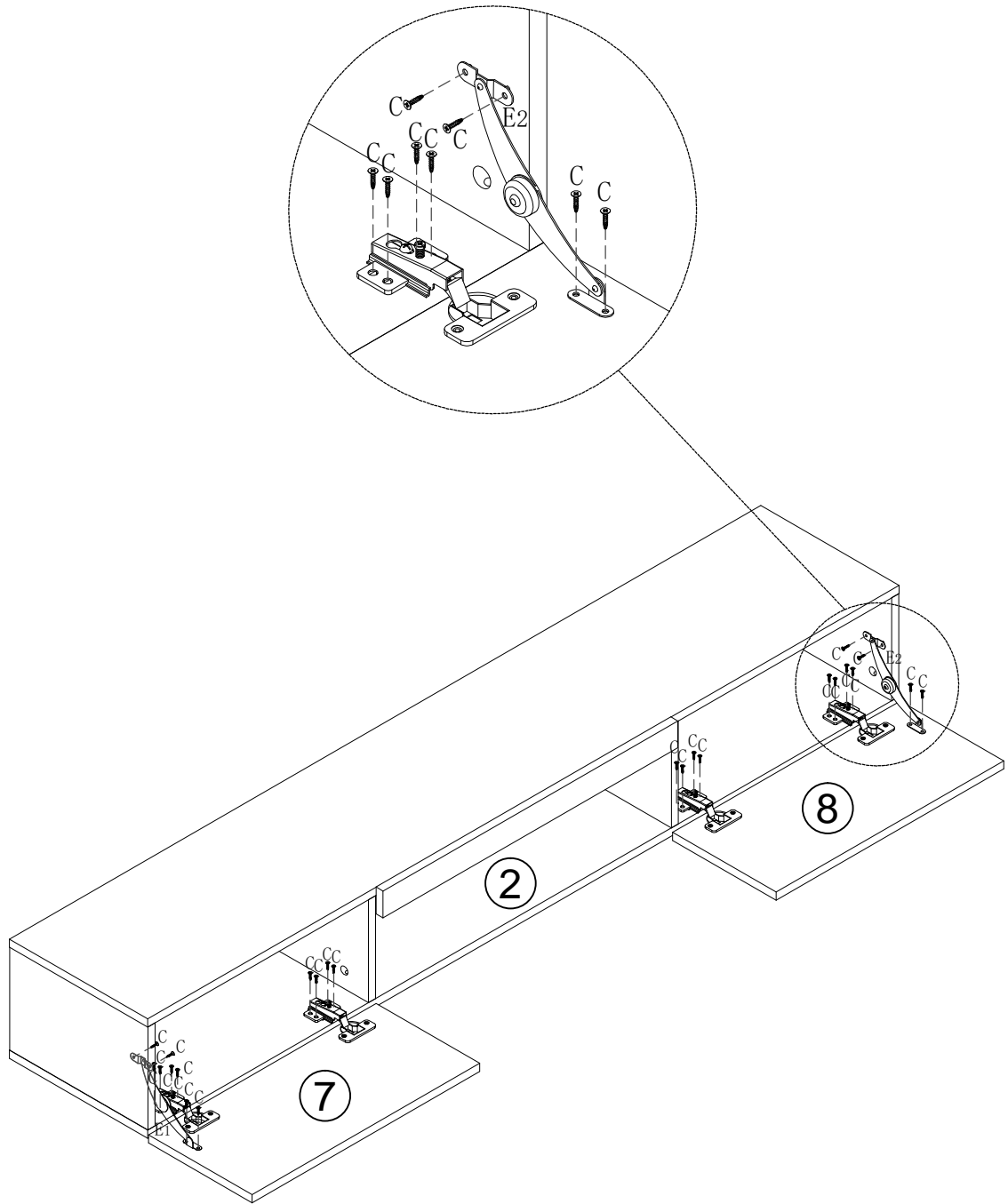

Dx4pcs

STEP 9

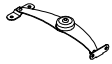
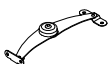

	Cx24pcs
	E1x1pcs
	E2x1pcs

STEP 10

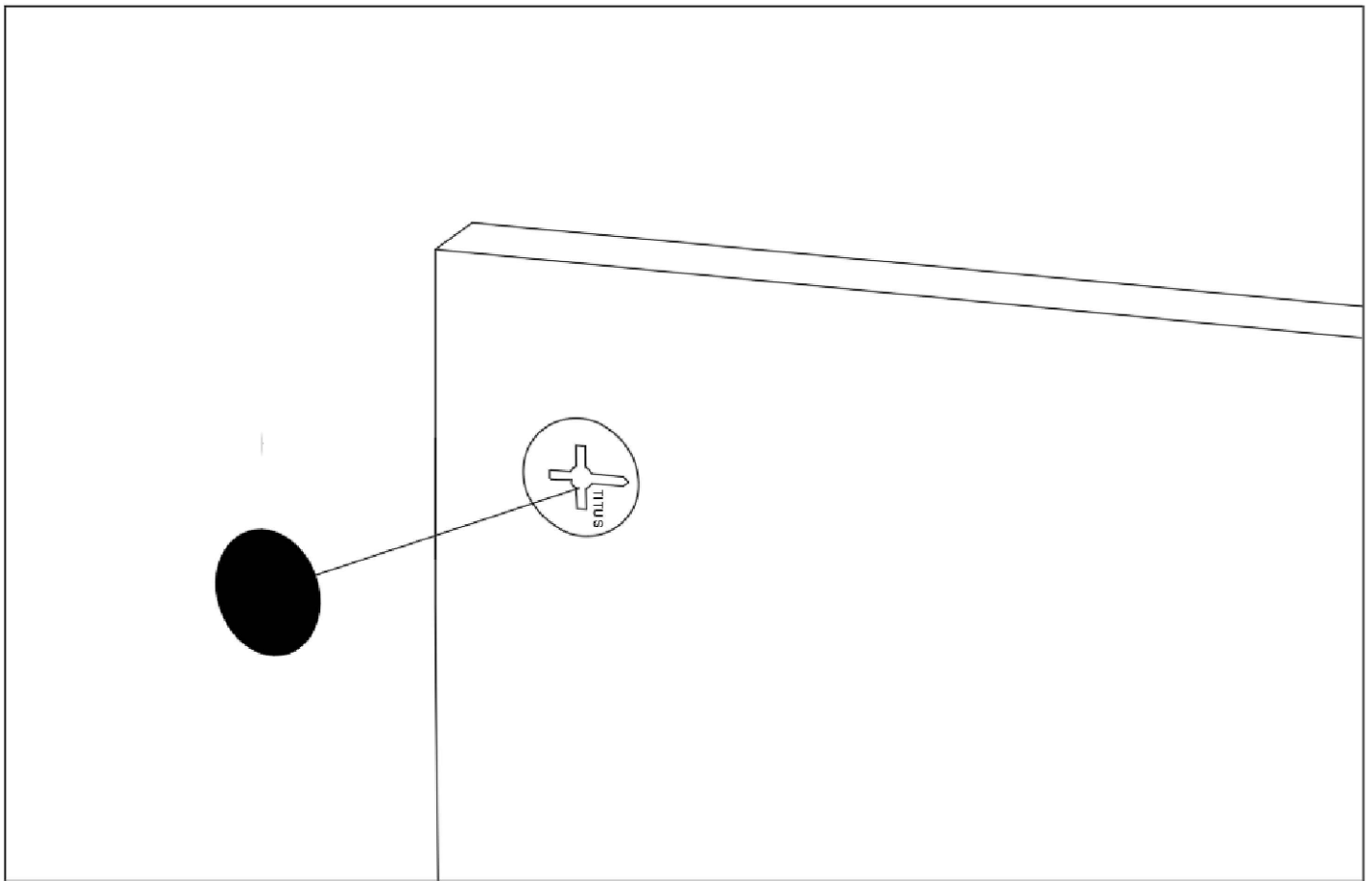

EN: After installing the product, stick the number Q on the perforated position

FR: Une fois le produit installé, collez le numéro Q à l'endroit où il y a des trous

DE: Nach der Installation des Produkts kleben Sie die Nummer Q auf die perforierte Position

IT: Dopo l'installazione del prodotto, fissare il numero Q sulla posizione perforata

ES: Después de instalar el producto, pegue el número Q en la posición perforada



Hx18pcs

Verification of Compliance

Verification No.: TMC210319126-E

Name and address of Applicant: **Shenzhen CWG Technology Co., Ltd**
5 / F, No.264 Baoshi East Road, Shiyan street, Bao'an District, Shenzhen,China 518108

Name and address of Manufacturer: **Shenzhen CWG Technology Co., Ltd**
5 / F, No.264 Baoshi East Road, Shiyan street, Bao'an District, Shenzhen,China 518108

Product name: **LED Strip**

Rated: DC12V

Product model(s): CWG-5050RGB-60D-12V , additional models reference attachment

Product trademark: 创唯光

This verification confirms that the product meets the requirements of the following standard. The conformity was demonstrated based on following standard(s) listed by European Commission as harmonized with EMC Directive 2014/30/EU.

EN IEC 55015:2019+A11:2020
IEC 61547:2020

The verification has been carried out in accordance with individual rules and conditions agreed with the applicant. Evaluation has been carried out in accordance with:

Test report(s) No.: TMC210319126-E

Test conducted by: TMC Testing Services (Shenzhen) Co., Ltd.

Verification issue date: March 26, 2021

Notes:

This verification refers to the above mentioned product and its conformity in regards of above mentioned standard(s) was proven on test sample.

This verification does not imply meeting all essential requirements, assessment of the series-production or any other restricted Notified Bodies conformity assessment procedure appropriate for the product.

This verification holder shall use this verification in connection to verification of conformity and technical data relevant for the product the verification was issued.

TMC Testing Services (Shenzhen) Co., Ltd.

t:86-755-86642861 cert@tmc-lab.com www.tmc-lab.com

1st Floor, Block A1, Zone A, Xinshidai Gongrong Industrial Park, No. 2, Shihuan Road, Shiyan Street, Baoan District, Shenzhen, China



Lab Director
Lemon Rao

