

Art. 369110 256690

LKZ 41332

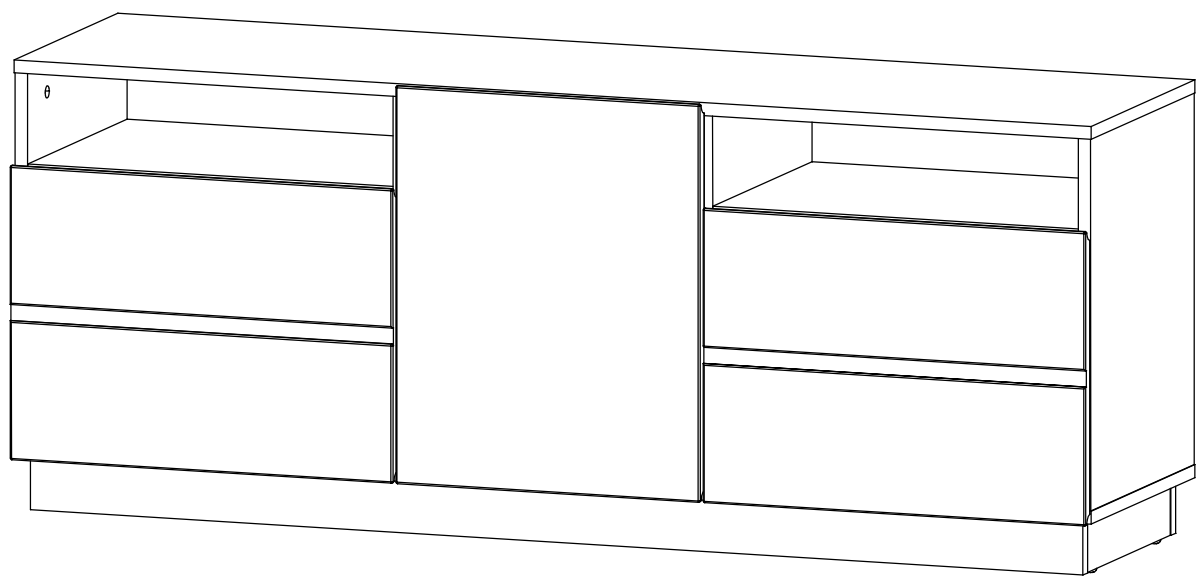

Service • Assistenza • Dienstverlening • Serwis
 Servis • Szerviz • Сервисная служба

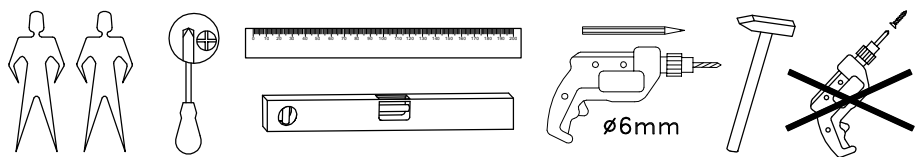





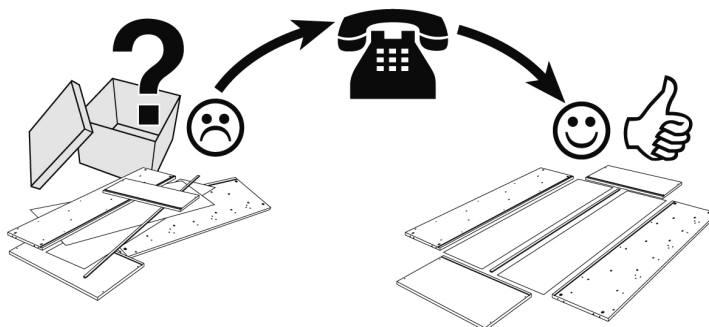
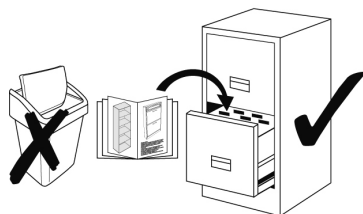



Name • Nom • Nome • Naam
 Nazwa • Jméno • Názov • Név
 Denumire • Isim • Название

Nr • No • N • Номер • Č • Sz

Typ • Type • Típus • Tipo
 Тип

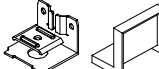

0
10
20
30
40
50
60
70
80
90
100
110
120
130
140
150
160
170
180

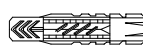
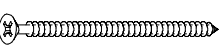
		H1		x36 ø 8x30	D2		x36 ø 5/11x34	
D1		x4	D5		x36 ø 15x12,5	D4		x24 ø 17
G39		x4 ø 35	G40		x2 ø 35	A65		x12 ø 4x17
G33		x6	D31		x1	A10		x2 ø 4x16
D36		x12	H8		x1 ø 6x35	A69		x1 ø 4x60

Teil Nr. Pièces Nr. Pieces Nr. Часть Ном. Kawalek Nr. Parça No Kusù Nr. Kusov Nr. Pezzi Nr. Nr piese. Darab száma. Stukken Nr. Kārtas Nr.	Anzahl Quantité Quantity Количество Ilość Miktar Množství Množstvo Quantità Cantitatea Mennyiség Hoeveelheid Skaitis	Kasten Nr. Colli Nr. Colli Nr. Коробка Ном. Polu Nr. Kutusu Nr. Kolonka Č. Počet balení Colli Nr. Nu pachete Colli száma. Colli Nr. Kastes Nr.	Maß, mm Dimensions, mm Dimensions, mm Размеры, mm Wymiary, mm Boyutlar, mm Rozměry, mm Rozmery, mm Dimensioni, mm Dimensiuni, mm Méterek, mm Afmetingen, mm Izmēri, mm	✓
13	1	2/2	460 x 362 x 16	
14	1	2/2	460 x 362 x 16	
15	1	2/2	460 x 362 x 16	
16	1	2/2	460 x 362 x 16	
24	1	2/2	1402 x 363 x 16	
25	1	2/2	1402 x 363 x 16	
33	2	2/2	476 x 347 x 16	
39	1	2/2	383 x 347 x 16	
50	3	2/2	292 x 66 x 16	
53	2	2/2	1370 x 66 x 16	
67	2	1/2	469 x 485 x 3	
68	1	1/2	469 x 393 x 3	
112	2	1/2	498 x 364 x 43	
113	1	1/2	492 x 396 x 43	

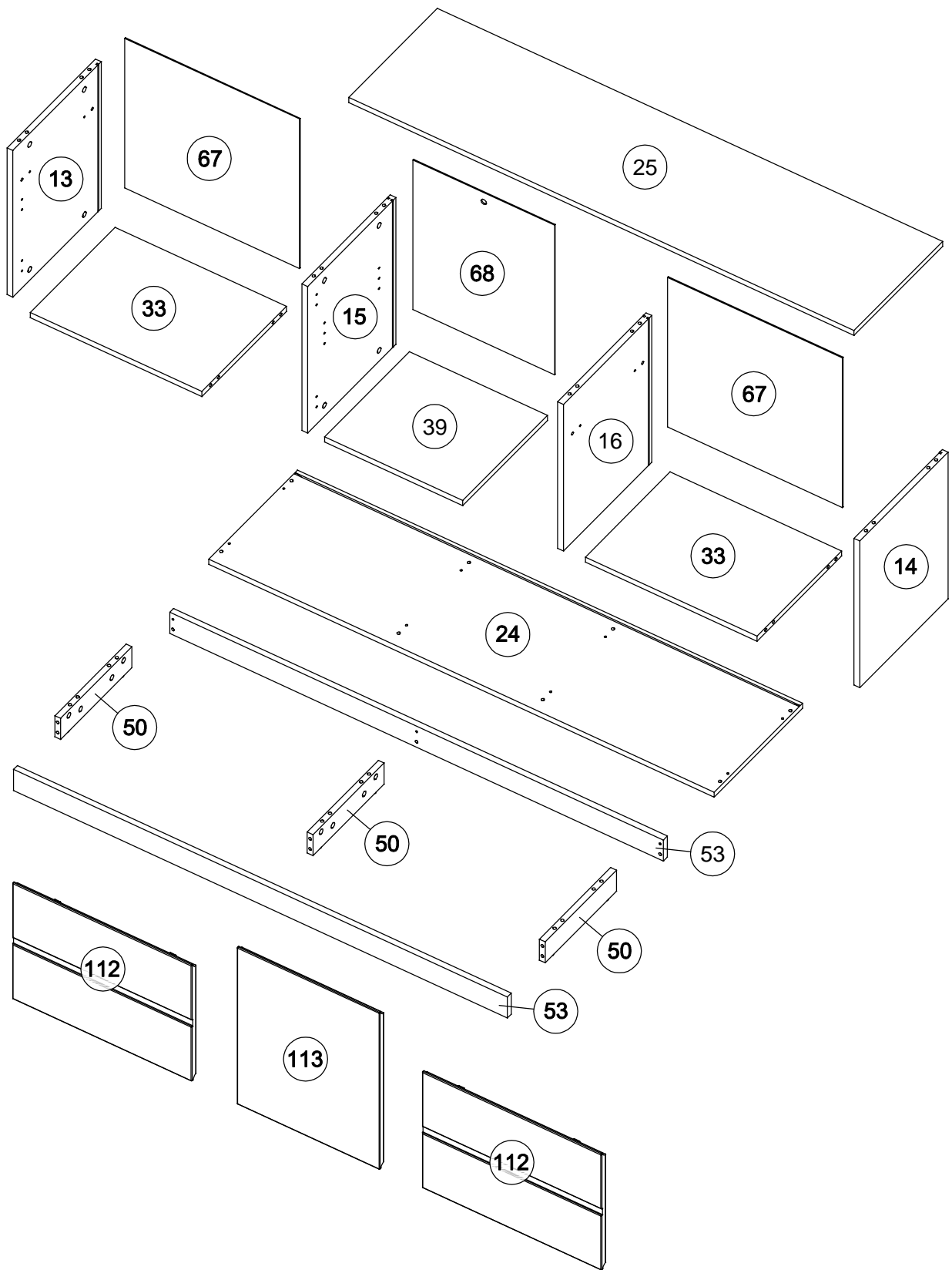

67286-1 67286-2



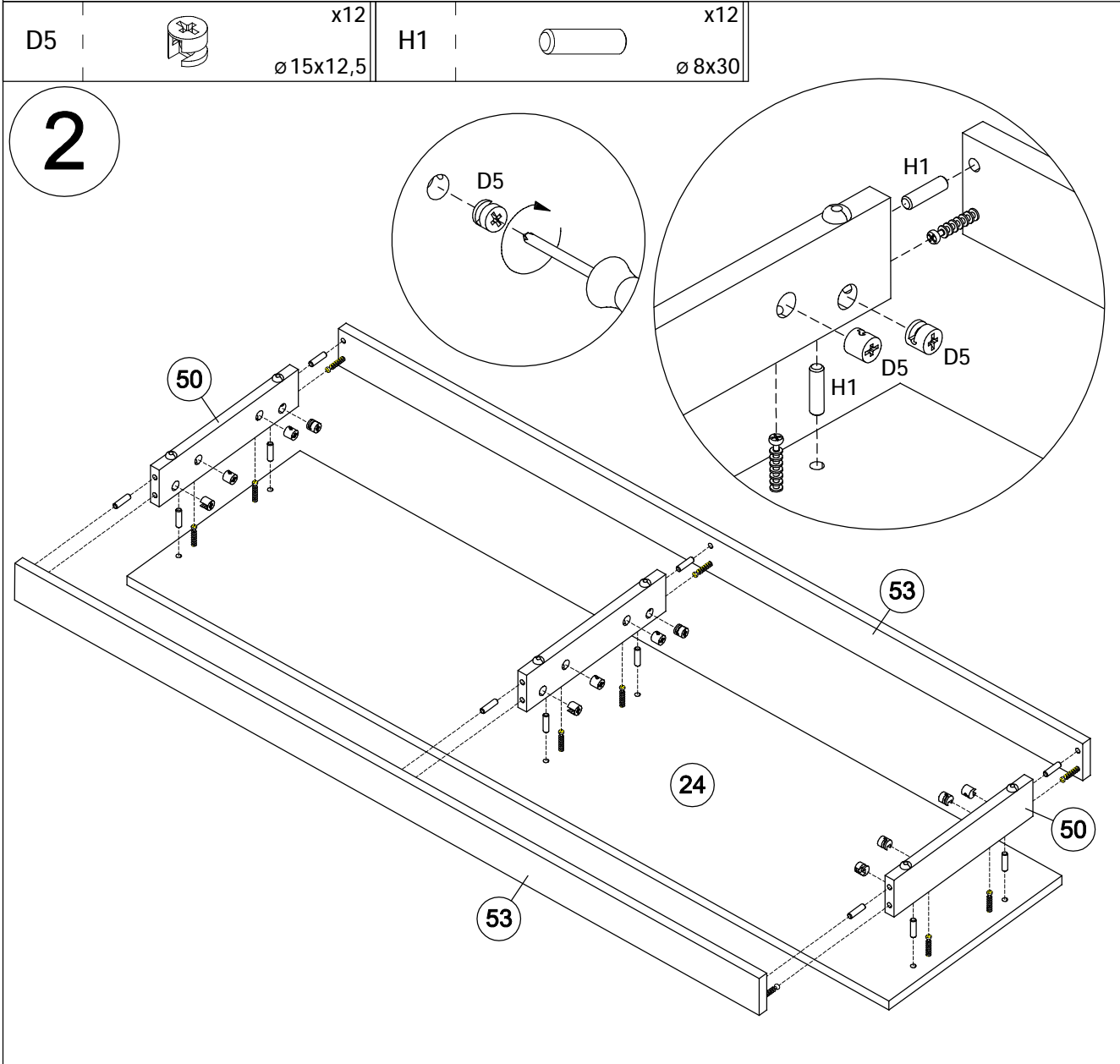
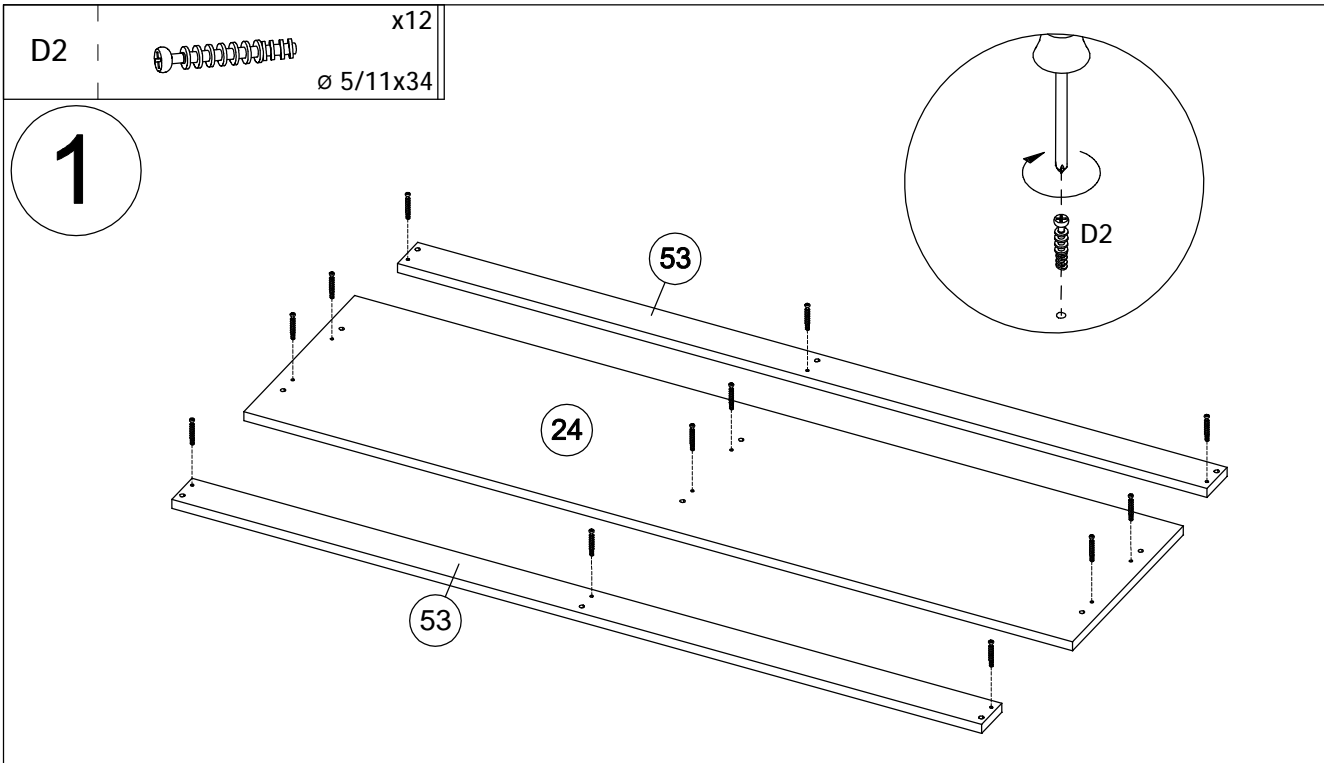

67286-1 67286-2

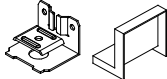

67286-1 67286-2

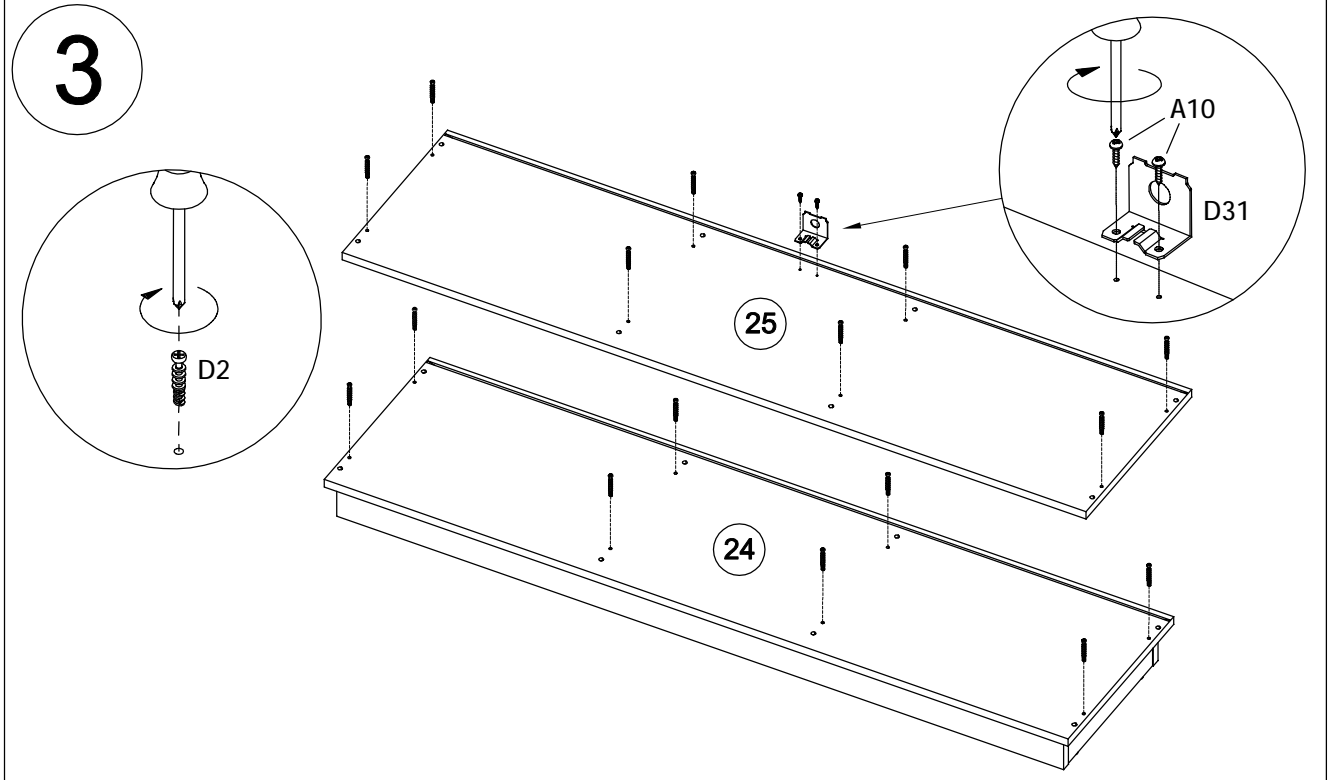

D2	 x16 ø 5/11x34	D31	 x1	A10	 x2 ø 4x16
----	--	-----	--	-----	--

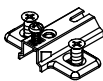

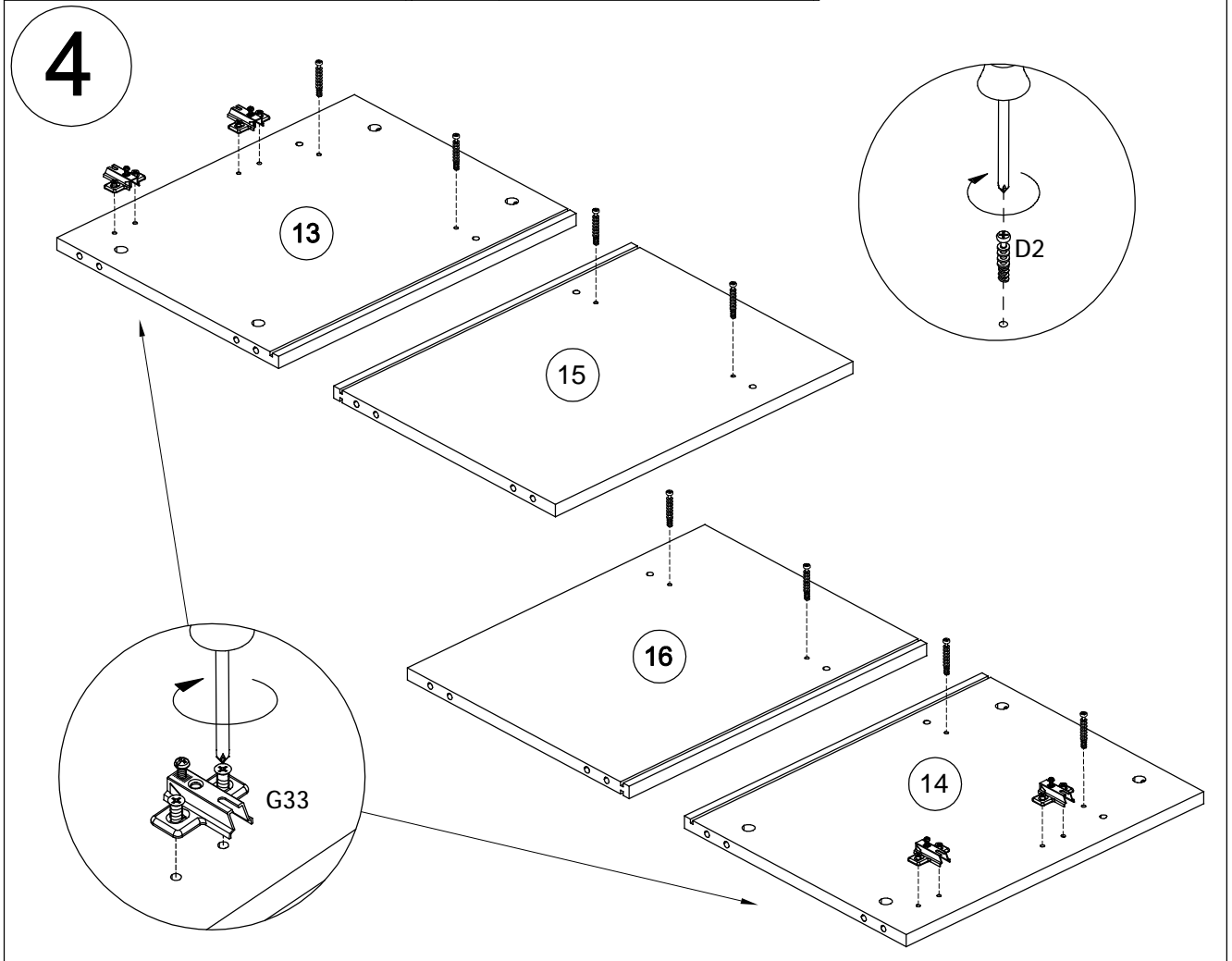



D2	 x8 ø 5/11x34	G33	 x4
----	---	-----	---

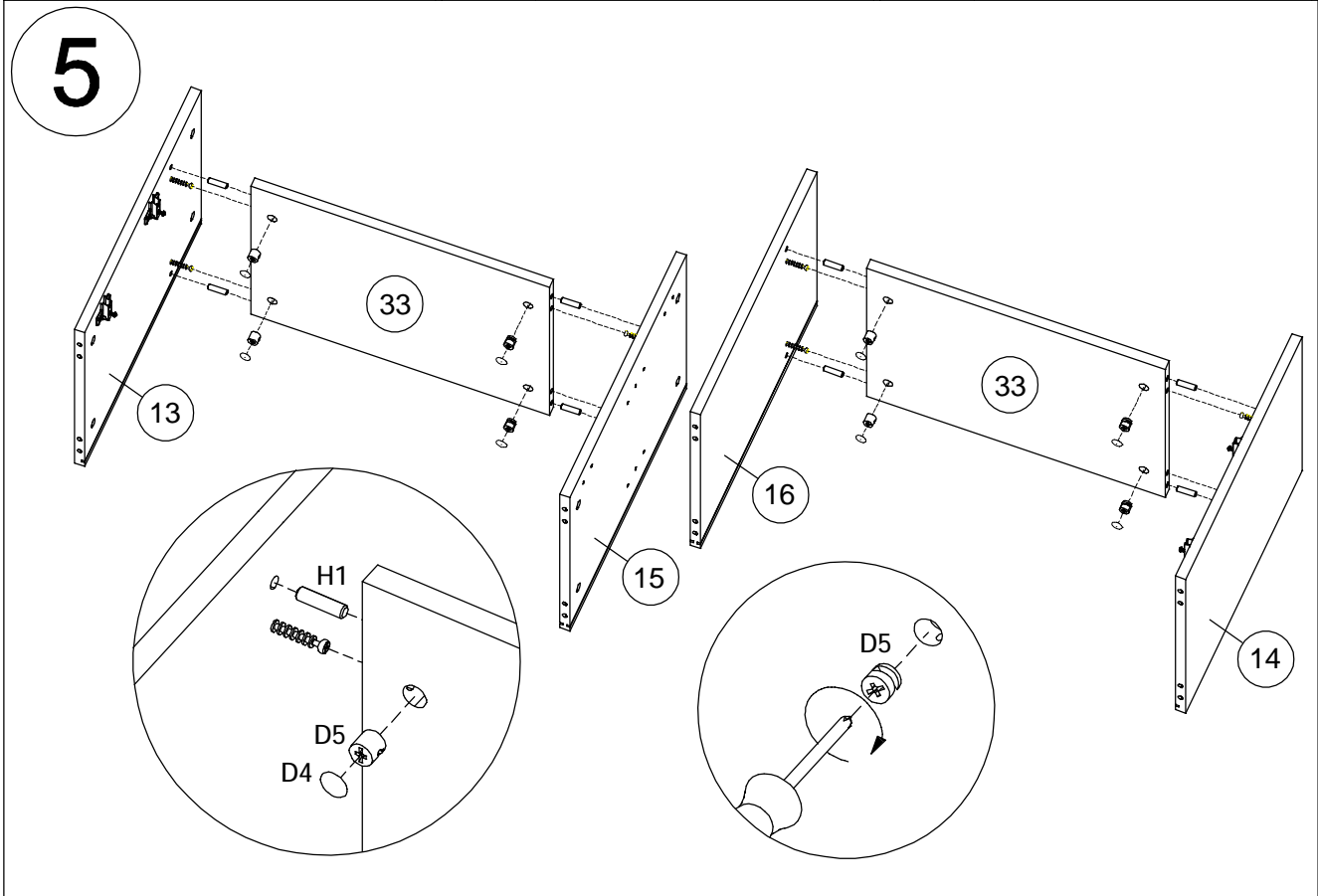

67286-1 67286-2

H1		x8 ø 8x30	D5		x8 ø 15x12,5	D4		x8 ø 17
----	---	--------------	----	---	-----------------	----	---	------------



H1		x16 ø 8x30	D5		x16 ø 15x12,5	D4		x16 ø 17
----	---	---------------	----	---	------------------	----	---	-------------

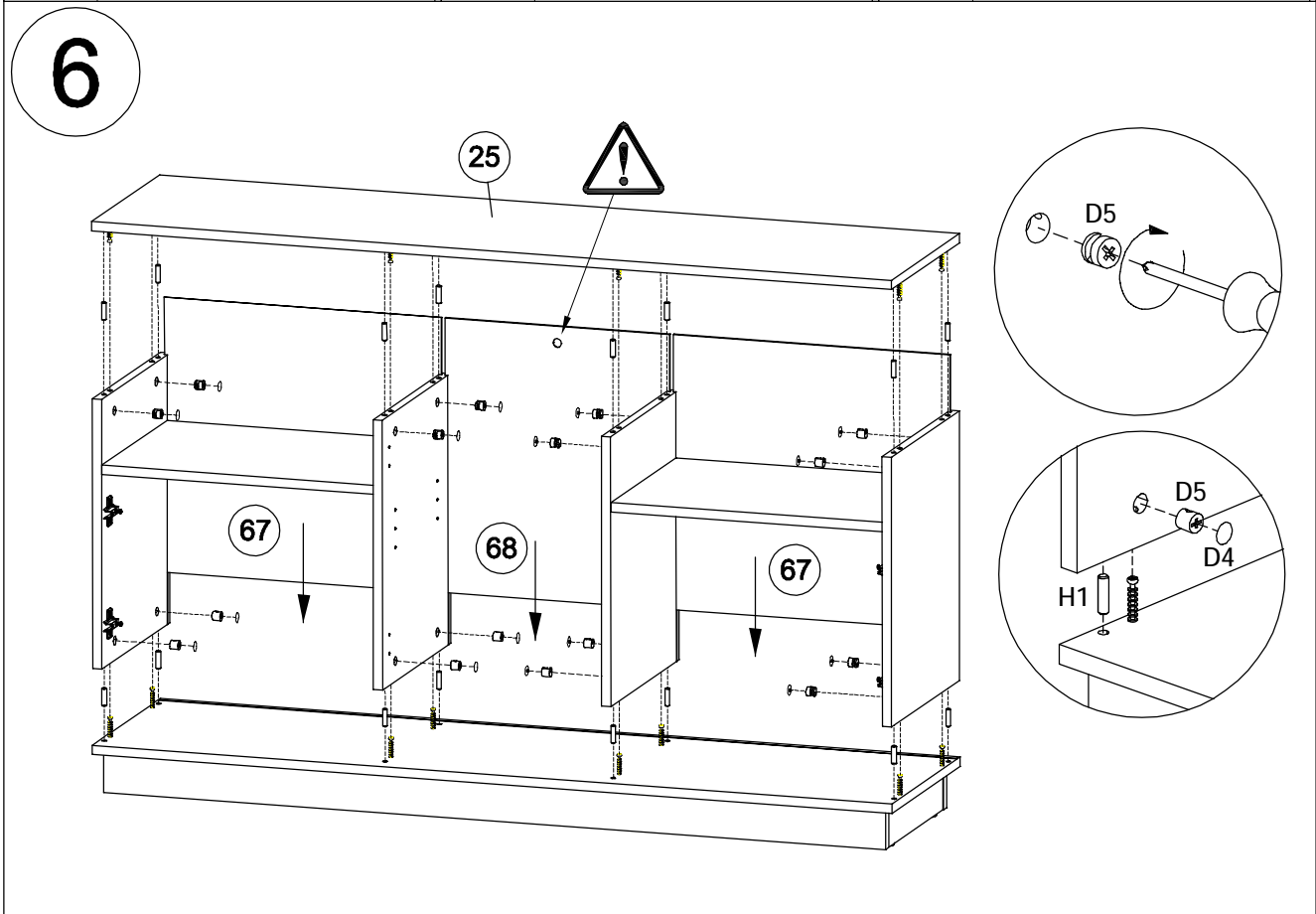

67286-1 67286-2

D36



x12

7

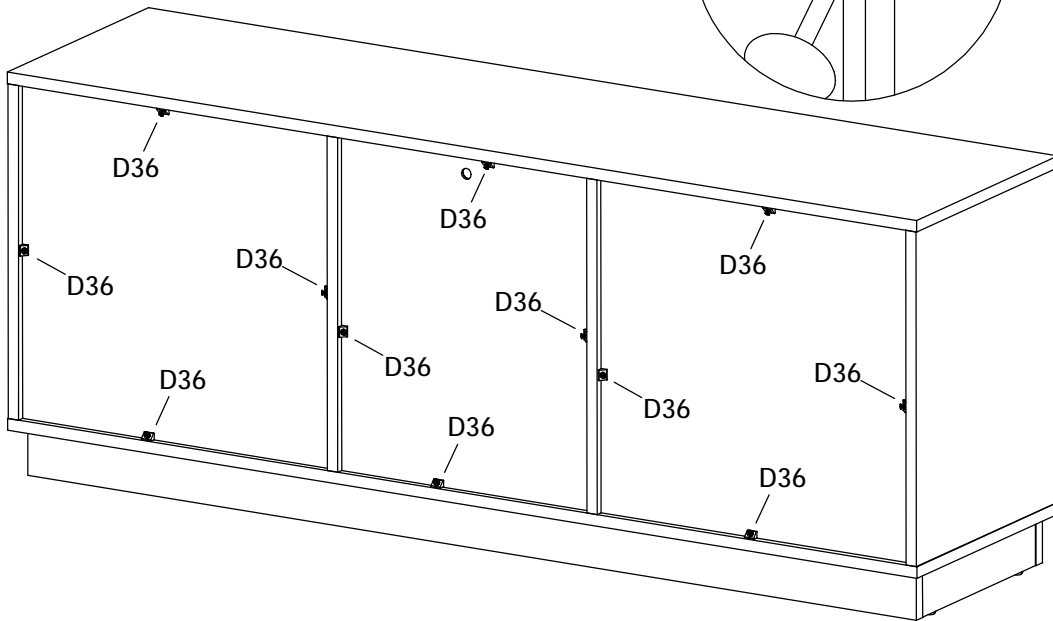
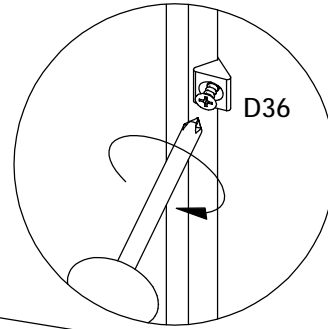

D31

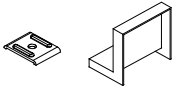

x1

H8

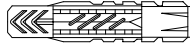

x1

A69

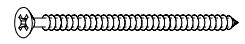

x1

ø 6x35

ø 4x60

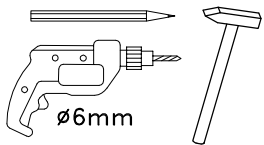
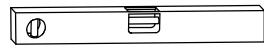

8

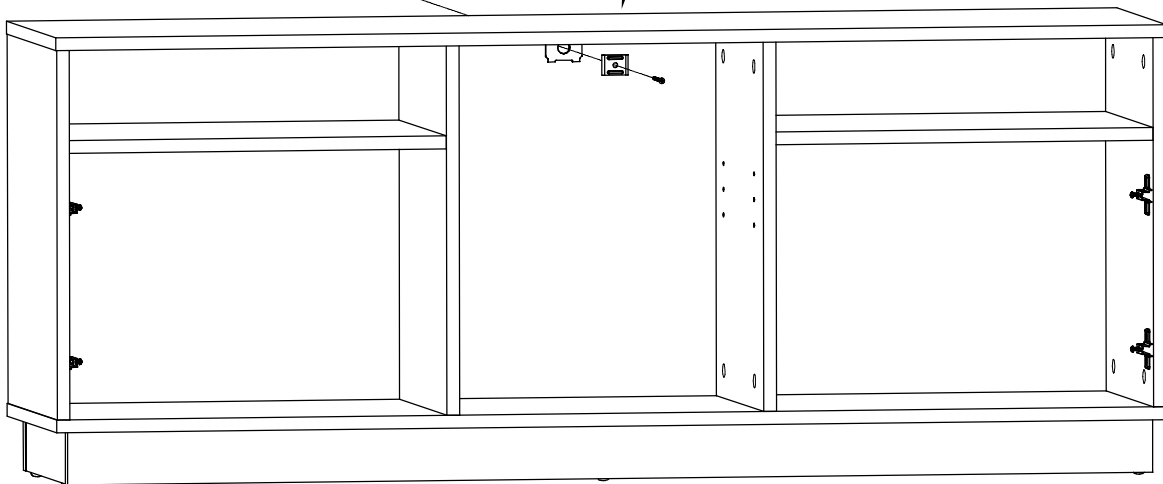
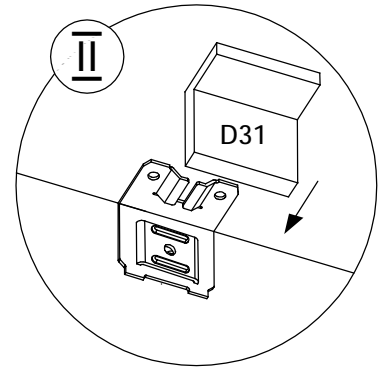
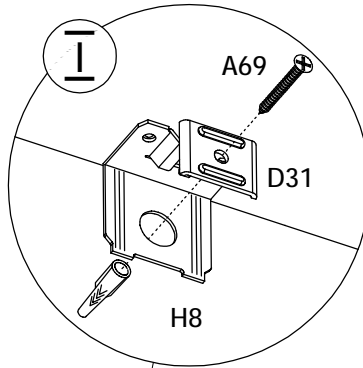

ø6mm

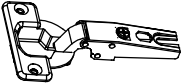

67286-1 67286-2

G39		x4 ∅ 35	G40		x2 ∅ 35	A65		x12 ∅ 4x17
-----	---	------------	-----	---	------------	-----	---	---------------

9

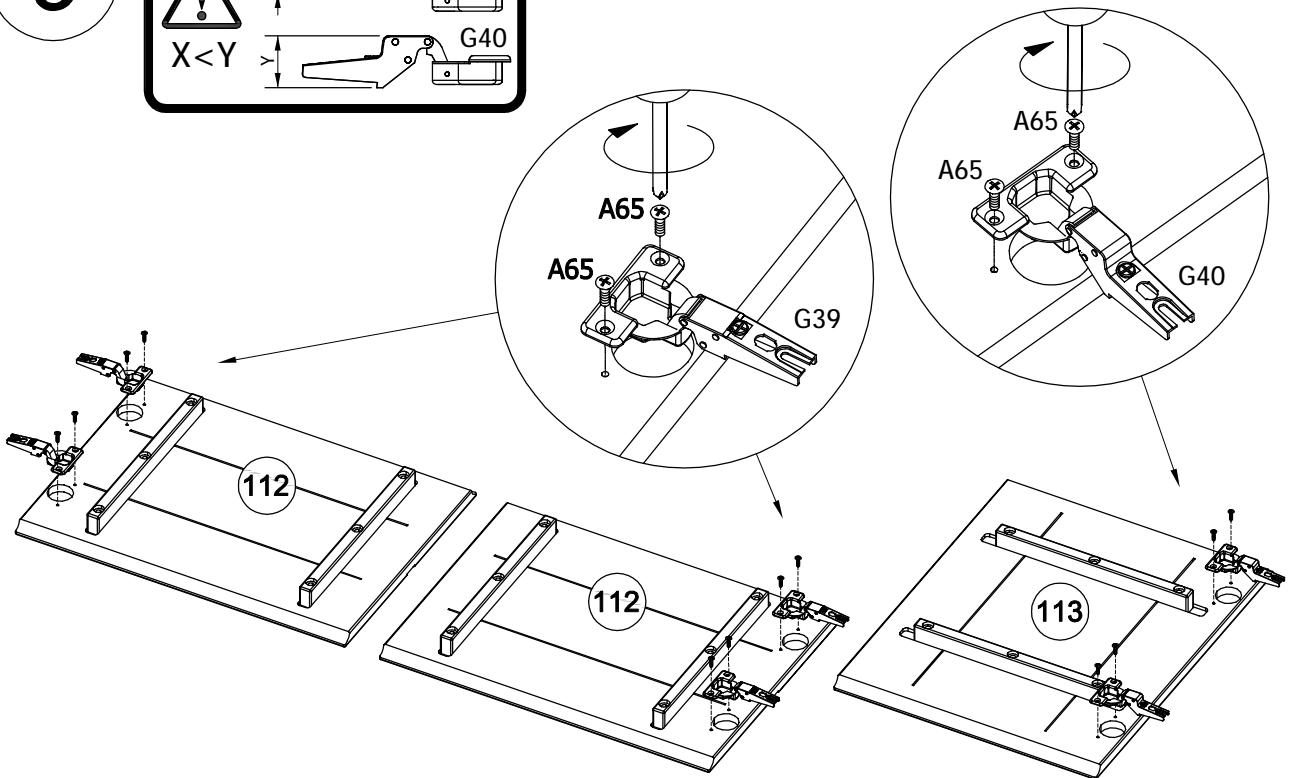
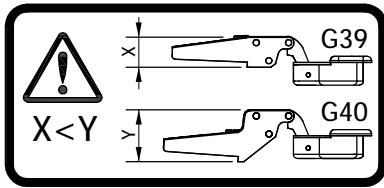

10

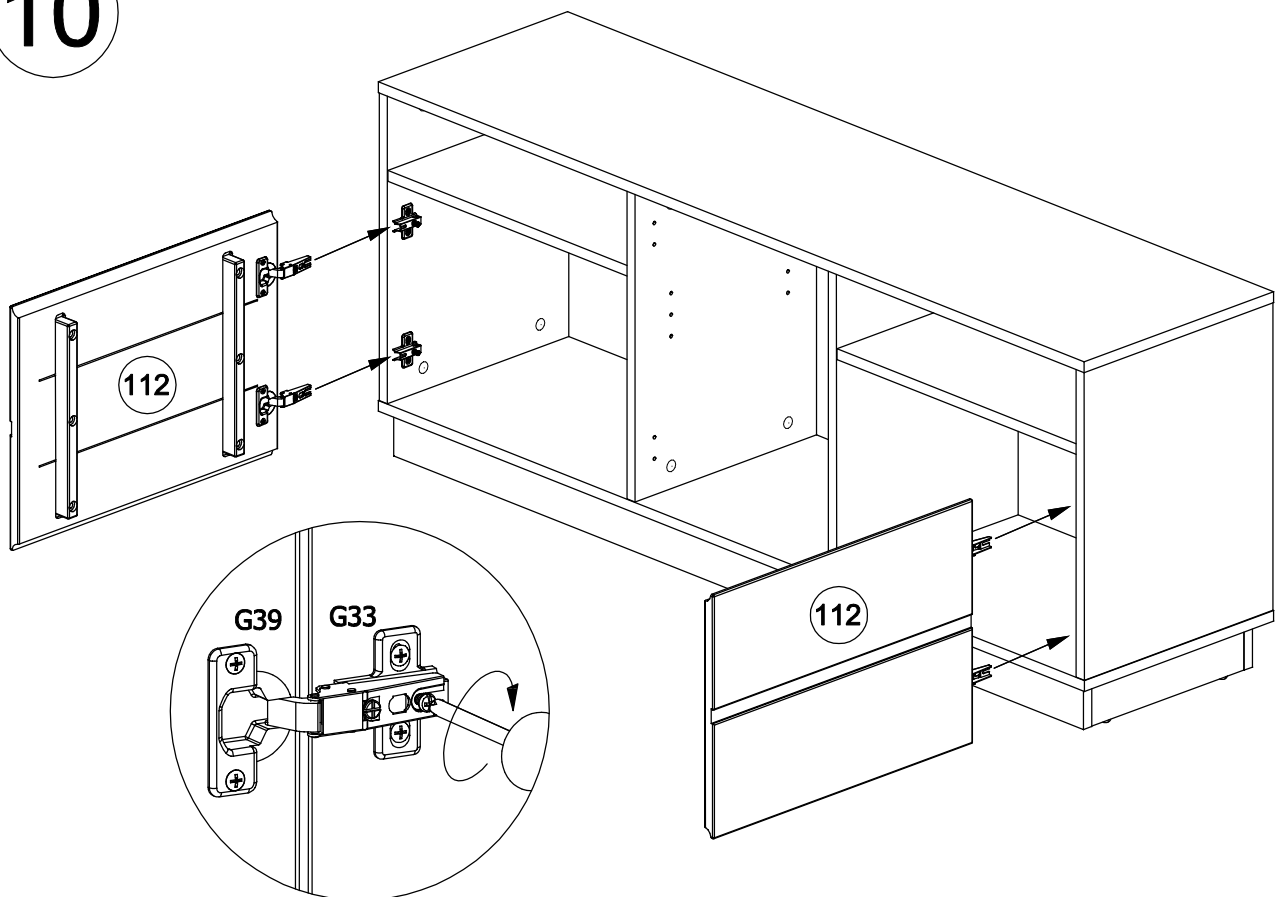

67286-1 67286-2

G33

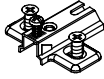

x2

11

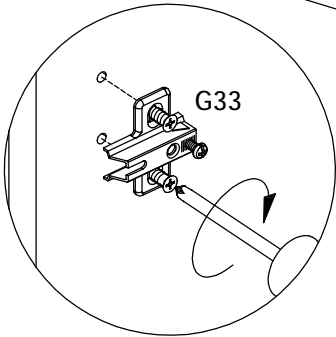
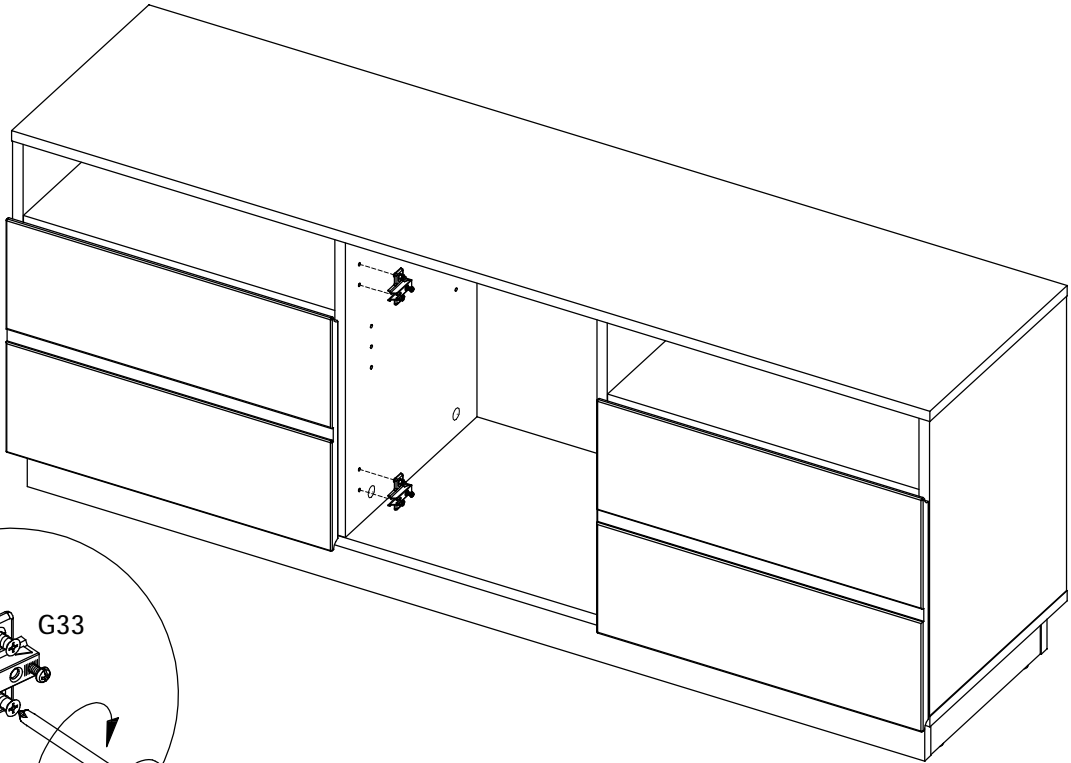

12

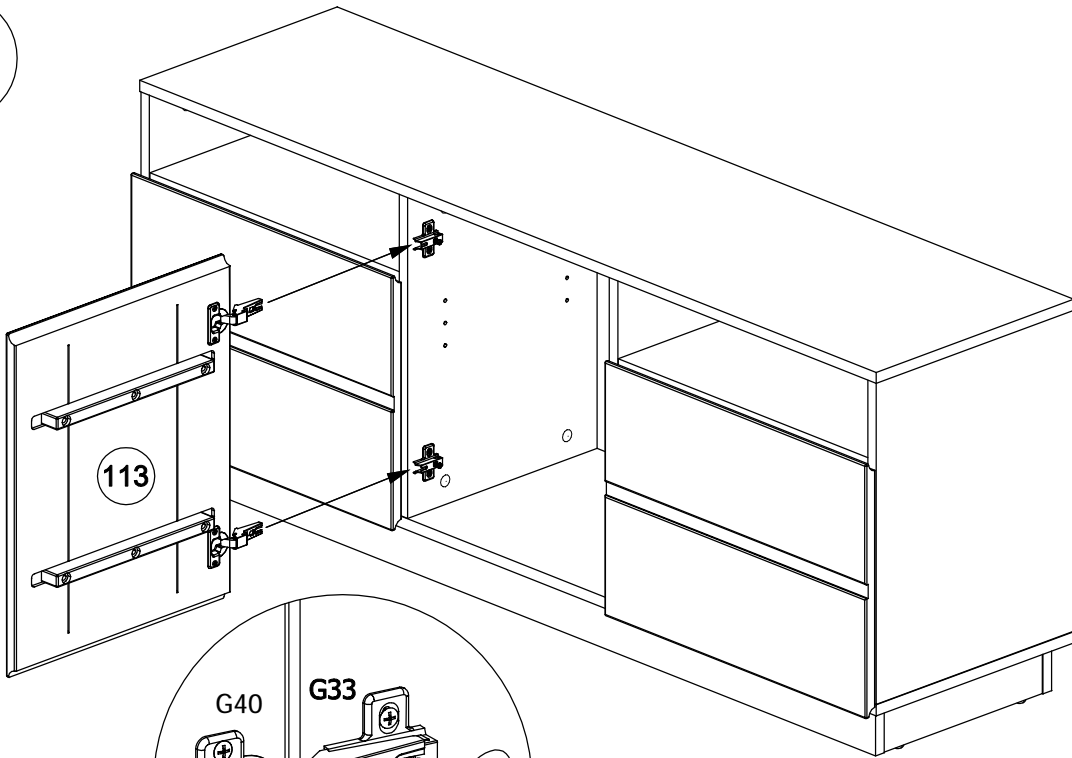

113

G40

G33

67286-1 67286-2

D1



x4

13

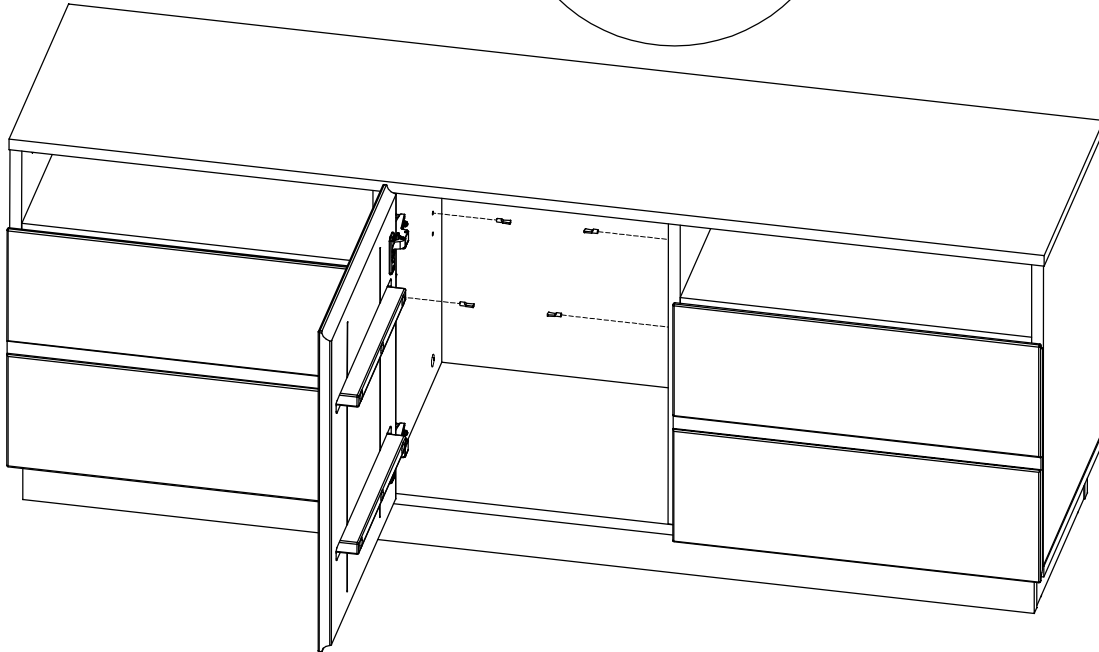
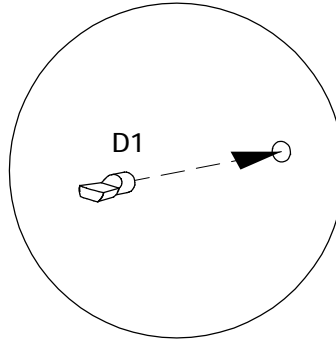

14

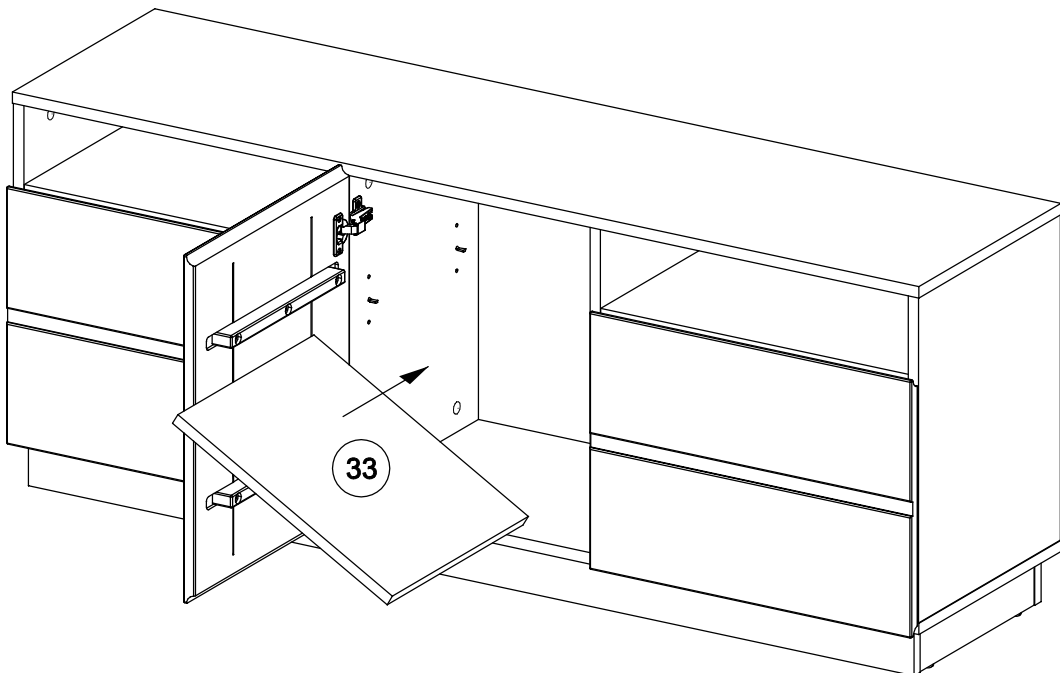

67286-1 67286-2

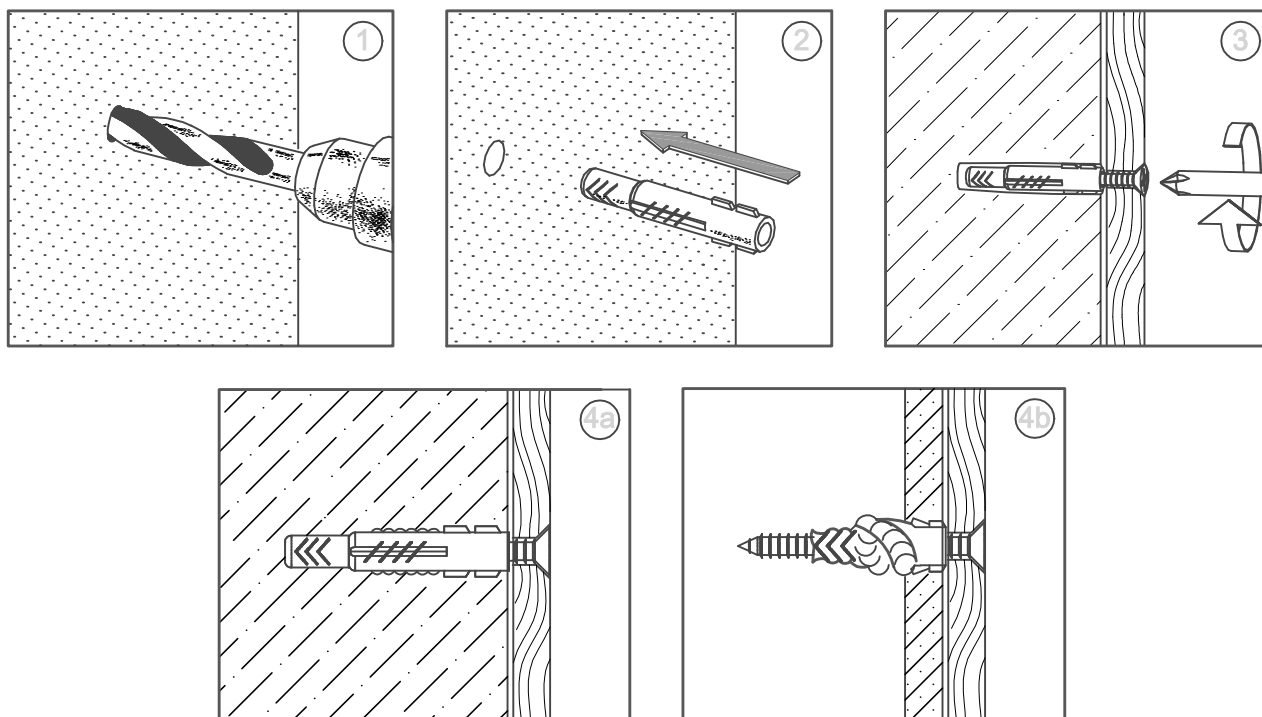
H8 A69 
ø4x60 ø6mm

- D** **Achtung:** Die Befestigung des Möbelstückes an der Wand muss von einer fachkundigen Person vorgenommen werden, da für die Montage an die Wand angepasste Dübel erforderlich sind.
- GB** **Attention:** A qualified professional is required when mounting furniture to the wall since dowels corresponding to the wall are required for this.
- FR** **Attention :** La fixation du meuble contre le mur doit être effectuée par une personne compétente car, pour le montage mural, il faut utiliser des chevilles adaptées.
- IT** **Attenzione:** Il fissaggio del mobile alla parete deve essere eseguito da persone esperte, dato che occorrono tasselli adeguati.
- NL** **Opgelet:** een vakkundige persoon dient het meubelstuk aan de muur te bevestigen; voor de montage aan de muur zijn immers aangepaste pluggen vereist.
- PL** **Uwaga:** Mocowanie mebla do ściany mogą przeprowadzić wyłącznie wykwalifikowane osoby, z uwagi na zastosowanie odpowiednio dopasowanych kołków do rodzaju ściany.
- CZ** **Pozor:** Montáž nábytku na stěnu musí provést odborník, protože k montáži na stěnu jsou zapotřebí upravené hmoždinky.
- SK** **Pozor:** Upevnenie nábytku na stenu musí vykonať odborník, nakoľko sú pre montáž na stenu potrebné vhodné hmoždinky.
- HU** **Figyelem:** A bútorelemek falra rögzítését szakembernek kell végeznie, mert a rögzítéshez megfelelő tiplit kell használni.
- RO** **Atenție:** Fixarea la perete a piesei de mobilier se realizează numai de către personal competent, deoarece montajul de perete necesită dibluri adecvate.
- TR** **Dikkat:** Mobilya parçasının duvara sabitlenmesi, duvar montajı için özel uyarlanmış dübeller gerektirdiğinden bu iş sadece bu konuda uzman bir kişi tarafından gerçekleştirilmelidir.
- RU** **Внимание:** Поскольку для монтажа на стене необходимо использовать специальные дюбели, мебель должна быть закреплена на стене квалифицированным персоналом.

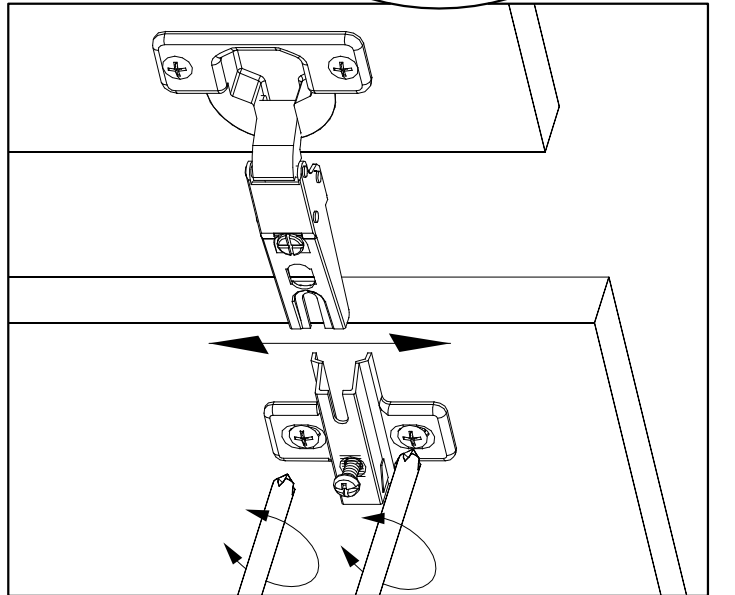
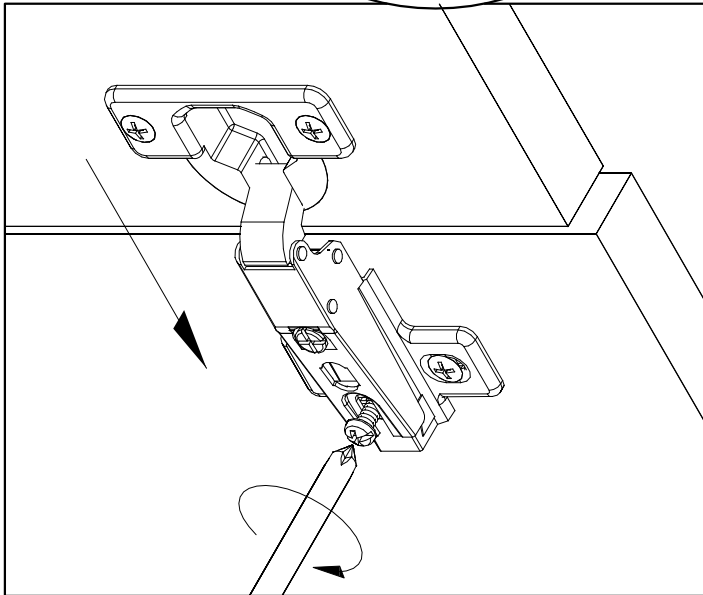
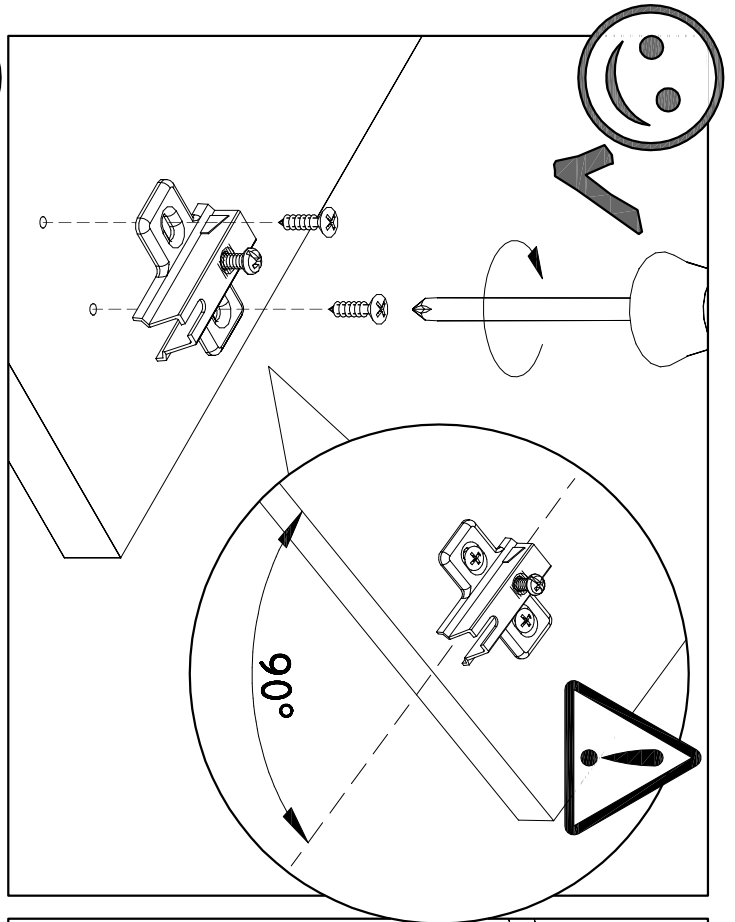
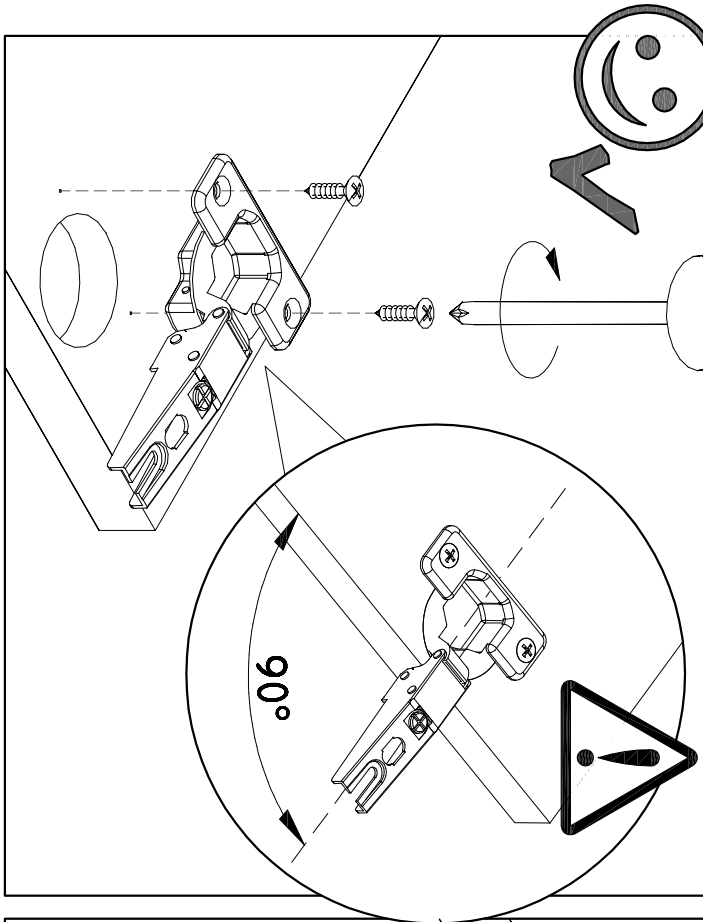
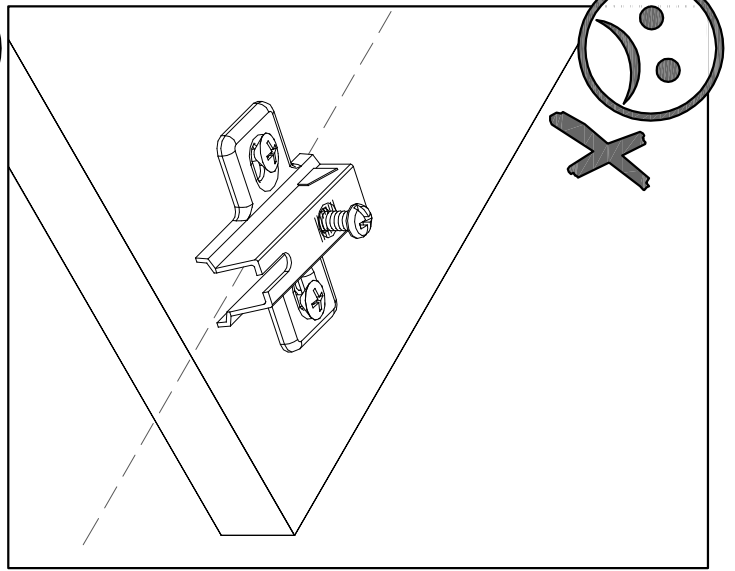
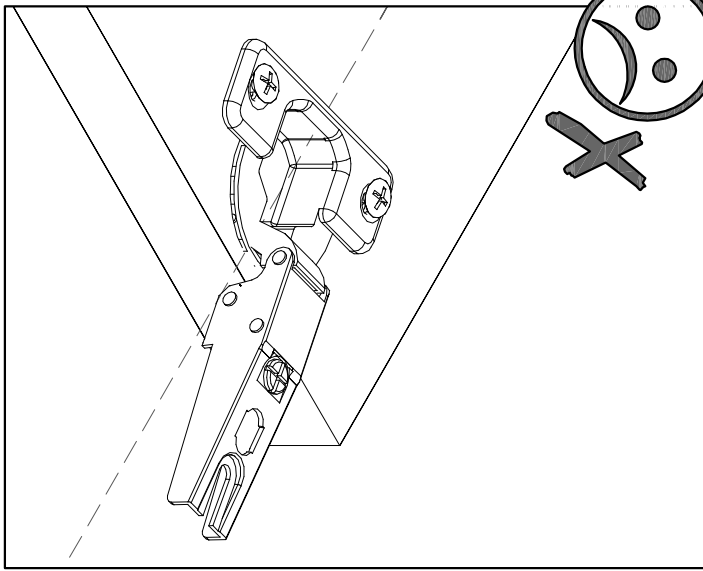

- (CZ) Úprava dveří
 (D) Das Richten einer Türe
 (F) Réglage d'une porte.
 (HU) Beállítása egy ajtó
 (I) Regolare una porta
 (LV) Durvju regulēšana
 (NL) Instellen van een deur
 (PL) Regulacja drzwi
 (RO) Reglarea o ușă
 (RU) Регулировка дверей
 (SK) Úprava dverí
 (TR) Bir kapı ayarlamama
 (UK) Adjusting a door
 (FIN) Oven säätö

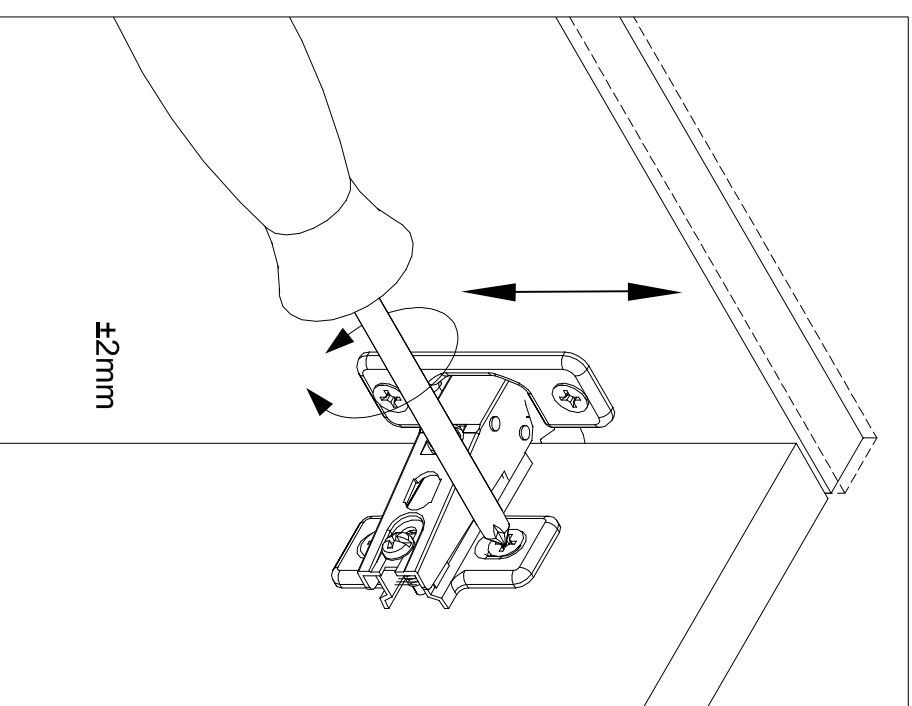
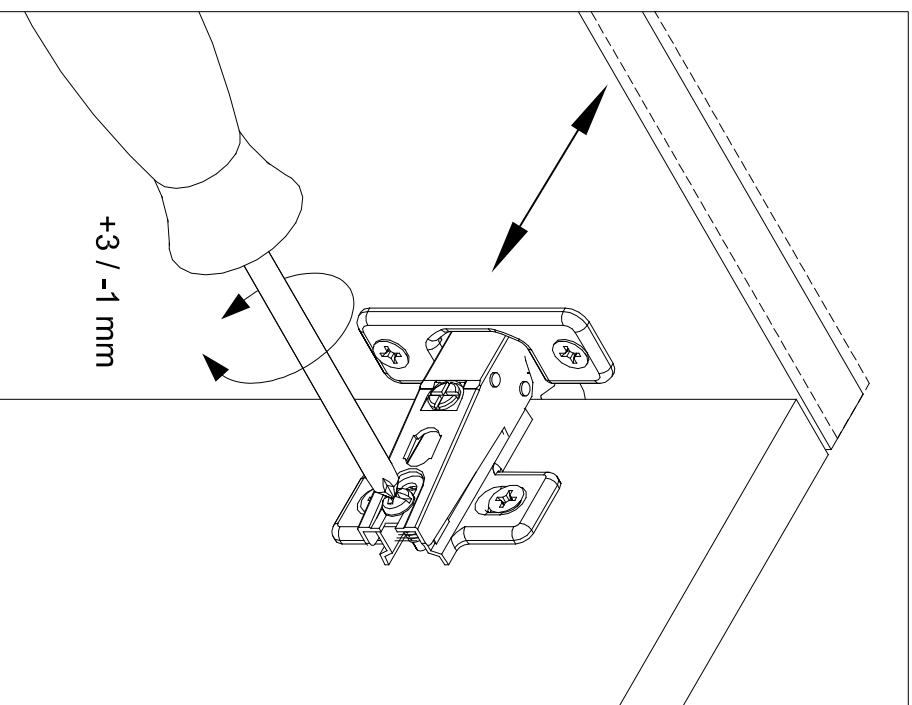
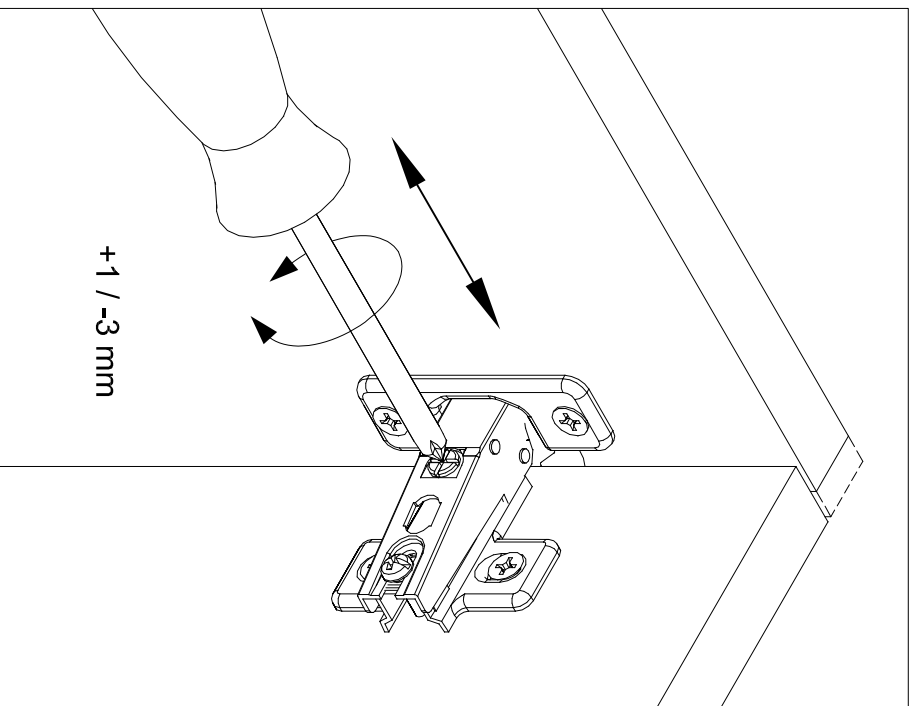

Liebe Kundin,
lieber Kunde,

(DE)

da Möbel aus Naturholz ständigen Klima- und Feuchtigkeitsschwankungen ausgesetzt sind, können die massiven Fronten ihre Maße ändern (quellen oder schwinden) oder sich verziehen. Die genannten Veränderungen sind bei massiven Holzteilen ein normaler Prozess. Es sind keine Qualitätsmängel und kein Grund für eine Ersatzteilbestellung.

Dieses Schema zeigt Ihnen die Schritte zum Ausrichten der Massivholzfronten.

Chère cliente,
cher client,

(FR)

Comme les meubles en bois naturel sont sans cesse soumis aux variations climatiques et d'humidité, les dimensions des fronts en bois massif peuvent changer (gonfler ou rétrécir) ou bien se rétracter. Les modifications citées sont un processus normal pour les pièces en bois massif. Ce ne sont pas des défauts de qualité et ne justifient pas de commande de pièces de rechange.

Ce schéma vous montre les étapes pour agencer les fronts en bois massif.

Dear customer,

(GB)

As natural wood furniture is exposed to constant climactic changes and fluctuating humidity, the solid wood front panels may change their dimensions (they may expand or shrink) or warp. The aforementioned changes are a normal process typical of solid wood components. This is not indicative of inferior quality and does not constitute a reason for ordering spare parts.

This schematic provides you with the steps for aligning solid wood front panels.

Alle Schrauben lockern

Desserrer toutes les vis.

Loosen all screws.

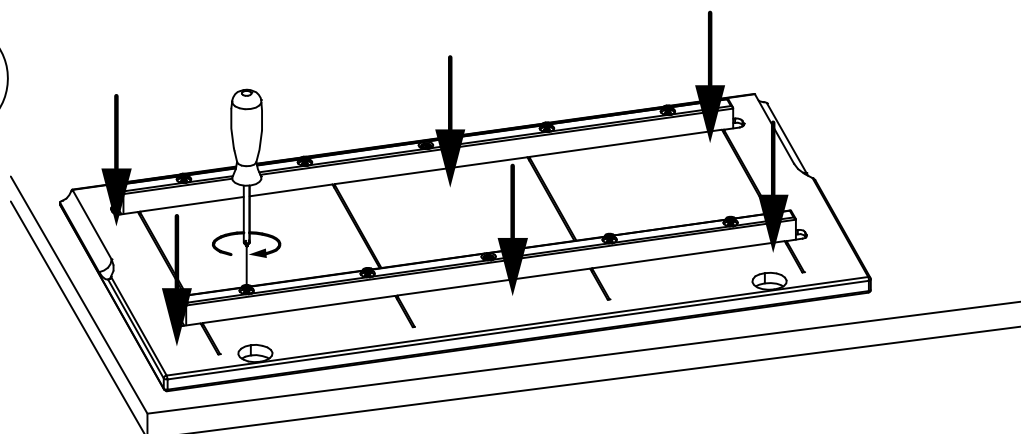
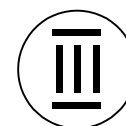
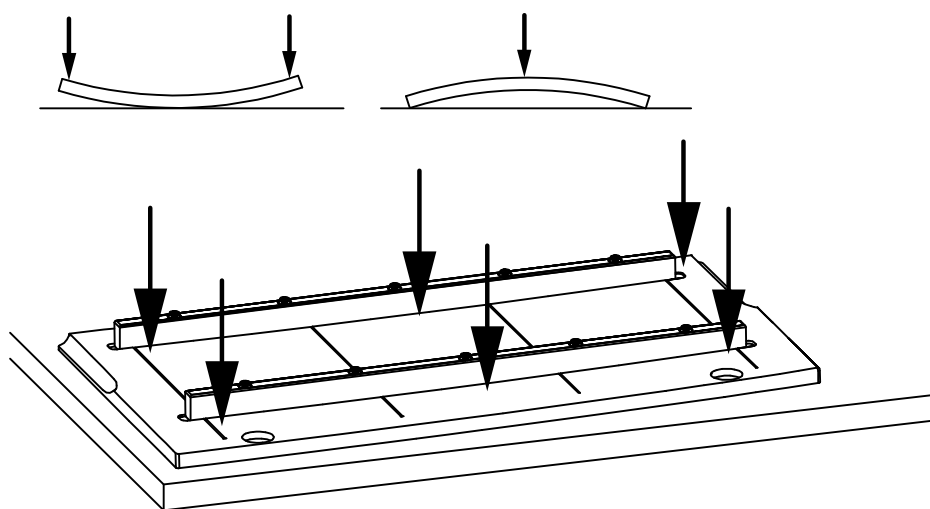
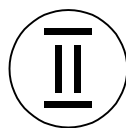
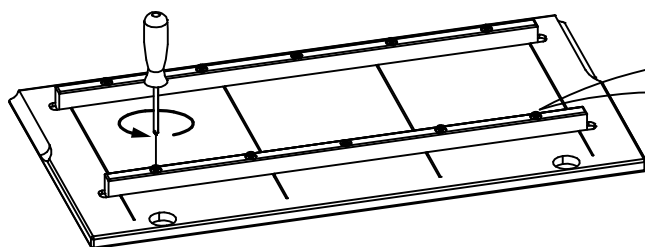
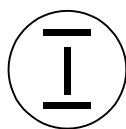

Schrauben wieder festdrehen

Resserrer les vis.

Tighten all screws again.

Gentili clienti,

IT

dato che i mobili in legno naturale patiscono i continui sbalzi di temperatura e umidità, le massicce parti frontali possono mutare dimensione (gonfiarsi o restringersi) oppure contrarsi. Tali mutamenti sono un fenomeno normale delle parti di legno massiccio. Non rappresentano quindi difetti di lavorazione e non sono motivo d'urgente ordine sostitutivo.

Il presente schizzo vi mostra i passi per allineare le parti frontali in legno massiccio.

Beste klant,
Beste klant,

NL

Aangezien meubelen van natuurhout blootgesteld zijn aan voortdurende klimaat- en vochtigheidsschommelingen, kunnen de massieve voorkanten van afmeting veranderen (zwellen of krimpen) of worden vervormd. De genoemde wijzigingen vormen bij massieve houten stukken een normaal proces. Het zijn geen kwaliteitsgebreken en ze geven geen reden tot bestelling van vervangstukken.

Dit schema toont u de stappen voor het justeren van massieve houten voorkanten.

Дорогая клиентка,
Дорогой клиент,

RU

Так как мебель, изготовленная из натурального дерева, постоянно подвержена изменению климатических условий, а также влажности, то при значительных изменениях её габариты могут измениться (набухание или уменьшение) или сморщивание. Названные изменения представляют из себя нормальный процесс для массивных частей из древесины. Это не недостатки качества и не причина для замены.

На этой схеме представлены шаги для рихтования фронтальных частей массивной древесины.

Allentare tutte le viti.

Alle schroeven losmaken.

Следует расслабить все винты.

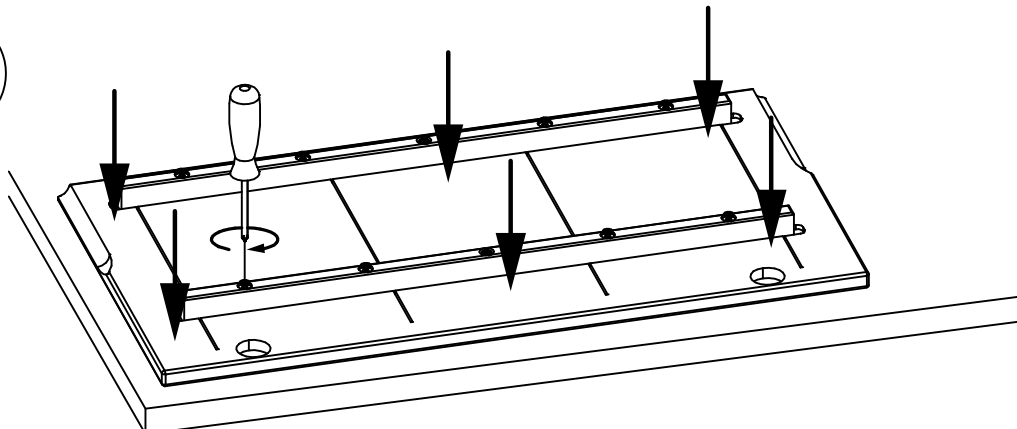
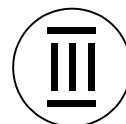
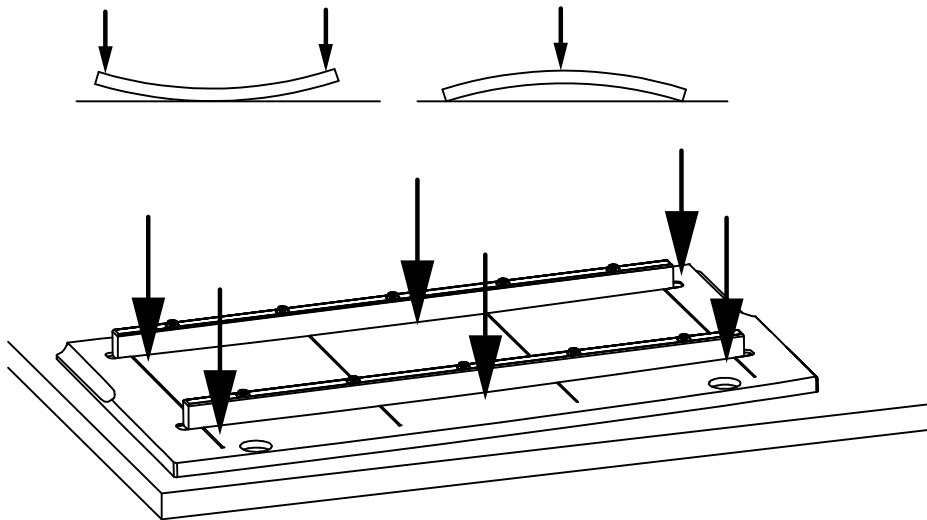
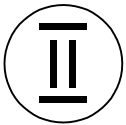
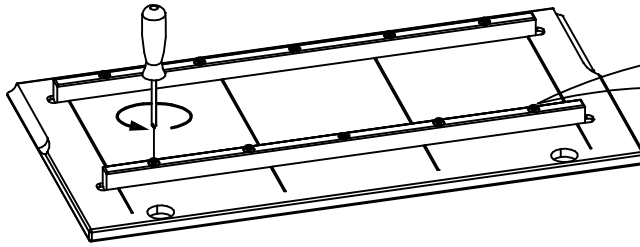
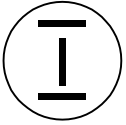

Serrare nuovamente le viti.

Schroeven opnieuw vastdraaien.

Винты следует опять завинтить.

Vážená zákaznice,
vážený zákazníku,

(CZ)

protože je masivní nábytek vystaven neustálému klimatu a vlhkosti, může tento masivní přední díl změnit svoje rozměry (zvětšit nebo zmenšit se) nebo se pokrivit. Výše uvedené změny jsou pro masivní dřevo obvyklým procesem. Nejedná se o žádné problémy s kvalitou tj. bez potřeby objednání náhradních dílů.

Toto schéma ukazuje kroky pro vyrovnání masivních dřevěných předních částí.

Kedves Vásárlónk!

(HU)

A természetes fából készült bútor folyamatosan ki van téve a hőmérséklet- és páratartalom-változásoknak, így a tömör előlapok megváltoztathatják alakjukat (pl. megdagadhatnak vagy vetemedhetnek). Ezek a változások a természetes alapanyagok esetén teljesen normálisak. Az ilyen változások nem jelentenek minőségügyi problémát, miattuk nem kell egyes elemeket lecserélni.

A sablon a tömörfa előlap kivágásának lépéseit ismerteti.

Droga Klientko,
drogi Kliencie,

(PL)

zważywszy na to, że meble wykonane z drewna naturalnego cały czas są narażone na wahania warunków klimatycznych i zmiany wilgotności, wymiary frontów z drewna litego mogą ulec odkształceniu (pęcznieniu lub skurczeniu) lub wypaczeniu. W przypadku części wykonanych z drewna litego tego typu zmiany uznaje się za normalny proces. Zmiany te nie są brakami jakościowymi i w związku z tym nie stanowią podstawy do zamówienia części zamiennych.

Przedmiotowy schemat przedstawia kolejne kroki, jakie należy wykonać w celu wyrównania frontów wykonanych z drewna litego.

Uvolněte všechny šrouby.

Minden csavart lazítson meg.

Poluzować wszystkie śruby.

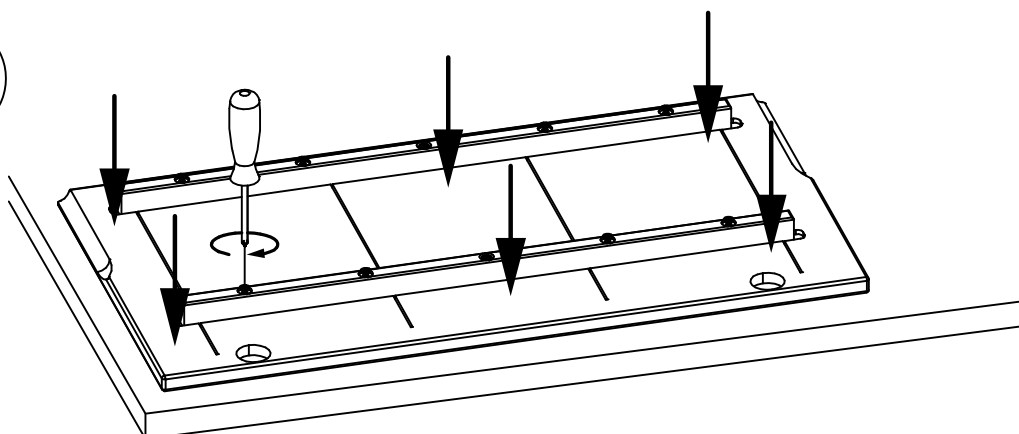
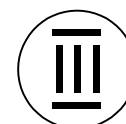
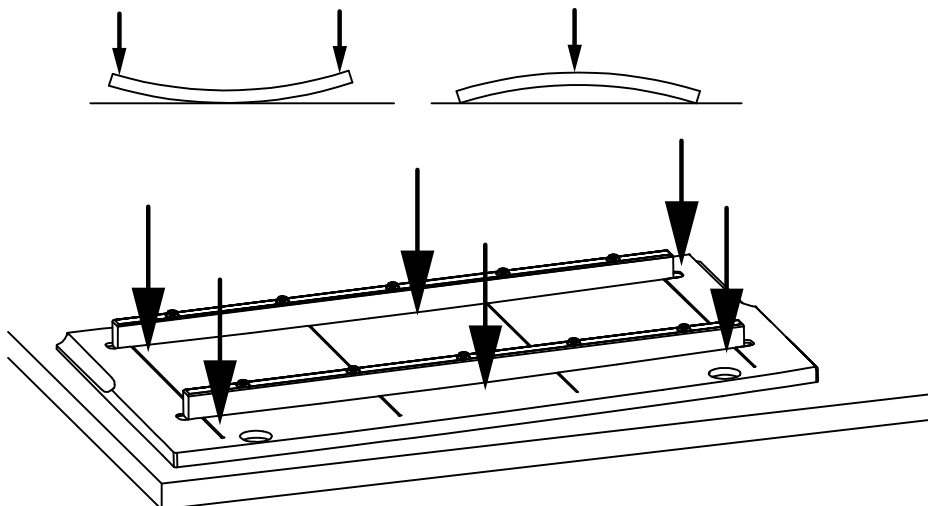
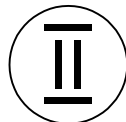
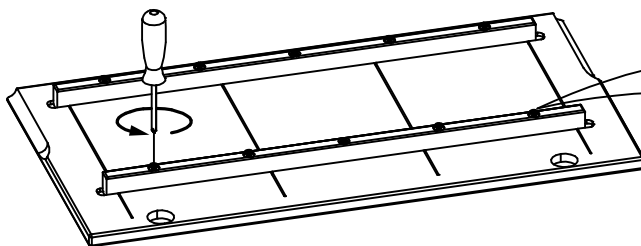
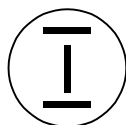

Opětovně utáhněte všechny šrouby.

Húzza meg újra a csavarokat.

Ponownie dokręć śruby.

Stimată clientă,

RO

deoarece mobilierul din lemn natural este expus permanent variațiilor de climă și umiditate, este posibil ca părțile masive ale acestuia să își modifice dimensiunile (umflări sau contracții) sau să prezinte deformații. Pentru elementele din lemn masiv, modificările menționate constituie un proces normal. Ele nu sunt considerate deficiențe din punct de vedere a calității și nu constituie obiectul pentru comandarea de piese de schimb.

Această schemă vă indică pașii procedurii de reglare a părților frontale din lemn masiv.

Vážená zákazníčka,
vážený zákazník,

SK

pretože je masívny nábytok vystavený neustálemu vzduchu a vlhkosti, môže tento masívny predný diel zmeniť svoje rozmery (zväčšiť alebo zmenšiť sa) alebo sa pokriviť. Uvedené zmeny sú pre masívne drevo obvyklým procesom. Nejedná sa o žiadne problémy s kvalitou, bez potreby objednania náhradných dielov.

Toto schéma ukazuje kroky pre vyrovnanie masívnych drevených predných častí.

Değerli Müşterimiz,

TR

masif ahşap mobilya, hava ve neme maruz kaldığından, bu nedenle bu neden olabilir boyut değişimi (artır veya büzülme), veya deforme. Yukarıda belirtilen değişiklikler normal bir süreçtir masif ahşap için. Bu, herhangi bir kalite sorunu değil ve yedek parça sipariş etmek için bir neden yoktur.

Bu şemada adımları gösterir masif ahşap parçaları nasıl hizalamak için.

Slăbiți toate șuruburile.

Uvoľnite všetky skrutky.

Tüm vidaları gevşetin.

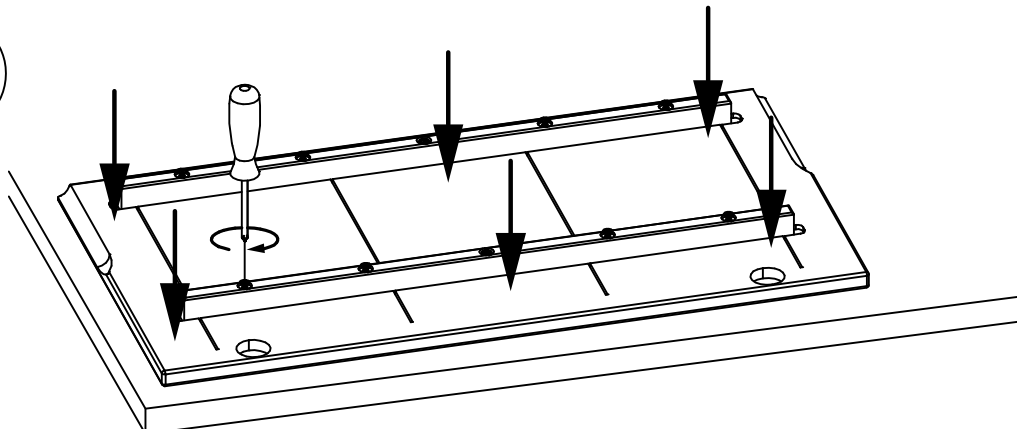
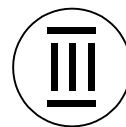
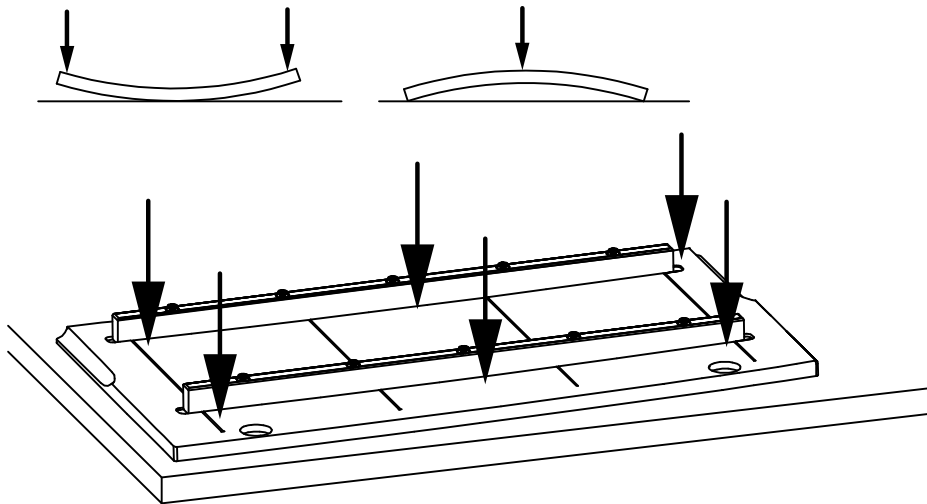
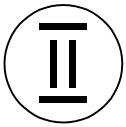
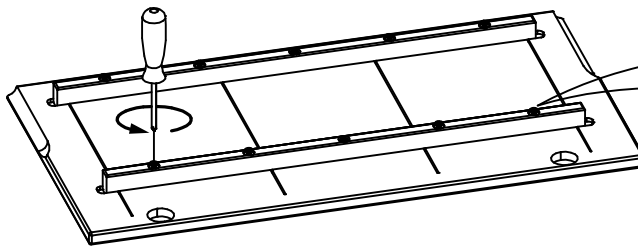
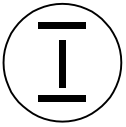

Strângeți la loc șuruburile.

Opätovne utiahnite všetky skrutky.

Vidaları tekrar sıkın.

Cienītais klient,

LV

Dabīgā koka mēbeles ir pakļautas mainīgiem klimata un mitruma apstākļiem. Masīvkoka fasādes paneļi var mainīt savus izmērus (uzbriest vai sarukt) vai vērpties. Šīs izmaiņas ir normāls process un ir raksturīgs masīvkoka detaļām. Tas nenorāda uz zemākas kvalitātes materiālu un tas nav iemesls, lai pasūtītu jaunas rezerves daļas.

Šajā shēmā ir parādītas darbības, kas soli pa solim palīdzēs veikt koka fasādes paneļu regulēšanu.

Visas skrūves atskrūvēt vajīgāk.

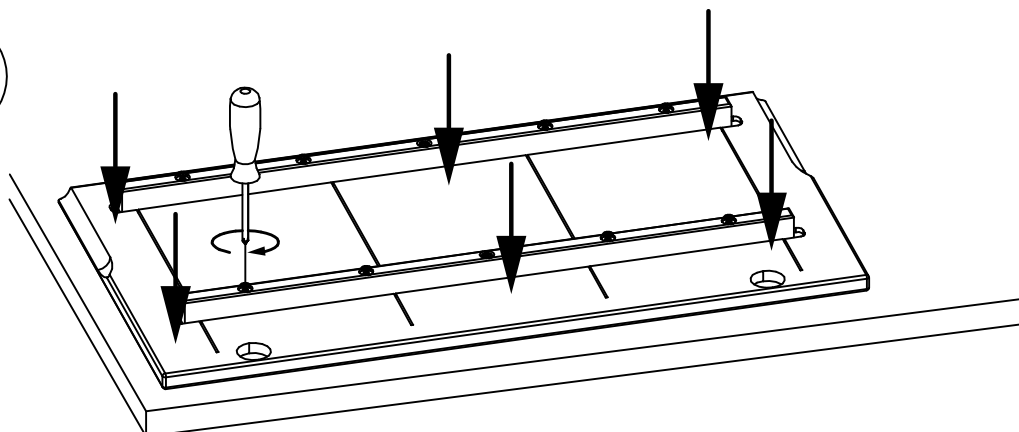
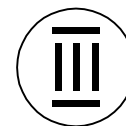
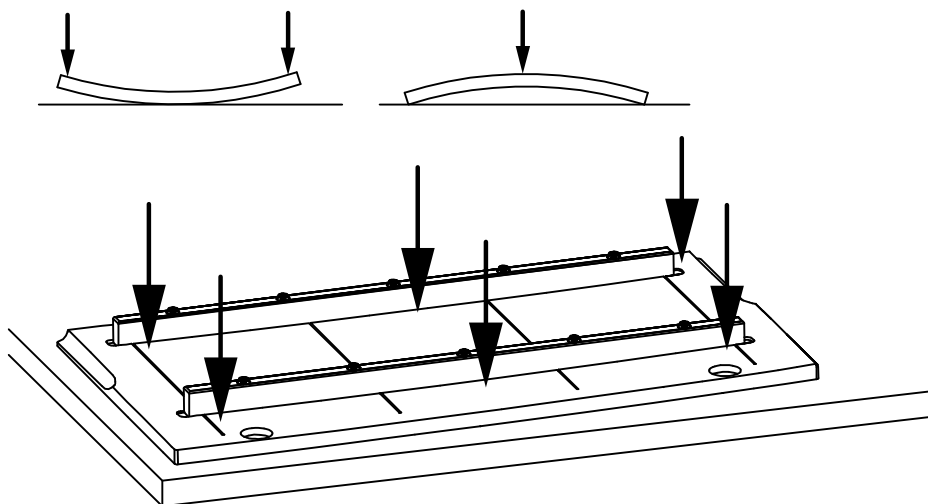
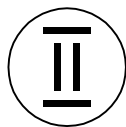
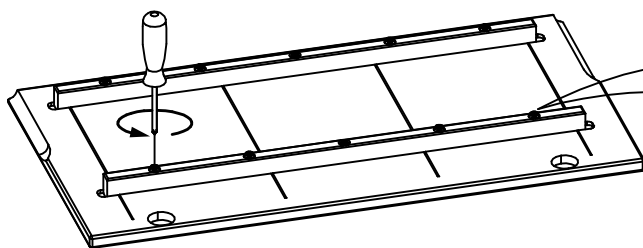
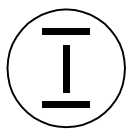

Visas skrūves pieskrūvēt ciešāk.