

# AVENTOS HF

Die Planungsmaße für SERVO-DRIVE für AVENTOS entnehmen Sie bitte den speziellen Planungsangaben. / Please see special installation instructions for installation dimensions for SERVO-DRIVE for AVENTOS. / Pour obtenir les mesures de planification pour SERVO-DRIVE pour AVENTOS, veuillez consulter les données de planification spéciales. / Per le misure di progettazione relative a SERVO-DRIVE per AVENTOS si prega di far riferimento alle indicazioni di progettazione specifiche. / Sacen las medidas de planificación para SERVO-DRIVE para AVENTOS de los datos especiales de planificación. / Wymiary planowania SERVO-DRIVE do AVENTOS znajdują Państwo w specjalnych instrukcjach.



Technische Änderungen vorbehalten / Subject to technical changes without notice / Modifications techniques réservées / Con riserva di modifiche tecniche e del programma di produzione / Sujeto a modificaciones técnicas sin previo aviso / Zmiany techniczne zastrzeżone

Julius Blum GmbH  
Beschlägefabrik  
A 6973 Höchst, Austria  
Tel.: +43 5578 705-0  
Fax: +43 5578 705-44  
E-Mail: [info@blum.com](mailto:info@blum.com)  
[www.blum.com](http://www.blum.com)

Planung symmetrisch / Planning symmetrical / Planification symétrique /  
 Progettazione simmetrico / Planificación simétrico / Planowanie symetryczne

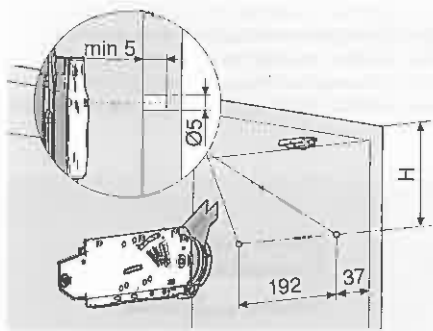

KH: 480-549 mm H: KH x 0.3 - 28 mm  
 KH: 550-1.040 mm H: KH x 0.3 - 57 mm

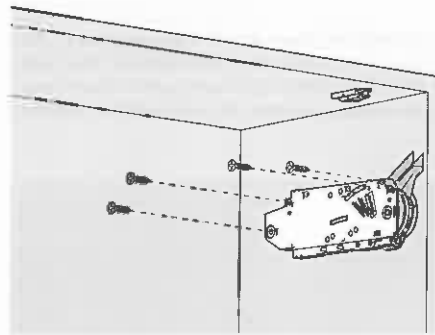

4 x Ø 4 x 35 mm

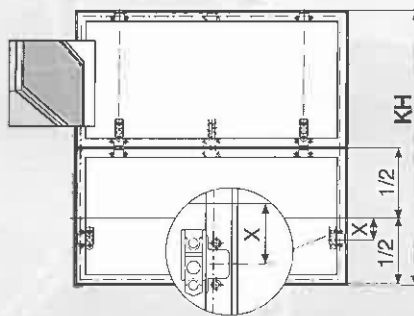
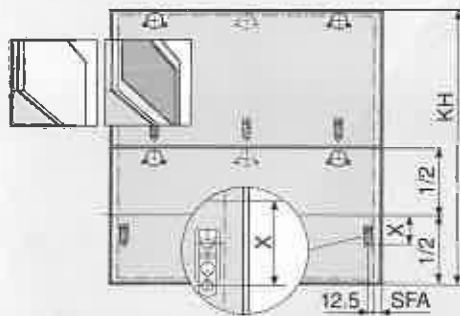
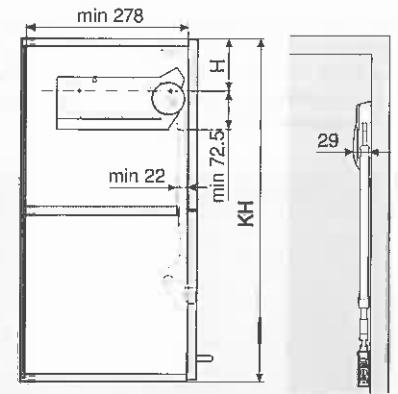

Ø 3.5 x 15 mm 609.1x00

Ø 3.5 x 6.5 mm 608.085

KH	X	X
480-549 mm	68 mm	70 mm
550-1.040 mm	45 mm	47 mm

KH	X
480-549 mm	54 mm
550-1.040 mm	31 mm

KB	FG
3 x 1.200-1.799 mm	12-19 kg
4 x 1.800 mm	≈ 20 kg

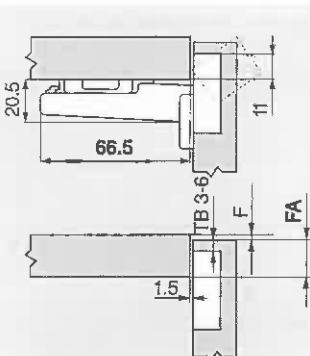

TB	FA
5	6 7 8 9 10 11 12 13 14 15 16 17
0	3 4 5 6
3	3 4 5 6
6	3 4 5 6
9	3 4 5 6

▲ MP

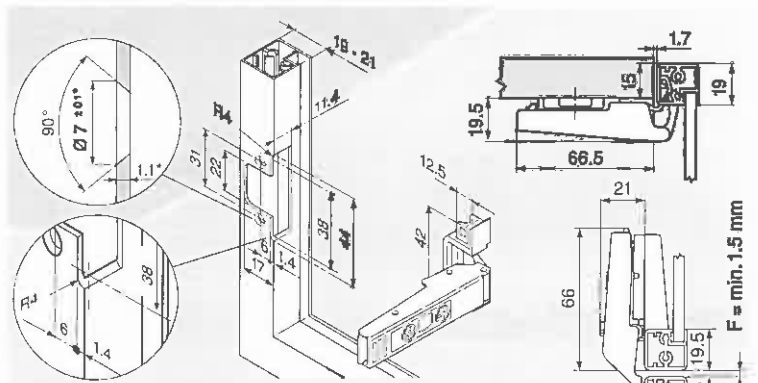

Ab 20,5 mm Rahmenstärke muss verstellt werden  
 An adjustment has to be made for frame thicknesses over 20.5 mm  
 Réglage nécessaire à partir d'une épaisseur de cadre de 20.5 mm  
 È necessaria una regolazione a partire da uno spessore del telaio di 20.5 mm  
 A partir de 20.5 mm resulta necesario ajustar el espesor del marco  
 Od grubości ramki 20.5 mm konieczne jest dopasowanie

\* Bei Veränderung der Materialsärke die Bearbeitungsmaße anpassen  
 When changing material thickness, adjust the assembly dimensions accordingly  
 En cas de modification de l'épaisseur du matériau, adapter les dimensions d'usinage  
 In caso di modifica dello spessore del materiale adattare la quota di lavorazione  
 Adaptar las medidas de elaboración a los distintos espesores del material  
 Przy zmianie grubości materiału dopasować wymiary obróbki

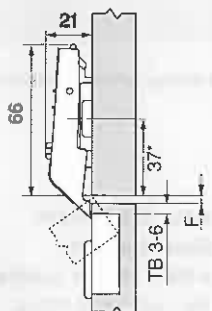

TB	F
0	3 4 5 6
3	6 5 4 3
6	
9	

▲ MP

\* KMP (37/32)

F	Fuge / gap / jeu / fuga / juego / Szczelina	FHo	Fronthöhe oben / Upper front height / Hauteur de face supérieure / Altezza frontale superiore / Altura del frente superior / Wysokość frontu górnego
FA	Frontaufschlag / front overlay / recouvrement / battuta frontale / recubrimiento del frente / Naożenie frontu	FHu	Fronthöhe unten / Lower front height / Hauteur de face inférieure / Altezza frontale inferiore / Altura del frente en la parte inferior / Wysokość frontu dolnego
FAu	Frontaufschlag unten / Lower front overlay / Recouvrement inférieur / Battuta frontale inferiore / Recubrimiento del frente en la parte inferior / Naożenie frontu dolnego	H	Höhe / height / hauteur / altezza / altura / Wysokość
FG	Frontgewicht / door weight / poids de face / peso del frontale / pesa de frentes / Waga frontu łącznie	KB	Korpusbreite / carcass width / largeur corps de meuble / larghezza corpo mobile / ancho cuerpo de mueble / Szerokość korpusu

Planung asymmetrisch / Planning asymmetrical / Planification asymétriques /  
 Progettazione asimmetrici / Planificación asimétricos / Planowanie asymetryczne

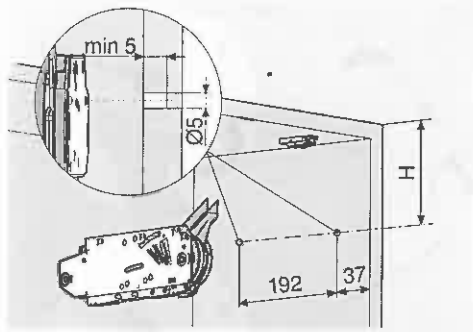

TKH: 480-549 mm    H: TKH x 0.3 - 28 mm  
 TKH: 550-1.040 mm    H: TKH x 0.3 - 57 mm

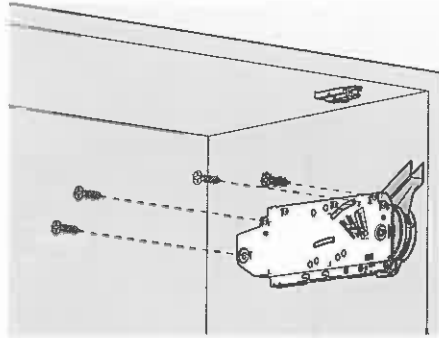

4 x Ø 4 x 35 mm

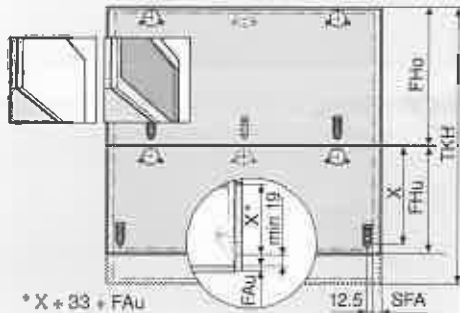
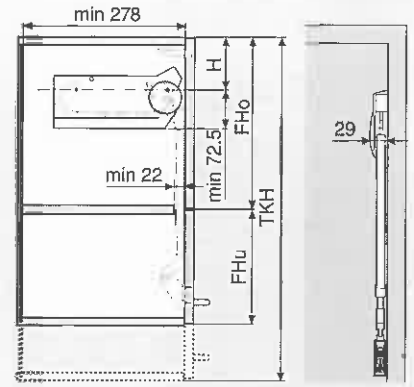

\* X + 33 + FAu

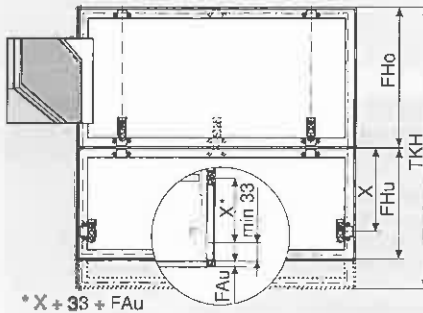

\* X + 33 + FAu



TKH	X	X
480-549 mm	FHo/2 + 68 mm	FHo/2 + 70 mm
550-1.040 mm	FHo/2 + 45 mm	FHo/2 + 47 mm

TKH	X
480-549 mm	FHo/2 + 64 mm
550-1.040 mm	FHo/2 + 31 mm

	KB	FG
3 x	1.200-1.799 mm	12-19 kg
4 x	1.800 mm	≥ 20 kg

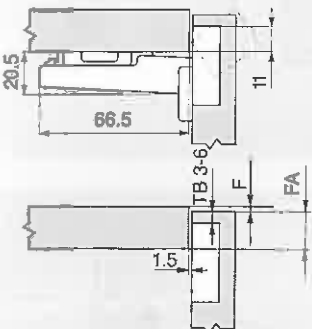

TB	FA
5	6 7 8 9 10 11 12 13 14 15 16 17
0	3 4 5 6
3	3 4 5 6
6	3 4 5 6
9	3 4 5 6
▲ MP	

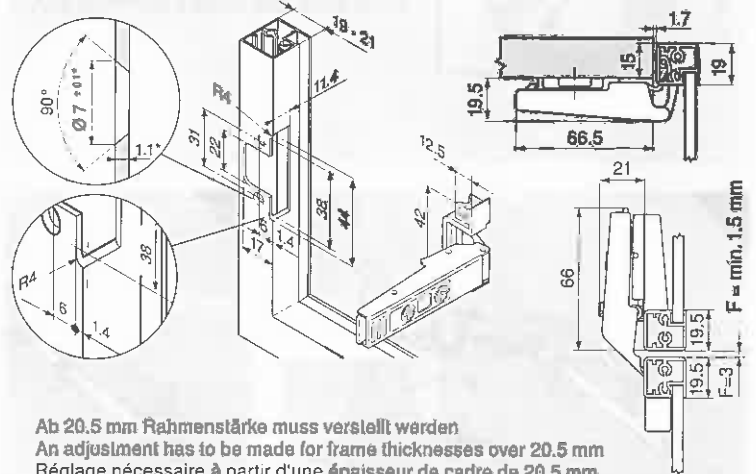

Ab 20.5 mm Rahmenstärke muss verstellt werden  
 An adjustment has to be made for frame thicknesses over 20.5 mm  
 Réglage nécessaire à partir d'une épaisseur de cadre de 20.5 mm  
 È necessaria una regolazione a partire da uno spessore del telaio di 20.5 mm  
 A partir de 20.5 mm resulta necesario ajustar el espesor del marco  
 Od grubości ramki 20.5 mm konieczne jest dopasowanie

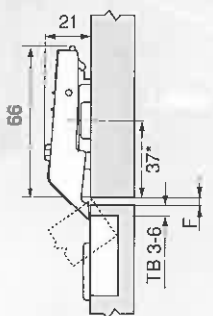

TB	F
0	3 4 5 6
3	6 5 4 3
6	
9	
▲ MP	

\* KMP (37/32)

\* Bei Veränderung der Materialstärke die Bearbeitungsmaße anpassen  
 When changing material thickness, adjust the assembly dimensions accordingly  
 En cas de modification de l'épaisseur du matériau, adapter les dimensions d'usage  
 In caso di modifica dello spessore del materiale adattare la quota di lavorazione  
 Adaptar las medidas de elaboración a los distintos espesores del material  
 Przy zmianie grubości materiału dopasować wymiary obróbki

KH	Korpshöhe / cabinet height / hauteur corps de meuble / altezza del corpo mobile / altura de cuerpo de mueble / Wysokość korpusu	SFA	Seillicher Frontaufschlag / side front overlay / recouvrement latéral / somonto laterale / recubrimiento lateral del frente / Boczne nałożenie frontu
KMP	Kreuzmontageplatte / cruciform mounting plates / embases en croix / piastrina di premontaggio a croce / bases en cruz / Prowadnik krzyżakowy	TB	Topfstand / drilling distance / distancia du bŏitler / distanza fondello / distancia de cazoleta / Odległość puszk
MP	Montageplatte / mounting plate / embase / piastrina di premontaggio / base / Prowadnik	TKH	Theoretische Korpshöhe / Theoretical cabinet height / Hauteur théorique de corps de meuble / Altezza teorica corpo mobile / Altura del cuerpo teórica / Teoretyczna wysokość korpusu

Montage / Assembly / Montage / Montaggio / Montaje / Montaż

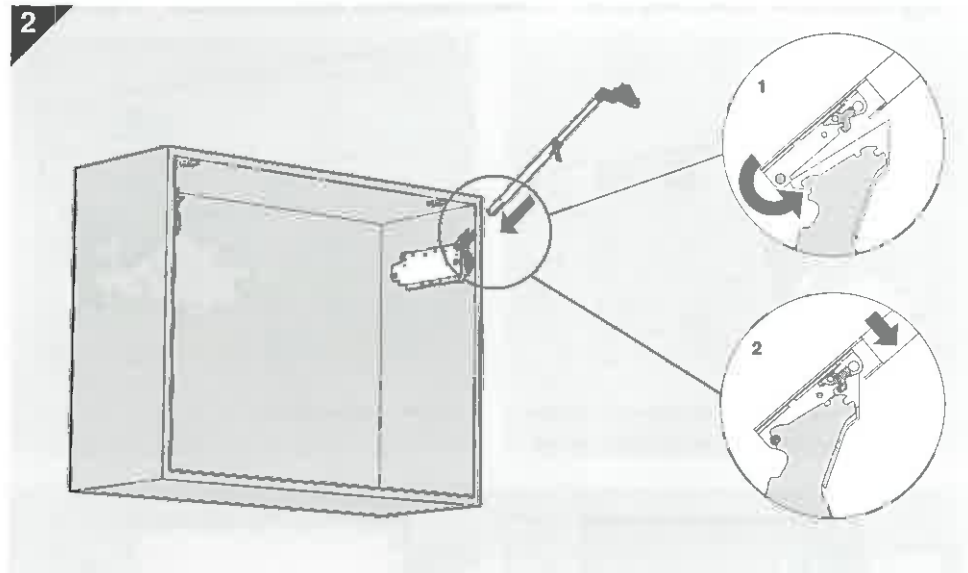
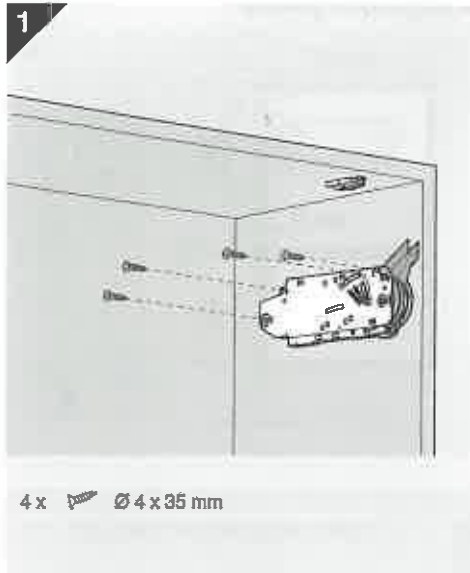

 **Warning / Warning / Attention / Attenzione / Advertencia / Ostrzeżenie / 警告**

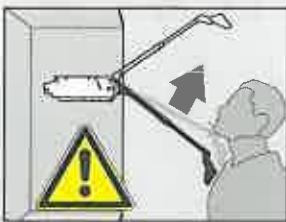

Verletzungsgefahr durch hochspringenden **Teleskophebel!**  
**Risk of injury by spring-loaded telescopic arm!**  
 Risque de blessure **en cas de relevage brusque** du bras télescopique !  
 Pericolo di **lesioni a causa del possibile scatto verso l'alto** della leva telescopica!  
 Peligro de **lesiones por salto de la palanca** telescópica.  
 Niebezpieczeństwo zranienia przez **gwałtownie unoszący się podnośnik** teleskopowy!  
 アームが跳ね上がってケガをする可能性があります。



**Teleskophebel nicht nach unten drücken, sondern entfernen.**  
**Do not push telescopic arm down without door attached but remove.**  
**Ne pas pousser le bras télescopique vers le bas, mais le retirer.**  
**Non spingere la leva telescopica verso il basso, altrimenti rimuoverlo.**  
**No apretar la palanca telescópica hacia abajo, si no retirarlo.**  
**Nie opuszczać podnośnika teleskopowego, lecz wyjąć.**  
 アームを外す時は下に押さないでください。

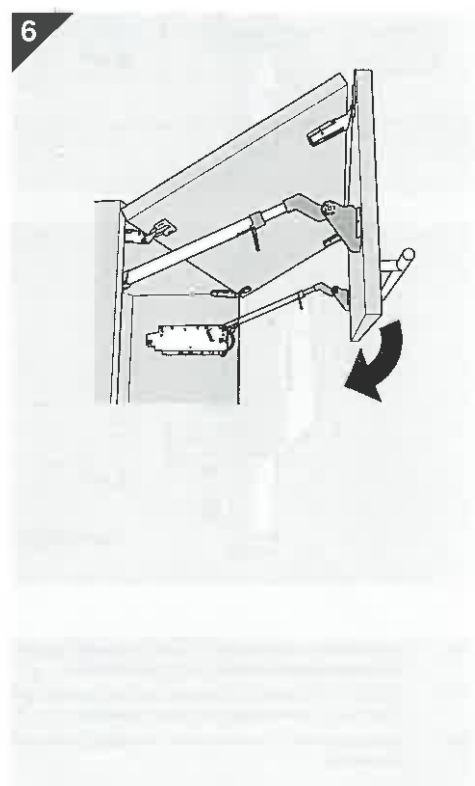
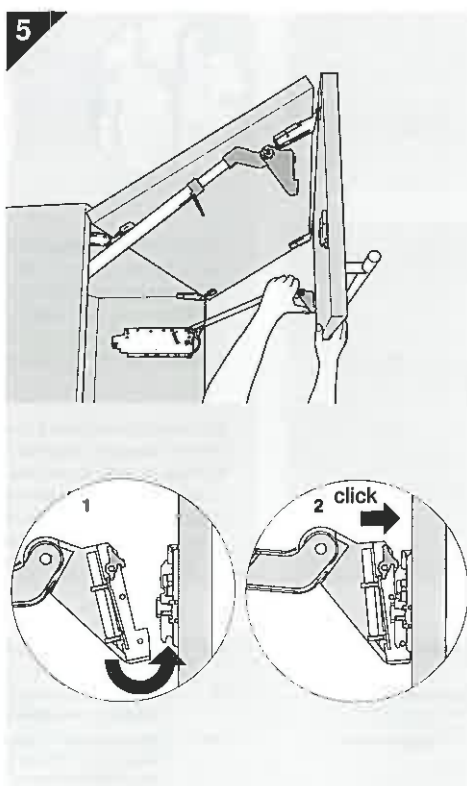
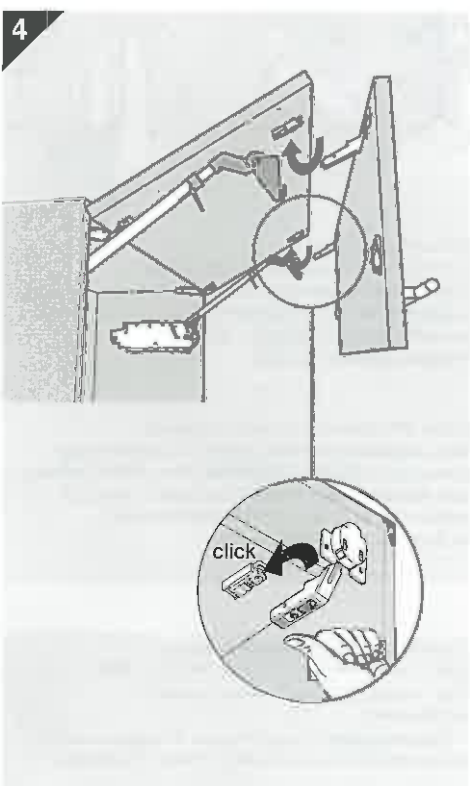
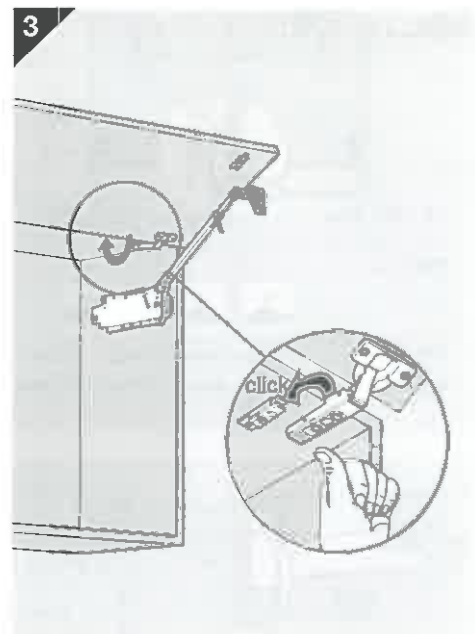

7

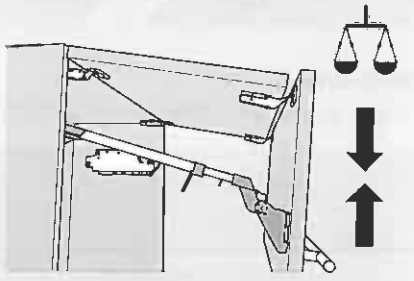
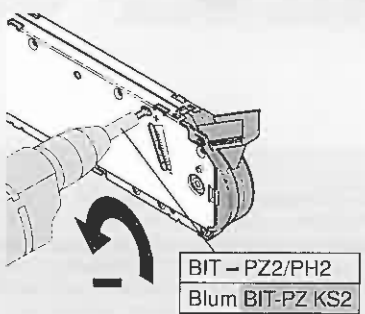
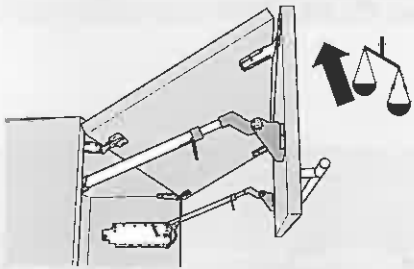
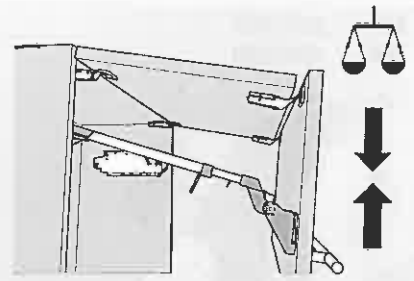
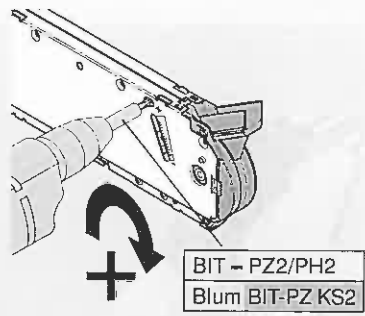
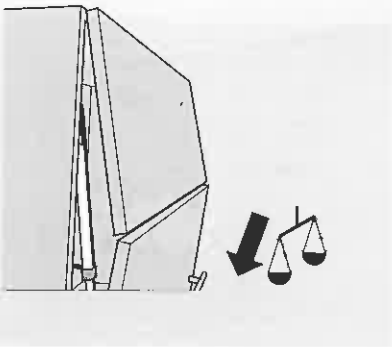

8

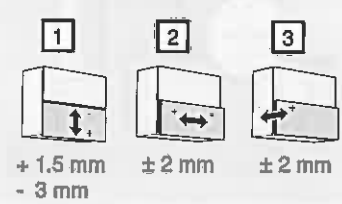
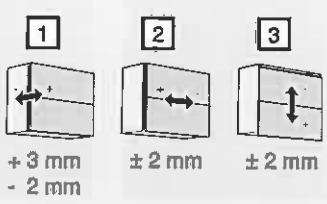
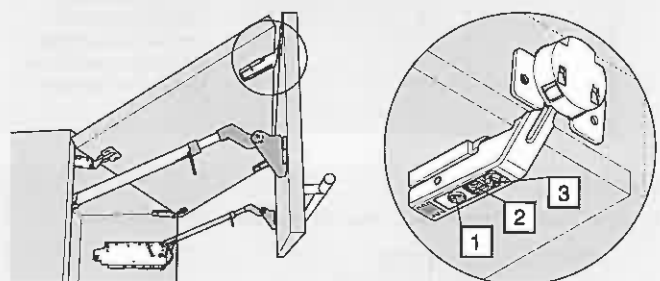
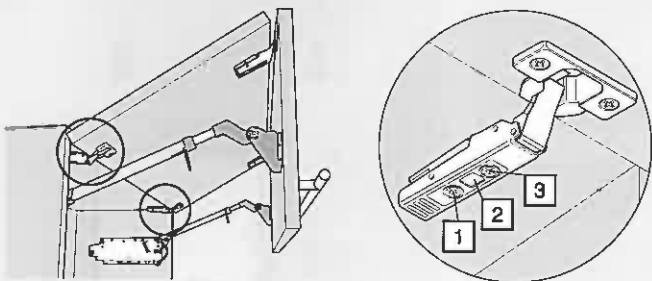

9

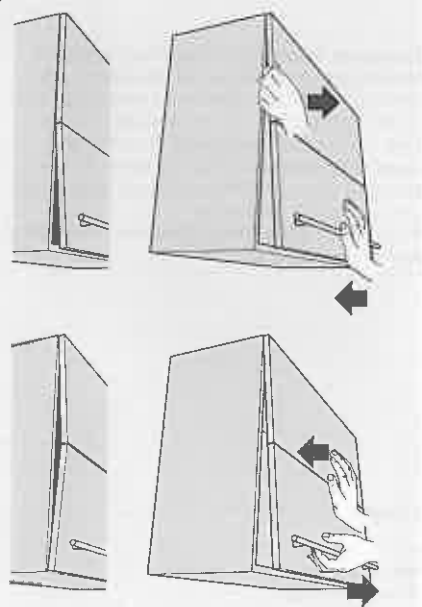

10

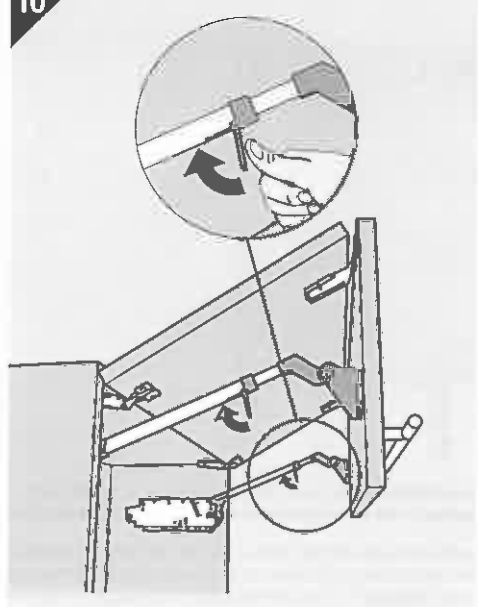

11

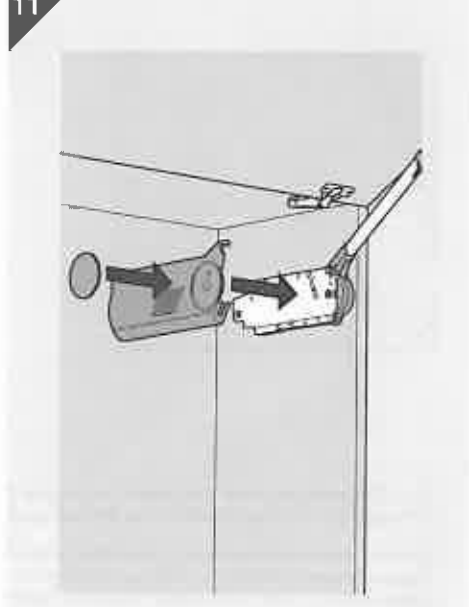

Öffnungswinkelbegrenzer / Opening angle stop / Limiteur d'ouverture / limitatore angolo di apertura /  
 Limitador de ángulo de apertura / Ogranicznik kąta otwarcia

83° 20F7011  
 104° 20F7051

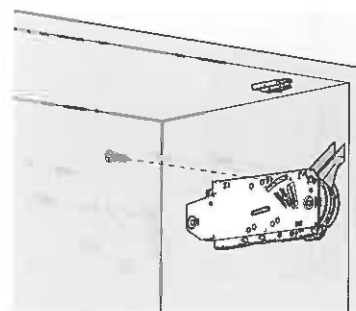
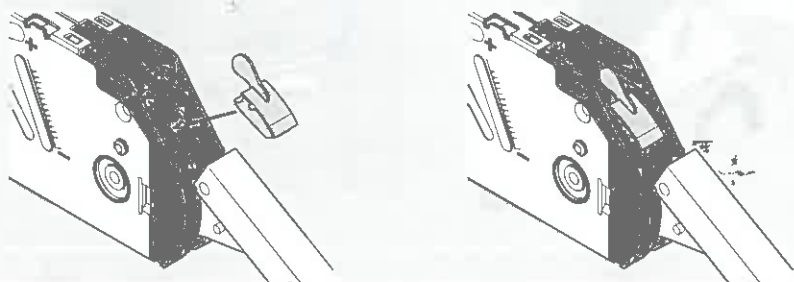

5 x Ø 4 x 35 mm

**SERVO-DRIVE**

für / for / pour / per / del / do AVENTOS HF

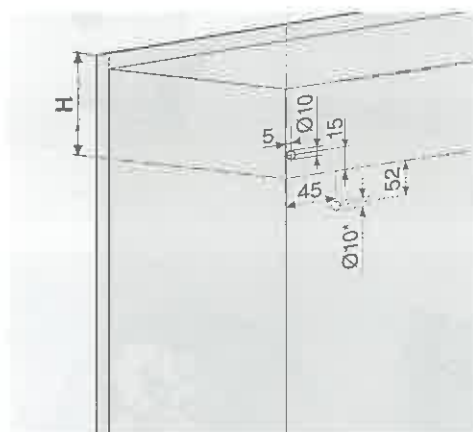

Verteilerkabel - nur auf linker Seite  
 Distribution cable - only on the left side  
 Câble de distribution - uniquement sur le côté gauche  
 Cavo di distribuzione - solo sul fianco sinistro  
 Cable de distribución - sólo en el lado izquierdo  
 Przewód zasilający - tylko po lewej stronie

\* Alternativbohrung  
 Alternative drilling  
 Perçage alternatif  
 Foratura alternativa  
 Taladrado alternativo  
 Otwór alternatywny

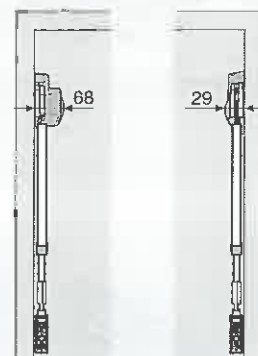

**SERVO-DRIVE-**

Schalter / Switch / Bouton radio / Interruttore / Interruptor / Włącznik

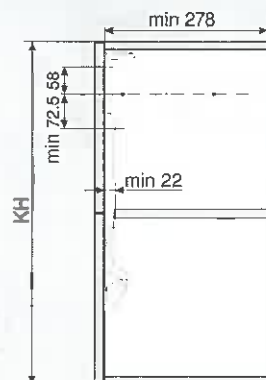
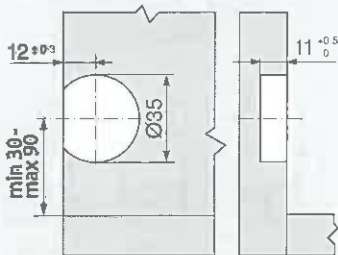

Blum-Distanzpuffer / Blum distance bumper / Butée Blum / Respingente Blum / Distanciador de amortiguación de Blum / Dystans Blum

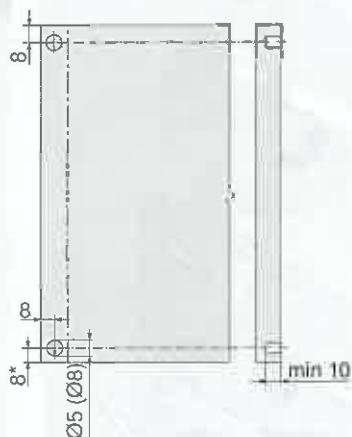
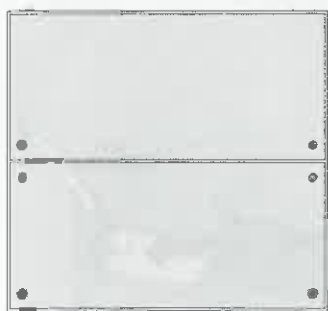

Alurahmen: Bohrung in Korpusseite vorsehen.  
 Aluminium frame: Drilling into the cabinet side.  
 Cadre en aluminium : prévoir un perçage pour la butée Blum dans le côté du corps de meuble.  
 Telaio in alluminio: prevedere la foratura per il respingente Blum nel fianco del corpo mobile.  
 Marco de aluminio: Tener en cuenta el taladrado para el costado del cuerpo.  
 Ramka aluminiowa: Przewidzieć otwór na dystans Blum w boku korpusu

Blum-Distanzpuffer nicht einleimen / Do not glue the Blum distance bumper / Ne pas encoller la butée Blum /  
 Non incollare i respingenti Blum / No introduzca el distanciador de amortiguación de Blum / Nie naklejać dystansu Blum

\* ab Korpuserkante bei nach unten überstehenden Fronten / from cabinet front edge for fronts that protrude below /  
 à partir du bord inférieur du corps sur les faces en saillie vers le bas / dal bordo inferiore del corpo mobile con frontali sporgenti verso il basso /  
 desde la arista inferior del cuerpo hasta los frentes situados debajo / od dolnej krawędzi korpusu przy wysuniętych w dół frontach



# Demontage / Removal / Démontage / Smontaggio / Desmontaje / Demontaz

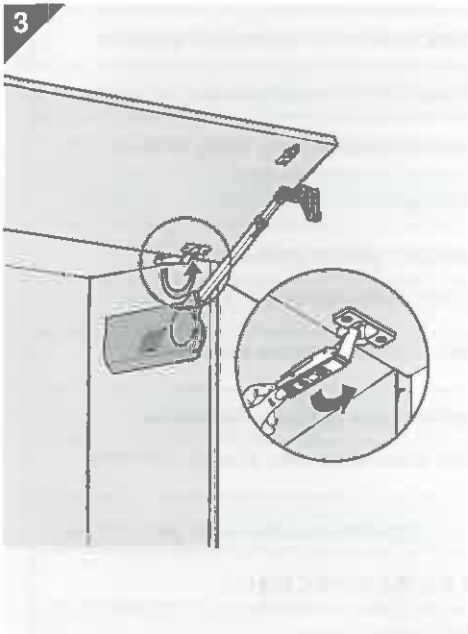
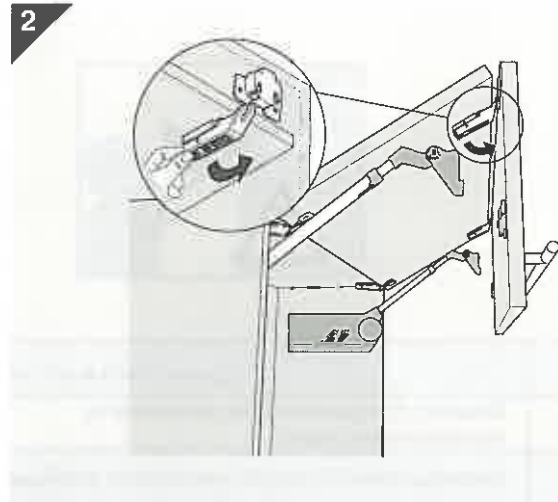
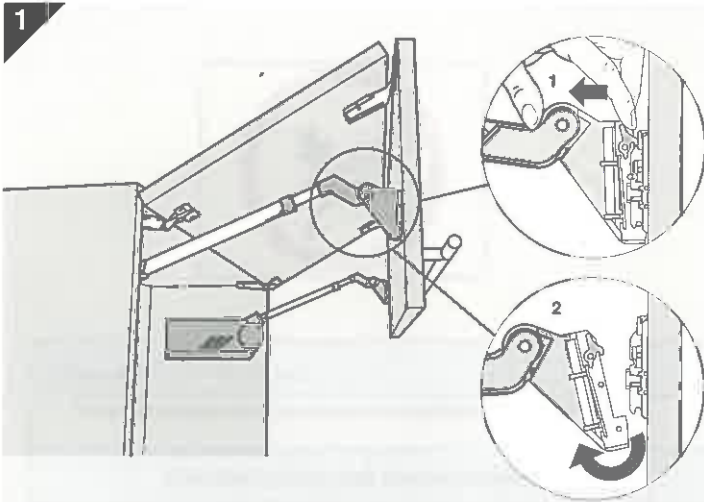

**Warning / Warnung / Warning / Attention / Attenzione / Advertencia / Ostrzeżenie / 警告**



Verletzungsgefahr durch hochspringenden Teleskophebel!  
 Risk of injury by spring-loaded telescopic arm!  
 Risque de blessure en cas de relevage brusque du bras télescopique!  
 Pericolo di lesioni a causa del possibile scatto verso l'alto della leva telescopica!  
 Peligro de lesiones por salto de la palanca telescópica.  
 Niebezpieczeństwo zranienia przez gwałtownie unoszący się podnośnik teleskopowy!  
 アームが跳ね上がってケガをする可能性があります。



Teleskophebel nicht nach unten drücken, sondern entfernen.  
 Do not push telescopic arm down without door attached but remove.  
 Ne pas pousser le bras télescopique vers le bas, mais le retirer.  
 Non spingere la leva telescopica verso il basso, altrimenti rimuoverlo.  
 No apretar la palanca telescópica hacia abajo, si no retirarlo.  
 Nie opuszczać podnośnika teleskopowego, lecz wyjąć.  
 アームを外す時は下に押さないでください。

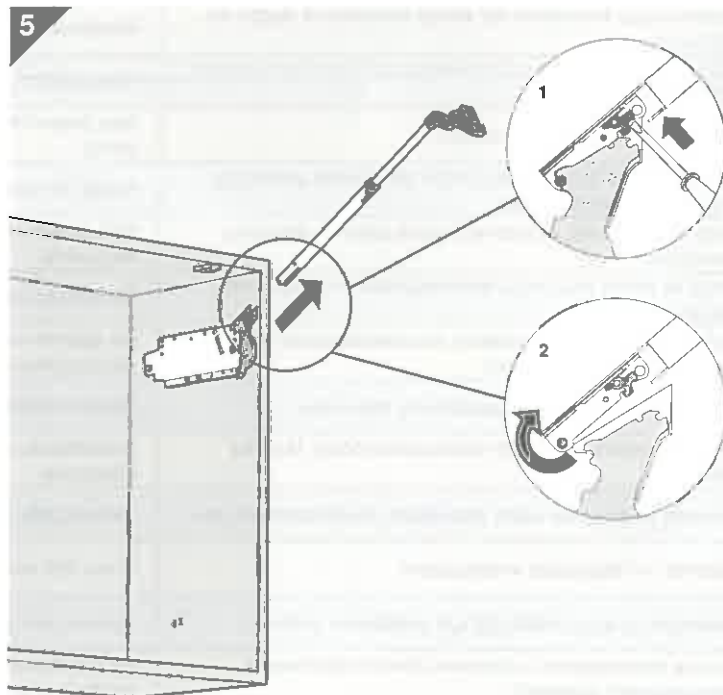
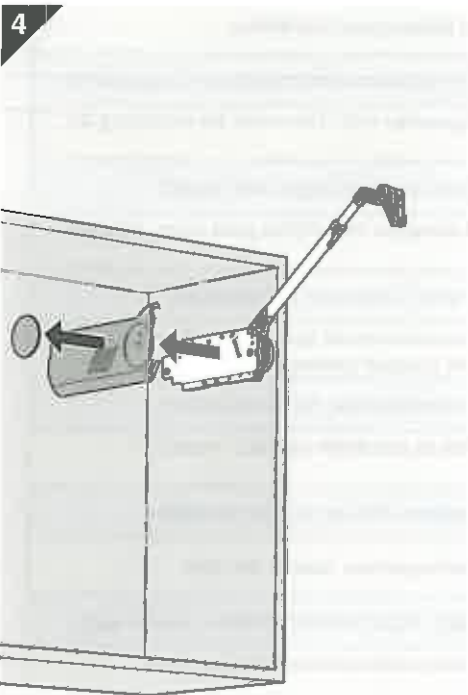



# WARNING 警告



AR	الذراع المتداخل يتدفع بقوة مما قد يحدث جرح	لا تقوم بتدفع الذراع المتداخل الى اسفل
BG	Опасност от нараняване при повдигане на телескопичната опора!	Телескопичната опора да не се натиска надолу, а да се отстранява.
CS	<b>Nebezpečí zranění z důvodu vystřelujícího teleskopu!</b>	<b>Netlačte teleskop směrem dolů, nýbrž ji odstraňte.</b>
DA	Risiko for at komme til skade ved opsvingning af teleskopstang!	Teleskopstang må ikke trykkes nedad, men fjernes.
DE	<b>Verletzungsfahr durch hochspringenden Teleskophebel</b>	<b>Teleskophebel nicht nach unten drücken, sondern entfernen.</b>
EL	Το τηλεσκοπικό μπράτσο μπορεί να πεταχτεί προς τα επάνω και να προκαλέσει τραυματισμό.	Μην σπρώχνετε προς τα κάτω το τηλεσκοπικό μπράτσο.
EN	<b>Risk of injury by spring-loaded telescopic arm!</b>	<b>Do not push telescopic arm down without door attached.</b>
ES	Peligro de lesiones por salto de la palanca telescópica.	<b>No apretar la palanca telescópica hacia abajo, si no retirarlo.</b>
ET	<b>Teleskoophoob võib viiskuda õles ja põhjustada trauma</b>	<b>Ära tõmba alla teleskoophooba.</b>
FI	Loukkaantumisvaara – varsi voi ponnahtaa ylöspäin!	Älä paina vartta alaspäin, vaan se pitää poistaa!
FR	Risque de blessure <b>en cas de relevage brusque du bras télescopique !</b>	Ne pas <b>pousser</b> le bras télescopique <b>vers</b> le bas, mais le retirer.
HR	Opasnost od ozljeda uslijed teleskopske poluge koja iskače!	Teleskopsku polugu ne pritišćite prema dolje, već ga uklonite.
HU	<b>Sérülésveszély a felugró teleszkópos emelőkar miatt!</b>	<b>A teleszkópos emelőkart nem szabad lefelé nyomni!</b>
IT	Pericolo di lesioni a causa del possibile scatto verso l'alto della leva telescopica!	Non spingere la leva telescopica verso il basso, altrimenti rimuoverlo.
IW	הזרוע הטלסקופית עלולה לקפוץ כלפי מעלה ולגרום לפציעה	אסור לדחוף את הזרוע הטלסקופית כלפי מטה
JA	アームが跳ね上がってケガをする可能性があります。	アームを外す時は下に押さないでください。
LT	<b>Teleskopinis svertas gali atšokti ir rimtai sužeisti.</b>	<b>Niekada nespauskite žemyn sverto.</b>
LV	Teleskopiskais kronšteins var strauji atvērties uz augšu un radīt traumu.	Nespiediet uz leju teleskopisko kronšteinu.
NL	Risico tot kwetsuren door omhoogspringende telescopische arm!	<b>Telescopische arm niet naar onder duwen maar verwijderen.</b>
NO	<b>Kraftig ljærpakke. Fare for skade !</b>	Ikke press teleskoparmen ned ! Demonter før montering av skrog.
PL	Niebezpieczeństwo zranienia <b>przez gwałtownie unoszący się podnośnik teleskopowy!</b>	<b>Nigdy nie opuszczaj teleskopowego, lecz wyciąć.</b>
PT	Perigo de ferimento, devido ao brusco salto da alavanca telescópica.	Não pressionar a alavanca telescópica para baixo, mas sim removê-la.
RO	Pericol de rănire prin brațul telescopic aflat sub tensiunea produsă de arcuri!	<b>Nu apăsați în jos brațul telescopic, ci îndepărtați-l.</b>
RU	Существует опасность травмы выскакивающим вверх телескопическим рычагом!	Не давите на телескопический рычаг вниз. В случае необходимости их следует снимать.
SK	<b>Riziko poranenia kvôli vyskakujúcemu teleskopu!</b>	<b>Netlačte teleskop smerom dole, ale ich odstráňte.</b>
SL	Nevarnost poškodbe zaradi teleskopske ročice, ki lahko odskoči!	Teleskopske ročice ne potiskajte navzdol, ampak ga odstranite.
SR	Opasnost od povreda usled iskakajuće teleskopske poluge!	Teleskopsku polugu ne pritiskali nadole, već skinuti.
SV	Skaderisk vid obelastad teleskoparm!	Tryck inte ned teleskoparmen, utan ta bort den.
TR	<b>Teleskopik kol sıçrayabileceği için yaralanma tehlikesi!</b>	<b>Teleskopik kol aşağı doğru bastırılmamalıdır, çıkarılmalıdır.</b>
UK	Загроза травмування з причини різкого підняття телескопічного важеля!	Не опускати до низу телескопічний важіль. Його необхідно зняти.
ZH	<b>伸缩臂上弹会伤害到人！</b>	<b>伸缩臂请勿下压，请务必取下。</b>

# SERVICEKARTE

VH

Liebe Kundin, lieber Kunde,

obwohl wir unsere Möbel vor der Auslieferung einer eingehenden Endkontrolle unterziehen, kann es vorkommen, dass einmal ein Zubehörteil fehlt oder während des Transports beschädigt wird. Senden sie den Artikel bitte nicht zurück, sondern fordern sie einfach Ersatz für das Einzelteil bei unserer Kundenhotline an. Die Telefonnummern finden sie auf den Serviceseiten im Katalog.

Bitte benennen sie die Teile wie sie auf ihrer Aufbauanleitung angegeben sind. Fügen sie auch **Artikelnummer, Modellnamen und Farbnummer** bei. **Siehe Beispiel.**

Wir werden ihre Anforderung sofort bearbeiten und ihnen das Ersatzteil umgehend zusenden.

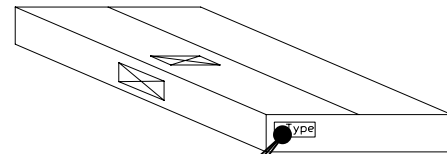
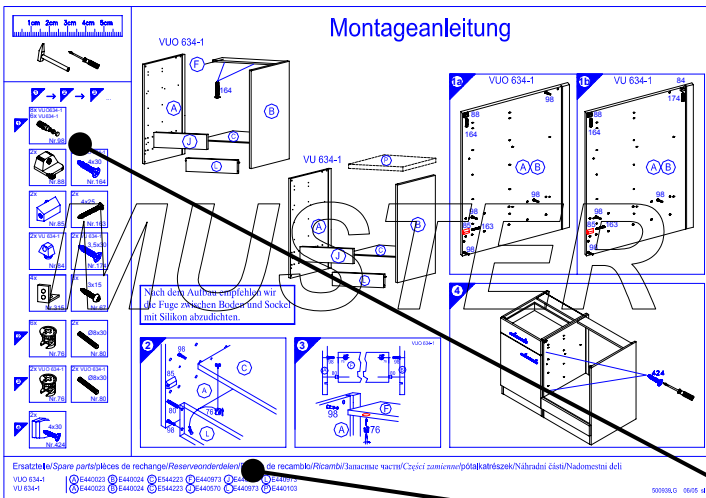

Muster - Bestellung		
Artikelnummer	123 456	
Modellname	Unterschrank VU634	
Farbe	TA 01	
Benötigte Ersatzteile:		
Bezeichnung	Nr.	Anzahl
Beschlagteil	98	2
Teil B	E 440 023	1

Bitte entnehmen sie die notwendige Ersatzteilnummer der Aufbauanleitung die zum Möbel gehört!

Kundendaten	
Kundennummer	
Name	
Vorname	
Strasse	
Haus-Nr.	
PLZ	
Ort	
Rechnungsdatum	
Tel. für Rückfragen	
Notizen:	

Ersatzteilbestellung		
Artikelnummer		
Modellname		
Farbe		
Benötigte Ersatzteile:		
Bezeichnung	Nr.	Anzahl
Grund der Ersatzteilanforderung:		