

# MONTAGEANLEITUNGEN/ASSEMBLY ISTRUCTIONS

Artikelnummer: WF324844  
WF324845  
WF324846

## Hausbett 200x90cm

Installation sanleitung

Installation Instruction

Instruction d'installation

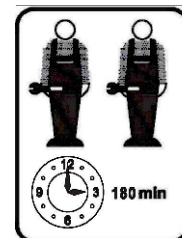
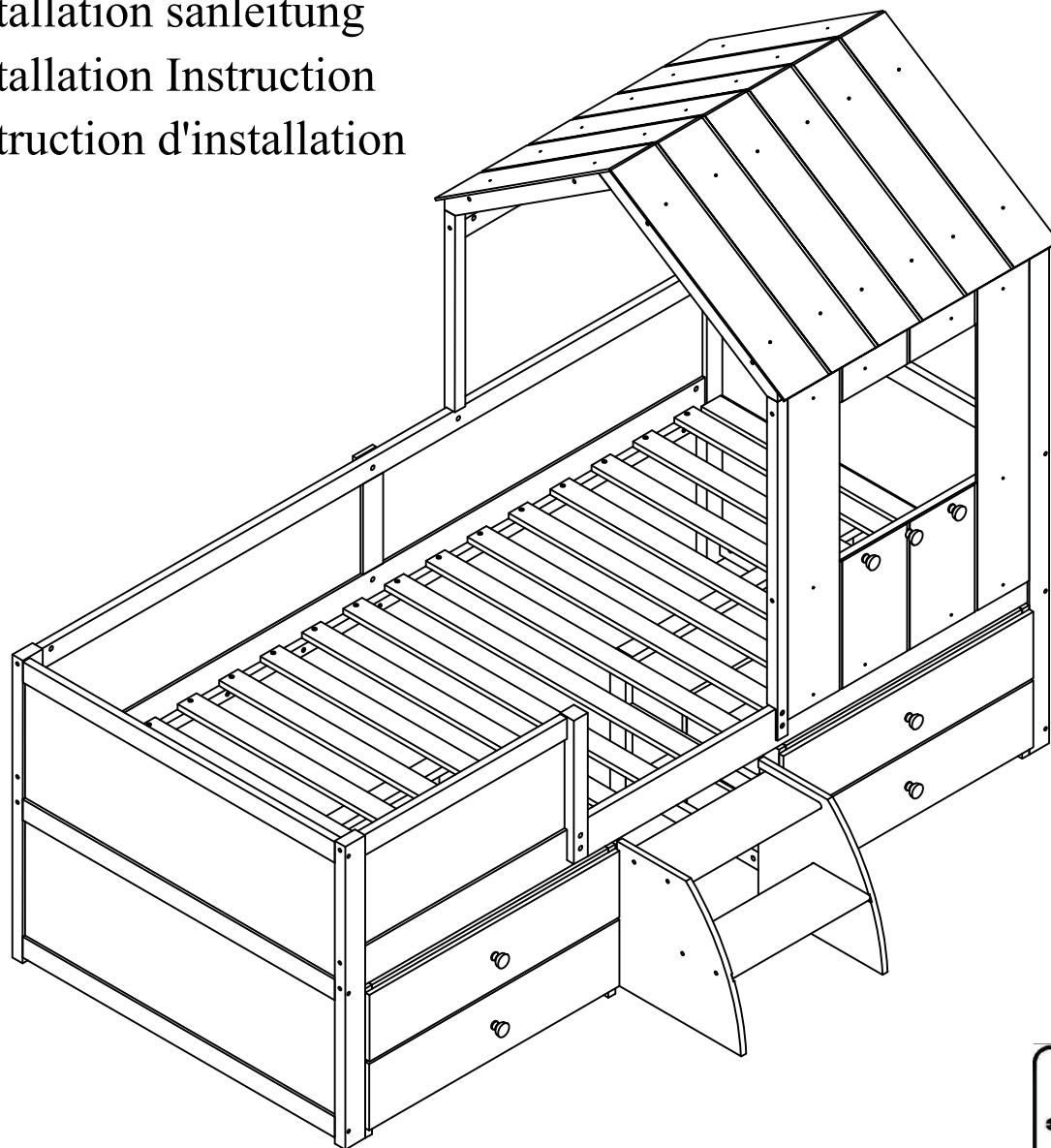

DE: Unser Produkt wird Ihnen in 3 Paketen geliefert. Die Lieferzeiten dieser 3 Pakete können abweichen, bitte haben Sie etwas Geduld und vielen Dank für Ihr Verständnis.

UK: Our product will be delivered to you in 3 packages. The delivery times of these 3 packages may differ please be patient and thank you for your understanding.

FR: Notre produit vous sera livré en 3 colis. Les délais de livraison de ces 3 colis peuvent différer, soyez patient et merci pour votre compréhension.

## INSTRUCTIONS

### IMPORTANT-READ CAREFULLY-RETAIN FOR FUTURE REFERENCE

- a) **WARNING**-High beds and the upper bed of bunk beds are not suitable for children under six years due to the risk of injury from falls;
- b) **WARNING**-Bunk beds and high beds can present a serious risk of injury from strangulation if not used correctly. Never attach or hang items to any part of the bunk bed that are not designed to be used with the bed, for example, but not limited to ropes, strings, cords, hooks, belts and bags.
- c) **WARNING**-Children can become trapped between the bed and the wall, a roof pitch, the ceiling adjoining pieces of furniture (e.g. cupboards) and the like. To avoid risk of serious injury the distance between the top safety barrier and the adjoining structure shall not exceed 75 mm or shall be more than 230 mm.
- d) **WARNING**-Do not use the bunk bed/high bed if any structural part is broken or missing; Replacement parts are between requested from the manufacturer or the store.
- e) it is imperative to always follow the installation instructions and manufacturer's use.
- f) The recommended size of the mattress to be used with the bed is **90x200**cm, maximum thickness mattress: **15cm**.
- g) It is necessary to ventilate the room in order to maintain a low level moisture and prevent mold growth in the bed and its periphery.
- h) Joining devices should always be tightened properly and regularly verified. Tighten if necessary.

## ANLEITUNG

### WICHTIG-SORGFÄLTIG DURCHLESEN-FÜR ZUKÜNFTIGE REFERENZ BEWAHREN

- a) **WARNUNG**-Das Oberbett von Etagenbett ist wegen der Verletzungsgefahr durch Stürze nicht für Kinder unter sechs Jahren geeignet.
- b) **WARNUNG**-Etagenbetten und Hochbetten können ein ernstes Verletzungsrisiko darstellen, wenn sie nicht ordnungsgemäß verwendet werden. Befestigen oder hängen Sie niemals etwas an einem Teil des Etagenbettes, das nicht für das Bett bestimmt ist, wie z. B. Seile, Haken, Gurte und Taschen.
- c) **WARNUNG**-Kinder können zwischen Bett und Wand eingeklemmt werden. Um die Gefahr schwerer Verletzungen zu vermeiden, darf der Abstand zwischen der oberen Sicherheitsbarriere und der angrenzenden Konstruktion 75 mm nicht überschreiten oder mehr als 230 mm betragen.
- d) **WARNUNG**-Verwenden Sie das Etagenbett nicht, wenn ein Bauteil beschädigt ist oder fehlt. Ersatzteile werden zwischendurch beim Hersteller oder beim Händler angefordert.
- e) Befolgen Sie unbedingt die Anweisung des Herstellers.
- f) Die empfohlene Größe der Matratze für das Bett beträgt **90x200cm**, maximale Dicke der Matratze: **15cm**.
- g) Es ist notwendig, den Raum zu lüften, um ein niedriges Feuchtigkeitsniveau aufrechtzuerhalten und das Wachstum von Schimmel im Bett und an dessen Peripherie zu verhindern.
- h) Verbindungselemente sollten immer richtig angezogen und regelmäßig überprüft werden. Bei Bedarf festziehen.

## English

### IMPORTANT ! KEEP FOR FUTURE REFERENCE : READ CAREFULLY

- To be assembled by an adult. Assembly must be checked by an adult before use
- WARNING ! Keep all screws, small parts and plastic bags out of the reach of children
- Properly identify all parts before assembling
- Never use your item if any of its parts are broken or missing
- Should any problems arise, please contact our After Sales Service
- Manufacturer's instructions shall be followed at all times
- Care: Clean with a soft, dry cloth. In case of larger stains, carefully rub with a slightly damp, non-abrasive sponge
- Avoid the risk of fire by not placing furniture near sources of ignition or hot items
- Do not jump on the bed

## Deutsch

### WICHTIG ! ZUM SPÄTEREN NACHSCHLAGEN AUFBEWAHREN: SORGFÄLTIG LESEN

- Muss von einem Erwachsenen zusammengebaut werden. Der Zusammenbau muss vor dem Gebrauch von einem Erwachsenen überprüft werden
- WARNUNG! Bewahren Sie alle Schrauben, Kleinteile und Plastikbeutel außerhalb der Reichweite von Kindern auf
- Kennzeichnen Sie vor dem Zusammenbau alle Teile richtig
- Benutzen Sie Ihren Artikel niemals, wenn Teile gebrochen sind oder fehlen
- Sollten Probleme auftreten, wenden Sie sich bitte an unseren Kundendienst
- Die Anweisungen des Herstellers sind stets zu befolgen
- Pflege: Mit einem weichen, trockenen Tuch reinigen. Bei größeren Flecken vorsichtig mit einem leicht feuchten, nicht scheuernden Schwamm abreiben. nicht scheuernden Schwamm
- Vermeiden Sie die Gefahr eines Brandes, indem Sie die Möbel nicht in der Nähe von Zündquellen oder heißen Gegenständen aufstellen
- Nicht auf das Bett springen

## Français

### IMPORTANT ! CONSERVER POUR RÉFÉRENCE ULTÉRIEURE : LIRE ATTENTIVEMENT

- Le montage doit être effectué par un adulte. Le montage doit être vérifié par un adulte avant Utilisation
- ATTENTION ! Tenir les vis, les petites pièces et les sachets en plastique hors de portée des enfants
- Identifiez correctement toutes les pièces avant de les assembler
- N'utilisez jamais votre article si l'une de ses pièces est cassée ou manquante
- En cas de problème, veuillez contacter notre service après-vente
- Les instructions du fabricant doivent être respectées à tout moment
- Entretien : nettoyer avec un chiffon doux et sec. En cas de taches plus importantes, frotter soigneusement avec une éponge non abrasive légèrement humide. légèrement humide et non Abrasive
- Évitez les risques d'incendie en ne plaçant pas les meubles à proximité de sources d'inflammation ou d'objets chauds
- Ne pas sauter sur le lit

## Italiano

### IMPORTANTE! CONSERVARE PER RIFERIMENTO FUTURO: LEGGERE ATTENTAMENTE

- Deve essere assemblato da un adulto. L'assemblaggio deve essere controllato da un adulto prima dell'uso
- **ATTENZIONE!** Tenere tutte le viti, le piccole parti e i sacchetti di plastica fuori dalla portata dei bambini
- Identificare correttamente tutte le parti prima dell'assemblaggio
- Non utilizzare mai l'articolo se alcune parti sono rotte o mancanti
- In caso di problemi, si prega di contattare il nostro Servizio Post Vendita
- Le istruzioni del produttore devono essere sempre seguite
- Cura: Pulire con un panno morbido e asciutto. In caso di macchie più estese, strofinare accuratamente con una spugna leggermente umida e non abrasiva
- Evitare il rischio di incendio, non collocando i mobili vicino a fonti di accensione o a oggetti caldi
- Non saltare sul letto

## Español





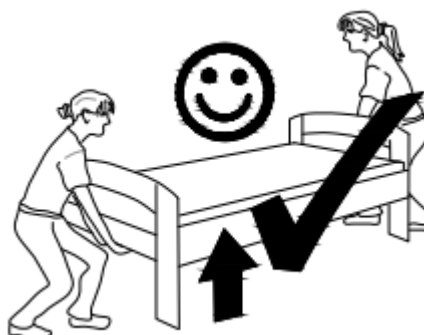
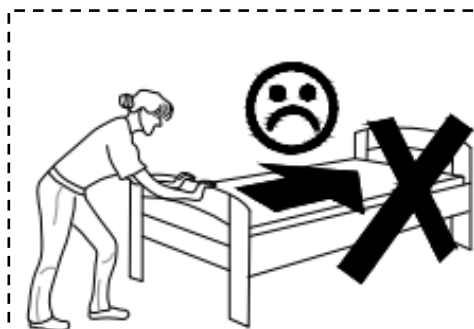

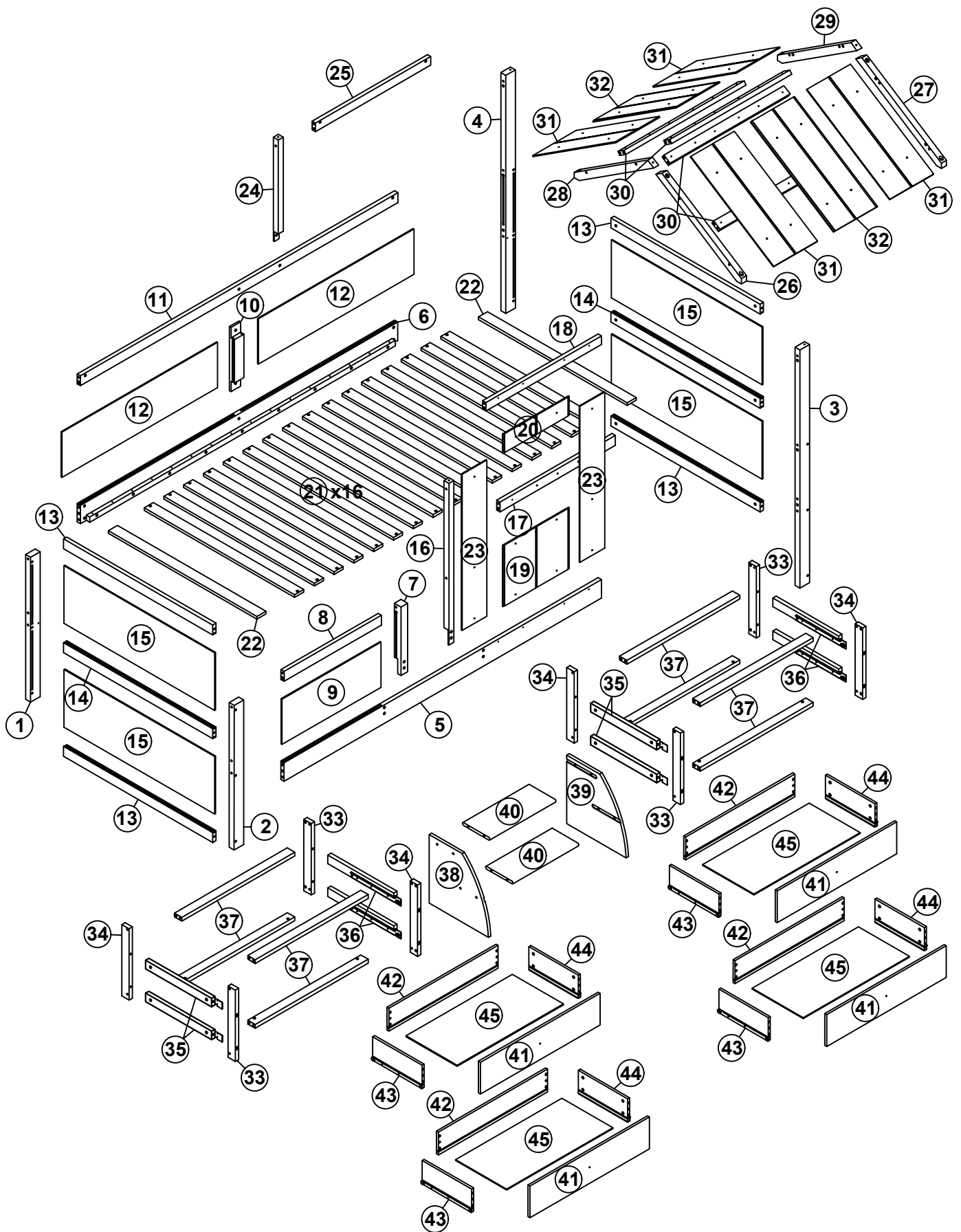

### ¡ IMPORTANTE ! CONSERVELO PARA FUTURAS CONSULTAS: LEA ATENTAMENTE

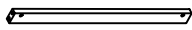
- Debe ser montado por un adulto. El montaje debe ser comprobado por un adulto antes del uso
- ADVERTENCIA Mantenga todos los tornillos, piezas pequeñas y bolsas de plástico fuera del alcance de los niños.
- Identifique correctamente todas las piezas antes de montarlas
  - Nunca utilice su artículo si alguna de sus piezas está rota o falta
  - Si surge algún problema, póngase en contacto con nuestro Servicio Postventa
  - Las instrucciones del fabricante deben seguirse en todo momento
  - Cuidado: Limpiar con un paño suave y seco. En caso de manchas más grandes, frote cuidadosamente con una esponja no abrasiva ligeramente humedecida.
  - Evite el riesgo de incendio no colocando los muebles cerca de fuentes de ignición u objetos calientes.
  - No saltar sobre la cama.

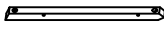
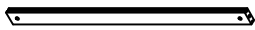
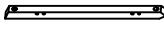
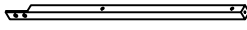
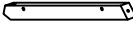

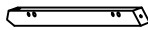
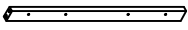



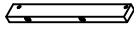
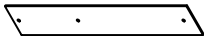
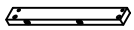
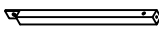
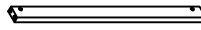



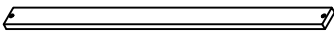
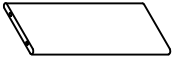
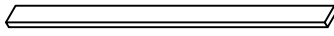
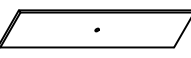
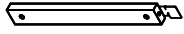

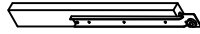

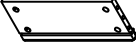

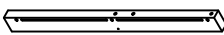
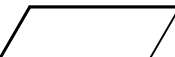
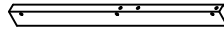

## WF324844 (Hardware-in dieser SKU)

<b>8</b>	 Stange am Vorderbein Balustradenrahmen	<b>1pc</b>	<b>25</b>	 Rechtes vorderes Geländer	<b>1pc</b>
<b>13</b>	 Kopfteilrahmen	<b>4pcs</b>	<b>26</b>	 Dach - vordere Stütze	<b>1pc</b>
<b>14</b>	 Kopfteilrahmen	<b>2pcs</b>	<b>27</b>	 Dach - vordere Stütze	<b>1pc</b>
<b>16</b>	 Untere vordere Stütze des Daches	<b>1pc</b>	<b>28</b>	 Dach - hintere Stütze	<b>1pc</b>
<b>17</b>	 Rechtes vorderes Geländer	<b>1pc</b>	<b>29</b>	 Dach - hintere Stütze	<b>1pc</b>
<b>18</b>	 Rechtes vorderes Geländer	<b>1pc</b>	<b>30</b>	 Träger für Dachpaneele	<b>4pcs</b>
<b>19</b>	 Oberes Fensterpaneel	<b>1pc</b>	<b>45</b>	 Untere Schubladenplatte	<b>4pcs</b>
<b>20</b>	 Oberes Fensterpaneel	<b>1pc</b>	<b>33</b>	 Linkes Vorderbein & Rechtes Hinterbein	<b>4pcs</b>
<b>23</b>	 Oberes Fensterpaneel	<b>2pcs</b>	<b>34</b>	 Linkes Hinterbein & Rechtes Vorderbein	<b>4pcs</b>
<b>24</b>	 Untere hinterer Stütze des Daches	<b>1pc</b>	<b>37</b>	 Seitliche Schubladenrahmen	<b>8pcs</b>

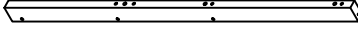
## WF324845

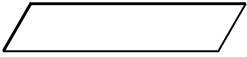
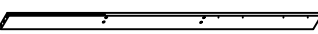
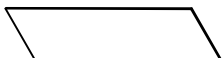
<b>21</b>	Latten 	<b>16pcs</b>	<b>40</b>	Bodenplatte der Aufbewahrungsleiter 	<b>2pcs</b>
<b>22</b>	Latten 	<b>2pcs</b>	<b>41</b>	Schubladenfronten 	<b>4pcs</b>
<b>35</b>	Unterstützung der seitlichen Schubladen 	<b>4pcs</b>	<b>42</b>	Schubladenrückwände 	<b>4pcs</b>
<b>36</b>	Unterstützung der seitlichen Schubladen 	<b>4pcs</b>	<b>43</b>	Schublade links 	<b>4pcs</b>
<b>38</b>	Aufbewahrungsleiter Seitenwand 	<b>1pc</b>	<b>44</b>	Schublade rechts 	<b>4pcs</b>
<b>39</b>	Aufbewahrungsleiter Seitenwand 	<b>1pc</b>			

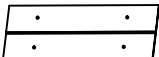
## WF324846

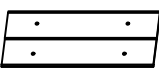
<b>1</b>	Linkes Hinterbein 	<b>1pc</b>	<b>9</b>	Kopfteilrahmen 	<b>1pc</b>
<b>2</b>	Linkes Vorderbein 	<b>1pc</b>	<b>10</b>	Stützen der Hinterbein Leitplanken 	<b>1pc</b>
<b>3</b>	Rechtes Vorderbein 	<b>1pc</b>	<b>11</b>	Stange am Hinterbein Balustradenrahmen 	<b>1pc</b>
<b>4</b>	Rechtes Hinterbein 	<b>1pc</b>	<b>12</b>	Kopfteilplatte 	<b>2pcs</b>
<b>5</b>	Vorderer Seitenholm 	<b>1pc</b>	<b>15</b>	Kopfteilplatte 	<b>4pcs</b>
<b>6</b>	Hinterer Seitenholm 	<b>1pc</b>	<b>31</b>	Dachplatten 	<b>4pcs</b>
<b>7</b>	Stützen der Vordere Leitplanken 	<b>1pc</b>	<b>32</b>	Dachplatten 	<b>2pcs</b>



# ASSEMBLY INSTRUCTIONS

**DE:** Vor dem Einbau die Schrauben in die Löcher stecken und festziehen, aber nicht bis 100%, 70% bis 80% anziehen reicht aus. Schließlich, nachdem alle Schrauben installiert sind, ziehen Sie alle Schrauben auf 100%. Wenn Sie auf diese Probleme stoßen, wie z. B. Fehlausrichtung der Löcher oder Unfähigkeit, bestimmte Teile zu installieren, überprüfen Sie bitte, ob die Schrauben korrekt verwendet werden und passen Sie die Dichtigkeit der Schrauben an.

**UK:** Before installation, insert the screws into the holes and tighten them, but do not tighten them to 100%, 70% to 80% is sufficient. Finally, after all screws are installed, tighten all screws to 100%. If you encounter these issues, such as if the holes cannot be aligned or some parts cannot be installed, please check if the screws are used correctly and adjust the tightness of the screws.





**FR:** Insérer la vis dans le trou avant la fin de l'assemblage, serrer la vis, mais ne pas serrer à 100%, 70% ~ 80% est correct. Enfin, une fois que toutes les vis sont bien serrées, toutes les vis sont serrées à 100%. Si vous rencontrez ces problèmes, par exemple si les trous ne sont pas alignés ou si certaines pièces ne peuvent pas être montées, vérifiez que les vis sont utilisées correctement et Ajustez leur serrage.

<b>D</b>	<b>Ø4x35</b>		<b>3PCS</b>	<b>E</b>	<b>Ø4x25</b>		<b>4PCS</b>
----------	--------------	---	-------------	----------	--------------	---	-------------

**DE:** Bitte beachten Sie, dass die Formen der Schrauben D und E ähnlich sind. Bitte installieren Sie entsprechend der Anleitung und unterscheiden Sie sie!

**UK:** Please note that the shapes of screws D and E are similar. Please install according to the instructions and distinguish them!



**FR:** Notez que les vis D et E ont des formes similaires. Veuillez les installer en suivant les instructions pour les séparer!

<b>F</b>	<b>1/4x100</b>		<b>14PCS</b>	<b>H</b>	<b>1/4x75</b>		<b>23PCS</b>
<b>G</b>	<b>1/4x90</b>		<b>17PCS</b>	<b>I</b>	<b>1/4x60</b>		<b>24PCS</b>

**DE:** Bitte beachten Sie, dass die Formen der Schrauben F und G und H und I ähnlich sind. Bitte installieren Sie entsprechend der Anleitung und unterscheiden Sie sie!

**UK:** Please note that the shapes of screws F and G and H and I are similar. Please install according to the instructions and distinguish them!



**FR:** Notez que les vis F et G et H et I ont des formes similaires. Veuillez les installer en suivant les instructions pour les séparer!

<b>J</b>	<b>1/4x35</b>		<b>2PCS</b>	<b>K</b>	<b>1/4x25</b>		<b>5PCS</b>
----------	---------------	---	-------------	----------	---------------	---	-------------













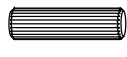



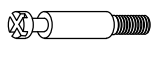

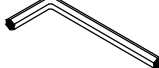

**DE:** Bitte beachten Sie, dass die Formen der Schrauben J und K ähnlich sind. Bitte installieren Sie entsprechend der Anleitung und unterscheiden Sie sie!

**UK:** Please note that the shapes of screws J and K are similar. Please install according to the instructions and distinguish them!

**FR:** Notez que les vis J et K ont des formes similaires. Veuillez les installer en suivant les instructions pour les séparer!

<b>L</b>	<b>6.5x80</b>		<b>2PCS</b>	<b>M</b>	<b>6.5x60</b>		<b>4PCS</b>
<p><b>DE:</b> Bitte beachten Sie, dass die Formen der Schrauben L und M ähnlich sind. Bitte installieren Sie entsprechend der Anleitung und unterscheiden Sie sie!</p> <p><b>UK:</b> Please note that the shapes of screws L and M are similar. Please install according to the instructions and distinguish them!</p> <p><b>FR:</b> Notez que les vis L et M ont des formes similaires. Veuillez les installer en suivant les instructions pour les séparer!</p>							

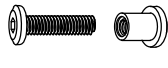
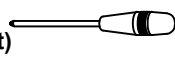
### List der Hardware (WF324844)

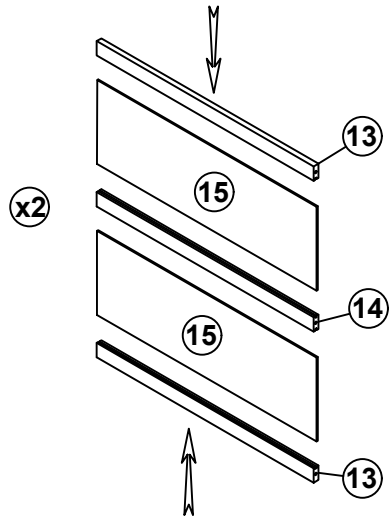

<b>A</b>	<b>Ø4x30</b>		<b>32PCS</b>	<b>M</b>	<b>6.5x60</b>		<b>4PCS</b>
<b>B</b>	<b>Ø4x15</b>		<b>8PCS</b>	<b>N</b>	<b>Ø10x40</b>		<b>38PCS</b>
<b>C</b>	<b>Ø4x20</b>		<b>34PCS</b>	<b>O</b>	<b>Ø8x30</b>		<b>16PCS</b>
<b>D</b>	<b>Ø4x35</b>		<b>3PCS</b>	<b>P</b>	<b>Ø6.5x35</b>		<b>32PCS</b>
<b>E</b>	<b>Ø4x25</b>		<b>4PCS</b>	<b>Q</b>	<b>Ø12x10</b>		<b>32PCS</b>
<b>F</b>	<b>1/4x100</b>		<b>14PCS</b>	<b>R</b>	<b>15x15x2</b>		<b>4PCS</b>
<b>G</b>	<b>1/4x90</b>		<b>17PCS</b>	<b>S</b>	<b>4x58</b>		<b>1PC</b>
<b>H</b>	<b>1/4x75</b>		<b>23PCS</b>	<b>T</b>	<b>Ø28x27 (N)</b>		<b>3PCS</b>
<b>I</b>	<b>1/4x60</b>		<b>24PCS</b>	<b>U</b>	<b>Ø28x27 (W)</b>		<b>4PCS</b>
<b>J</b>	<b>1/4x35</b>		<b>2PCS</b>	<b>V</b>	<b>Ø3.5x12 (W)</b>		<b>8PCS</b>
<b>K</b>	<b>1/4x25</b>		<b>5PCS</b>	<b>Benötigte Werkzeuge (nicht von uns gestellt)</b>			
<b>L</b>	<b>6.5x80</b>		<b>2PCS</b>				

1

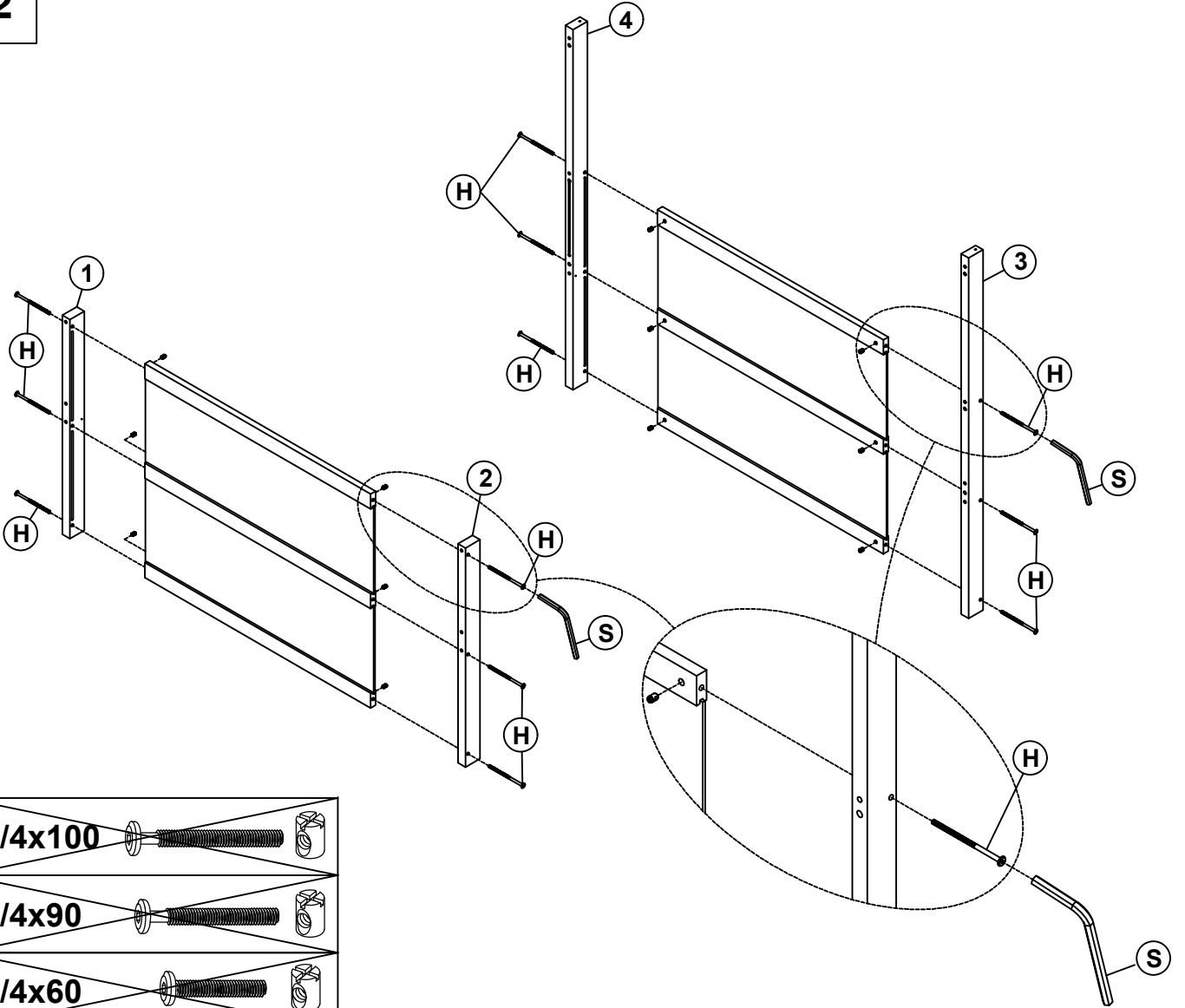

2





- 1/4x100 
- 1/4x90 
- 1/4x60 

<b>H</b>	<b>1/4x75</b>		<b>12PCS</b>	<b>S</b>	<b>4x58</b>		<b>1PC</b>
----------	---------------	---	--------------	----------	-------------	---	------------

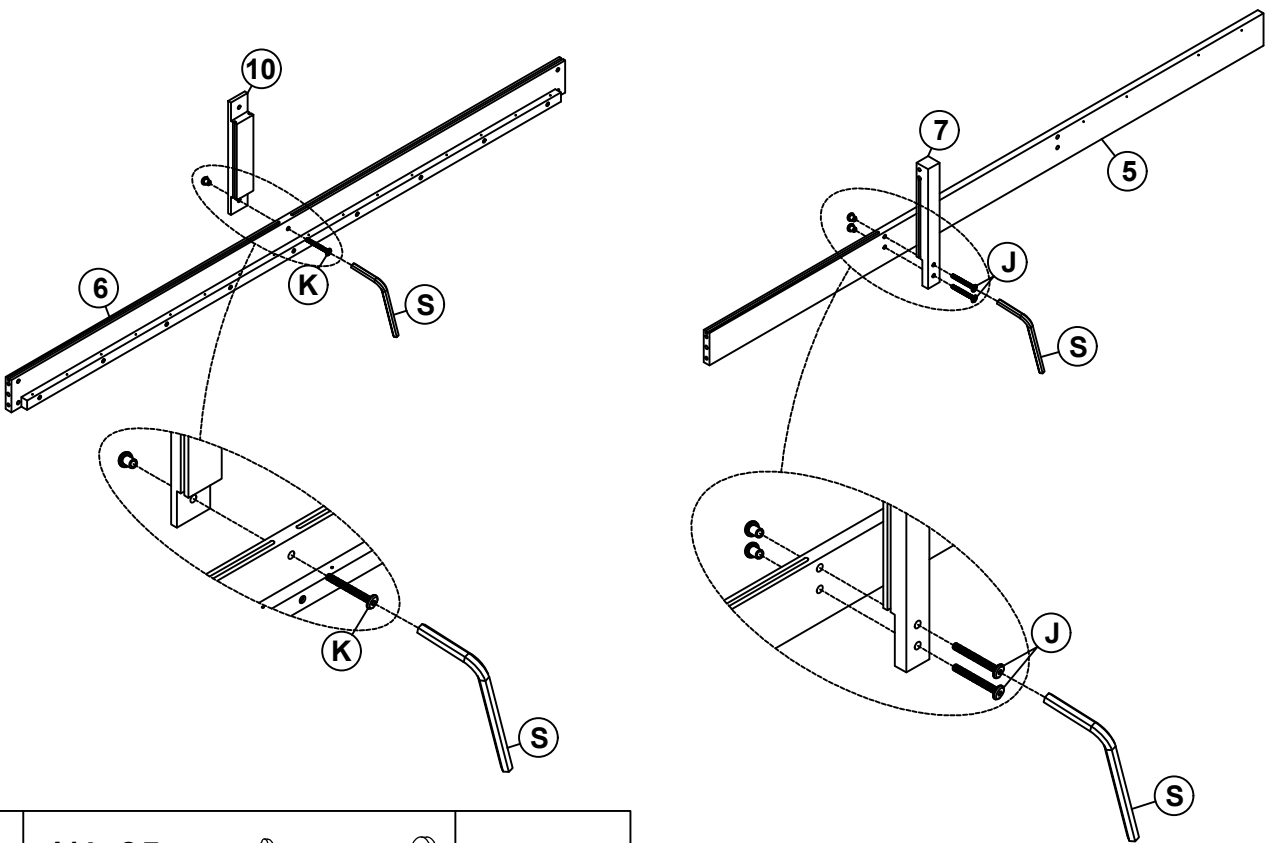
**3**



<b>J</b>	<b>1/4x35</b>		<b>2PCS</b>				
<b>K</b>	<b>1/4x25</b>		<b>1PC</b>	<b>S</b>	<b>4x58</b>		<b>1PC</b>

**4**

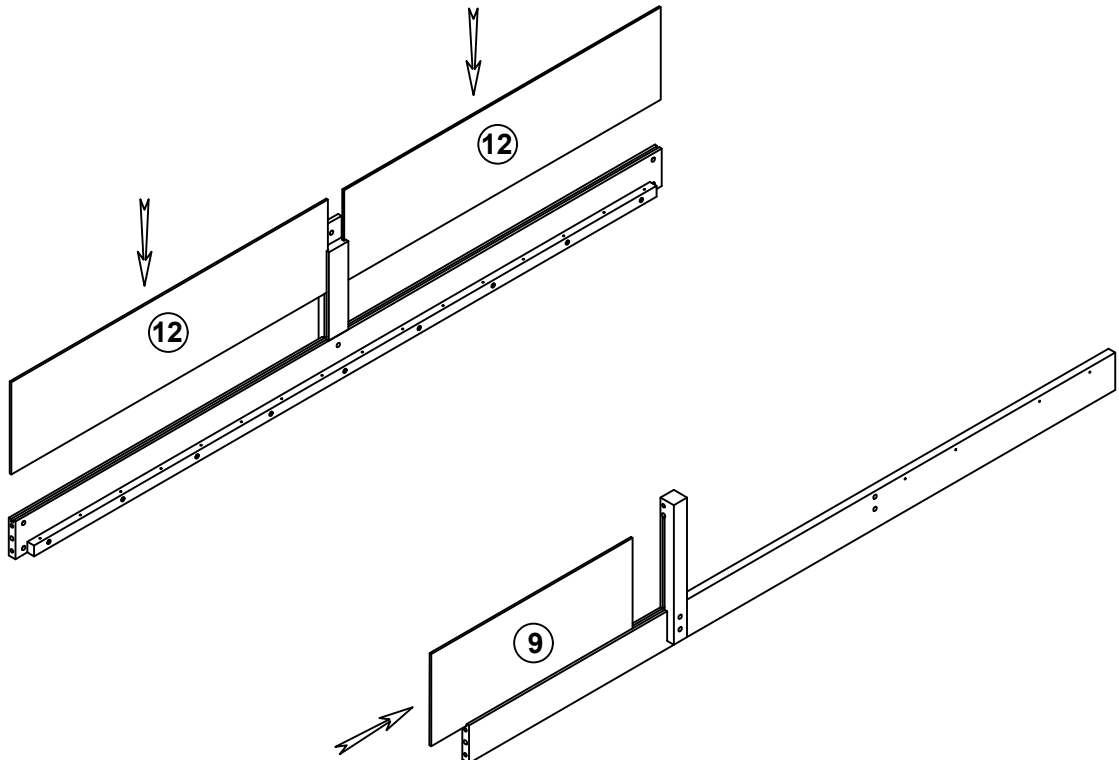

5

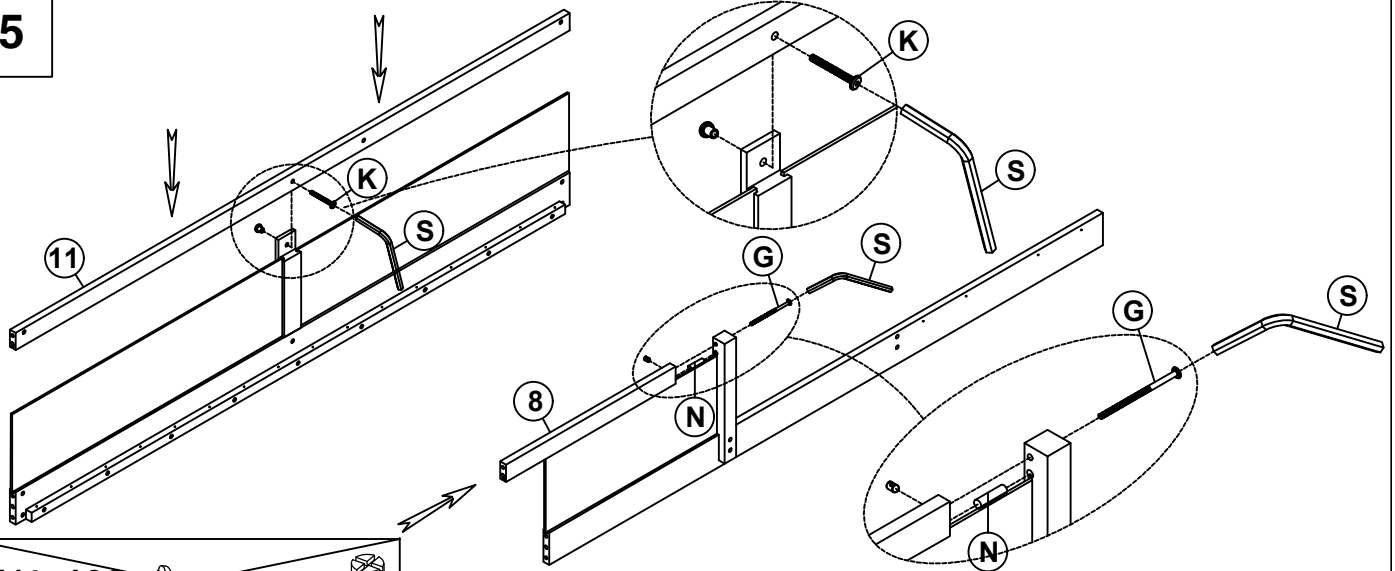

1/4x100

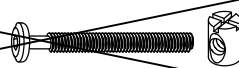

1/4x60

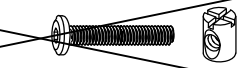

1/4x75

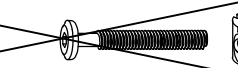

1/4x35

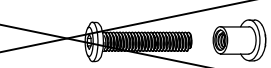

<b>G</b>	1/4x90		1PC	<b>N</b>	Ø10x40		1PC
<b>K</b>	1/4x25		1PC	<b>S</b>	4x58		1PC

6

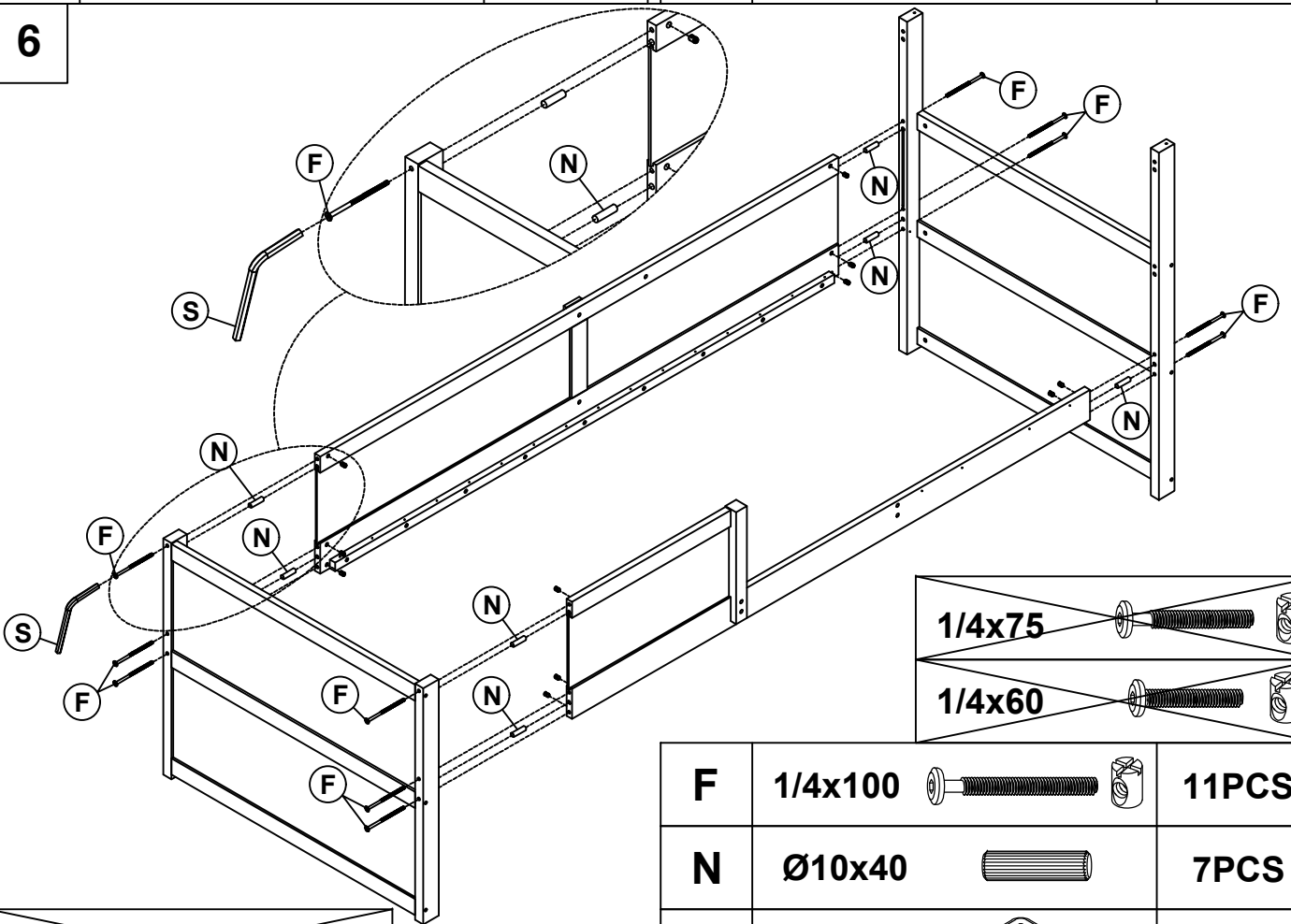

1/4x75

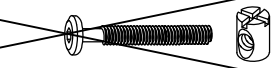

1/4x60

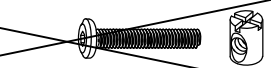

1/4x90

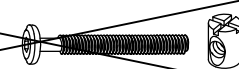

<b>F</b>	1/4x100		11PCS
<b>N</b>	Ø10x40		7PCS
<b>S</b>	4x58		1PC

7

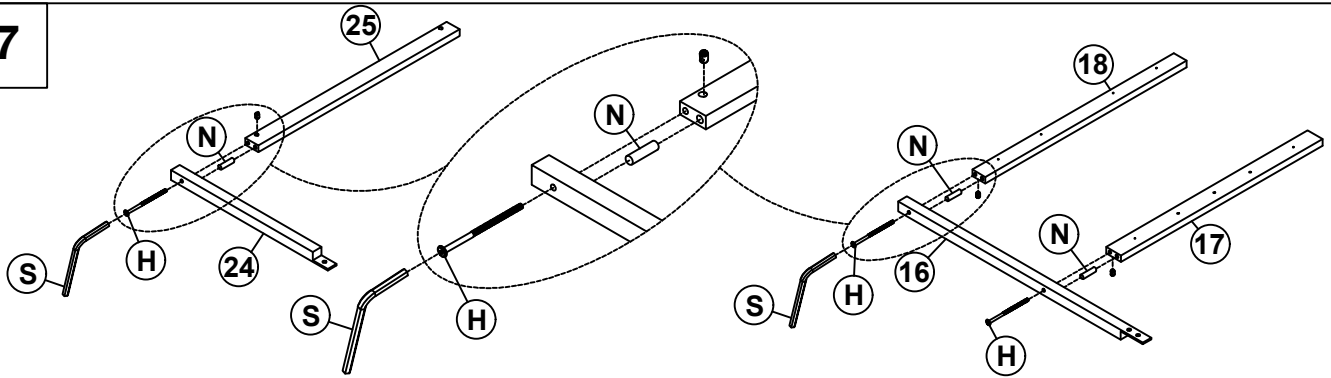

1/4x100

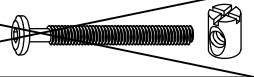

1/4x90

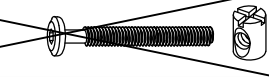

1/4x60

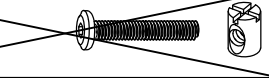

N

Ø10x40



3PCS

H

1/4x75



3PCS

S

4x58

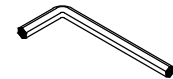

1PC

8

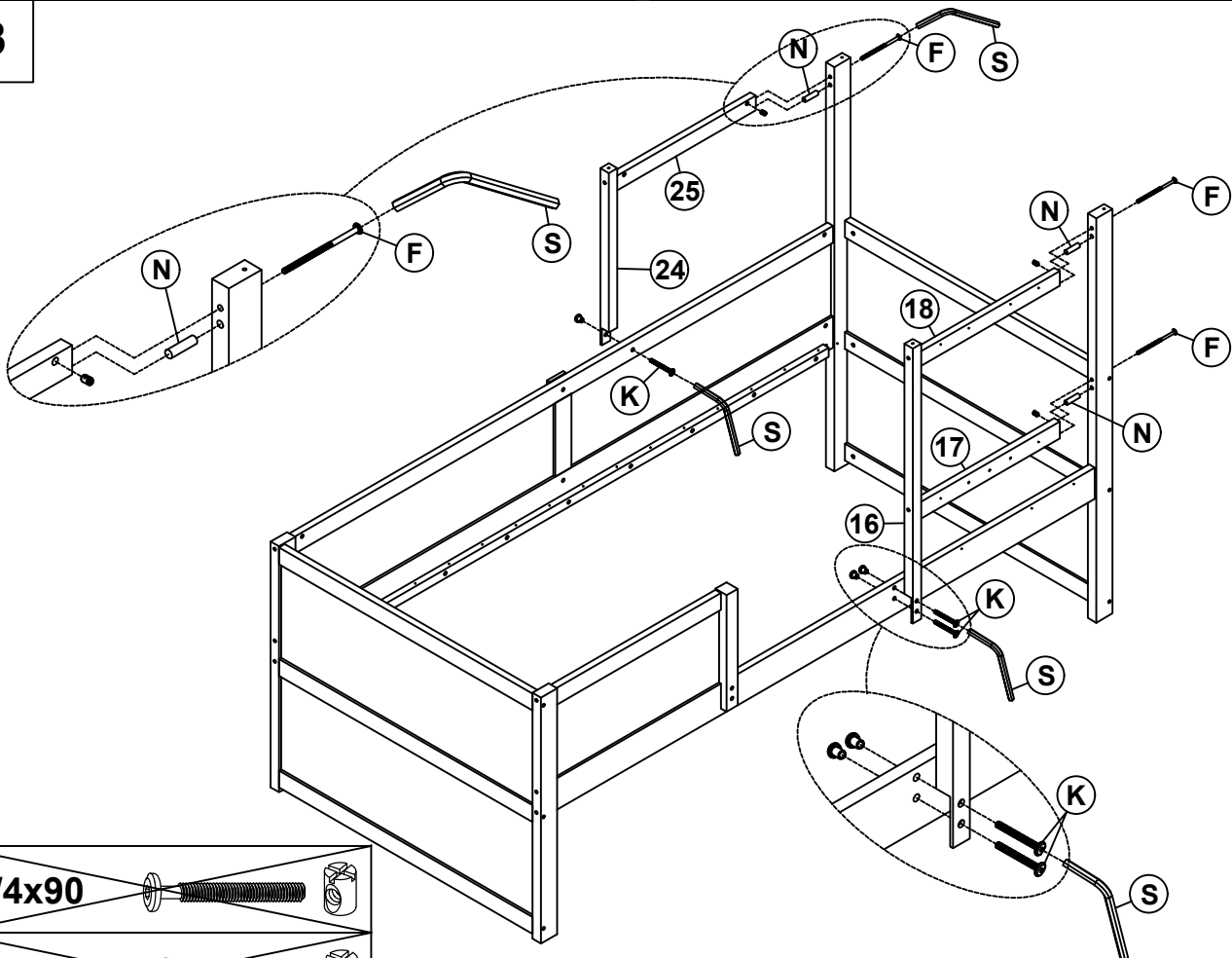

1/4x90

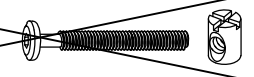

1/4x75

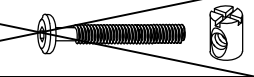

1/4x60

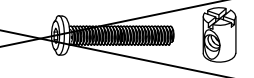

1/4x35

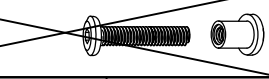

F

1/4x100



3PCS

K

1/4x25



3PCS

N

Ø10x40



3PCS

S

4x58

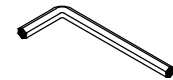

1PC

9

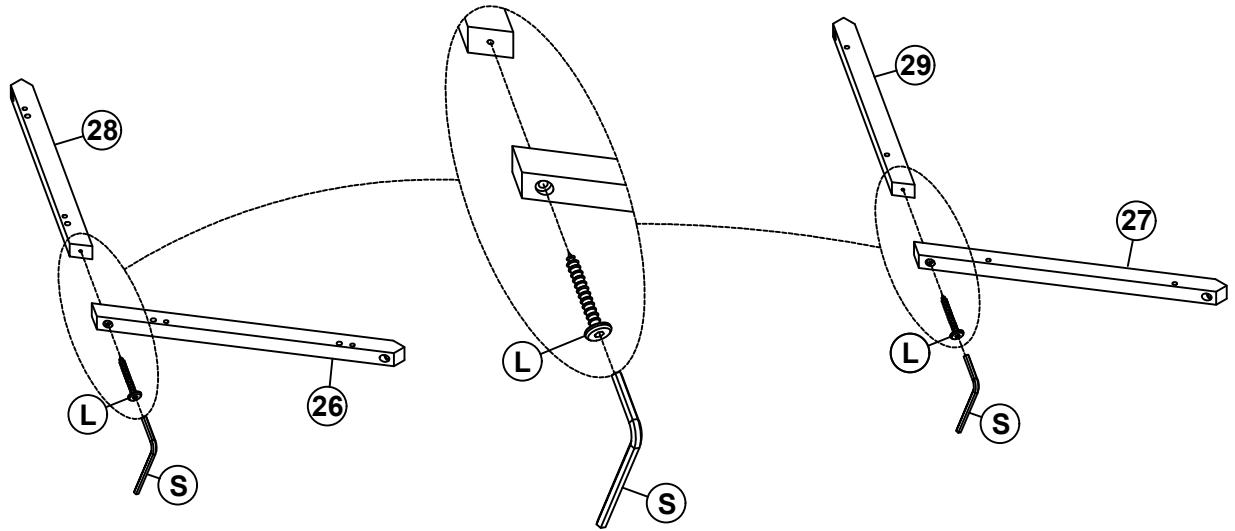

6.5x60

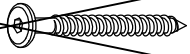

L	6.5x80		2PCS	S	4x58		1PC
---	--------	--	------	---	------	--	-----

10

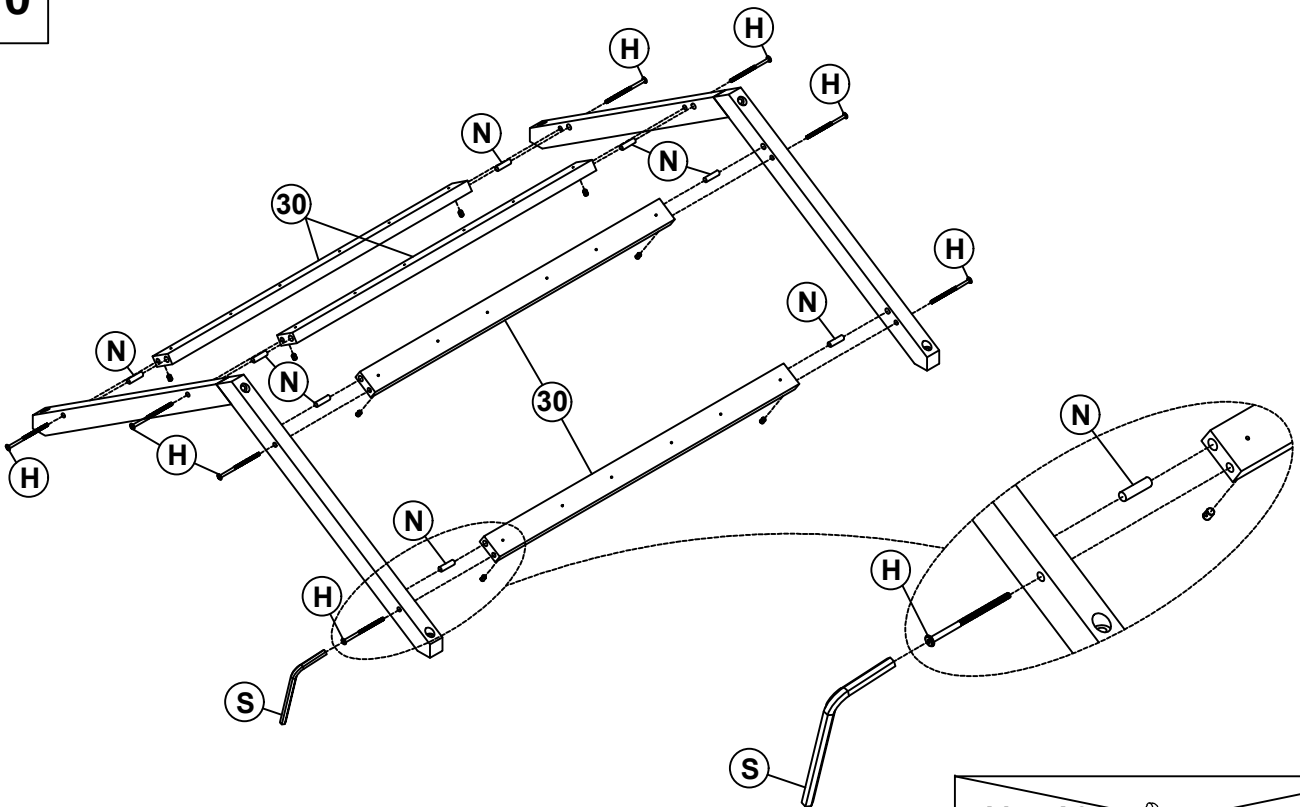

1/4x100

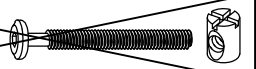

1/4x90

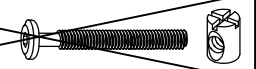

1/4x60

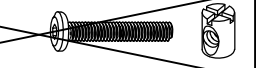

H	1/4x75		8PCS	N	Ø10x40		8PCS	S	4x58		1PC
---	--------	--	------	---	--------	--	------	---	------	--	-----

11

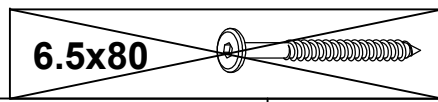
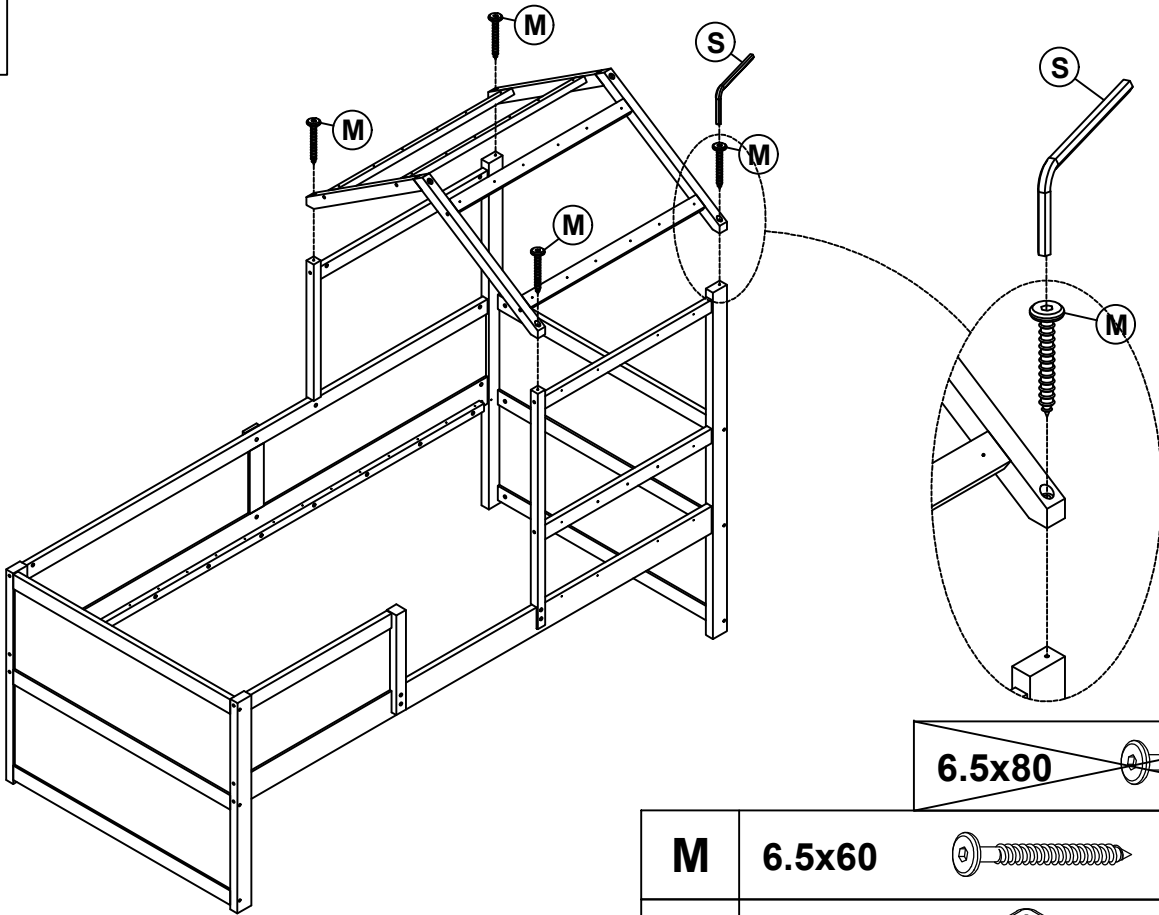

<b>M</b>	6.5x60		4PCS
<b>S</b>	4x58		1PC

12

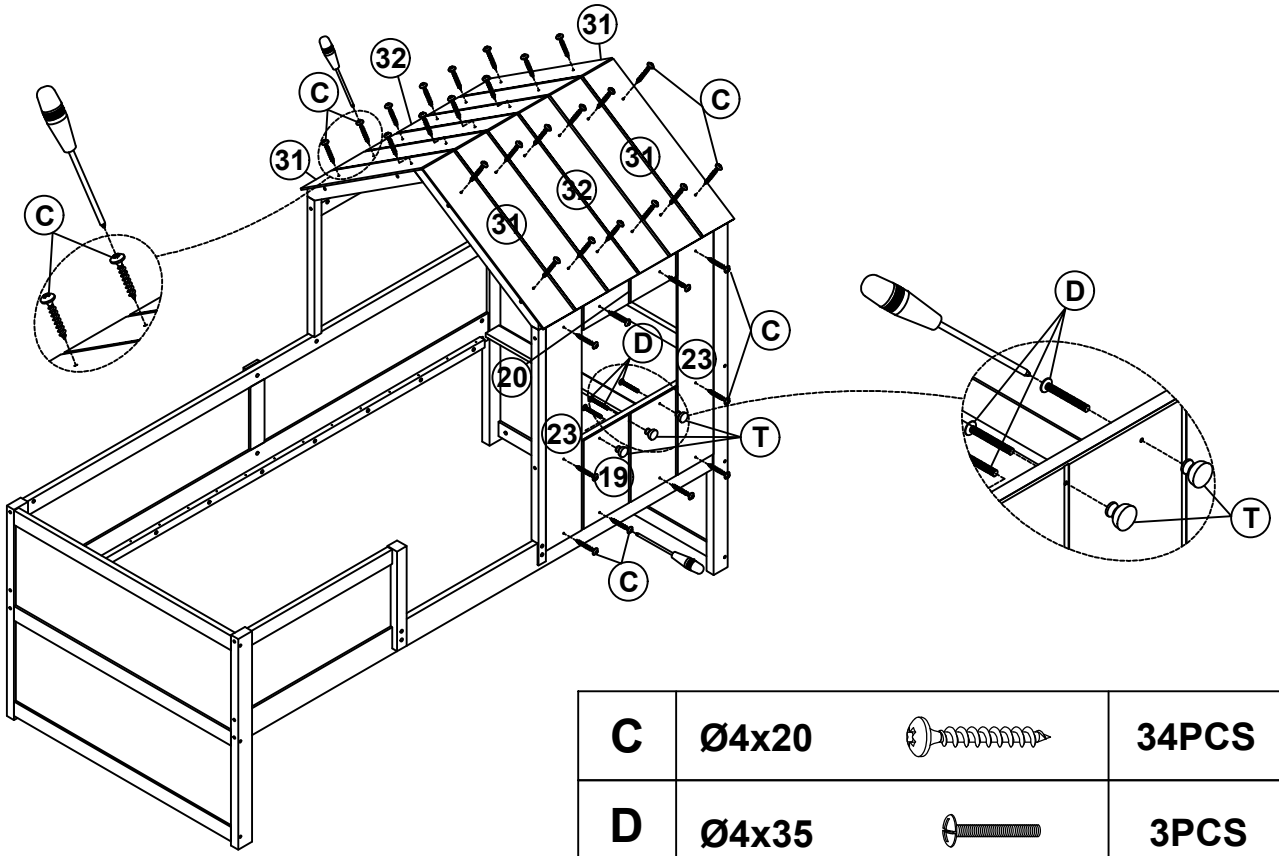

<b>C</b>	Ø4x20		34PCS
<b>D</b>	Ø4x35		3PCS
<b>T</b>	Ø28x27 (N)		3PCS

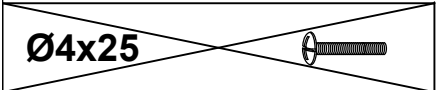



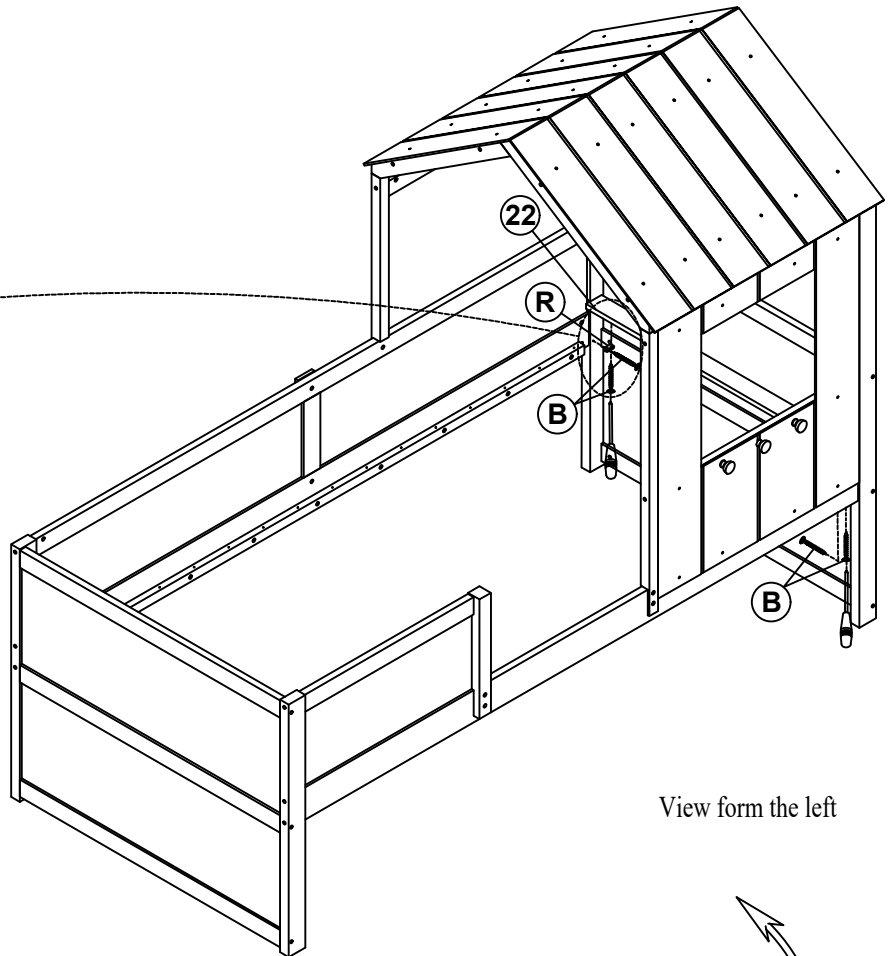
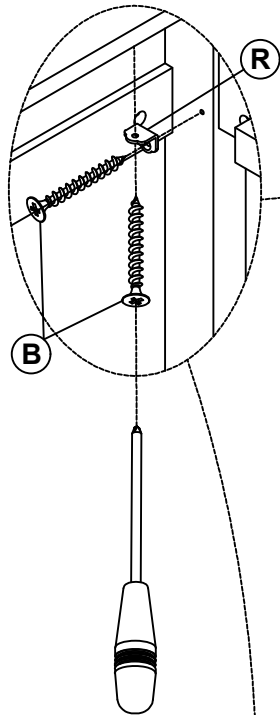

View form the left

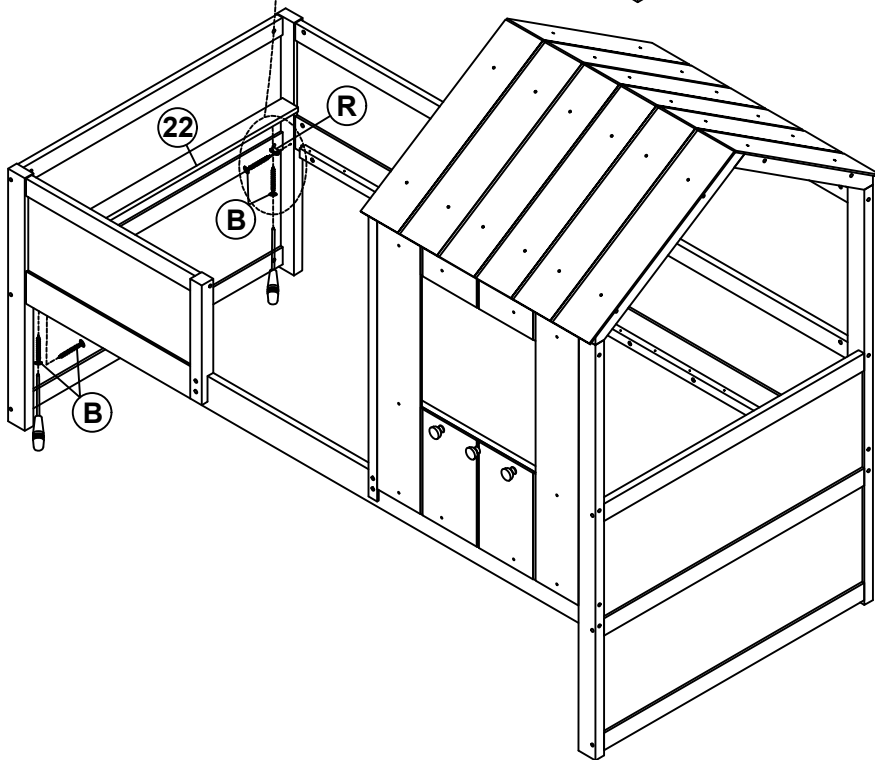

View form the right

<b>B</b>	<b>Ø4x15</b>		<b>8PCS</b>	<b>R</b>	<b>15x15x2</b>		<b>4PCS</b>
----------	--------------	---	-------------	----------	----------------	---	-------------

Befestigen Sie zunächst 2 Stück von Teil 21 an der Vorderseite und am Ende des Rahmens zwischen dem Kopfteil.  
 Dann befestigen Sie das restliche Teil 21 gleichmäßig zwischen dem Kopfteil.

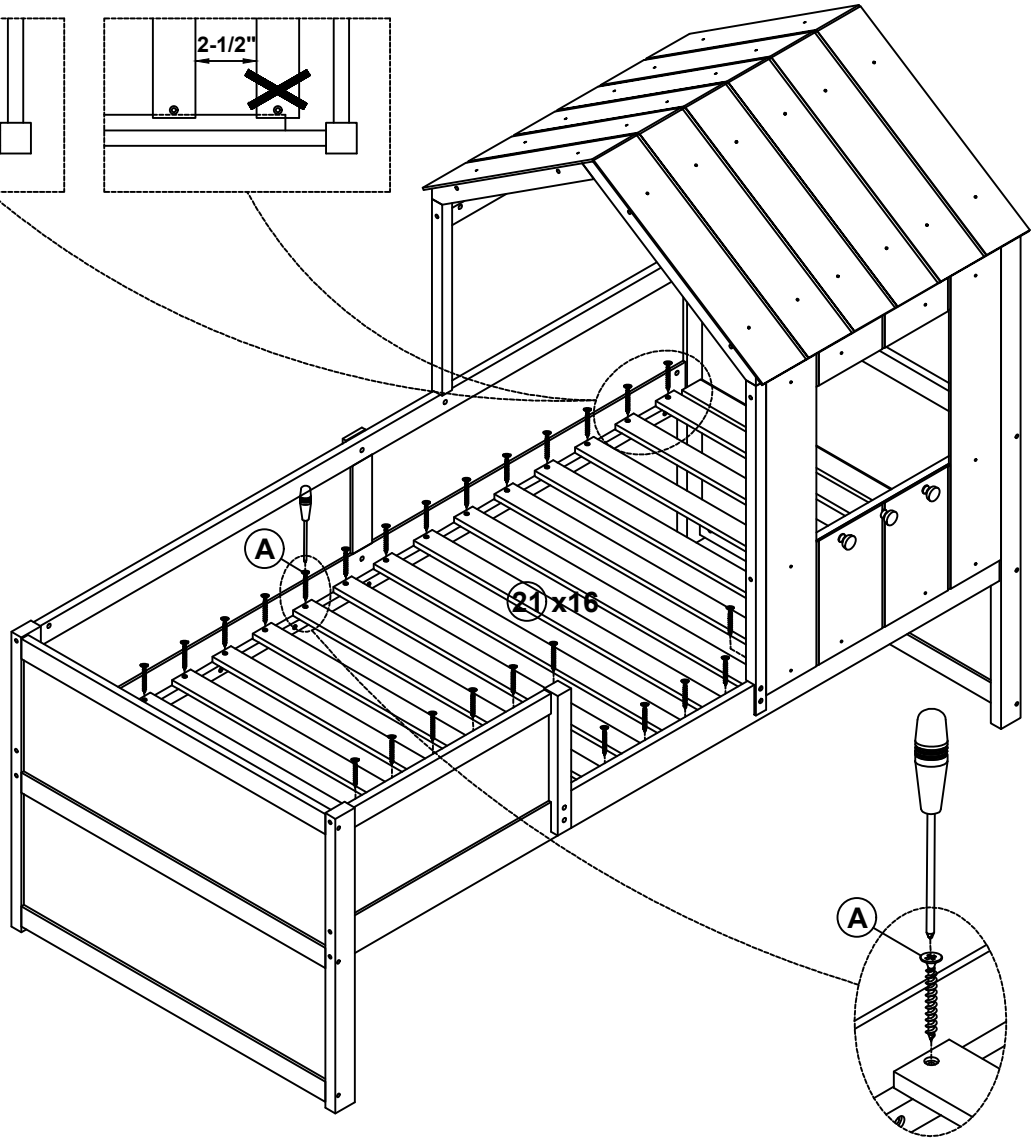
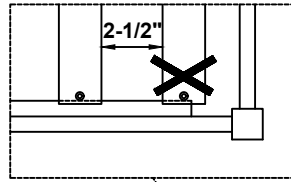
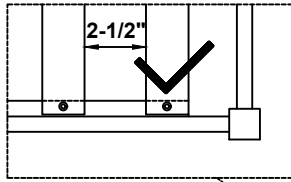

<b>A</b>	Ø4x30		<b>32PCS</b>
----------	-------	---	--------------

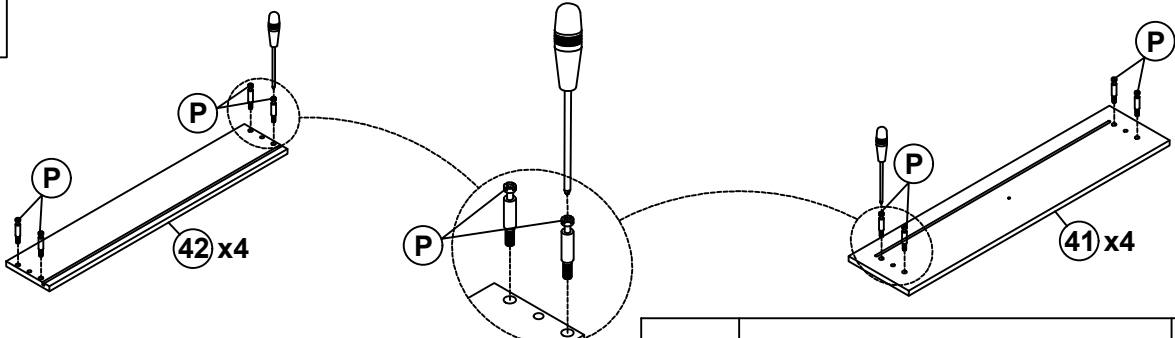
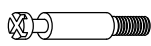
<b>15</b>			
	<b>P</b>	Ø6.5x35	 <b>32PCS</b>

16

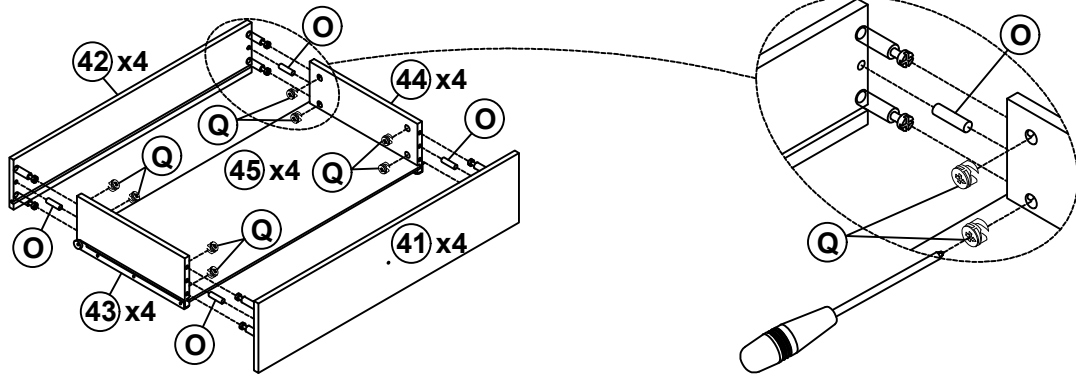

<b>Q</b>	Ø12x10		<b>32PCS</b>	<b>O</b>	Ø8x30		<b>16PCS</b>
----------	--------	--	--------------	----------	-------	--	--------------

17

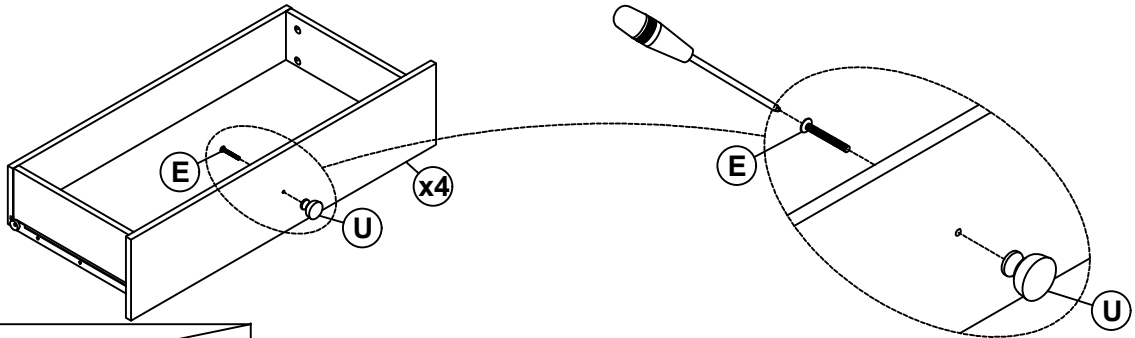

Ø4x35



<b>E</b>	Ø4x25		<b>4PCS</b>	<b>U</b>	Ø28x27 (W)		<b>4PCS</b>
----------	-------	--	-------------	----------	------------	--	-------------

18

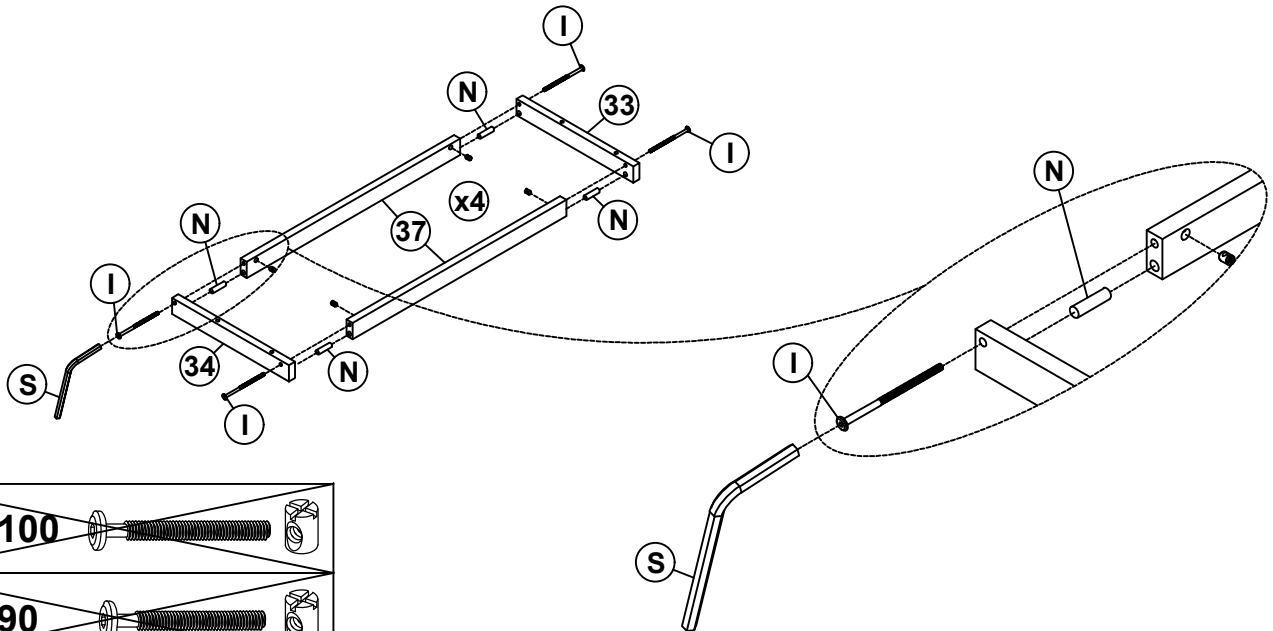

1/4x100

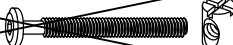

1/4x90



1/4x75



<b>N</b>	Ø10x40		<b>16PCS</b>
----------	--------	--	--------------

<b>I</b>	1/4x60		<b>16PCS</b>	<b>S</b>	4x58		<b>1PC</b>
----------	--------	--	--------------	----------	------	--	------------

19

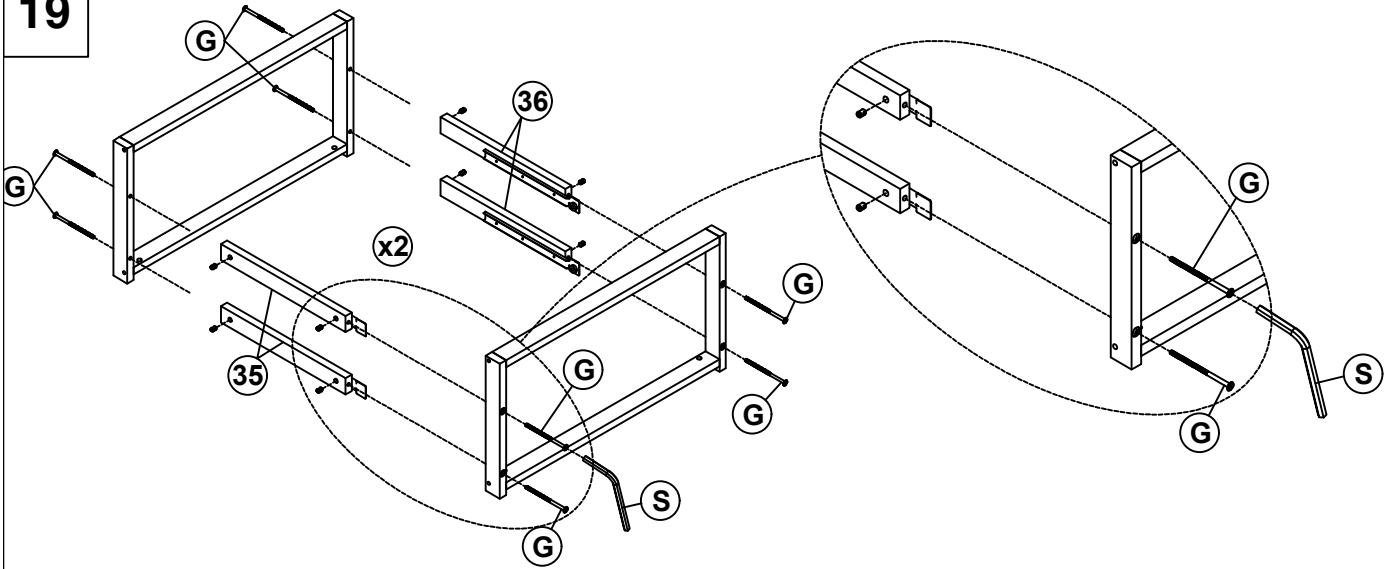

1/4x60

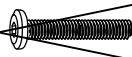

1/4x75



1/4x100

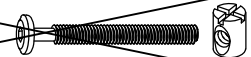

G

1/4x90



16PCS

S

4x58

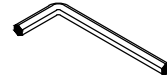

1PC

20

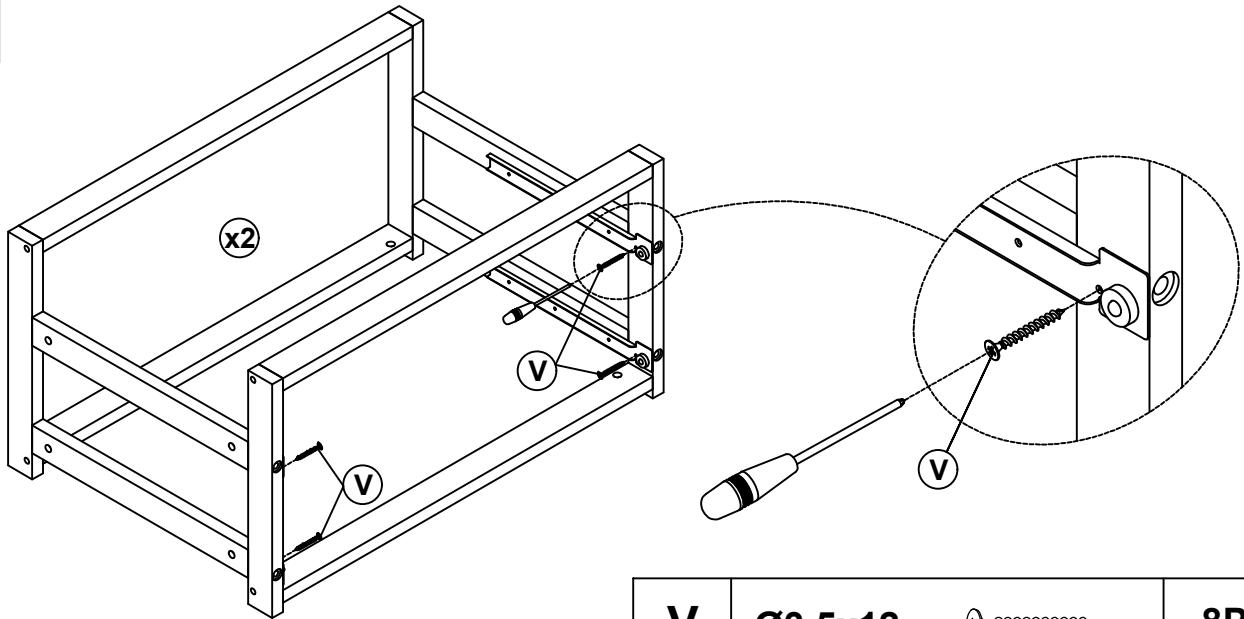

V

Ø3.5x12



8PCS

21

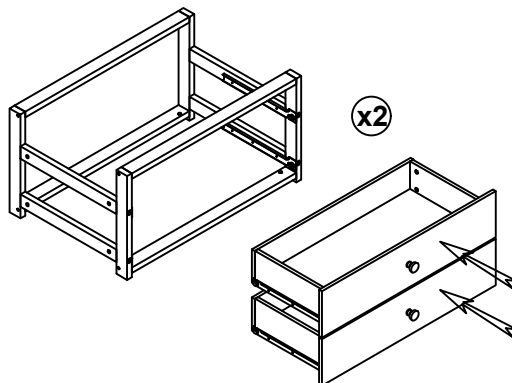

22

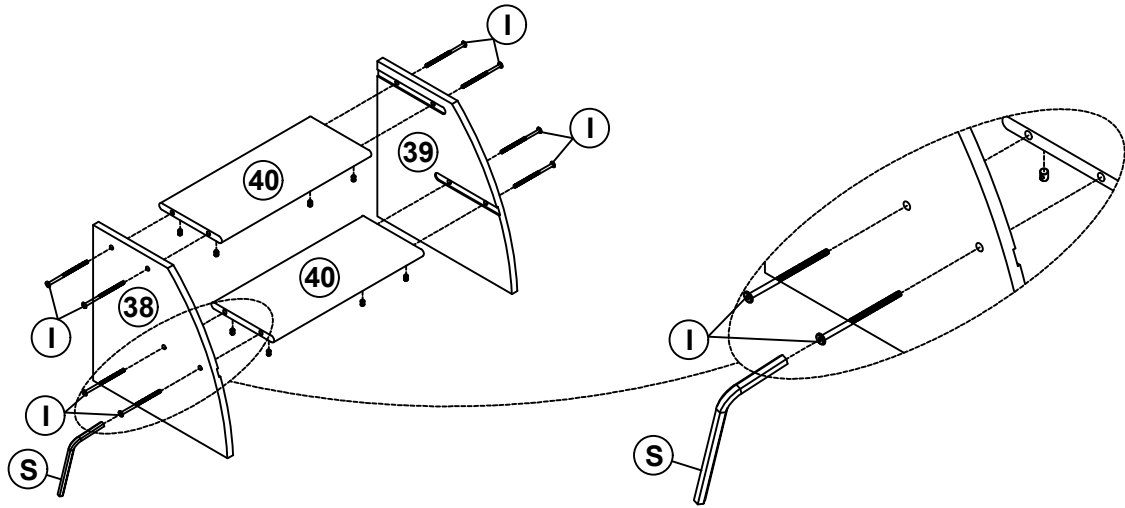

1/4x75



1/4x90



1/4x100



I

1/4x60



8PCS

S

4x58

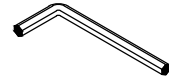

1PC

23

