

# Hausbett Kay 90/100

## (45x45)

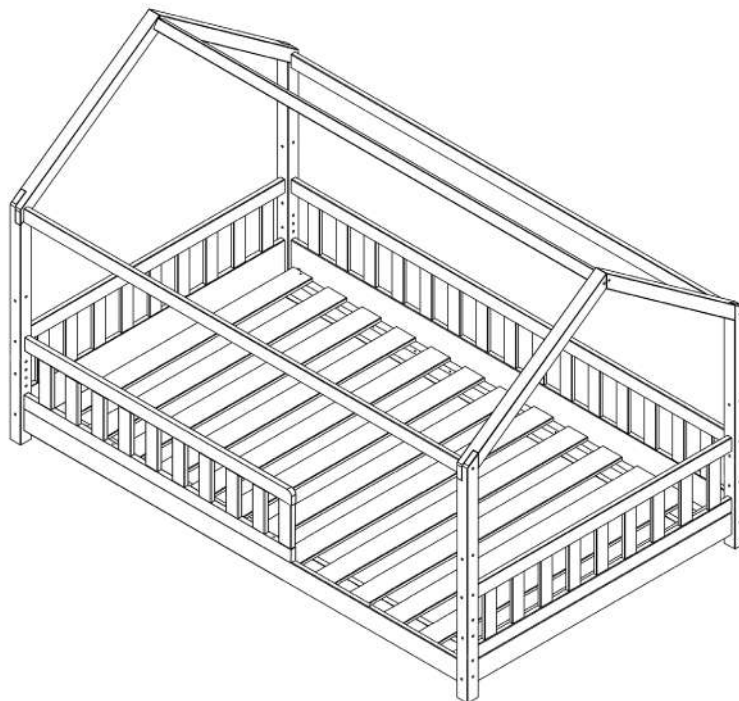

**D** Gebrauchsanweisung

**NL** Gebruiksrichtlijnen

**IT** Istruzioni per l'uso

**CZ** Pokyny k použití

**HU** Használati útmutató

**PT** Instruções de utilização

**SK** Pokyny k použití

**GB** Instructions for use

**FR** Instructions d'utilisation

**PL** Instrukcja obsługi

**ES** Instrucciones de empleo

**RO** Instrucțiuni de folosire

**RU** Инструкция по монтажу

**TR** Kullanım talimatları



HAUSBETT

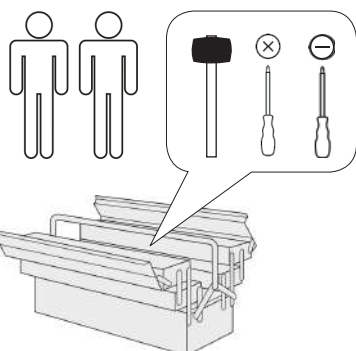

**2H**



MVH GmbH & Co. KG  
August-Thyssen-Str.8-10  
32278 Kirchlengern  
Tel.: +49(0) 5223 - 65335 0  
Mail: [info@ticaa.de](mailto:info@ticaa.de)

## VARIANTEN HAUSBETT

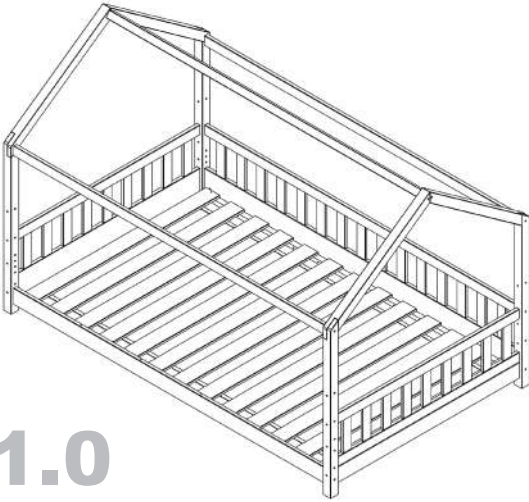

**1.0**

**Bodenbett**  
ohne Rausfallschutz S. 5-6

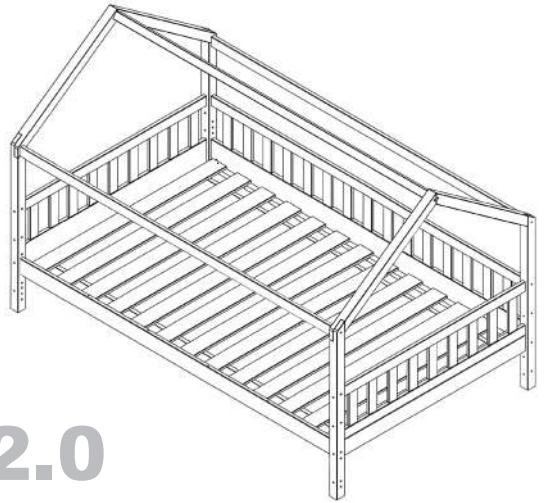

**2.0**

**Hausbett**  
ohne Rausfallschutz S. 8-9

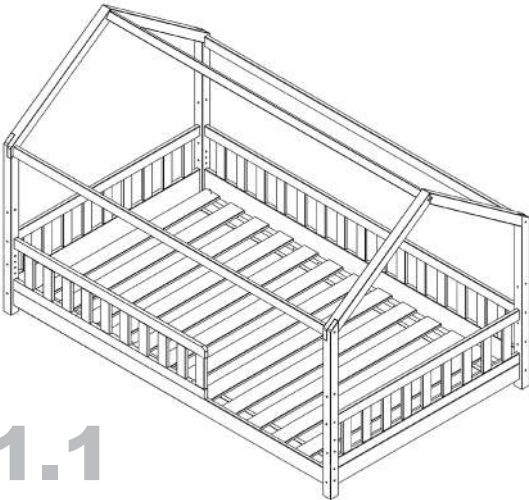

**1.1**

**Bodenbett**  
Rausfallschutz links S. 7

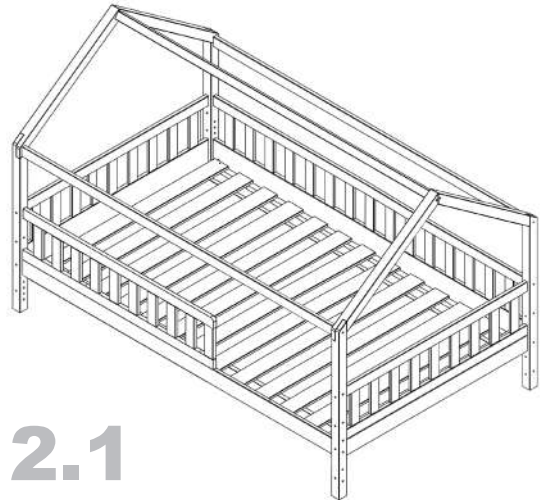

**2.1**

**Hausbett**  
Rausfallschutz links S. 10

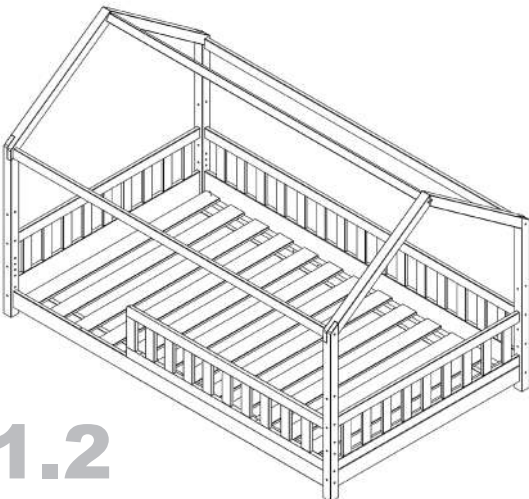

**1.2**

**Bodenbett**  
Rausfallschutz rechts S. 7

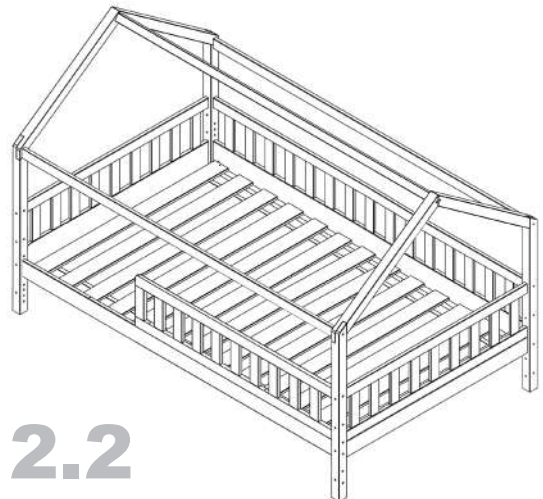

**2.2**

**Hausbett**  
Rausfallschutz rechts S. 10

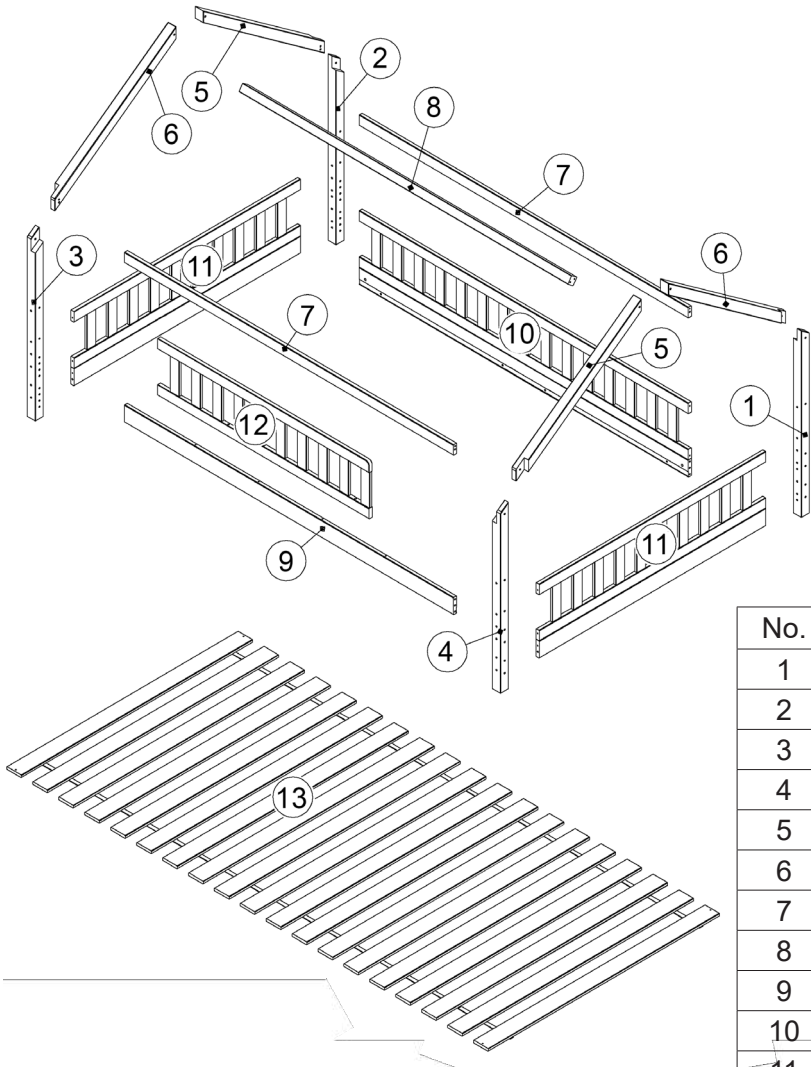
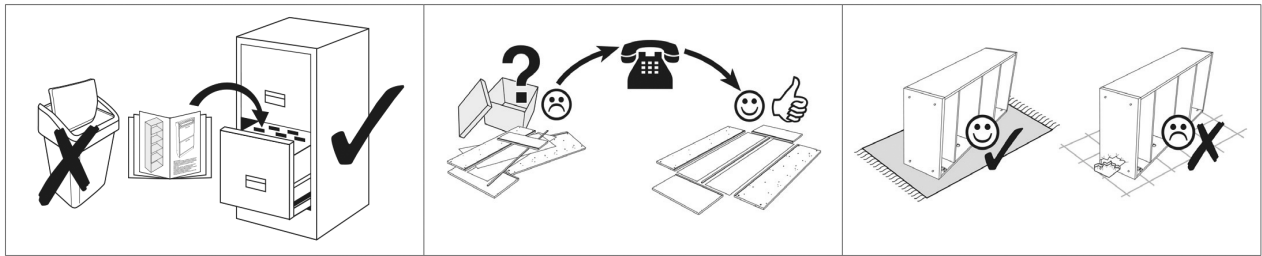

No.	L	B	T	Pcs.	Colli
1	966	45	45	1	2
2	966	45	45	1	2
3	966	45	45	1	2
4	966	45	45	1	2
5	629/691	45	45	2	2
6	629/691	45	45	2	2
7	1975	55	20	2	1
8	1975	45	45	1	1
9	1975	90	50	1	1
10	1975	384	45	1	1
11	875/975	384	20	2	1
12	1280	294	20	1	1
13	1950	898/998	8	17	2

<b>A17</b>  10x30 mm      4x	<b>A16</b>  8x40 mm      16x	<b>J48</b>  SW 4      1x	<b>D47</b>  3,5x30 mm      2x
<b>P53</b>  6,3x80 mm      20x	<b>P251</b>  7x80 mm      2x	<b>P178</b>  M6x90 mm      4x	<b>P202</b>  M6x35 mm      2x
<b>R4</b>  M6x10x13 mm      4x	<b>R29</b>  M6x8x15 mm      2x	<b>S39</b>  60x	<b>G</b>  PVC 5 mm      4x

# 1

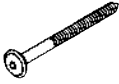
**P53**

6,3x80 mm

4x

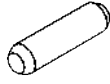
**A16**

8x40 mm

16x

**J48**

SW 4

1x

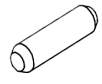
**A17**

10x30 mm

4x

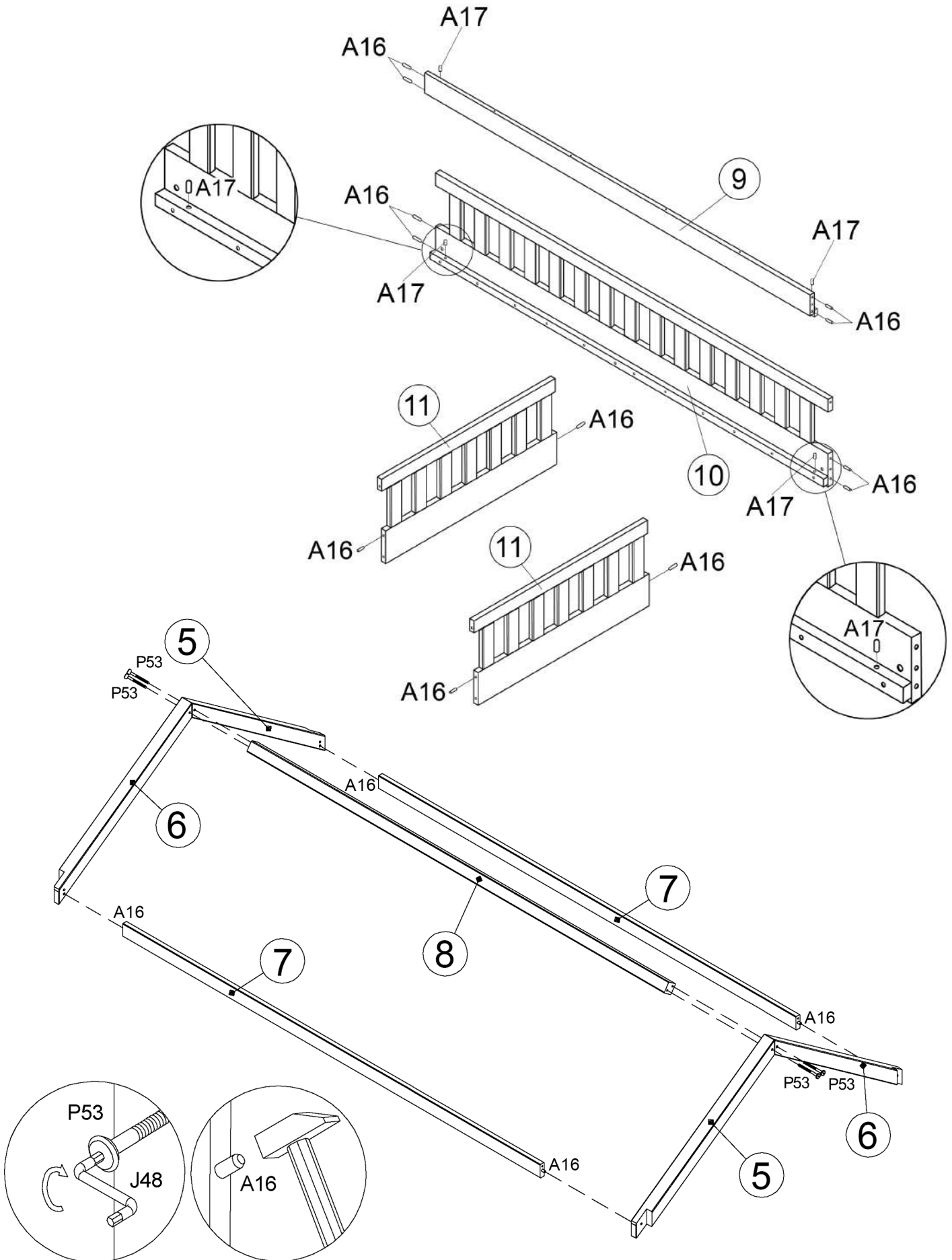

# 2

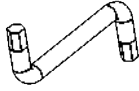
**J48**

SW 4

**1x****P53**

6,3x80 mm

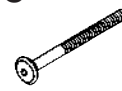
**14x****P178**

M6x90 mm

**4x****R4**

M6x10x13 mm

**4x**

## VARIANTE 1.0

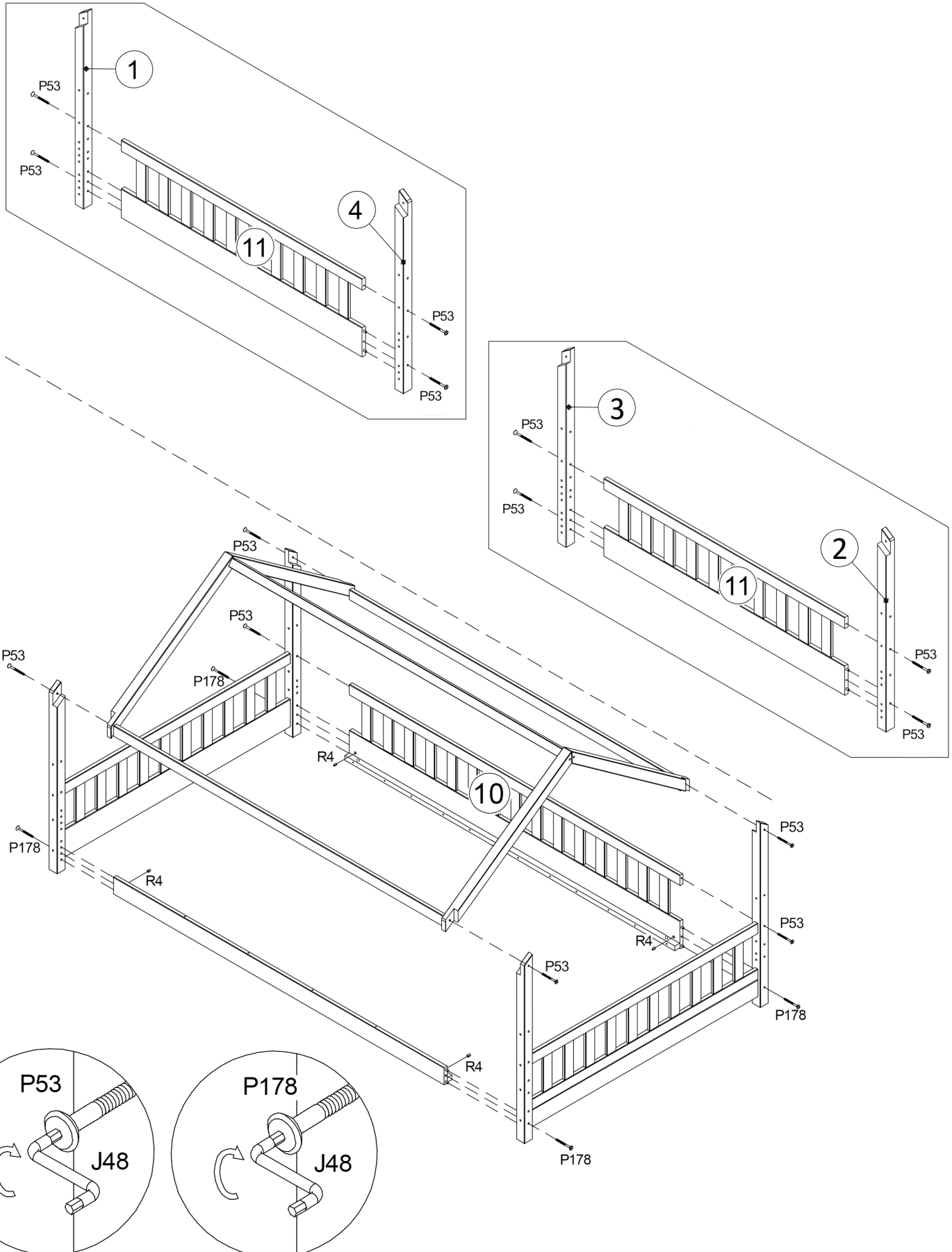

# 3

D47



3,5x30 mm

2x

## VARIANTE 1.0

**i**

### Hinweis

Bitte achten Sie darauf, dass die letzten Latten vom Rollrost hinter dem Dübel A17 liegen und nicht verschraubt werden.

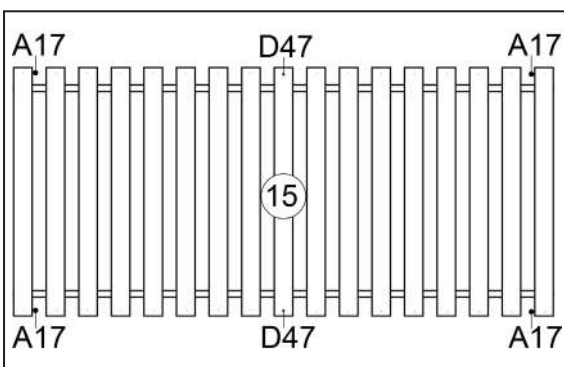
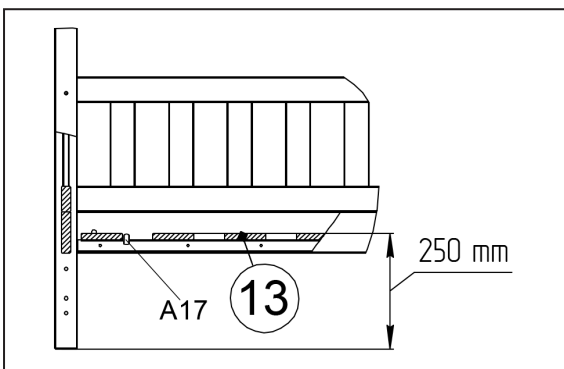
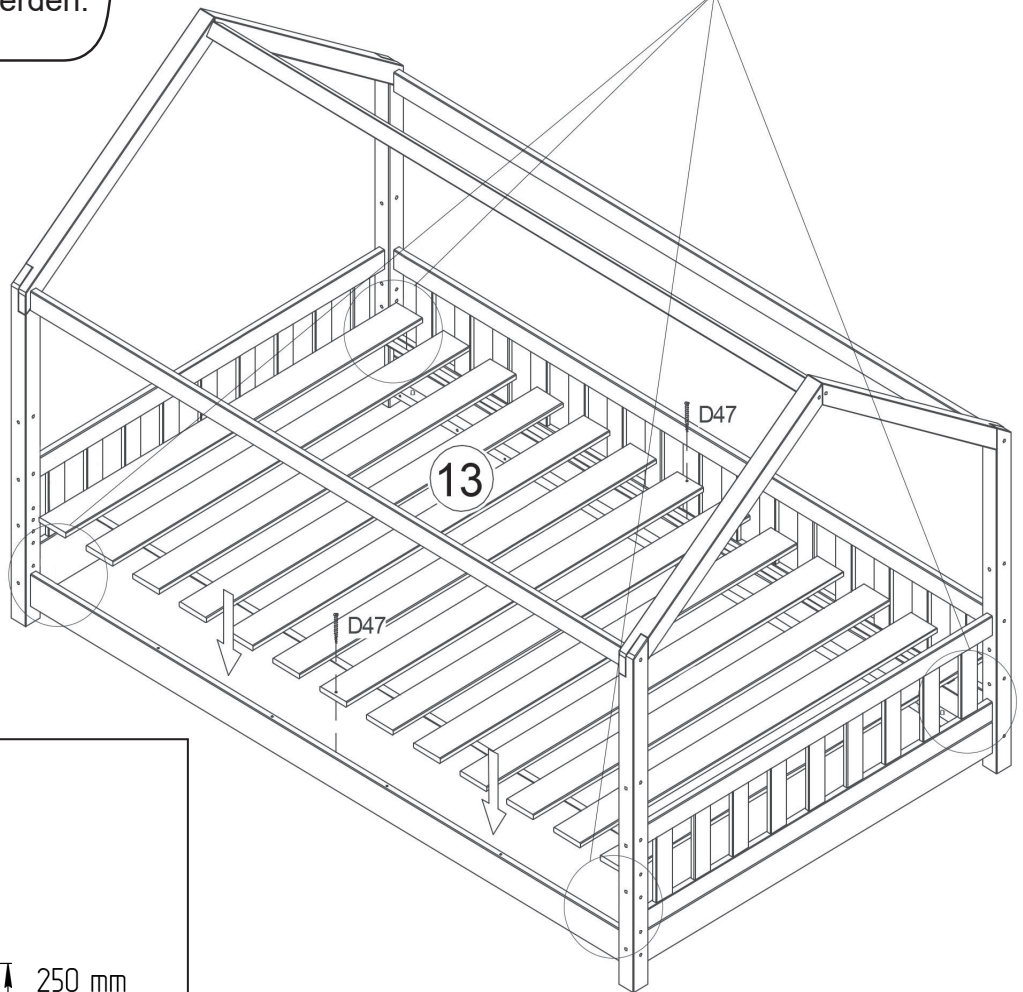
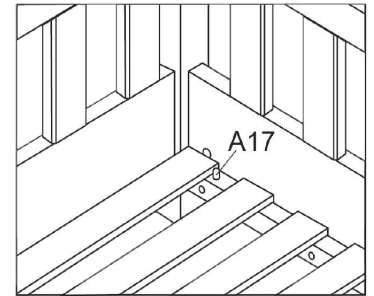

**i**

### Hinweis

Rollrost ist mit mehreren Betten kompatibel. Bitte **NUR** die hier gezeigten Bohrungen mit D47 verschrauben.

# 4

**J48**

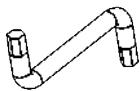

SW 4

1x

**P251**



7x80 mm

2x

**P53**

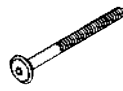

6,3x80 mm

2x

## VARIANTE 1.1 Rausfallschutz links

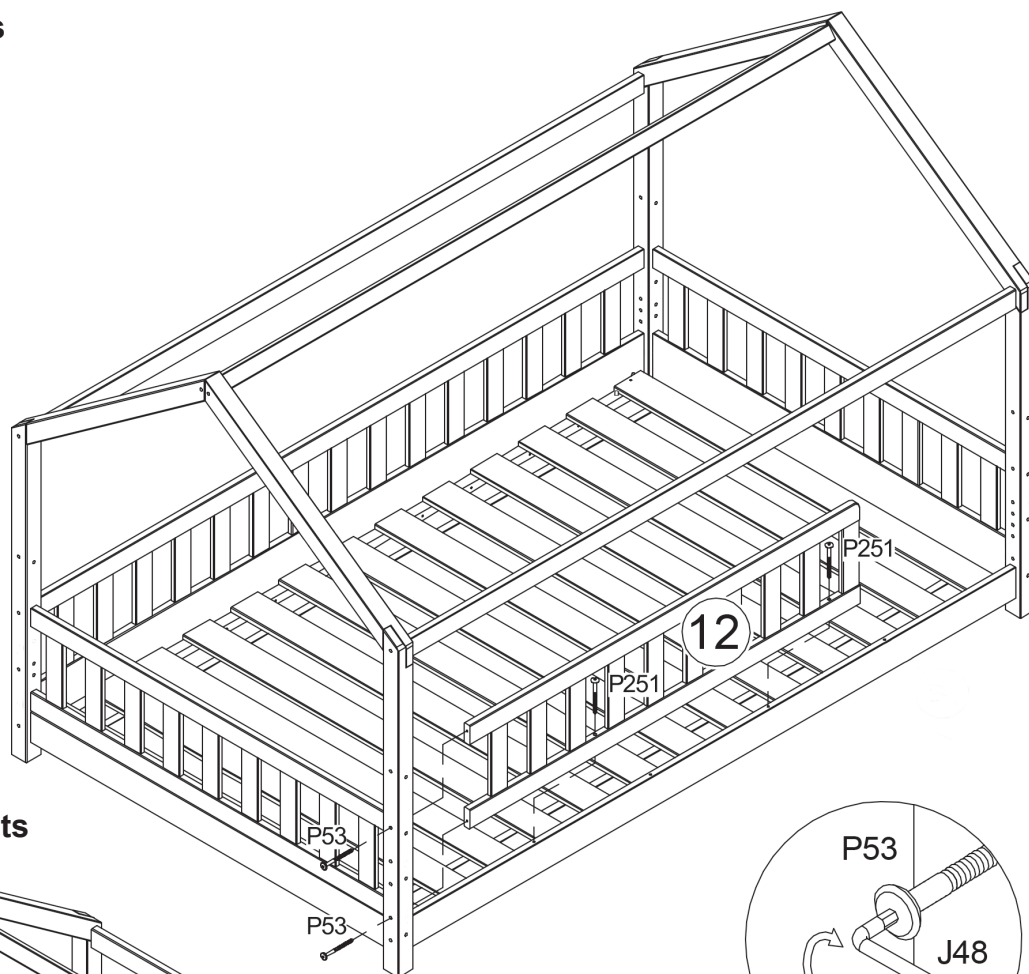

## VARIANTE 1.2 Rausfallschutz rechts

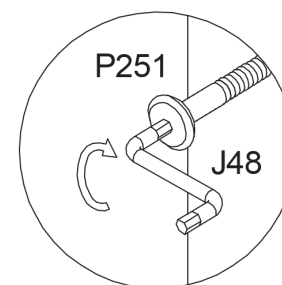
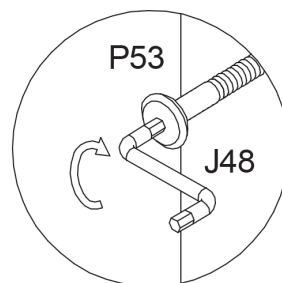
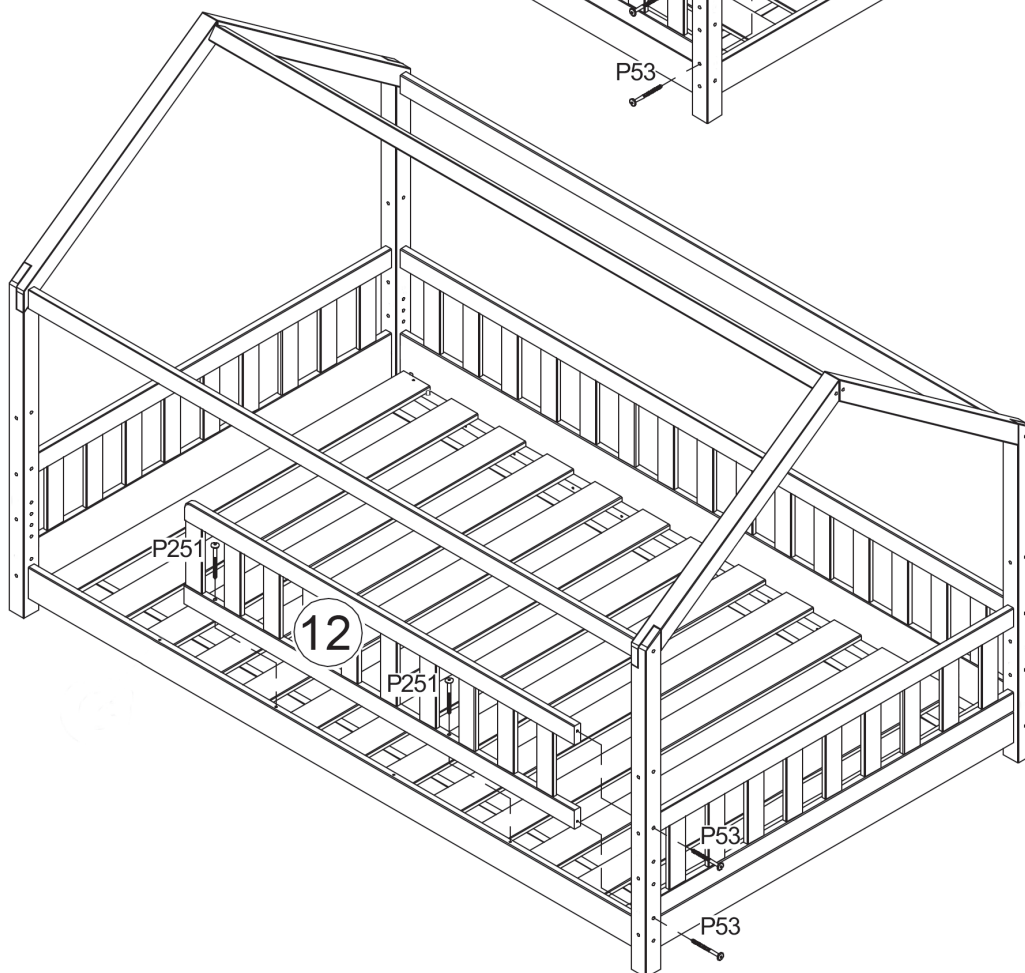

# 5

**J48**

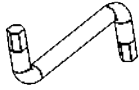

SW 4

1x

**P53**



6,3x80 mm

14x

**P178**

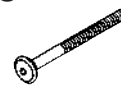

M6x90 mm

4x

**R4**



M6x10x13 mm

4x

## VARIANTE 2.0

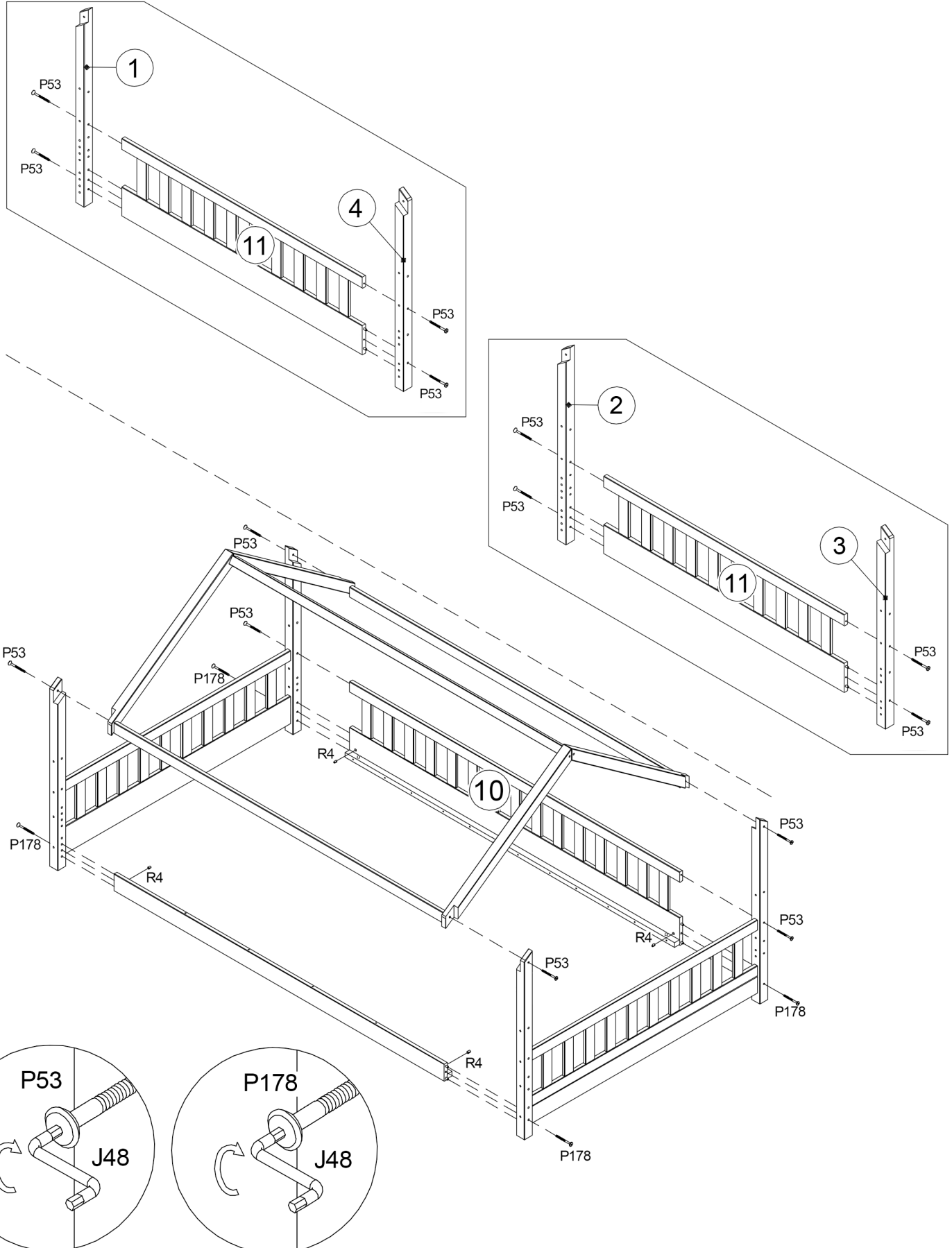



# 6

## D47

3,5x30 mm



2x

### VARIANTE 2.0

**i**

#### Hinweis

Bitte achten Sie darauf, dass die letzten Latten vom Rollrost hinter dem Dübel A17 liegen und nicht verschraubt werden.

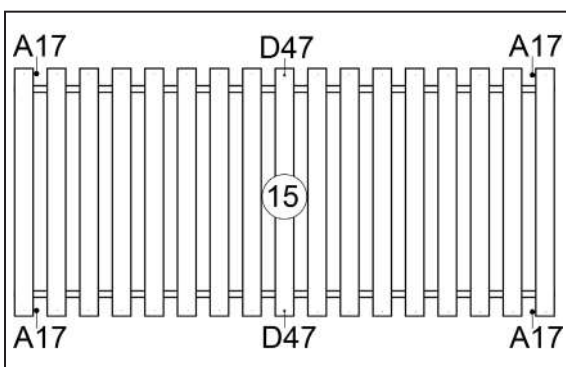
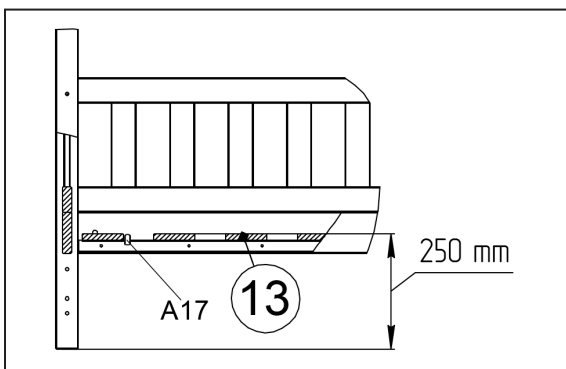
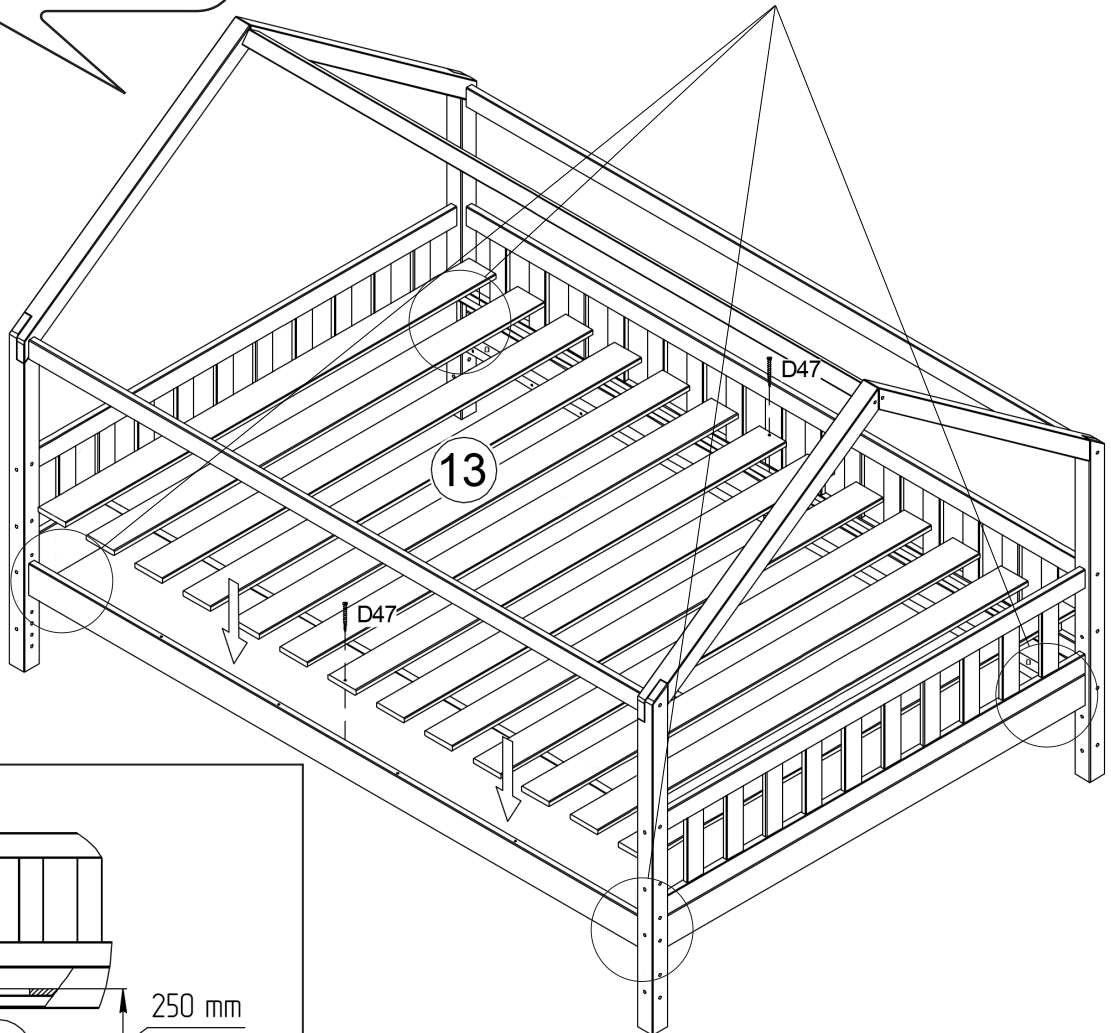
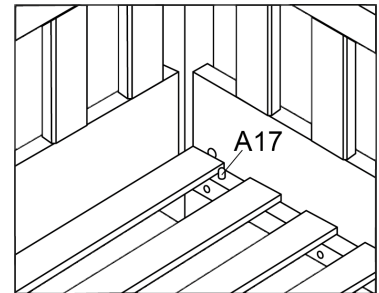

**i**

#### Hinweis

Rollrost ist mit mehreren Betten kompatibel. Bitte **NUR** die hier gezeigten Bohrungen mit D47 verschrauben.

# 7

**J48**

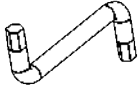

SW 4

1x

**P251**



7x80 mm

2x

**P53**



6,3x80 mm

2x

## VARIANTE 2.1 Rausfallschutz links

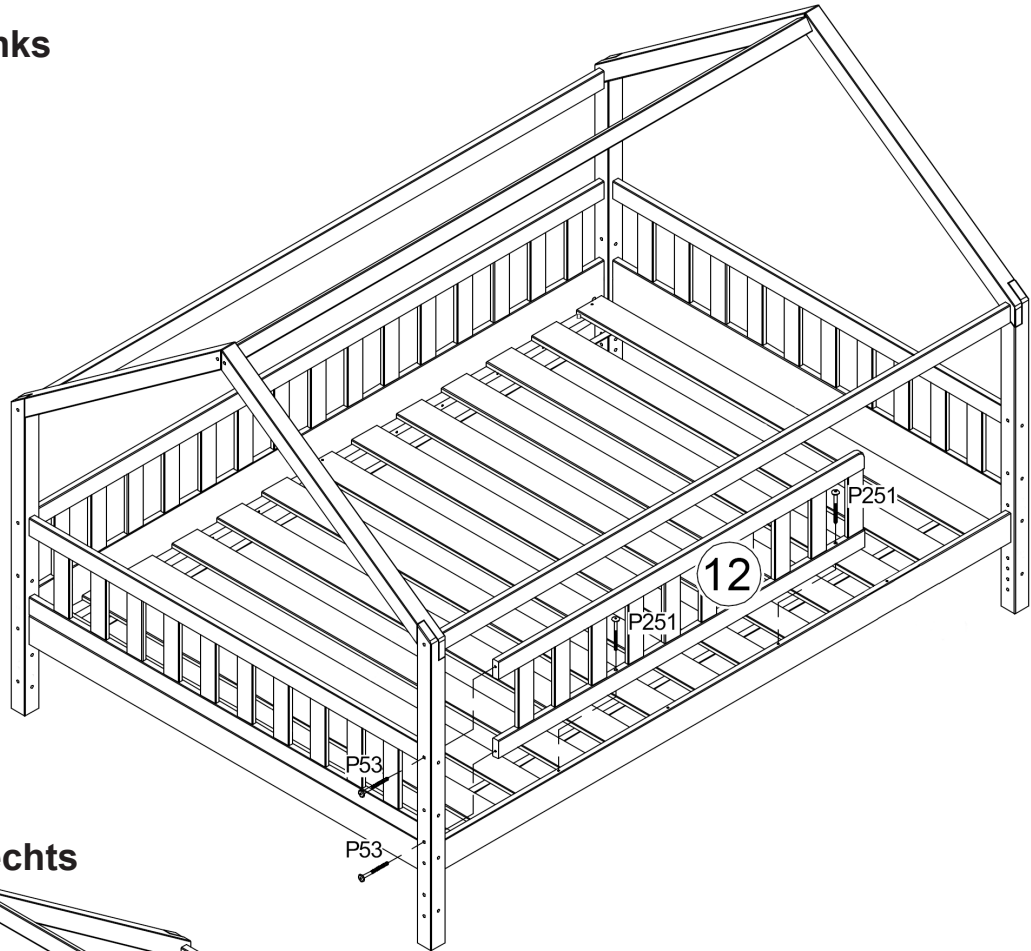

## VARIANTE 2.2 Rausfallschutz rechts

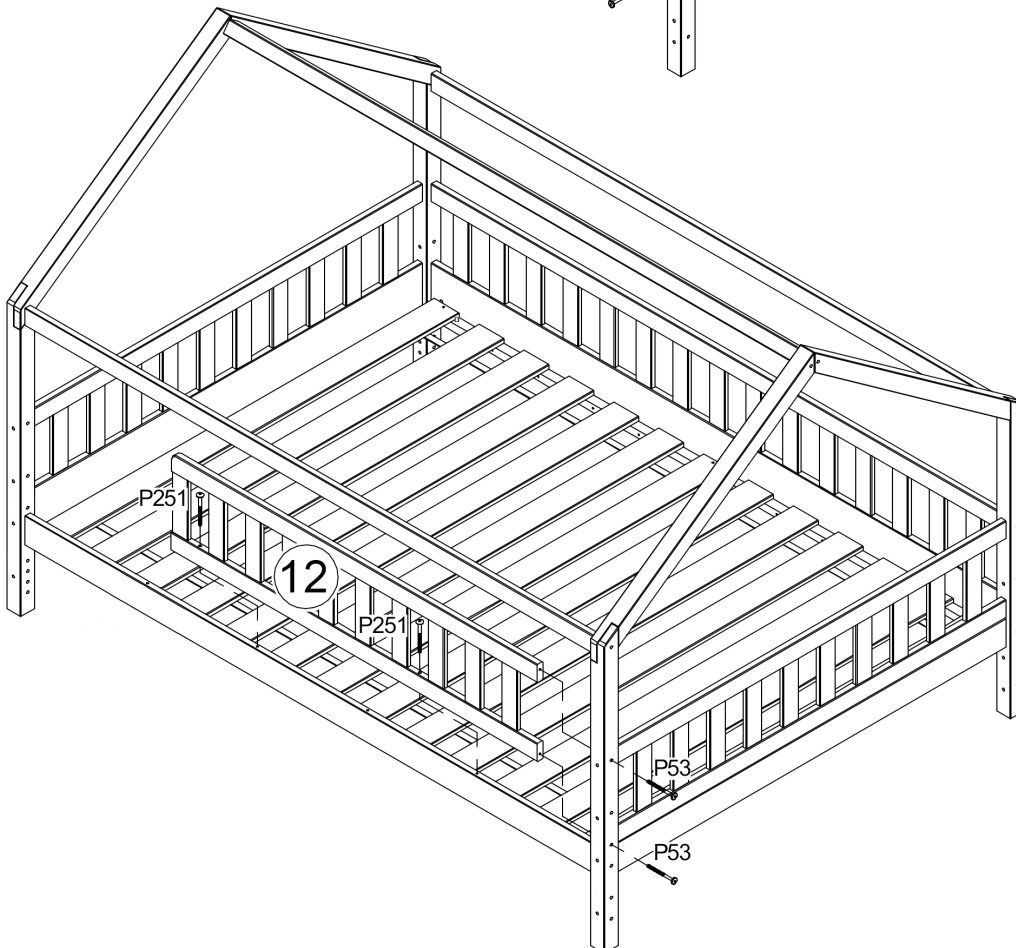

# 8

S39



60x

G



PVC 5 mm

4x

## Bodenbett

VARIANTE 1.0/ 1.1/ 1.2

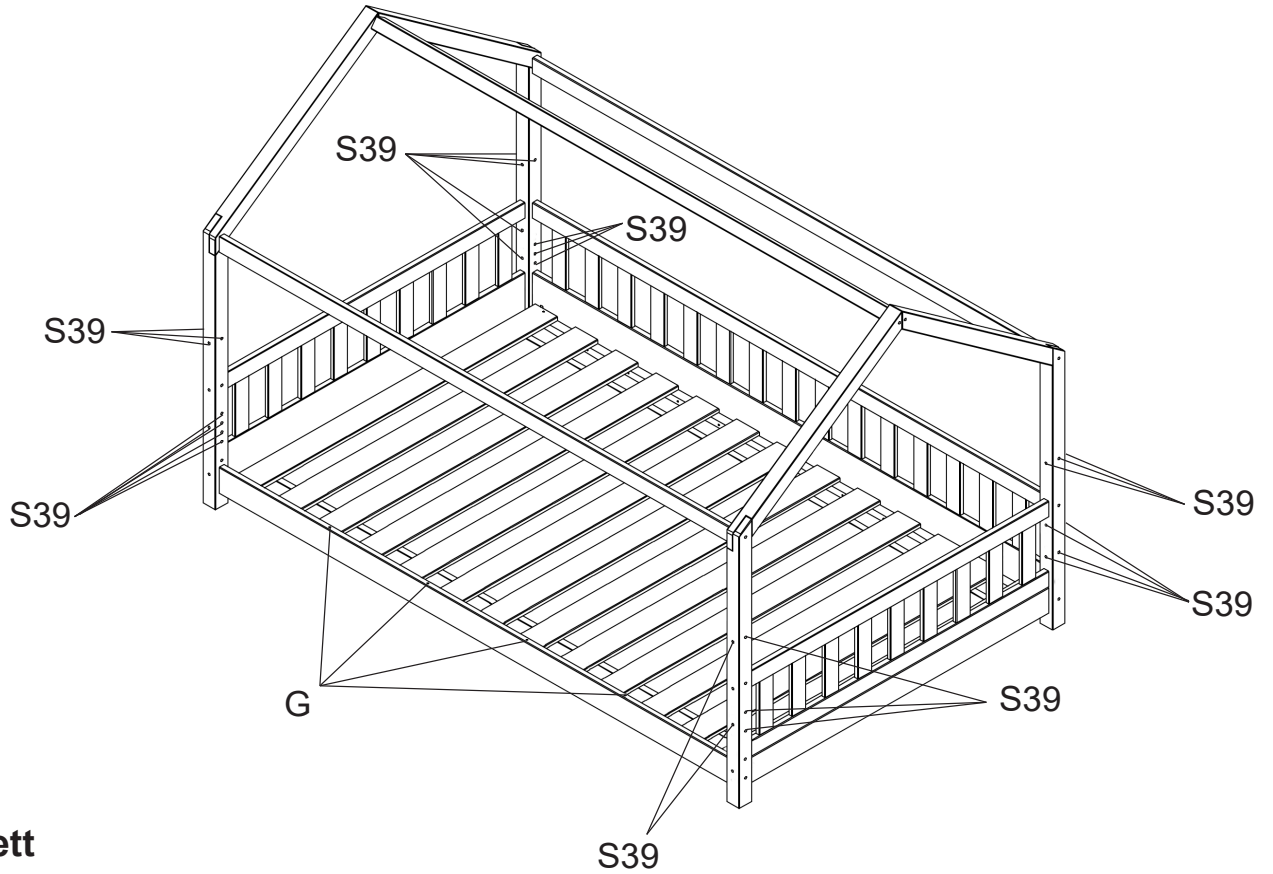

## Hausbett

VARIANTE 2.0/ 2.1/ 2.2

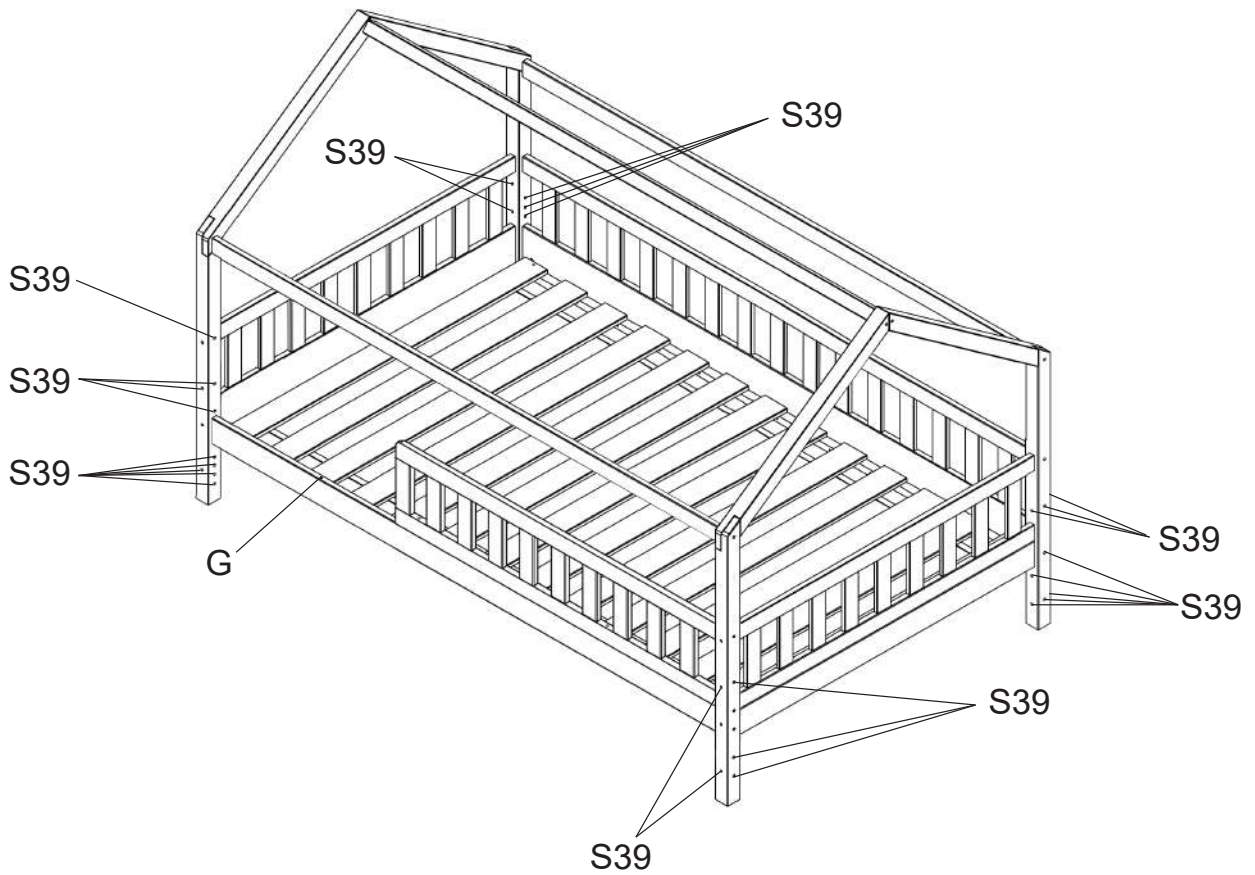

# 9

**R29**



M6x8x15 mm

2x

**P202**



M6x35 mm

2x

## VARIANTE 1 + 2 Montage mit oder ohne Quersterbe

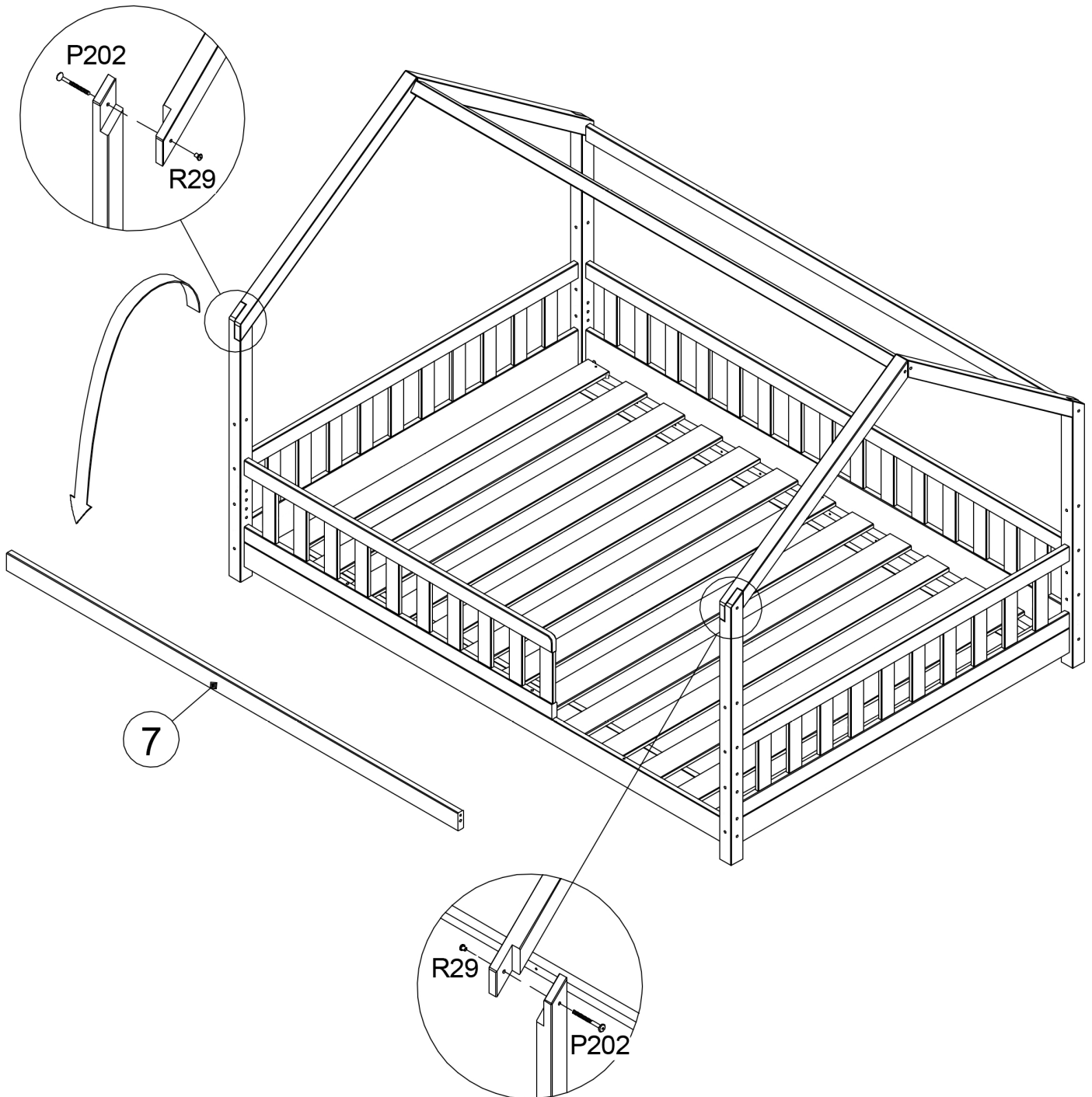

- D Bitte nur mit einem Staubtuch oder leicht feuchtem Lappen reinigen. Keine scheuernden Putzmittel verwenden.
- GB Please only clean with a duster or a damp cloth. Do not use any abrasive cleaners.
- FR Veuillez nettoyer uniquement avec un chiffon à poussière ou un chiffon légèrement humide. Ne pas utiliser de détergent abrasif.
- IT Si raccomanda di pulire solo con un panno per la polvere o uno strofinaccio umido. Non utilizzare detergenti abrasivi.
- NL Reinig alleen met een stofdoek of een lichtjes vochtige doek. Gebruik geen schurende poetsmiddelen.
- PL Czyszczenie należy wykonać wyłącznie za pomocą ściereczki lub lekko nawilżonego ręcznika. Nie stosować środków czyszczących do szorowania.
- CZ Čistěte prosím jen prachovkou nebo lehce navlhčeným hadrem. Nepoužívejte drhnutí čistící prostředky.
- SK Na čistenie používajte len prachovku alebo zľahka navlhčenú utierku. Nepoužívajte žiadne drhúce čistiace prostriedky.
- HU Kérjük, csak portörölő kendővel vagy enyhén nedves ronggyal tisztítsa. Ne használjon dörzsható tisztítószert.
- RO Vă rugăm să utilizați la curățare exclusiv o cârpă de șters praful sau o cârpă ușor umezită. Nu utilizați substanțe de curățat abrazive.
- TR Lütfen sadece bir toz bezyle veya hafif nemli yumuşak bir bezle siliniz. Aşındırıcı temizlik malzemeleri kullanmayınız.
- RU Очищайте от пыли тряпкой или слегка влажной ветошью. Не допускается применение чистящих средств, не предназначенных для ухода за мебелью.