

MONTAGEANLEITUNG

Artikelnummer: N622P166148
N622P166158
N622P166159

Dieses Set ist in 3 Boxen enthalten. Wenn Sie keine vollen 3 Boxen erhalten wenden Sie sich bitte an unseren Kundenservice.

This set comes in 3 boxes. If you do not receive a full 3 boxes, please contact our customer service.

Etagenbett 200x90cm

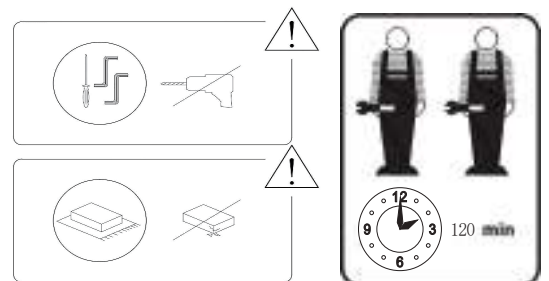
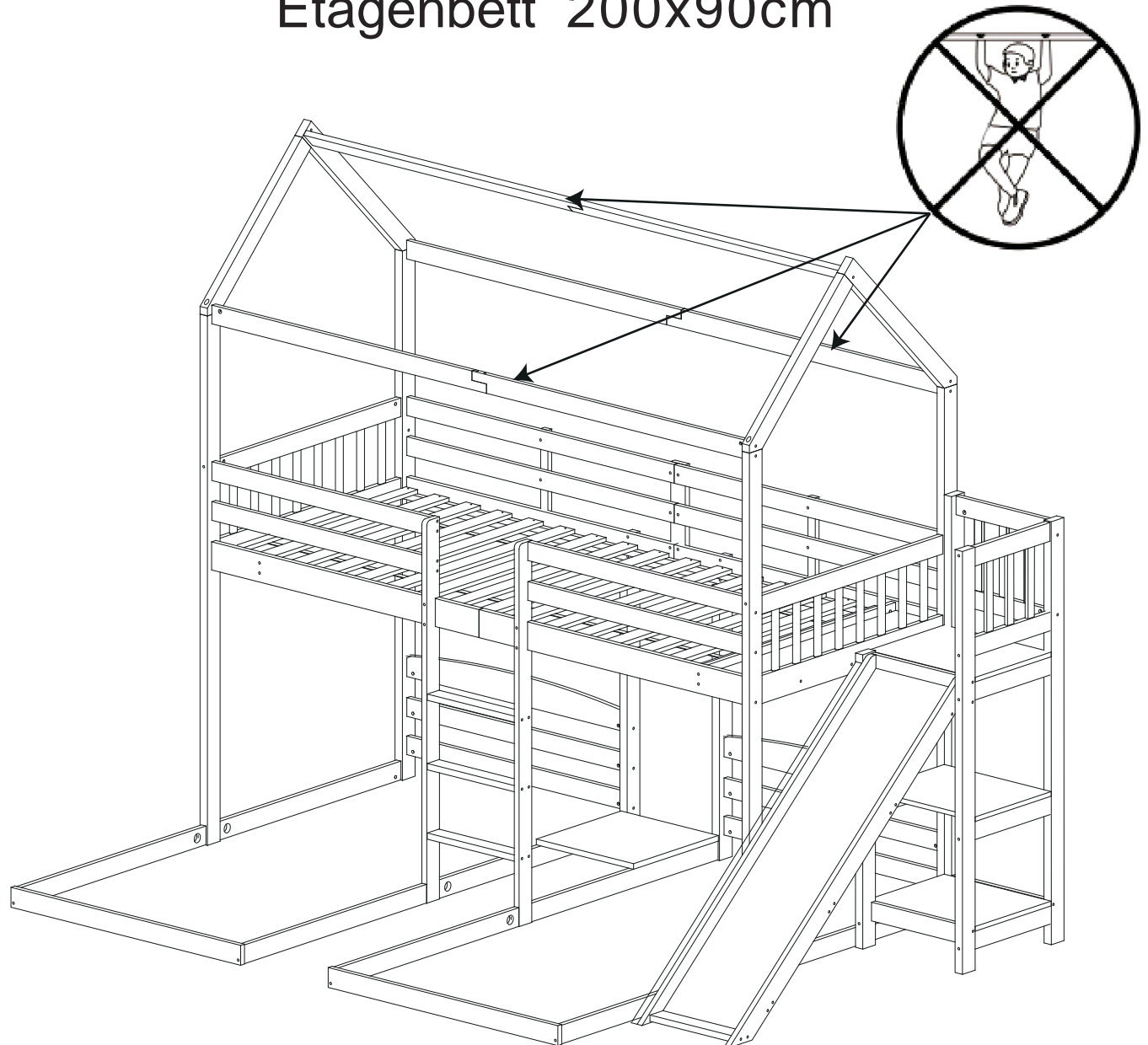

INSTRUCTIONS

IMPORTANT-READ CAREFULLY-RETAIN FOR FUTURE REFERENCE

- a) **WARNING**-High beds and the upper bed of bunk beds are not suitable for children under six years due to the risk of injury from falls;
- b) **WARNING**-Bunk beds and high beds can present a serious risk of injury from strangulation if not used correctly. Never attach or hang items to any part of the bunk bed that are not designed to be used with the bed, for example, but not limited to ropes, strings, cords, hooks, belts and bags.
- c) **WARNING** -Children can become trapped between the bed and the wall, a roof pitch, the ceiling adjoining pieces of furniture (e.g. cupboards) and the like. To avoid risk of serious injury the distance between the top safety barrier and the adjoining structure shall not exceed 75 mm or shall be more than 230 mm.
- d) **WARNING**-Do not use the bunk bed/high bed if any structural part is broken or missing; Replacement parts are between requested from the manufacturer or the store.
- e) it is imperative to always follow the installation instructions and manufacturer's use.
- f) The recommended size of the mattress to be used with the bed is 200*90cm maximum thickness mattress: **13**cm.
- g) It is necessary to ventilate the room in order to maintain a low level moisture and prevent mold growth in the bed and its periphery.
- h) Joining devices should always be tightened properly and regularly verified. Tighten if necessary.

ANLEITUNG

WICHTIG-SORGFÄLTIG DURCHLESEN-FÜR ZUKÜNFTIGE REFERENZ BEWAHREN

- a) **WARNUNG** -Das Oberbett von Etagenbett ist wegen der Verletzungsgefahr durch Stürze nicht für Kinder unter sechs Jahren geeignet.
- b) **WARNUNG** -Etagenbetten und Hochbetten können ein ernstes Verletzungsrisiko darstellen, wenn sie nicht ordnungsgemäß verwendet werden. Befestigen oder hängen Sie niemals etwas an einem Teil des Etagenbettes, das nicht für das Bett bestimmt ist, wie z. B. Seile, Haken, Gurte und Taschen.
- c) **WARNUNG** -Kinder können zwischen Bett und Wand eingeklemmt werden. Um die Gefahr schwerer Verletzungen zu vermeiden, darf der Abstand zwischen der oberen Sicherheitsbarriere und der angrenzenden Konstruktion 75 mm nicht überschreiten oder mehr als 230 mm betragen.
- d) **WARNUNG** -Verwenden Sie das Etagenbett/Hochbett nicht, wenn ein Bauteil beschädigt ist oder fehlt. Ersatzteile werden zwischendurch beim Hersteller oder beim Händler angefordert.
- e) Befolgen Sie unbedingt die Installationsanweisungen und die Gebrauchsanweisung des Herstellers.
- f) Die empfohlene Größe der Matratze für das Bett beträgt 200*90cm maximale Dicke der Matratze: **13** cm.
- g) Es ist notwendig, den Raum zu lüften, um ein niedriges Feuchtigkeitsniveau aufrechtzuerhalten und das Wachstum von Schimmel im Bett und an dessen Peripherie zu verhindern.
- h) Verbindungselemente sollten immer richtig angezogen und regelmäßig überprüft werden. Bei Bedarf festziehen.

Stückliste-1

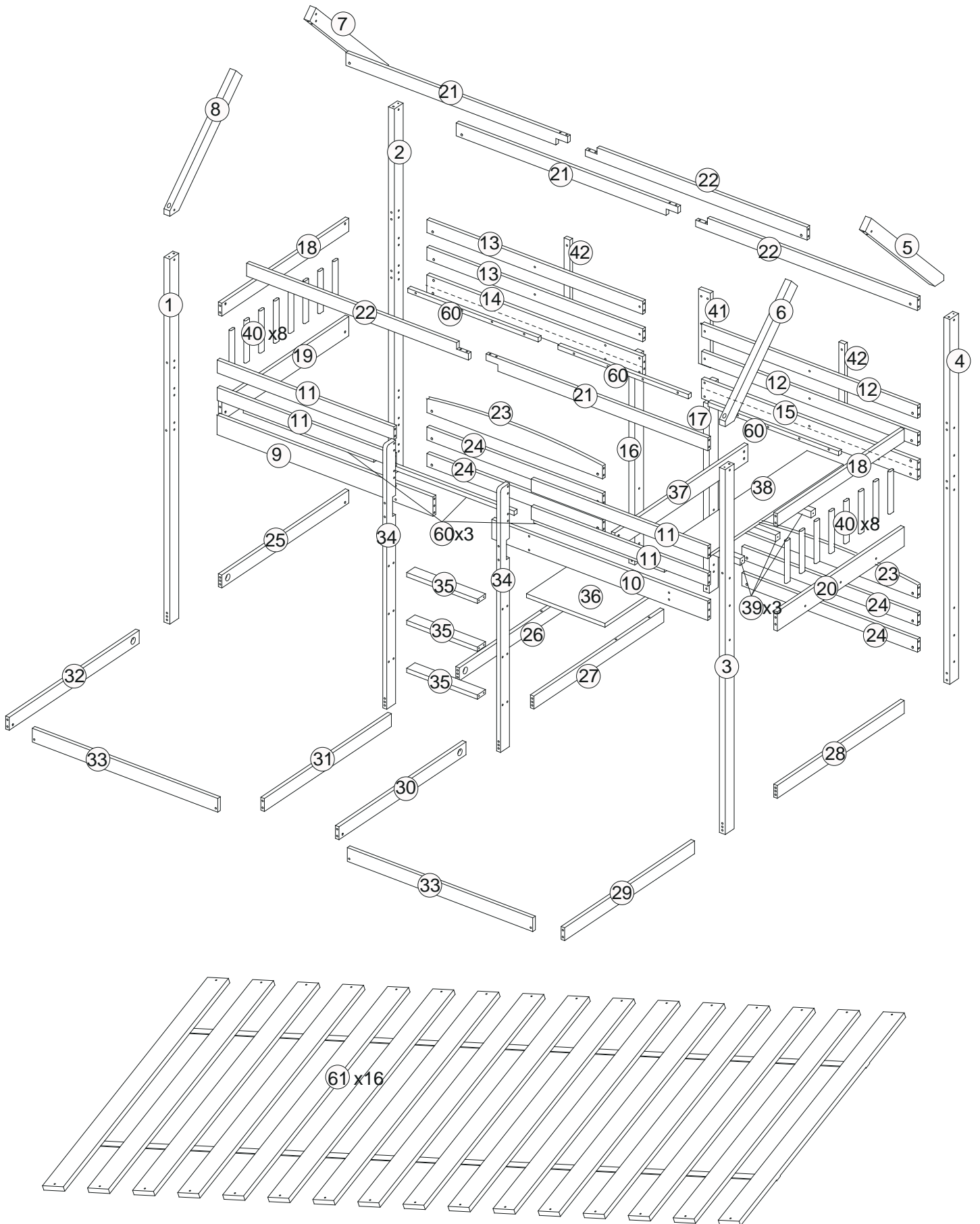

Stückliste-2

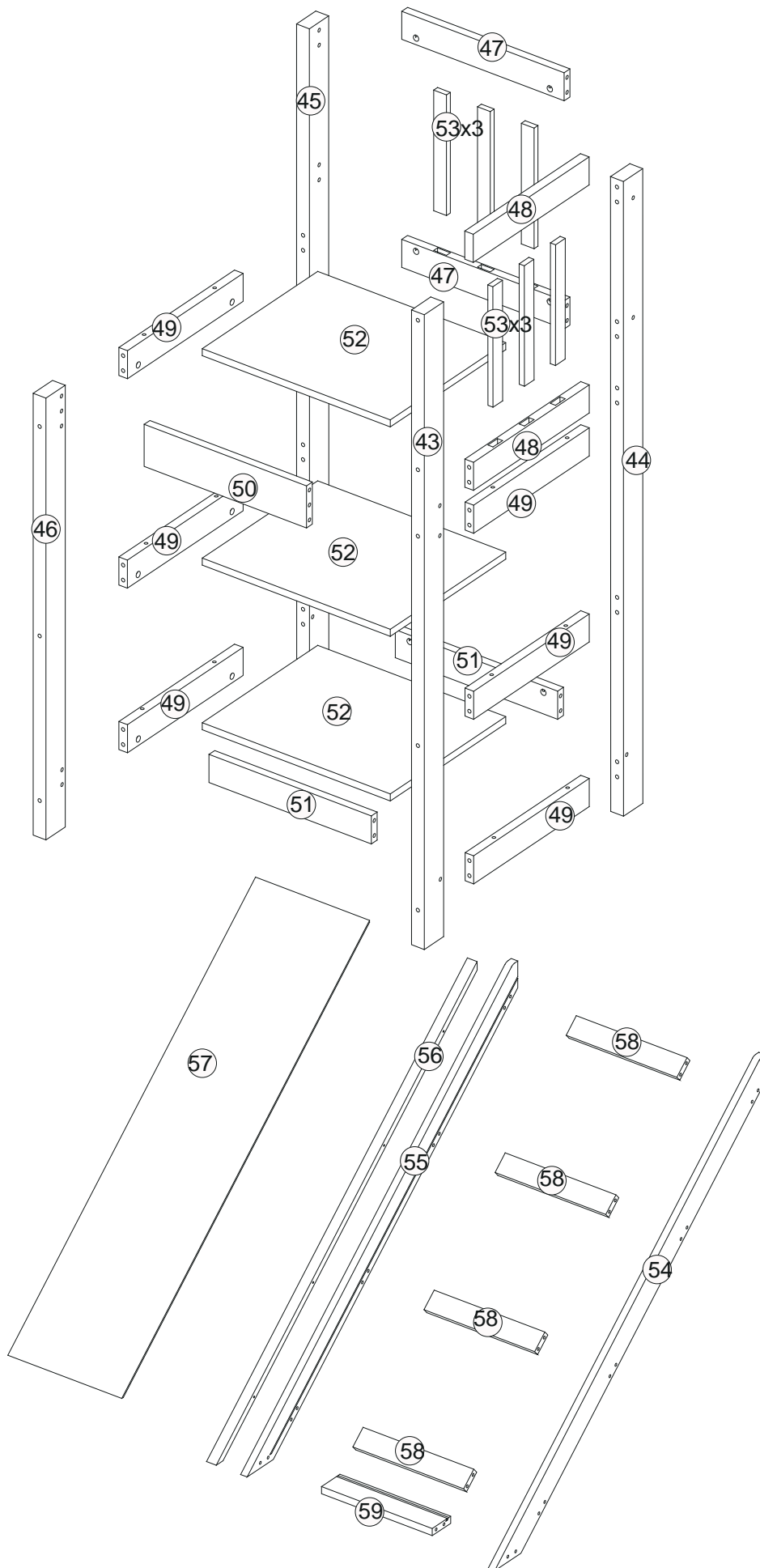







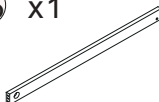
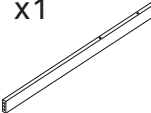
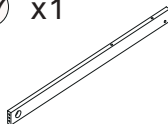
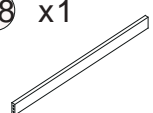
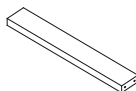

Part List N622P166148

| | | | | |
|----------|----------|----------|----------|----------|
| ① x1 | ② x1 | ③ x1 | ④ x1 | ⑤ x1 |
| ⑥ x1 | ⑦ x1 | ⑧ x1 | ⑨ x1 | ⑩ x1 |
| ⑭ x1 | ⑮ x1 | ⑯ x1 | ⑰ x1 | ⑳ x3 |
| ㉒ x3 | ㉔ x2 | ㉗ x1 | ㉘ x1 | ㉙ x1 |
| ㉛ x1 | ㉜ x1 | ㉞ x1 | ㉟ x1 | |



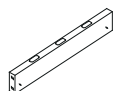
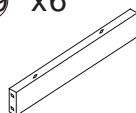
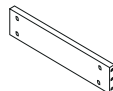
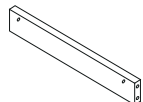

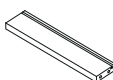





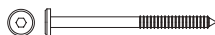

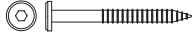
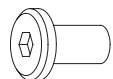

Part List N622P166158

| | | | | |
|-----------|-----------|-----------|------------|-----------|
| ⑫ x2 | ⑬ x2 | ⑱ x2 | ⑲ x1 | ⑳ x1 |
| ㉓ x2 | ㉔ x4 | ㉙ x1 | ⑳ x1 | ㉚ x1 |
| ㉛ x1 | ㉜ x2 | ㉞ x1 | ㉟ x1 | ㉚ x1 |
| ④⑥ x1 | ⑤② x3 | ③⑨ x3 | ④① x16 | ⑤③ x6 |

Part List N622P166159

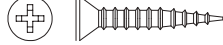
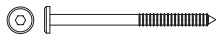
| | | | | |
|--|---|--|---|--|
| ①① x4  | ②⑤ x1  | ②⑥ x1  | ②⑦ x1  | ②⑧ x1  |
| ③⑤ x3  | ④① x1  | ④② x2  | ④⑦ x2  | ④⑧ x2  |
| ④⑨ x6  | ⑤① x1  | ⑤① x2  | ⑤⑧ x4  | ⑤⑨ x1  |
| ⑥① x6  | ⑥① x16  | | | |

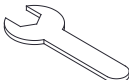
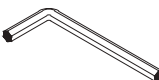
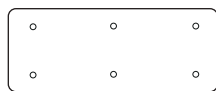
Hardware List N622P166158

| | | | | |
|---|---|--|---|---|
| A x106  Φ8x30 | B x46  M6x80 | C x84  | D x46  Φ6x60 | E x30  |
| F x18  M6x30 | G x10  | H x30  M6x100 | I x4  Φ8 | J x69  Φ4x30 |
| K x5  M6x140 | L x12  M6x50 | M x17  Φ4x40 | N x8  M6x60 | O x6  Φ3.5x16 |
| P x2  | Q x1  | R x1  | S x2  | T x12  Φ3.5x15 |

Schritt 1

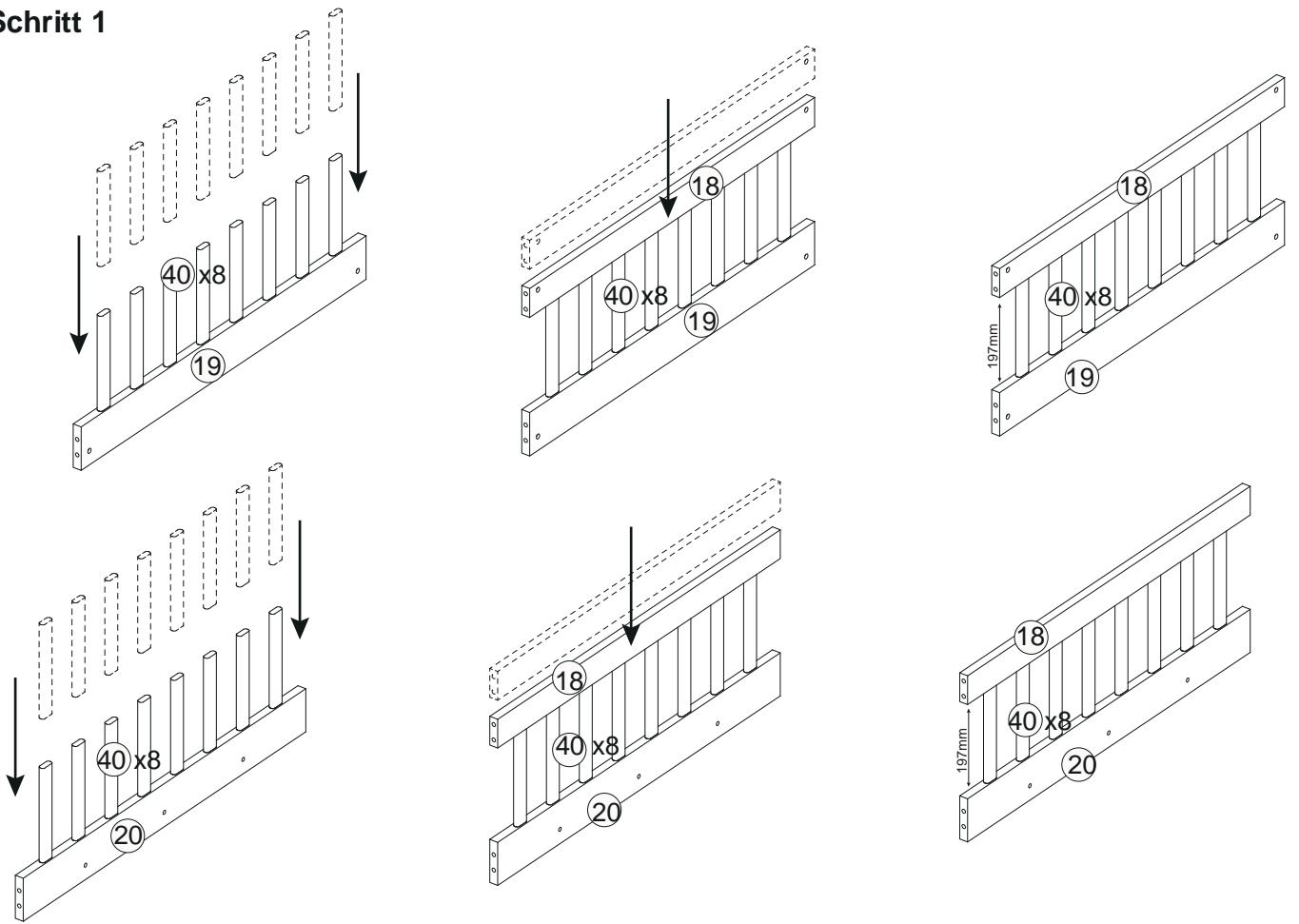

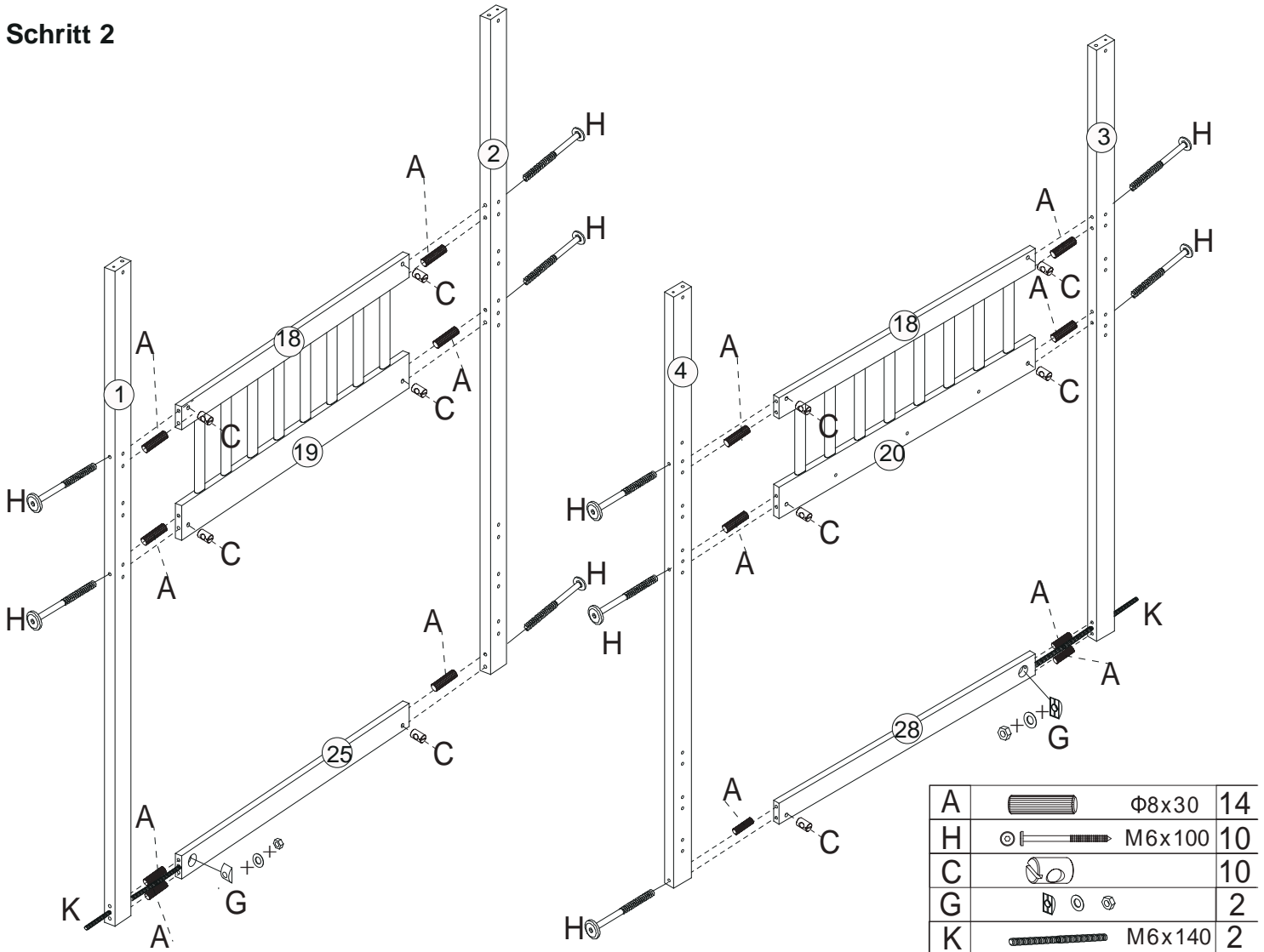

Schritt 2



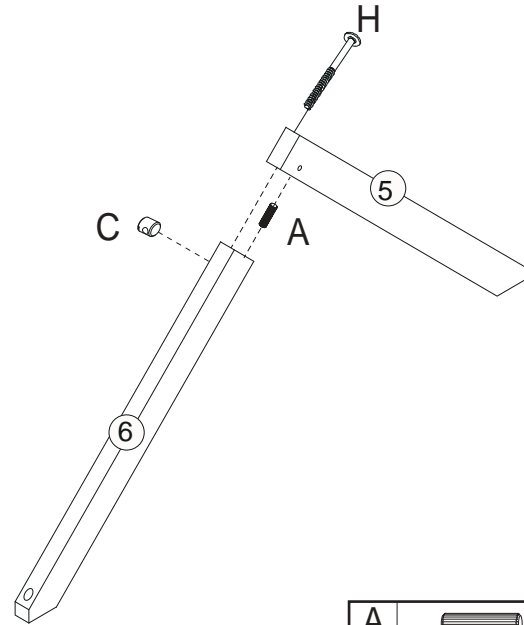
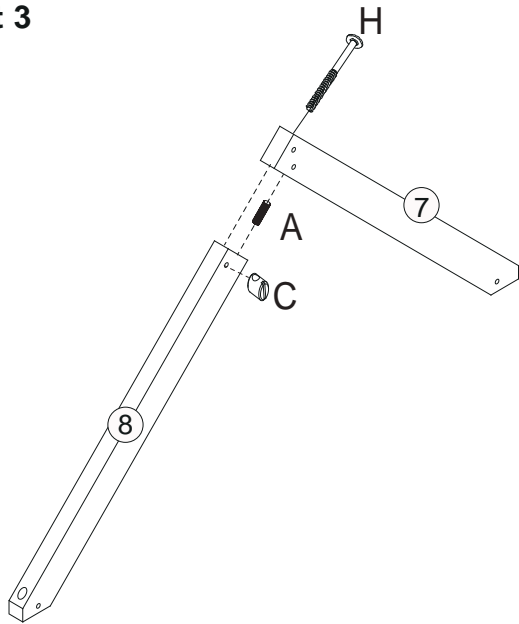

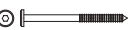
Schritt 3



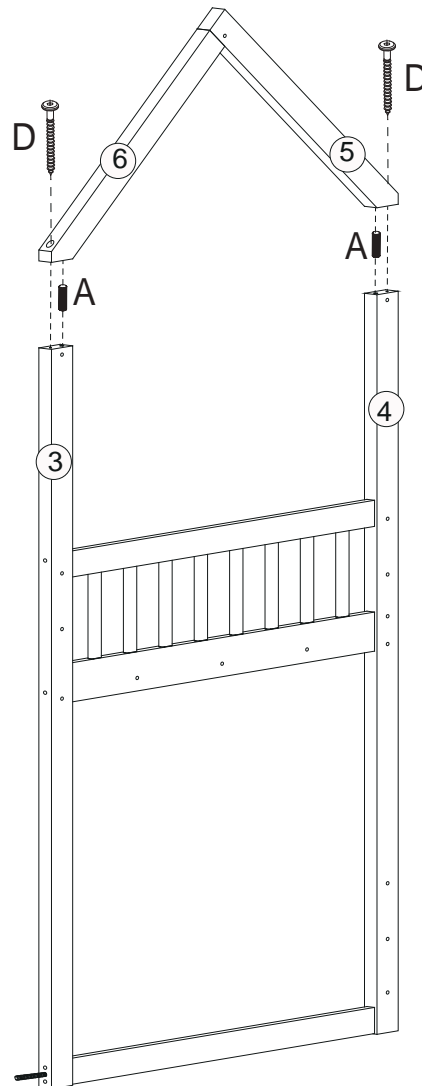
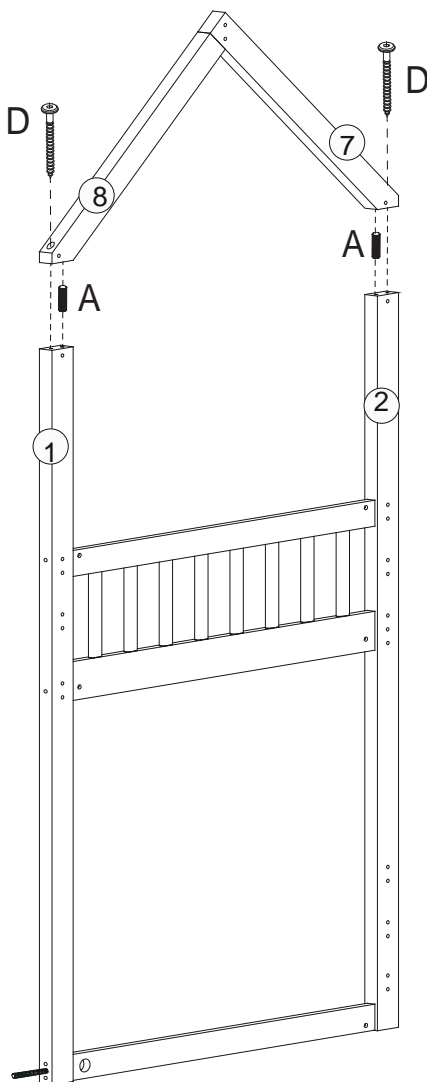

| | | | |
|---|---|--------|---|
| A |  | Φ8x30 | 2 |
| H |  | M6x100 | 2 |
| C |  | | 2 |

Schritt 4





| | | | |
|---|---|-------|---|
| A |  | Φ8x30 | 4 |
| D |  | Φ6x60 | 4 |

Schritt 5

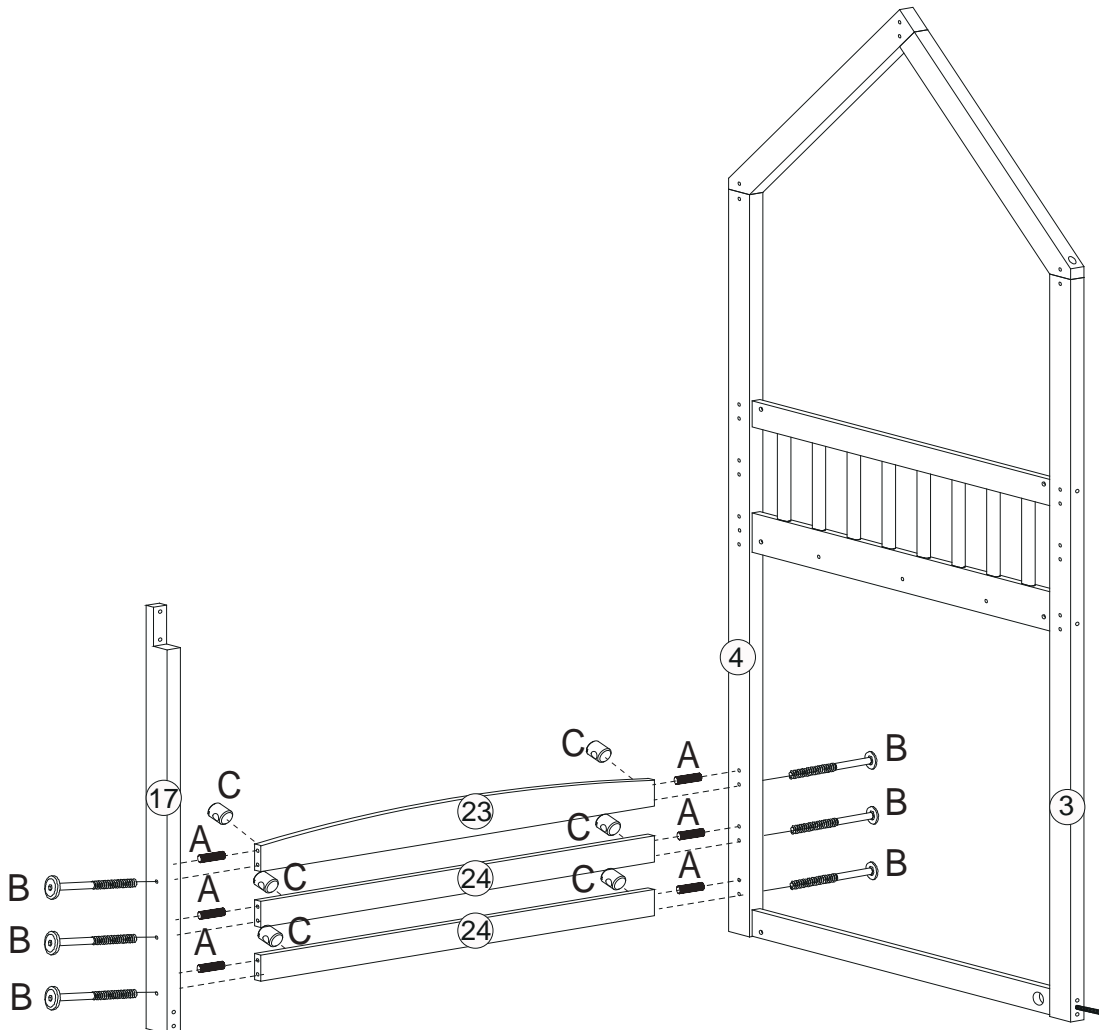
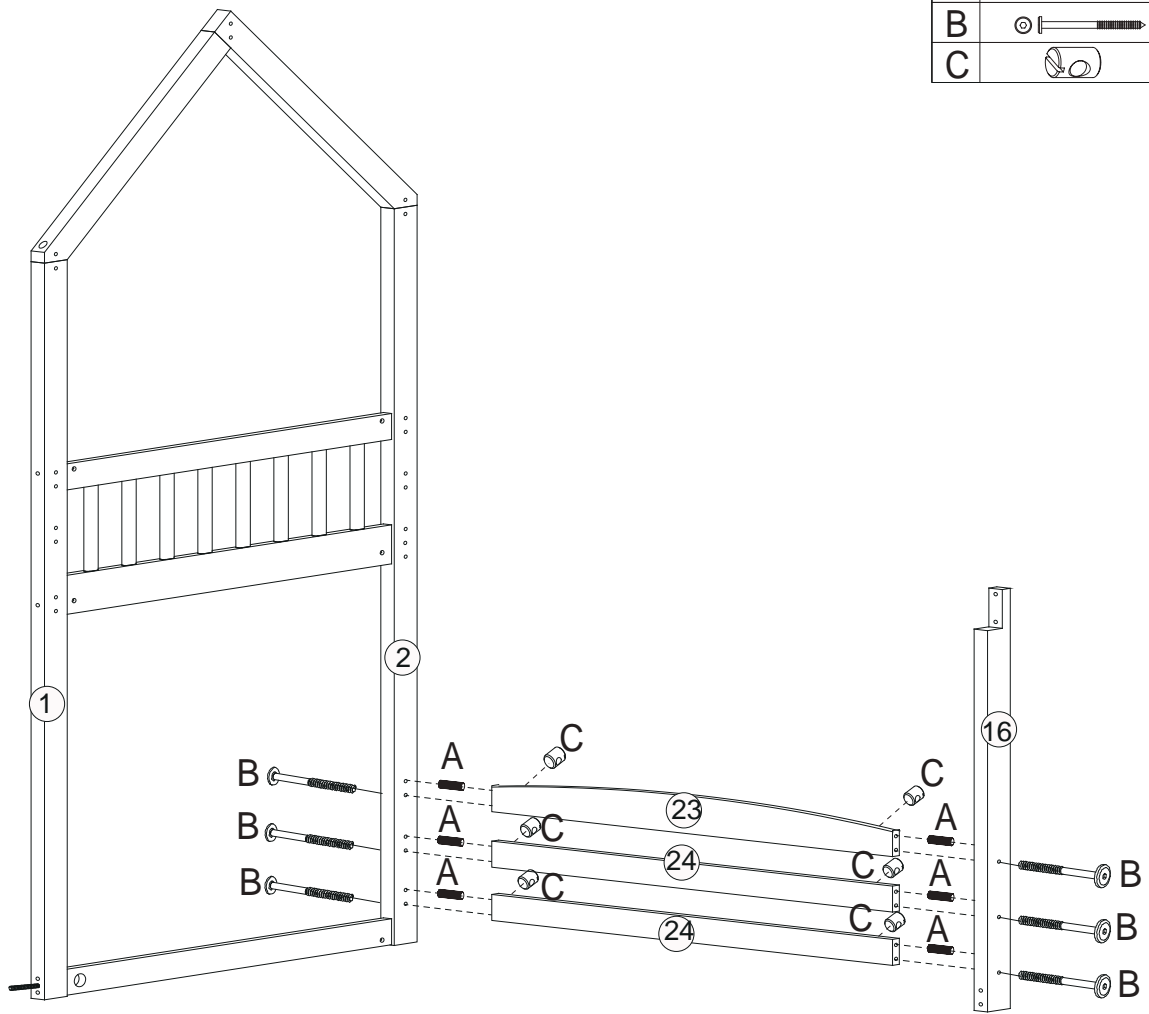
| | | | |
|---|---|-------|----|
| A |  | Φ8x30 | 12 |
| B |  | M6x80 | 12 |
| C |  | | 12 |



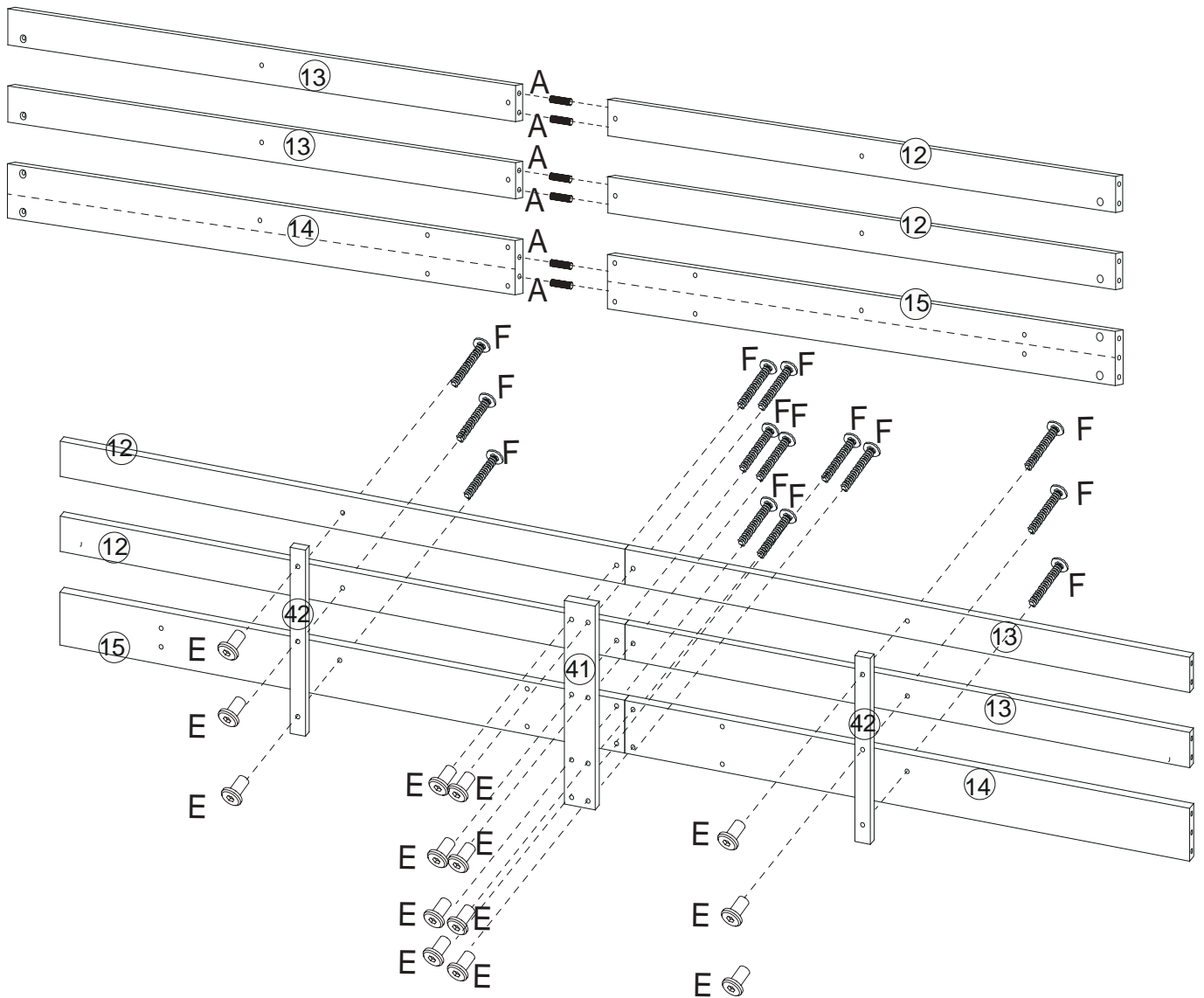

Schritt 6

| | | | |
|---|---|-------|----|
| A |  | Φ8x30 | 6 |
| F |  | M6x30 | 14 |
| E |  | | 14 |





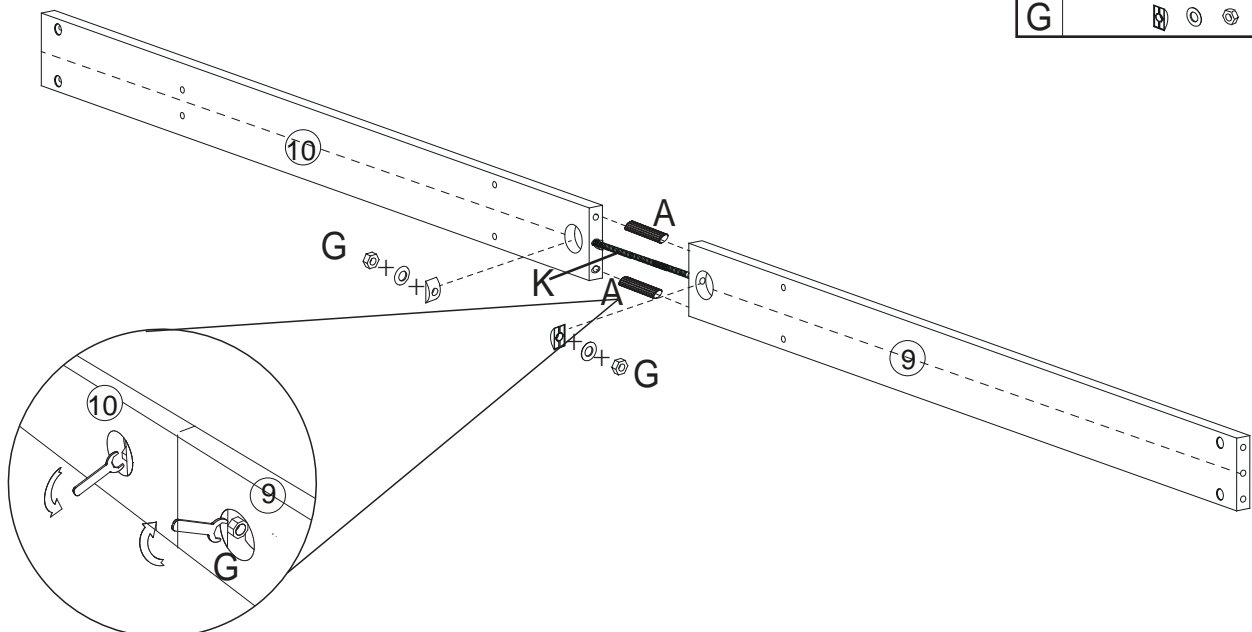

Schritt 7

| | | | |
|---|---|--------|---|
| A |  | Φ8x30 | 2 |
| K |  | M6x140 | 1 |
| G |  | | 2 |



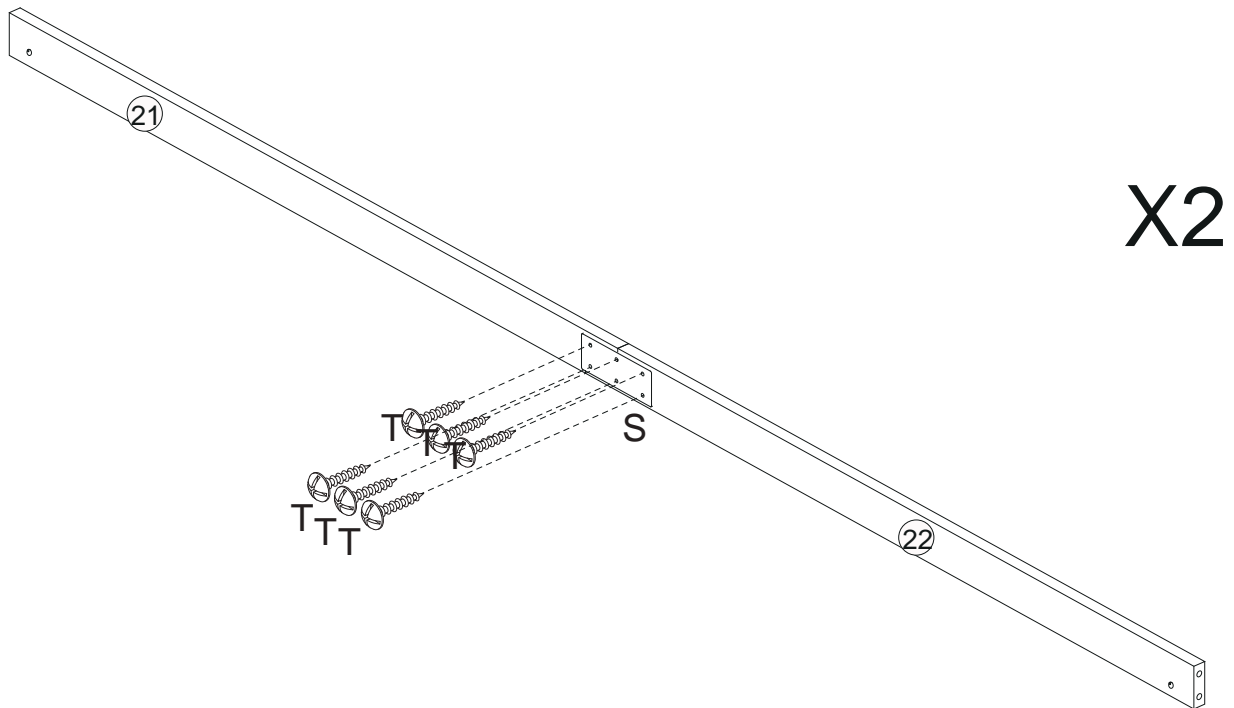
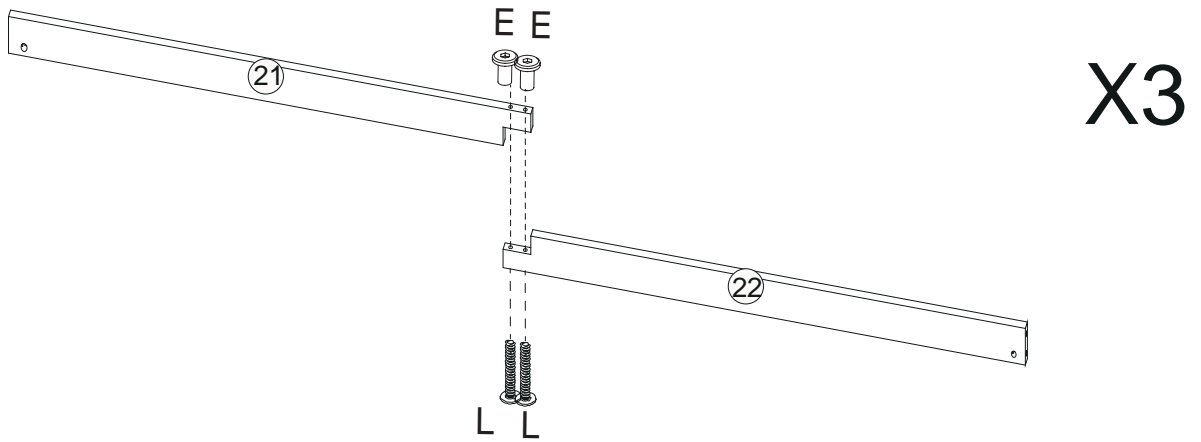

Schritt 8

| | | | |
|---|---|---------|----|
| L |  | M6x50 | 6 |
| E |  | | 6 |
| S |  | | 2 |
| T |  | Φ3.5x15 | 12 |



Oder Sie können S und T auf der anderen Seite befestigen.

Schritt 9

| | | | |
|---|---|-------|----|
| A |  | Φ8x30 | 14 |
| B |  | M6x80 | 18 |
| C |  | | 18 |

Nachdem die Teile Nr. 21 und Nr. 22 mit S
zusammengebaut wurden,
montieren Sie sie hier.

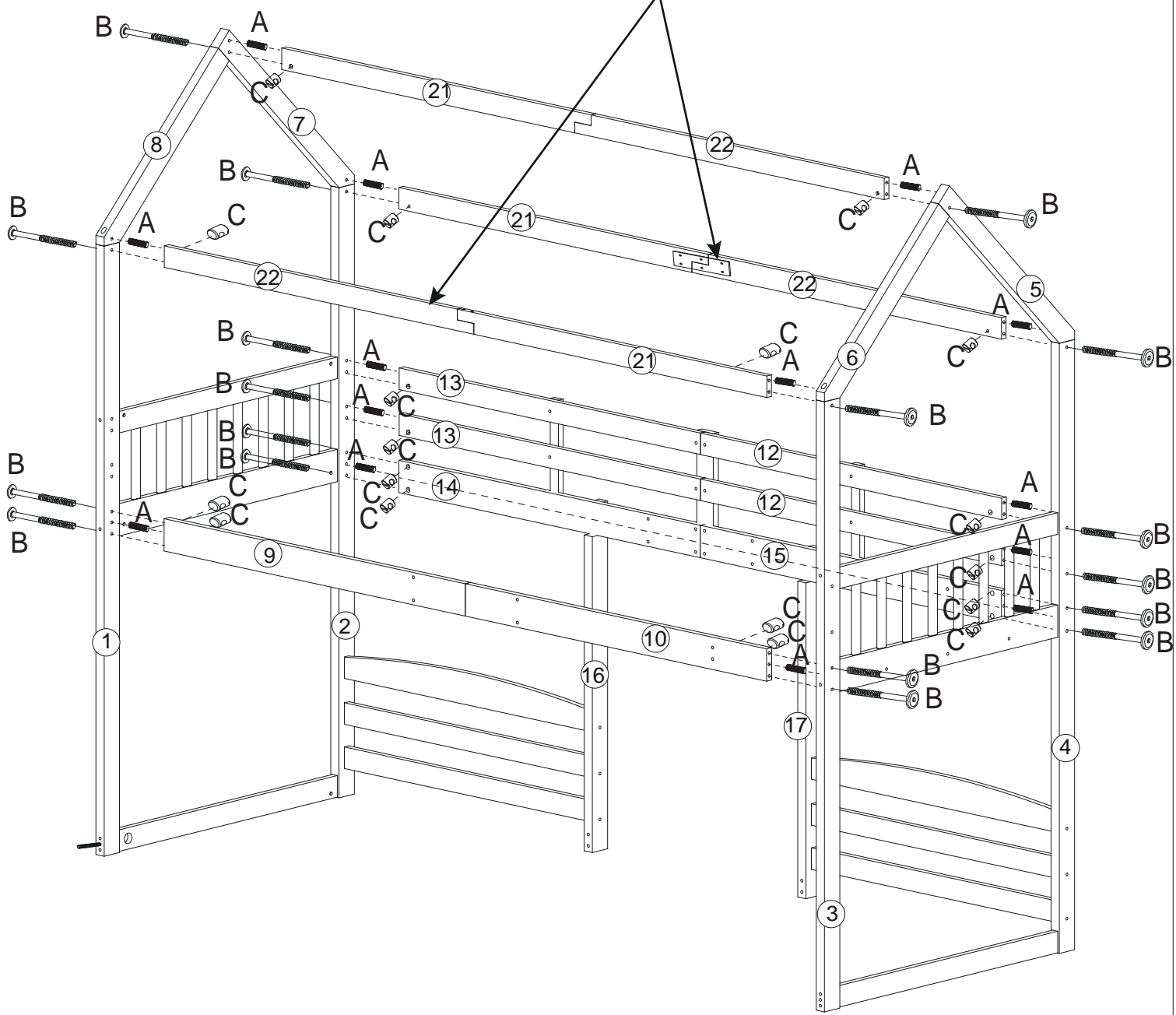

Schritt 10

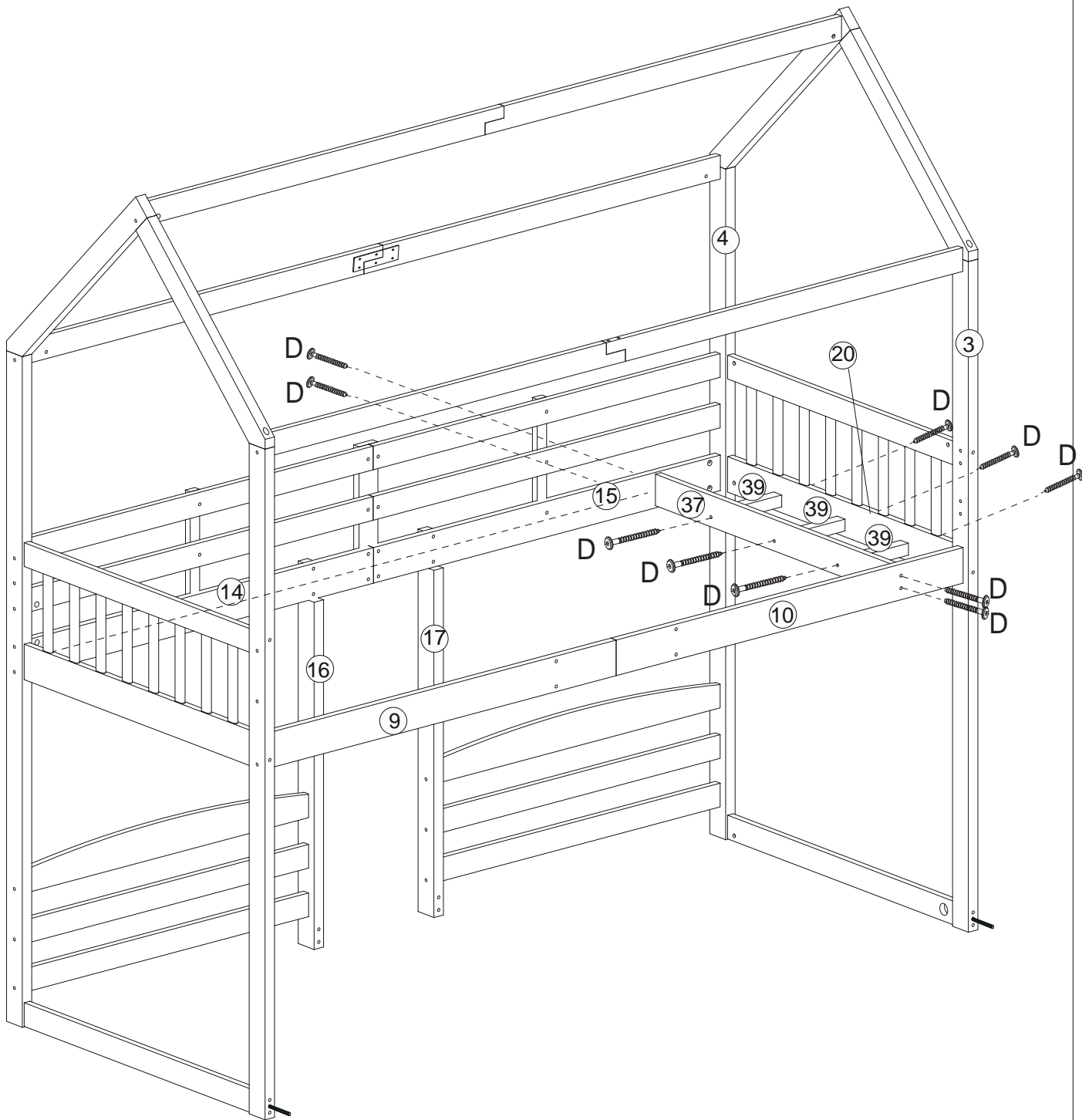

Schritt 11

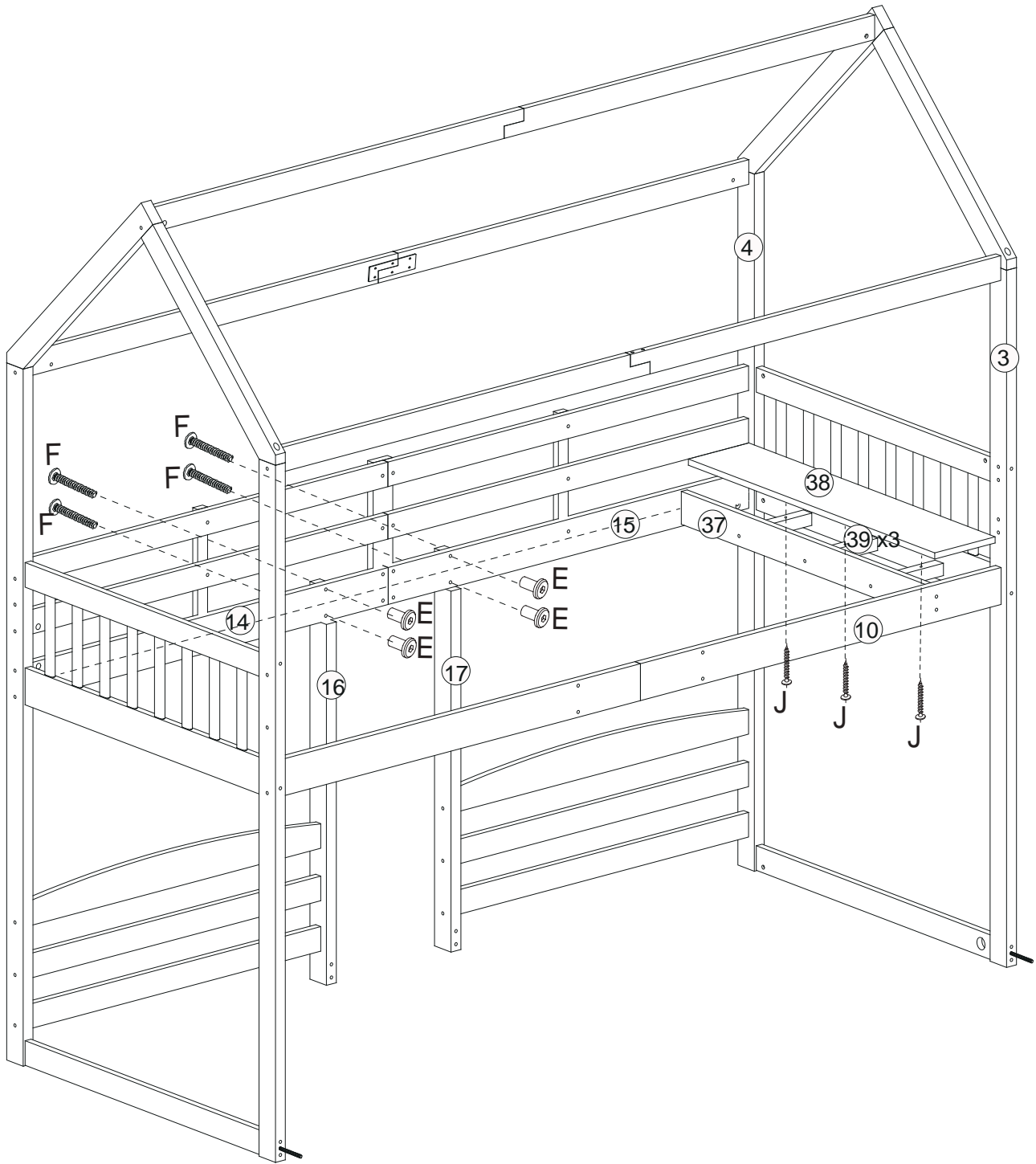



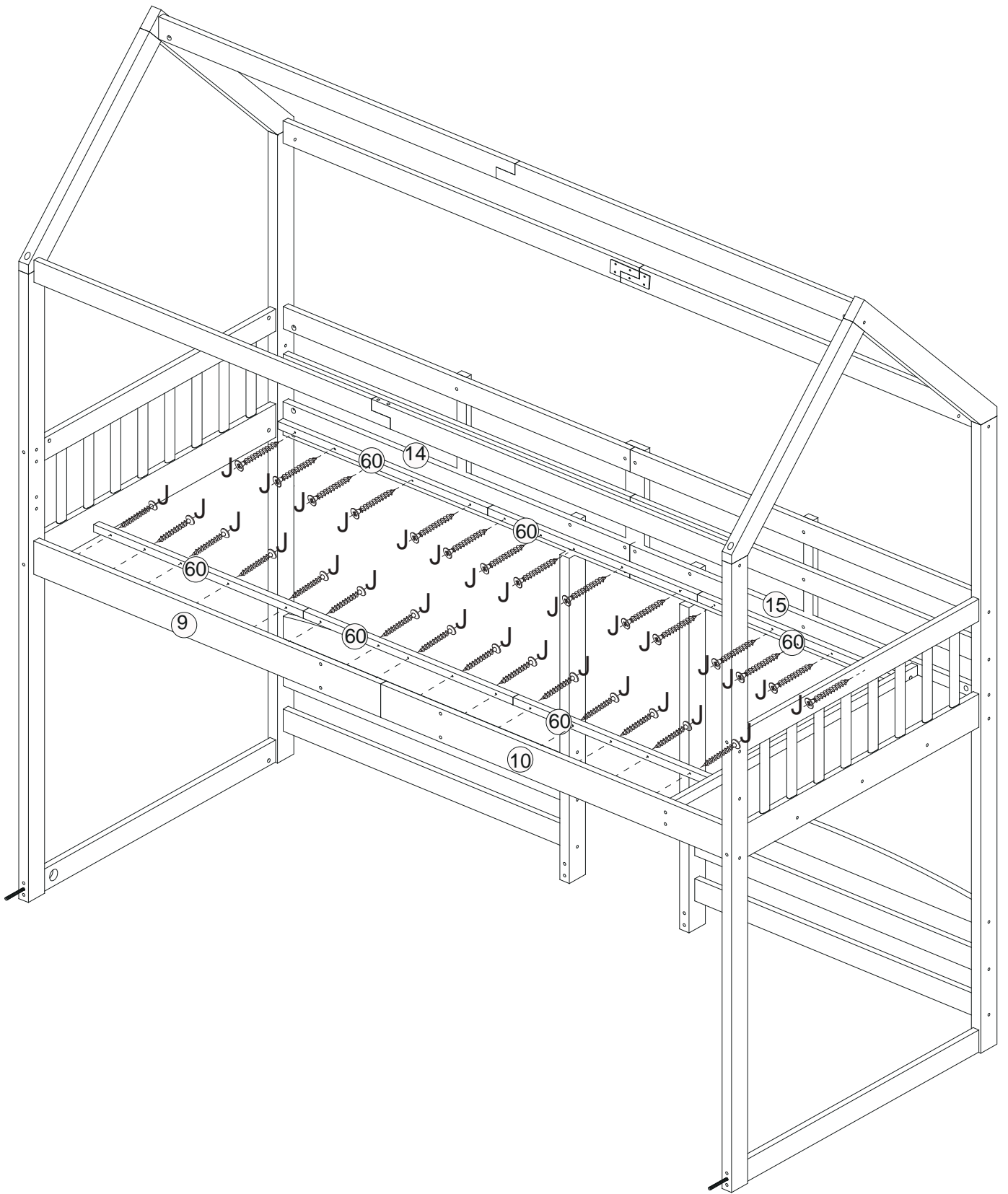

| | | | |
|---|---|-------|---|
| F |  | M6x30 | 4 |
| E |  | | 4 |
| J |  | Φ4x30 | 3 |

Schritt 12

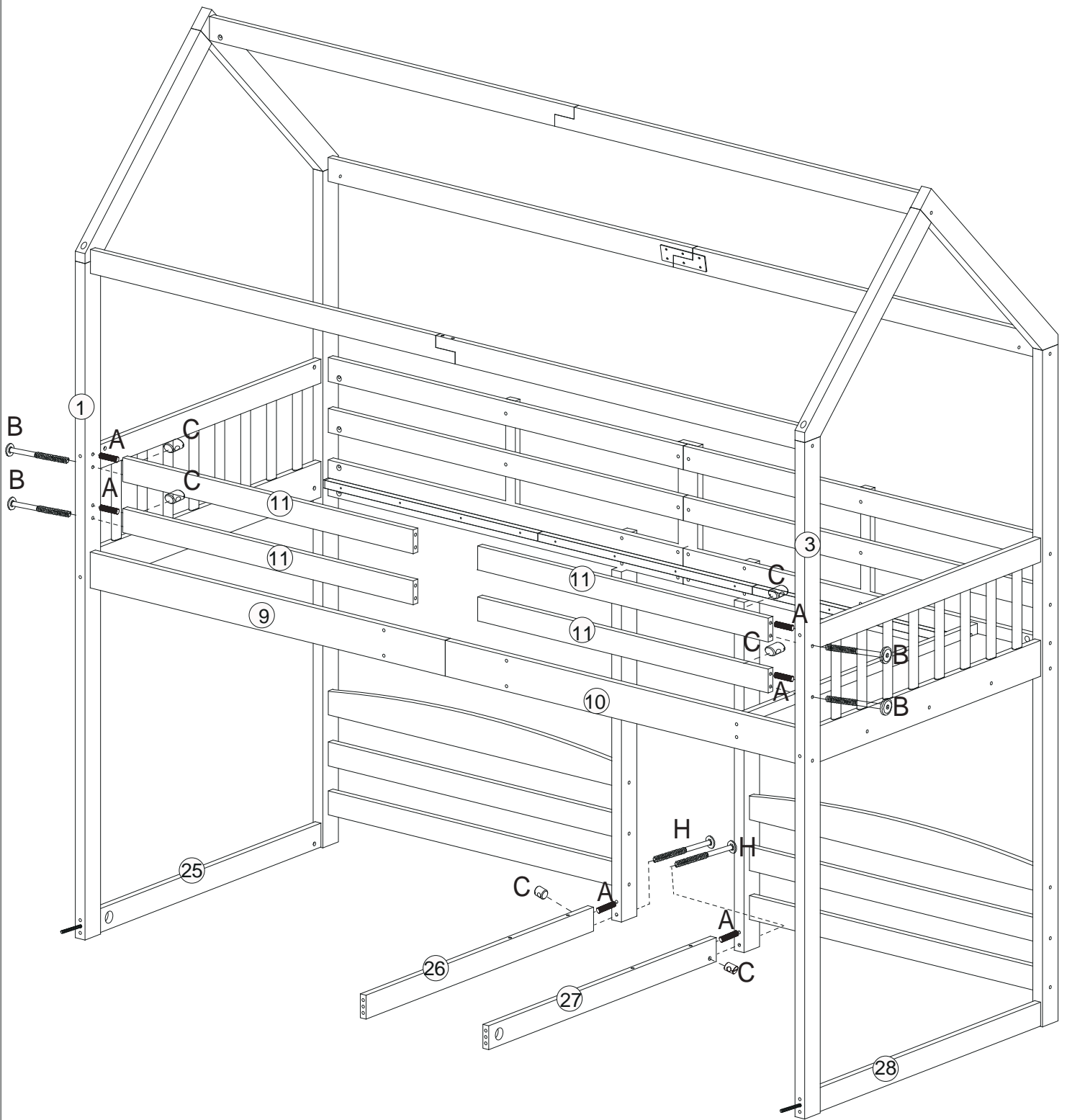

Schritt 13



| | | | |
|---|---|--------|---|
| A |  | Φ8x30 | 6 |
| B |  | M6x80 | 4 |
| C |  | | 6 |
| H |  | M6x100 | 2 |

Schritt 14

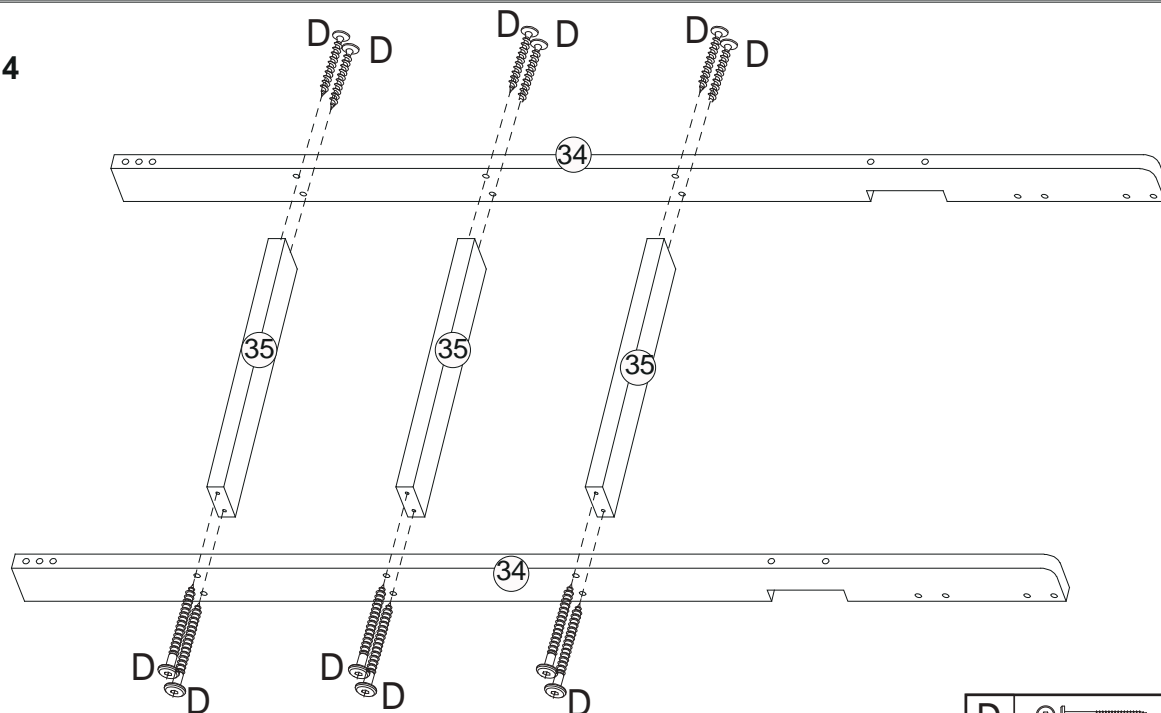



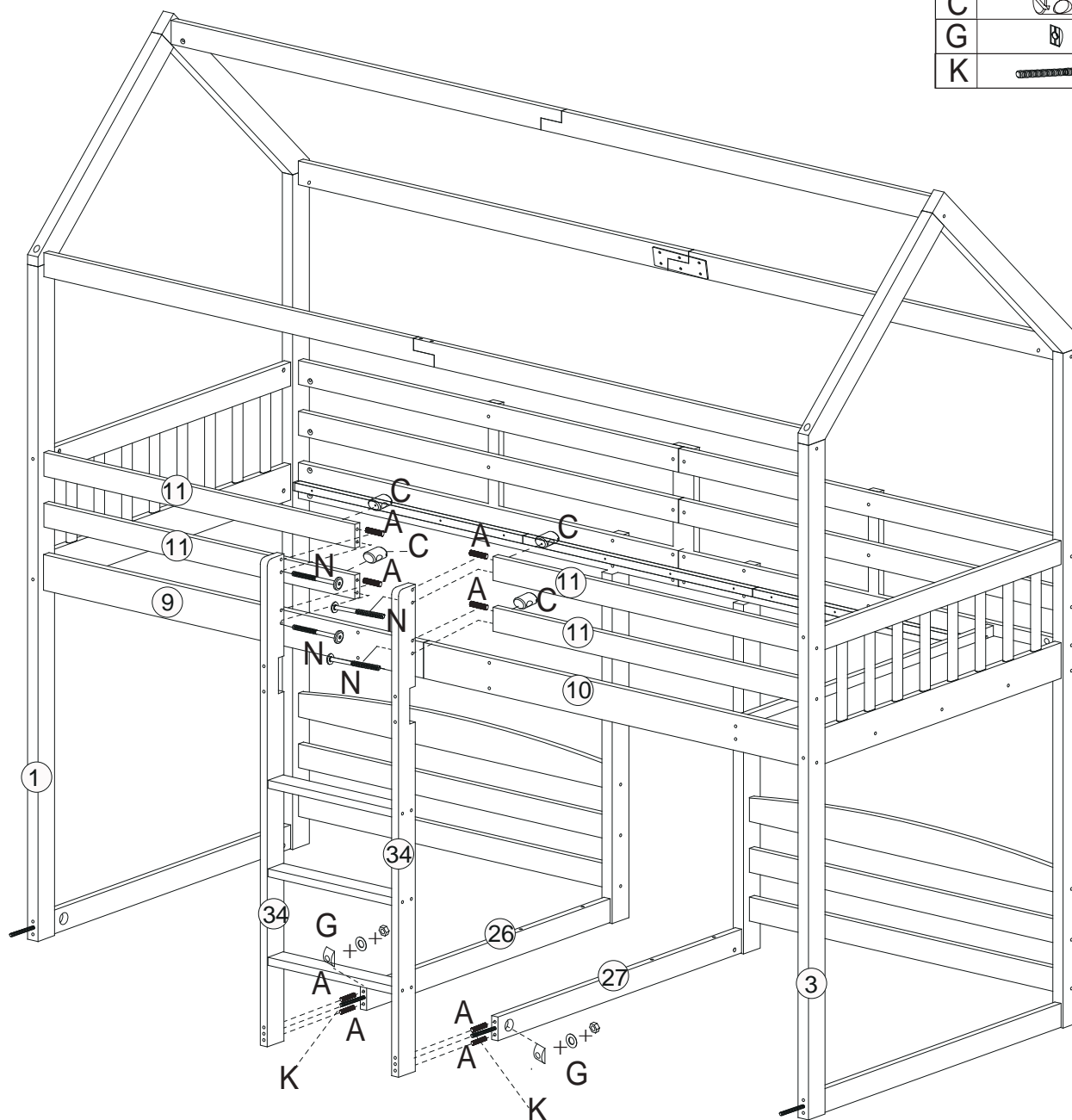

| | | | |
|---|--|--------|----|
| D | | Φ6x60 | 12 |
| A | | Φ8x30 | 8 |
| N | | M6x60 | 4 |
| C | | | 4 |
| G | | | 2 |
| K | | M6x140 | 2 |

Schritt 15

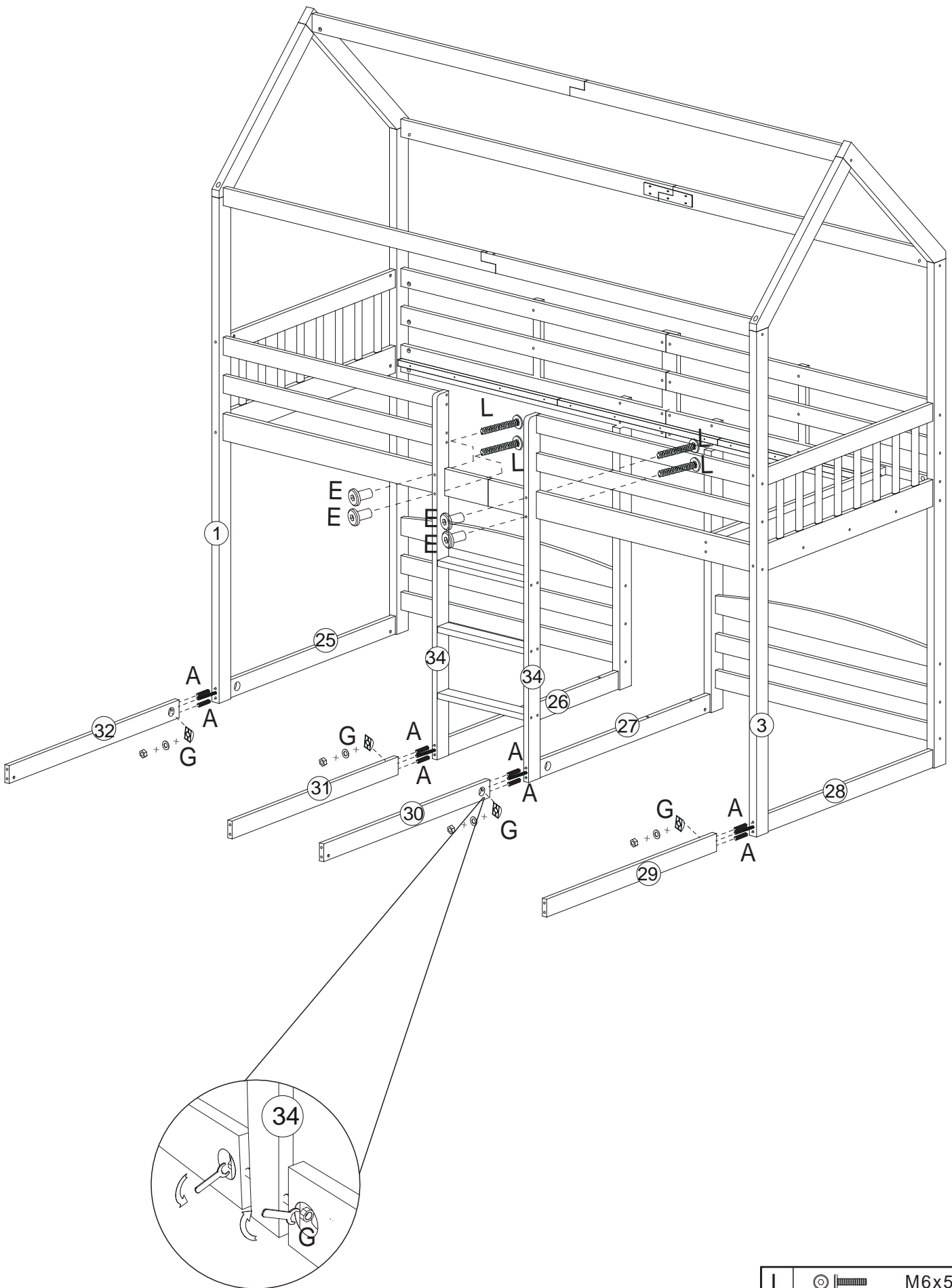





Schritt 16



| | | | |
|---|---|-------|---|
| L |  | M6x50 | 4 |
| E |  | | 4 |
| A |  | Φ8x30 | 8 |
| G |  | | 4 |

Schritt 17

| | | | |
|---|---|-------|---|
| A |  | Φ8x30 | 4 |
| N |  | M6x60 | 4 |
| C |  | | 4 |
| J |  | Φ4x30 | 4 |
| I |  | Φ8 | 4 |

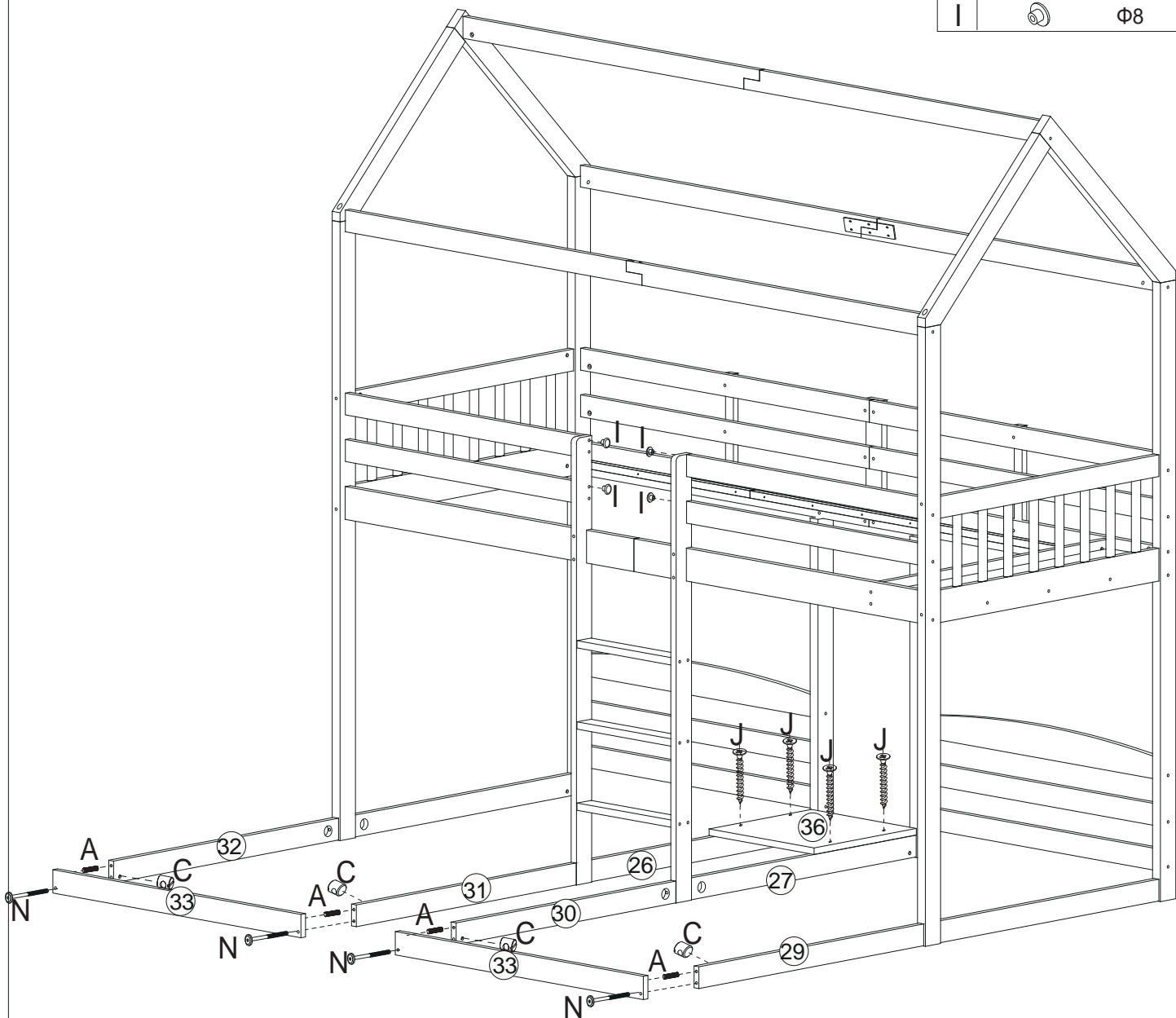

Schritt 18

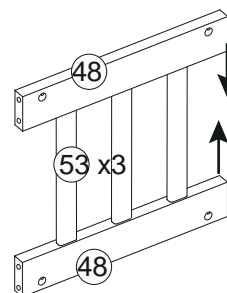
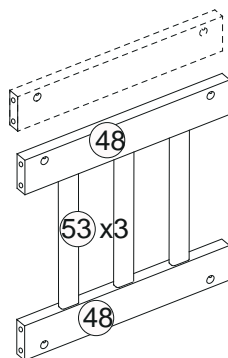
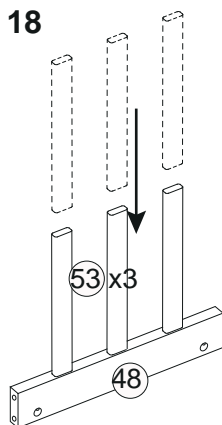

Schritt 19

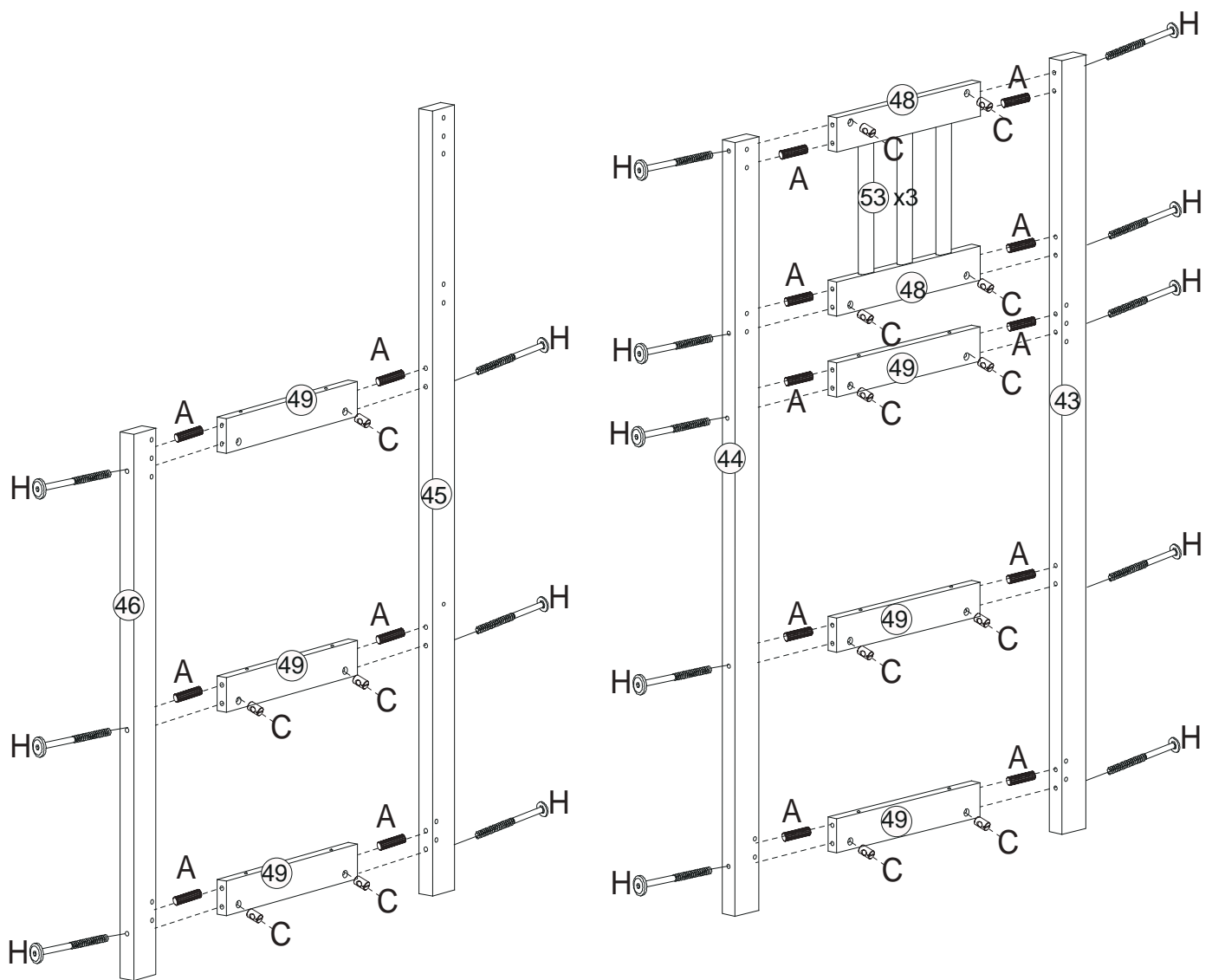

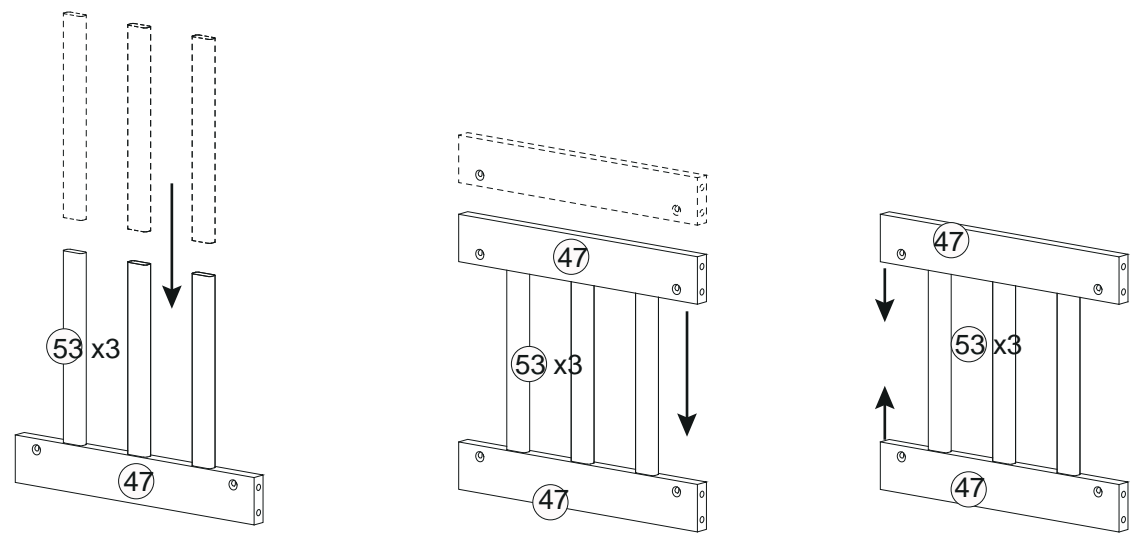

| | | | |
|---|--|--------|----|
| A | | Φ8x30 | 16 |
| H | | M6x100 | 16 |
| C | | | 16 |

Schritt 20



Schritt 21

| | | | |
|---|---|-------|----|
| A |  | Φ8x30 | 10 |
| B |  | M6x80 | 12 |
| C |  | | 12 |

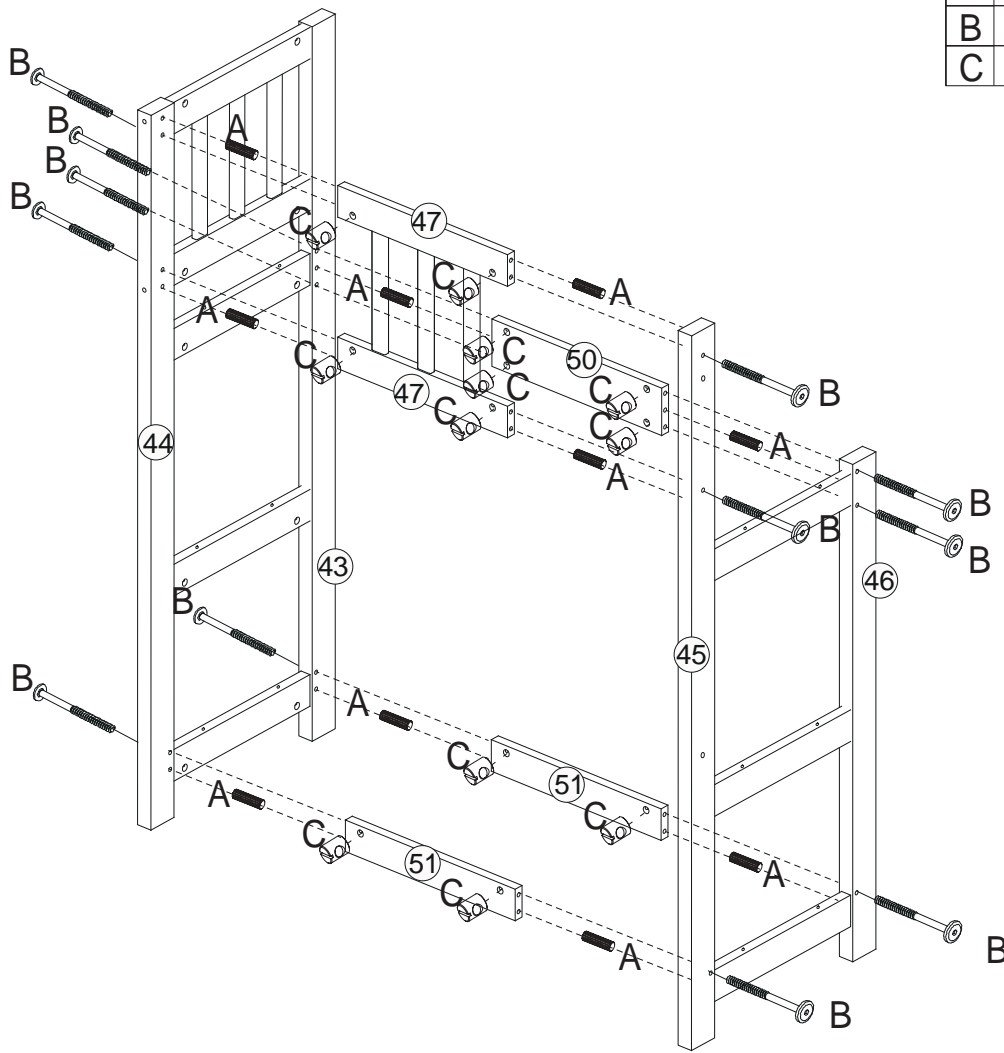

Schritt 22

| | | | |
|---|---|-------|---|
| M |  | Φ4x40 | 8 |
|---|---|-------|---|

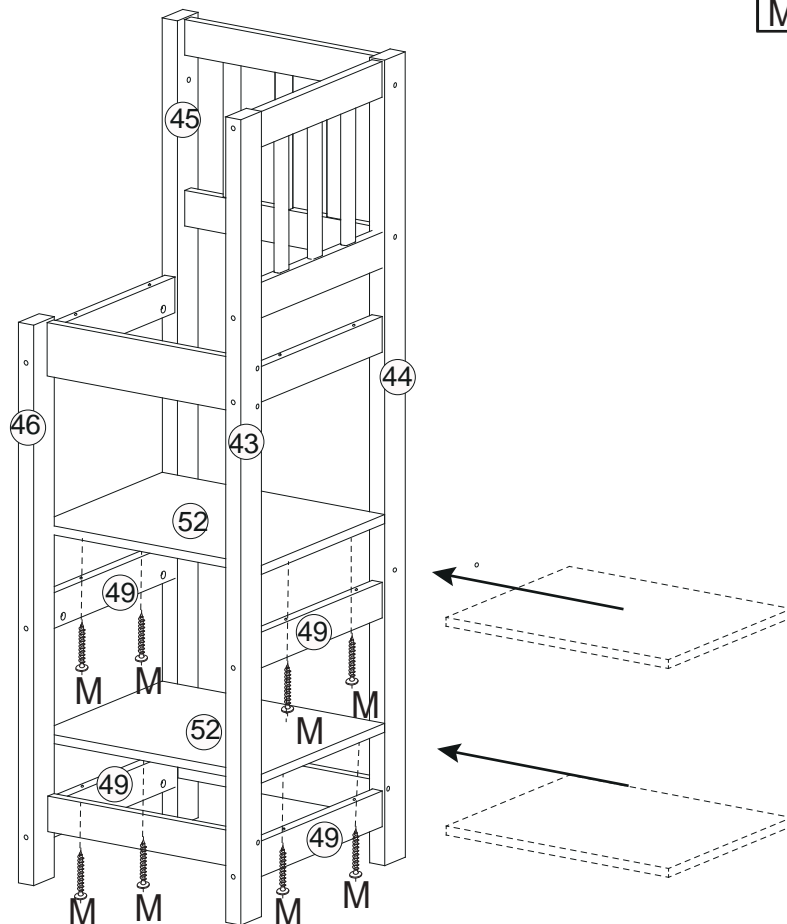

Schritt 23

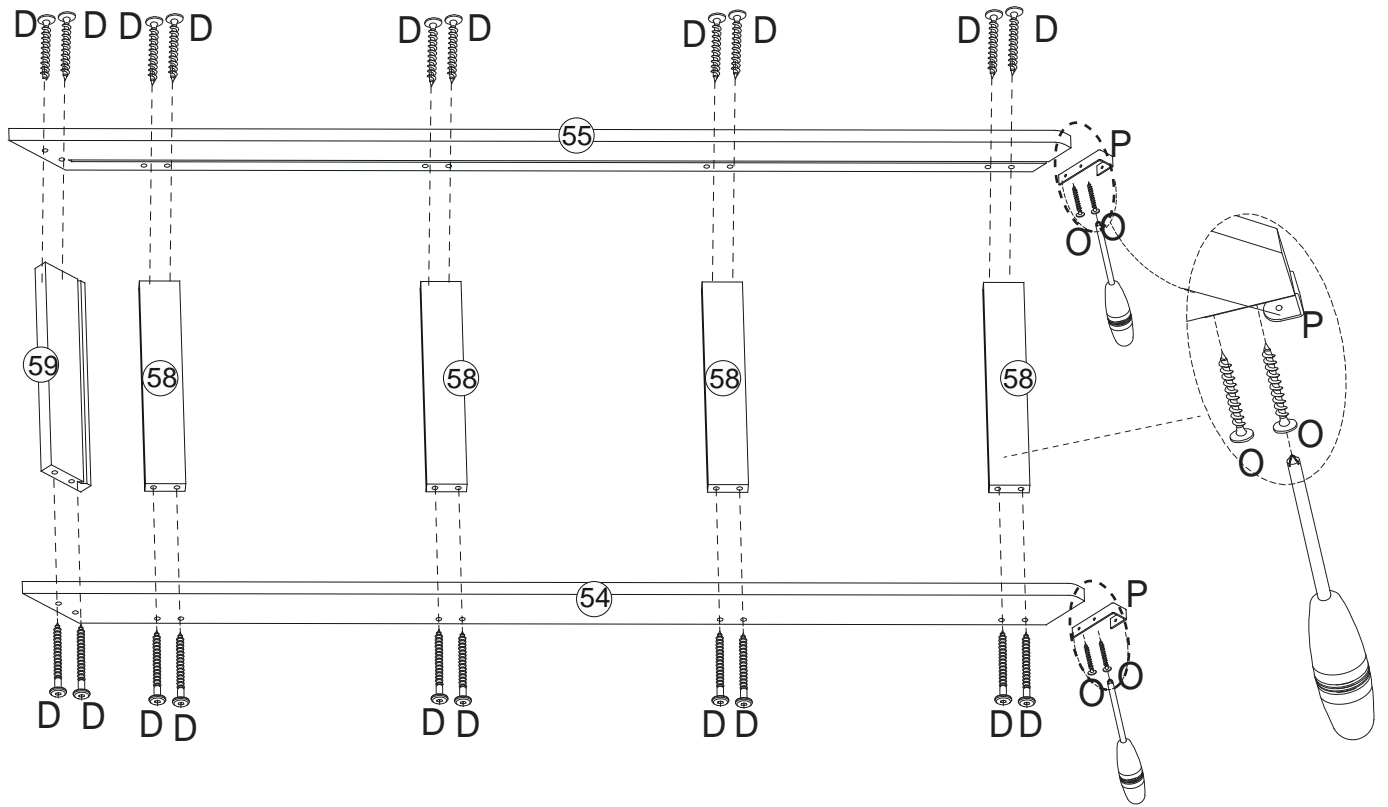

D ist auf 80 % festgelegt.

Schritt 24: Teil 57 zusammenbauen. D muss zu 100 % befestigt sein □

| | | | |
|---|--|---------|----|
| D | | Φ6x60 | 20 |
| O | | Φ3.5x16 | 4 |
| P | | | 2 |

Schritt 24

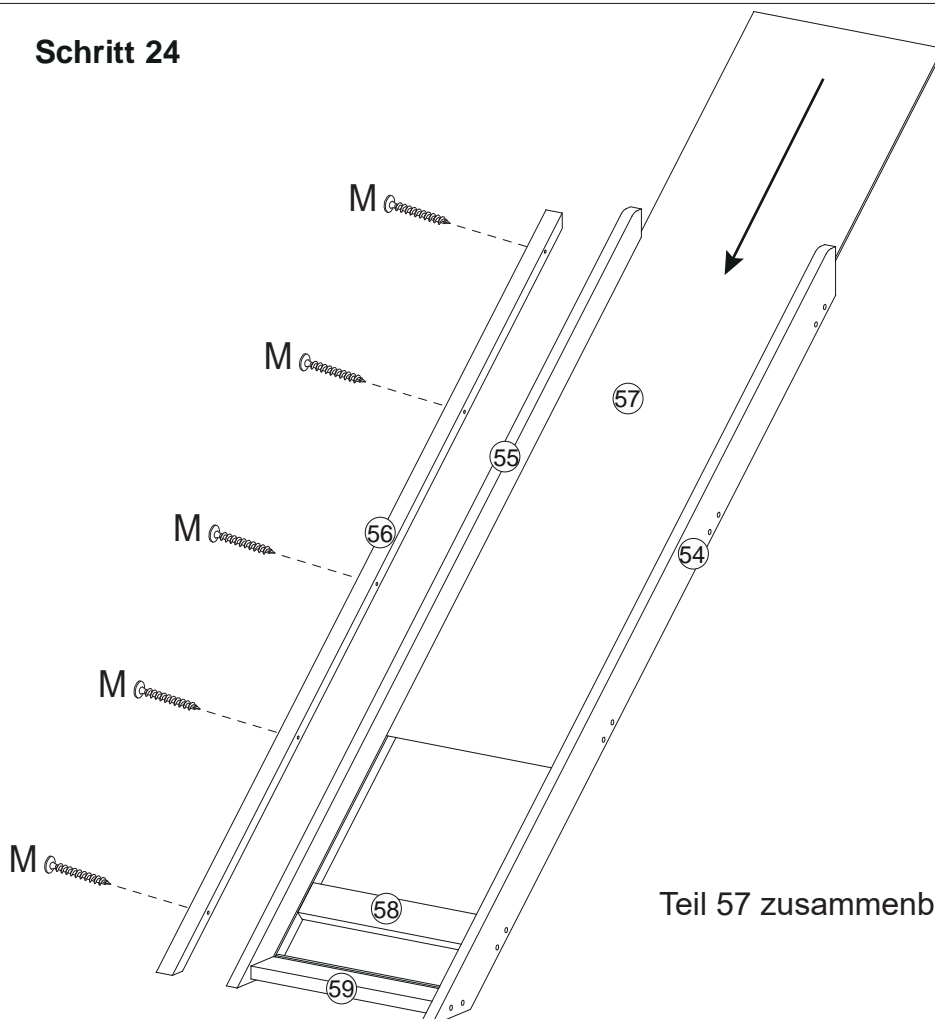

Teil 57 zusammenbauen. D muss zu 100 % befestigt sein □

| | | | |
|---|--|-------|---|
| M | | Φ4x40 | 5 |
|---|--|-------|---|

Schritt 25

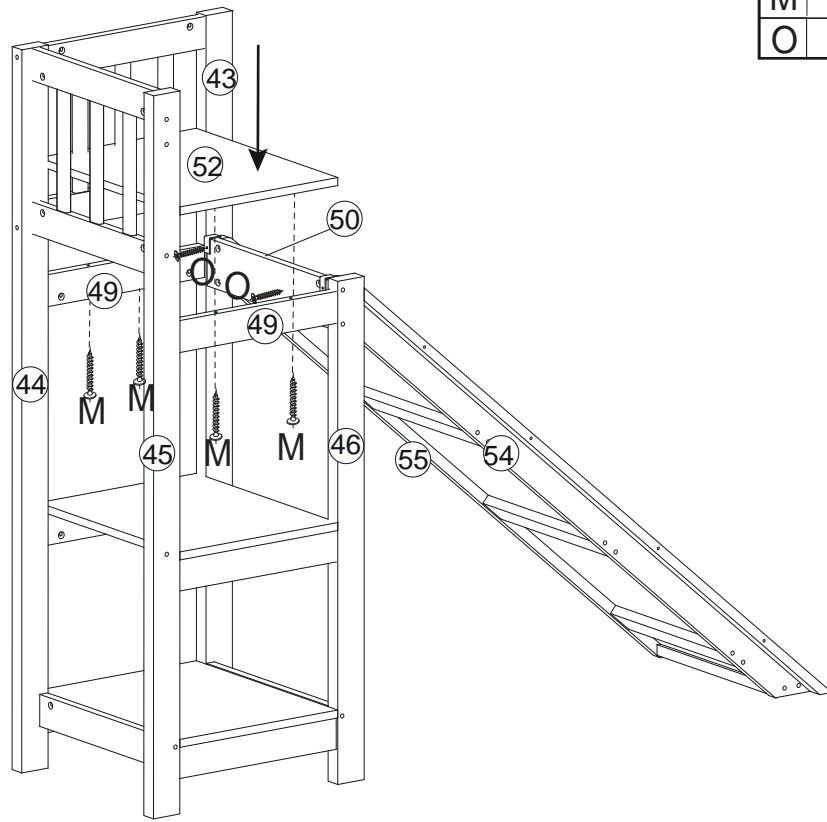

| | | | |
|---|--|---------|---|
| M | | Φ4x40 | 4 |
| O | | Φ3.5x16 | 2 |

Schritt 26

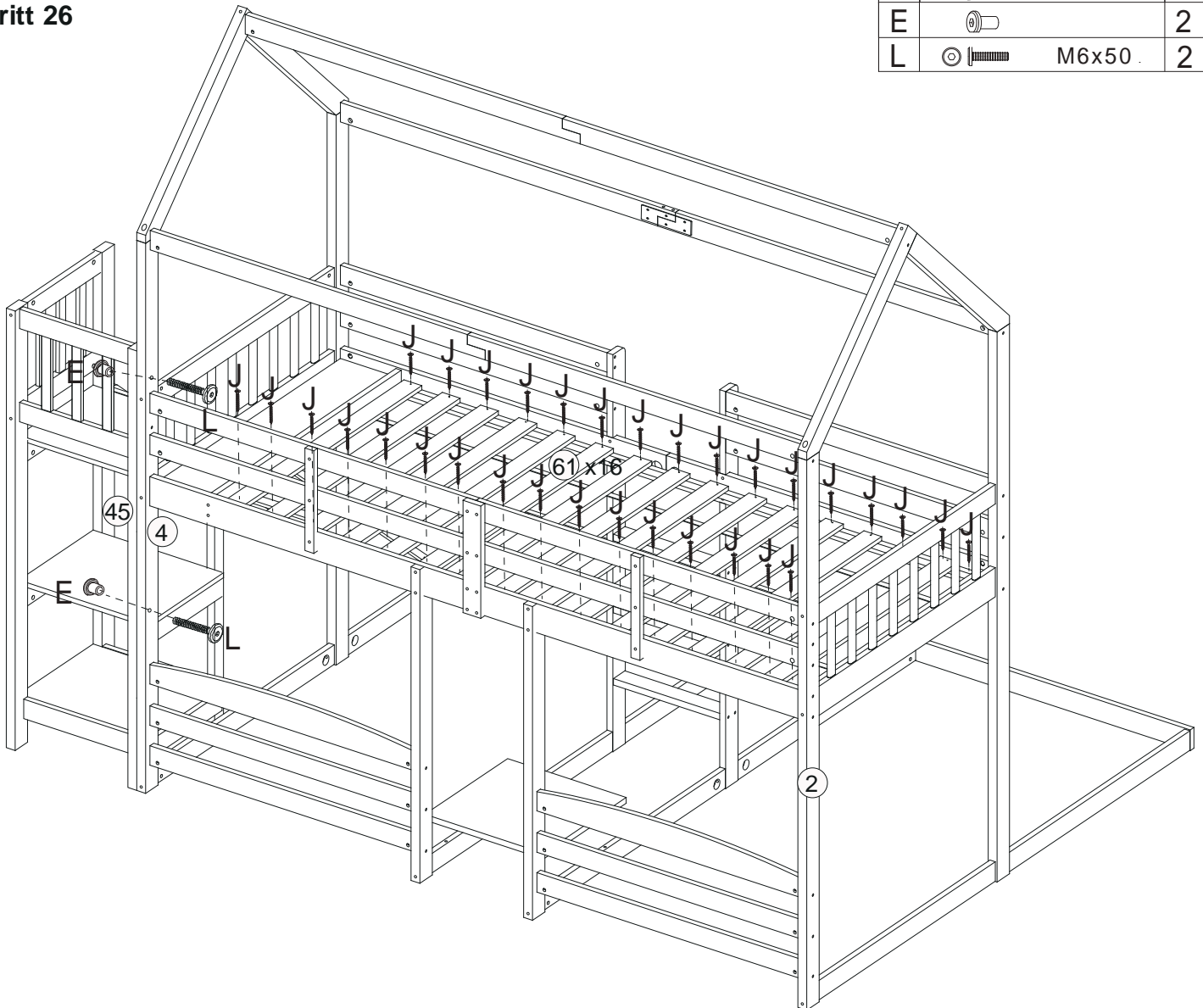

| | | | |
|---|--|-------|----|
| J | | Φ4x30 | 32 |
| E | | | 2 |
| L | | M6x50 | 2 |

Schritt 27

