

167590-1



167591-1

DK: Stolpefødder medfølger ikke, skal tilkøbes.

DE: Die Pfostenräger sind nicht im Lieferumfang enthalten und müssen separat erworben werden.

SE: Stolpskor ingår ej, måste köpas till.

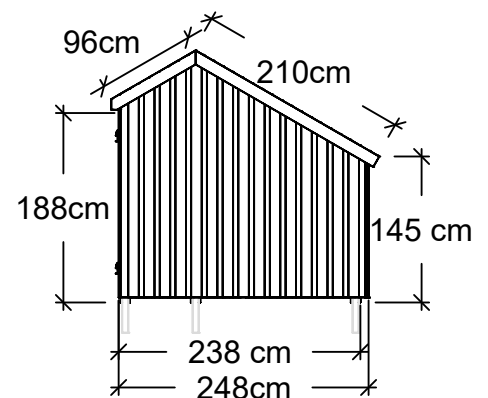
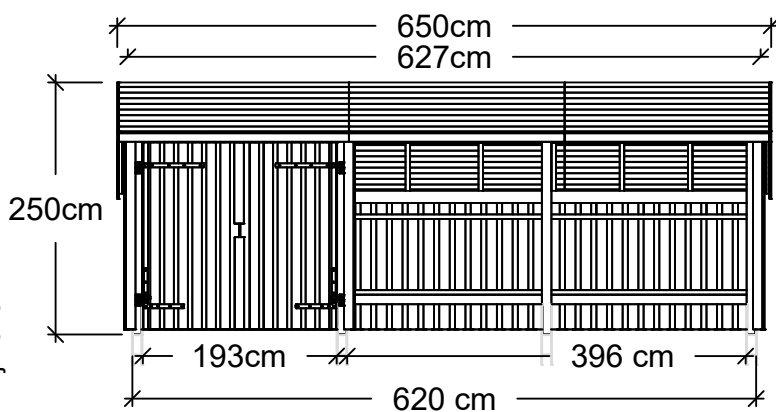

Revideret Maj 2023

Grundareal/ Bodenfläche/Byggyta:
6,20 x 2,38 = 14,8m²

Tag/Dach/Tak: 6,50x2,10 + 6,50x0,96 m

Tips / Tipps

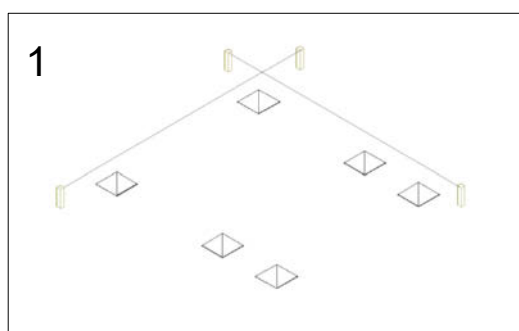
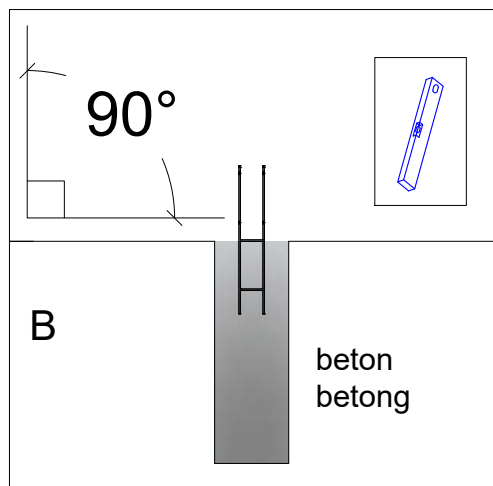
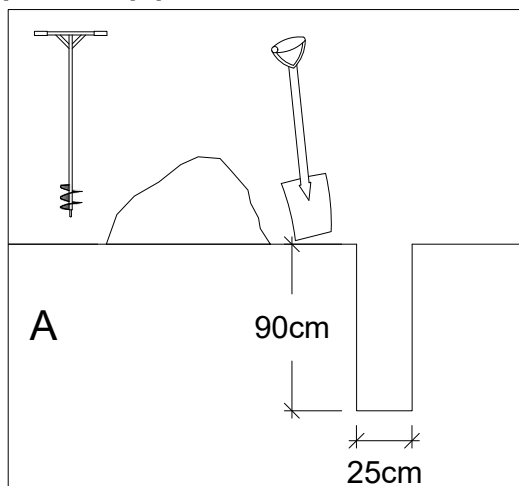

Viktig - at betonen omkring stolpen er hærdet op 3-5 dage før man fortsætter.

Es ist wichtig, dass der Beton um den Pfosten 3 bis 5 Tage aushärtet, bevor man mit der Montage fortfährt.

Viktigt - att betongen runt stolpen härdas 3-5 dagar innan du fortsätter med installationen.

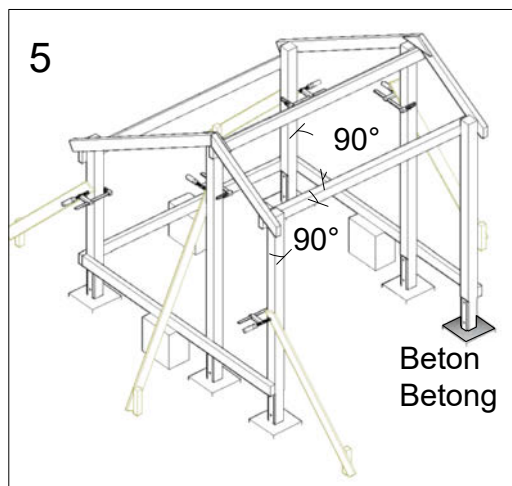
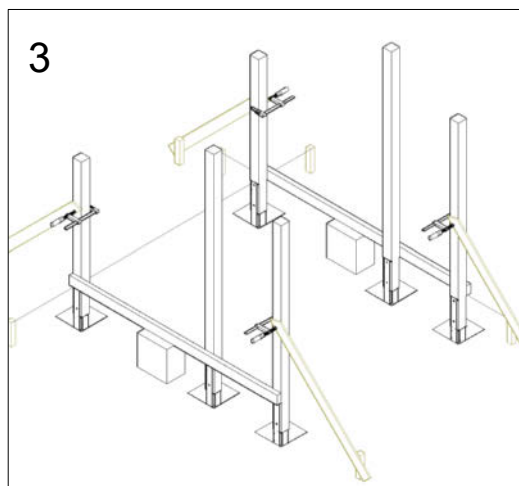
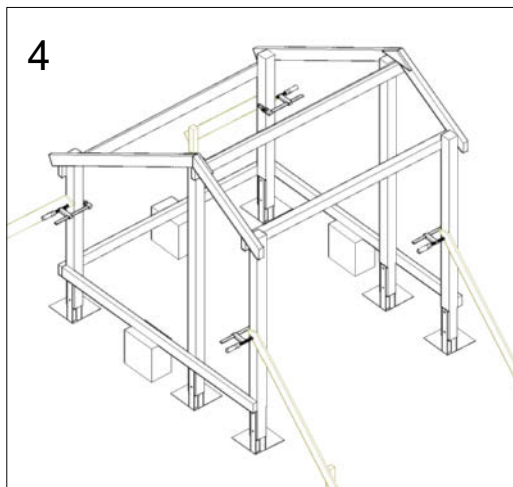
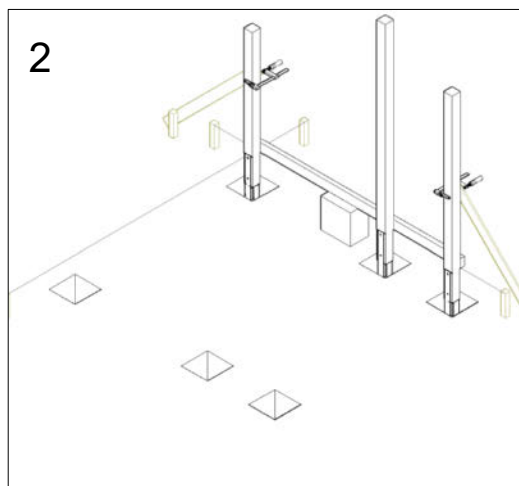

Multihus

Inden du starter montagen bør du gennemgå denne montagevejledning grundigt.

Åben emballagen og kontroller om indholdet stemmer overens med styklisten.

Skulle der mod forventning være mangler eller ødelagte dele, rettes henvendelse til den forhandler hvor produktet er købt.

Trædelene er ubehandlede og **skal** males inden montage.

Alle overflader (indvendigt og udvendigt) påføres en transparent eller heldækkende træbeskyttelse.

UBEHANDLEDE PRODUKTER:

På Plus.dk kan du finde yderligere information om hvordan du skal efterbehandle og vedligeholde produktet.

Sådan gør du:

Klik på  i topmenuen for at finde hjælp. Søg på **produkt navn** eller **varenummer** i søgefeltet på plus.dk og find alle de gode links med nyttig viden under det enkelte produkt.

Multihuset er modulopbygget :



Modulopbygningens konstruktion gør, at stolperne skal monteres med gaffel stolpefodder, der nedstøbes i beton.

Stolpefodder medfølger ikke, skal tilkøbes.

Taget er ikke dimensioneret til tungt tag (teglsten).

Vi anbefaler at der lægges tagpap på tag.

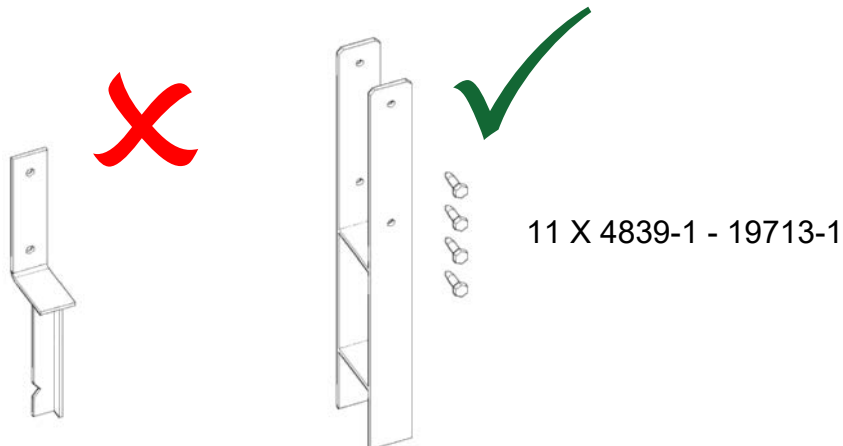

Multi-Gartenhaus

Bevor Sie mit der Montage beginnen sollten Sie die Anleitung gründlich durchlesen.

Öffnen Sie die Verpackung und überprüfen Sie die Vollständigkeit anhand der Stückliste.

Sollte wider Erwarten ein Mangel oder Schäden festgestellt werden, wenden Sie sich bitte an den Händler bei dem Sie das Produkt erworben haben

Die Holzteile sind unbehandelt und **müssen** vor der Montage behandelt werden.

Alle Oberflächen (innen und außen) mit einem transparenten oder deckenden Holzschutzmittel behandeln.

Unbehandelte Produkte:

Auf www.plus.dk/de finden Sie weitere Informationen über die Nachbehandlung und Pflege vom Produkt.

So geht es:

Klicken Sie auf  im Topmenü um Hilfe zu finden. Suchen Sie nach dem Produkt oder der Artikelnummer im Suchfeld auf www.plus.dk/de und finden Sie alle guten Links mit nützlichen Wissen unter dem jeweiligen Produkt.

Das Multi-Gartenhaus besteht aus einer modularen Bauweise.



Die Konstruktion der modularen Bauweise erfordert es, dass die Pfosten auf Gabel-Pfostenträgern montiert werden müssen, die einbetoniert werden müssen.

Die Pfostenträger sind nicht im Lieferumfang enthalten und müssen separat erworben werden.

Die Dachkonstruktion ist nicht für schwere Dachlösungen (Dachziegel) dimensioniert.

Wir empfehlen daher, dass Dachpappe als Dachlösung verwendet wird.

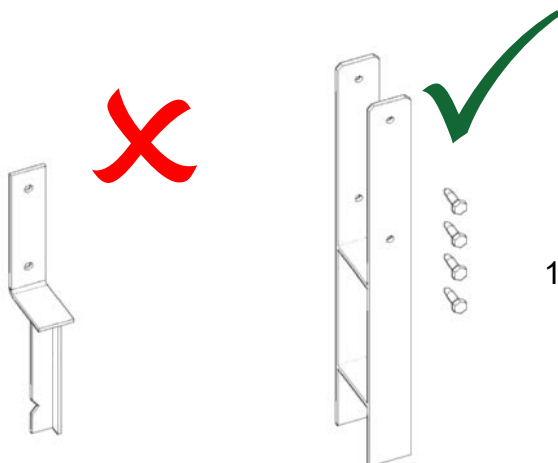

11 X 4839-1 - 19713-1

Multihus

Innan monteringen påbörjas bör du noggrant gå igenom dessa monteringsanvisningar.

Öppna förpackningen och kontrollera att innehållet stämmer överens med stycklistan.

Om det mot förmodan skulle finnas några defekter eller trasiga delar ska du kontakta den återförsäljare du köpte produkten av.

Trädelarna är obehandlade och **ska** målas före monteringen.

På alla ytor (invändiga och utvändiga) ska ett transparent eller heltäckande träskydd appliceras.

OBEHANDLADE PRODUKTER:

På Plus.dk finns det ytterligare information om hur du ska efterbehandla och underhålla produkten.

Så här gör du:

Klicka på  i den övre menyn för att få hjälp. Sök på din produkt eller ditt artikelnummer i sökrutan på

plus.dk och hitta alla bra länkar med nyttig information under varje enskild produkt.

Multihuset är modulbyggt:



Modulbyggnadens konstruktionen innebär att stolparna ska monteras med stolpskor med gaffel, som gjuts i betong.

Stolpskor ingår ej, måste köpas till.

Taket är inte dimensionerat för tungt tak (tegel).

Vi rekommenderar att belägga taket med takpapp.

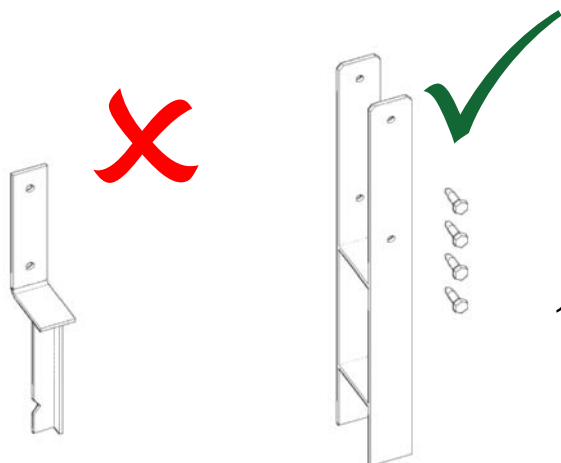

11 X 4839-1 - 19713-1

(16759-1)

167590-1 167591-1

Tolerance +/- 5mm

POS	Antal		MM	POS	Antal		MM
A-1	4		95x95x1532	E-1	2		30x50x2080
A-2	4		95x95x2045	E-2	2		30x50x974
A-4	3		95x95x2248	E-3	1-1	 V H	18x95x1998
B-1	2		45x95x2380	E-5	2		18x120x2104
B-5	2		45x95x2124	E-6	2		18x120x1019
B-6	1		45x95x2031	E-7	3		18x85x2280
B-7	4		45x120x2124	F-1	3		1320x2216
B-8	2		45x120x2031	F-2	1		2442x2429
B-9	3		45x120x2380	F-3	1		2442x2429
B-11	2		45x120x1948	F-4	10		19x100x1320
B-12	1		45x120x1517	F-5	2		19x100x2185
C-1	10		45x95x2080		1		
C-2	10		45x95x993				x 11
C-3	17		18x100x346				x 745 4 x 50 mm
C-4	7		18x100x1270				x 165 5 x 100 mm
D-4	24		2280				x 40 5 x 90 mm
D-5	24		2140				x 32 4 x 80 mm
D-6	24		2031				
D-7	2		2280				
D-8	2		2140				
D-9	2		2031				
D-10	2		2280				
D-11	2		2140				
D-12	2		2031				

(16752-1) 167590-1 167591-1



POS	Antal		MM		
G	1		1.1	1006x1855	2446-1 1
			1.2	930x1855	
			1.3	19x95x1930	
Oa	1			2446-1	
Ob	1				
P	2				
Q	4			2446-1	
R	2				
S	4				

(16754-1) 167590-1 167591-1

F	1		2442x2429	E-3	1		18x95x1998
B-1	1		45x95x2380				
F5	1		19x100x2185				
F6	1		19x100x2104				
F7	1		19x100x2380				

(16755-1) 167591-1

B-13	1		45x95x1935	G1	1		20x120x1930
F8	2		966x1840				
F9	3		19x100x1840				

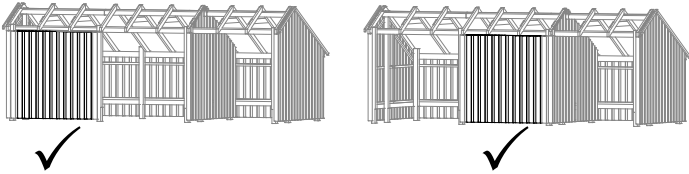
<u>167590-1</u>		Side/Seite/ sida
		9
Konstruktion	16759-1	10-16 19-20
Dør - Tür - Dörr	16752-1	21-24
Indvendig, højre gavl - Rechter Giebel Innenseite Invändigt, höger gavel	16754-1	16-17
<u>167591-1</u>		Side/Seite/ sida
		9
Konstruktion	16759-1	10-16 19-20
Dør - Tür - Dörr	16752-1	21-24
Indvendig, højre gavl - Rechter Giebel Innenseite Invändigt, höger gavel	16754-1	16-17
 <p>✓ ✓</p> <p>Placering - Platzierung</p>		18

167590-1 Stolpeplan - Pfostenplan

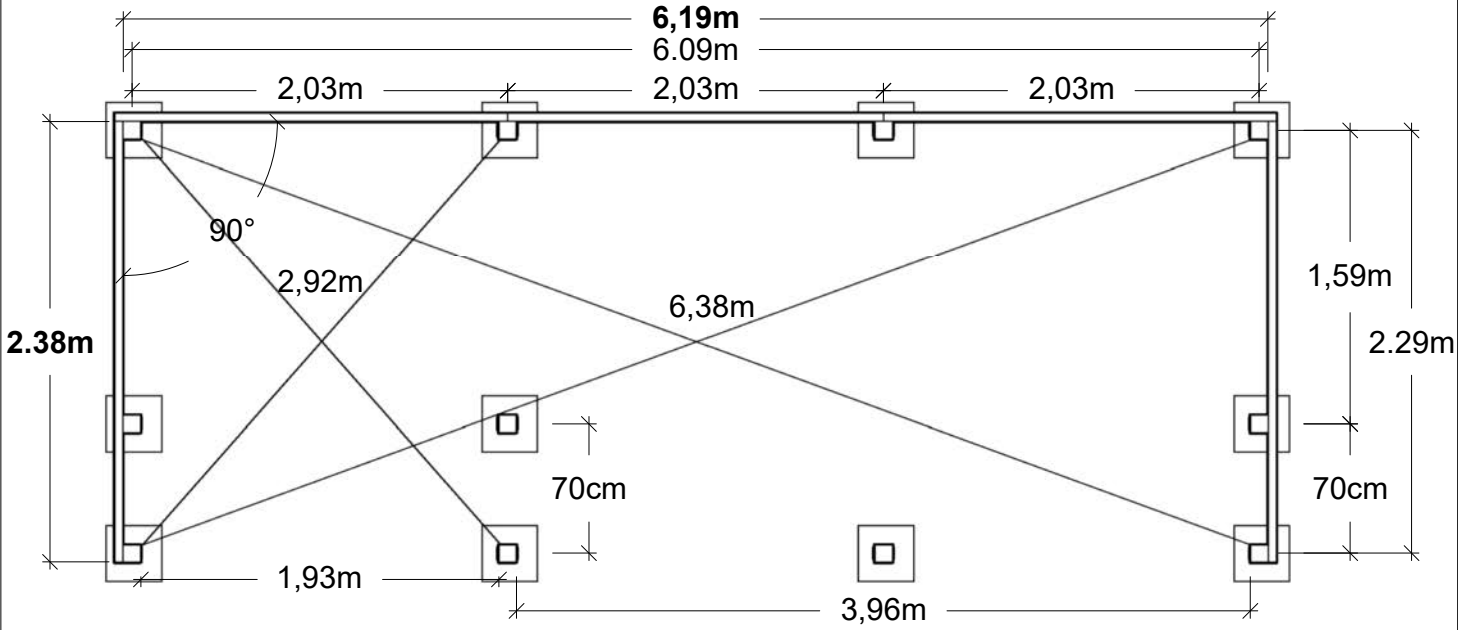

167591-1 Stolpeplan - Pfostenplan

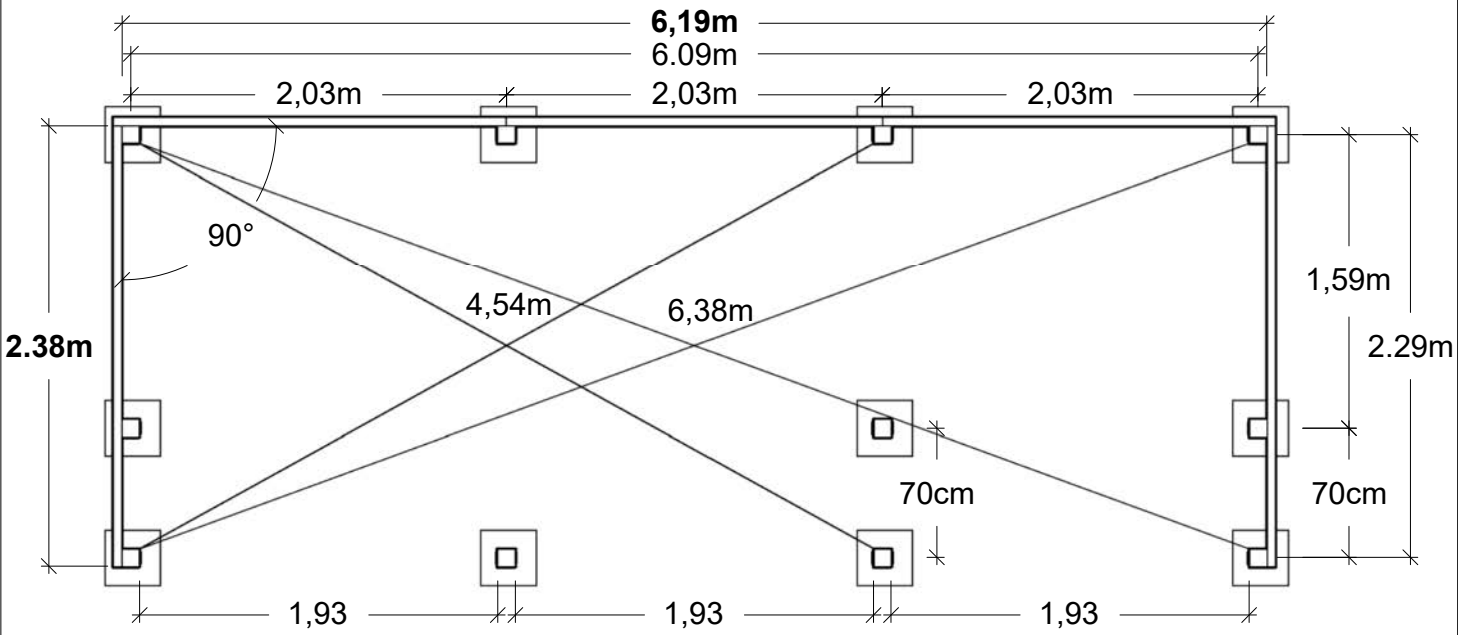

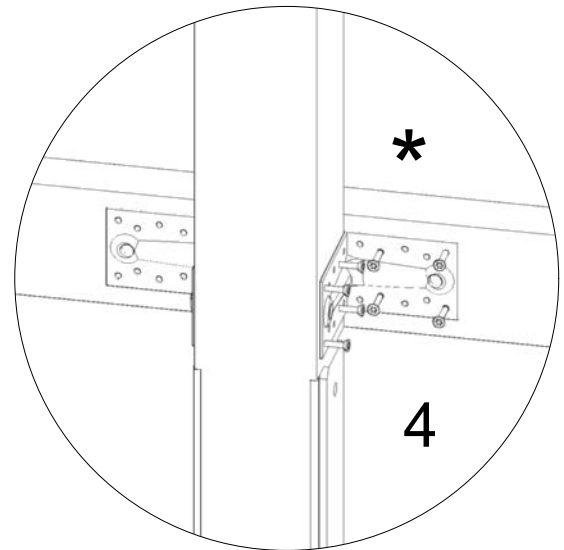
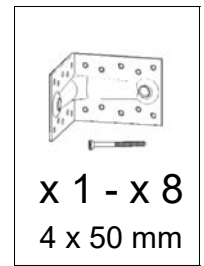
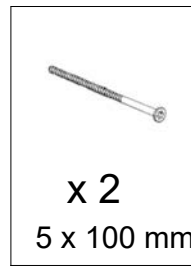
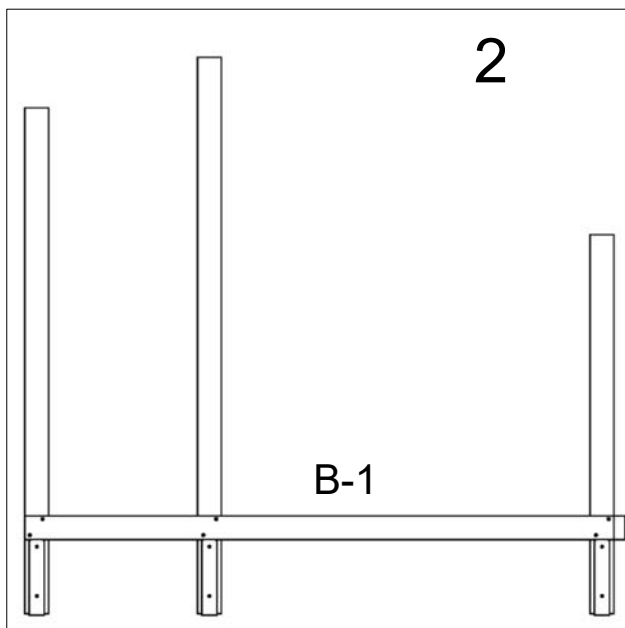
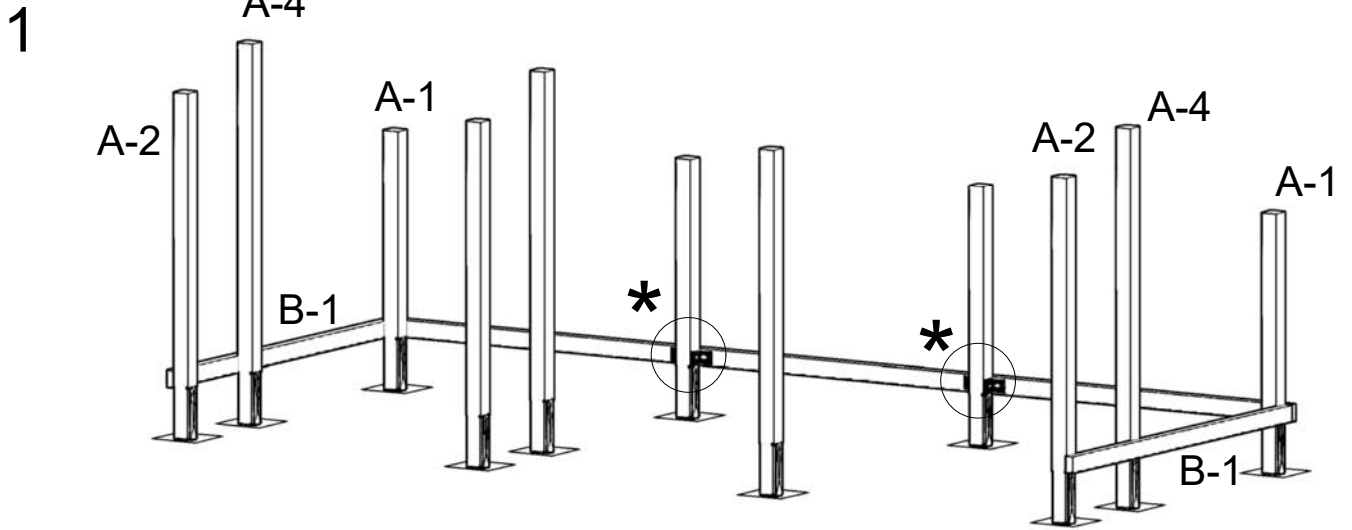

3

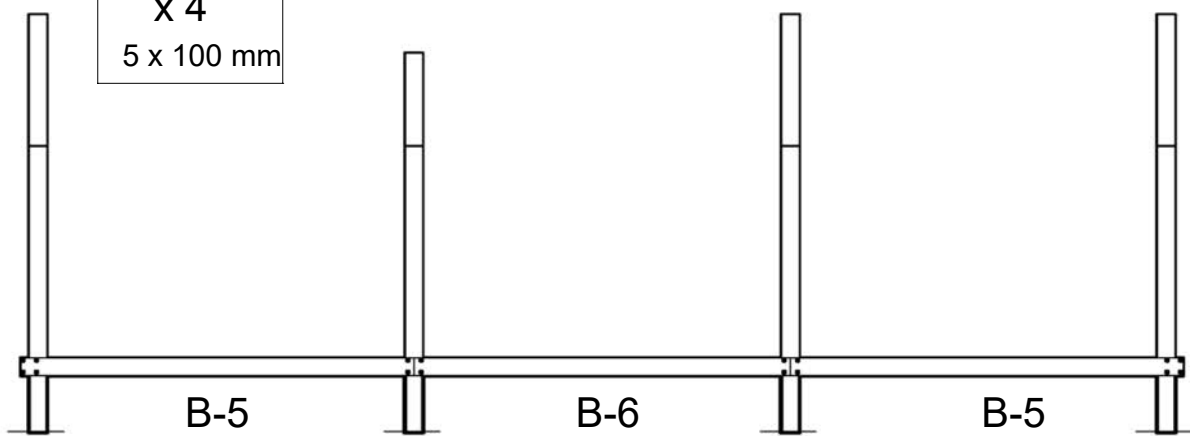
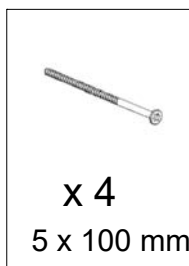

5

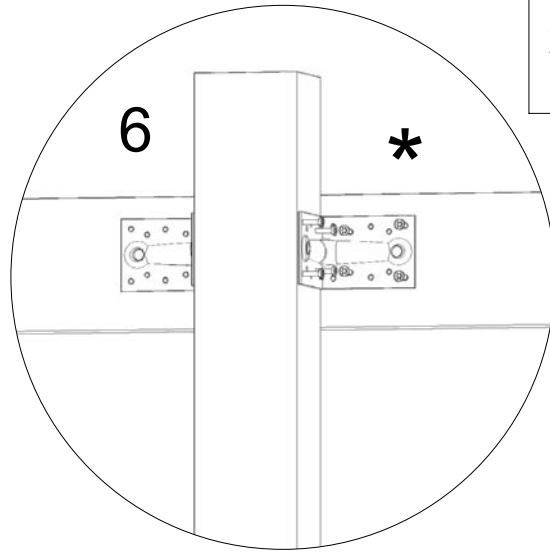
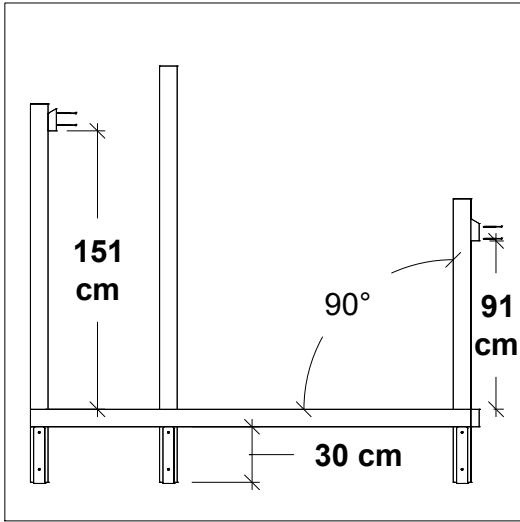
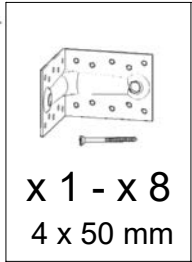
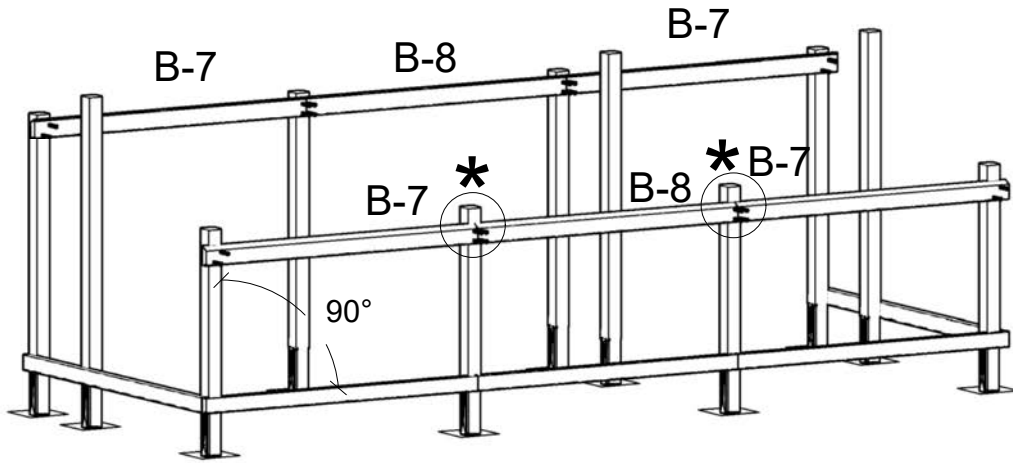
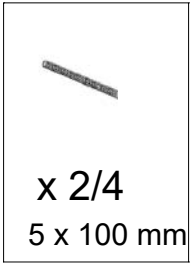

7

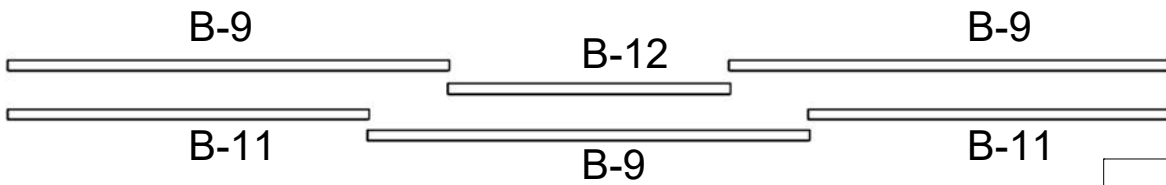

DK: Kiprem limes med trælím og skrues sammen.

DE: Der Trägerbalken muss mit Holzleim verleimt werden und zusammengeschaubt werden.

SE: Överliggaren limmas med trälim och skruvas ihop.

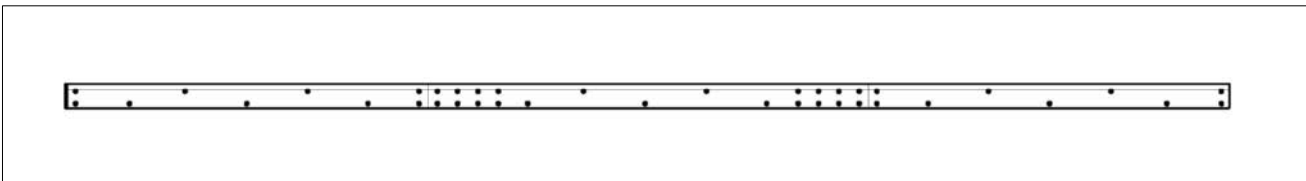
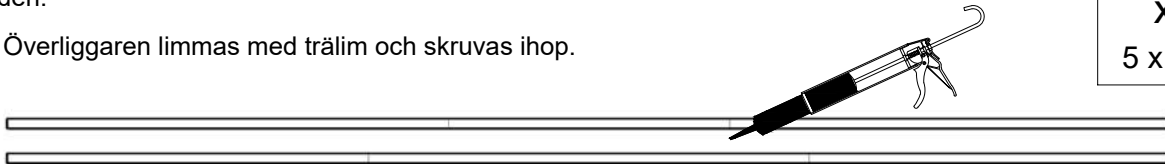
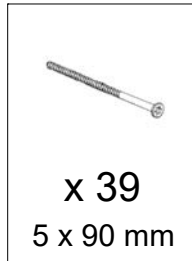

8

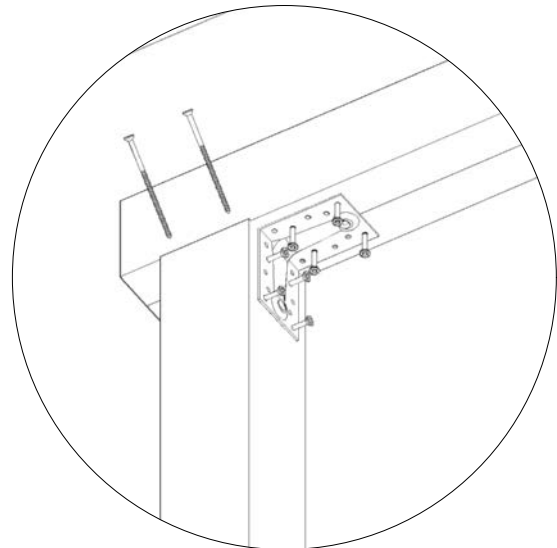
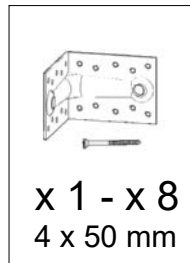
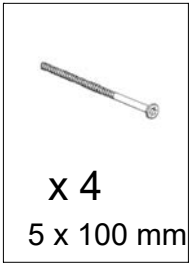
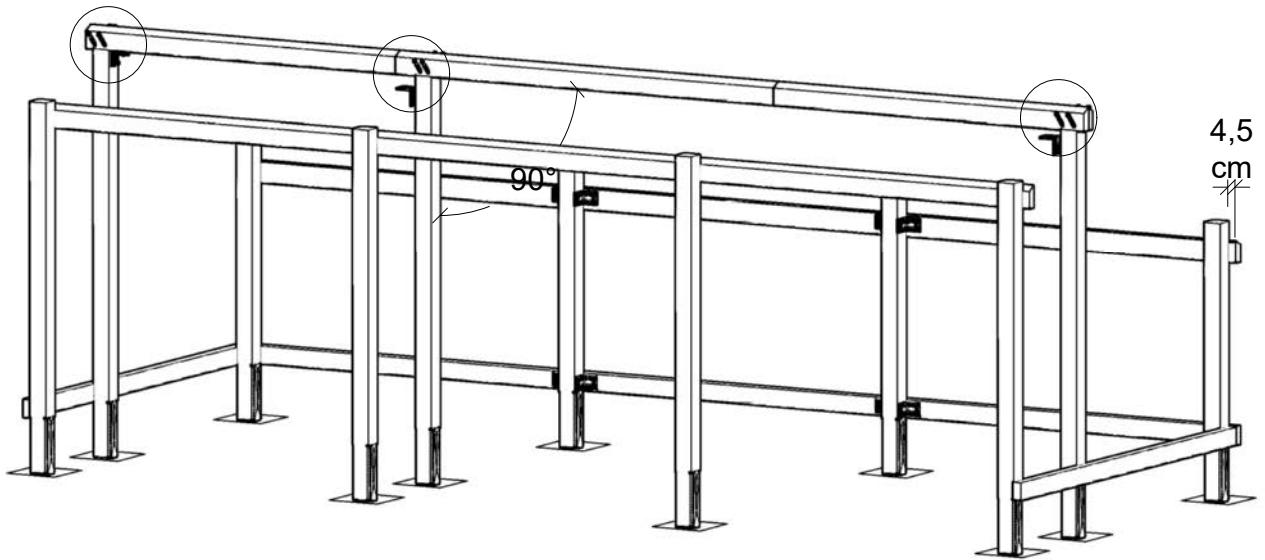

9

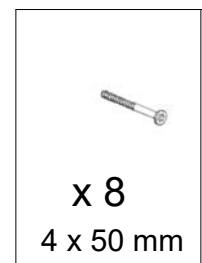
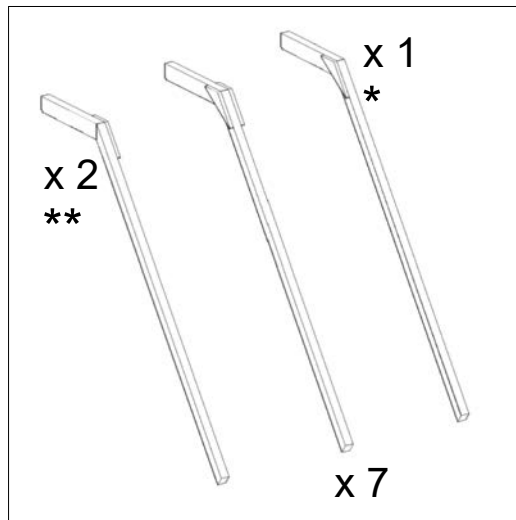
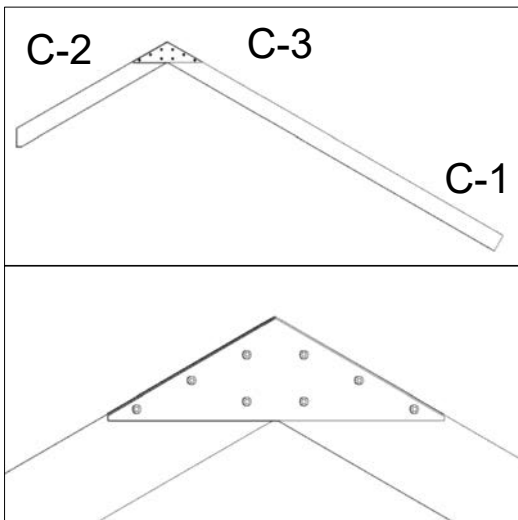

10

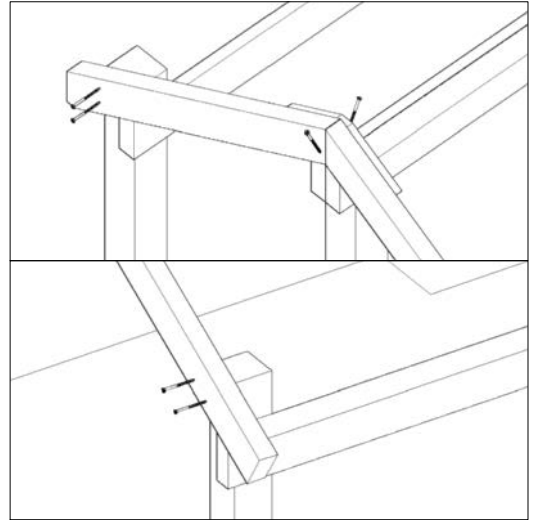
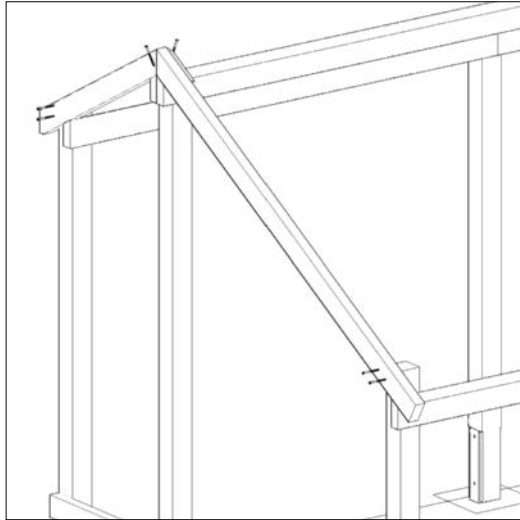
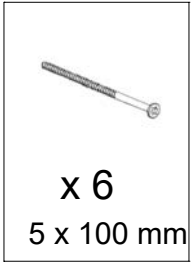

11

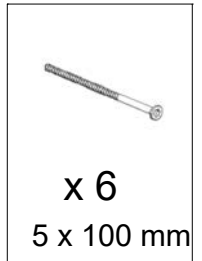
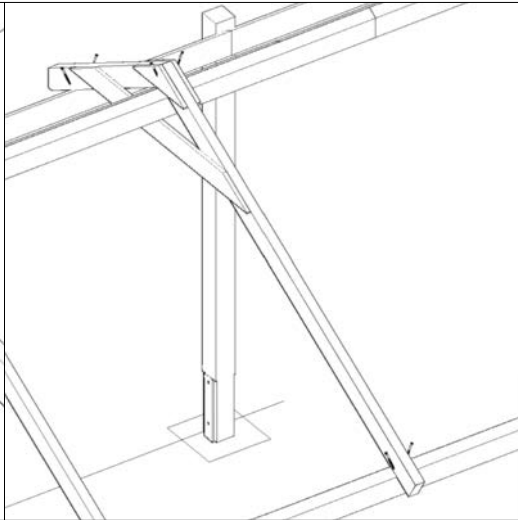
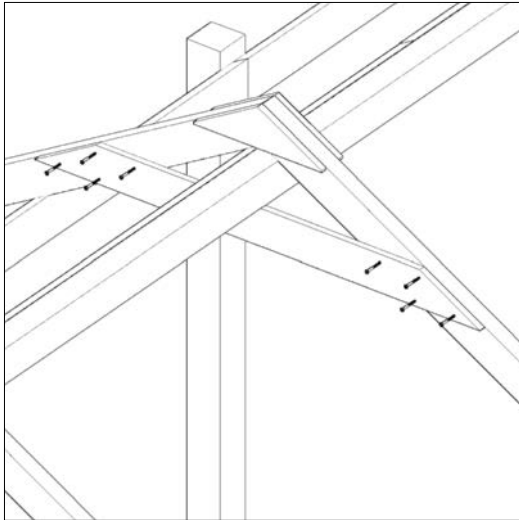
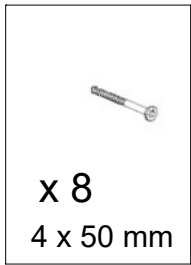

12

167590-1

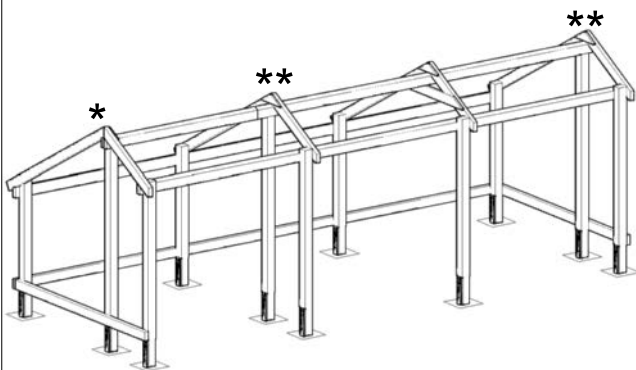

167591-1

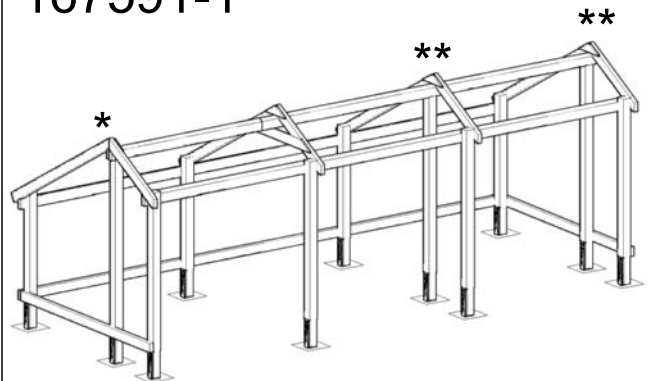

13 De øvrige spær fordeles - Die restlichen Dachsparren verteilen - De övriga takstolarna fördelas jämnt

167590-1

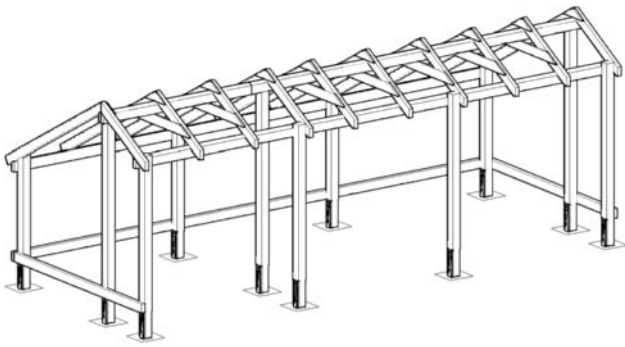

167591-1

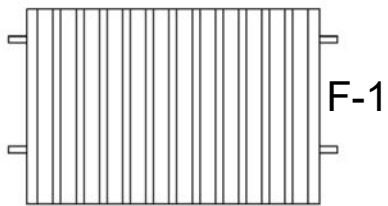
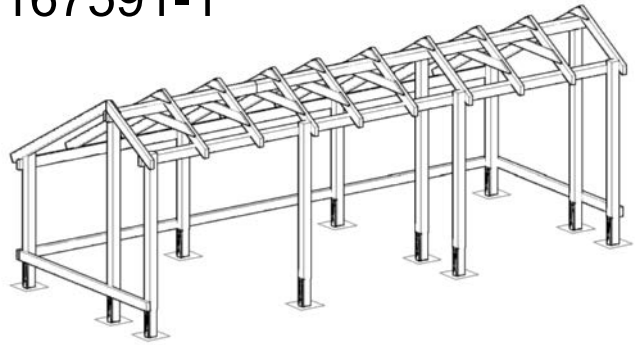

14

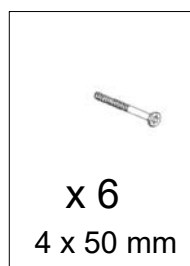
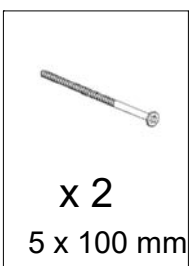
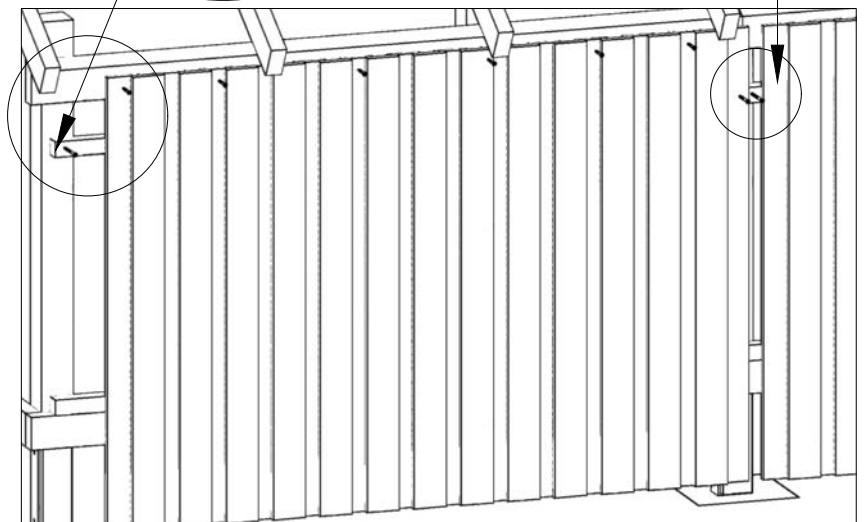
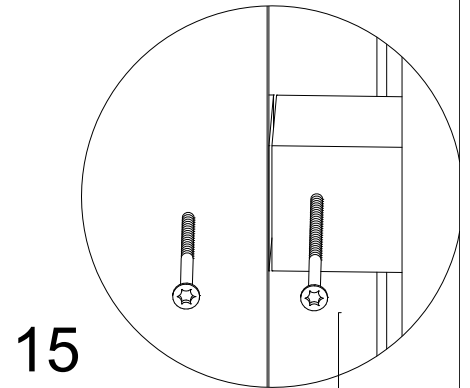
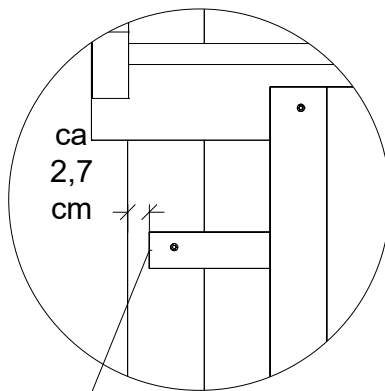
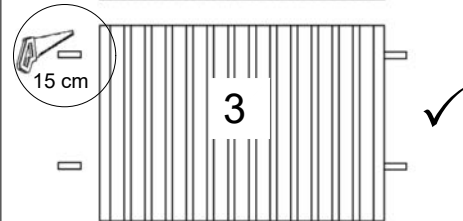
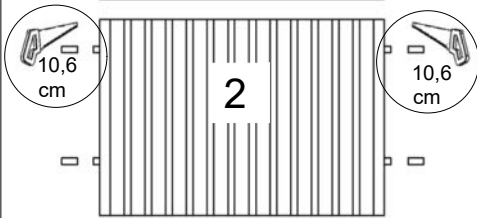
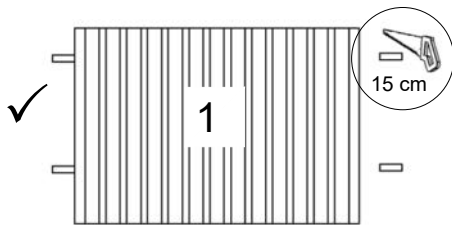
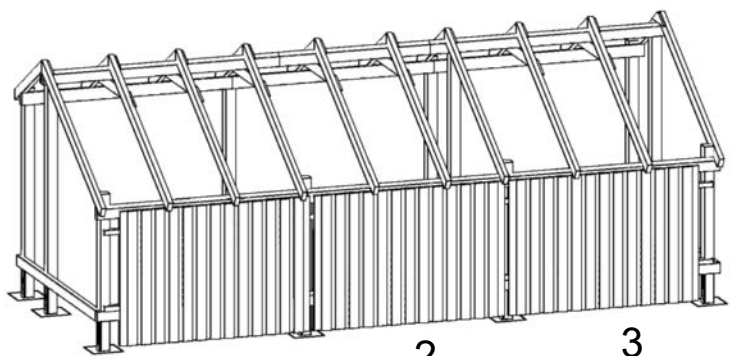

16

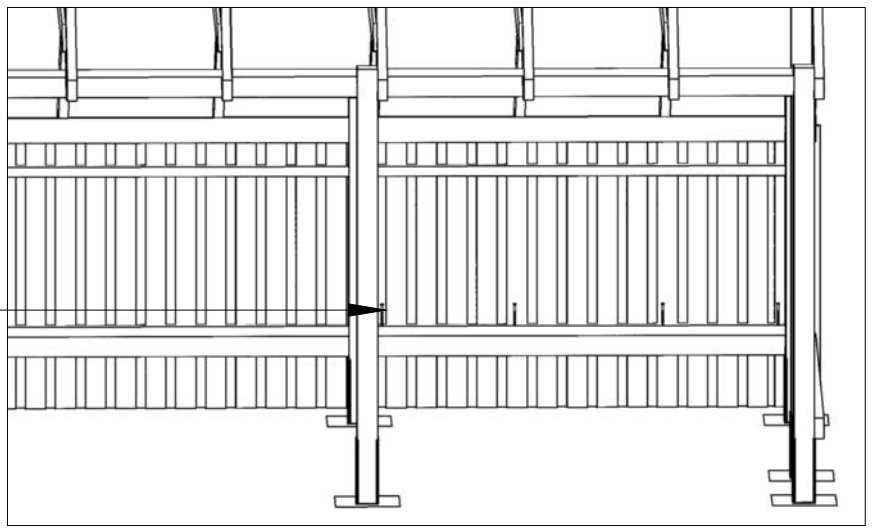
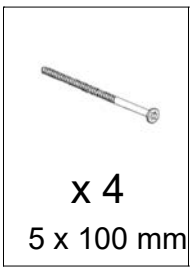
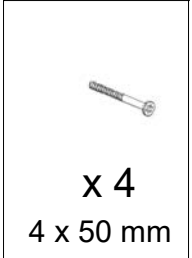

17

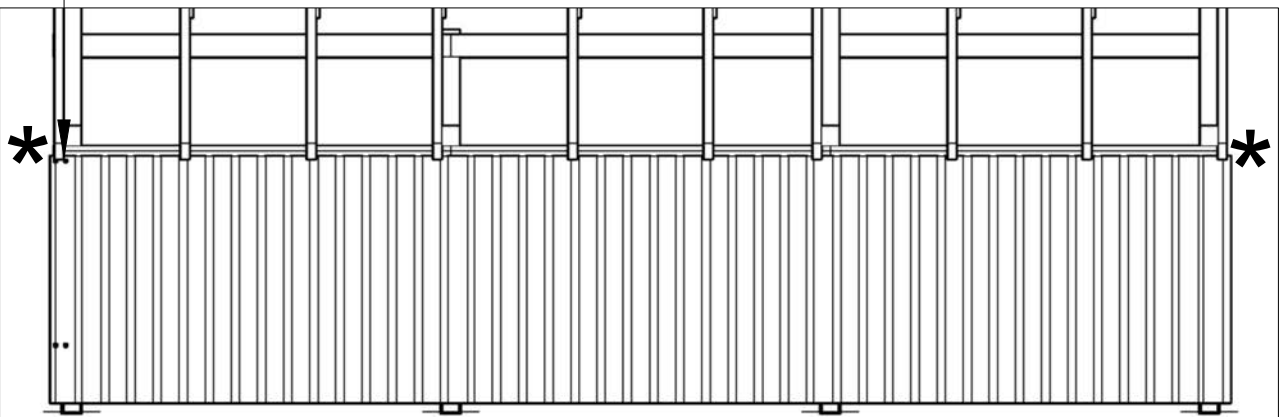

F-4

x4

x1

x1

x4

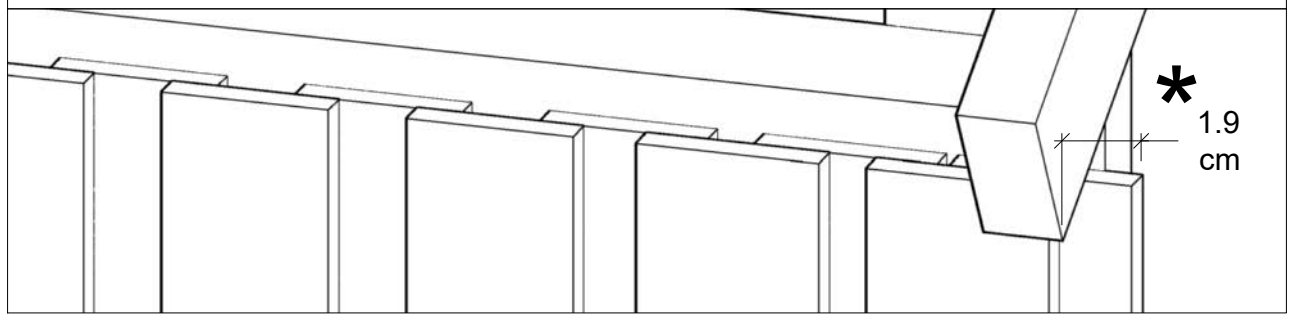

F-3

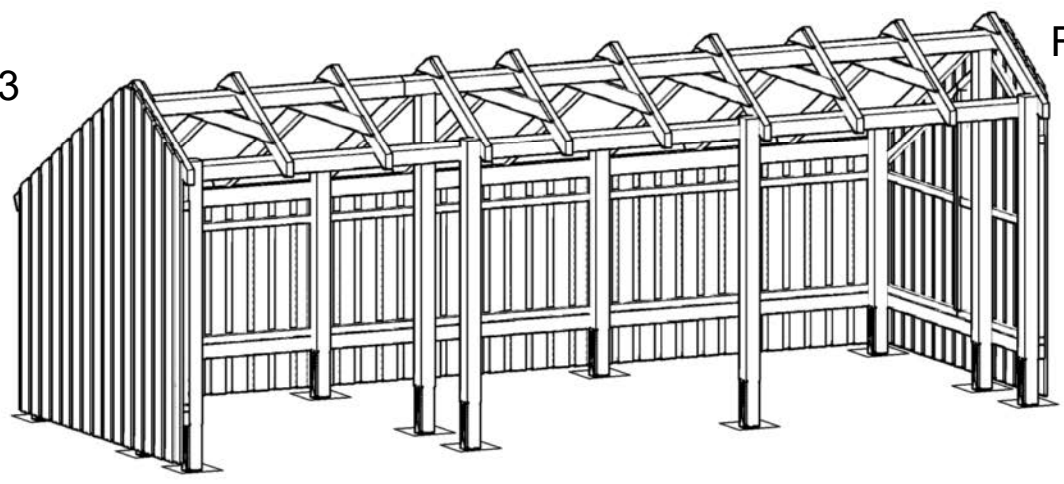

F-2

18

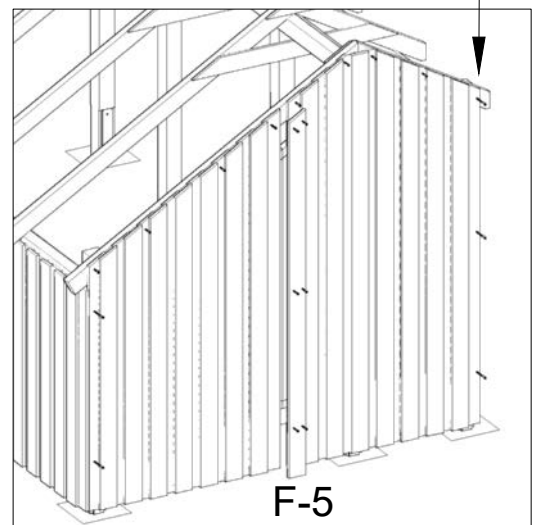
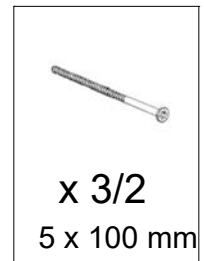
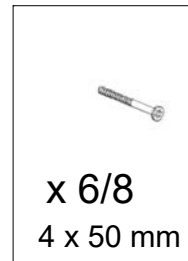
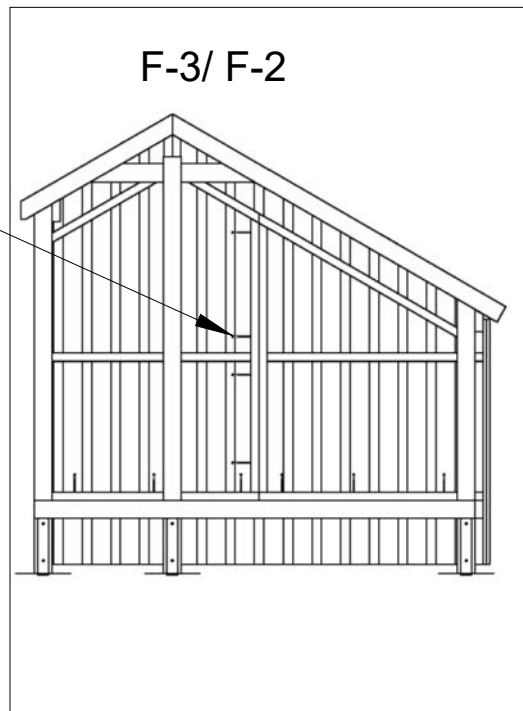
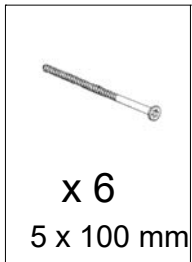
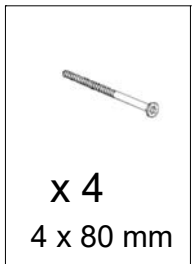

19

167590-1

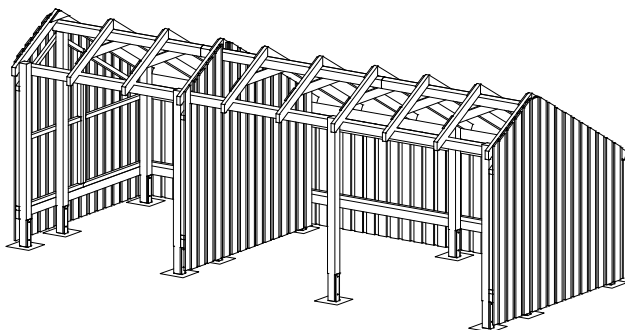

167591-1

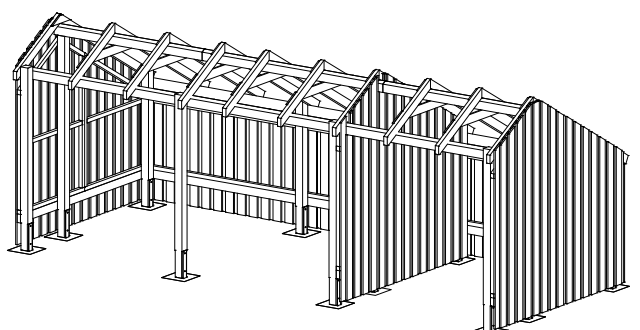

20

16754-1

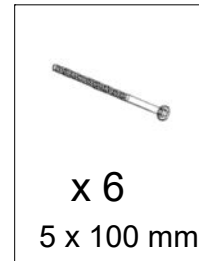
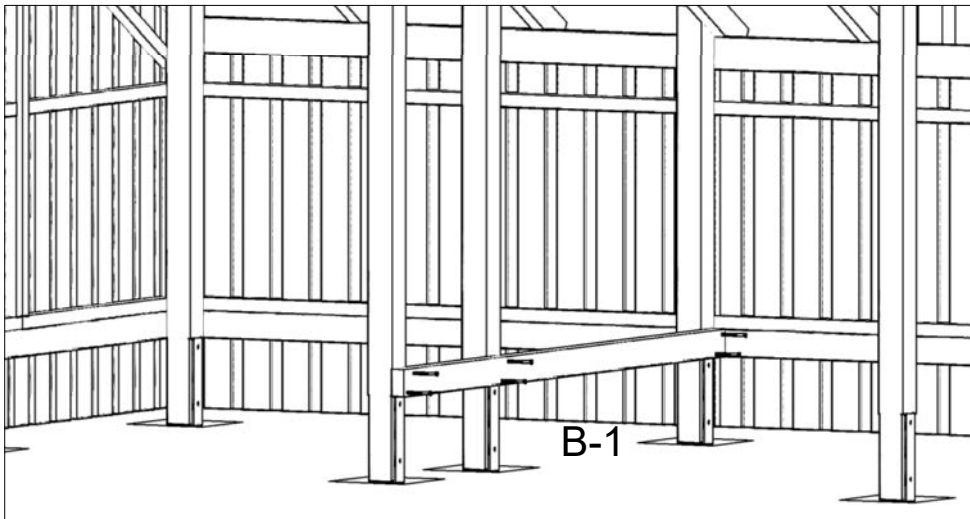

21

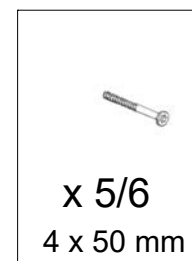
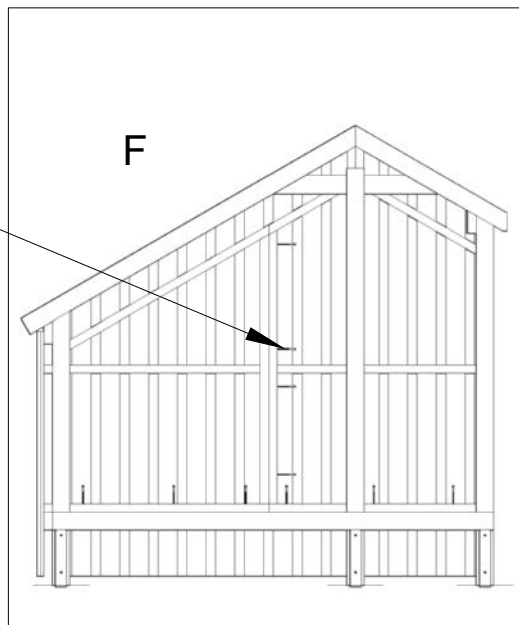
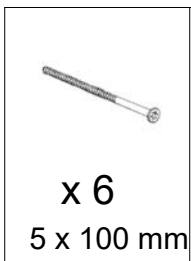
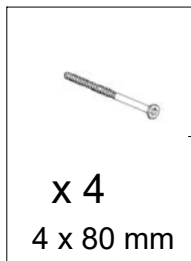

22

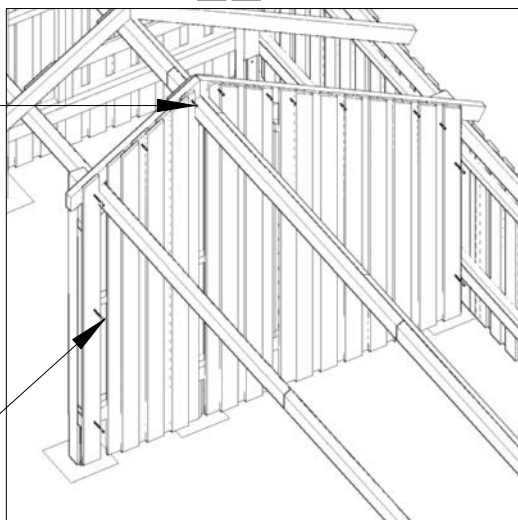
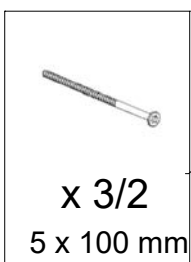
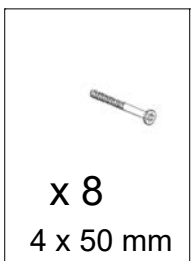

23

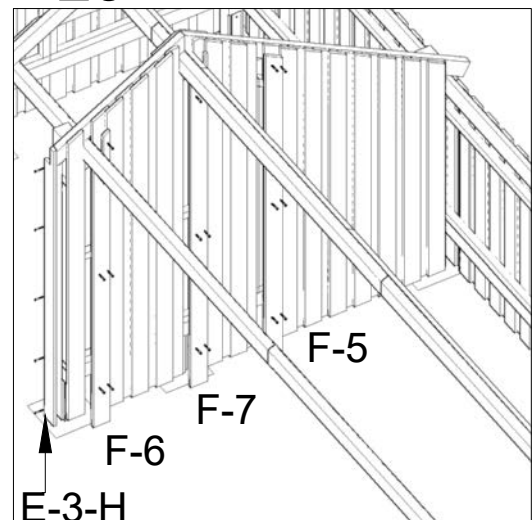

16755-1

167591-1

1

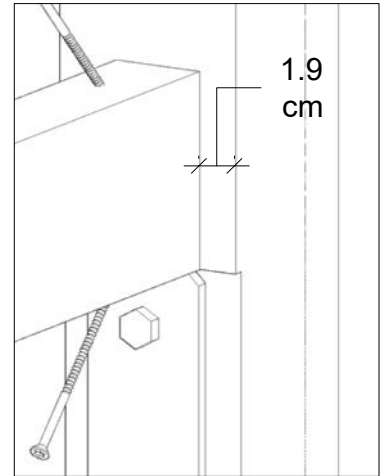
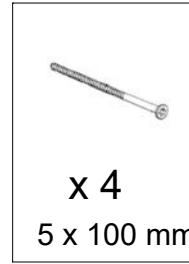
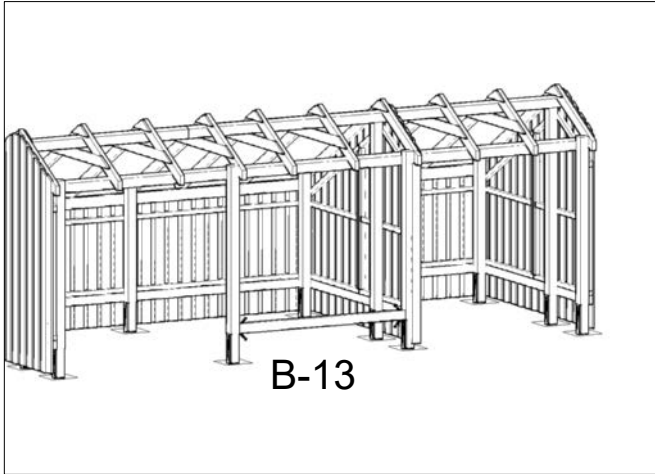

2

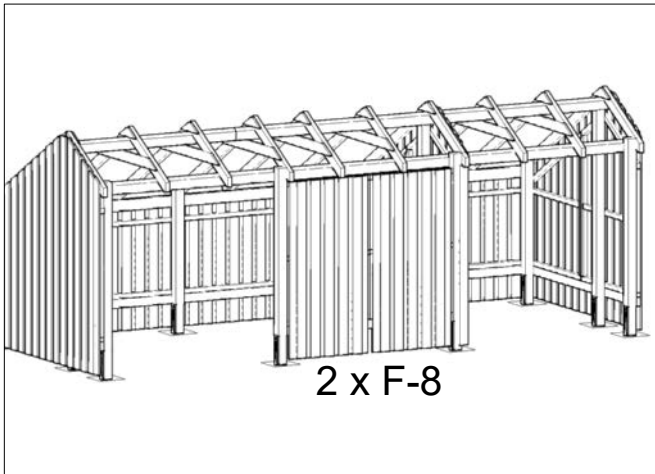

3

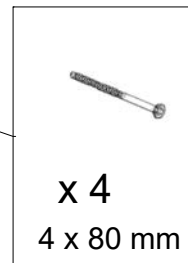
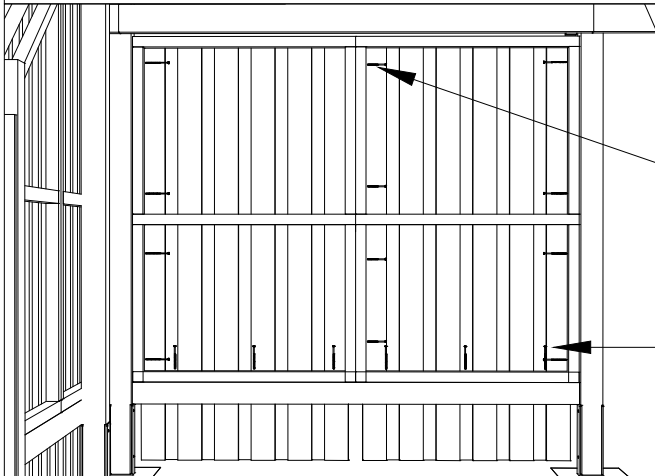

4

G-1

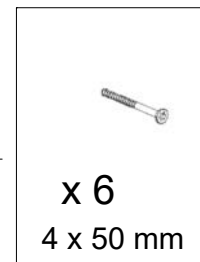
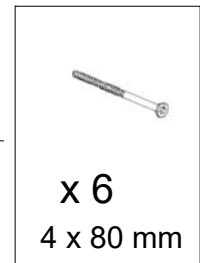
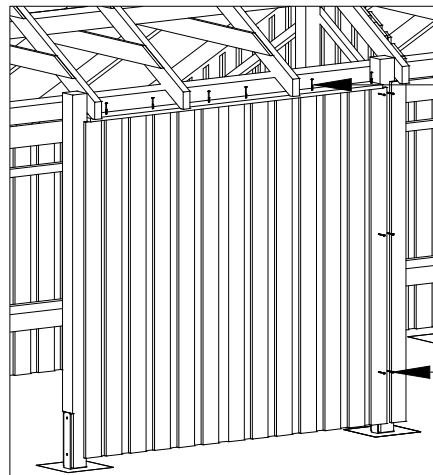
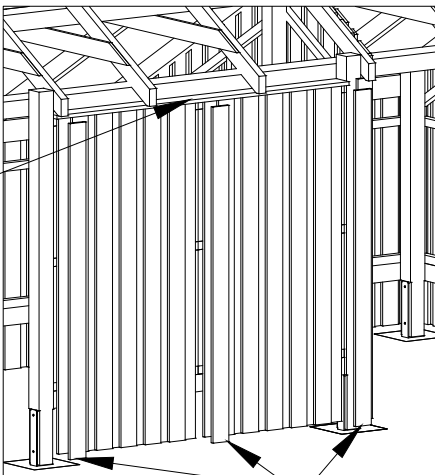

24

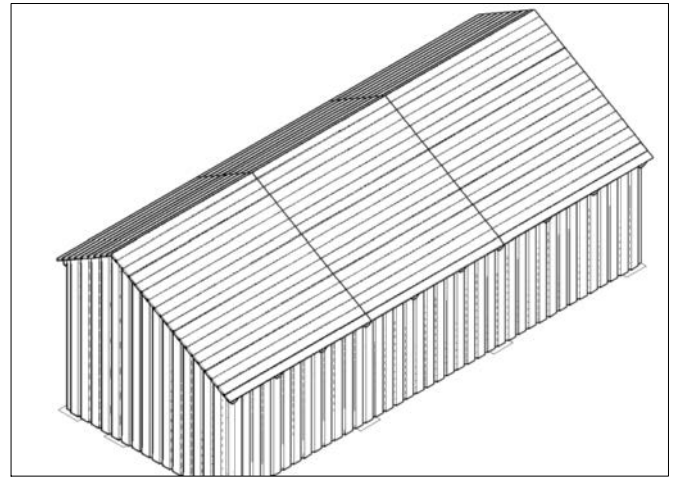
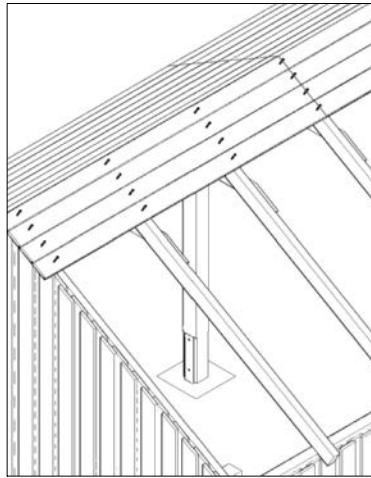
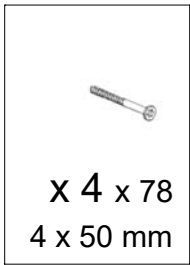
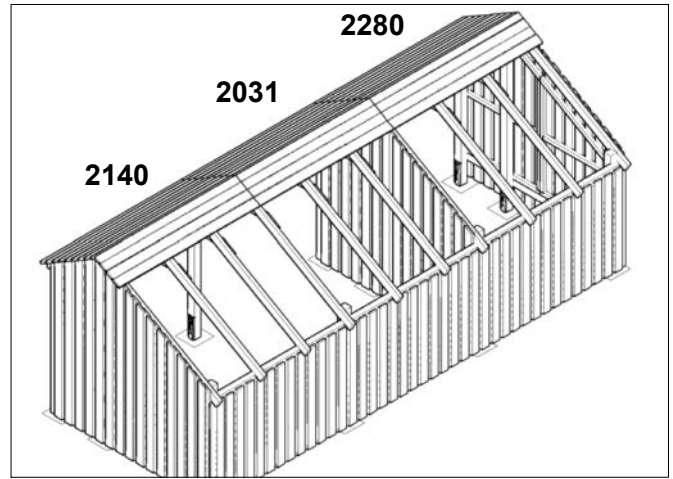
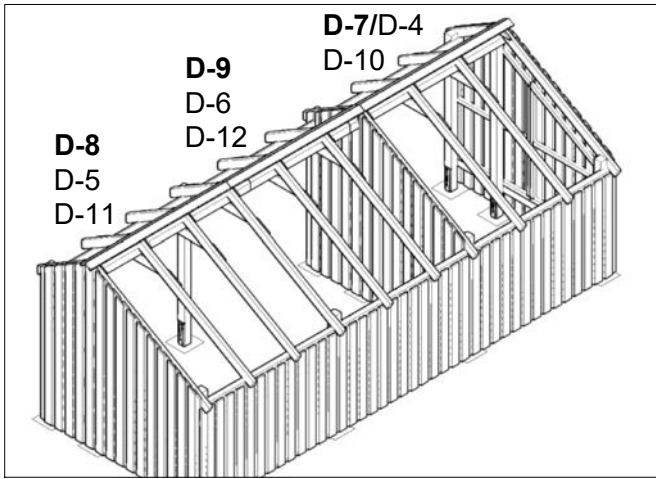

25

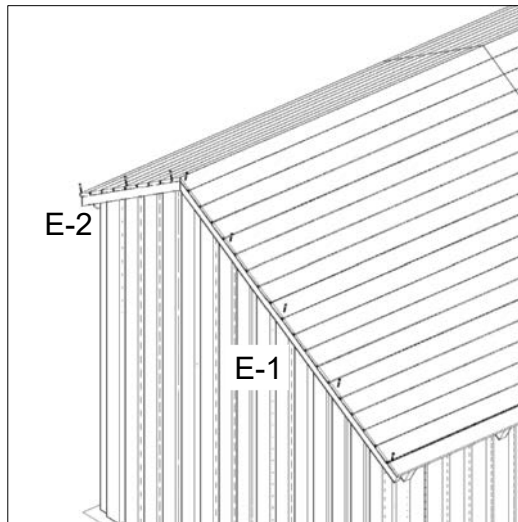
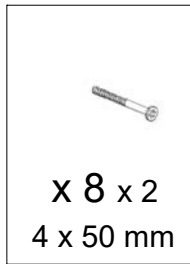

26

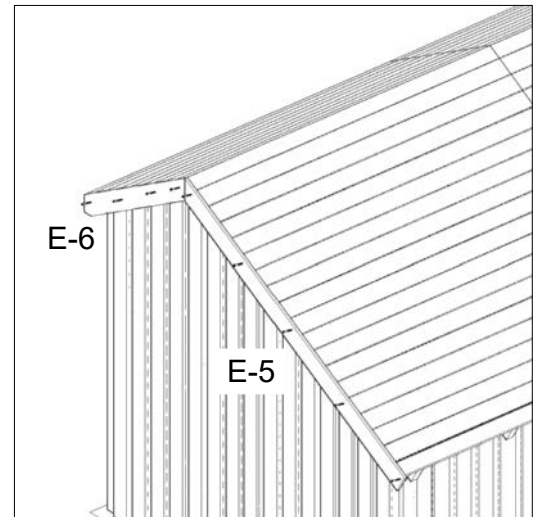
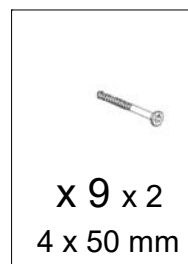

27

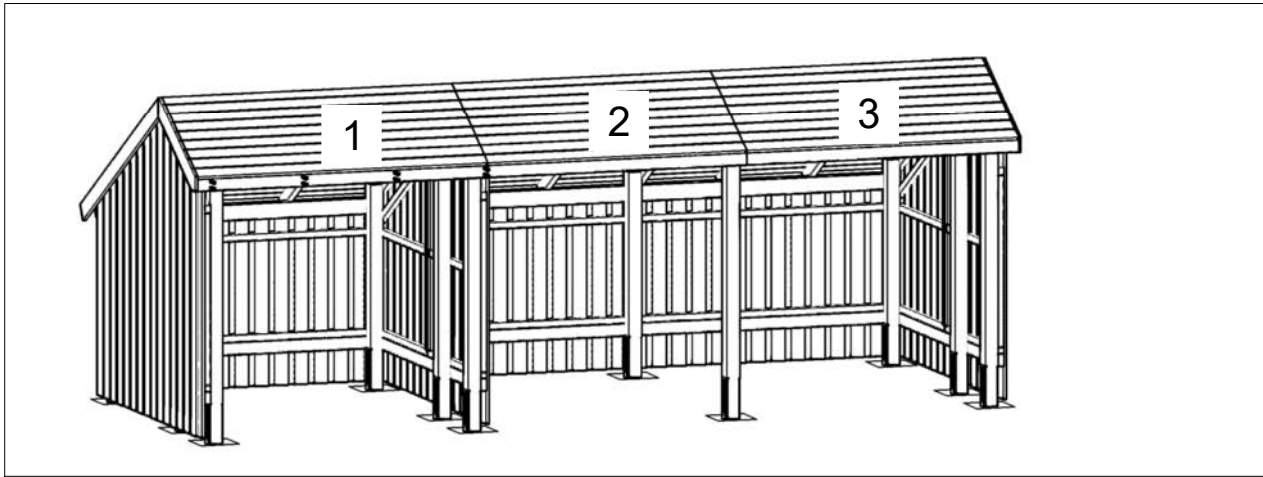

3 x E-7

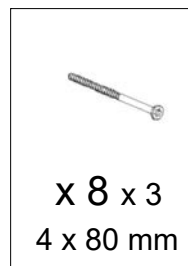
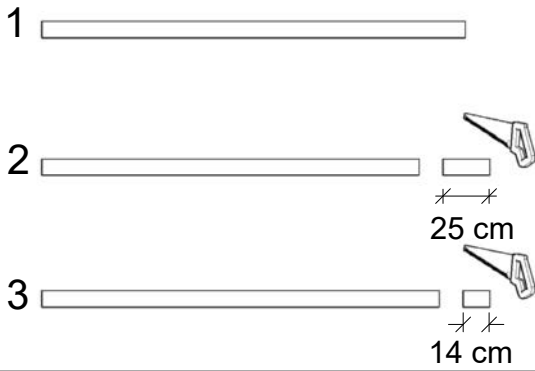

28

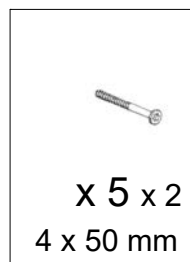
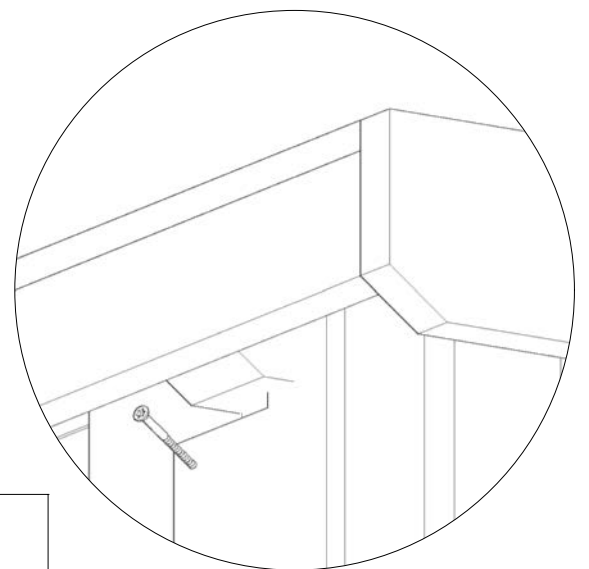
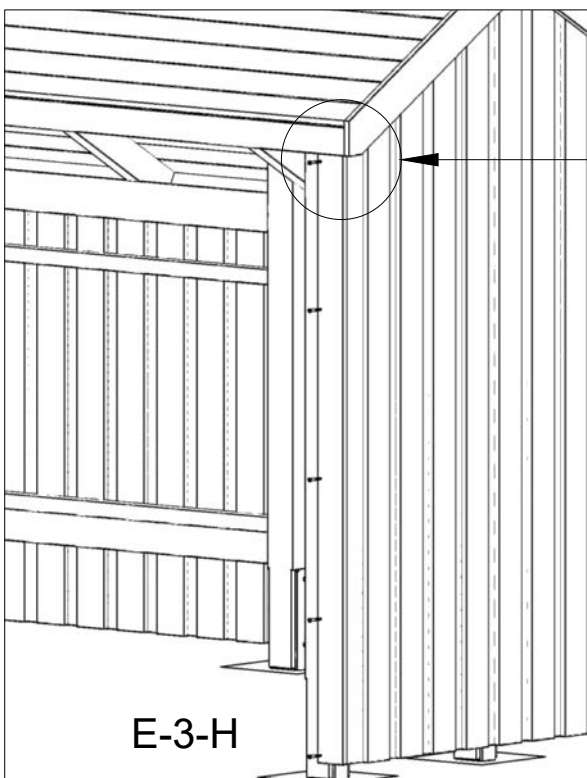

16752-1 167590-1 167591-1

Dørene er udadgående, kan vendes så den gående dør (G 1.1) vender enten til venstre eller højre.

Die Türen sind nach aussen aufgehend. Die Türen können getauscht werden, sodass die gehende Tür (G 1.1) sowohl rechts als auch links sitzt.

Dörrarna är utåtvända, kan vändas så att gångdörren (G 1.1) är vänd antingen åt vänster eller höger.

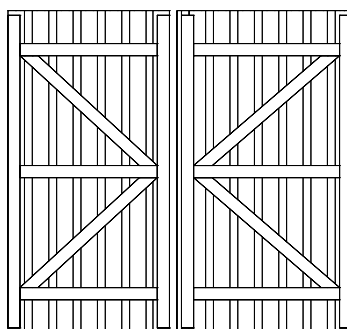
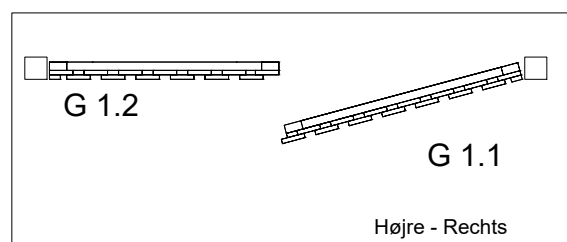
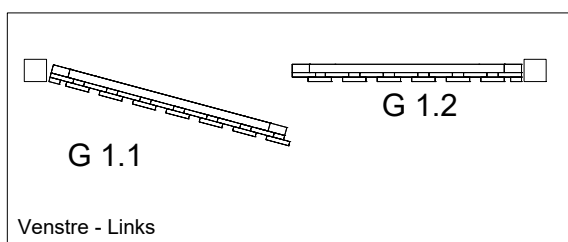

Dørenes indvendig side - Die Innenseite der Türen - Insidan av dörrarna

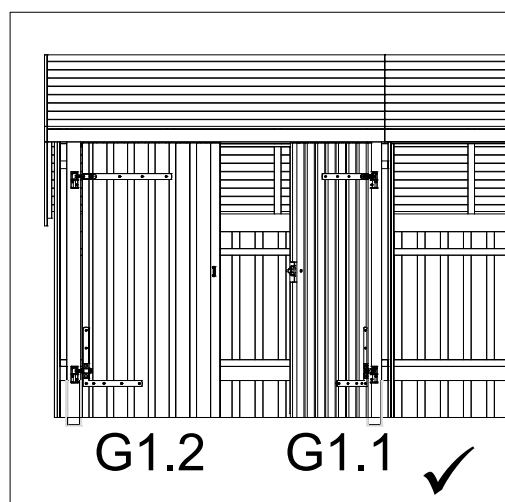
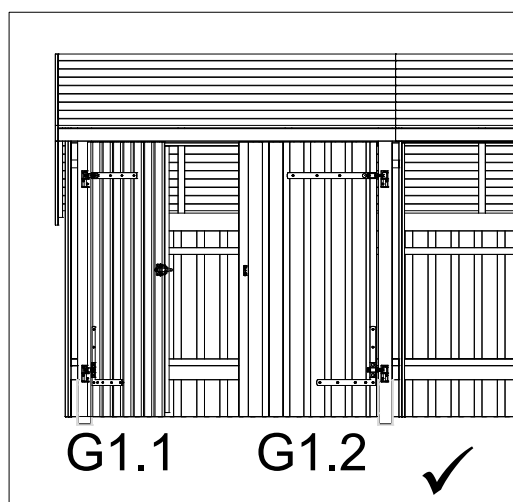

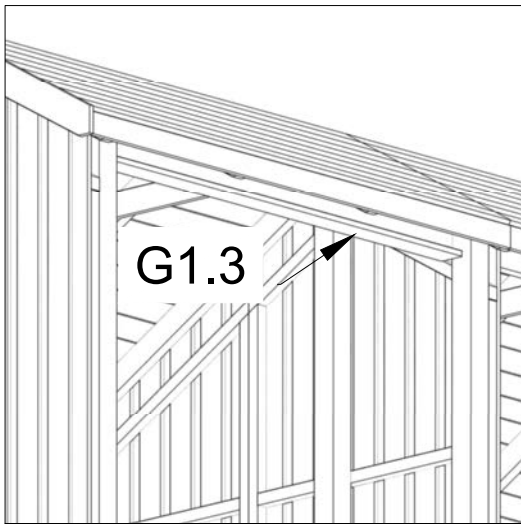

1

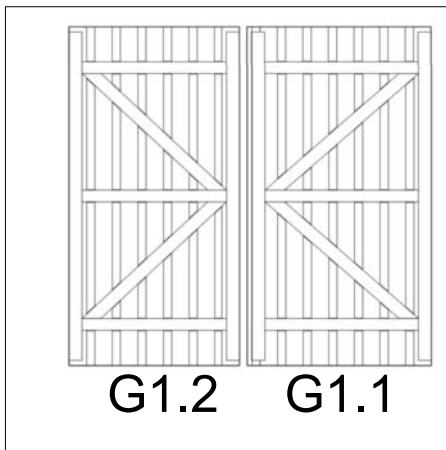
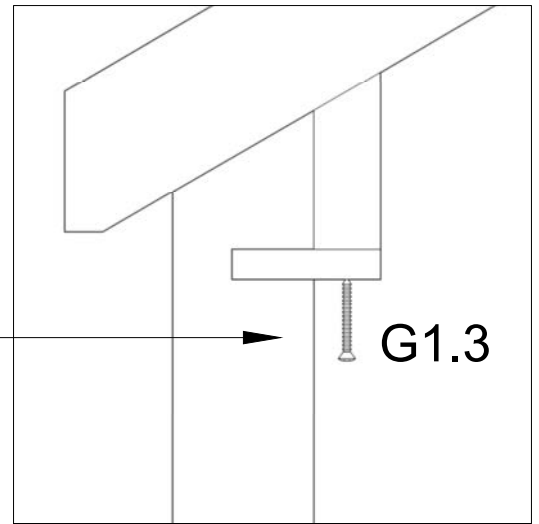
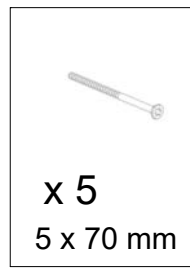

2

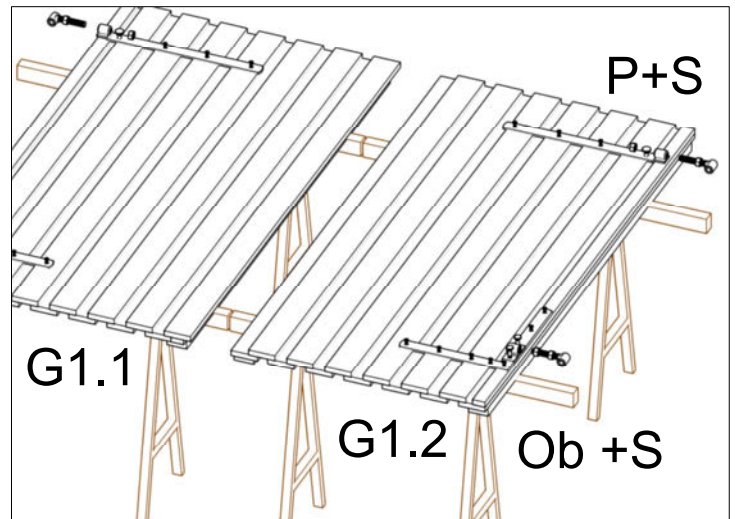
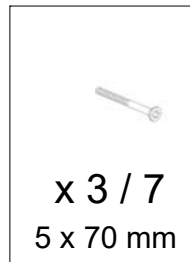

3

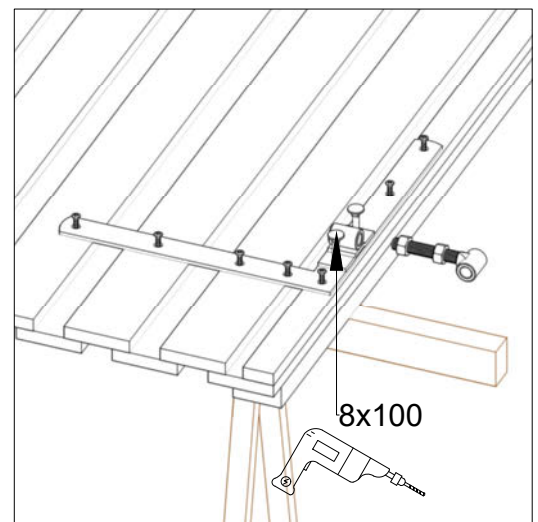
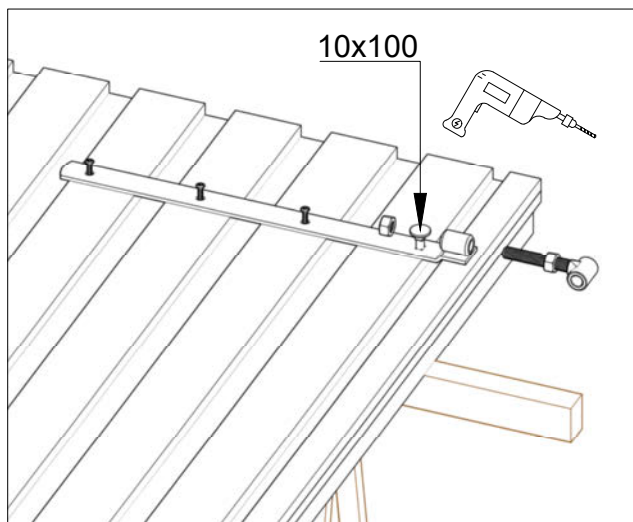

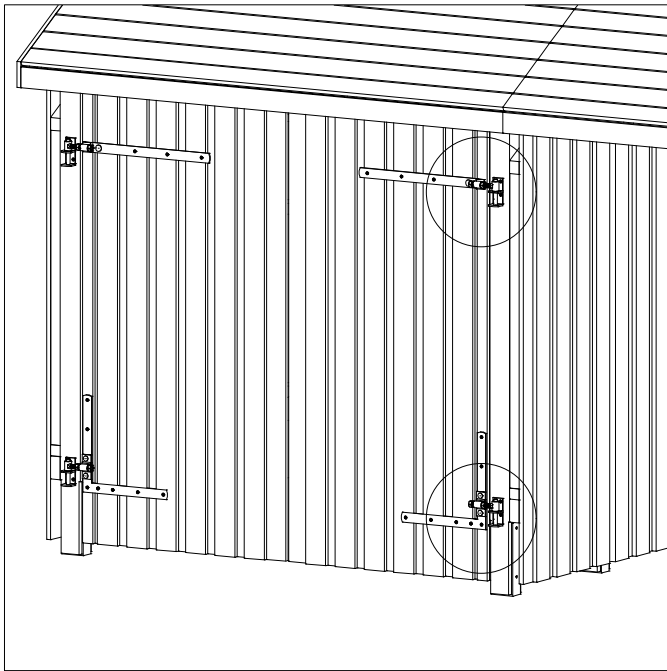

5

4

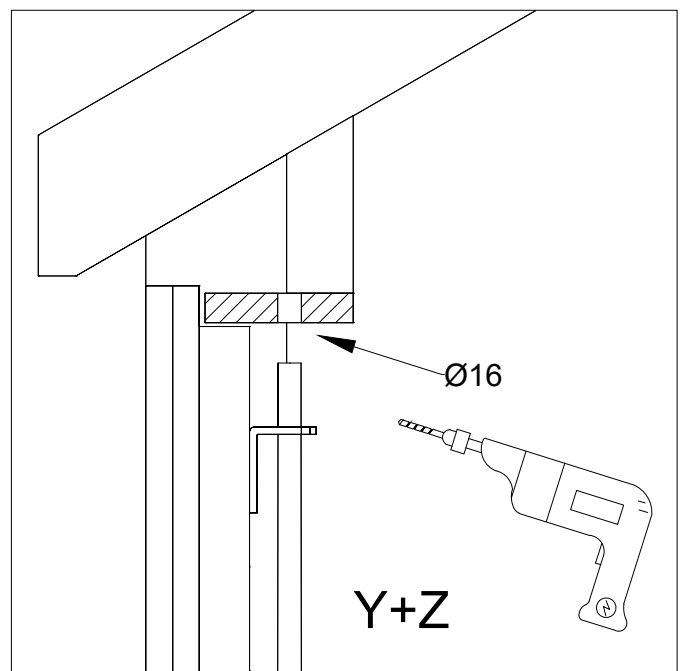
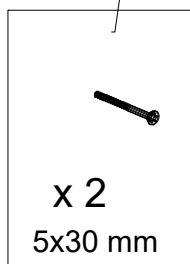
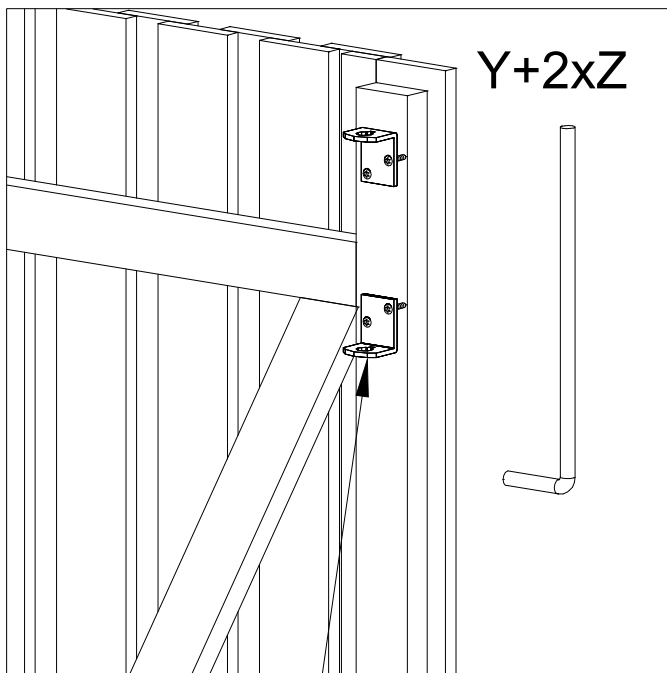
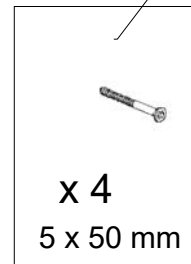
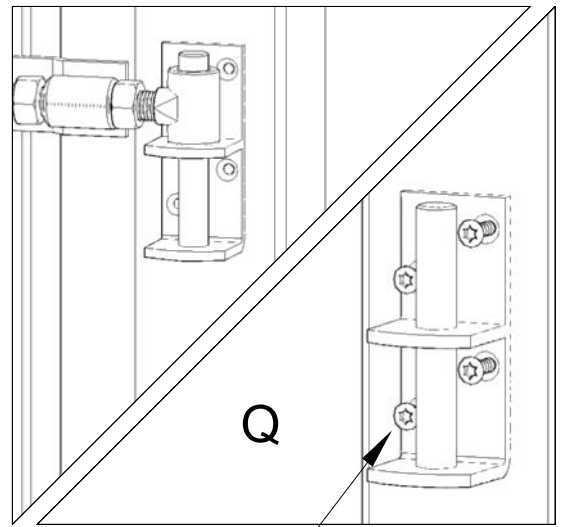

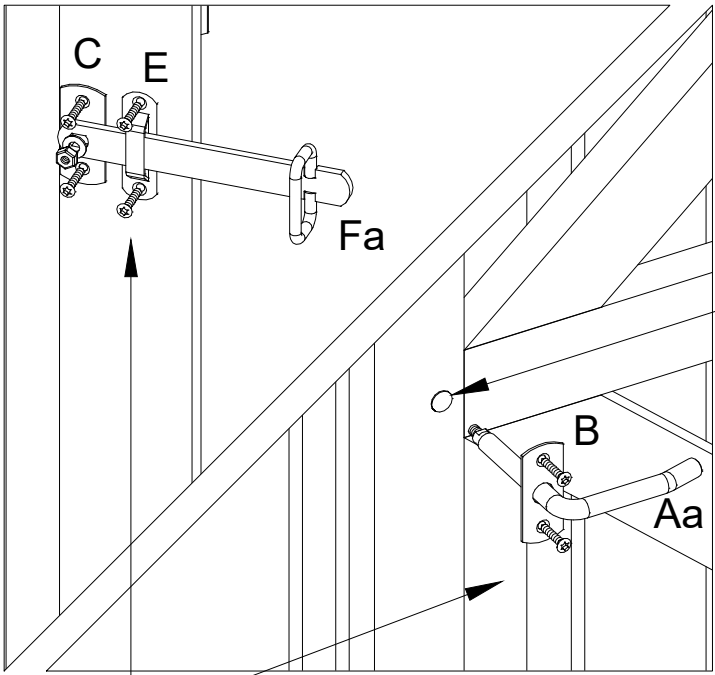

6

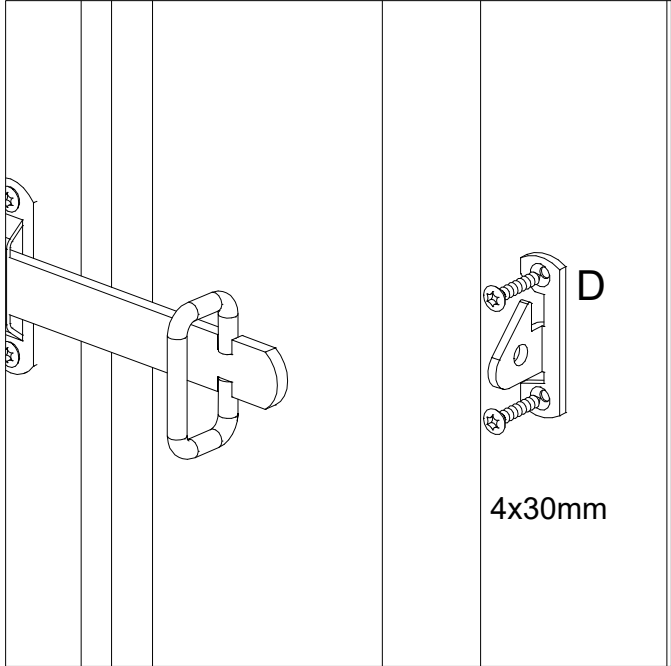
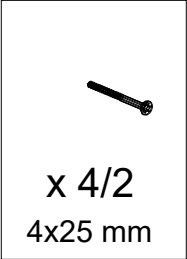
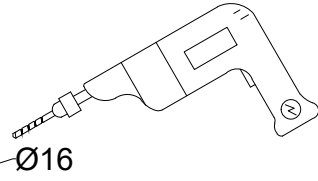

7

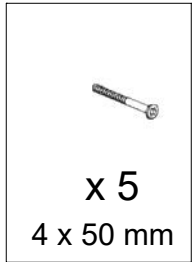
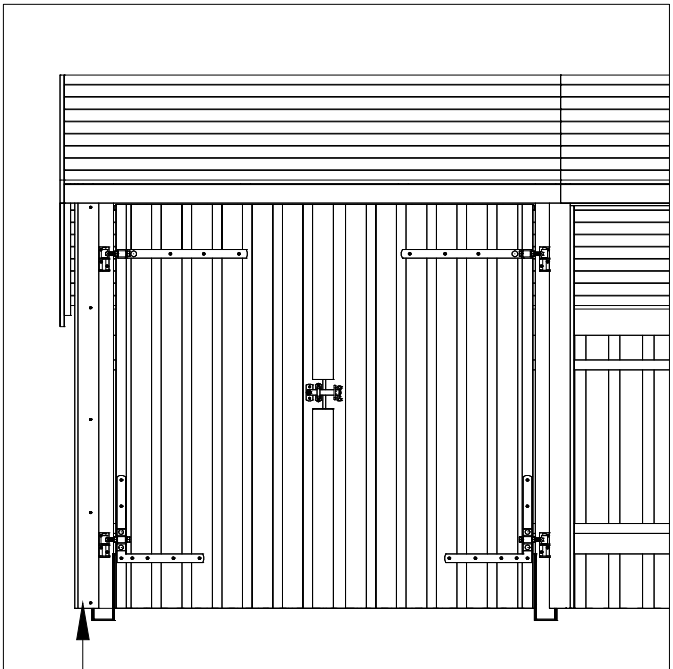

E-3 V

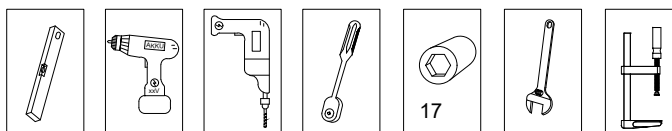

4839-1 / 19713-1

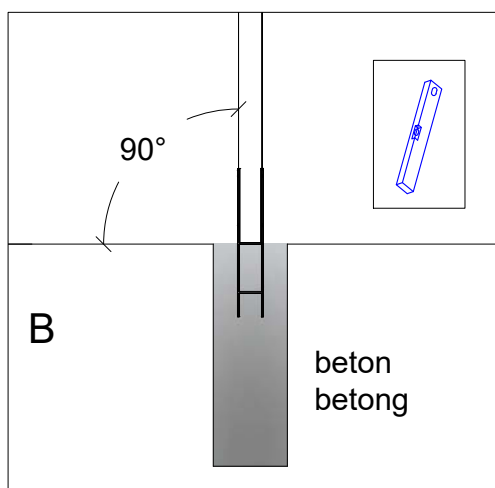
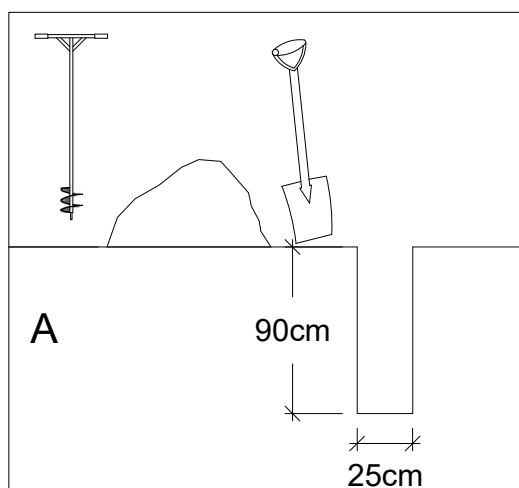
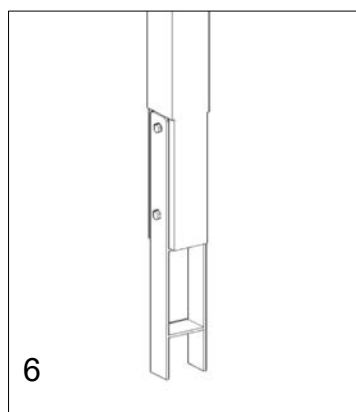
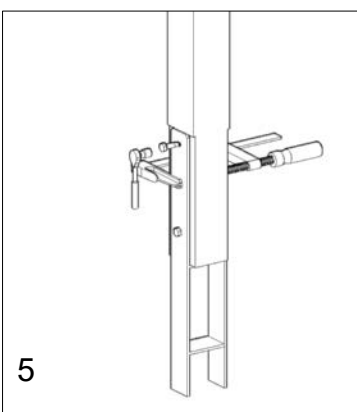
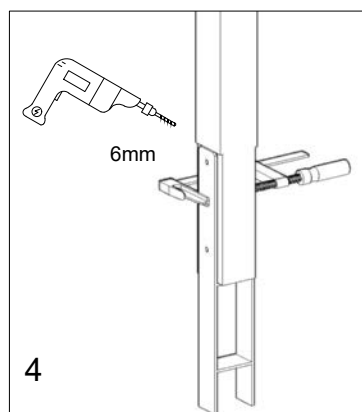
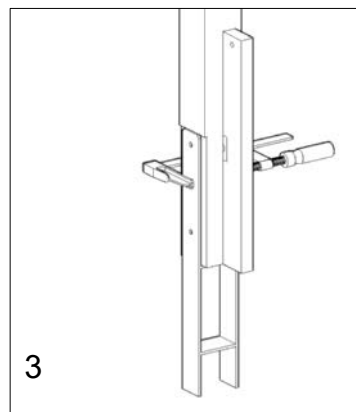
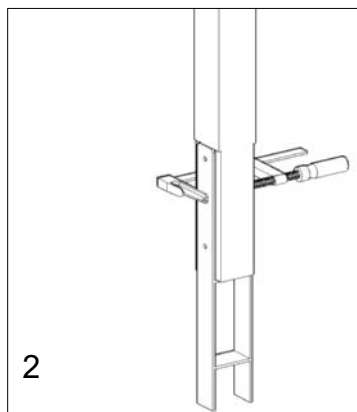
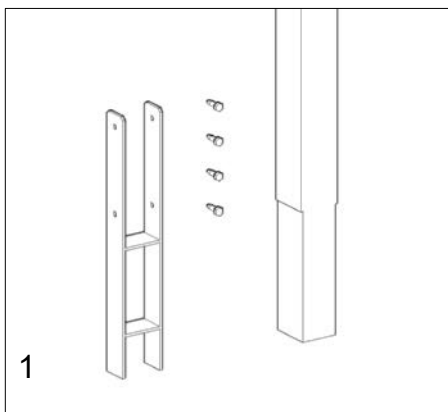

Viktig - at betonen omkring stolpen er hærdet op 3-5 dage før man fortsætter.

Es ist wichtig, dass der Beton um den Pfosten 3 bis 5 Tage aushärtet, bevor man mit der Montage fortfährt.

Viktigt - att betongen runt stolpen hårdas 3-5 dagar innan du fortsätter med installationen.

PLUS A/S
 Ådalen 13B
 DK-6600 Vejen
 phone: +45 7996 3333
 web: www.plus.dk

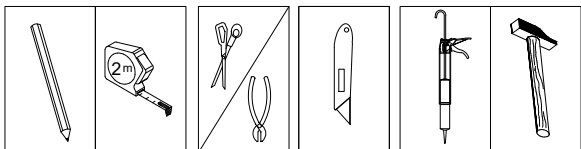

PLUS

PLUS A/S

Ådalen 13B

DK-6600 Vejen

phone: +45 7996 3333

web: www.plus.dk

(Vnr. 177025)



5 703393 740724

A

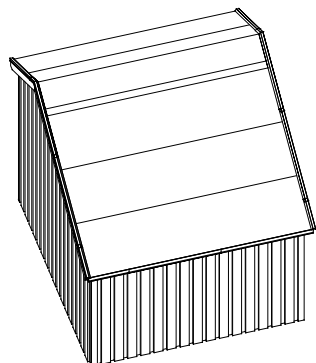

167565-1 / 167566-1 / 1675605-1 / 1675606-1

B

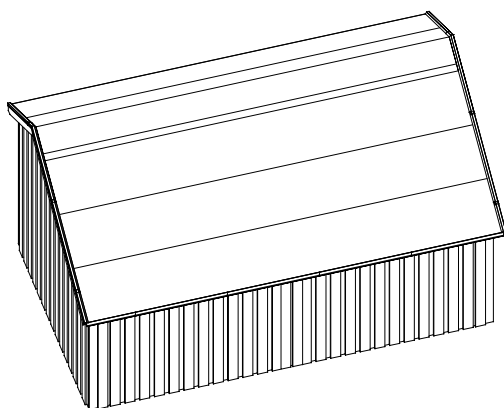

167585-1 / 167586-1 / 1675805-1 / 1675806-1 /
1675815-1 / 1675816-1 / 1675825-1 / 1675826-1 /

C

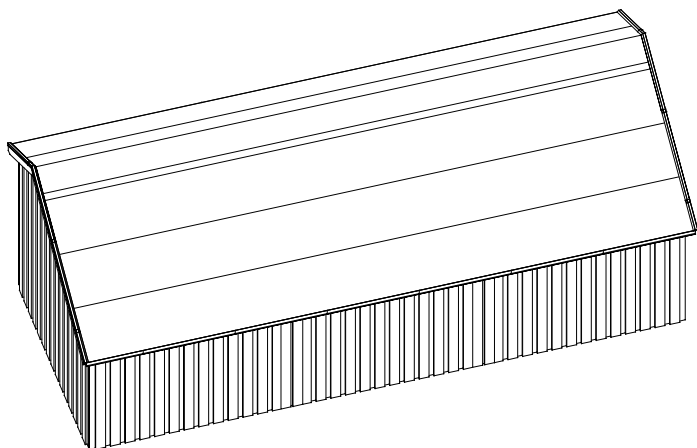

1675905-1 / 1675906-1 / 1675915-1 / 1675916-1

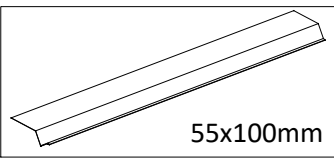
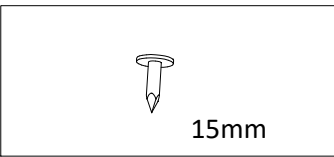
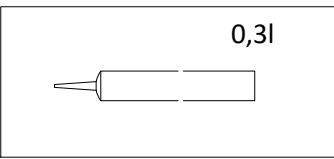
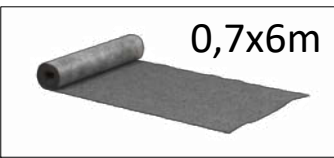
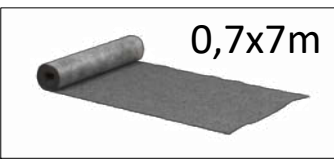
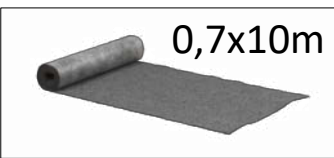
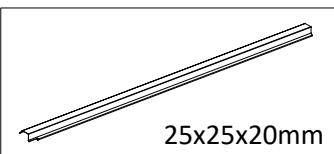
	A	B	C
 <p>55x100mm</p>	6 stk	10 stk	14 stk
 <p>15mm</p>	400 stk	700 stk	800 stk
 <p>0,3l</p>	1 stk	2 stk	2 stk
 <p>0,7x6m</p>	3 stk		
 <p>0,7x7m</p>			6 stk
 <p>0,7x10m</p>		3 stk	
 <p>25x25x20mm</p>	7 stk	7 stk	7 stk

Sternebrædder i siden , monteres som på tegning.
Sternbretter an den Seiten, Montage lt. Zeichnung.

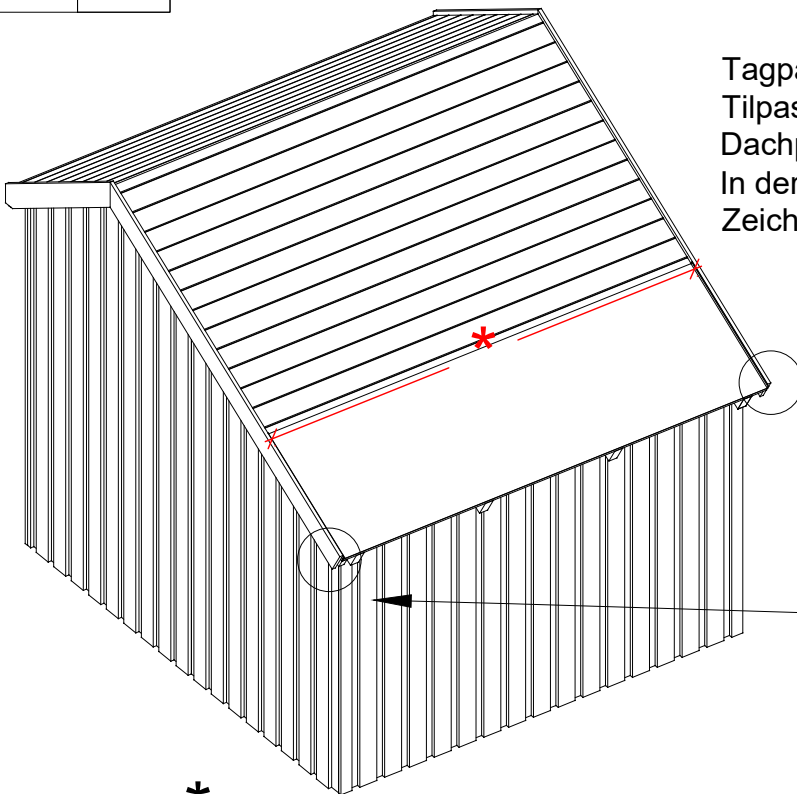
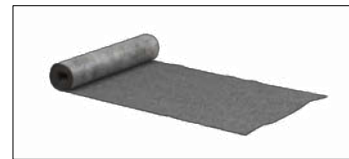
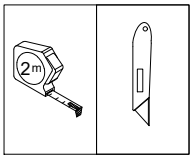
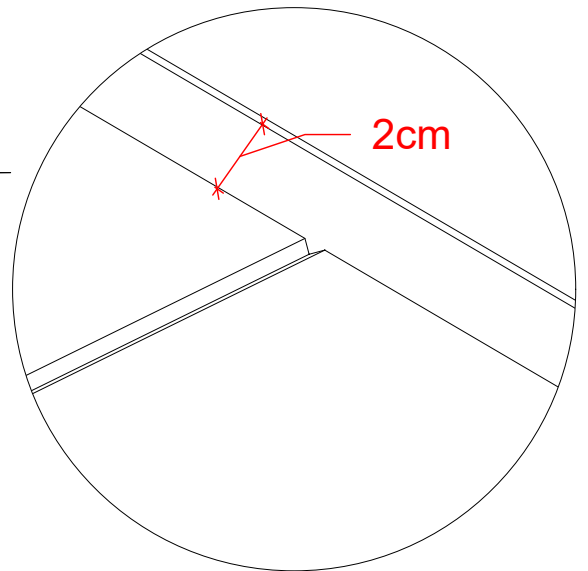
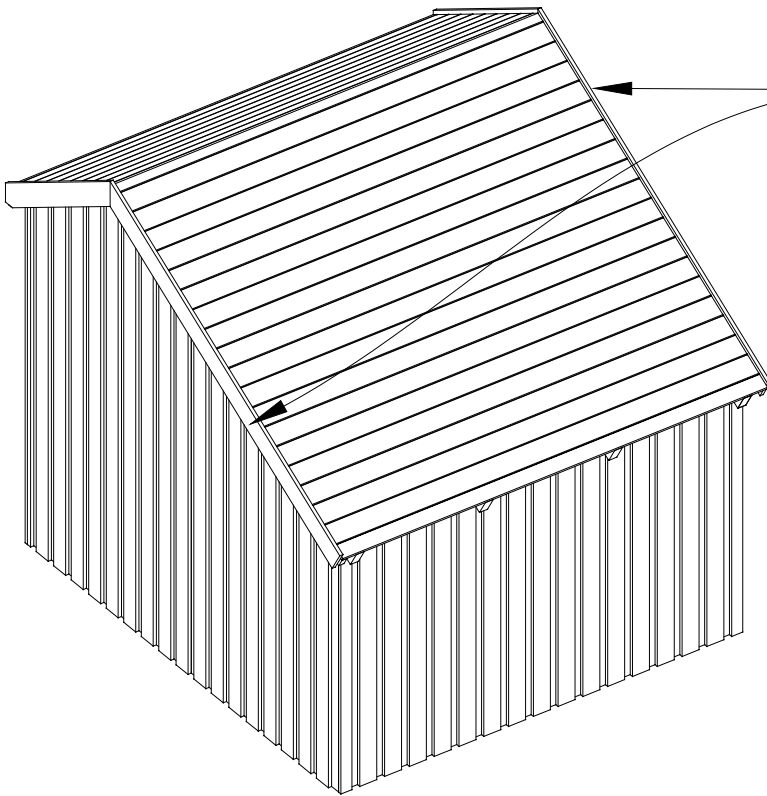

Tagpap:
Tilpasses i længden, 6 stk tagpap som tegning.
Dachpappe:
In der Länge anpassen, 6 Stck. Dachpappe lt.
Zeichnung

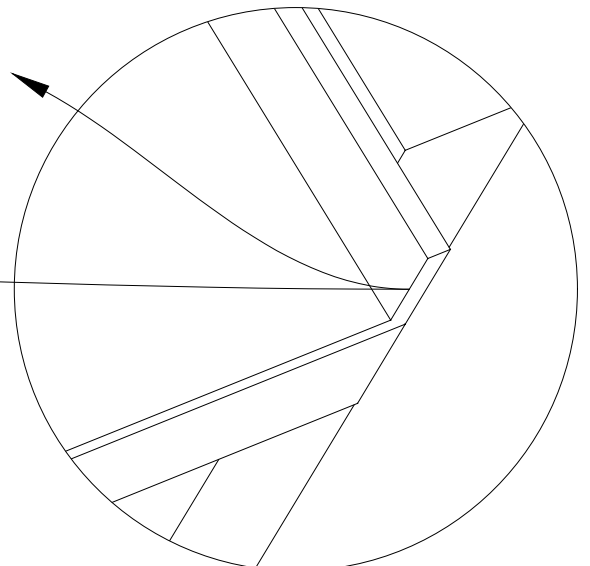

*

ca 2cm + Taglængde + ca 2 cm
ca 2cm + Dachlänge + ca 2 cm

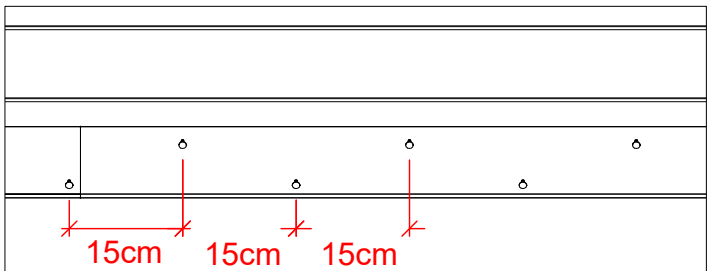
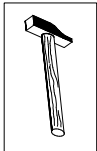
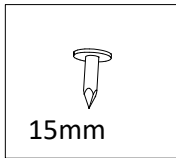
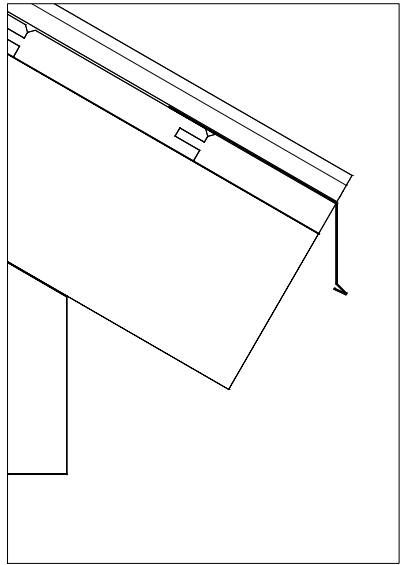
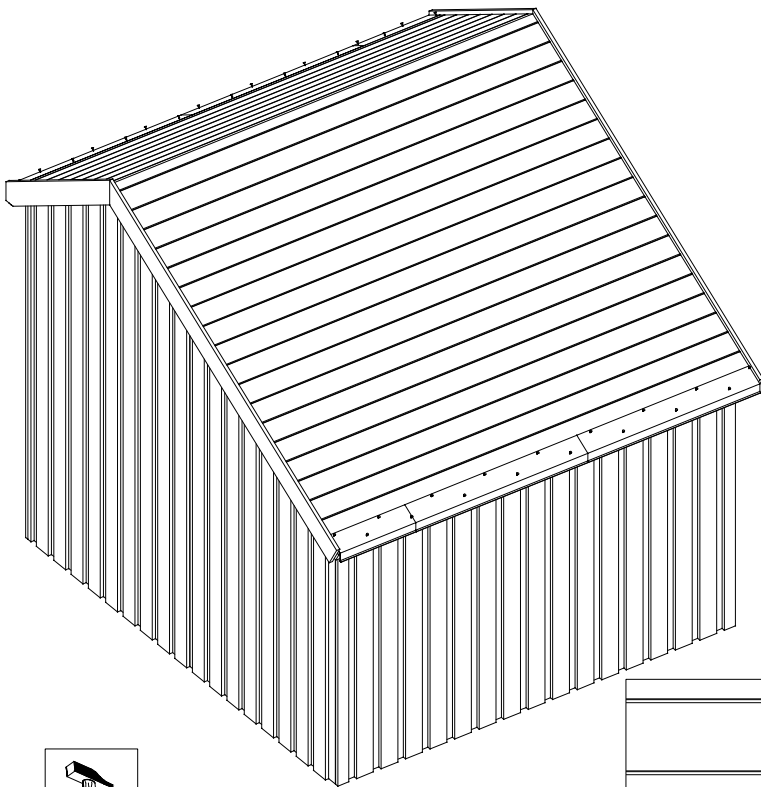
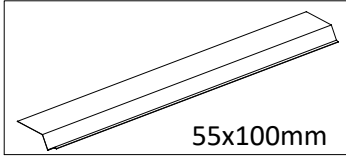
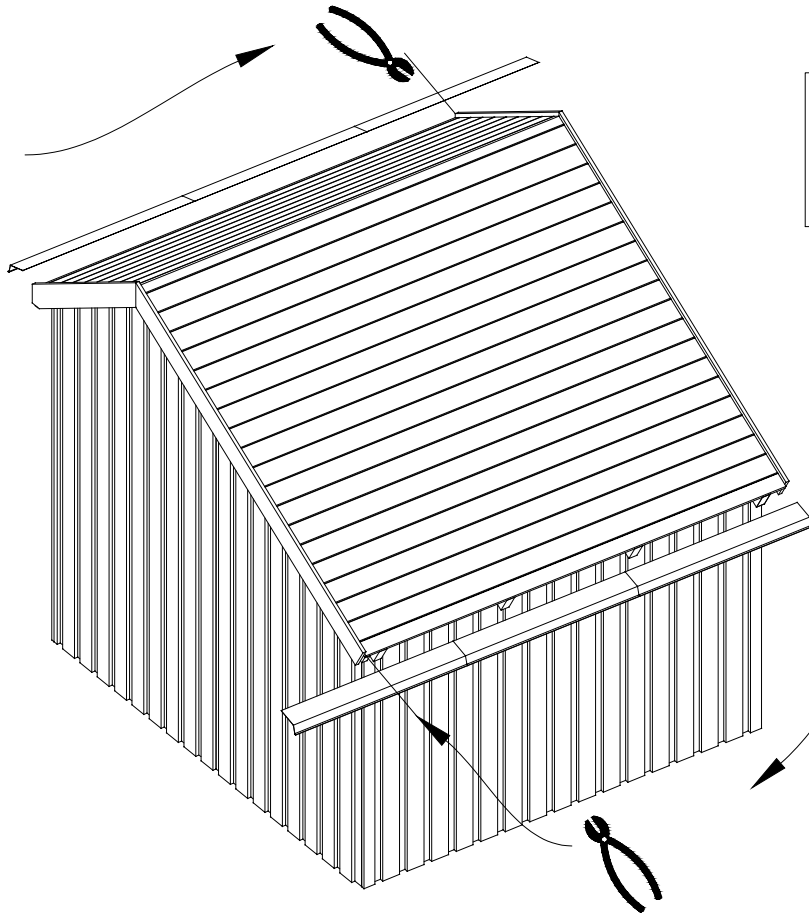

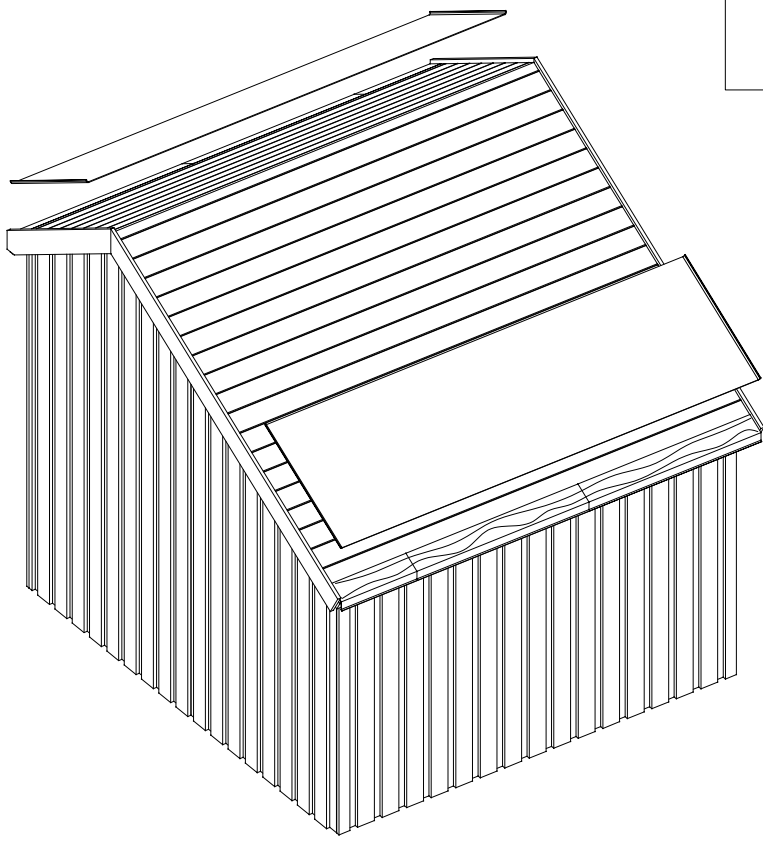
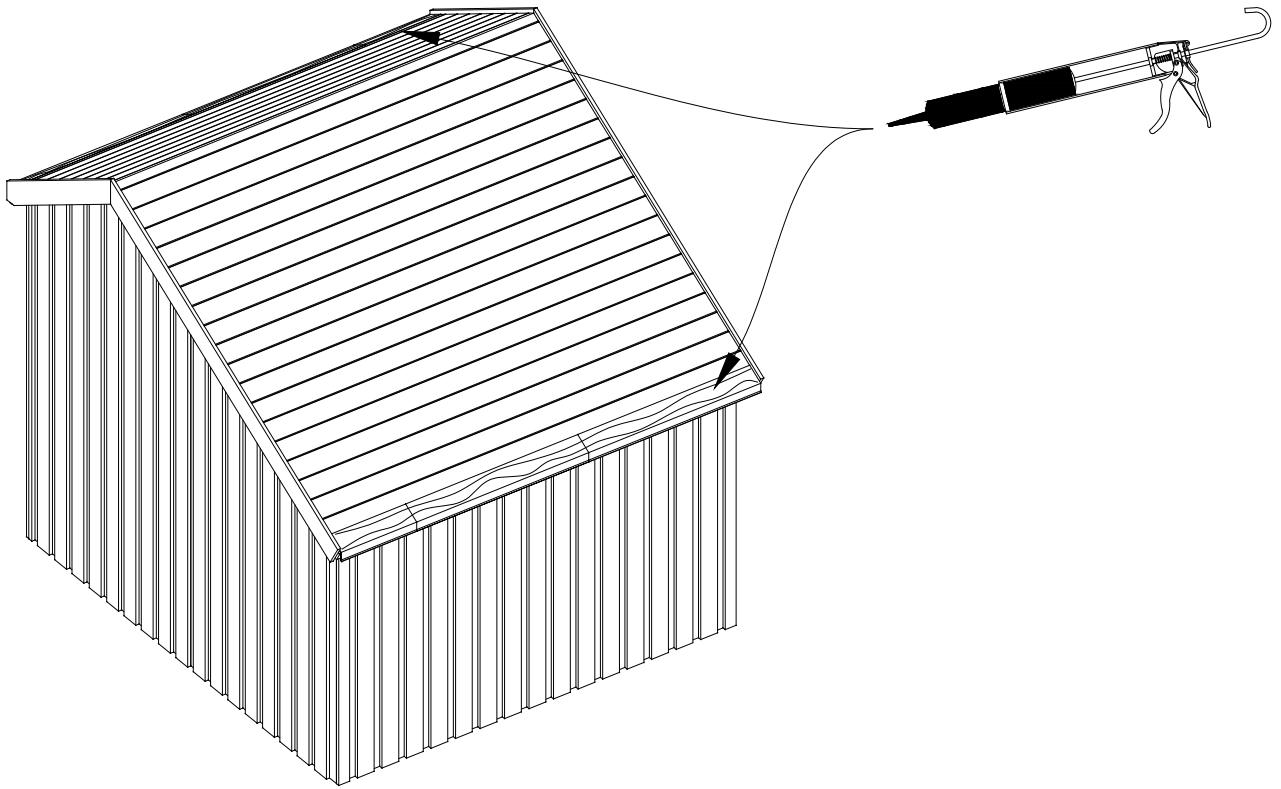

x 2

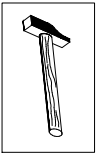
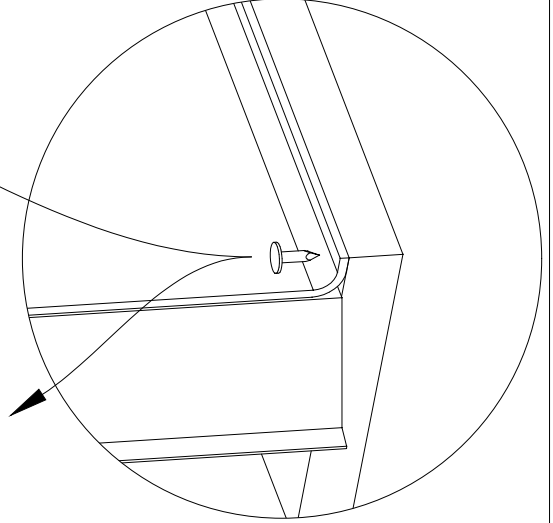
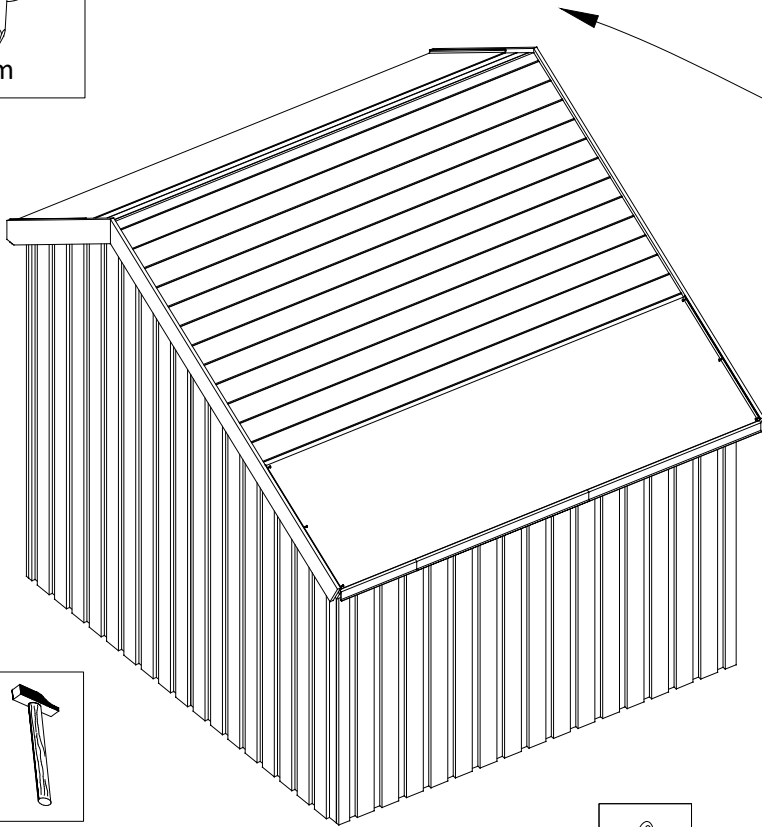
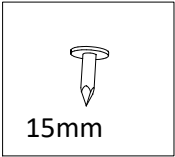

x 3

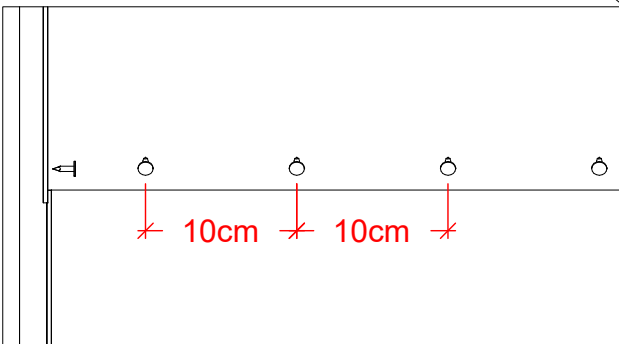
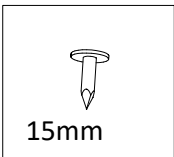
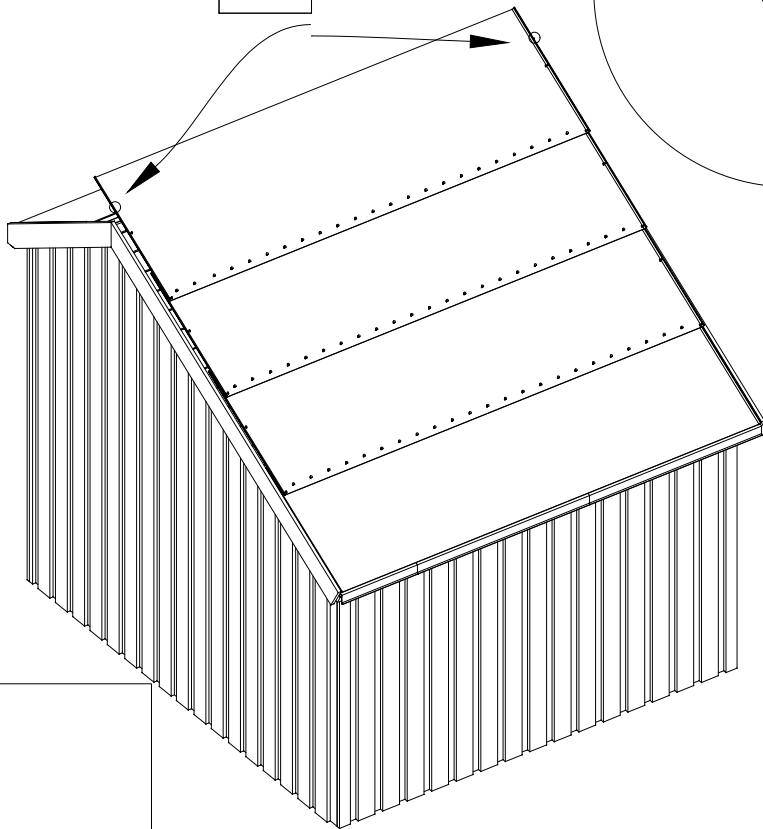
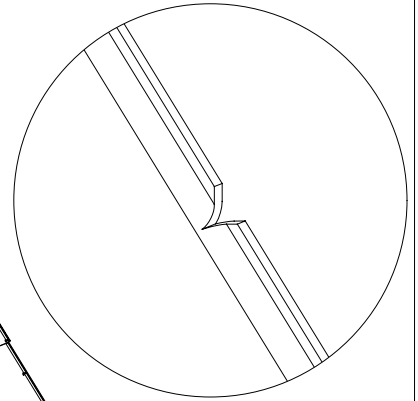
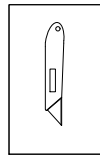



x 1

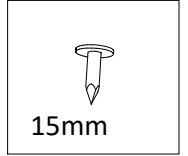
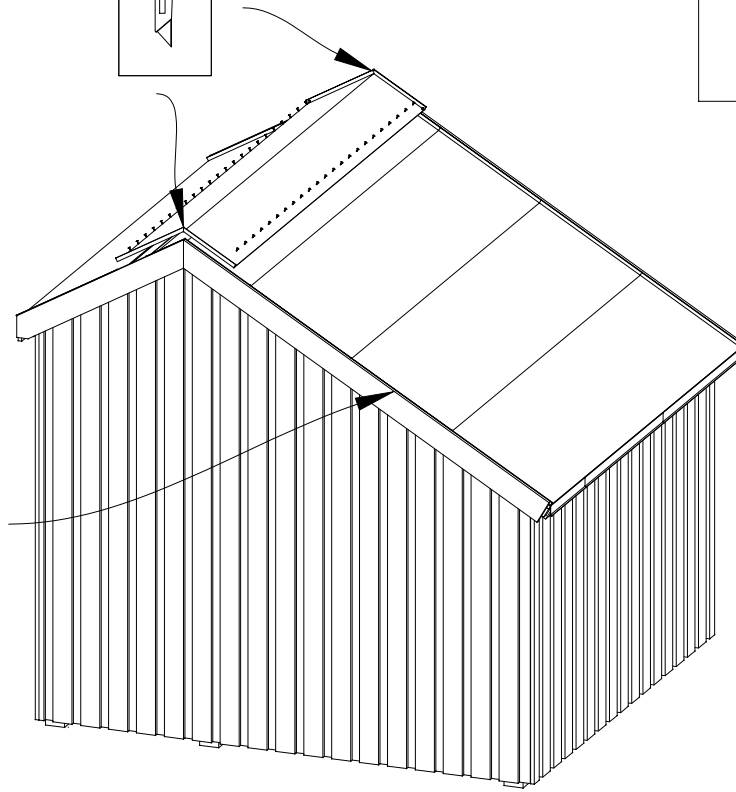
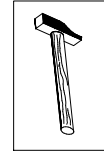
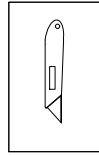
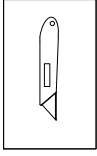

15mm

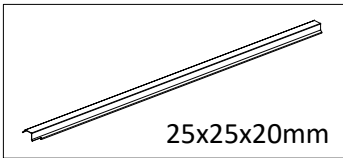

25x25x20mm

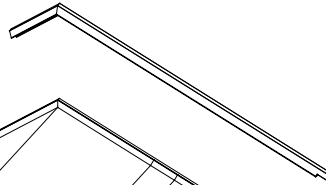
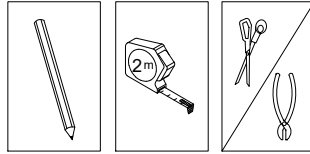

H

V

