

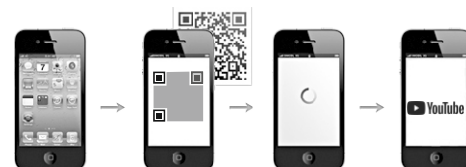

- | | | |
|---|--|--|
| (D) Videounterstützte Montageanleitung | (GB) Video-assisted assembly instructions | (FR) Instructions de montage assistées par vidéo |
| (TR) Video destekli kurulum talimatları | (IT) Istruzioni di montaggio video-assistite | (NL) Video-ondersteunde montage-instructies |
| (RU) инструкция по монтажу с помощью видеосигнала | (CZ) Instalační pokyny podporované videem | (HU) Video-támogatott telepítési utasítások |
| (RO) Instrucțiuni de instalare acceptate video | (PL) Instrukcje montażu wspomagane sygnałem wizyjnym | (SK) Inštaláčne pokyny podporované videom |

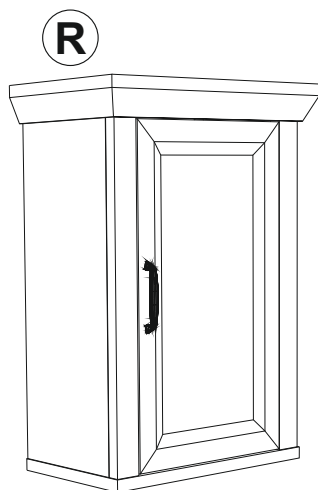
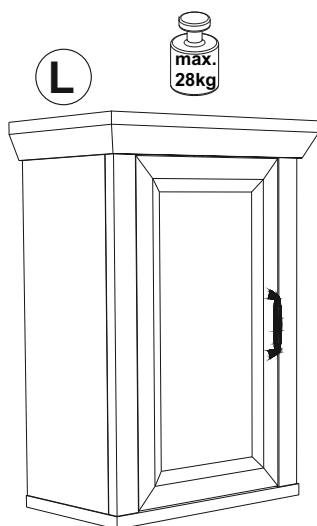

Art.-Nr. : **0101-HS_1**
Hängeschrank

REPC-Nr.:



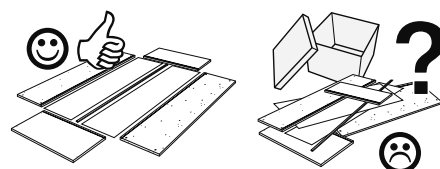
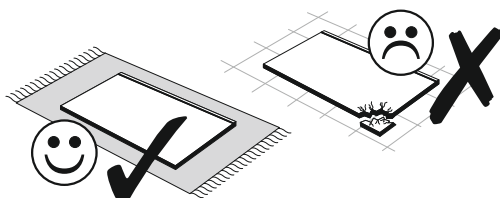
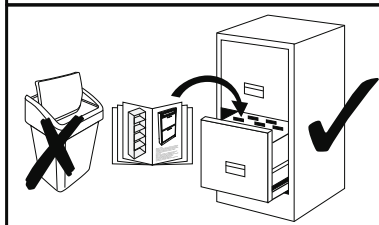
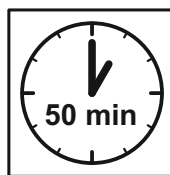
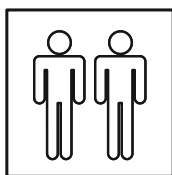
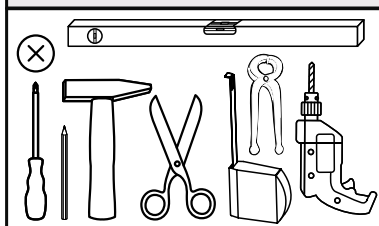







**Service • Assistenza • Dienstverlening • Serwis
Servis • Szerviz • Сервисная служба**

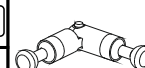

SCAN ME

Das Ersatzteil-Anforderungsformular finden Sie auf
The replacement parts requisition form you find on
<https://www.maeusbacher.de/ersatzteile/>

BT1-00286 Colli 1/1

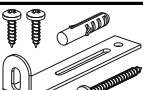
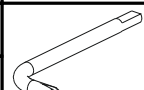
B02-10 18x  ø15x12mm	B02-20 14x 	B01-90 8x  3,5x20	B02-27 2x 	B02-90 2x  6x30
B01-80 4x  3,5x13	B01-206 2x  6,3x22	B01-327 2x  M4x19	B08-40 2x  5,8x65	B08-70 2x  ø8mm
B02-160 8x 	B08-80 1x 	B01-244 1x 		





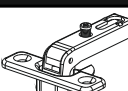
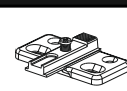

▶ SCAN ME

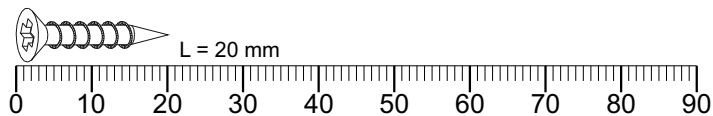
BT1-00287 Colli 1/1

B03-44 2x 	B03-44 2x 
---	---

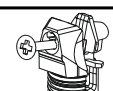

BT1-00288 Colli 1/1

B05-130 1x 	B05-185 4x 	B06-192 1x 	B06-500 1x 
--	--	--	--

Colli 1/1

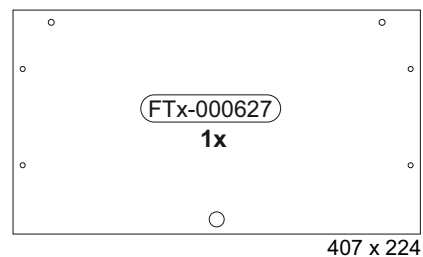
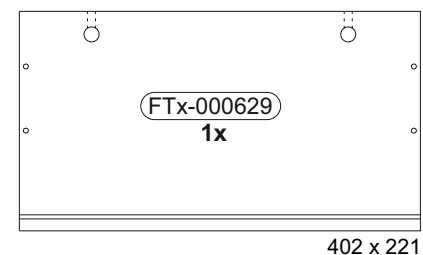
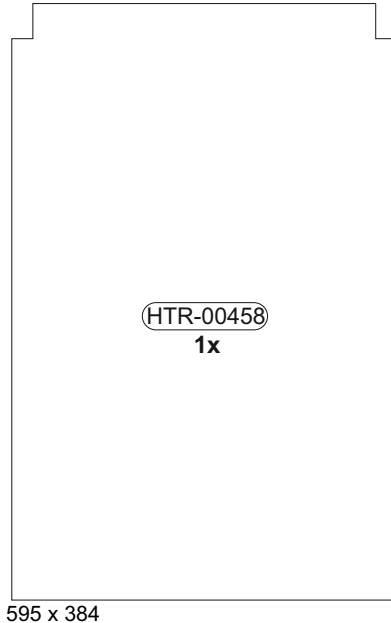
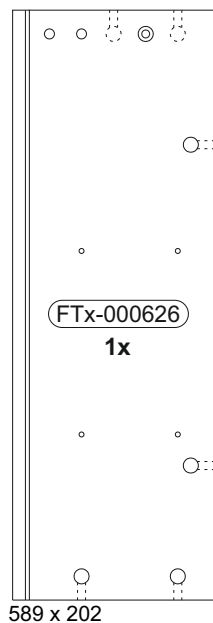
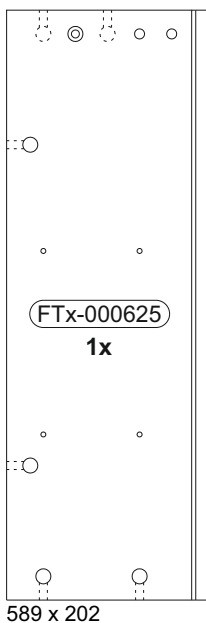
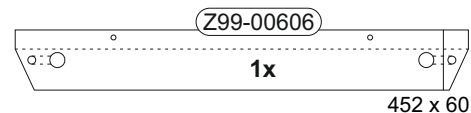
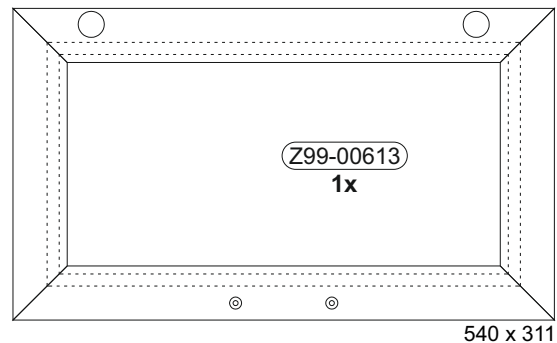
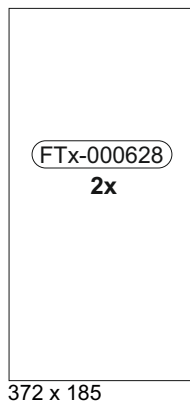
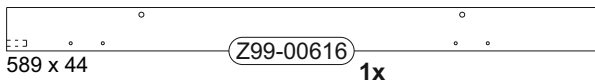
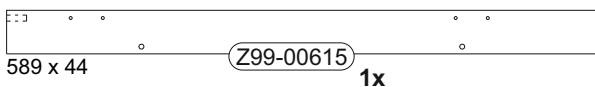
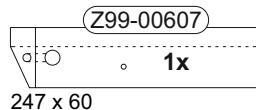
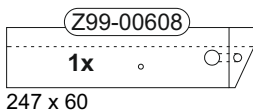
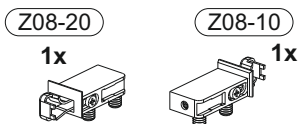

1

	B02-10		B02-20		B05-130		B02-27	
	4x	ø15x12mm	2x		1x		2x	



▶ SCAN ME

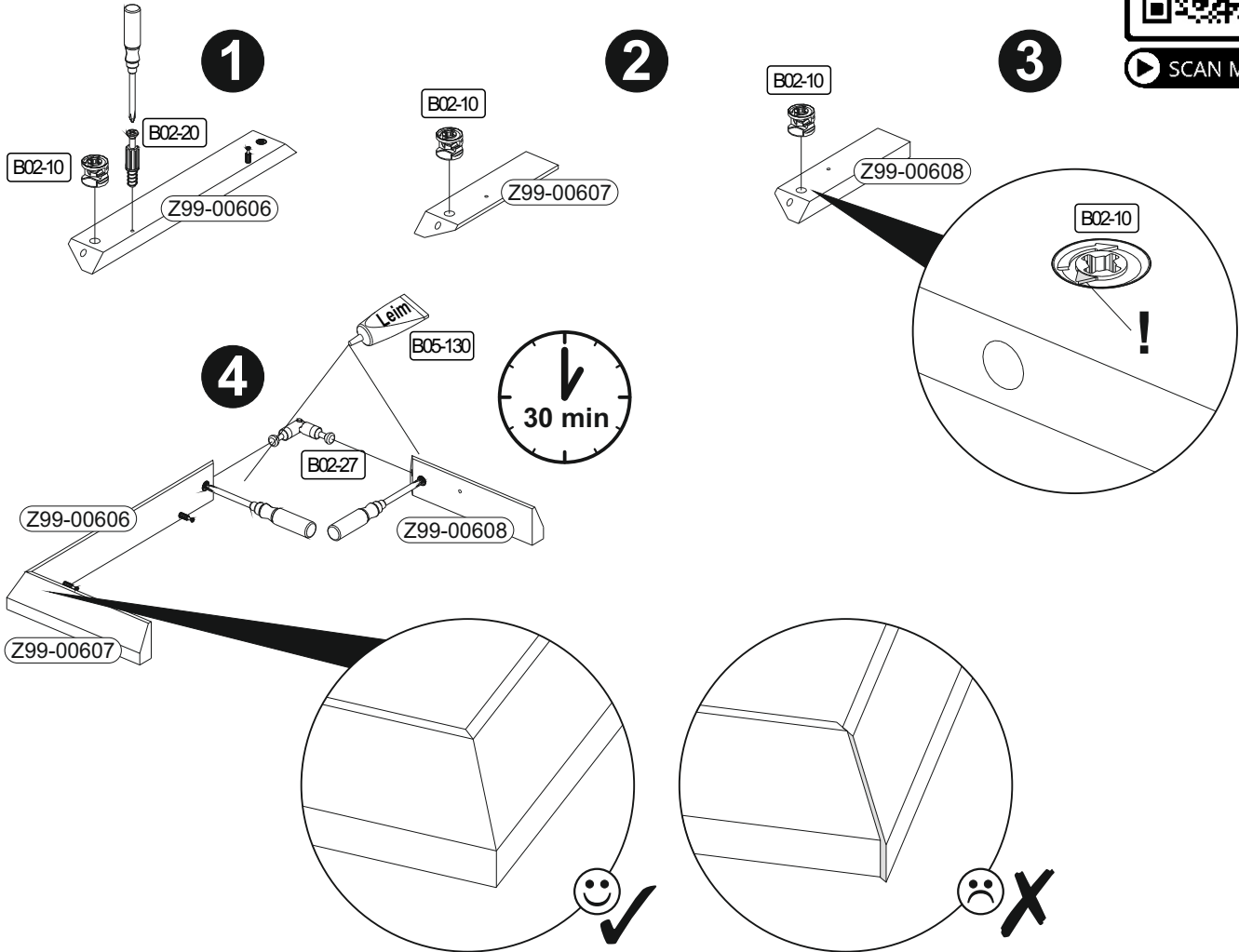

2

	B02-10		B02-20		B05-192	
	2x	ø15x12mm	8x		1x	

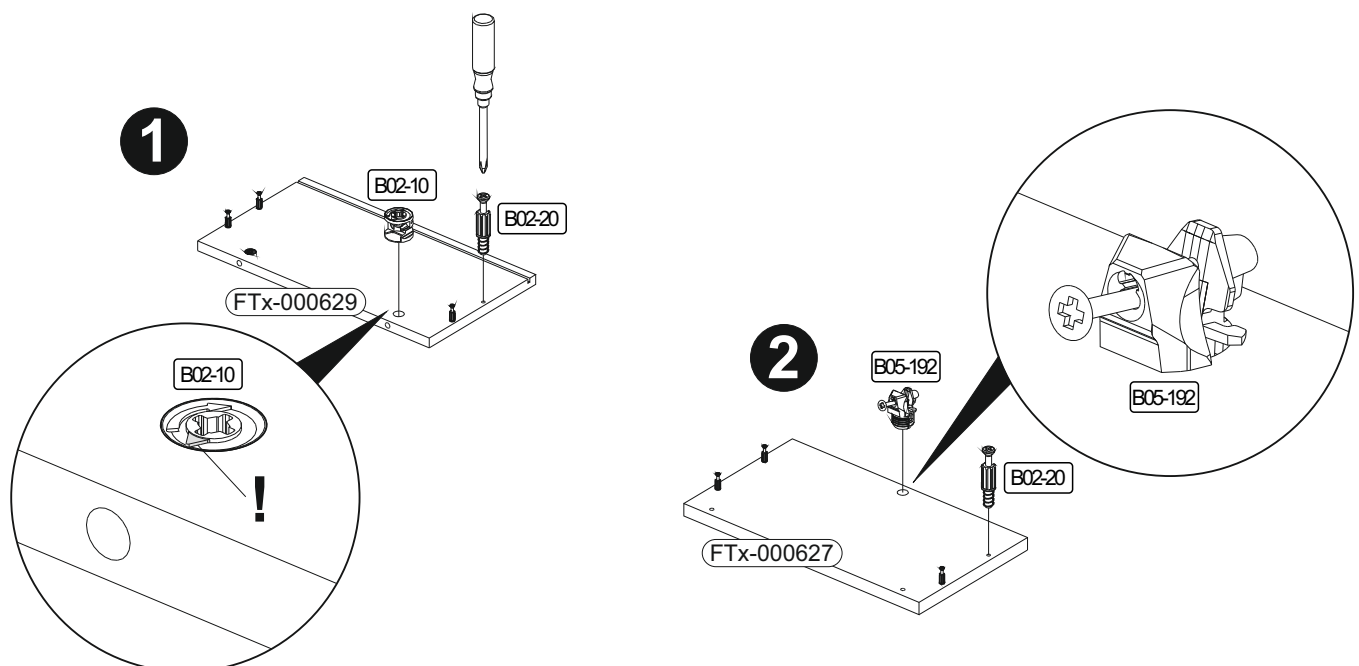

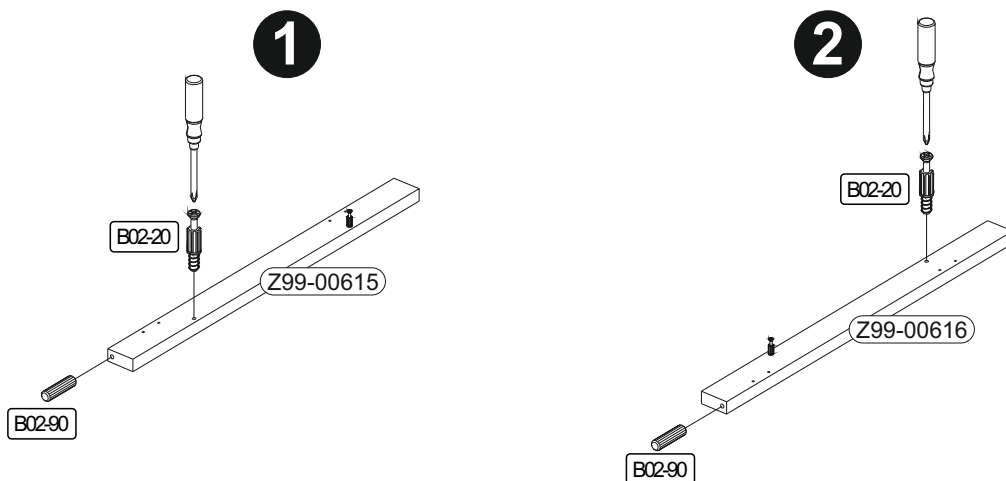
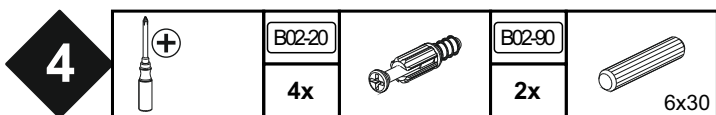
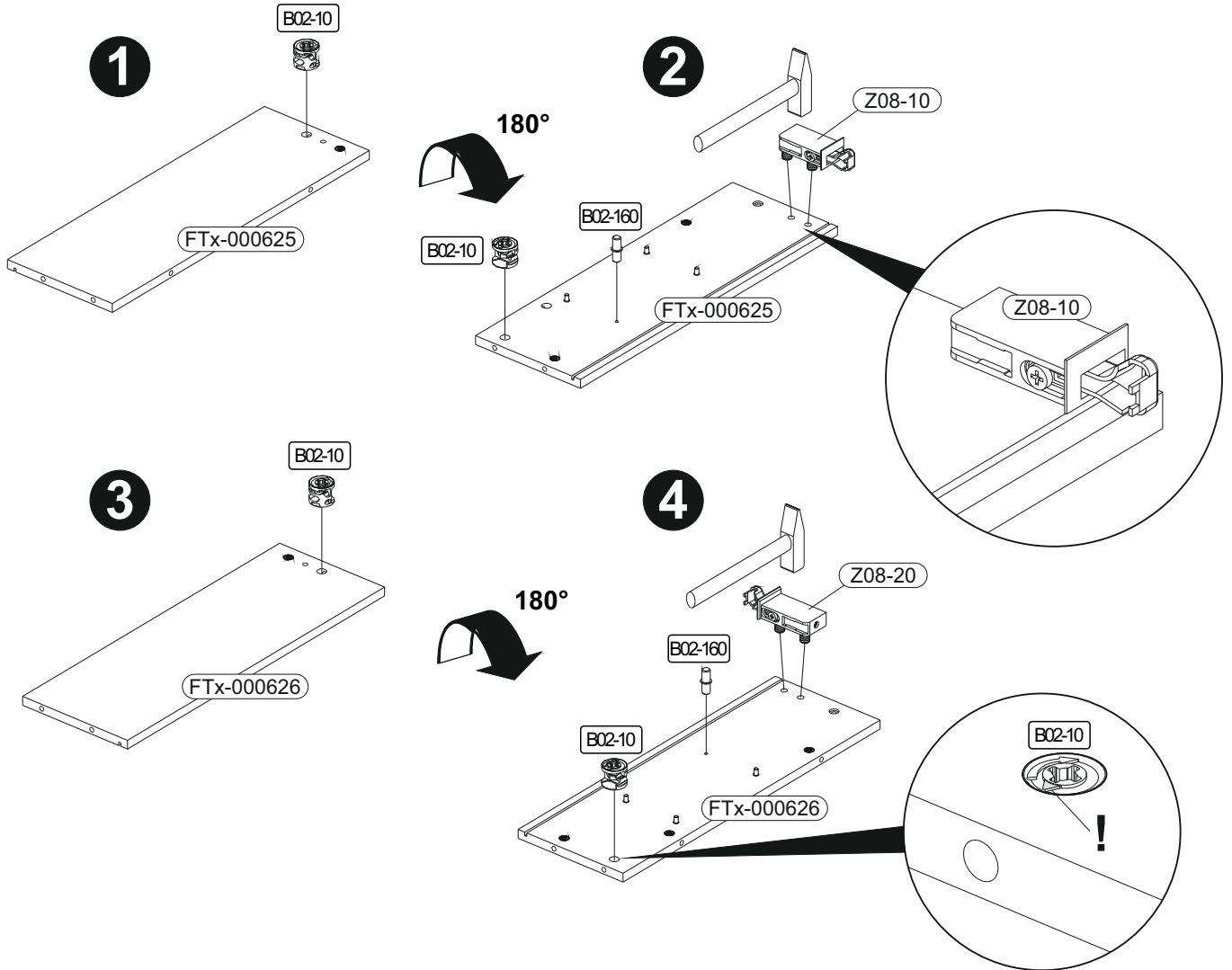
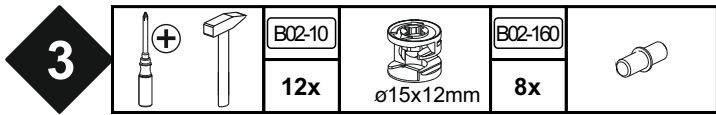

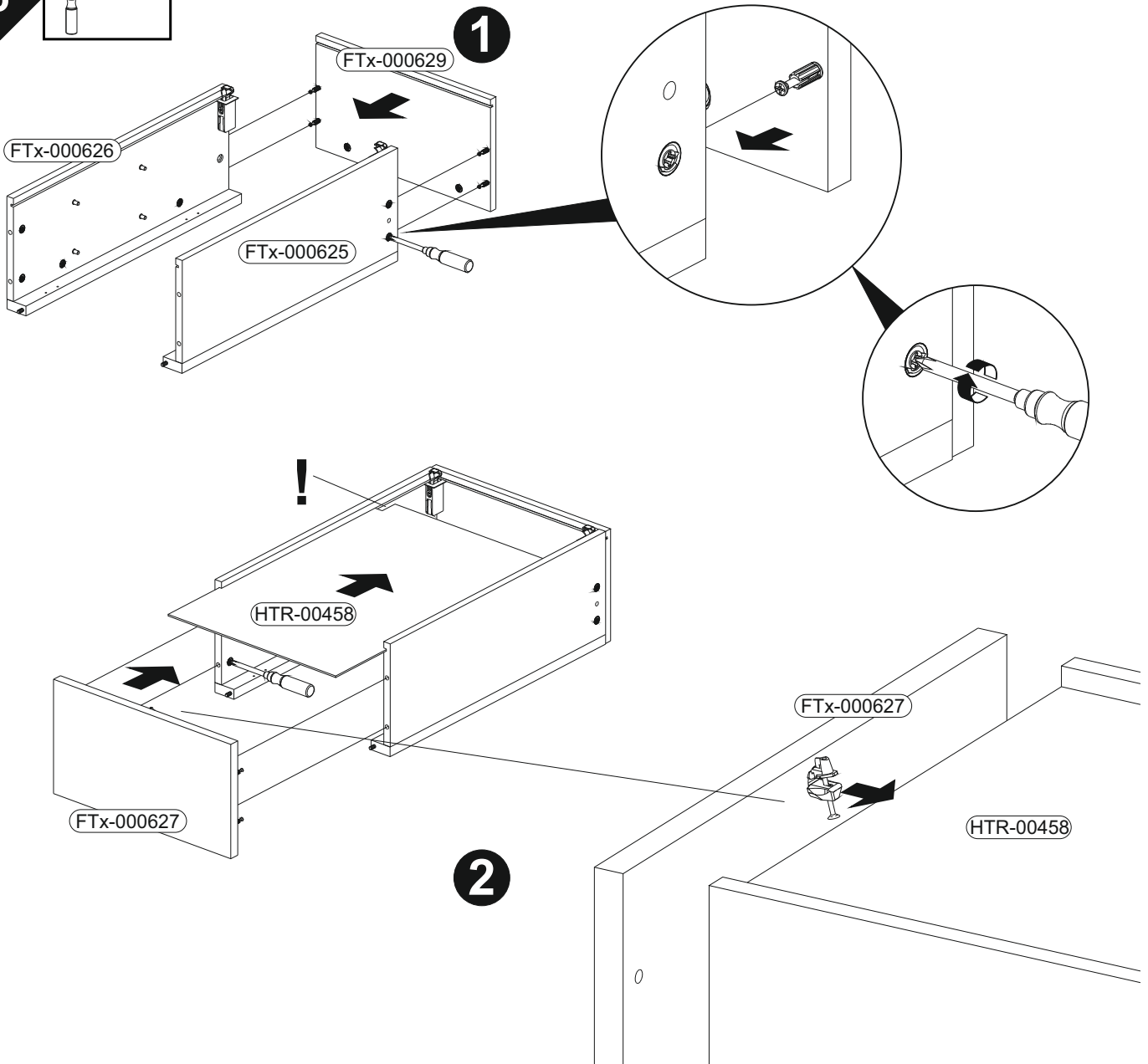
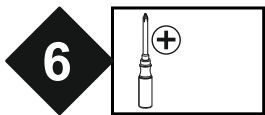
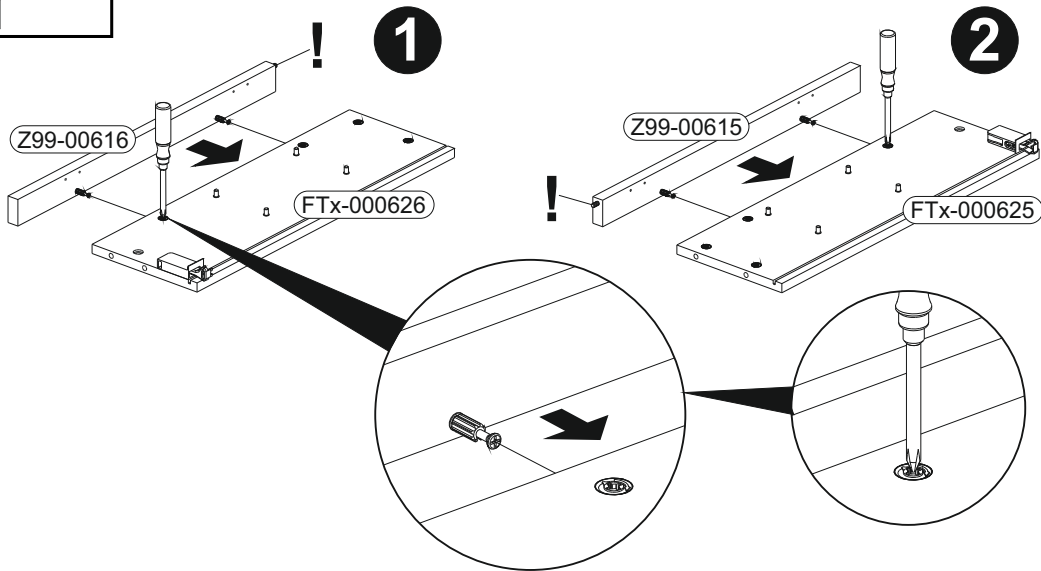
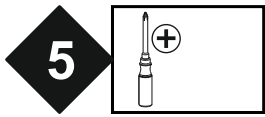

7

	B05-185		B01-90	
	4x		4x	3,5x20

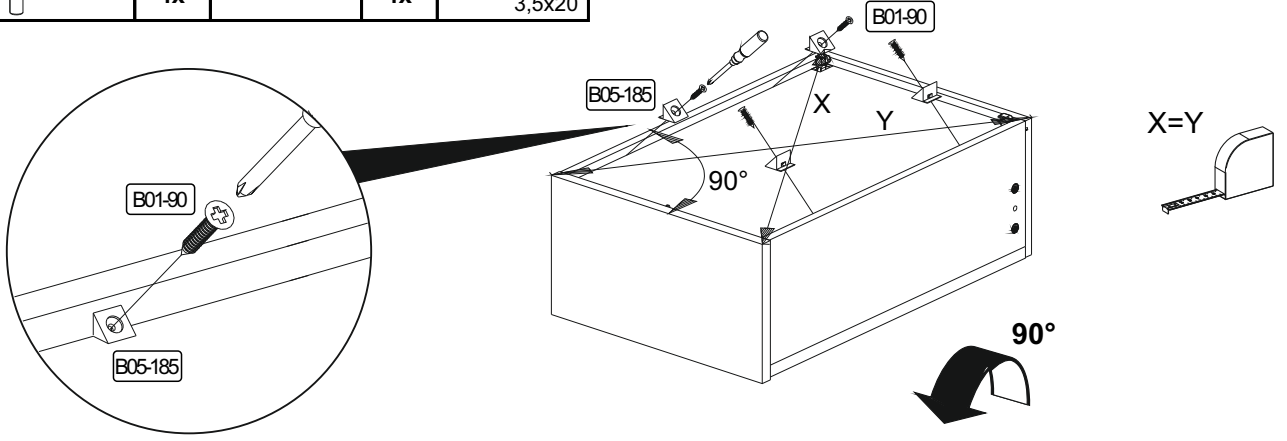

8

	B01-206	
	2x	6,3x22

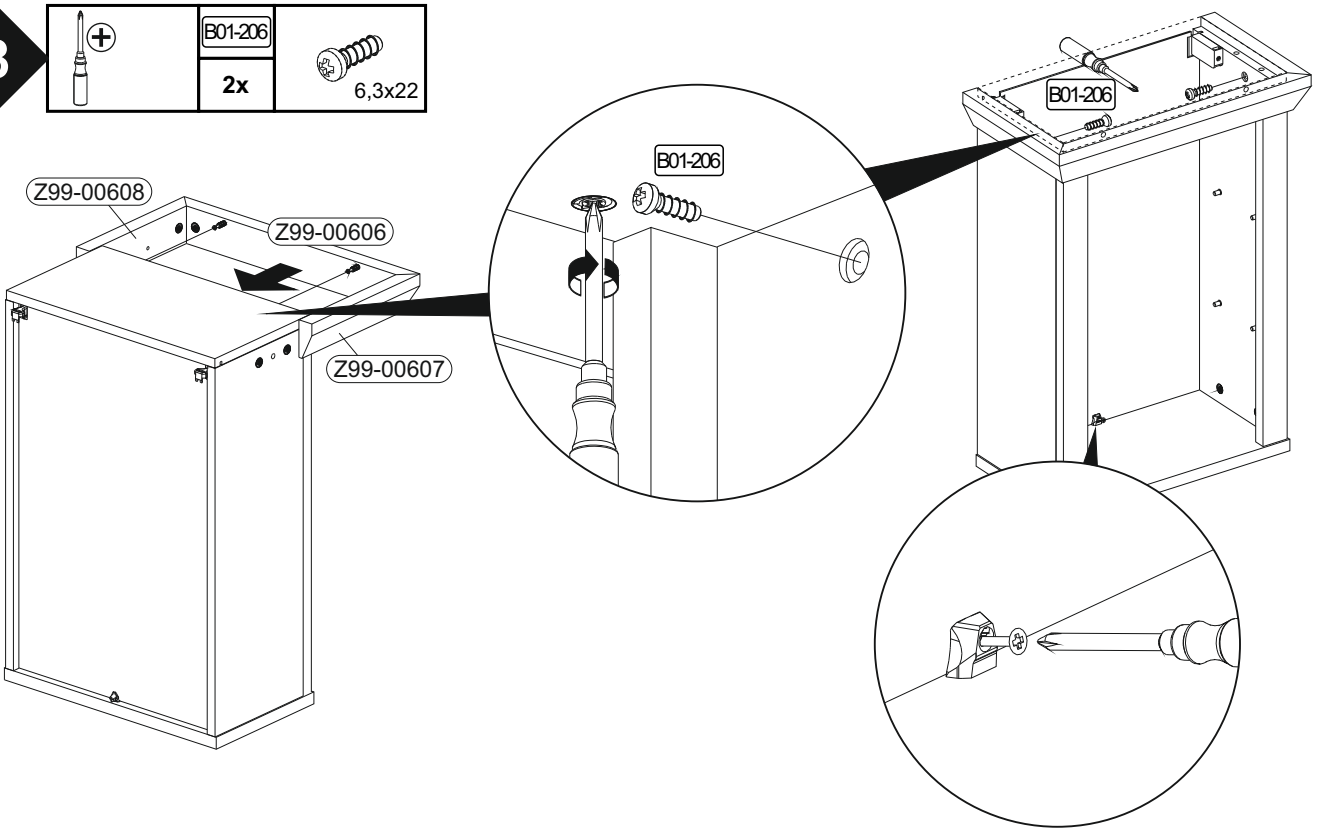

9

	B03-44		B01-80		B06-500		B01-327	
	2x		4x	3,5x13	1x		2x	M4x19

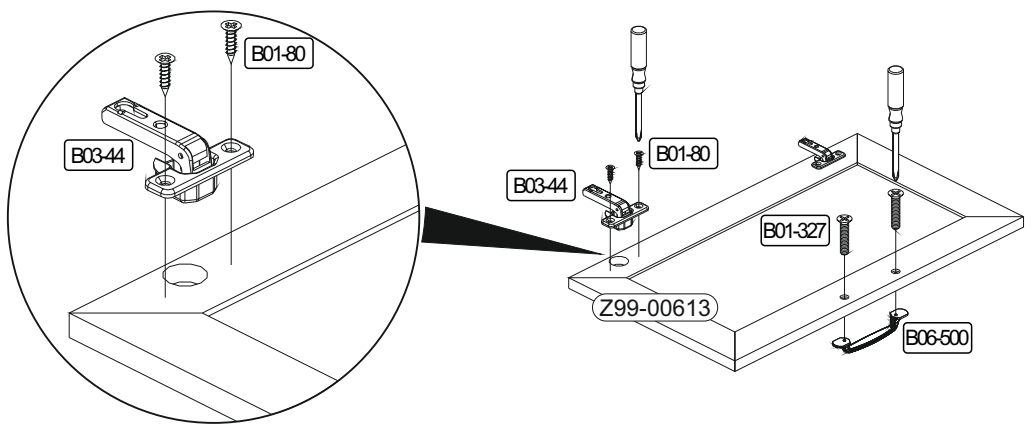

10

	B01-90		B03-44		B01-244	
	4x	3,5x20	2x		1x	



▶ SCAN ME

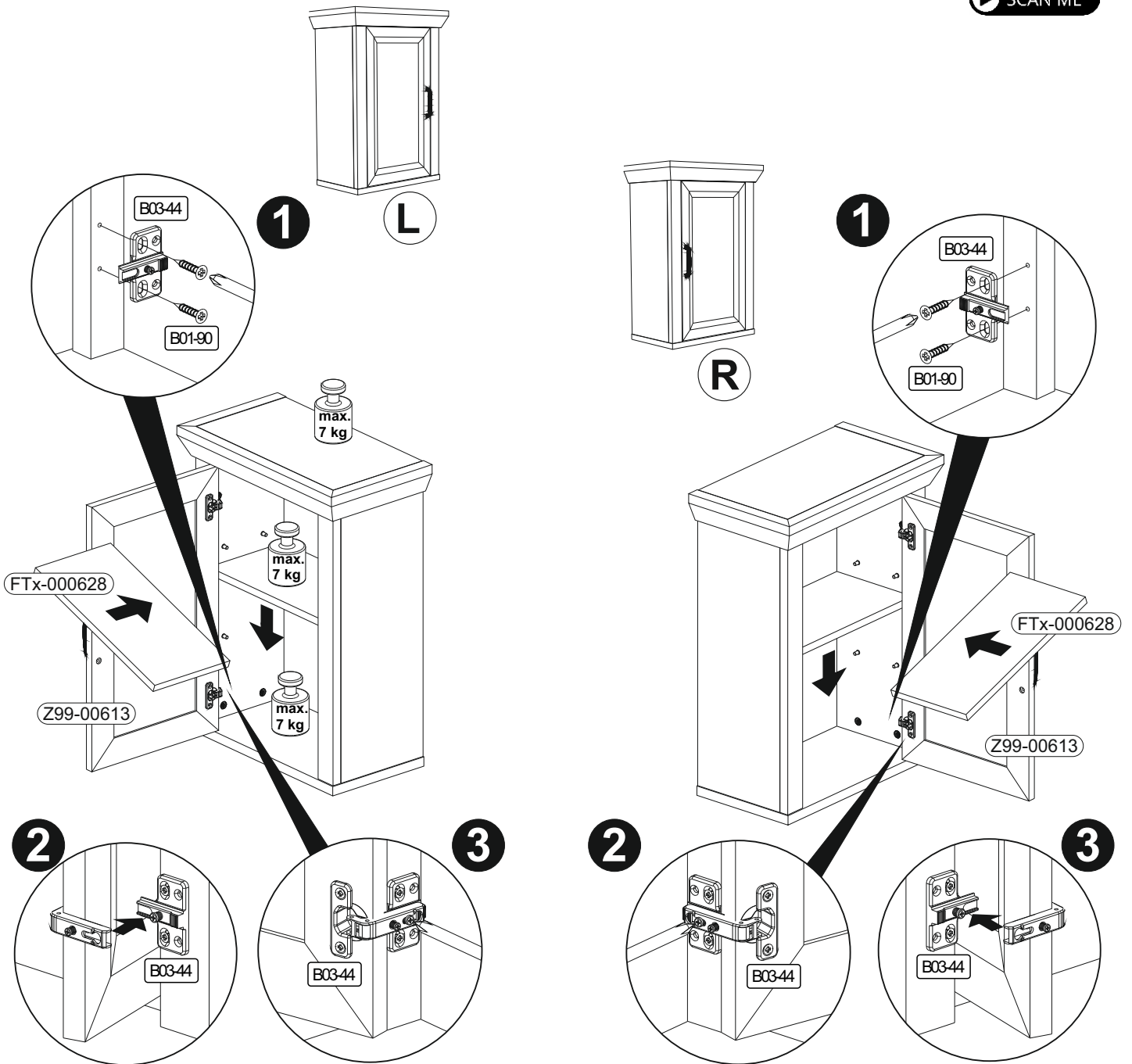

Türen einstellen (Scharniere justieren)
 Adjusting the doors (adjusting the hinges)
Régler les portes (ajuster les charnières)
 Sistemare le porte (regolare le cerniere)
Deuren instellen (scharnieren afstellen)
 Nastawić drzwi (wyregulować zawiasy)

Vyrovnejte dvířka (seřid'te závěsy)
 Nastavenie dverí (nastavenie závesov)
Állítsa be az ajtókat (állítsa be a zsanérokot)
 Reglare uși (ajustare balamale)
Kapilarnn ayarlanması (mentşelerin seviye ayarı)
 Регулировка дверей (регулировка шарнира)

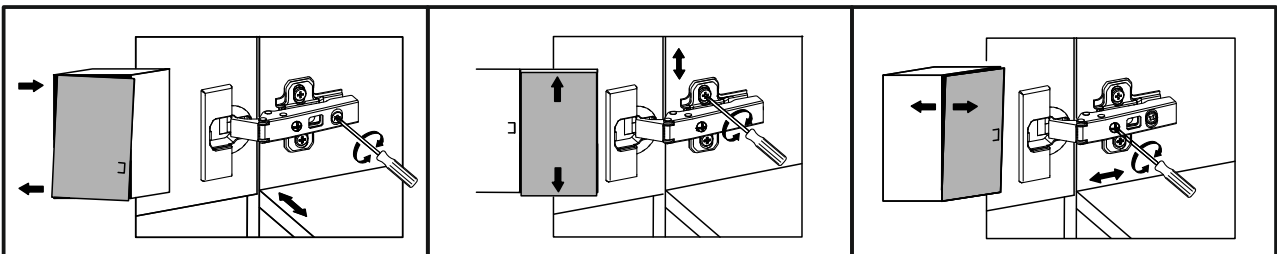

11

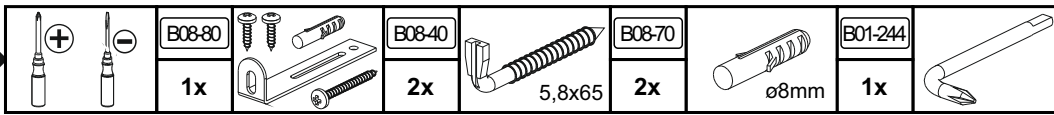

▶ SCAN ME

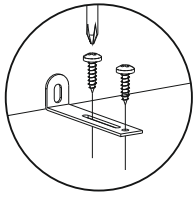

2

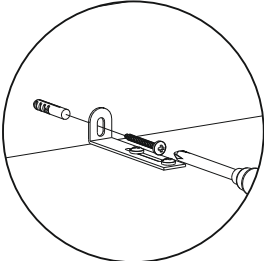

3

1

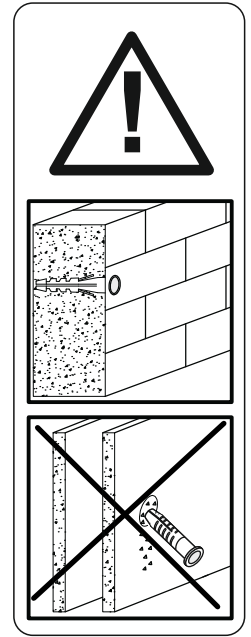
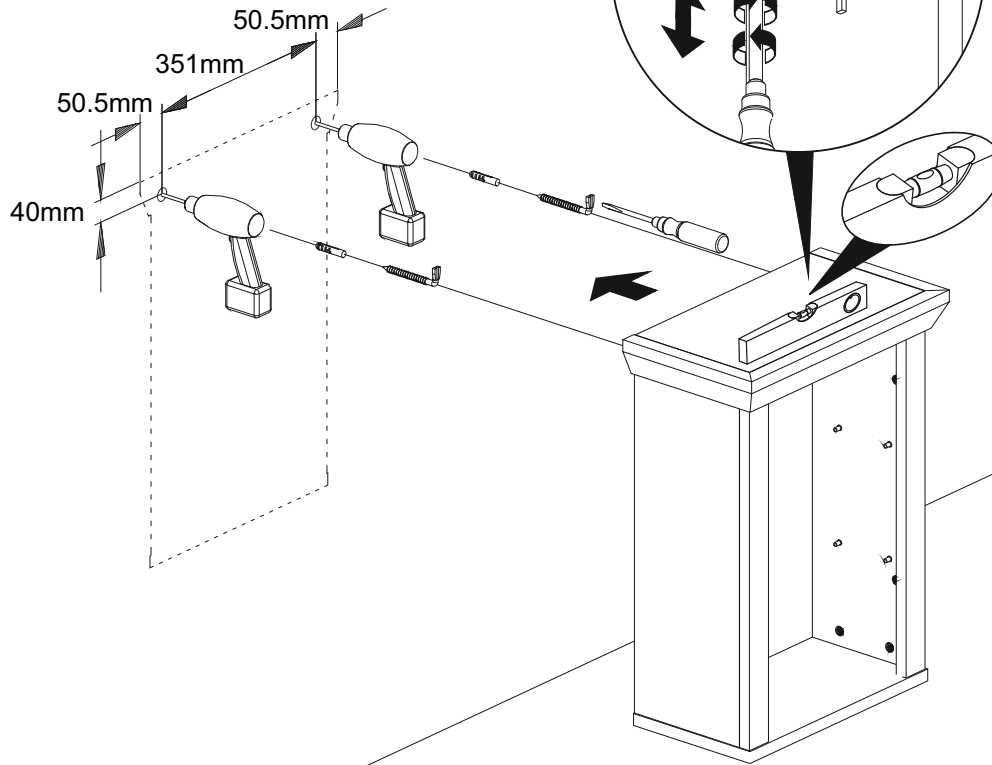
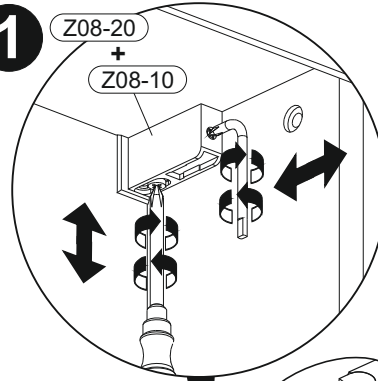

Achtung • Attention • Attenzione • Opgelet • Uwaga • Pozor • Figelem • Atenție • Dikkat • Внимание	
(D)	Wandbefestigung dient als Kippschutz - unbedingt anbringen! Bei einigen Wandtypen kann ein Spezialdübel erforderlich sein!
(GB)	The wall fastening serves to prevent tipping - be absolutely sure to mount it! For certain wall types, a special wall plug may be necessary!
(FR)	La fixation murale sert de protection contre le basculement – à installer impérativement ! Pour certains types de murs il faut des chevilles spéciales !
(TR)	Duvardaki sabitleme, devrilmeye karşı bir emniyet tedbiridir ve mutlaka monte edilmelidir! Bazı duvar tiplerinde bunun için özel bir dübel gerekli olabilir!
(IT)	Il fissaggio alla parete serve da protezione anti-ribaltamento – attaccarla assolutamente! Per alcune strutture di parete può essere necessario un tassello speciale!
(NL)	Bevestiging aan de muur dient als kantelbescherming – zeker en vast bevestigen! Bij enkele muurtypes is een speciale plug misschien vereist!
(RU)	Обязательно установите крепление на стене во избежание опрокидывания! Для некоторых типов стен может потребоваться специальный дюбель!
(CZ)	Montáž na stěnu slouží jako ochrana proti převrnutí – bezpodmínečně umístěte! U některých typů stěn může být zapotřebí speciální hmoždinka!
(HU)	A terméket a falhoz kel rögzíteni, különben az felborulhat! Egyes fal típusoknál speciális tiplit kell használni!
(RO)	Sistemul de fixare la perete servește ca protecție la răsturnare - de montat obligatoriu! Pentru unele tipuri de pereți este posibil să fie necesar un diblu special!
(PL)	Mocowanie do ściany jest jednocześnie zabezpieczeniem przed przewróceniem – koniecznie zamontować! Do niektórych rodzajów ścian koniecznie zastosować specjalne kołki mocujące.
(SK)	Upevnenie na stenu slúži ako ochrana proti prevráteniu – bezpodmienečne použite! Pre niektoré druhy stien môže byť potrebná špeciálna hmoždinka!