

WF531927NAA

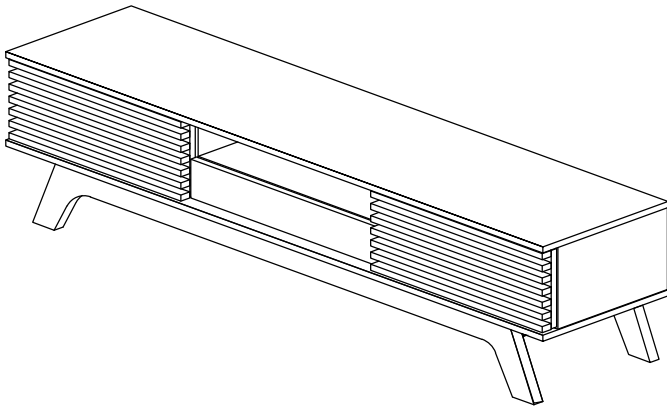

Please check that you have all the parts listed before you start assembling, if you do find that something is missing, do not continue assembly, please contact us immediately.

Note: Please do not fully tighten all the screws until the overall frame is built

Bitte überprüfen Sie, ob alle Teile mitgeliefert sind, bevor Sie mit der Montage beginnen. Wenn Sie festlegen, dass etwas fehlt, setzen Sie die Montage nicht fort. Bitte kontaktieren Sie uns sofort.

Achtung : Bitte ziehen Sie nicht alle Schrauben fest, bevor die Montage abgeschlossen ist !

D Gebrauchsanweisung

NL Gebruiksrichtlijnen

IT Istruzioni per l'uso

CZ Pokyny k použití

HU Használati útmutató

PT Instruções de utilização

SK Pokyny k použitiu

GB Instructions for use

FR Instructions d'utilisation

PL Instrukcja obsługi

ES Instrucciones de empleo

RO Instrucțiuni de folosire

RU Инструкция по монтажу

TR Kullanım talimatları

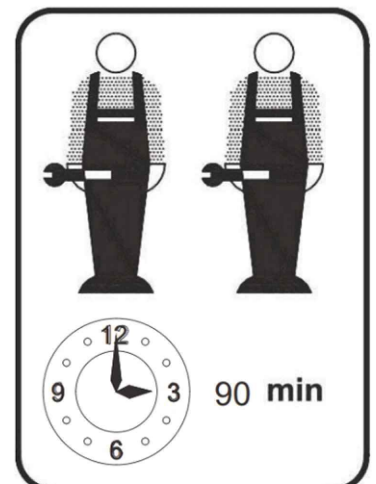

Importeur	Decobus Handel GmbH
Adresse	Innungsstraße 9, 21244 Buchholz, Deutschland
URL	https://www.decobusgroup.de
Hersteller	Timber Art Design Sdn. Bhd.
Adresse	JBB 20/14 PTD 10638 Kawasan Industri 2, Jalan Kempas 1, Batu 7 Jalan Bakri, 84200 Muar Johor, West Malaysia
Email/URL	www.timberartdesign.com
EC REP	Decobus Handel GmbH Innungsstraße 9, 21244 Buchholz, Deutschland https://www.decobusgroup.de

**FR - Notice de montage / EN - Assembly instructions / PT - Instruções de montagem /
ES - Prospecto de montaje / DE - Montageanleitung / IT - Istruzioni di montaggio /
NL - Montagehandleiding**

FR - IMPORTANT! CONSERVER POUR CONSULTATION ULTERIEURE: LIRE ATTENTIVEMENT

- A monter par un adulte. Un adulte doit vérifier le bon assemblage avant l'emploi
- ATTENTION! tenir les vis et petits éléments et sachets hors de portée des enfants
- Bien identifier les éléments avant de commencer le montage
- Ne pas utiliser votre article lorsque l'un de ses éléments est cassé ou manquant
- En cas de problème contactez notre service après-vente
- Toujours suivre les instructions du fabricant
- Entretien: nettoyer avec un chiffon doux et sec. En cas de taches plus grosses, frottez soigneusement avec une éponge légèrement humide et non abrasive
- Ne pas sauter sur le lit

EN - IMPORTANT! KEEP FOR FUTURE REFERENCE: READ CAREFULLY

- To be assembled by an adult. Assembly must be checked by an adult before use
- WARNING! keep all screws, small parts and plastic bags out of the reach of children
- Properly identify all parts before assembling
- Never use your item if any of its parts are broken or missing
- Should any problems arise, please contact our After Sales Service
- Manufacturer's instructions shall be followed at all times
- Care: clean with a soft, dry cloth. In case of larger stains, carefully rub with a slightly damp, non-abrasive sponge
- Do not jump on the bed

PT - IMPORTANTE! GARDE PARA CONSULTA POSTERIOR: LER ESTAS INSTRUÇÕES CUIDADOSAMENTE

- A ser montado por um adulto. Um adulto deve verificar a boa montagem antes da utilização
- Atenção! mantenha os parafusos, acessórios pequenos e saco de plástico fora do alcance das crianças
- Identifique bem os acessórios antes de começar a montagem
- Não utilizar o artigo se um dos elementos está em falta ou danificado
- Para qualquer esclarecimento, contacte os nossos serviços através do telefone
- As instruções do fabricante devem ser sempre cumpridas
- Manutenção: limpe com um pano macio e seco. Em caso de manchas maiores, esfregue cuidadosamente com uma esponja ligeiramente húmida e não abrasiva
- Não salte na cama

ES - IMPORTANTE! CONSERVAR PARA FUTURAS CONSULTAS: LEER DETENIDAMENTE

- A montar por un adulto. Un adulto debe comprobar el buen montaje antes de la utilización
- ¡ADVERTENCIA! mantener los tornillos, los pequeños elementos y bolsitas fuera del alcance de los niños
- Identificar debidamente los elementos antes de empezar el montaje
- No utilizar este artículo si uno de los elementos falta o esta roto
- Si tiene problemas, contactar nuestro servicio postventa
- Deben seguirse siempre las instrucciones del fabricante Cuidados: limpiar con un paño suave y seco. En caso de manchas grandes, frotar con cuidado utilizando una esponja húmeda no abrasiva
- No saltar sobre la cama

DE - WICHTIG! FÜR SPÄTERE BEZUGNAHME AUFBEWAHREN: SORGFÄLTIG LESEN

- Von einem Erwachsenen zu montieren. Die korrekte Montage muss vor Gebrauch von einem Erwachsenen geprüft werden
- Achtung! die Schrauben und kleinen Teile ausserhalb der Reichweite von Kindern lagern
- Vor Montagebeginn alle Teile identifizieren
- Ihren Artikel nicht benutzen, wenn eines seiner Bestandteile beschädigt ist oder fehlt
- Im Problemfall Ihren Kundendienst anrufen
- Stets die Herstelleranweisungen beachten
- Wartung: Mit einem weichen, trockenen Tuch reinigen. Bei größeren Flecken vorsichtig mit einem leicht feuchten, nicht scheuernden Schwamm abreiben
- Nicht auf dem Bett springen

IT - IMPORTANTE! CONSERVARE QUESTE INFORMAZIONI PER ULTERIORI CONSULTAZIONI: LEGGI ATTENTAMENTE

- Il montaggio deve essere eseguito da un adulto. Un adulto dovrà verificare il corretto montaggio prima dell'uso
- ATTENZIONE! tenere le viti ed i componenti di piccole dimensioni lontano dalla portata dei bambini
- Controllare i pezzi prima del montaggio
- L'articolo non deve essere utilizzato in caso di elementi mancanti o danneggiati
- In caso di necessità contattare il nostro servizio post-vendita
- Seguire sempre le istruzioni del costruttore
- Manutenzione: pulire con un panno morbido e asciutto. Per le macchine più grandi, strofinare accuratamente con una spugna leggermente umida e non abrasiva
- Non saltare sul letto

NL - BELANGRIJK! BEWAAR VOOR LATERE RAADPLEGING: LEES AANDACHTIG

- Moet door een volwassene worden gemonteerd. Voor gebruik moet een volwassene controleren dat het product goed in elkaar is gezet
- WAARSCHUWING! schroeven en kleine elementen en zakjes buiten bereik van kinderen houden
- De elementen goed identificeren alvorens met de montage te beginnen
- Uw artikel niet gebruiken wanneer een van de onderdelen kapot is of ontbreekt
- Neem bij problemen contact op met onze klantenservice
- Volg altijd de instructies van de fabrikant
- Onderhoud: maak schoon met een zachte en droge doek. In geval van grotere vlekken, veeg voorzichtig schoon met een licht bevochtigde en niet-schurende spons
- Niet springen op het bed

Stückliste

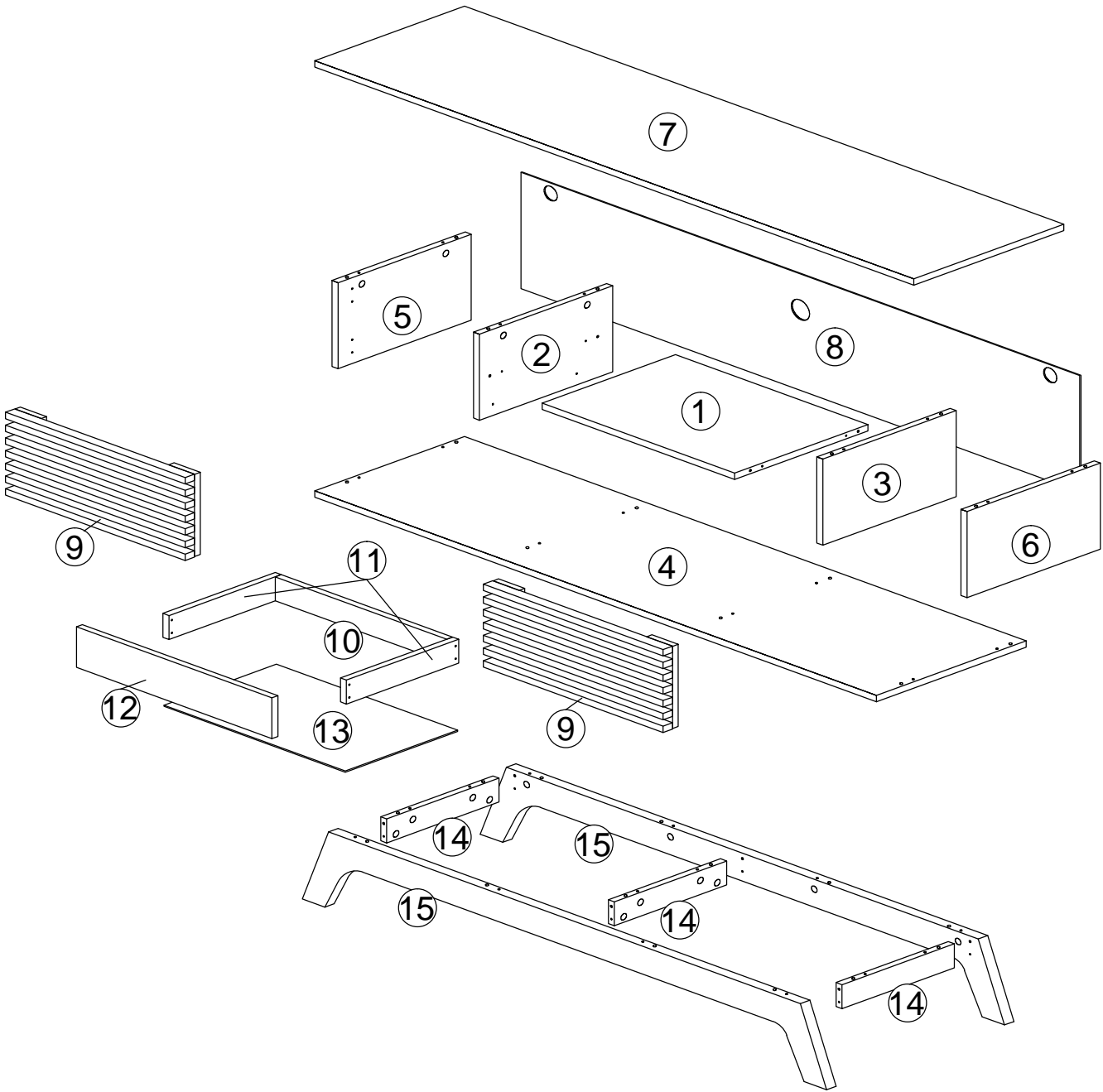

Part List-Stückliste WF531927NAA

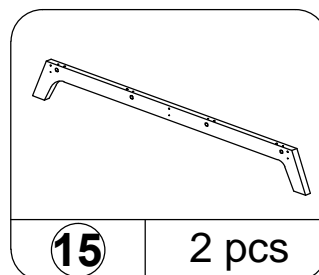
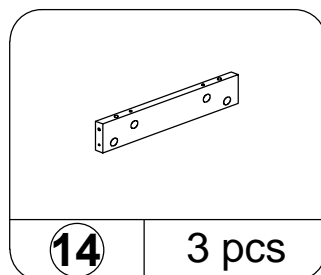
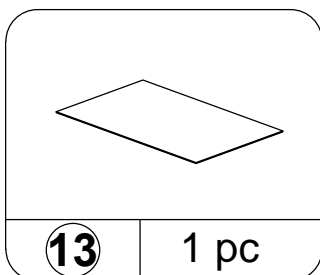
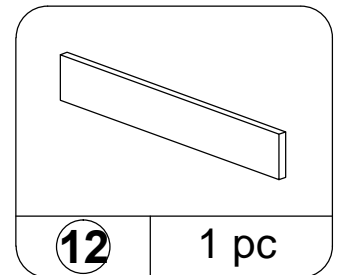
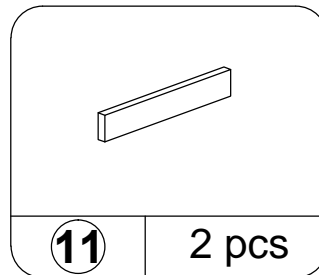
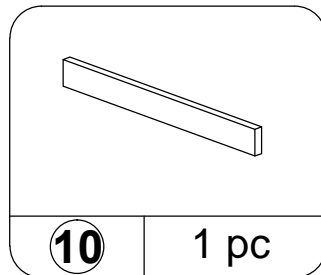
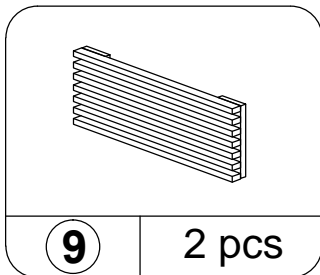
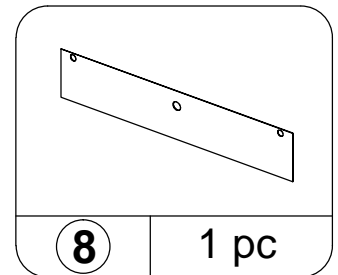
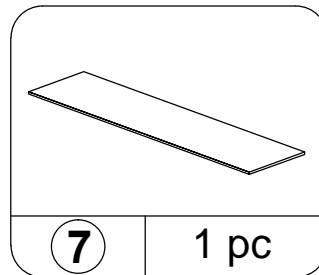
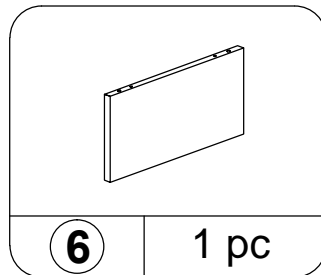
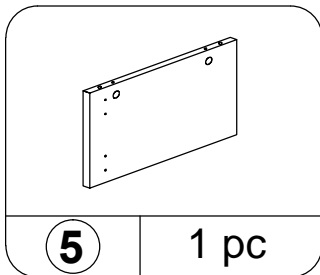
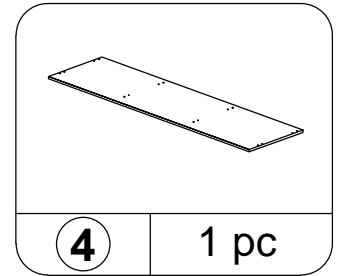
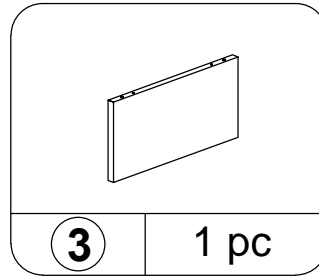
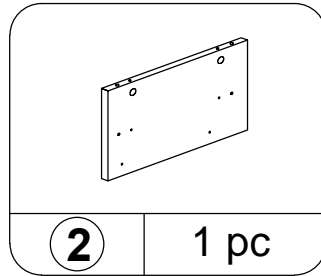
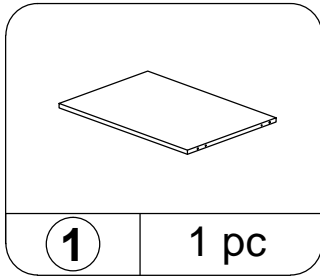

Hardware List- Hardware-Liste

WF531927NAA

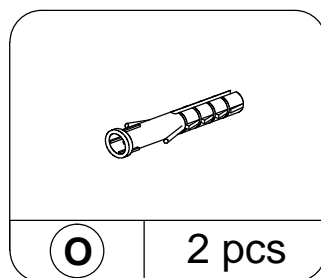
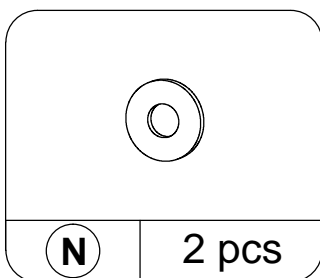
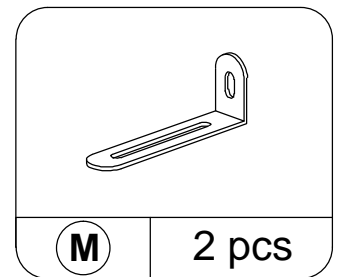
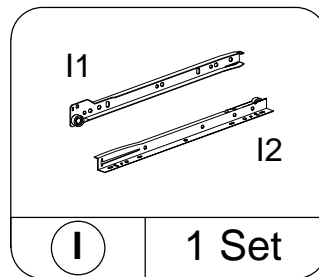
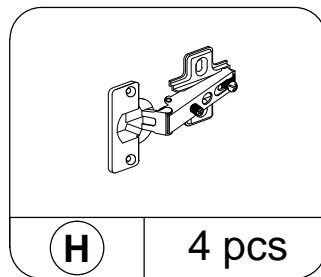
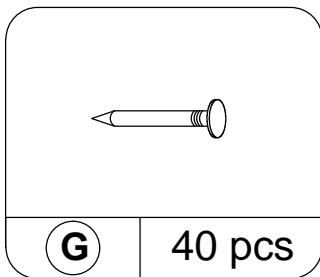
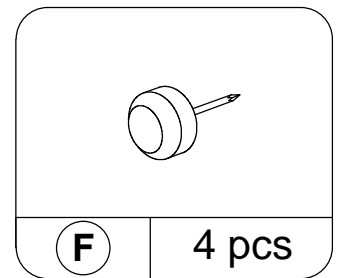
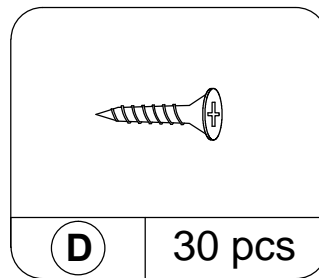
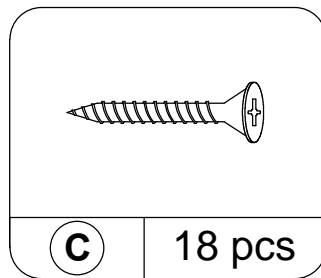
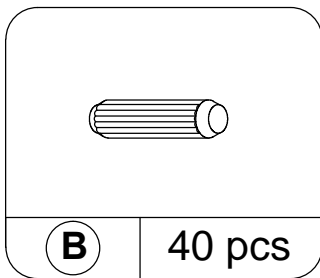
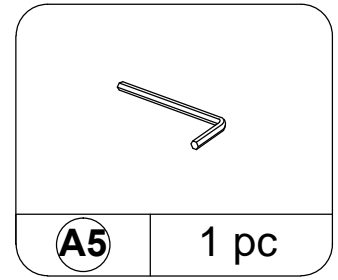
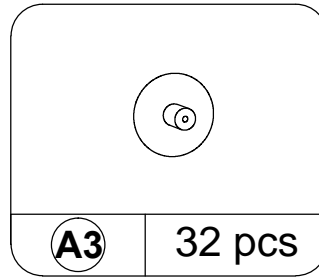
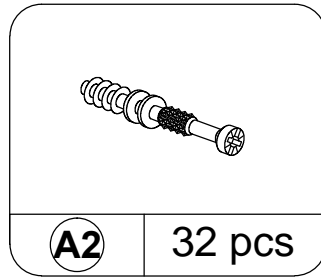
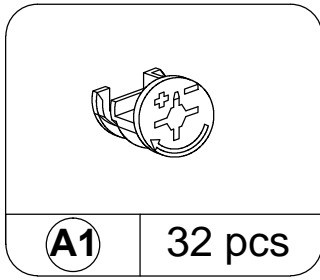

Tools Required (Not Included)

Werkzeuge benötigt (Nicht enthalten)

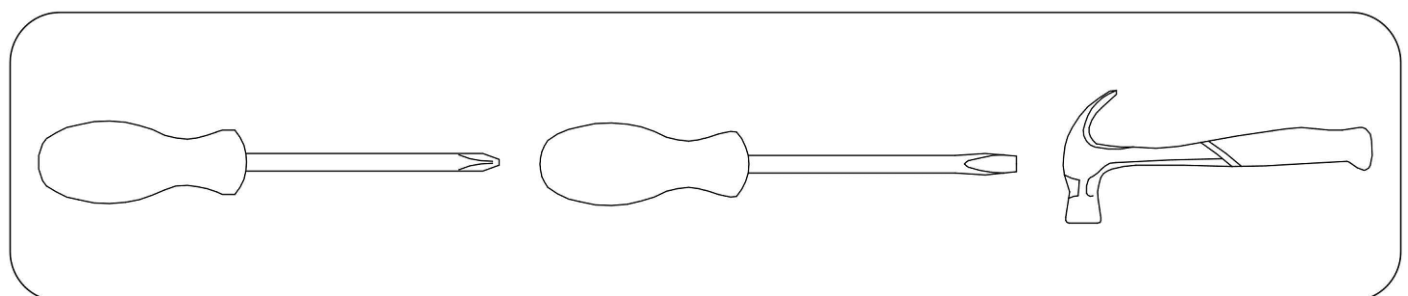

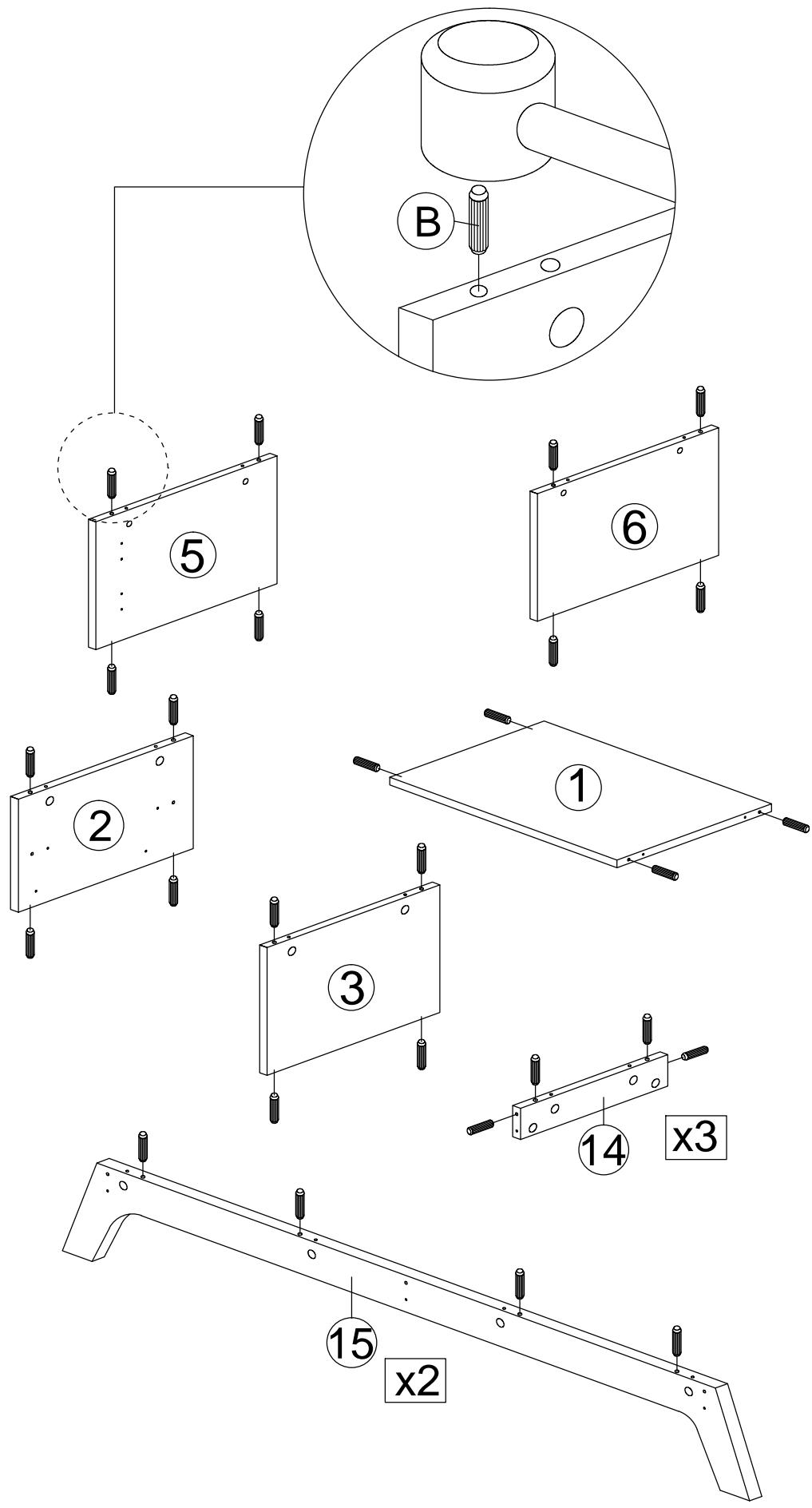

2

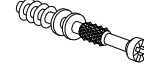
	A2 32 pcs
--	-----------

	D 2 pcs
--	---------

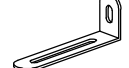
	M 2 pcs
--	---------

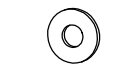
	N 2 pcs
--	---------

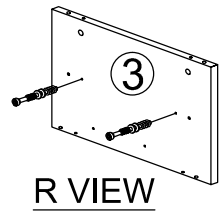
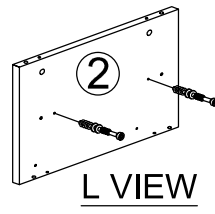
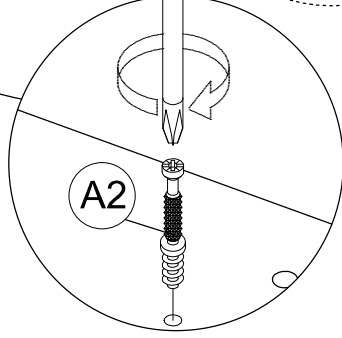
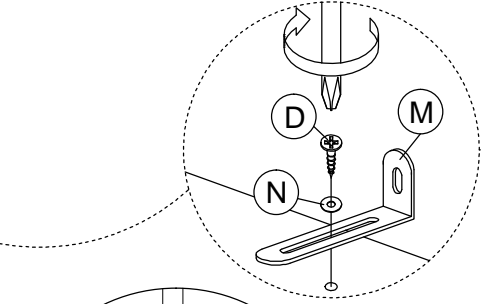
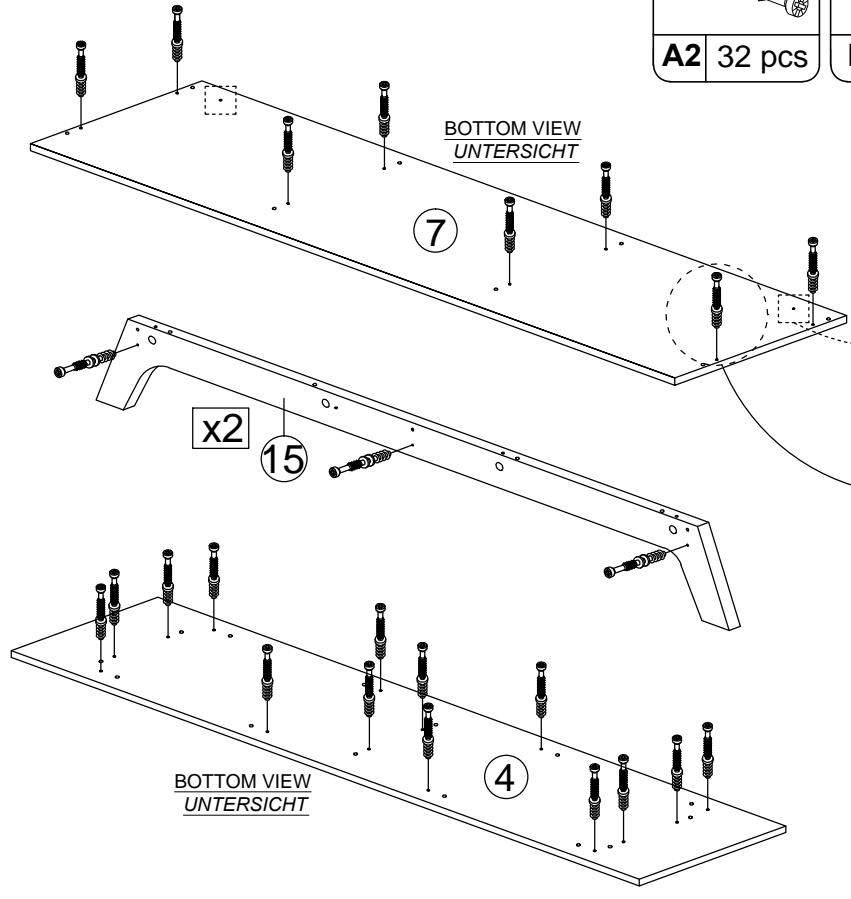

3

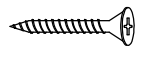
	C 8 pcs
---	---------

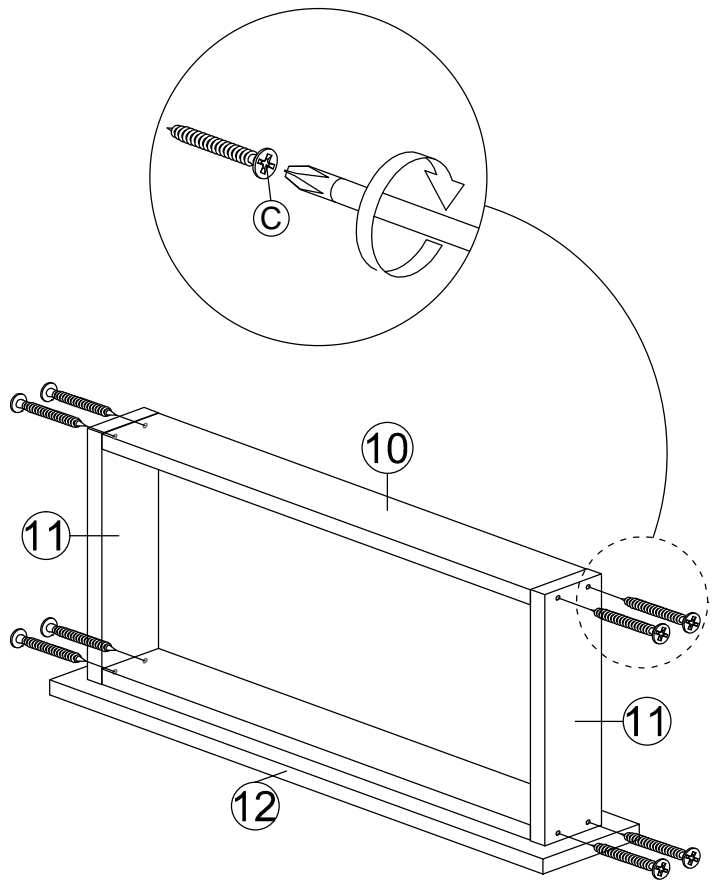

4

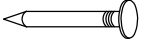

G 10 pcs

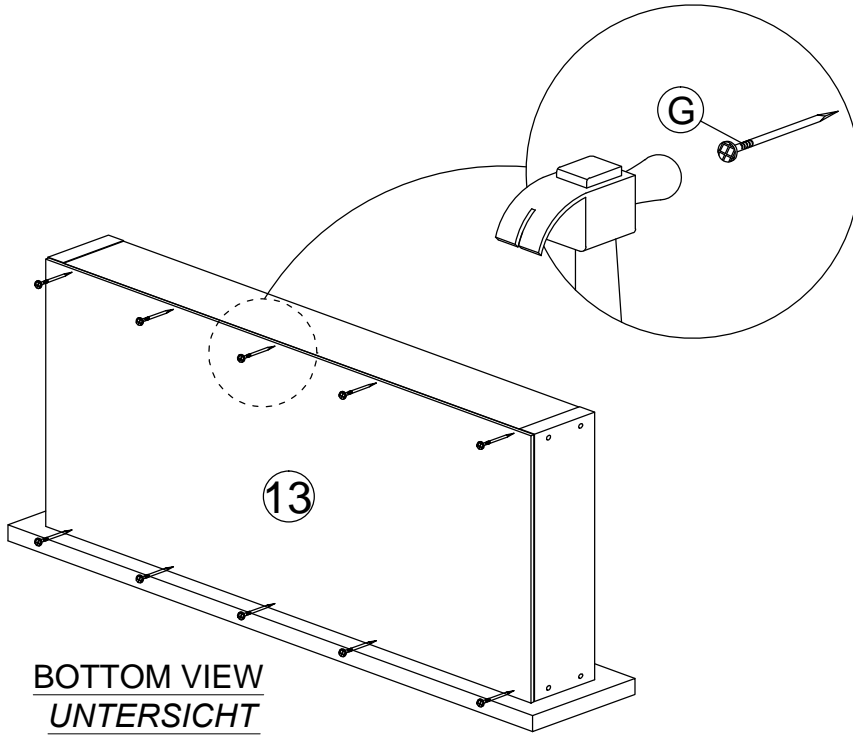

BOTTOM VIEW
UNTERSICHT

5

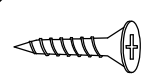

D 6 pcs



I 1 set

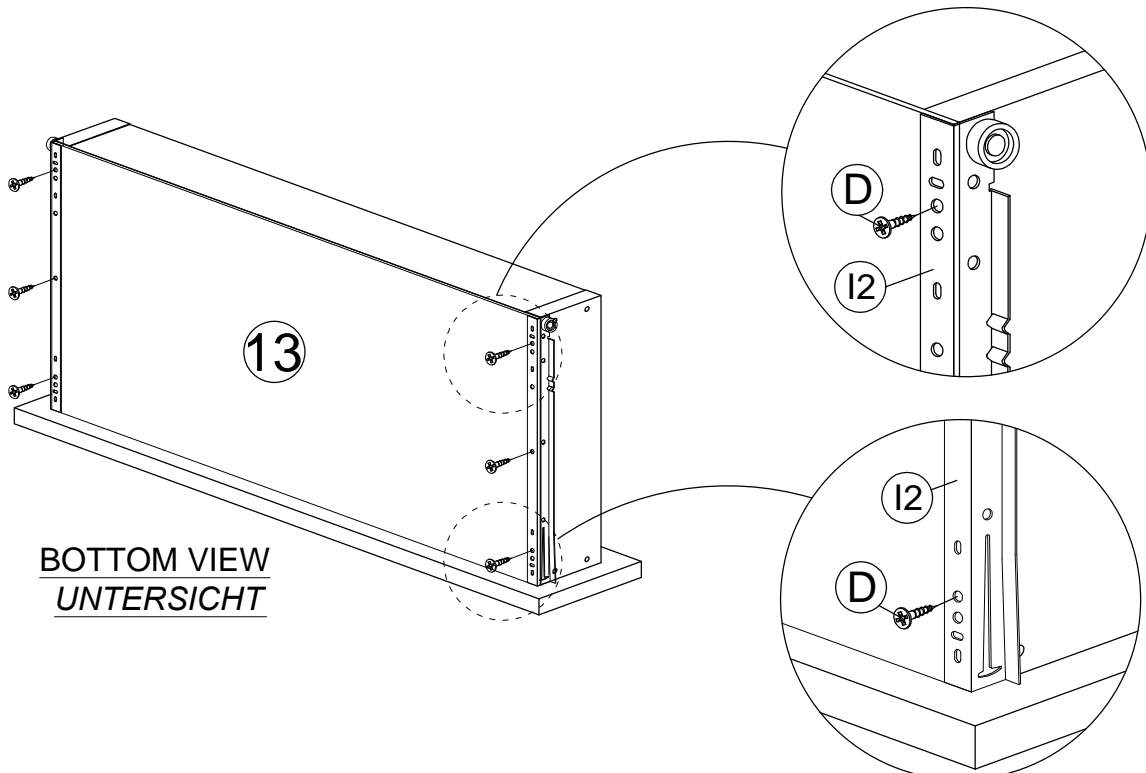

BOTTOM VIEW
UNTERSICHT

6

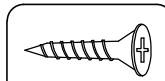

D 6 pcs

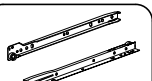

I 1 set

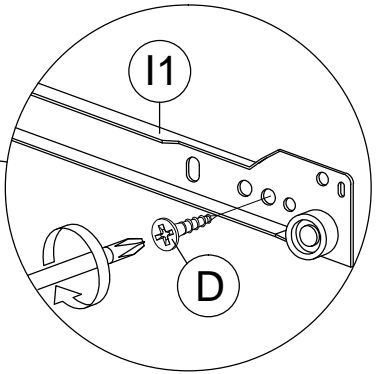
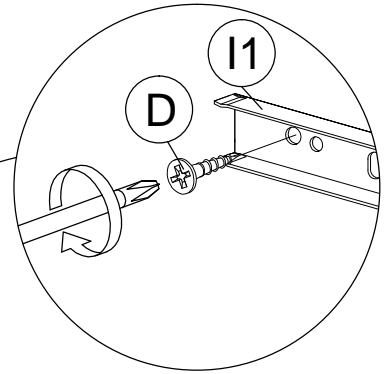
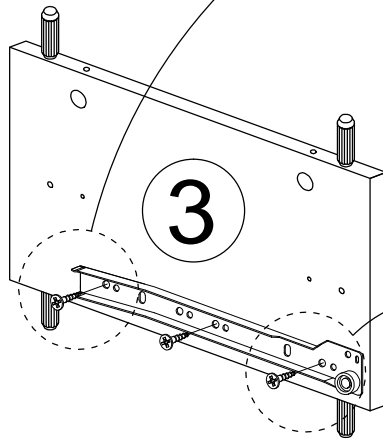
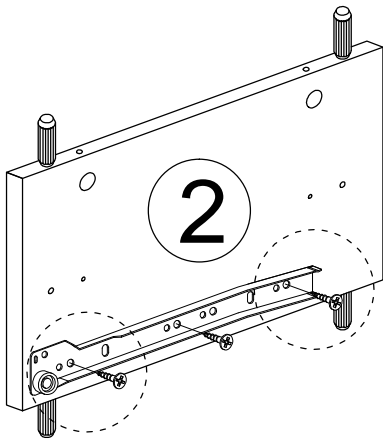

7



A1 4 pcs



A3 4 pcs

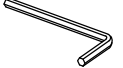

A5 1 pc

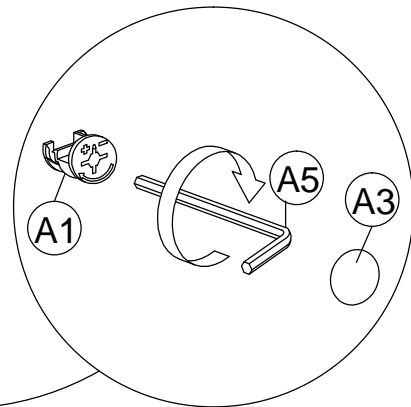
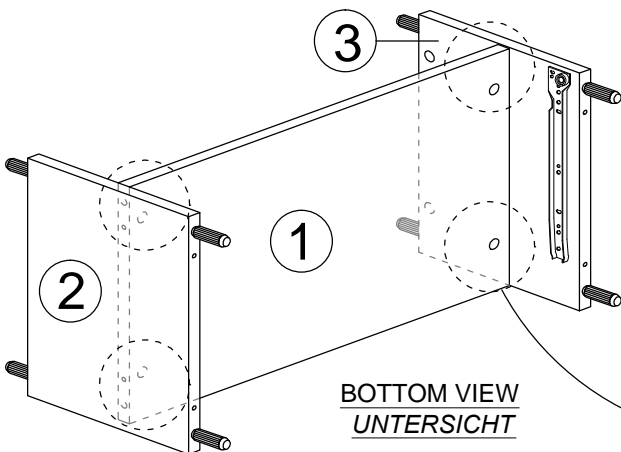

8

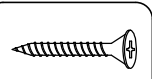

C 8 pcs

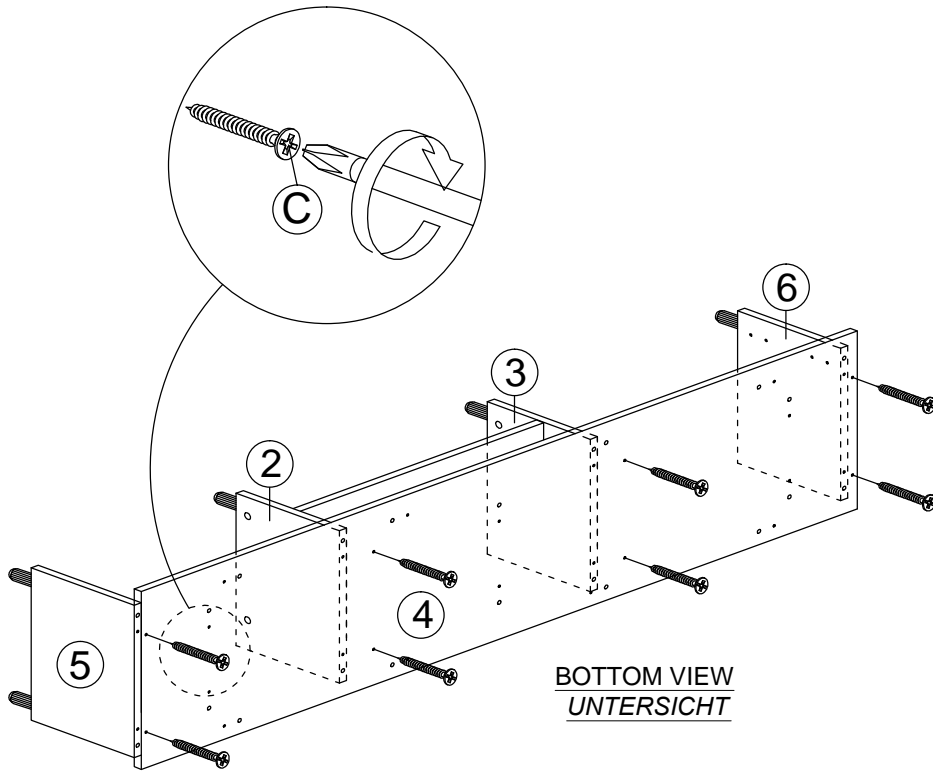

9



A1 8 pcs



A3 8 pcs

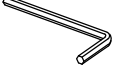

A5 1 pc

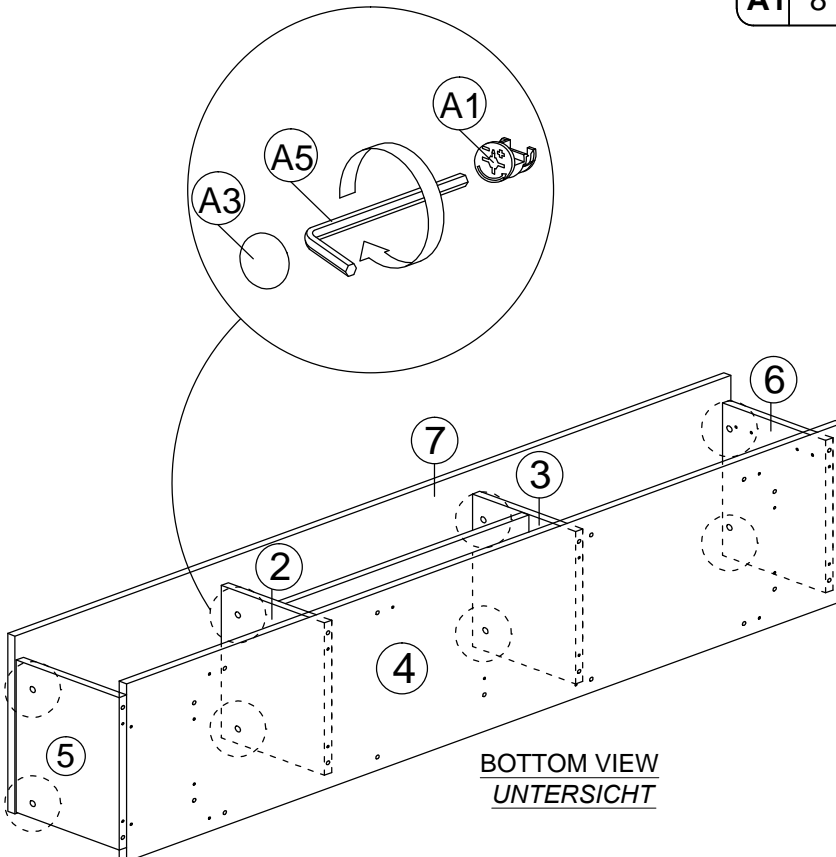

10

	A1 6 pcs
--	-----------------

	A3 6 pcs
--	-----------------

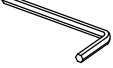
	A5 1 pc
--	----------------

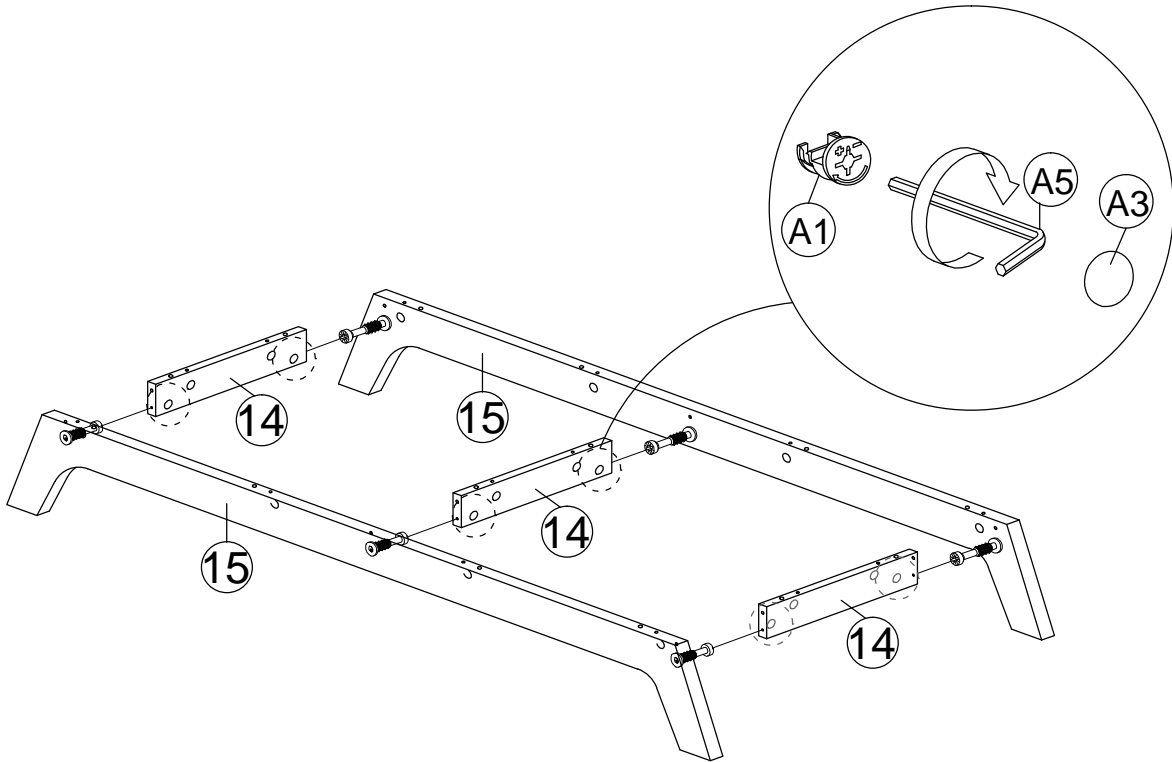

11

	A1 14 pcs
---	------------------

	A3 14 pcs
---	------------------

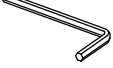
	A5 1 pc
---	----------------

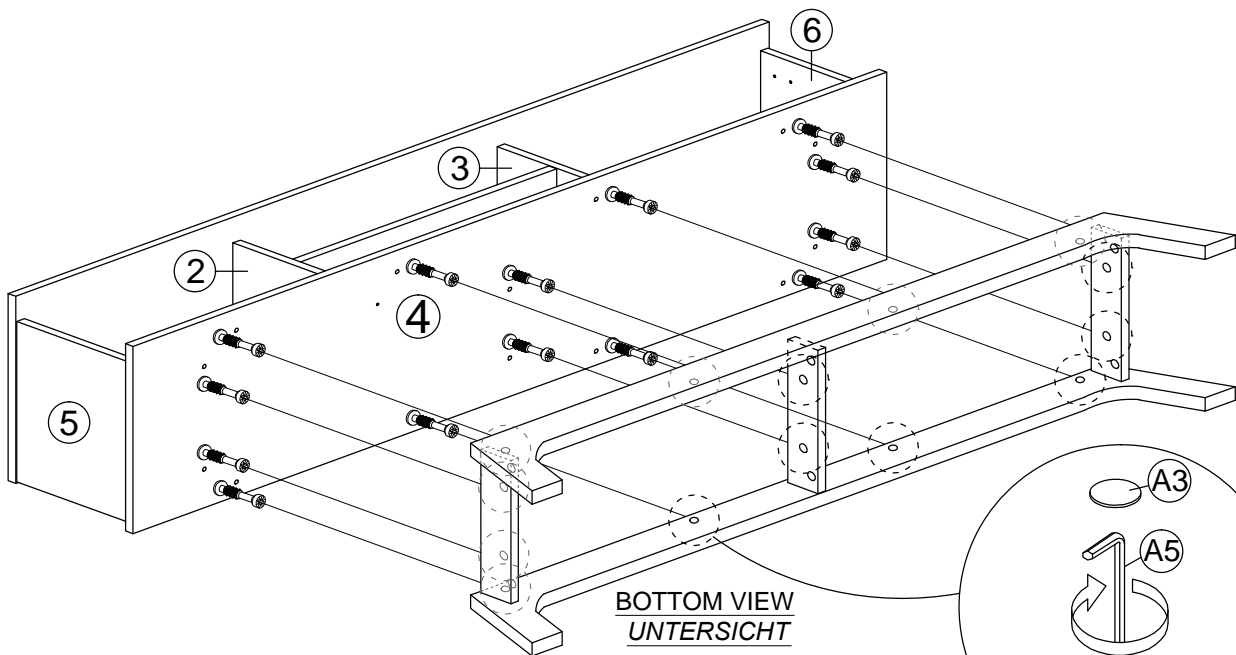

12

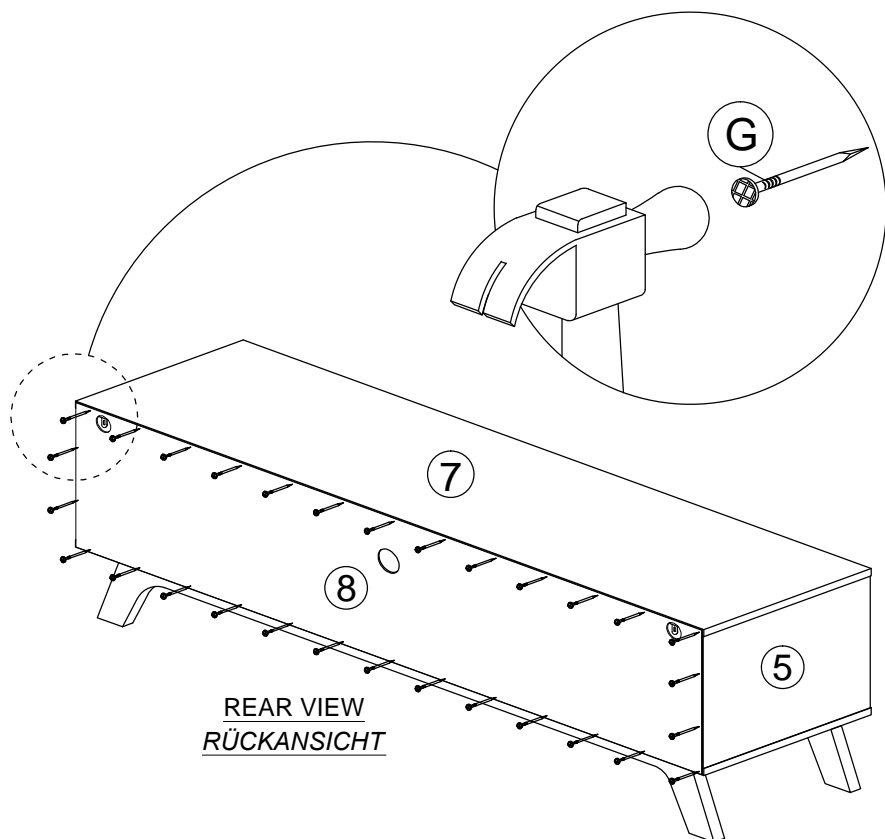
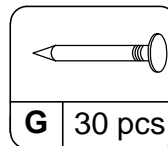

13

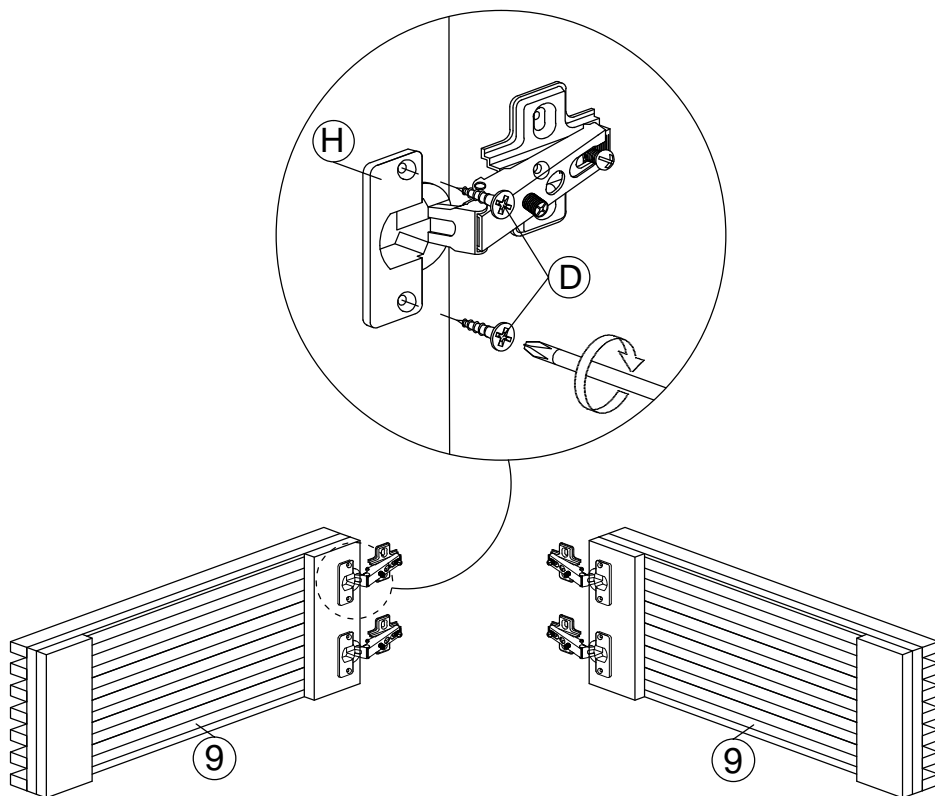
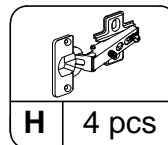
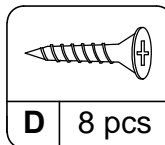

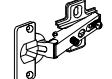
	
D 8 pcs	H 4 pcs

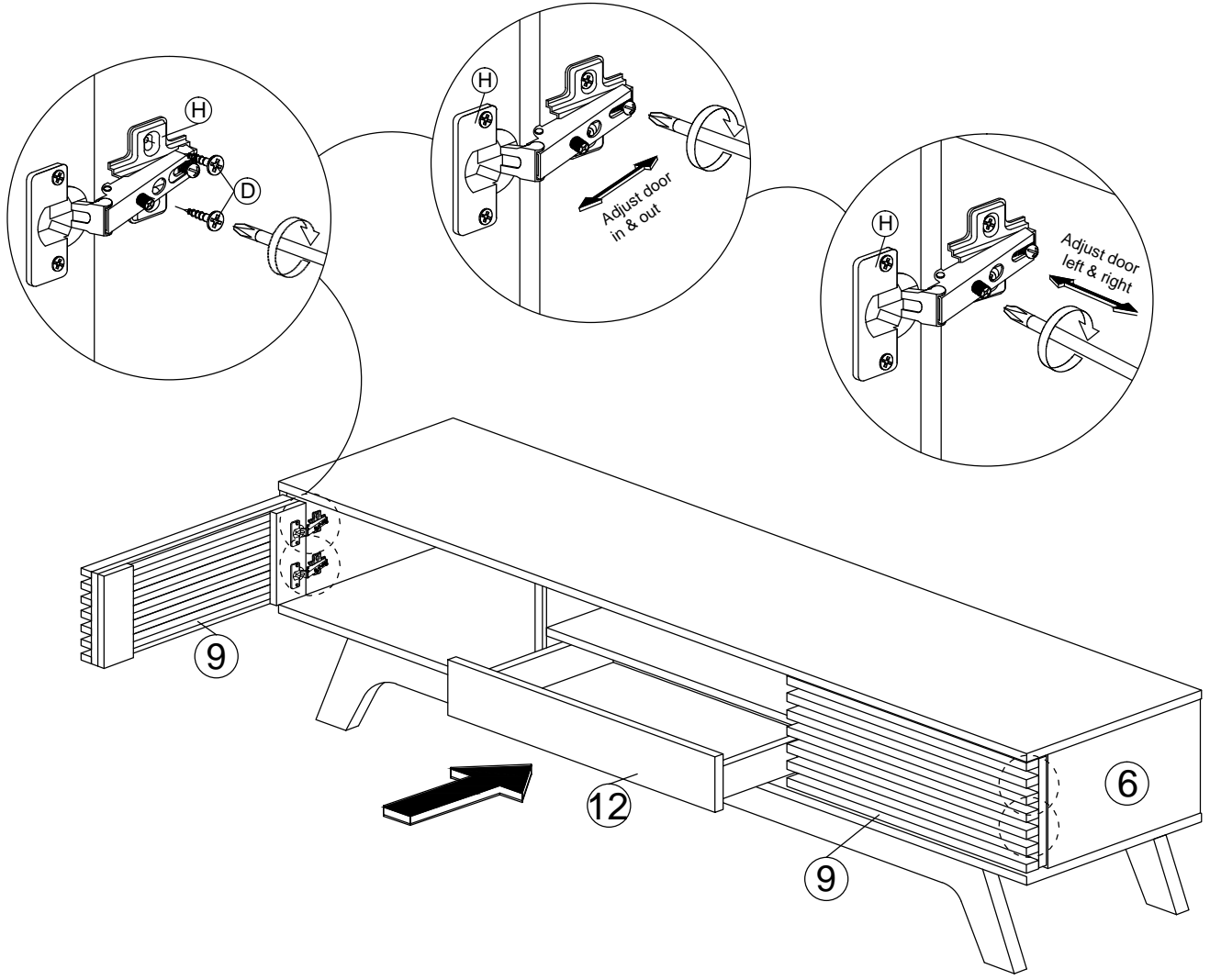



FURNITURE ANTI-TIPPING INSTALLATION

MÖBEL KIPPSCHUTZINSTALLATION



This anti-tipping must be attached to a wall stud using screw enclosed:

1. After assembling the unit place it against the wall where it will be permanently positioned.
2. Working from inside the cabinet, loosen bracket's screw and adjust the bracket to rear wall of the cabinet as shown in diagram.
3. Use a pencil to mark through the screw hole in the bracket, where the bracket has to be secured to the wall.
4. Move the cabinet away from the wall and drill a hole to the wall at the marked position & fitted the supplied wall anchor into the drilled hole.
5. With the wall anchor in position, move the cabinet back to the wall and adjust bracket out till the horizontal arm of the bracket touches the wall.
6. Using the screw supplied, secure the horizontal arm of the brackets to the backside of the cabinet onto the wall.
7. Then, tighten back the bracket screw located on the bottom side of the cabinet top panel as shown in diagram.

Dieser Kippschutz muss mit der beiliegenden Schraube an einem Wandpfosten befestigt werden:

1. Nach dem Zusammenbau des Geräts platzieren Sie es an der Wand, wo es dauerhaft positioniert wird.
2. Lösen Sie von der Innenseite des Schrankes aus die Schraube der Halterung und passen Sie die Halterung an die Rückwand des Schrankes an, wie in der Abbildung gezeigt.
3. Markieren Sie mit einem Bleistift durch das Schraubenloch in der Halterung, wo die Halterung an der Wand befestigt werden muss.
4. Bewegen Sie den Schrank von der Wand weg und bohren Sie an der markierten Stelle ein Loch in die Wand und setzen Sie den mitgelieferten Wandanker in das gebohrte Loch ein.
5. Wenn der Wandanker in Position ist, bewegen Sie den Schrank zurück an die Wand und passen Sie die Halterung an, bis der horizontale Arm der Halterung die Wand berührt.
6. Befestigen Sie den horizontalen Arm der Halterung mit der mitgelieferten Schraube an der Rückseite des Schrankes an der Wand.
7. Ziehen Sie dann die Halterungsschraube an der Unterseite der oberen Schrankplatte wieder fest, wie in der Abbildung gezeigt.

