

B341642412COM00UD



Look inside for Assembly Manual

Check us out!



littleseedskids.com

1642412COM LS Monarch Hill 3 Drawer Dresser



Keep this Assembly Manual for future reference

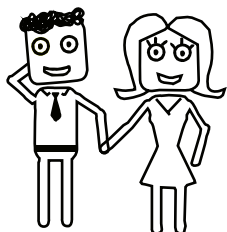
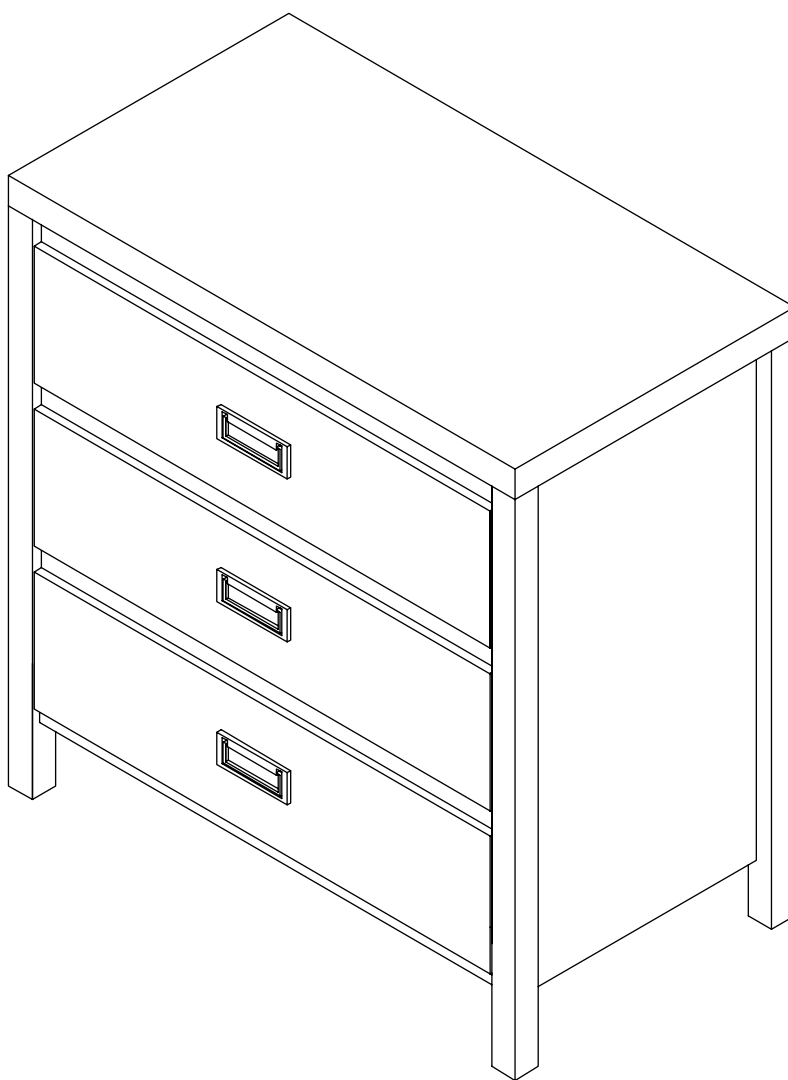

Two Adults
recommended
for assembly

This product is not intended for commercial use

Do NOT return this product!

For missing or broken parts
- Visit littleseedskids.com
- Call 1-800-489-3351

Follow little seeds on





Do NOT return this product!
Contact our friendly customer service team first for help

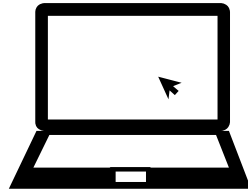
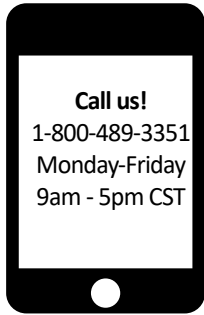

Visit littleseedskids.com to view the limited warranty valid in the U.S and Canada

Assembly Tips



Helpful Hints

PEOPLE NEEDED FOR ASSEMBLY: **1-2**
ESTIMATED ASSEMBLY TIME: **1 HOUR**

- Open your item in the area you plan to keep it for less heavy lifting
- Identify, sort and count the parts before attempting assembly
- Compression dowels are tapped in with a hammer
- Slides are labeled with a R (right) and L (left) for proper placement
- Make sure to always face the point on the top of the Cam Lock towards the outer edge
- Use all the nails provided for the back panel and spread them out equally
- Back Panel must be used to make sure your unit is sturdy
- Do NOT use harsh chemicals or abrasive cleaners on this item
- Never push, pull, or drag your furniture



Before You Start

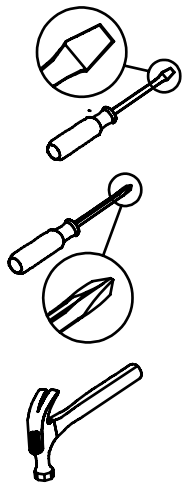

- ✓ Read through each step carefully and follow the proper order
- ✓ Separate and count all your parts and hardware
- ✓ Give yourself enough room for the assembly process
- ✓ Have the following tools: Flat Head Screwdriver, #2 Phillips Head Screwdriver and Hammer
- ✓ Caution: If using a power drill or power screwdriver for screwing, please beware to slow down and stop when screw is tight. Failure to do so may result in stripping the screw,

Cam Lock Fastening System

This Cam Lock Fastening System will be used throughout the assembly process.

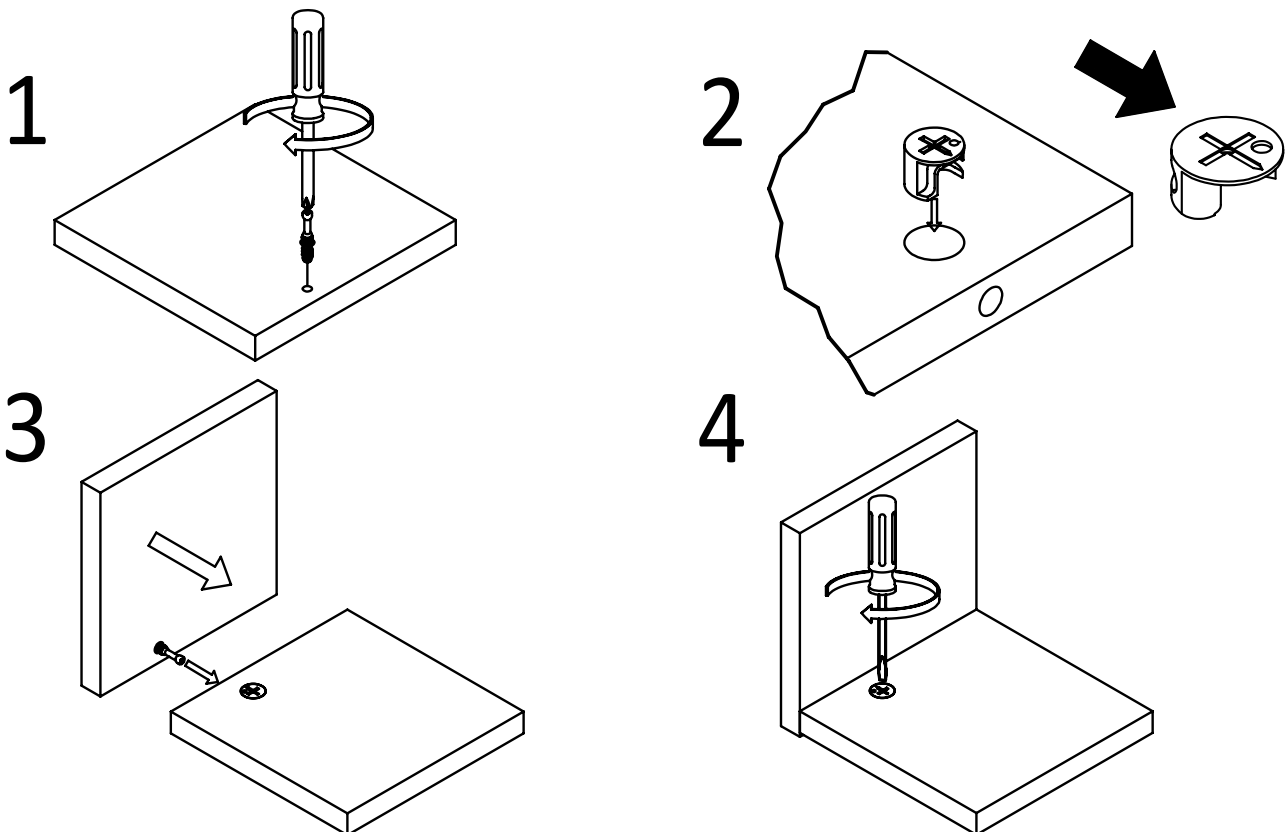

Board Identification

Not actual size

1

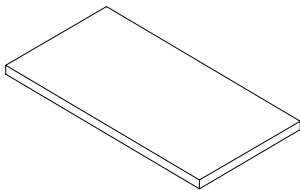

x1
T1642412010UD
TOP PANEL

2

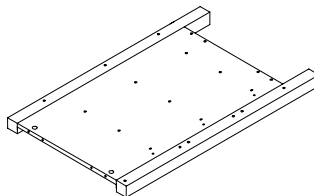

x1
T1642412020UD
LEFT SIDE PANEL

3

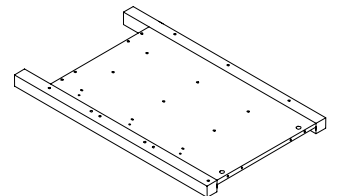

x1
T1642412030UD
RIGHT SIDE PANEL

4

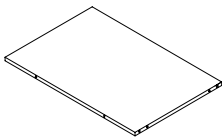

x1
T1642412040UD
BOTTOM PANEL

5

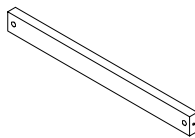

x1
T1642412050UD
TOP APRON

6

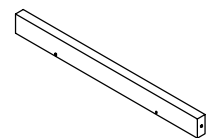

x1
T1642412060UD
BOTTOM APRON

7

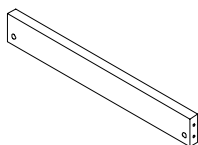

x2
T1642412070UD
CENTER APRON

8

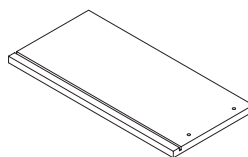

x3
T1642412080UD
LEFT DRAWER SIDE

9

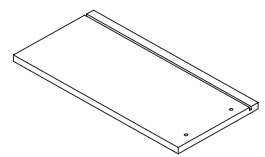

x3
T1642412090UD
RIGHT DRAWER SIDE

Board Identification Not actual size

10

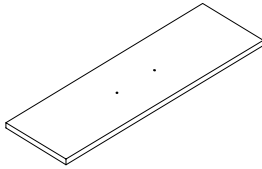

x3
T1642412100UD
FRONT DRAWER

11

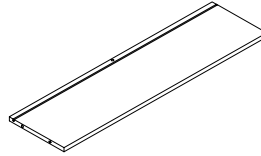

x3
T1642412110UD
BACK DRAWER

12

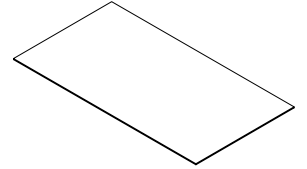

x3
T1642412120UD
DRAWER BOTTOM

13

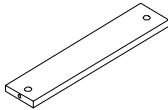

x3
T1642412130UD
DRAWER SUPPORT

14

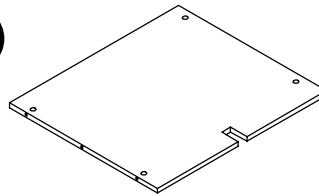

x1
T1642412140UD
BACK PANEL

Part List Not Actual size



x38
TUD0001
Cam Bolt

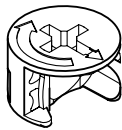

x38
TUD0002
Cam Lock
15-12

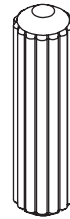

x16
TUD0004
DOWEL
M8 X 25

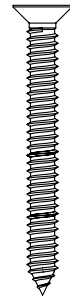

x12
TUD0009
CBS 4 x 38

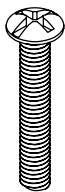

x6
TUD0070
PH M4 X 14



x42
TUD0008
CBS 3.5 x 16

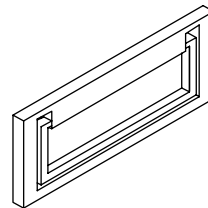

x3
TUD0064
BIG SQUARE
HANDLE

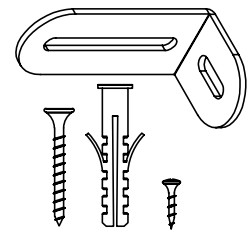

x1 SET
TUD0021
ANTI TIPPING KIT

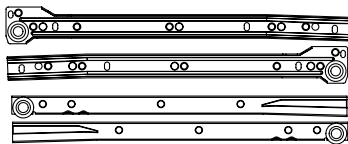

x3 SETS
TUD0017
DRAWER SLIDE
350 MM

Step 1

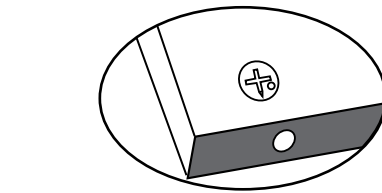
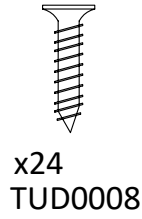
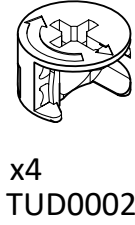
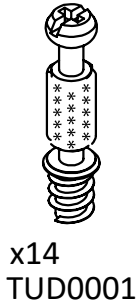
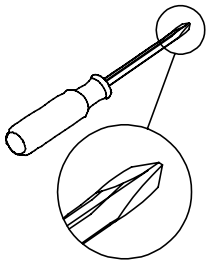

Proper orientation of CAM LOCK

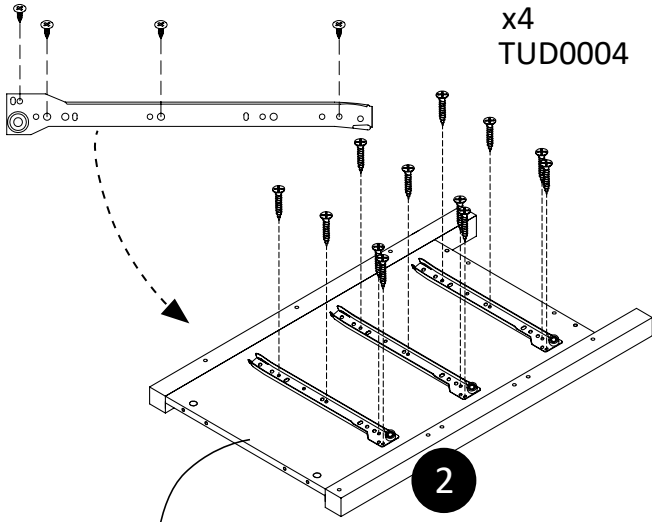
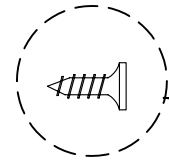
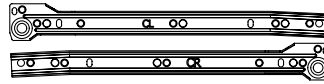
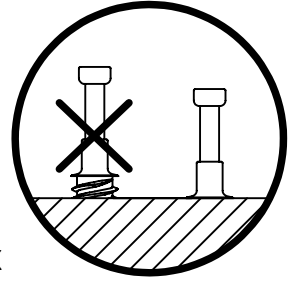

LEFT

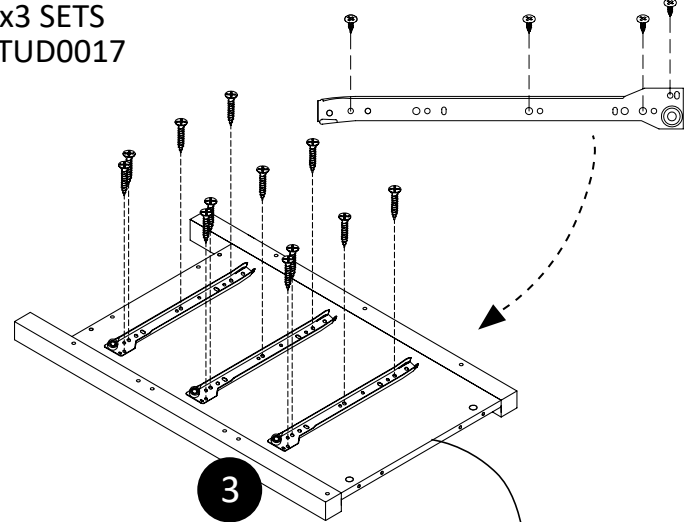

RIGHT

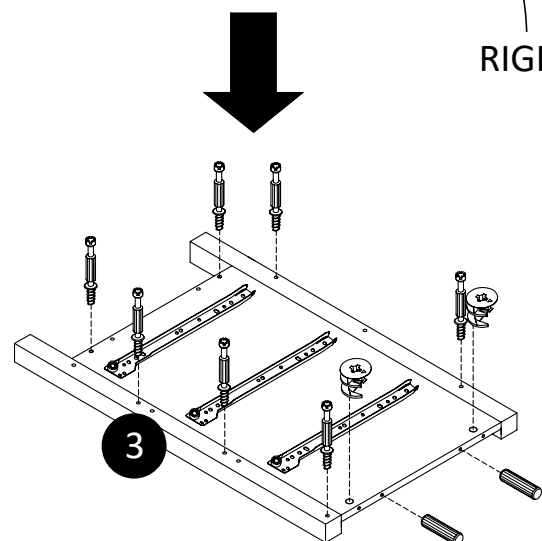
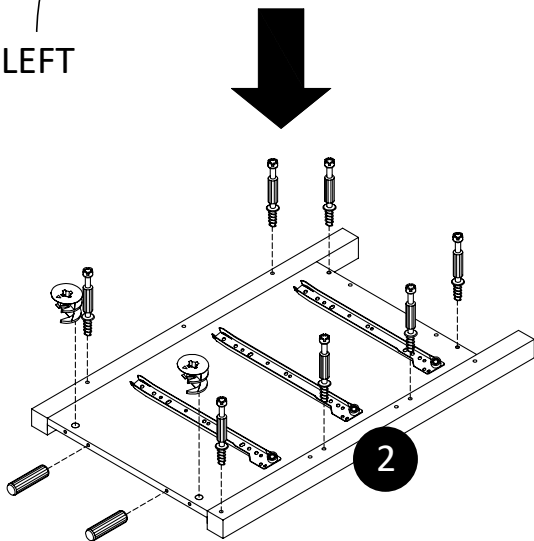

* raw edges are shaded

Step 2

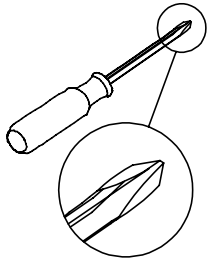

x4
TUD0001

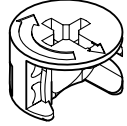

x6
TUD0002



x4
TUD0004

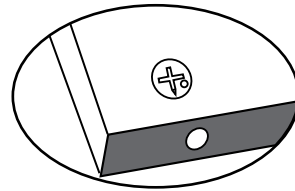

Proper orientation of CAM LOCK

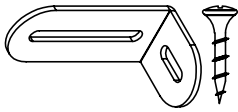
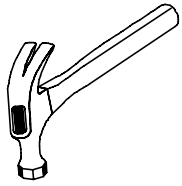
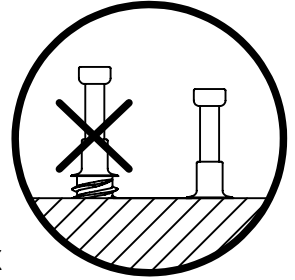

x1
TUD0021

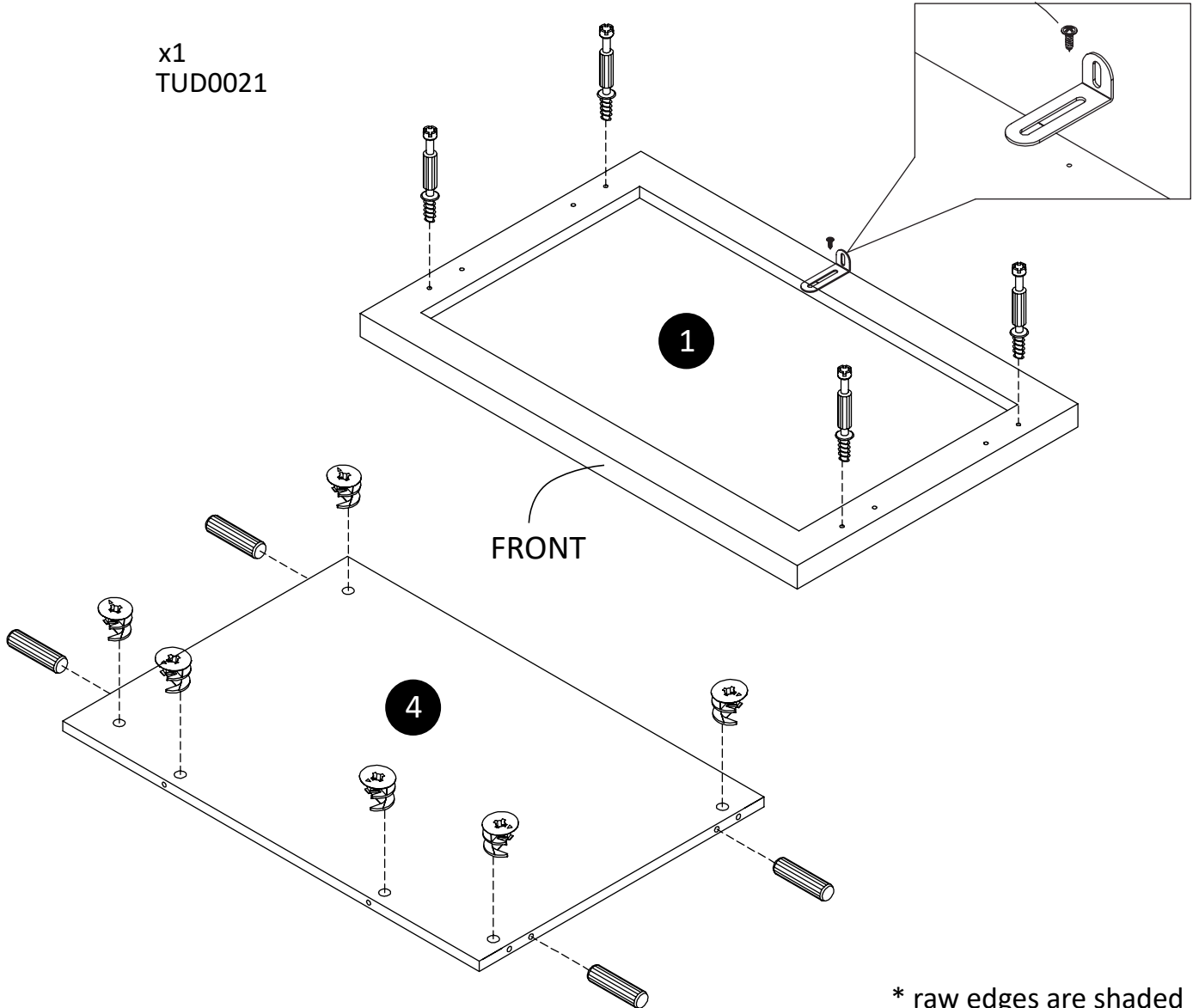
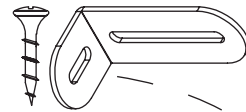

* raw edges are shaded

Step 3

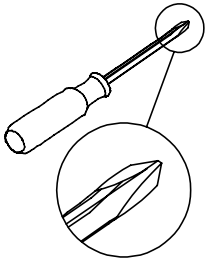

x2
TUD0001

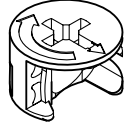

x10
TUD0002



x8
TUD0004

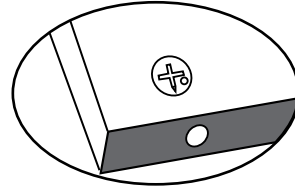

Proper orientation of CAM LOCK

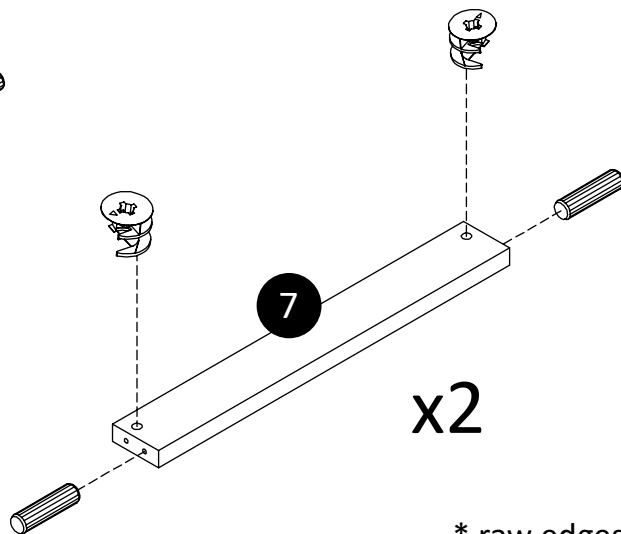
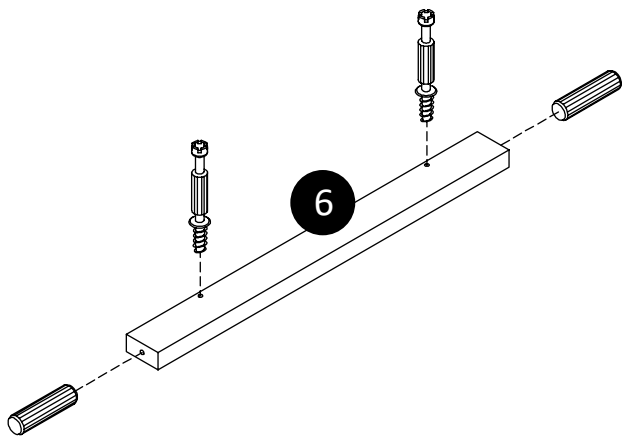
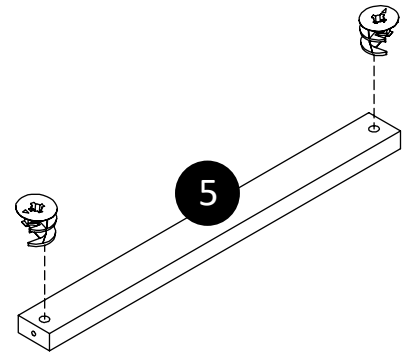
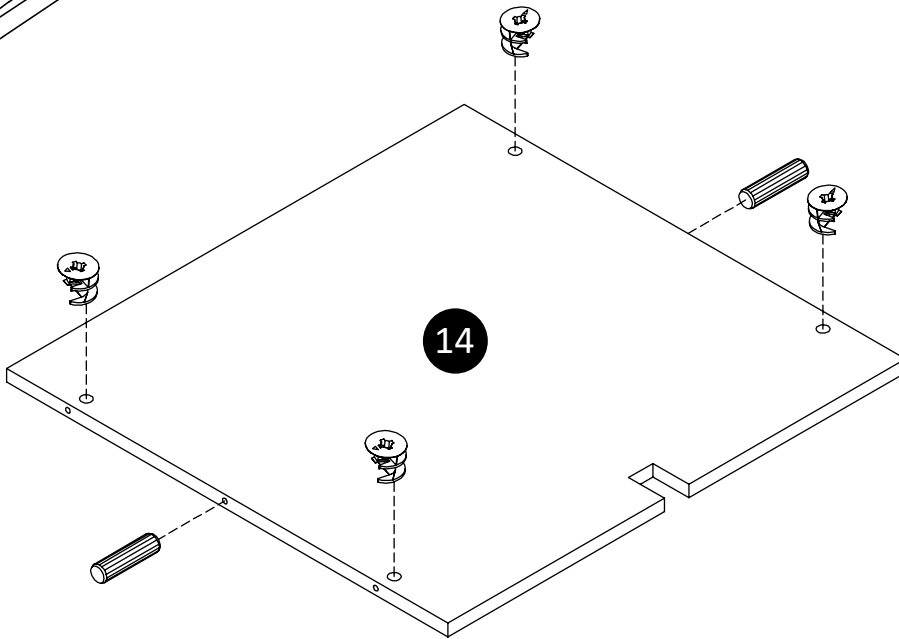
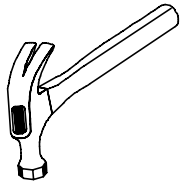
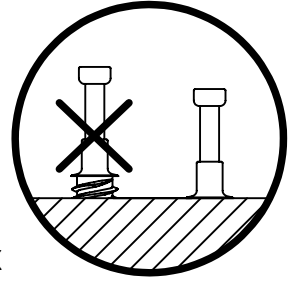

* raw edges are shaded

Step 4

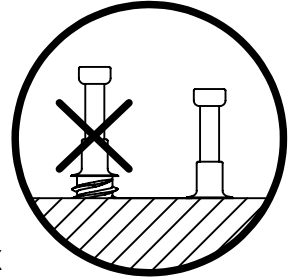
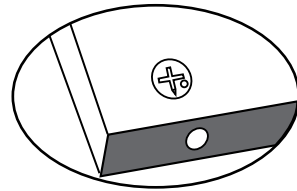
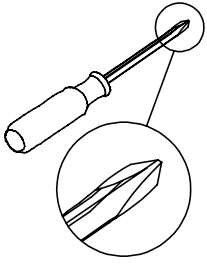

Proper orientation of CAM LOCK

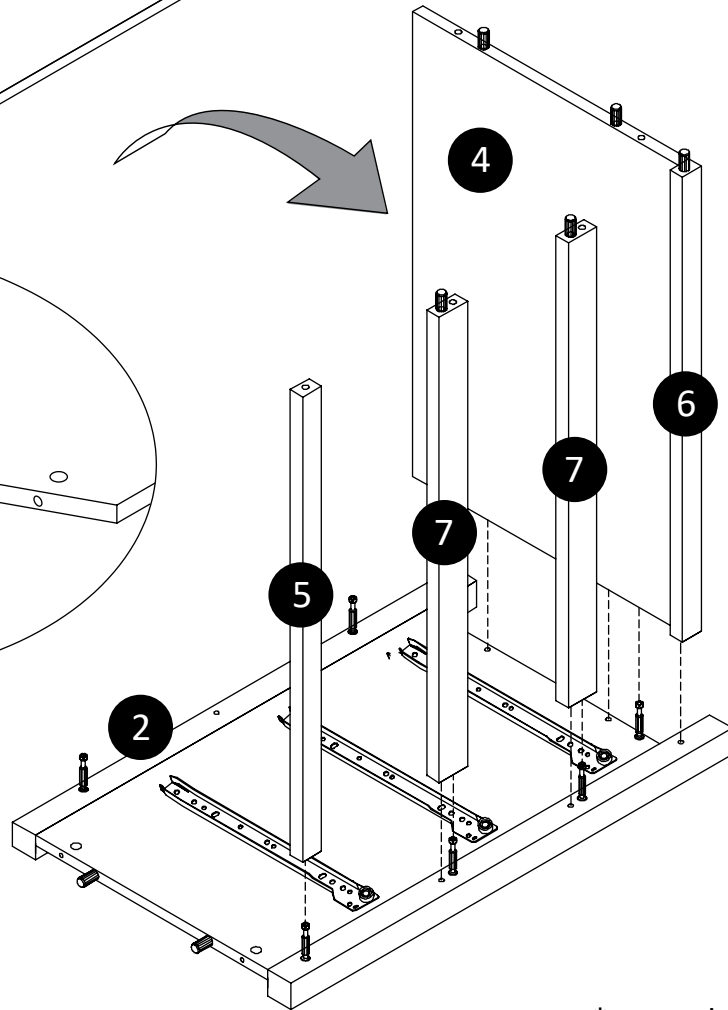
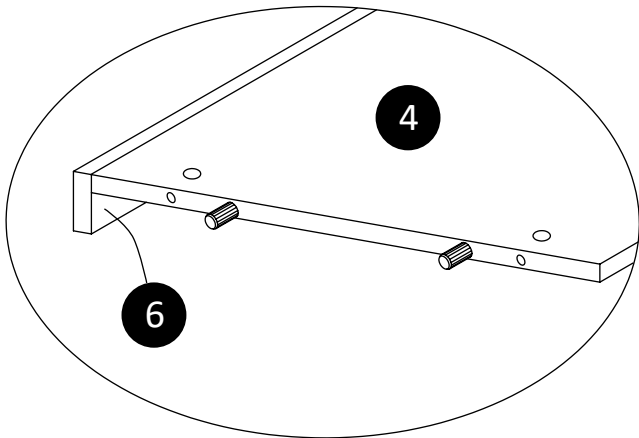
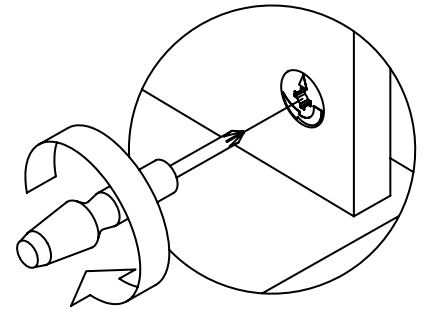
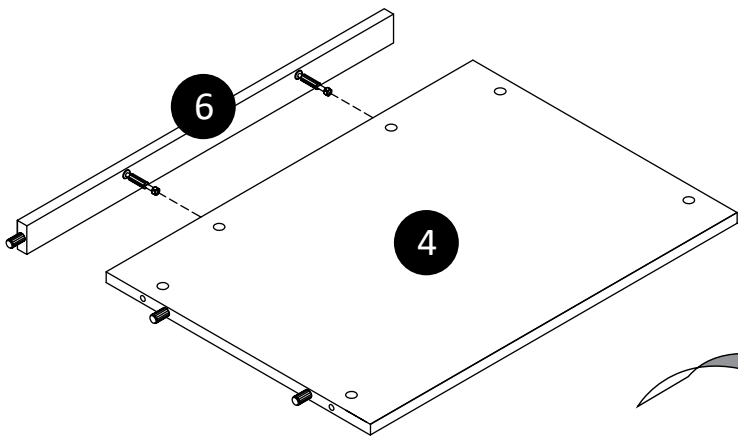

* raw edges are shaded

Step 5

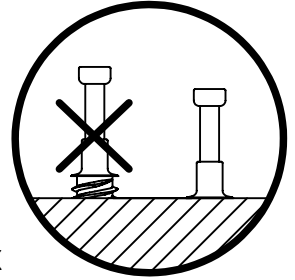
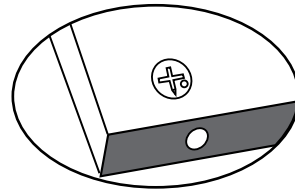
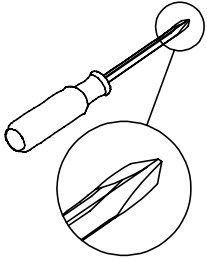

Proper orientation of CAM LOCK

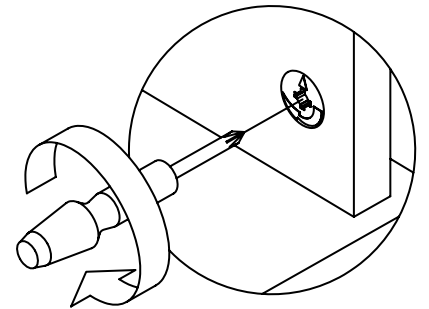
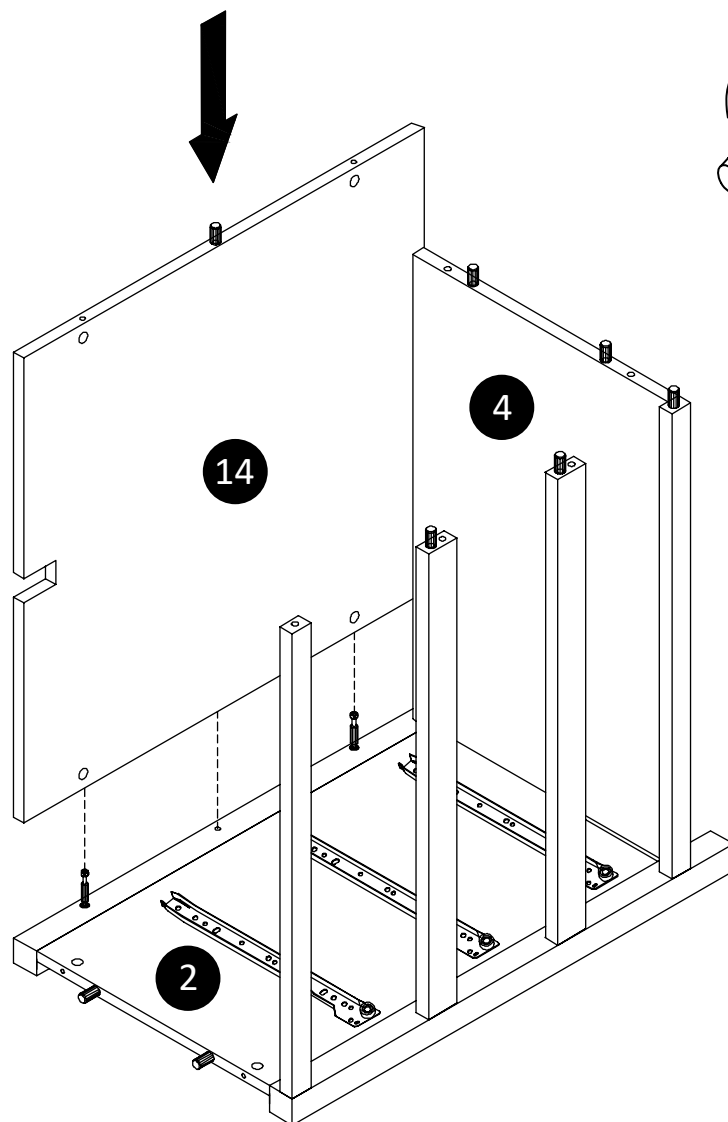

* raw edges are shaded

Step 6

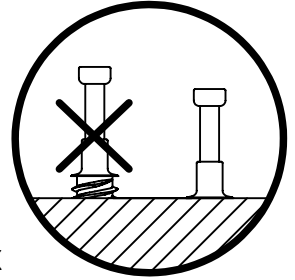
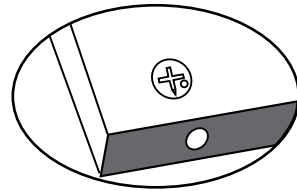
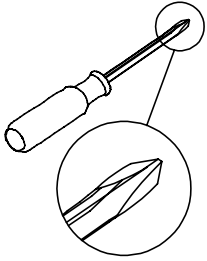

Proper orientation of CAM LOCK

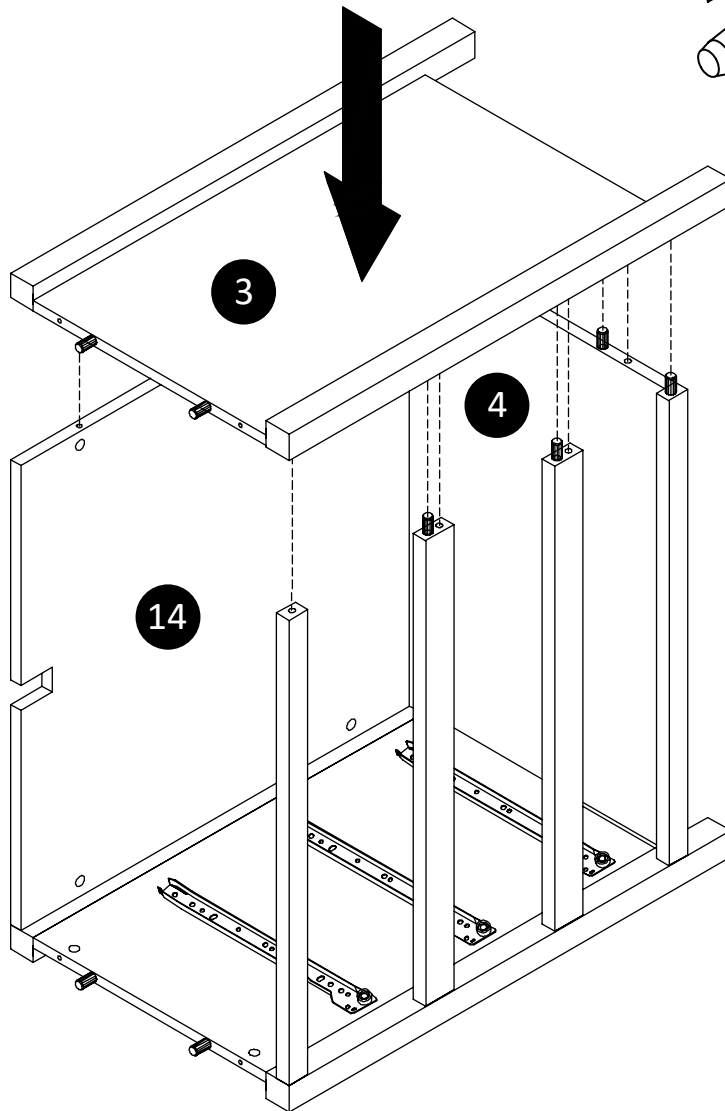
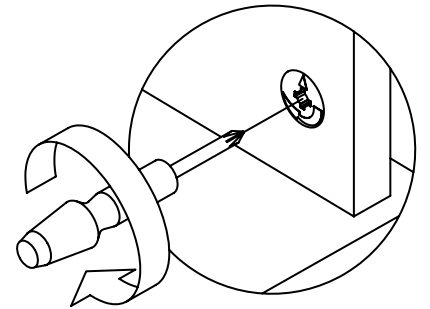

* raw edges are shaded



Step 7

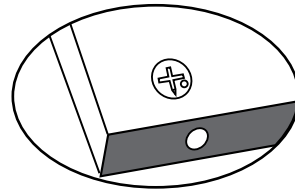
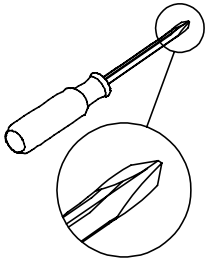

Proper orientation of CAM LOCK

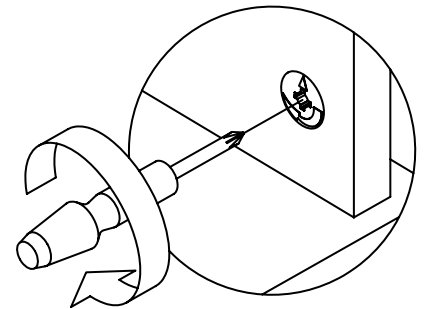
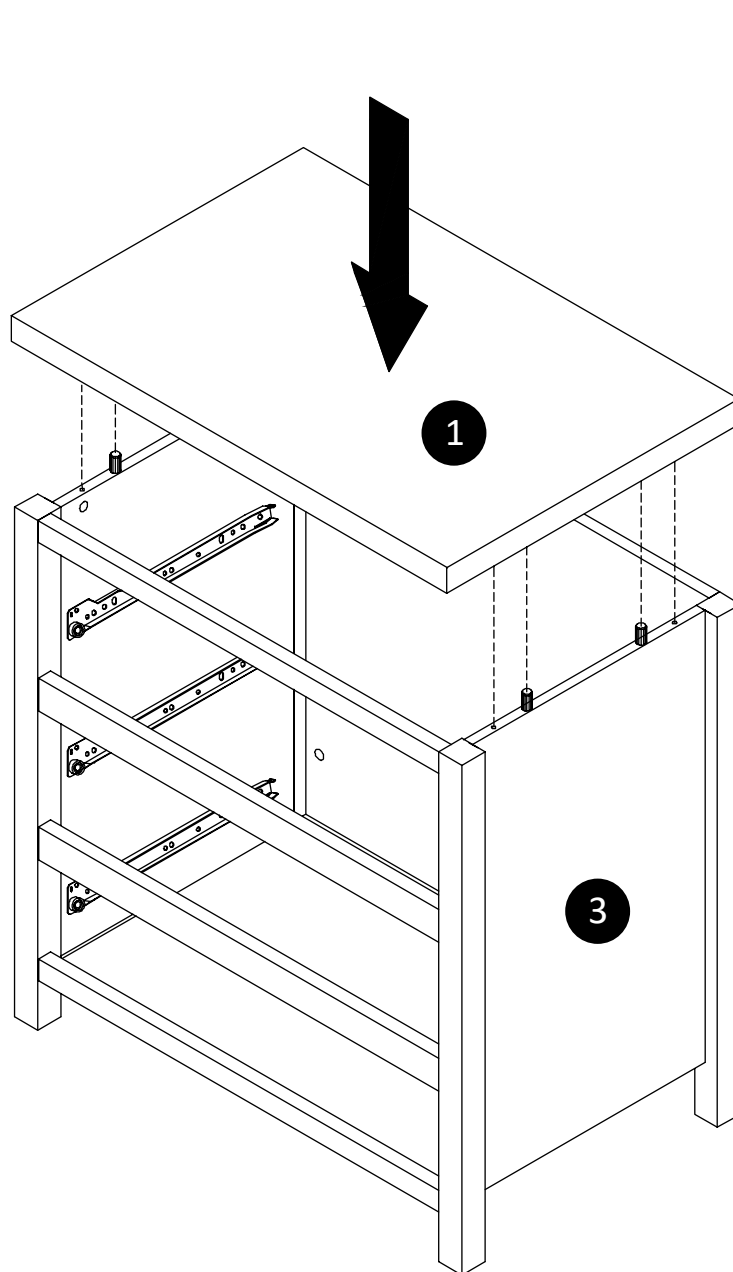
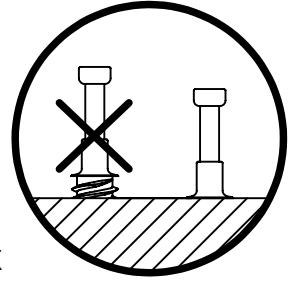

* raw edges are shaded

Step 8

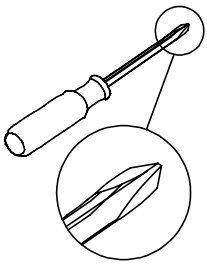

x18
TUD0002

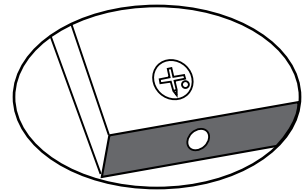

Proper orientation of CAM LOCK

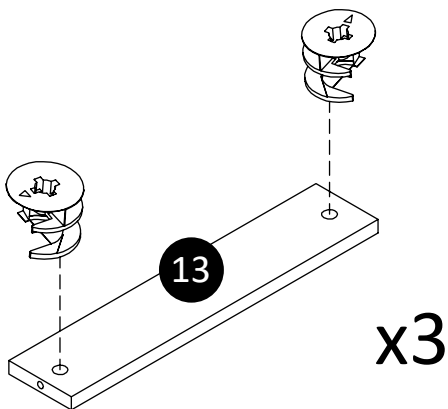
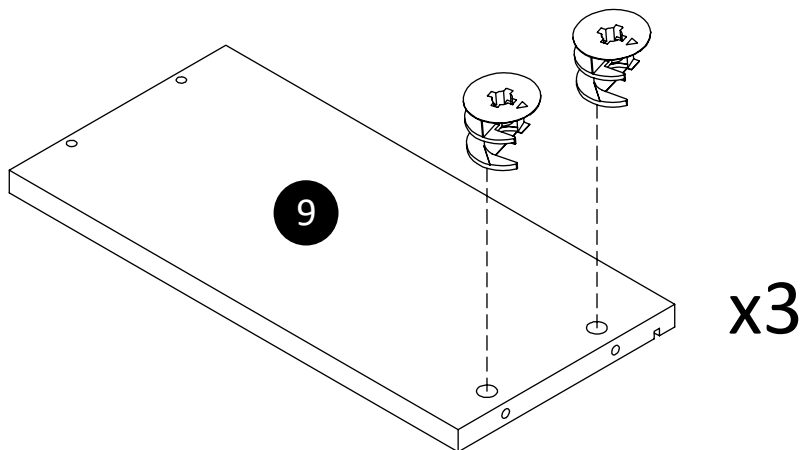
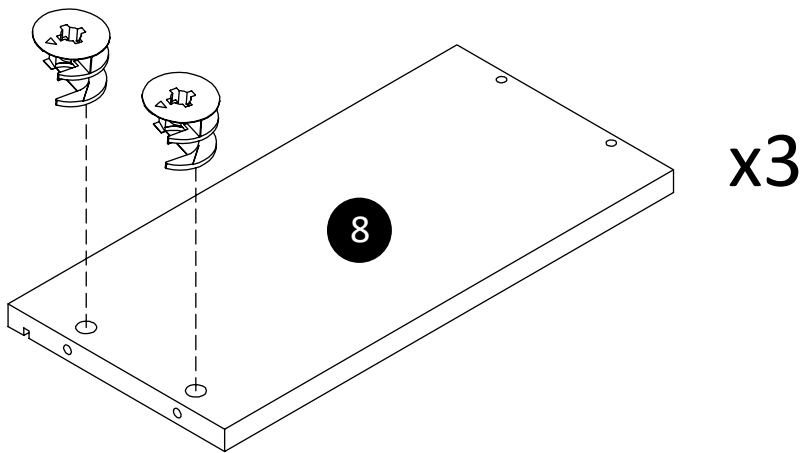

* raw edges are shaded



Step 9

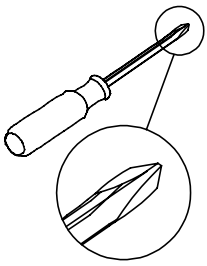

x18
TUD0001

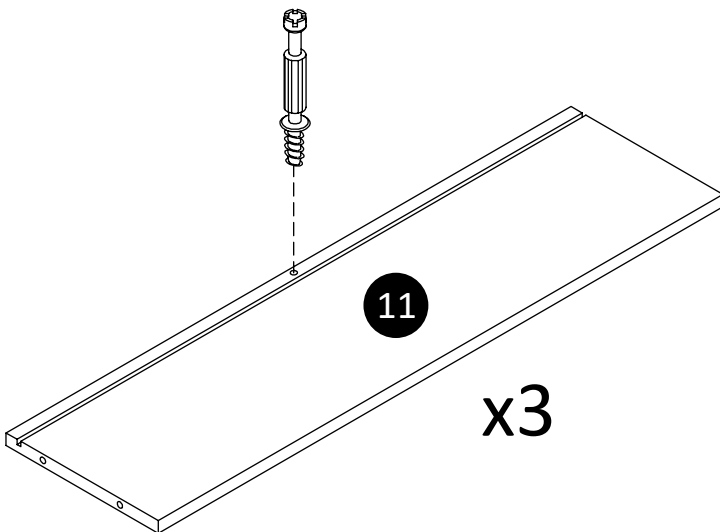
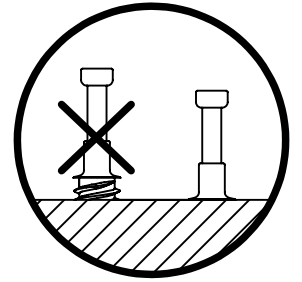

x3

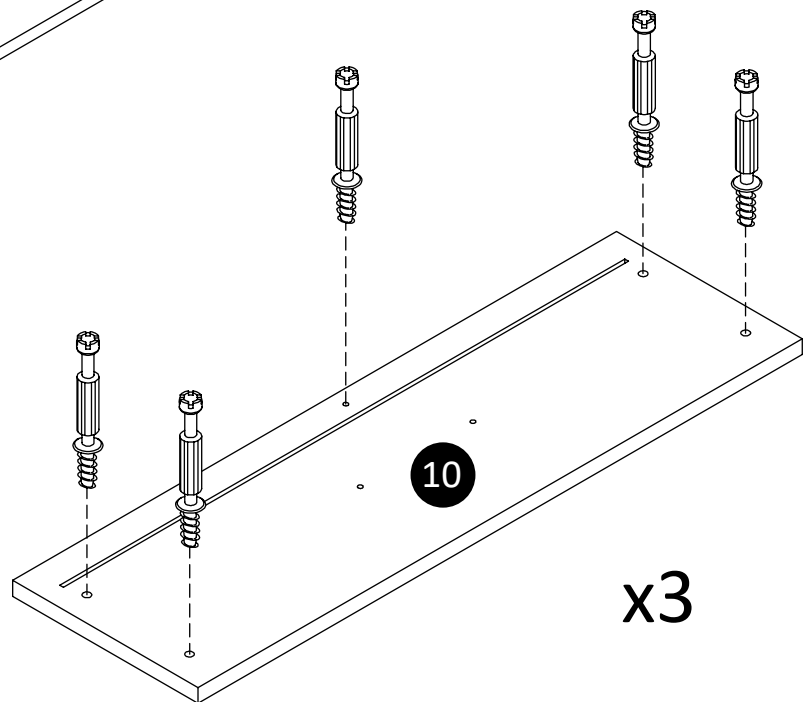

x3

* raw edges are shaded

Step 10

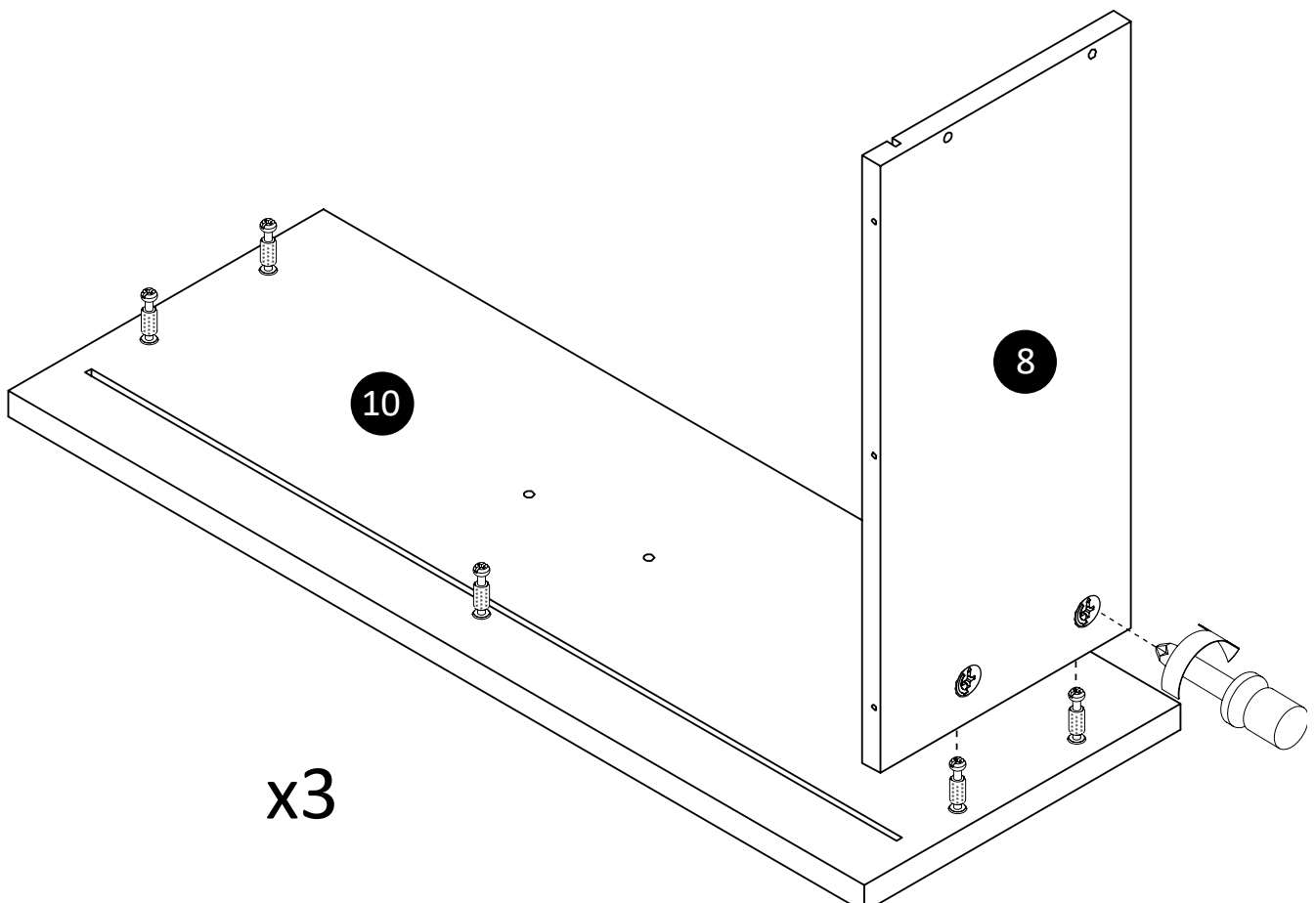
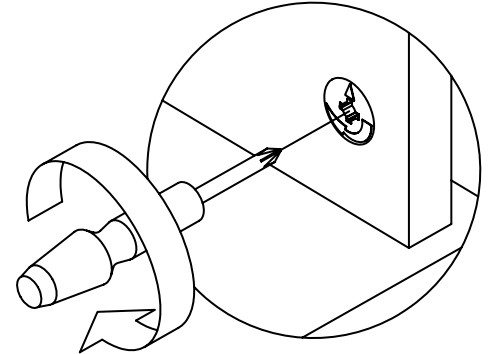
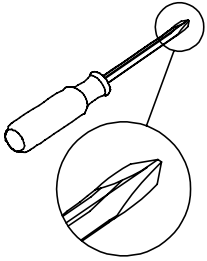

* raw edges are shaded

Step 11

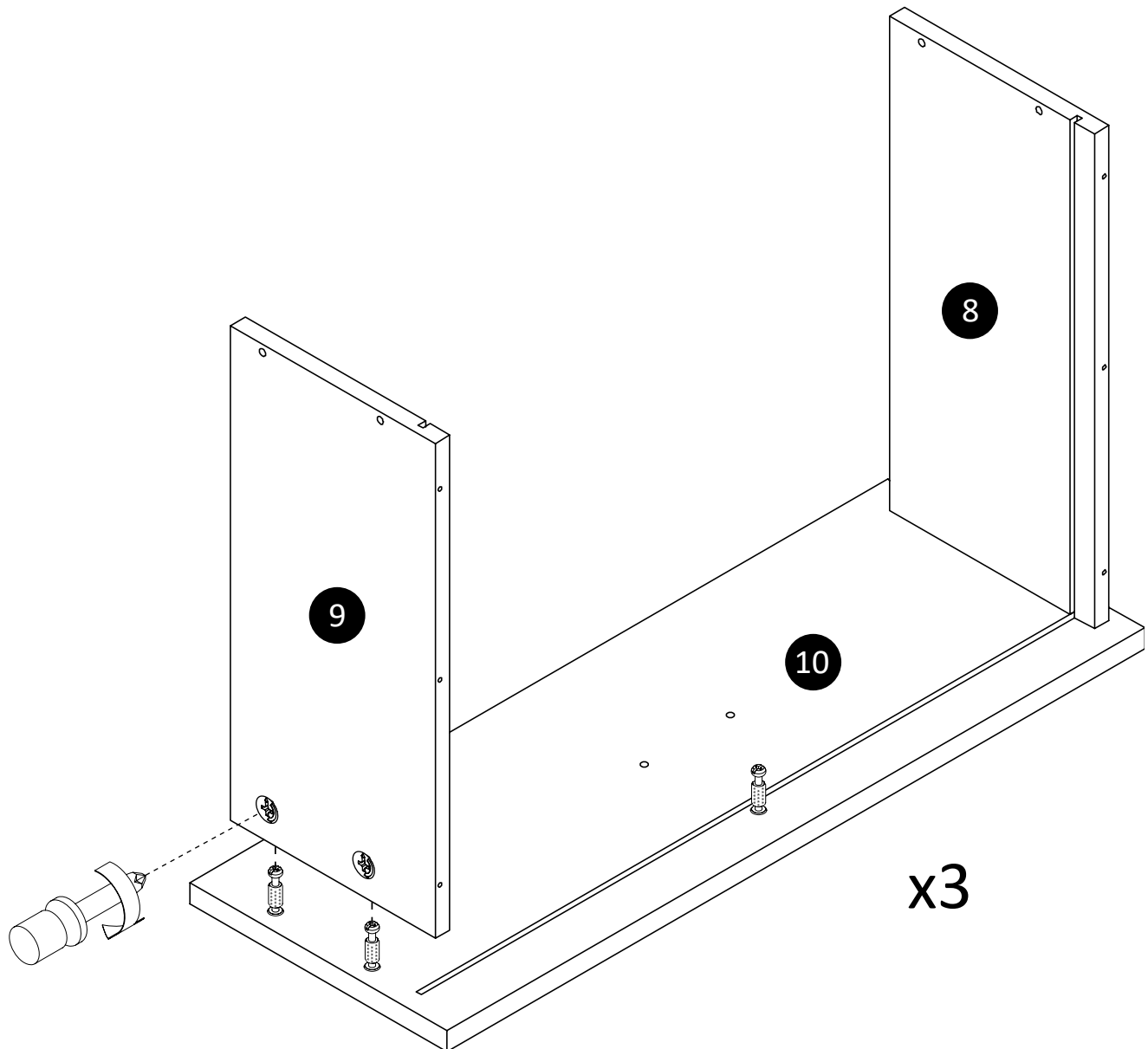
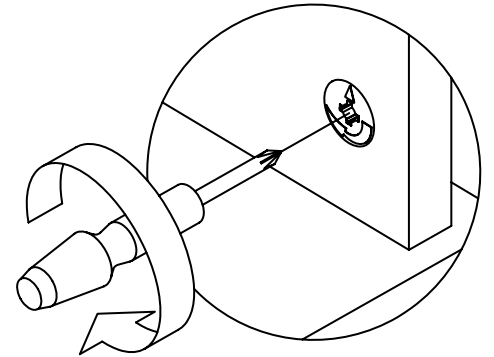
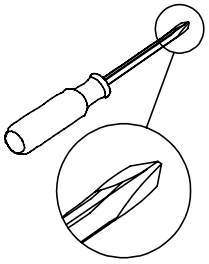

* raw edges are shaded

Step 12

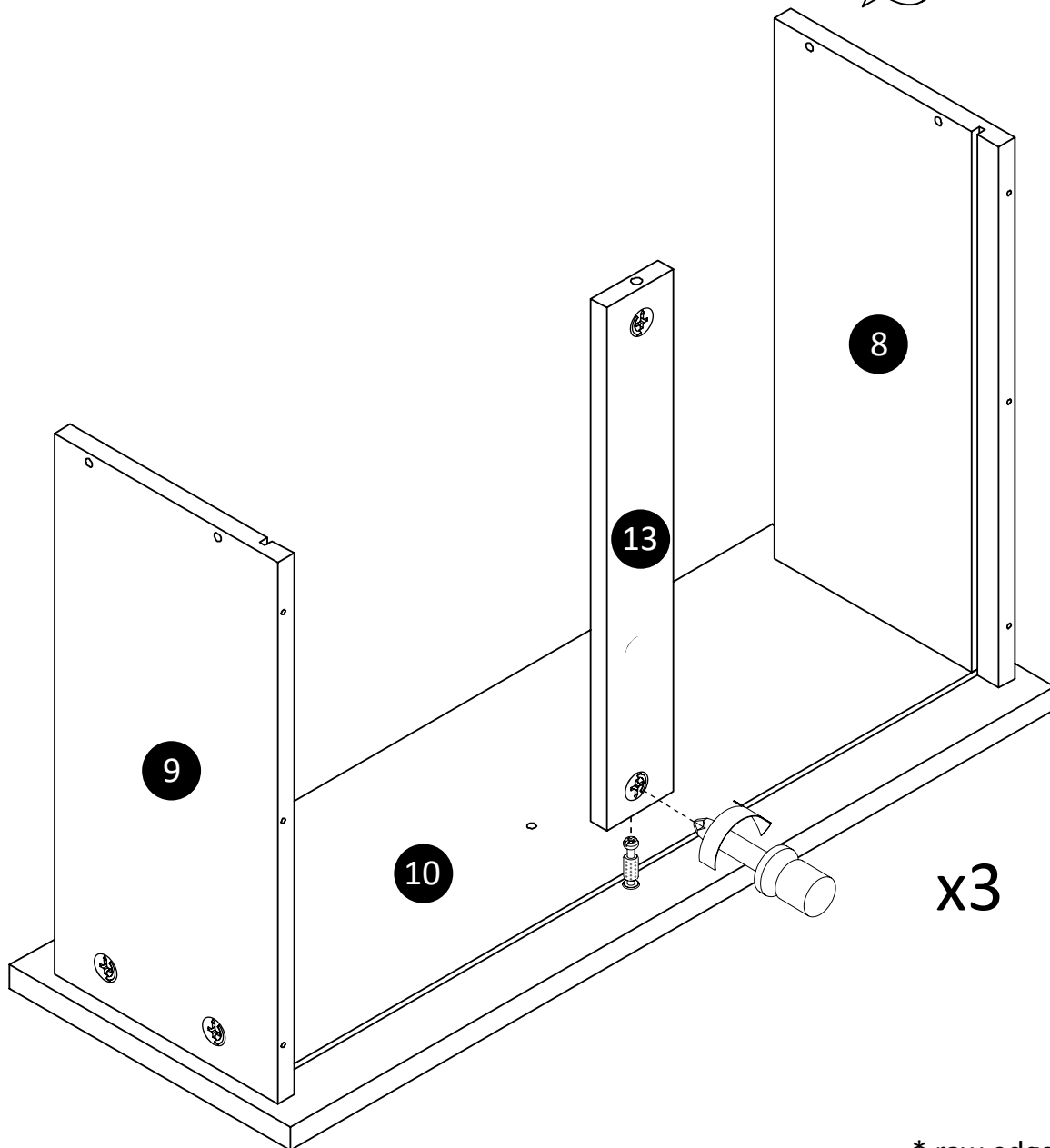
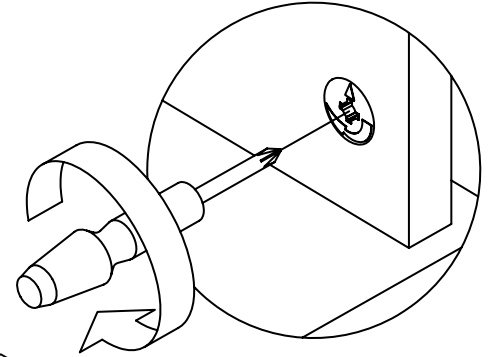
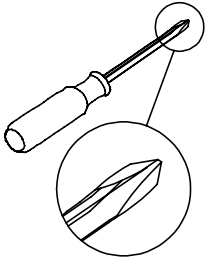

* raw edges are shaded

Step 13

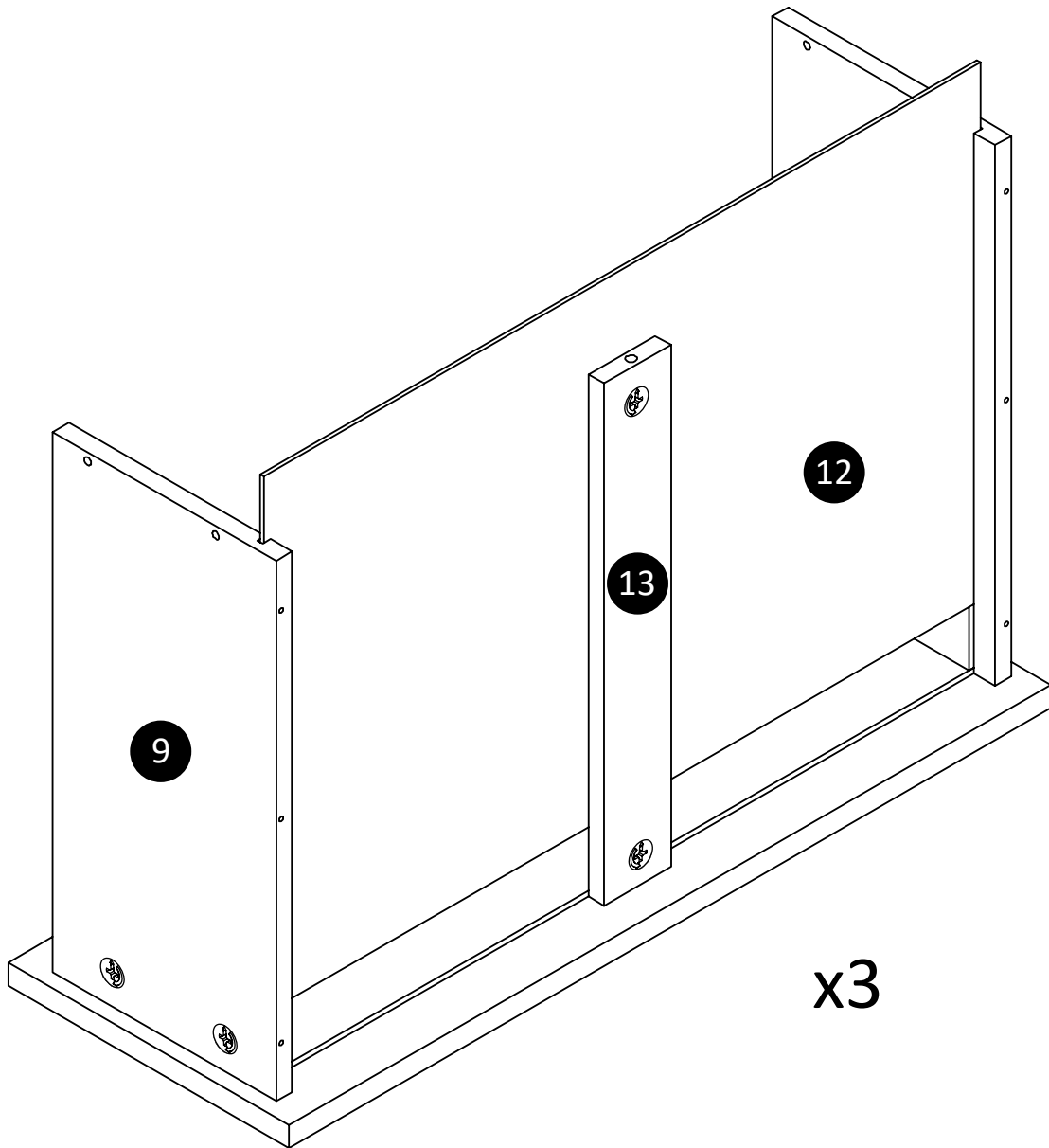

* raw edges are shaded

Step 14

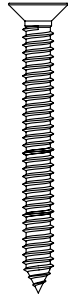
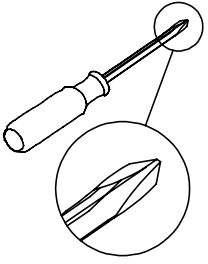

x12
TUD0009

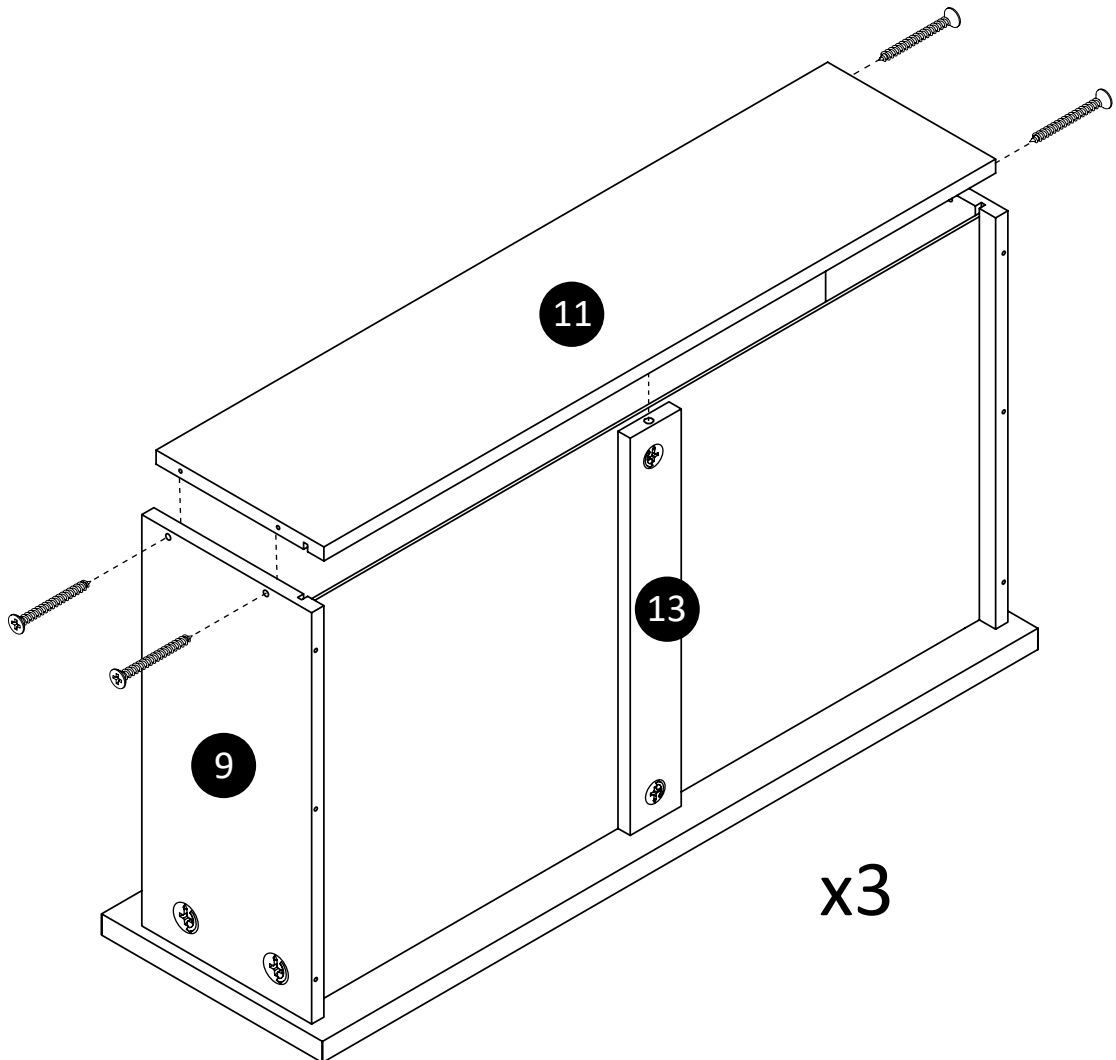

* raw edges are shaded

Step 15

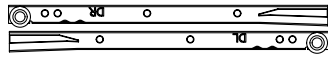
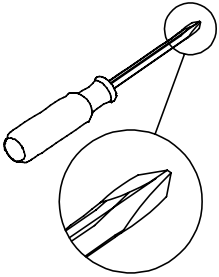

x3 SETS
TUD0016



x18
TUD0008

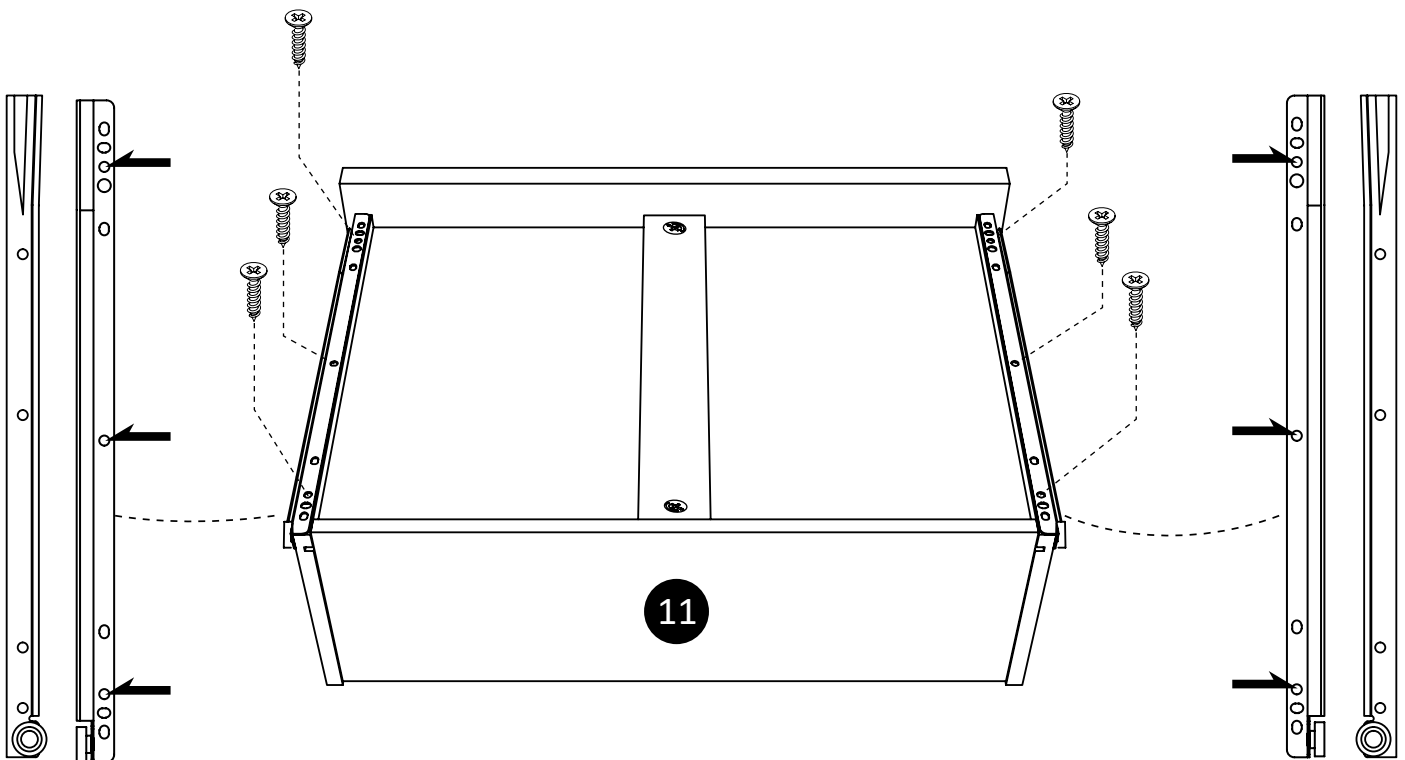

x3

* raw edges are shaded

Step 16

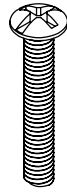
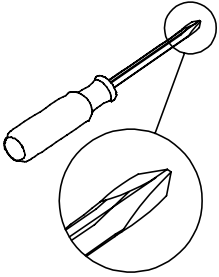

x6
TUD0070

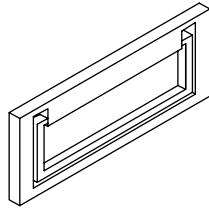

x3
TUD0064

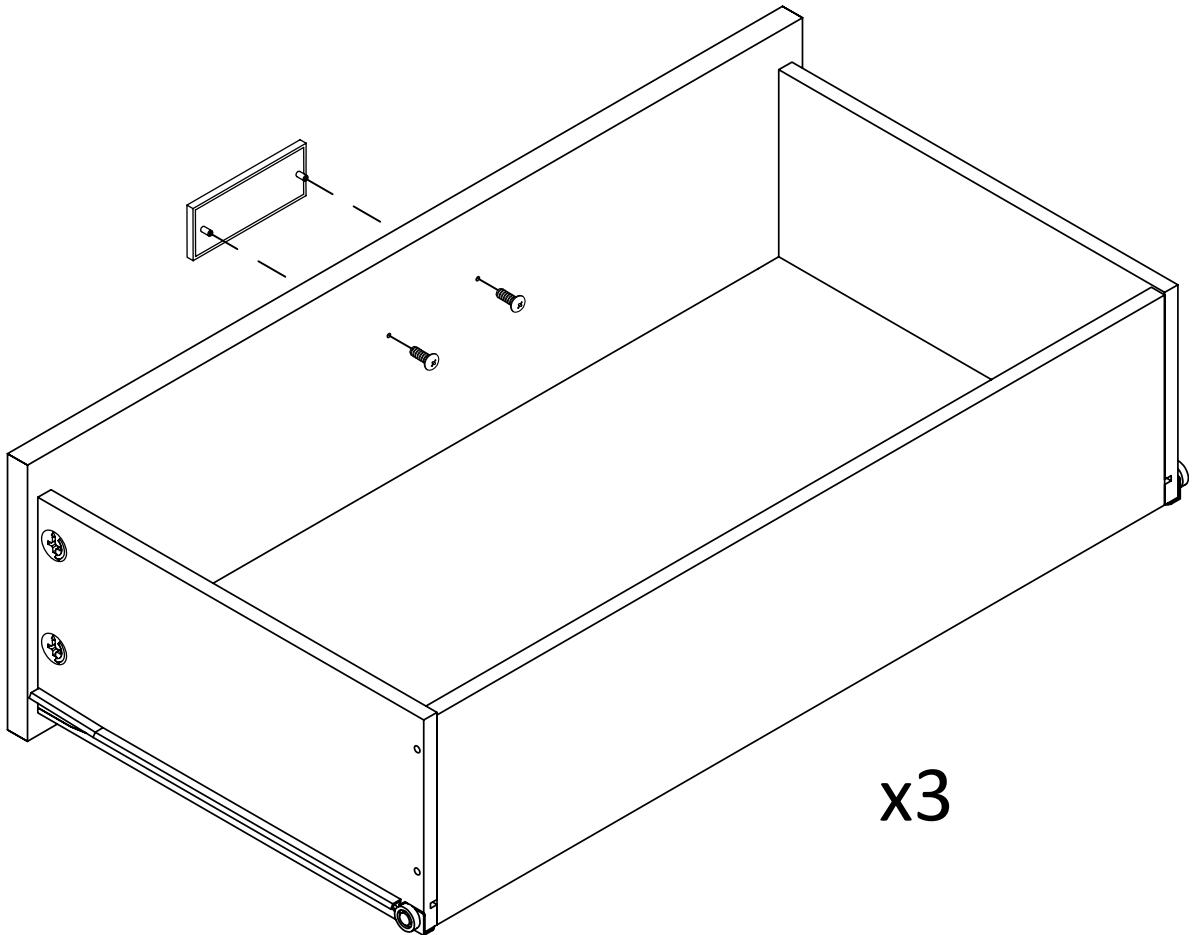

* raw edges are shaded

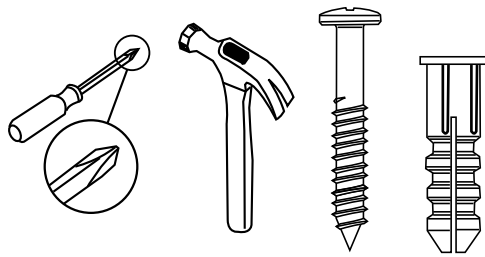

For Masonry, Concrete, or other wall materials:
Consult your local hardware store for appropriate anchors to securely attach the safety bracket.

IMPORTANT: THIS UNIT MUST BE SECURE TO THE WALL TO HELP PREVENT TIPOVER. FOLLOW THESE INSTRUCTIONS TO INSTALL THE ANTI-TIPPING SAFETY BRACKET PROVIDED WITH THIS PRODUCT.

WARNING

Serious or fatal crushing injuries can occur from furniture tipover.

To prevent tipover:

- * Install tipover restraint provided
- * place heaviest items in the lowest drawers
- * Unless specifically designed to accommodate, do not set TVs or other heavy objects on the top of this product
- * Never allow children to climb or hang on drawers, door, or shelves
- * Never open more than one drawer at a time

Use of tipover restraints may only reduce, but not eliminate the risk of tipover

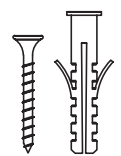

x1 set
TUD0021

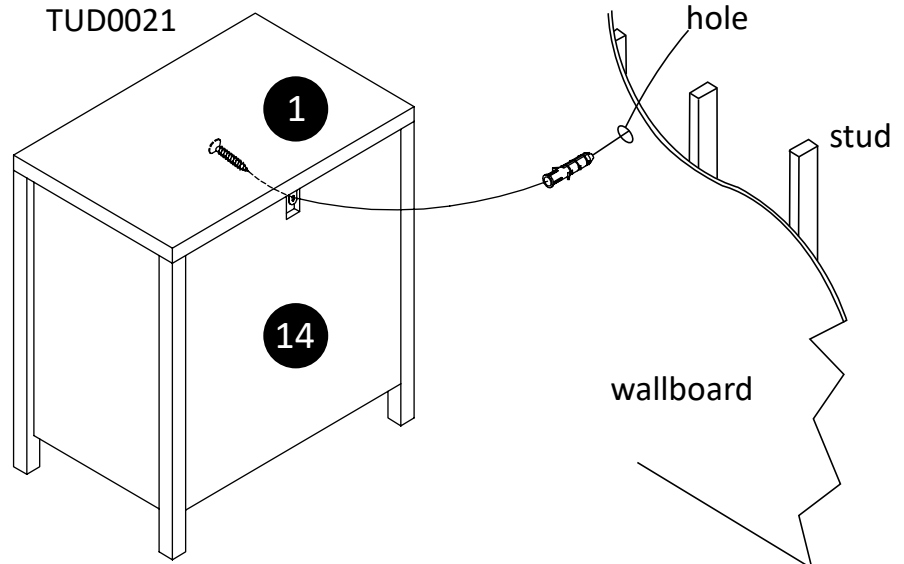

OPTION 1: Attachment into a wall stud (preferred method)

Using a stud finder, locate a stud in the wall. Place your unit against the wall, with the safety bracket aligned in this location.

To make driving the screw easier, you can drill a 1/8" diameter pilot hole (3mm) through the safety bracket into the stud.

Drive the screw through the safety bracket into the wall stud. Tighten the screw that was not fully tightened in step 5.

OPTION 2: Attachment into drywall

Locate your unit where desired against a wall and mark the wall through the safety bracket, then move your unit aside.

Drill a 3/16" diameter hole (5mm) into the wallboard. Tap the wall anchor into the hole until it is flush. Move your unit into location and fasten the wall bracket to the wall anchor with the screw.

Tighten the screw that was not fully tightened in step 5.

Step 17

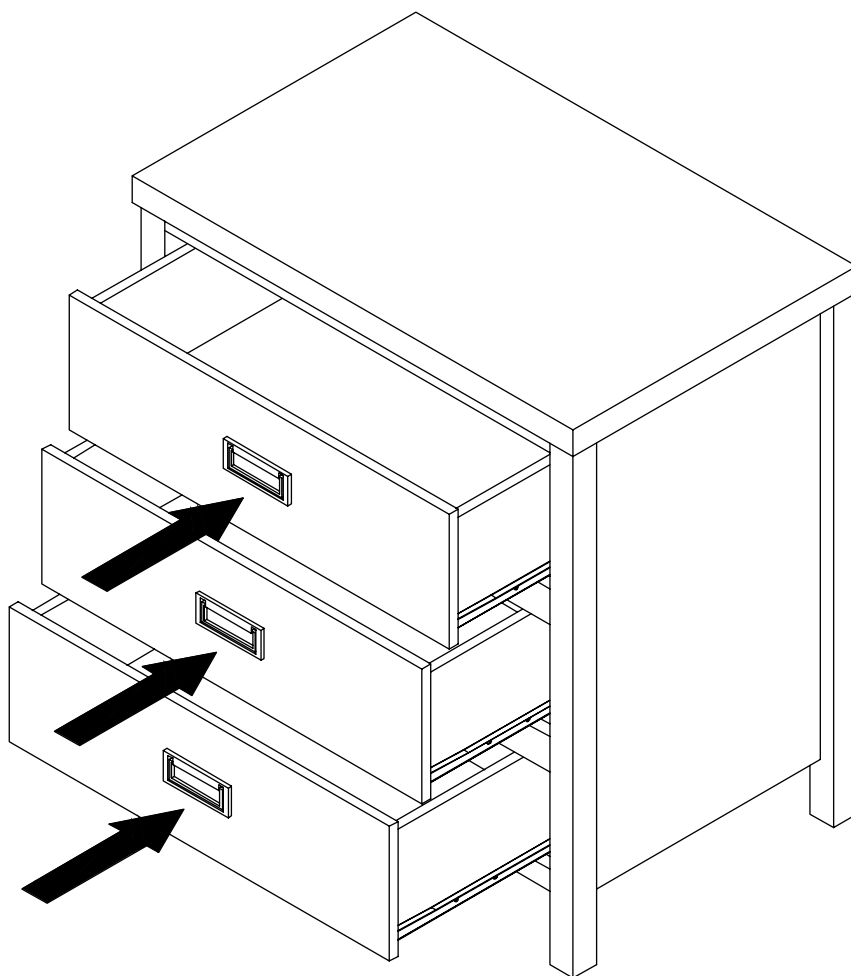

* raw edges are shaded

Maximum Loads

This unit has been designed to support the maximum loads shown. Exceeding these load limits could cause sagging, instability, product collapse, and/or serious injury.

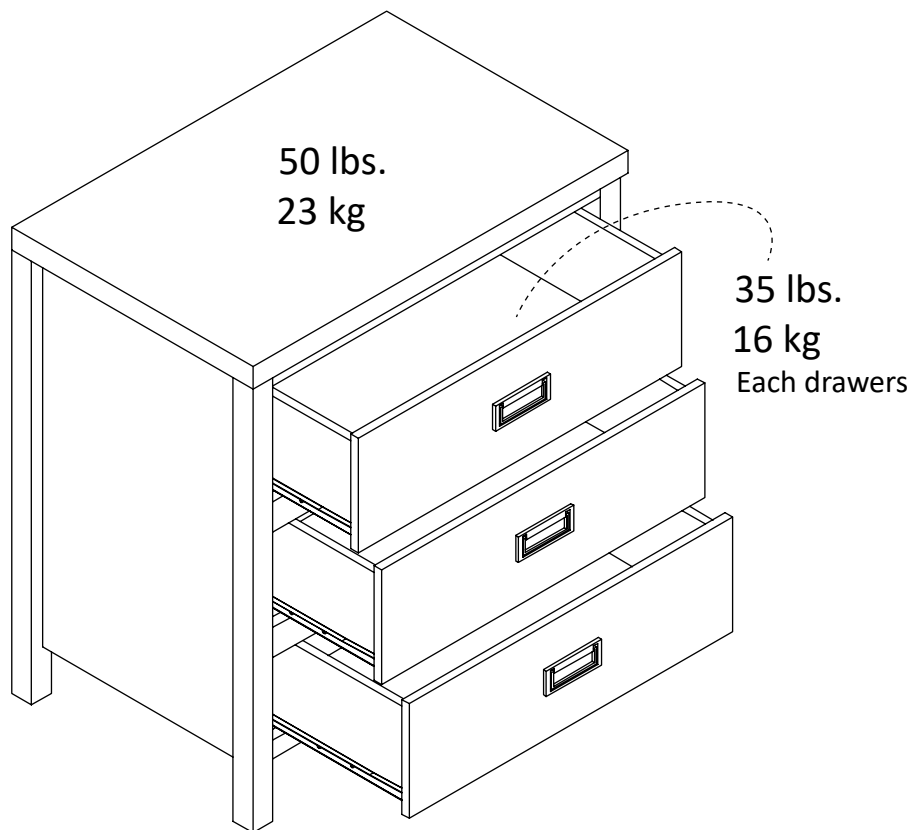

Warning: Risk of serious injury to person - do not place a television on this furniture. This furniture is not approved for use with a television.

Certificate of Conformity

1. This certificate applies to Dorel Home Furnishings, Inc. product identified by this instruction manual.
2. This certificate applies to compliance of this product with the CPSC Ban on Lead-Containing Paint (16 CFR 1303).
Dorel Home Furnishings, Inc.
3. This product is distributed by: 410 East First Street South,
Wright City, MO 63390
636-745-3351
4. Site of Manufacturer: Muar, Malaysia.
5. See front page of instruction manual for date of manufacturer.



Register your product to receive the following:



- * New trend details -sneak peek on what's new
- * Surveys -have a voice within our community
- * Exclusive deals and discount codes
- * Quick and easy replacement part service

To register your product, visit littleseedskids.com

5 Star Rating



Visit your local retailer's website, rate your purchased product and leave us some feedback!

We would like to extend a big "Thank You" to all of our customers for taking the time to assemble this Little Seeds product, and to give us your valuable feedback.

Thank You!





THANK YOU for your business.



Your feedback and 5-star review is important to us!



If you are happy with this product, please review on the site you purchased it from.



If your product has issues, please contact us so that we can fix them.

Please note, we do not have control over how shipping carriers treat our products and could cause damage to your order. If your product is damaged, please contact us for help.

**1-800-489-3351 • Customer.service@dorel.com
Customer Service Hours: 9am - 5pm Central Time (CST)
Monday through Friday**



Español

Cubierta Delantera

Busque en el interior del manual de montaje
Búsquenos!

página 2

Conserve este manual de montaje para futuras consultas.
Se recomienda dos adultos para el montaje.
Este producto no es para uso comercial.

No Regrese este producto! Para piezas perdidas o rotas.

Visitar: littleseedskids.com

Llámenos al: 1-800-489-3351 (Gratis) Lunes - Viernes 9am - 5pm CST

Seguir little seeds en

Consejos Útiles (página 3)

- Abra su artículo en el área donde usted planea utilizarlo para evitar levantar y moverlo menos
- Identificar, ordenar y contar las piezas antes de intentar ensamblar
- Las clavijas de compresión se golpean con un martillo
- Las diapositivas están marcadas con una R (derecha) y L (izquierda) para la colocación correcta
- Asegúrese de que siempre este el punto localizado en la parte superior de bloqueador de leva este volteado hacia borde exterior
- Utilizar todos los clavos para el panel de atrás y distribuirlos por igual
- El panel de atrás debe utilizarse para asegurarse de que la unidad quede fija y firme
- No use químicas fuertes ni limpiadores abrasivos en este artículo
- Nunca empuje, tire ni arrastre los muebles

Lista de (página 4)

antes de que empieces

Lea cuidadosamente cada paso y siga el orden apropiado

Separar y contar todas las piezas y el hardware

Darse suficiente espacio para el proceso de montaje

Tienen las siguientes herramientas: destornillador de cabeza plana, # 2 destornillador philips cabeza y martillo

Precaución: si utiliza un taladro eléctrico o un destornillador eléctrico para atornillar, tenga cuidado de frenar y parar cuando el tornillo esté apretado. Si no lo hace, se puede quitar el tornillo

Sistema de sujeción de cerradura de leva

Este sistema de fijación de la leva se utilizará durante todo el proceso de montaje

Identificación de la Junta (página 5 y 6)

Tamaño no real

Lista de piezas (página 7 hasta 23)

Tamaño no real

Español

Página 24

Para mampostería, hormigón u otros materiales de pared:

Consulte en su ferretería local los anclajes apropiados para sujetar de forma segura el soporte de seguridad.

IMPORTANTE: ESTA UNIDAD DEBE ESTAR SEGURA EN LA PARED PARA AYUDAR A PREVENIR AL TIPOVER. SIGA ESTAS INSTRUCCIONES PARA INSTALAR EL SOPORTE DE SEGURIDAD ANTIDISCIPLINADOR PROPORCIONADO CON ESTE PRODUCTO.

ADVERTENCIA

Lesiones por aplastamiento graves o fatales puede ocurrir desde la punta del mueble. Para evitar volcar:

- * Instale la restricción de vuelco provista
- * coloque los artículos más pesados en los cajones más bajos
- * A menos que esté específicamente diseñado para acomodar, no instale televisores u otros objetos pesados en la parte superior de este producto
- * Nunca permita que los niños trepen o cuelguen de los cajones, puertas o estanterías
- * Nunca abra más de un cajón a la vez

El uso de restricciones sobre volteos solo puede reducir, pero no eliminar, el riesgo de vuelco

OPCIÓN 1: Adjunto a un montante de pared (método preferido)

Usando un buscador de pernos, ubique un perno en la pared. Coloque su unidad contra la pared, con el soporte de seguridad alineado en esta ubicación.

Para facilitar el manejo del tornillo, puede perforar un orificio piloto de 1/8 "de diámetro (3 mm) a través de la seguridad

soporte en el perno.

Introduzca el tornillo a través del soporte de seguridad en el montante de la pared. Apretar el tornillo que no estaba completamente

Tightened.

OPCIÓN 2: fijación al panel de yeso

Ubique su unidad donde desee contra una pared y marque la pared a través del soporte de seguridad, luego mueva tu unidad a un lado.

Taladre un orificio de 3/16 "de diámetro (5 mm) en el tablero. Toque el anclaje de pared en el orificio hasta que quede al ras. Mueva su unidad a su ubicación y ajuste el soporte de pared al anclaje de pared con el tornillo.

Apriete el tornillo que no estaba completamente apretado.

Página 27

ETIQUETA DE PRECAUCIÓN

CARGA MAXIMA

Esta unidad ha sido diseñada para soportar la carga máxima anotada. El exceder estos límites puede causar inestabilidad, colapsarse y/o causar serias lesiones.

Advertencia: asegúrese de quitar todos los objetos antes de mover la unidad ensamblada. La unidad debe ser levantada por más de una persona, no arrastrada o empujada. No hacerlo así lo hará causar daño al producto, inestabilidad, colapso del producto y / o lesiones graves.

Página 28

Registre su producto para recibir lo siguiente:

- * Nuevos detalles sobre las tendencias - Sneek echa un vistazo a lo nuevo
 - * Encuestas - tener una voz dentro de nuestra comunidad
 - * Ofertas exclusivas y códigos de descuento
- Servicio de piezas de repuesto rápido y fácil

Para registrar su producto, visite Ameriwoodhome.com

5 estrellas

Visite el sitio web de su distribuidor local, califique su producto comprado y déjenos algunos comentarios!

Nos gustaría extender un gran “Gracias” a todos nuestros clientes por tomarse el tiempo para montar este producto Ameriwood Home, y para darnos sus valiosos comentarios

Gracias!

Página 29

Gracias por hacer negocios.

¡Tu opinión y la de 5 estrellas es importante para nosotros!

Si está satisfecho con este producto, revise en el sitio donde lo compró.

Si su producto tiene problemas, contáctenos para que podamos solucionarlo.

Tenga en cuenta que no tenemos control sobre la forma en que los transportistas tratan nuestros productos y podrían dañar su pedido. Si su producto está dañado, póngase en contacto con nosotros para obtener ayuda.

Français

Capot Avant

Regardez à l'intérieur du manuel d'assemblage
Búsquenos!

Page 2

Gardez ce manuel d'assemblage pour référence ultérieure.
Deux adultes sont recommandés pour l'assemblage.
Ce produit n'est pas destiné à un usage commercial.

Non Retournez ce produit! Pour les pièces perdues ou cassées.

Visiter: littleseedskids.com

Appelez-nous au 1-800-489-3351 (gratuit) du lundi au vendredi de 9h à 17h CST

Suivre les petites graines sur

Conseils utiles (page 3)

- Ouvrez votre article dans la zone où vous prévoyez de l'utiliser pour éviter de le soulever et de le déplacer moins
- Identifier, trier et compter les pièces avant de tenter d'assembler
- Les chevilles de compression sont frappées d'un marteau
- Les diapositives sont marquées d'un R (à droite) et de L (gauche) pour le placement correct
- Assurez-vous que ce soit toujours le point de localisation sur le haut du caméra ceci tourné vers le bord extérieur
- Utilisez tous les ongles pour le panneau arrière et distribuez-les également
- Le panneau arrière doit être utilisé pour s'assurer que l'appareil est fixe et ferme.
- Ne pas utiliser de produits chimiques solides ou abrasifs dans cet article
- Ne jamais pousser, tirer ou faire glisser des meubles

Liste de (page 4)

avant de commencer

Lisez attentivement chaque étape et suivez l'ordre approprié

Séparez et comptez toutes les pièces et le matériel

Donner suffisamment d'espace pour le processus d'assemblage

Ils ont les outils suivants: tournevis à tête plate, tournevis à tête croisée n° 2 et marteau

Attention: si vous utilisez une perceuse électrique ou un tournevis électrique à vis, veuillez à vous arrêter et à vous arrêter lorsque la vis est serrée. Si ce n'est pas le cas, la vis peut être retirée

Système de régler le verrou de came

Ce système de verrouillage de caméra sera utilisé tout au long du processus d'assemblage

Identification du Conceil (page 5 et 6)

Pas de taille réelle

Liste des pièces (page 7 jusqu'à ce que 23)

Pas de taille réelle

Français

page 25

Pour la maçonnerie, le béton ou d'autres matériaux muraux:

Consultez votre quincaillier local pour obtenir les ancrages appropriés afin de fixer solidement le support de sécurité.

IMPORTANT: CET APPAREIL DOIT ÊTRE SÉCURISÉ AU MUR POUR AIDER À PRÉVENIR TIPOVER. SUIVEZ CES INSTRUCTIONS POUR INSTALLER LE SUPPORT DE SÉCURITÉ ANTI-BASCULE FOURNI AVEC CE PRODUIT.

ATTENTION

Blessures graves ou fatales

peut provenir de meubles renversés. Pour éviter le basculement:

- * Installez la retenue de renversement fournie
- * placer les articles les plus lourds dans les tiroirs les plus bas
- * Sauf si spécifiquement conçu pour accommoder, ne pas placer les téléviseurs ou autres objets lourds sur le dessus de ce produit
- * Ne laissez jamais les enfants grimper ou pendre sur des tiroirs, des portes ou des étagères
- * N'ouvrez jamais plus d'un tiroir à la fois

L'utilisation de dispositifs de retenue peut uniquement réduire, mais non éliminer, le risque de basculement

OPTION 1: Fixation dans un montant mural (méthode préférée)

À l'aide d'un détecteur de goujons, localisez un goujon dans le mur. Placez votre appareil contre le mur, avec le support de sécurité aligné à cet endroit.

Pour faciliter la conduite de la vis, vous pouvez percer un trou pilote de 3 mm support dans le goujon.

Faites passer la vis à travers le support de sécurité dans le poteau mural. Serrer la vis qui n'était pas complètement serré.

OPTION 2: Fixation dans les cloisons sèches

Placez votre appareil là où vous le souhaitez contre un mur et marquez le mur à travers le support de sécurité, puis déplacez votre unité de côté.

Percez un trou de 5 mm de diamètre dans le panneau mural. Appuyez sur l'ancrage mural dans le trou jusqu'à ce qu'il affleure. Placez votre appareil en place et fixez le support mural à l'ancrage mural à l'aide de la vis.

Serrer la vis qui n'a pas été complètement serrée.

Page 27

MISE EN GARDE

MAXIMUM DE CHARGE

Cet appareil est conçu pour supporter la charge maximale enregistrée. Le dépassement de ces limites peut provoquer l'instabilité, l'effondrement et / ou causer des blessures graves.

Avertissement: Veuillez vous assurer que tous les objets sont retirés avant de déplacer l'unité assemblée. L'unité doit être soulevée par plus d'une personne, non traînée ou poussée. Ne pas le faire causer des dommages au produit, l'instabilité, l'effondrement du produit et / ou des blessures graves.

Page 28

Enregistrez votre produit pour recevoir les éléments suivants:

- * De nouveaux détails sur les tendances - Sneek vérifier la nouvelle
 - * Sondages - ont une voix dans notre communauté
 - * Offres exclusives et des codes de réduction
- Service de pièces de rechange rapide et facile

Pour enregistrer votre produit, visitez Ameriwoodhome.com

5 étoiles

Visitez le site Web de votre distributeur local, classez votre produit acheté et laissez des commentaires!

Nous aimerions étendre un grand "Merci" à tous nos clients pour prendre le temps de rassembler ce produit Ameriwood Home et de nous faire part de vos précieux commentaires

Merci!

Page 29

MERCI pour votre entreprise.

Vos commentaires et vos commentaires 5 étoiles sont importants pour nous!

Si vous êtes satisfait de ce produit, veuillez consulter le site sur lequel vous l'avez acheté.

Si votre produit a des problèmes, veuillez nous contacter afin que nous puissions les résoudre.

Veuillez noter que nous n'avons aucun contrôle sur la manière dont les transporteurs maritimes traitent nos produits et pourraient endommager votre commande Si votre produit est endommagé, veuillez nous contacter pour obtenir de l'aide.