

INSTALLATIONSANLEITUNG
INSTALLATION INSTRUCTION
INSTRUCTION D'INSTALLATION
ISTRUZIONI DI INSTALLAZIONE
INSTRUCCIONES DE INSTALACIÓN
N620P207712/N620P207714

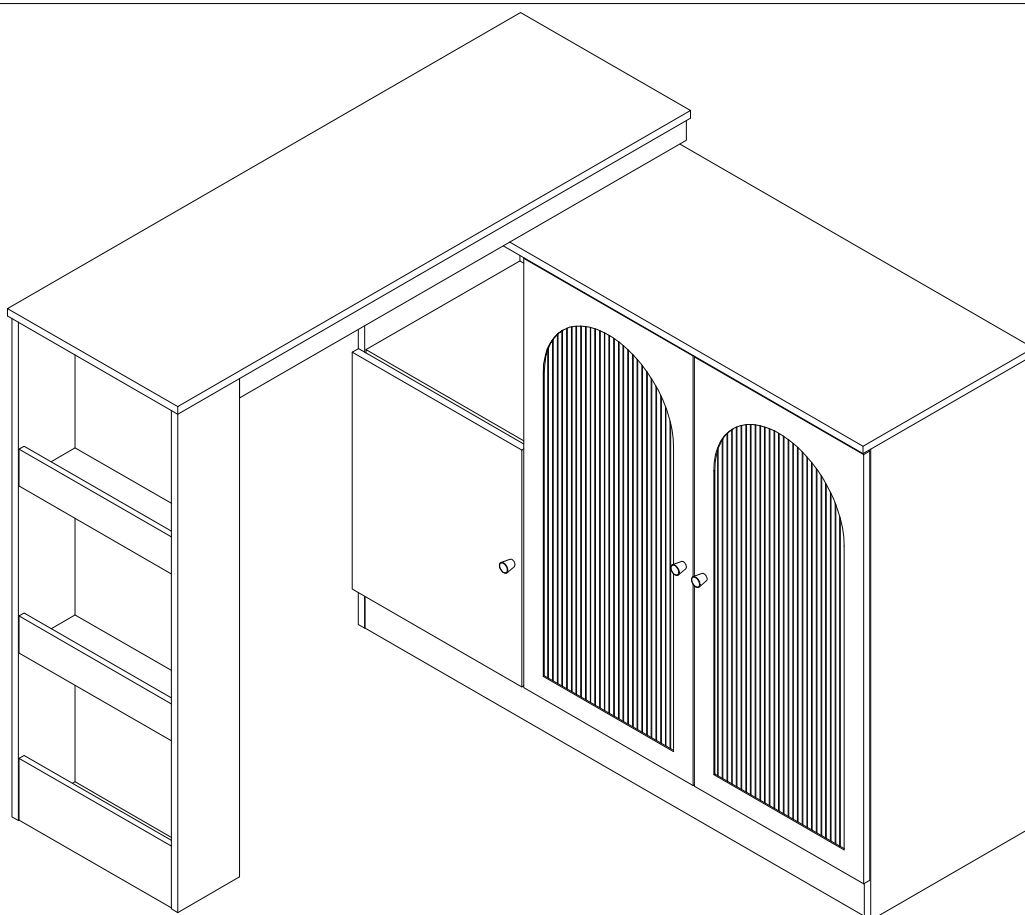

DE: Unser Produkt wird Ihnen in 2 Paketen geliefert. Die Lieferzeiten dieser 2 Pakete können abweichen, bitte haben Sie etwas Geduld und vielen Dank für Ihr Verständnis.

UK: Our product will be delivered to you in 2 packages. The delivery times of these 2 packages may differ, please be patient and thank you for your understanding.

FR: Notre produit vous sera livré en 2 colis. Les délais de livraison de ces 2 colis peuvent différer, soyez patient et merci pour votre compréhension.

IT: Il nostro prodotto verrà consegnato in 2 pacchi. I tempi di consegna di questi 2 pacchi possono variare; vi preghiamo di avere un po' di pazienza e vi ringraziamo per la vostra comprensione.

ES: Nuestro producto se entregará en 2 paquetes. Los tiempos de entrega de estos 2 paquetes pueden variar; por favor, tenga un poco de paciencia y gracias por su comprensión.

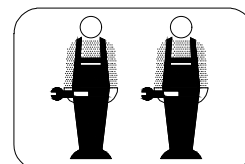

DE

Warnung

- 1 Die maximale Tragfähigkeit des Produkts beträgt 60 kg. Überladen vermeiden.
- 2 Kinder dürfen nicht auf Möbel klettern, da dies zu Kippen und schweren Verletzungen führen kann.
- 3 Um die Sicherheit zu gewährleisten, installieren Sie bitte gemäß den Anweisungen korrekt und holen Sie bei Bedarf professionelle Hilfe ein.
- 4 Stellen Sie Möbel nicht in der Nähe von Wärmequellen oder heißen Gegenständen auf, um Brandgefahr zu vermeiden.
- 5 Vermeiden Sie es, Möbel in feuchten Umgebungen zu platzieren, um Materialschäden zu vermeiden.
- 6 Überprüfen Sie regelmäßig alle Verbindungsstücke und Befestigungen, um sicherzustellen, dass sie fest sitzen und unerwartete Unfälle zu verhindern.
- 7 Reinigen Sie Möbel mit einem feuchten Tuch oder Alkohol, vermeiden Sie die Verwendung von Reinigungsmitteln, die ätzende Chemikalien enthalten.

UK

Warning

- 1 The maximum load capacity of the product is 60kg. Do not overload.
- 2 Children should not climb on furniture, as this may cause tipping and serious injuries.
- 3 To ensure safety, please install according to the instructions correctly, and seek professional assistance if necessary.
- 4 Do not place furniture near heat sources or hot items to avoid the risk of fire.
- 5 Do not place furniture in damp environments to prevent material damage.
- 6 Regularly check all connections and fasteners to ensure they are secure to prevent accidents.
- 7 Clean furniture with a damp cloth or alcohol, avoid using cleaning agents containing corrosive chemicals.

FR

Avertissement

- 1 La charge maximale du produit est de 60 kg. Ne pas surcharger.
- 2 Les enfants ne doivent pas grimper sur les meubles, car cela peut entraîner un renversement et des blessures graves.
- 3 Pour assurer la sécurité, veuillez installer correctement selon les instructions et demander une assistance professionnelle si nécessaire.
- 4 Ne placez pas les meubles près de sources de chaleur ou d'objets chauds pour éviter les risques d'incendie.
- 5 Évitez de placer les meubles dans des environnements humides pour éviter les dommages aux matériaux.
- 6 Vérifiez régulièrement toutes les connexions et les fixations pour vous assurer qu'elles sont sécurisées et prévenir les accidents.
- 7 Nettoyez les meubles avec un chiffon humide ou de l'alcool, évitez d'utiliser des agents de nettoyage contenant des produits chimiques corrosifs.

IT

Avviso

- 1 La capacità massima del prodotto è di 60 kg. Non sovraccaricare.
- 2 I bambini non devono arrampicarsi sui mobili, poiché ciò potrebbe causare il ribaltamento e gravi lesioni.
- 3 Per garantire la sicurezza, installare correttamente secondo le istruzioni e chiedere assistenza professionale se necessario.
- 4 Non posizionare i mobili vicino a fonti di calore o oggetti caldi per evitare il rischio di incendio.
- 5 Evitare di posizionare i mobili in ambienti umidi per evitare danni ai materiali.
- 6 Controllare regolarmente tutte le connessioni e i fissaggi per assicurarsi che siano sicuri e prevenire gli incidenti.
- 7 Pulire i mobili con un panno umido o alcool, evitare l'uso di agenti di pulizia contenenti sostanze chimiche corrosive.

ES

Aviso

- 1 La capacidad máxima de carga del producto es de 60 kg. No sobrecargar.
- 2 Los niños no deben trepar sobre los muebles, ya que esto puede causar que se vuelquen y provocar lesiones graves.
- 3 Para garantizar la seguridad, instale correctamente según las instrucciones y busque asistencia profesional si es necesario.
- 4 No coloque los muebles cerca de fuentes de calor o objetos calientes para evitar el riesgo de incendio.
- 5 Evite colocar los muebles en entornos húmedos para evitar daños en los materiales.
- 6 Revise regularmente todas las conexiones y sujeciones para asegurarse de que estén seguras y prevenir accidentes.
- 7 Limpie los muebles con un paño húmedo o alcohol, evite el uso de agentes de limpieza que contengan productos químicos corrosivos.

Importeur	Decobus Handel GmbH
Adresse	InnungsstraBe 9, 21244 Buchholz, Deutschland
URL	https://www.decobusgroup.de
Hersteller	FUJIAN FARSEE IMPORT & EXPORT CO., LTD
Adresse	22/F., WORLD TRADEPLAZA, 71 WUSI ROAD, GULOU DISTRICT, FUZHOU, FUJIAN, CHINA.
Email/URL	15980248168@163.COM

DE: Vor dem Einbau die Schrauben in die Löcher stecken und festziehen, aber nicht bis 100%, 70% bis 80% anziehen reicht aus. Schließlich, nachdem alle Schrauben installiert sind, ziehen Sie alle Schrauben auf 100%.

Wenn Sie auf diese Probleme stoßen, wie z. B. Fehlausrichtung der Löcher oder Unfähigkeit, bestimmte Teile zu installieren, überprüfen Sie bitte, ob die Schrauben korrekt verwendet werden und passen Sie die Dichtigkeit der Schrauben an.

UK: Before installation, insert the screws into the holes and tighten them, but do not tighten them to 100%, 70% to 80% is sufficient. Finally, after all screws are installed, tighten all screws to 100%. If you encounter these issues, such as if the holes cannot be aligned or some parts cannot be installed, please check if the screws are used correctly and adjust the tightness of the screws.

FR: Insérer la vis dans le trou avant la fin de l'assemblage, serrer la vis, mais ne pas serrer à 100%, 70% ~ 80% est correct. Enfin, une fois que toutes les vis sont bien serrées, toutes les vis sont serrées à 100%. Si vous rencontrez ces problèmes, par exemple si les trous ne sont pas alignés ou si certaines pièces ne peuvent pas être montées, vérifiez que les vis sont utilisées correctement et Ajustez leur serrage.

IT: Prima dell'installazione, inserire le viti nei fori e stringerle, ma non al 100%, è sufficiente stringerle al 70% - 80%. Infine, dopo aver installato tutte le viti, stringere tutte le viti al 100%. Se riscontri problemi come disallineamenti dei fori o difficoltà nell'installare alcuni componenti, verifica che le viti siano utilizzate correttamente e regola la tensione delle viti.

ES: Antes de la instalación, coloque los tornillos en los agujeros y apriételos, pero no al 100%; apretar al 70% - 80% es suficiente. Finalmente, después de haber instalado todos los tornillos, apriete todos los tornillos al 100%. Si se encuentra con problemas como desalineación de los agujeros o dificultad para instalar ciertas piezas, verifique que los tornillos se estén utilizando correctamente y ajuste la tensión de los tornillos.

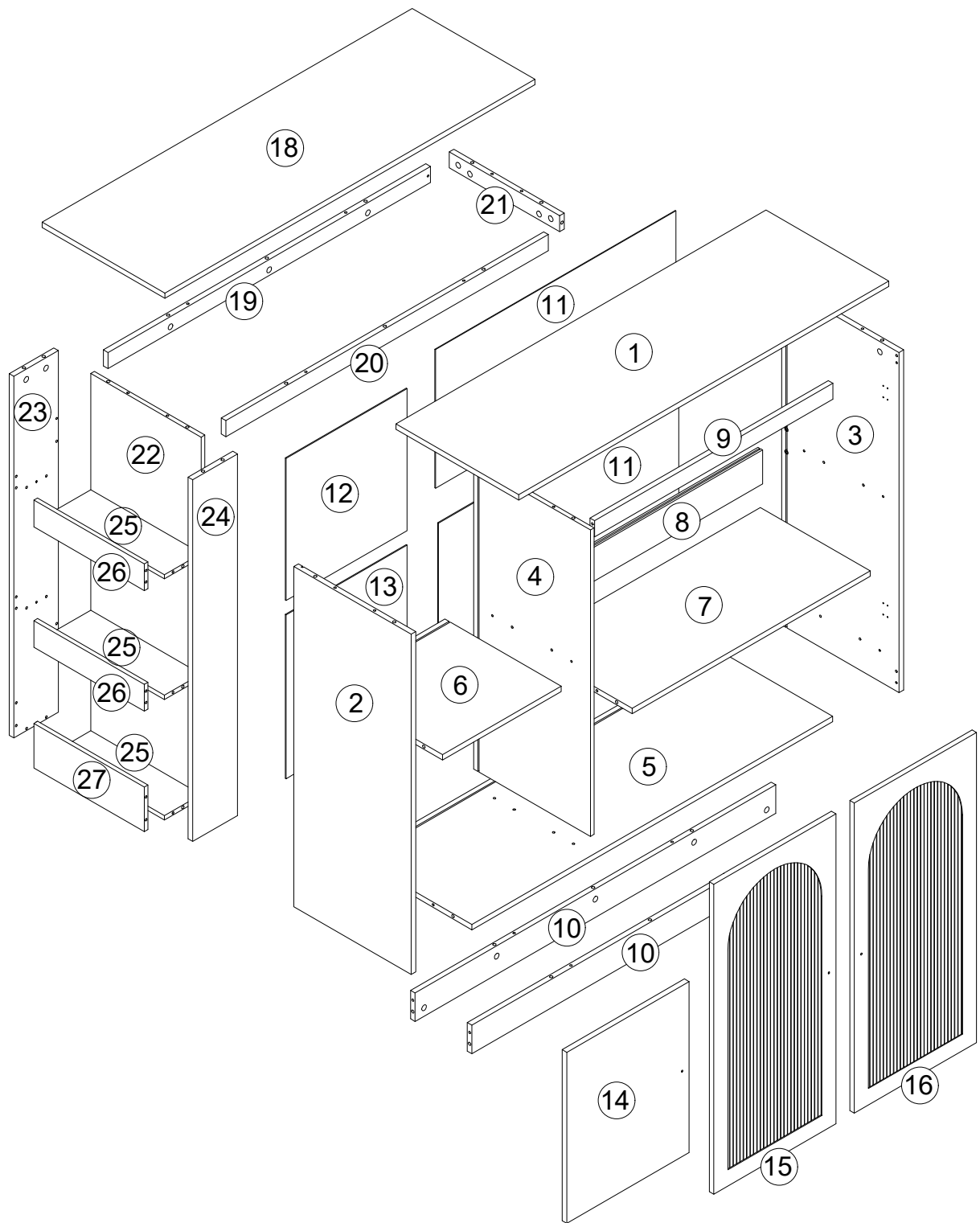



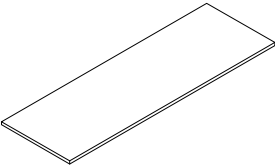
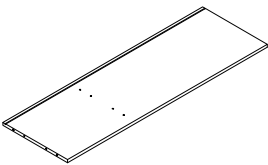
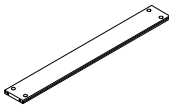
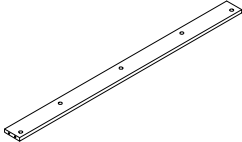
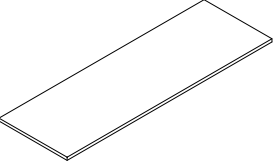
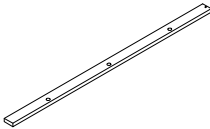
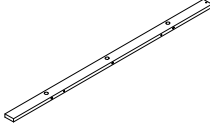
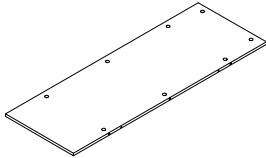
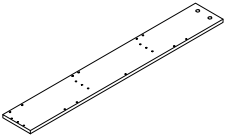
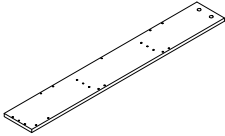
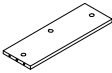



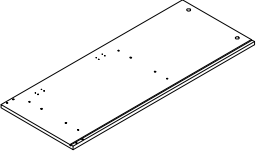
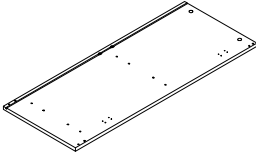
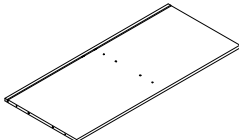
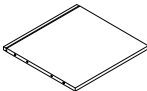
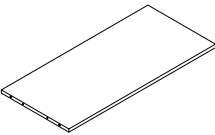
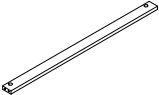
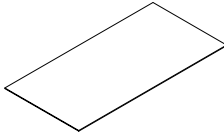
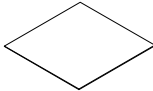
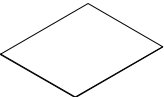
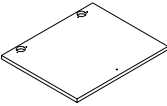
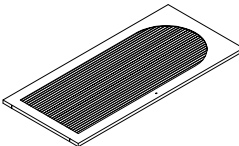
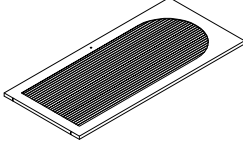
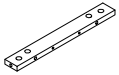
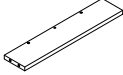
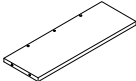



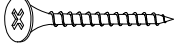

N620P207712

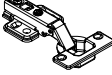

			
① x 1pc	⑤ x 1pc	⑧ x 1pc	⑩ x 2pcs
			
⑱ x 1pc	⑲ x 1pc	⑳ x 1pc	㉒ x 1pc
			
㉓ x 1pc	㉔ x 1pc	㉕ x 3pcs	

N620P207714

			
② x 1pc	③ x 1pc	④ x 1pc	⑥ x 1pc
			
⑦ x 1pc	⑨ x 1pc	⑪ x 2pcs	⑫ x 1pc
			
⑬ x 1pc	⑭ x 1pc	⑮ x 1pc	⑯ x 1pc
			
㉑ x 1pc	㉒ x 2pcs	㉓ x 1pc	

Hardware List Hardwareliste

 Ø6*35mm Ⓐ x 65pcs	 Ø15*9mm Ⓑ x 65pcs	 4*40mm Ⓒ x 2pcs	 6*30mm Ⓓ x 70pcs	 4*18mm Ⓔ x 3pcs
 Ⓕ x 3pcs	 3.5*12mm Ⓖ x 36pcs	 Ø35mm Ⓗ x 6pcs	 3*14mm Ⓘ x 16pcs	 Ⓙ x 16pcs
 30*15mm Ⓚ x 12pcs	 Ø20mm Ⓛ x 10pcs	 Ø15mm Ⓜ x 2pcs		

 3.5*12mm Ⓖ x 36pcs	 3*14mm Ⓘ x 16pcs
--	--

DE:Bitte beachten Sie, dass die Formen der Schrauben G und I ähnlich sind. Bitte installieren Sie entsprechend der Anleitung und unterscheiden Sie sie!

UK>Please note that the shapes of screws G and I are similar. Please install according to the instructions and distinguish them!

FR:Notez que les vis G et I ont des formes similaires. Veuillez les installer en suivant les instructions pour les séparer!

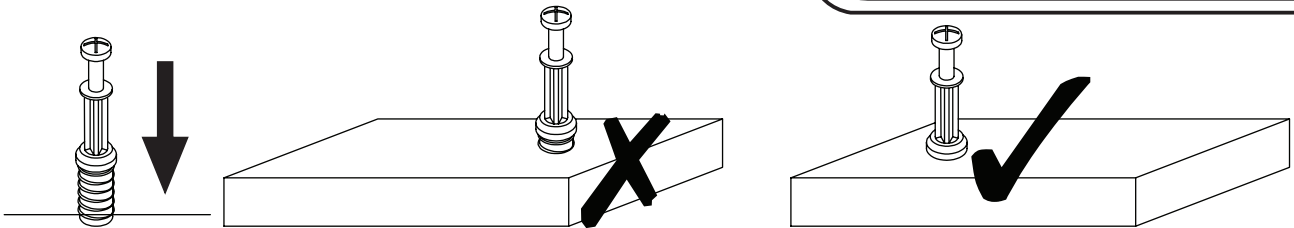

EN_QUICKFIT: Tighten quickfit until shoulder is flush with panel. Do not overtighten or undertighten.

FR_RACCORD RAPIDE: Faites serrer le raccord rapide jusqu'à ce que l'épaulement soit parfaitement encastré dans le panneau. Il ne faut ni trop serrer ni insuffisamment serrer.

ES_QUICKFIT: Apriete quickfit hasta que el hombro se descargue con el panel. NO lo sobreapriete ni lo apriete poco.

DE_QUICKFIT: Ziehen Sie den Quickfit fest, bis die Schulter mit der Platte bündig ist. Bitte nicht zu fest oder zu schwach anziehen.

IT_MONTAGGIO RAPIDO: Stringere il montaggio rapido fino a quando la spalla è a filo con il pannello, non stringere troppo o troppo poco.

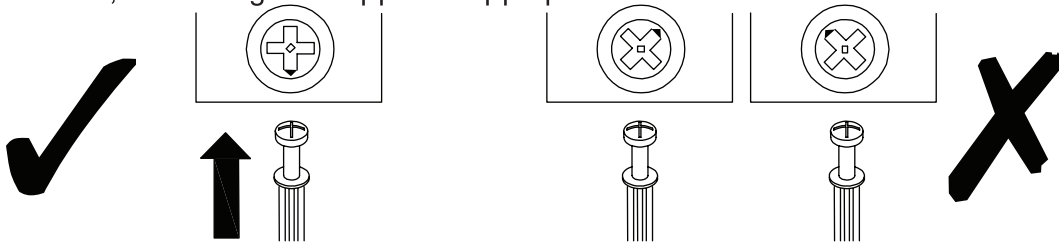

EN_CAM LOCK: When fitting cam lock, ensure starting position is correct before you insert connecting quickfit.

FR_SERRURE BATTEUSE: Avant d'insérer la serrure batteuse, veillez à la bonne orientation avant d'insérer le raccord rapide.

ES_CIERRE DE LA CÁMARA: Cuando instale el cierre de la cámara, asegúrese de que la posición de inicio es correcta antes de que inserte el quickfit conector.

DE_CAM-LOCK: Achten Sie bei der Montage des Cam-Locks auf die richtige Ausgangsposition, bevor Sie den Quickfit einsetzen.

IT_BLOCCAGGIO A CAMMA: Quando si monta il bloccaggio a camma, assicurarsi che la posizione iniziale sia corretta prima di inserire il montaggio rapido di collegamento.

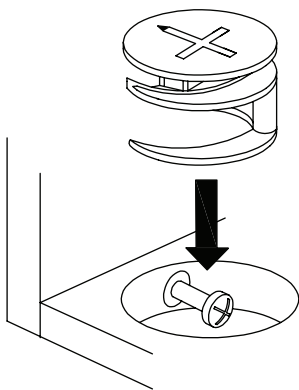

EN_Quickfit head should be in the centre of the cam lock when the two panels are joined.

Cam lock should be inserted before quickfit.

FR_Lorsque les deux panneaux sont assemblés, la tête du raccord rapide doit reposer au centre de la serrure batteuse. Il faut insérer la serrure batteuse avant le raccord rapide.

ES_El cabezal del quickfit debe estar en el centro del cierre de la cámara cuando se unan los dos paneles.

Se debe insertar el cierre de la cámara antes que el quickfit.

DE_Der Quickfit-Kopf sollte sich in der Mitte des Cam-Locks befinden, wenn die beiden Platten zusammengefügt sind. Der Cam-Lock sollte vor dem Quickfit eingesetzt werden.

IT_La testa del montaggio rapido deve trovarsi al centro del bloccaggio a camma quando i due pannelli sono uniti.

Il Bloccaggio a Camma deve essere inserito prima del montaggio rapido.

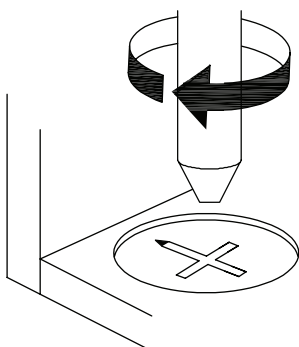

EN_Turn cam lock clockwise to tighten.



FR_Faites tourner la serrure batteuse dans le sens des aiguilles d'une montre pour la resserrer.

ES_Gire el cierre de la cámara en sentido horario para apretarlo.

DE_Drehen Sie den Cam-Lock im Uhrzeigersinn, um ihn festzuziehen.

IT_Ruotare il bloccaggio a camma in senso orario per stringere.

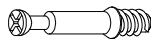
Step 1
Schritt 1

	
Ø6*35mm	6*30mm
(A) x 13pcs	(D) x 4pcs

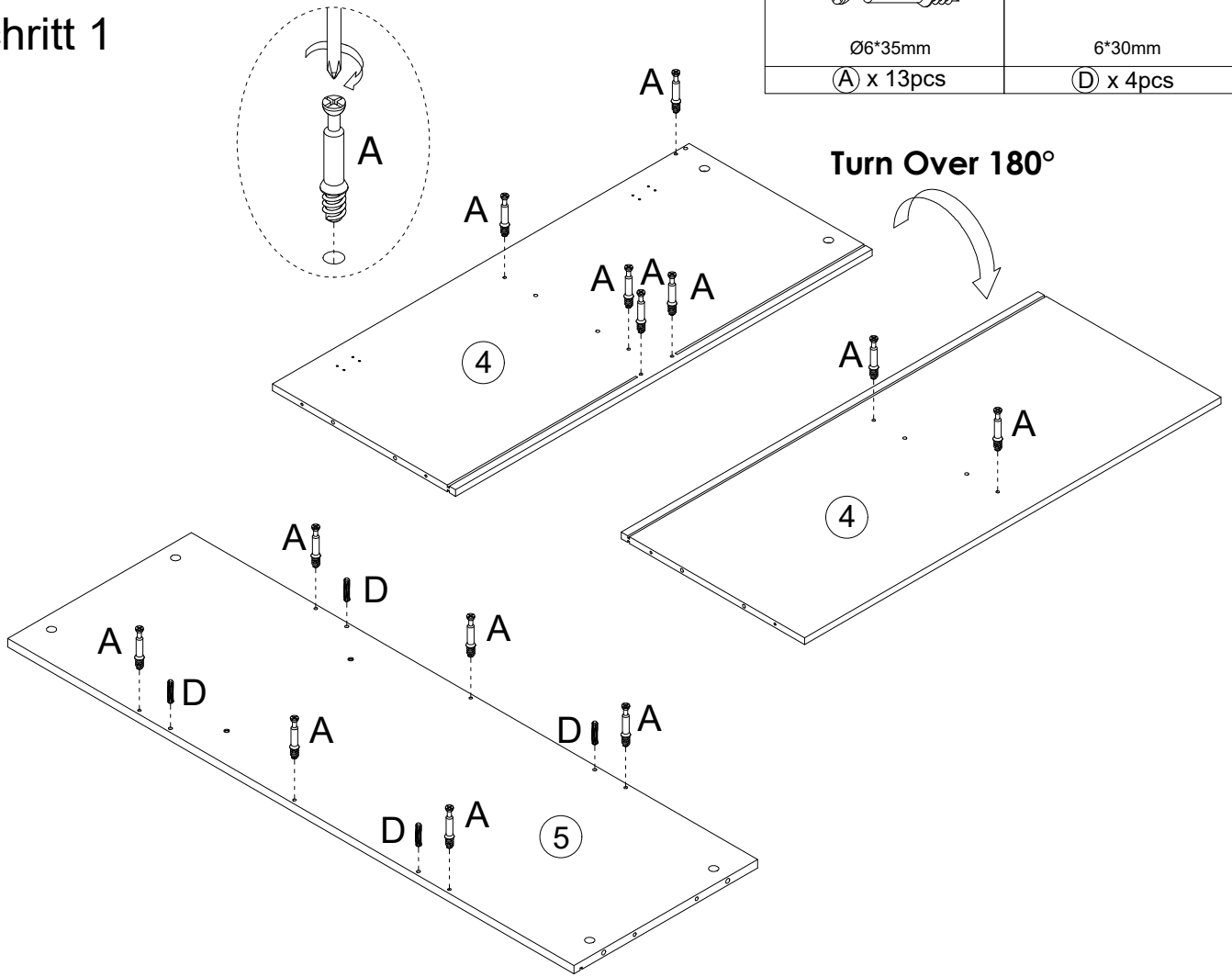

Step 2
Schritt 2

Ø15*9mm
(B) x 6pcs

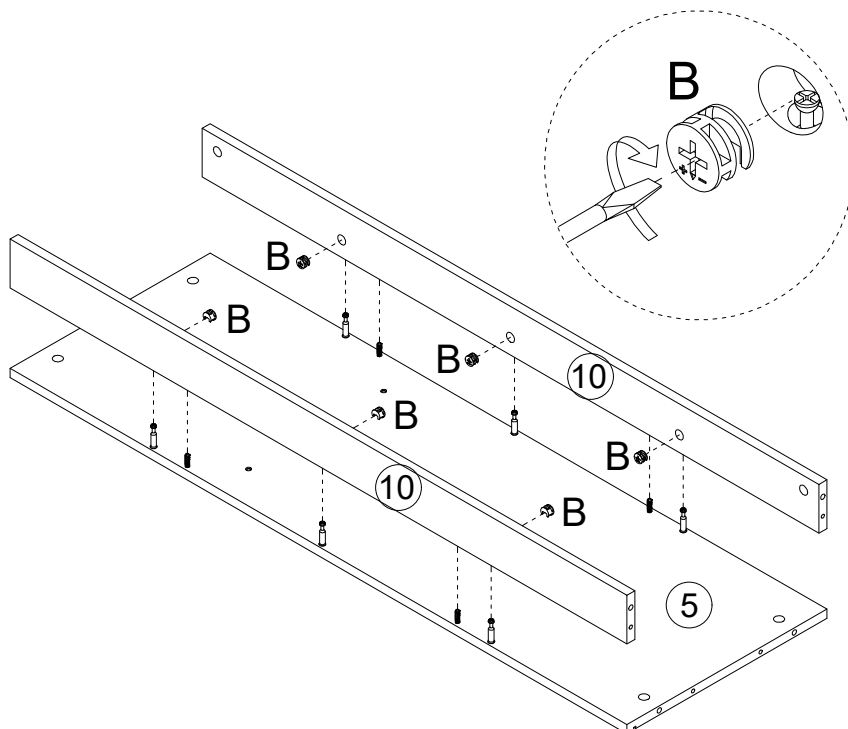

Step 3
Schritt 3



Ø15*9mm

(B) x 2pcs



6*30mm

(D) x 4pcs

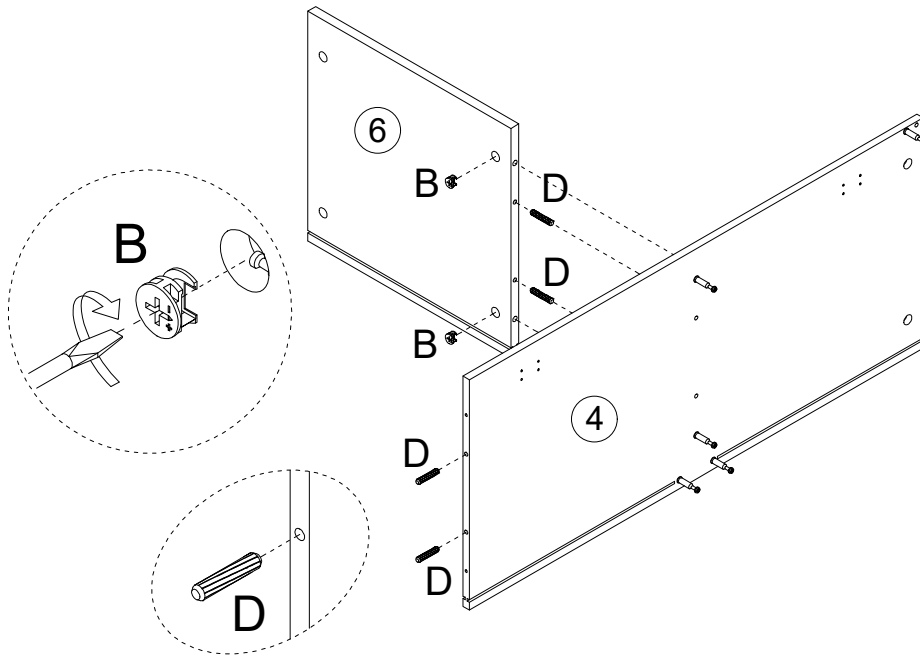

Step 4
Schritt 4

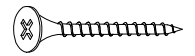

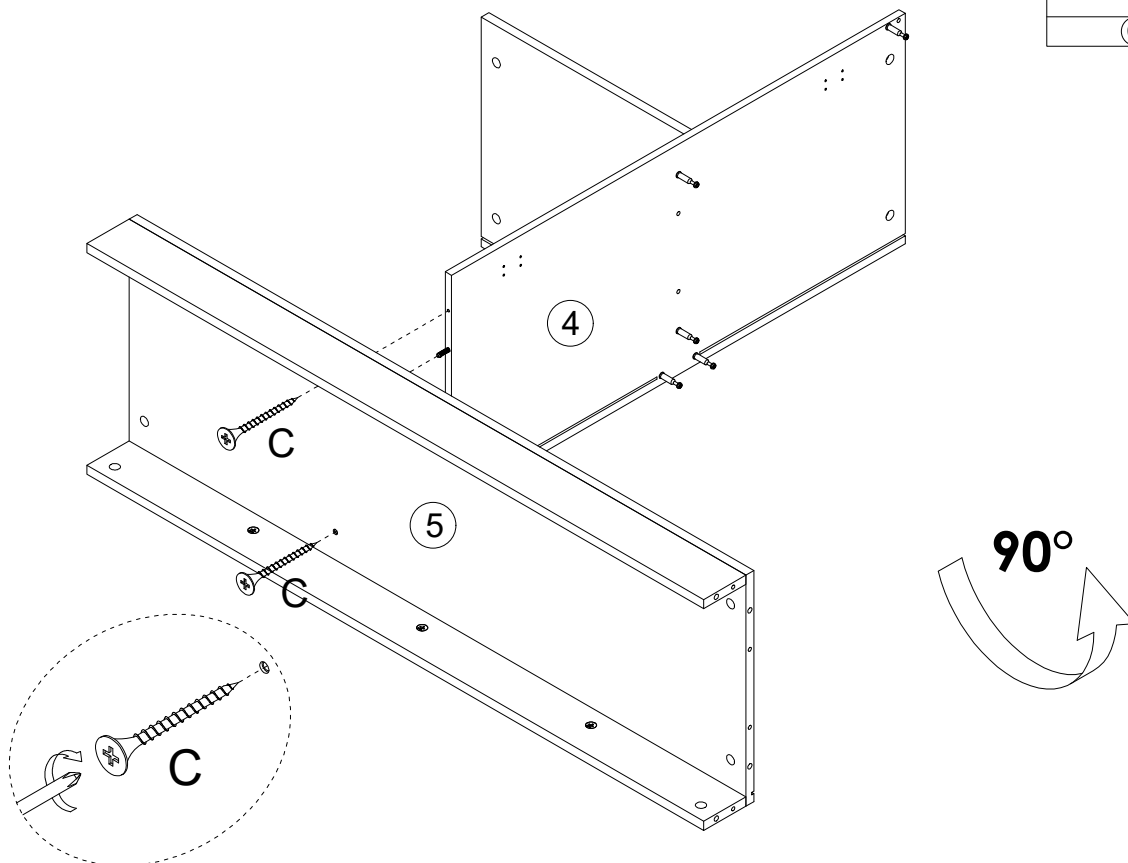

4*40mm

(C) x 2pcs



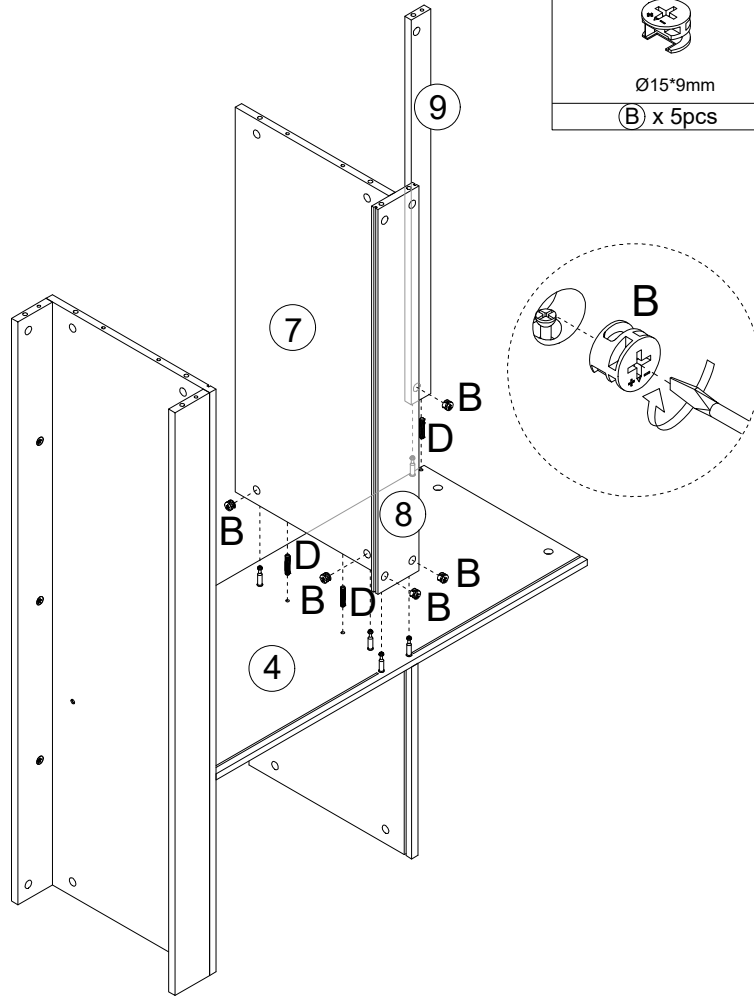

Step 5
Schritt 5

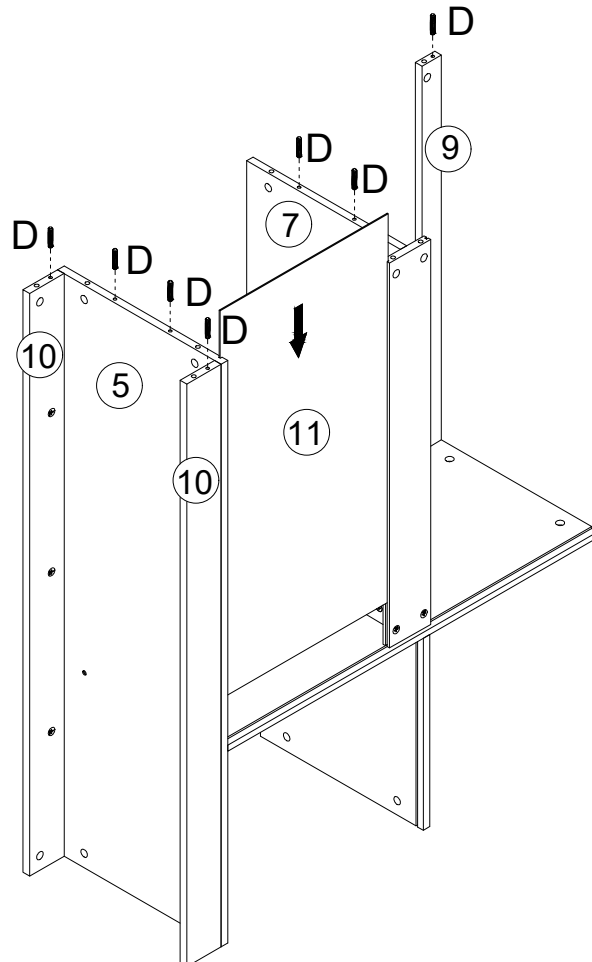
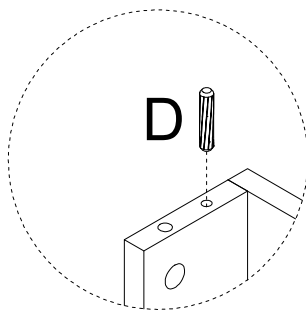

	
Ø15*9mm	6*30mm
(B) x 5pcs	(D) x 3pcs

Step 6
Schritt 6



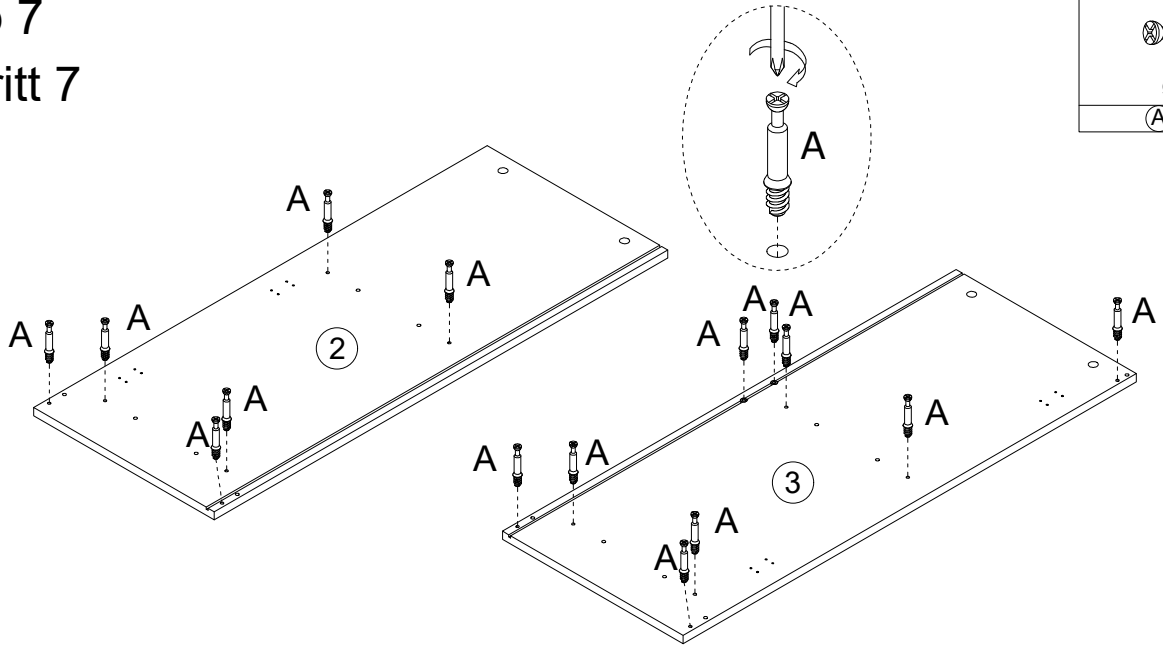

6*30mm
(D) x 7pcs

Step 7
Schritt 7

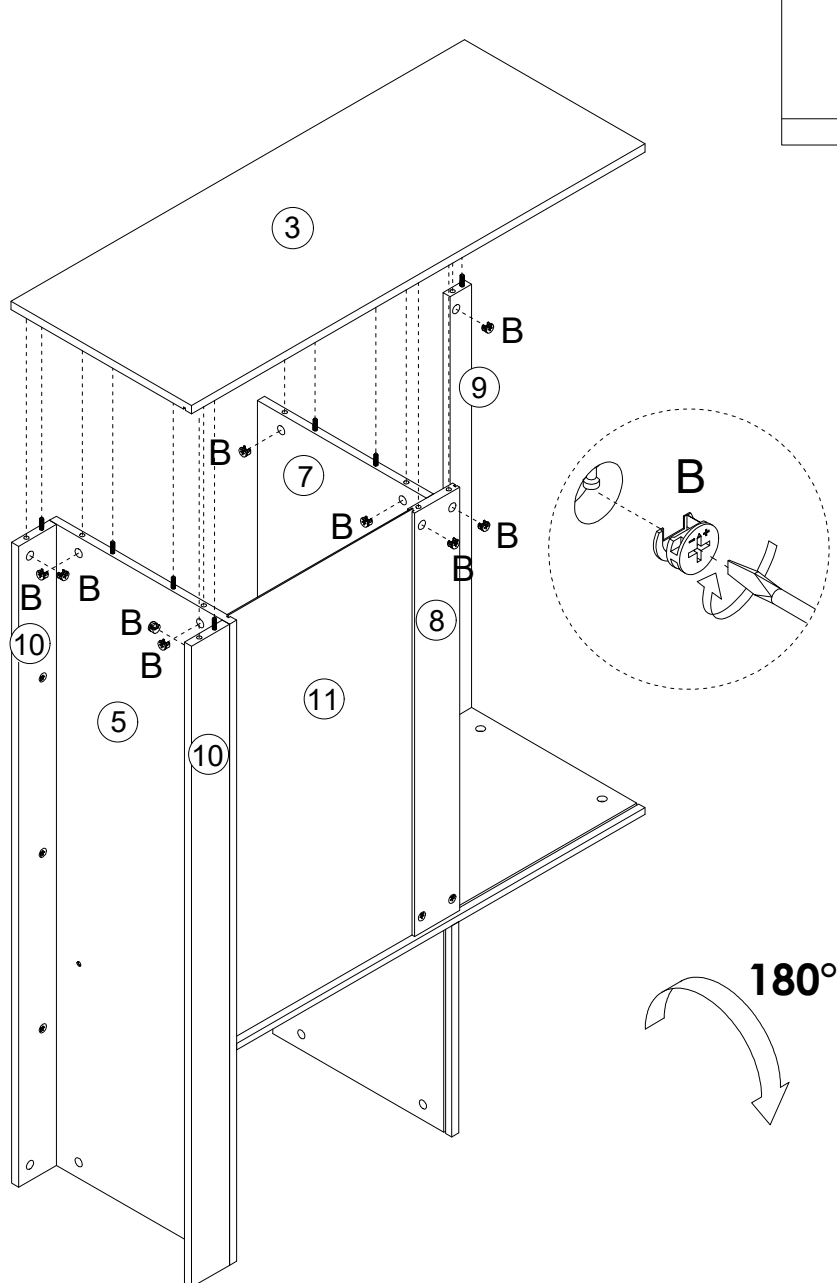

Step 8
Schritt 8



Step 9
Schritt 9

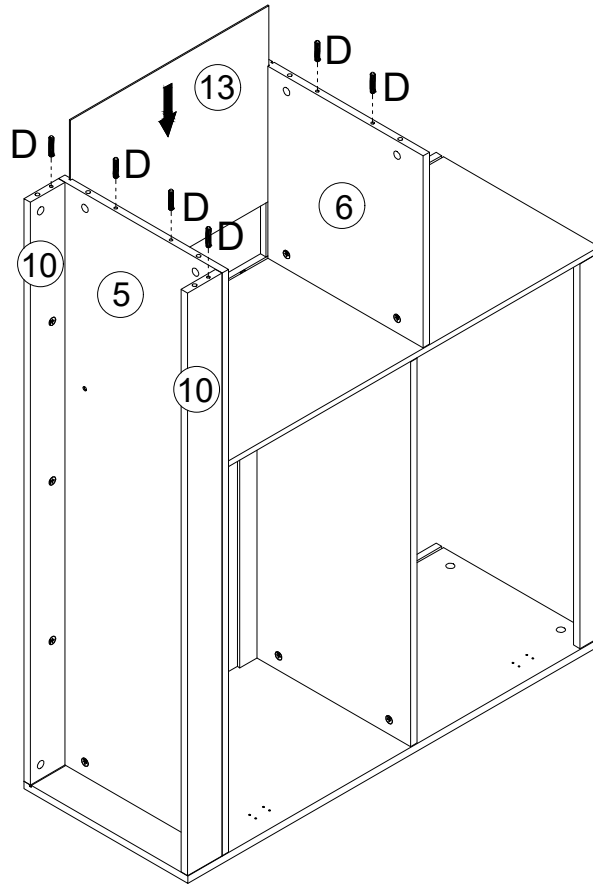
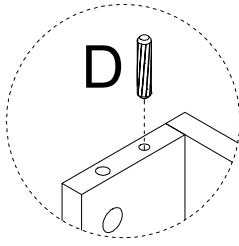

6*30mm

(D) x 6pcs

Step 10
Schritt 10



Ø15*9mm

(B) x 6pcs

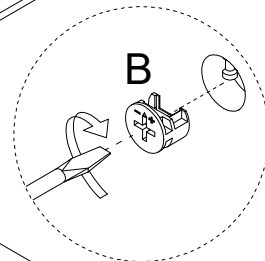
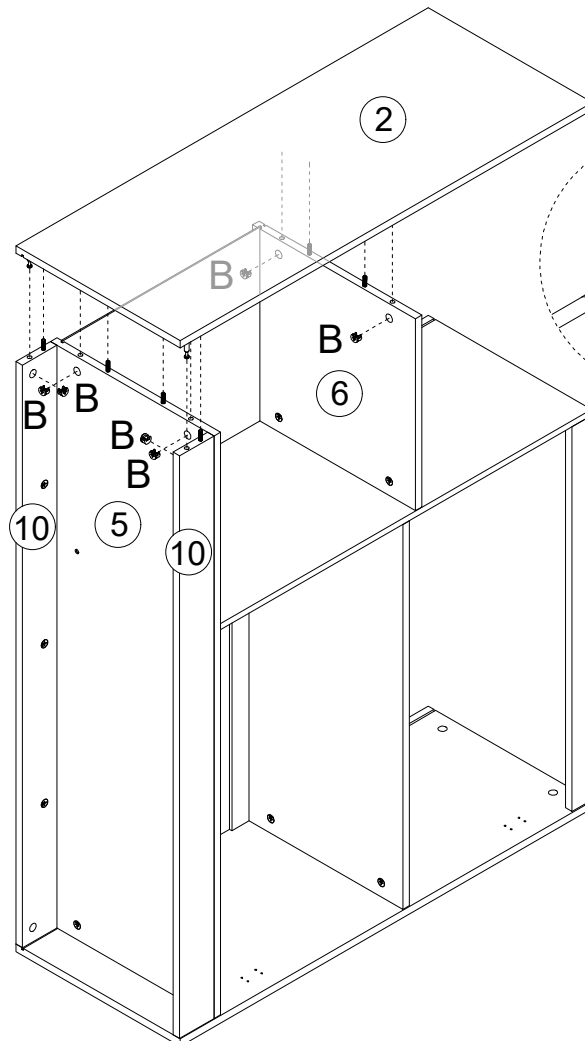

Step 11
Schritt 11



30*15mm

(K) x 8pcs

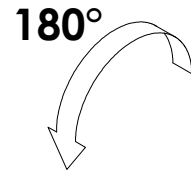
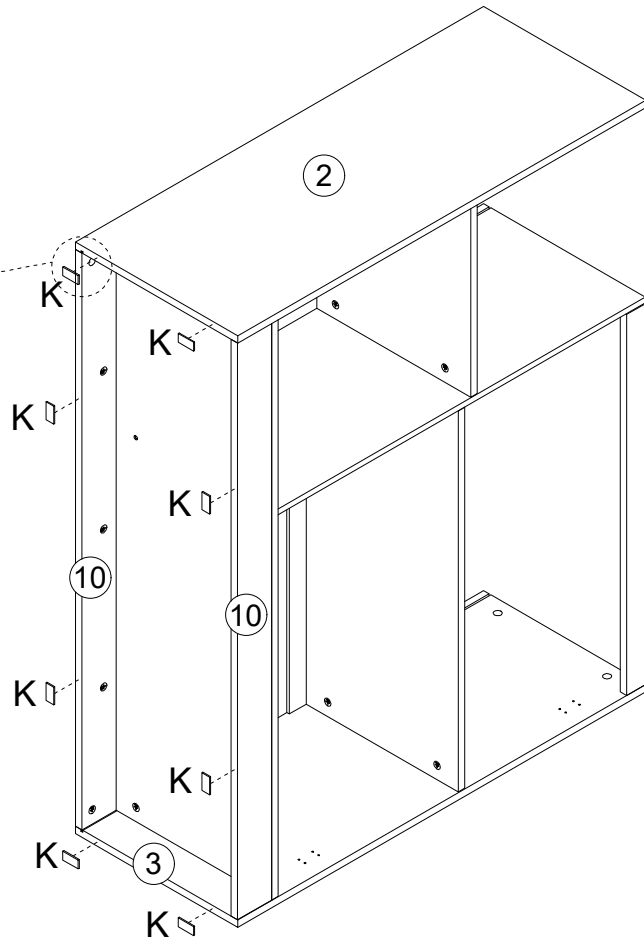
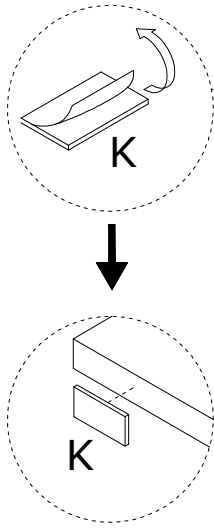

Step 12
Schritt 12



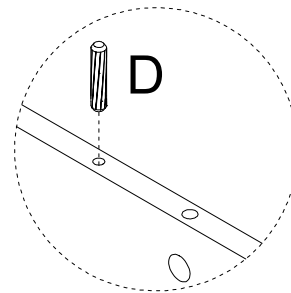
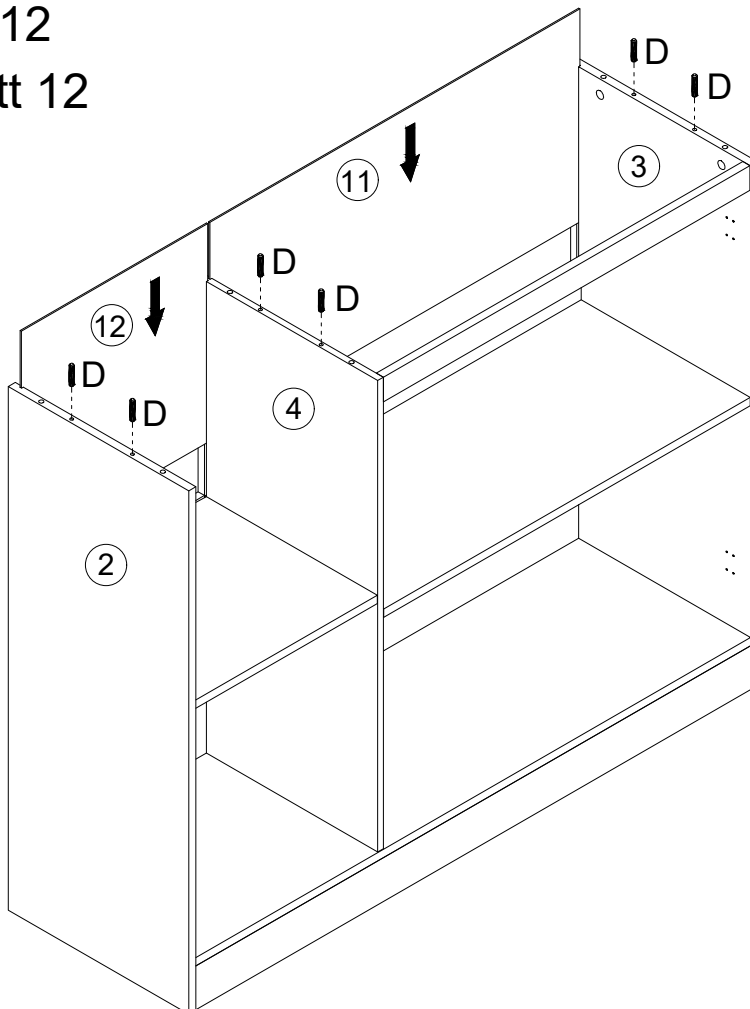

6*30mm

(D) x 6pcs



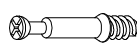

Step 13 Schritt 13

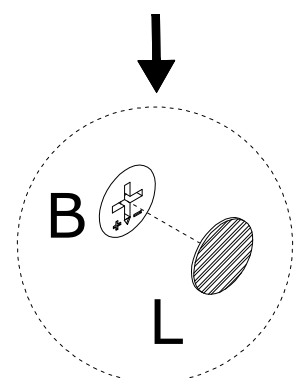
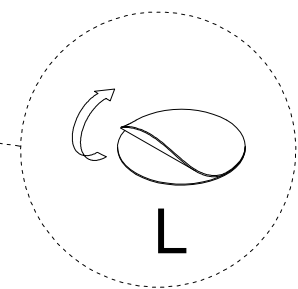
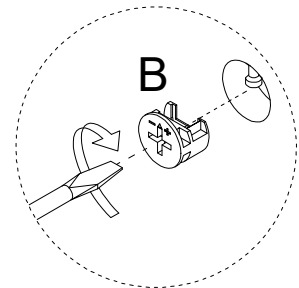
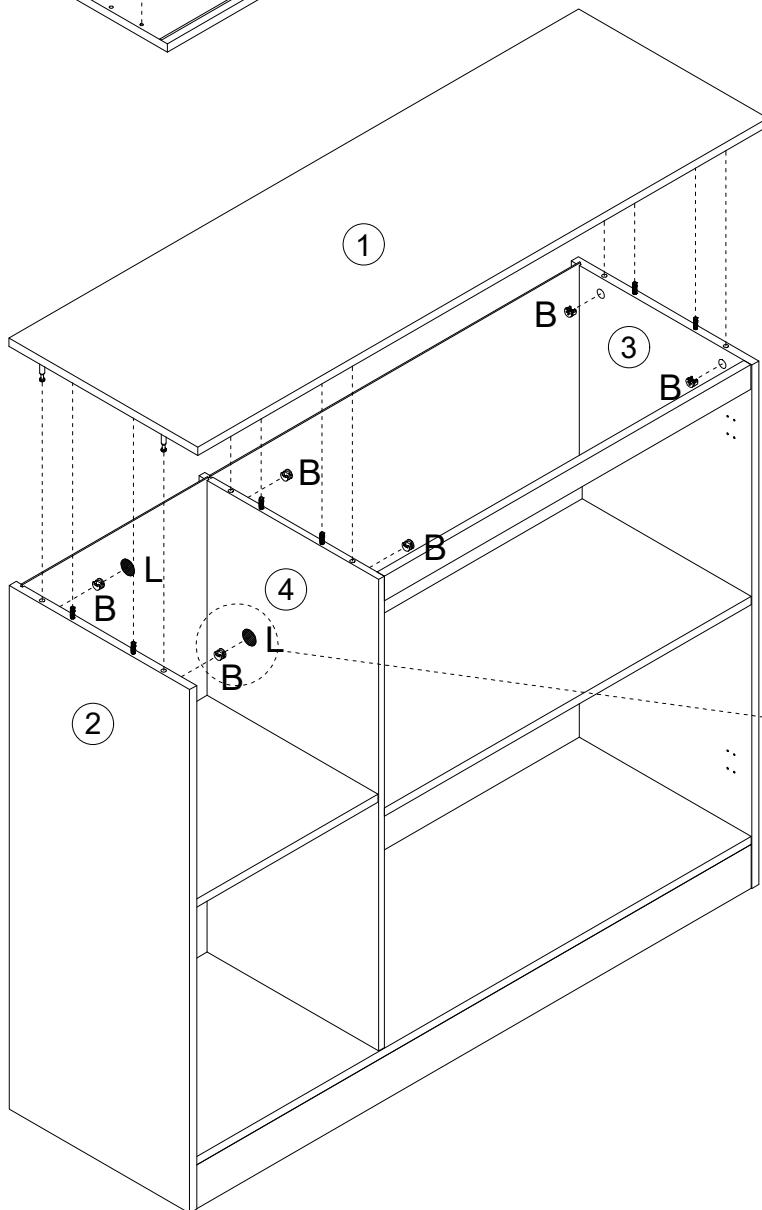
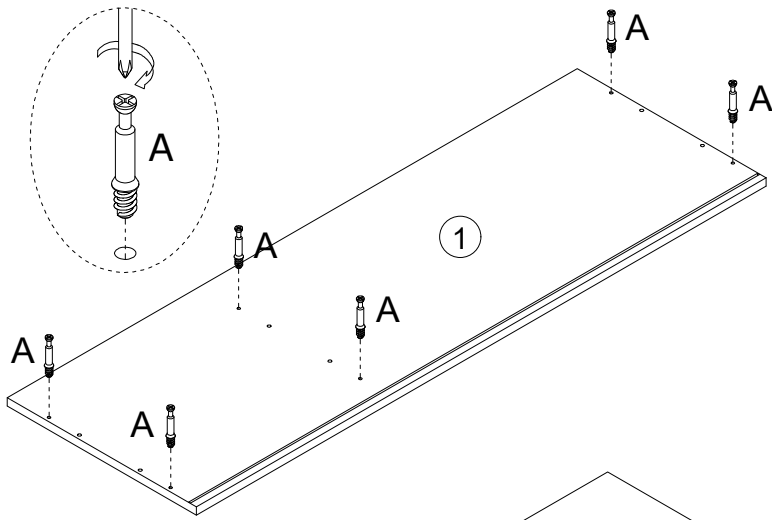
		
Ø6*35mm	Ø15*9mm	Ø20mm
(A) x 6pcs	(B) x 6pcs	(L) x 2pcs

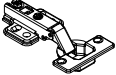

Step 14 Schritt 14

			
4*18mm		3.5*12mm	Ø35mm
E x 3pcs	F x 3pcs	G x 12pcs	H x 6pcs

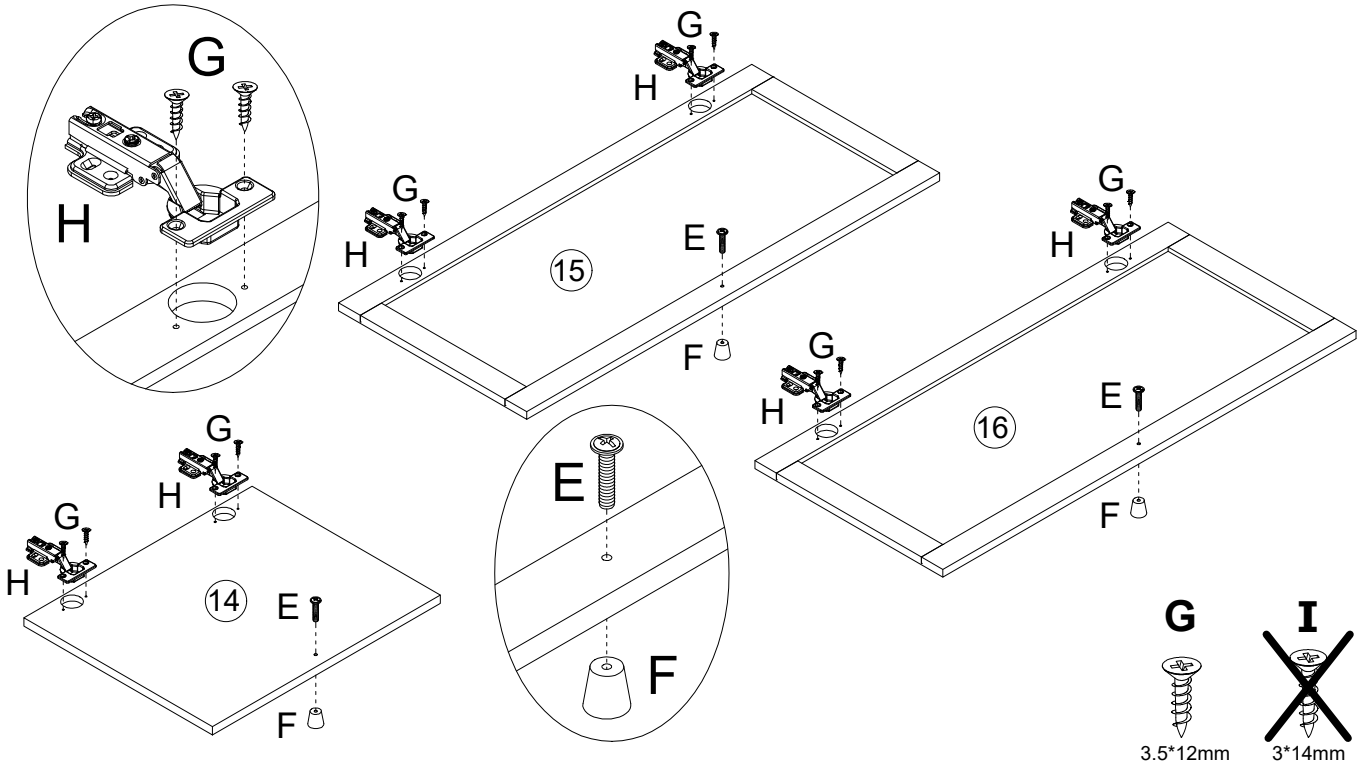



Step 15 Schritt 15

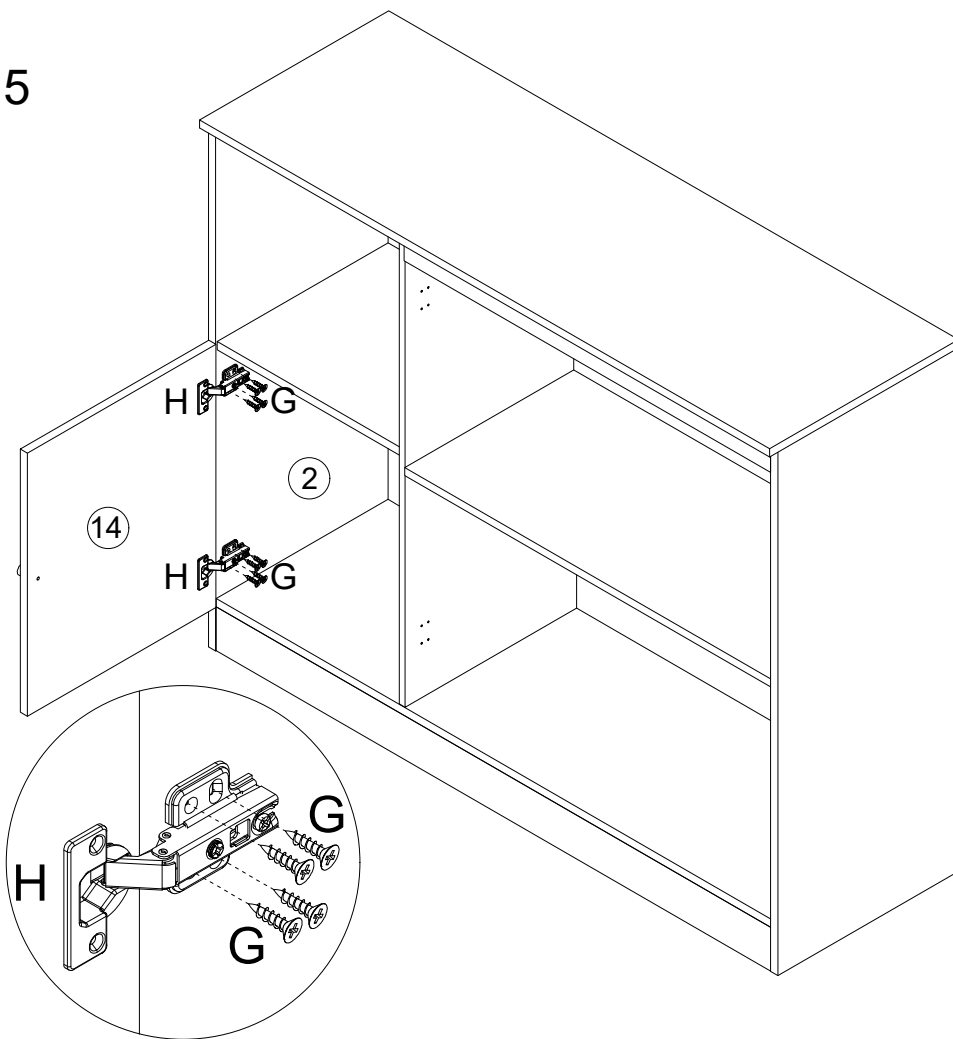

3.5*12mm
G x 8pcs

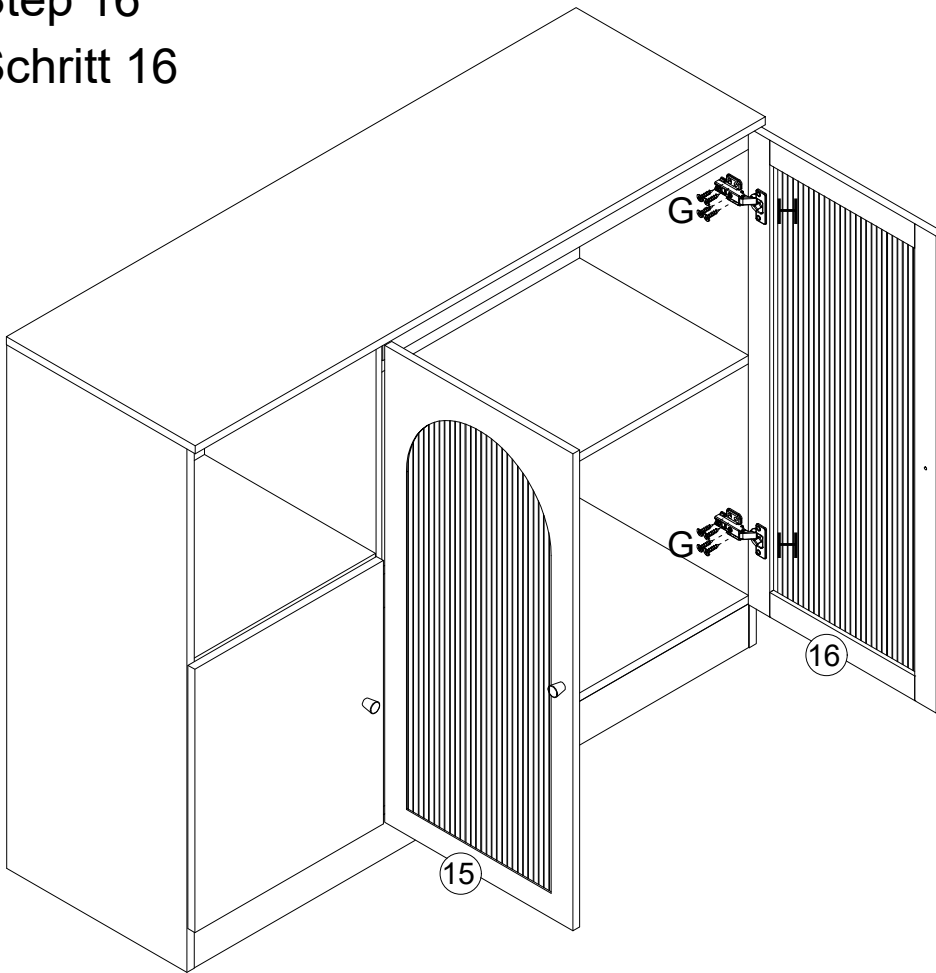

Step 16
Schritt 16



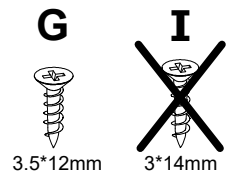
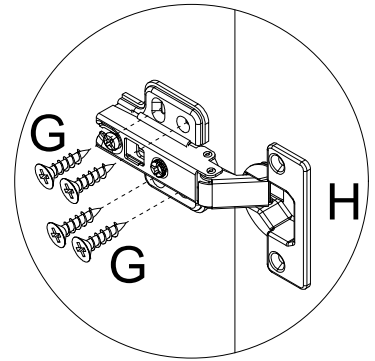

3.5*12mm
ⓐ x 16pcs



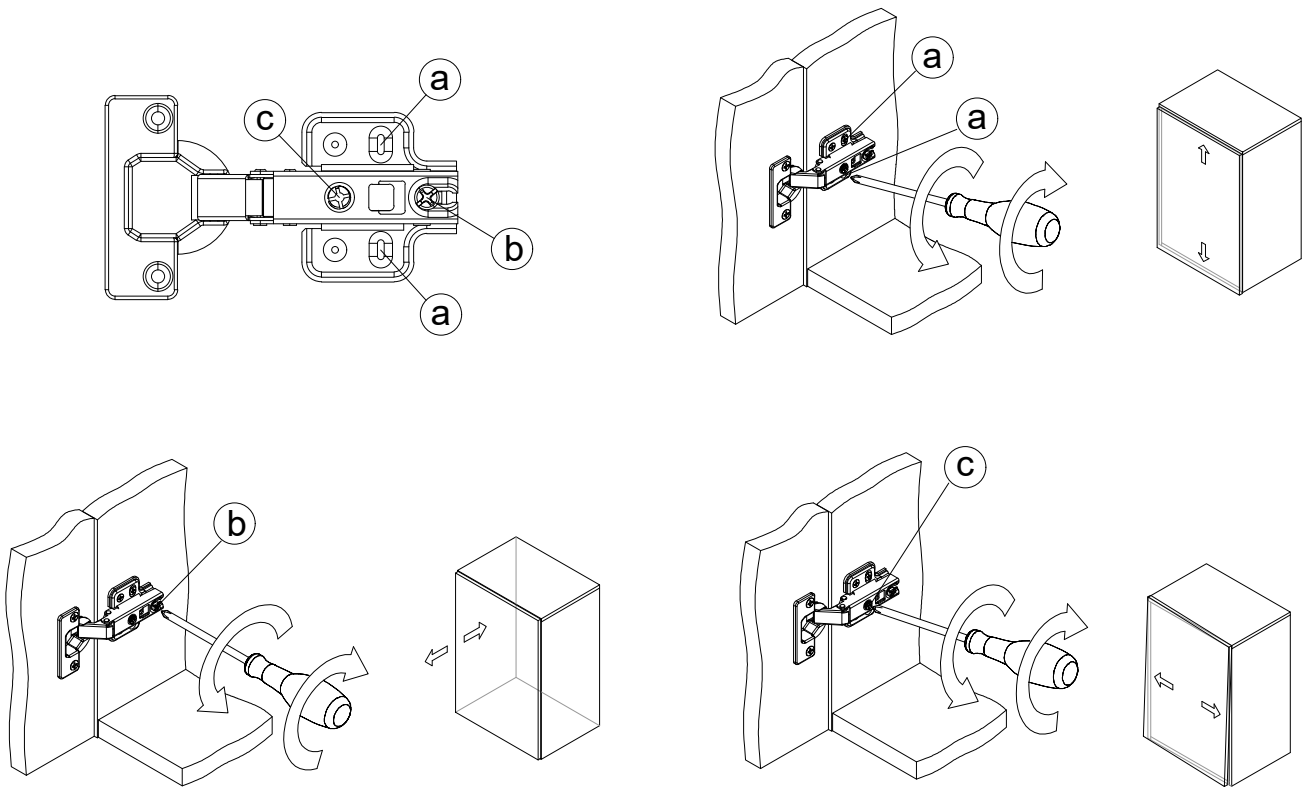

Step 17
Schritt 17

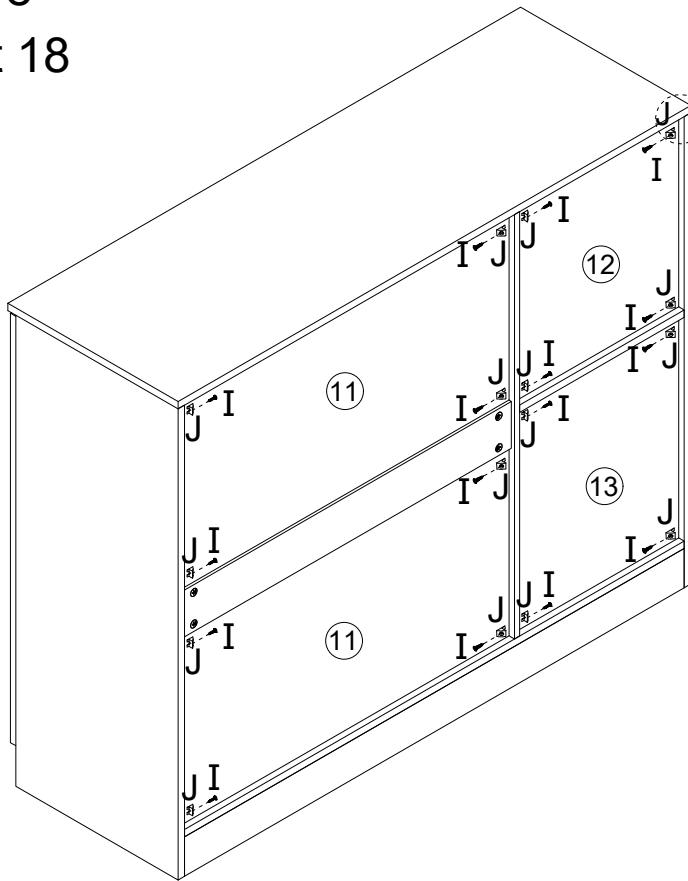



Step 18 Schritt 18

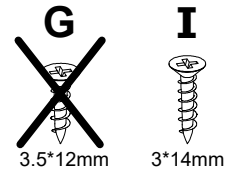
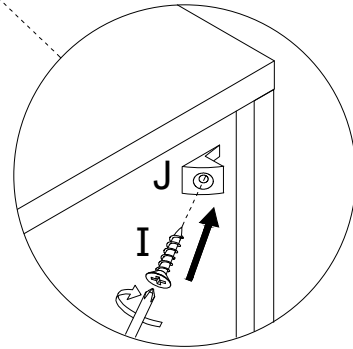

	
3*14mm	
(I) x 16pcs	(J) x 16pcs

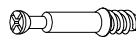

Step 19 Schritt 19

		
Ø6*35mm	Ø15*9mm	6*30mm
(A) x 15pcs	(B) x 3pcs	(D) x 20pcs

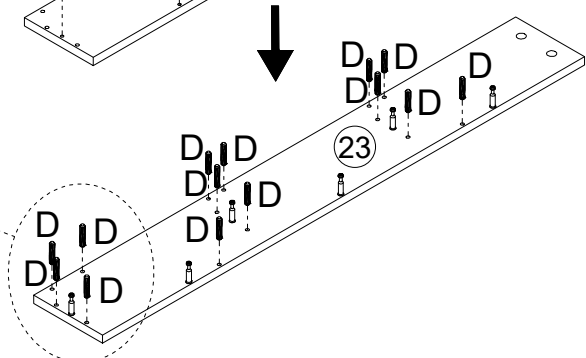
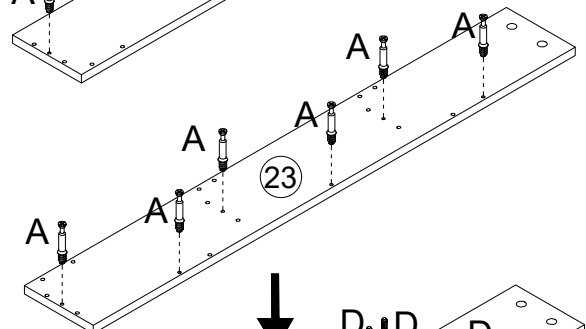
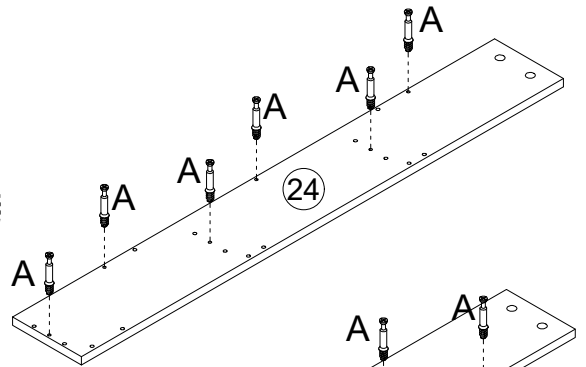
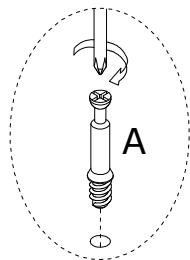
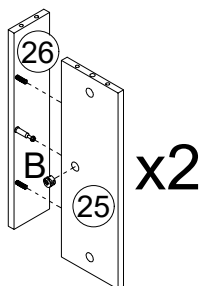
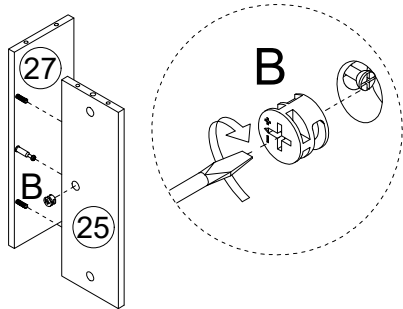
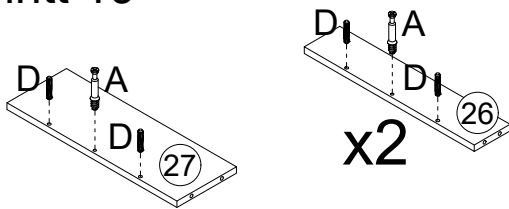

Step 20
Schritt 20



Ø15*9mm

(B) x 3pcs

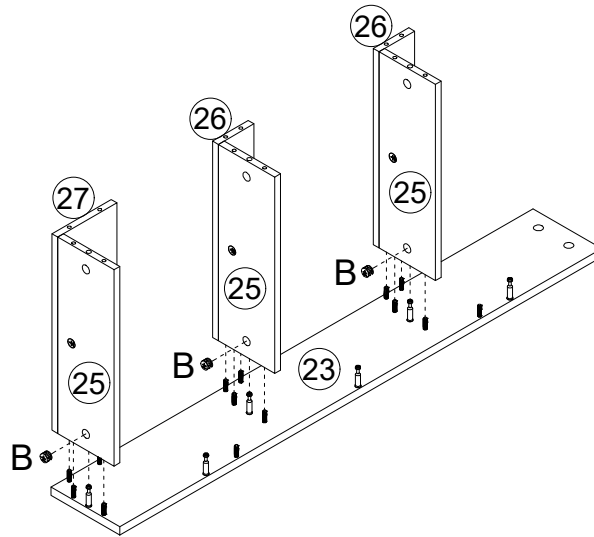
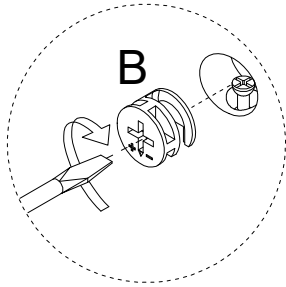

Step 21
Schritt 21



Ø15*9mm

(B) x 3pcs

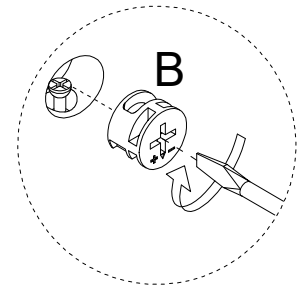
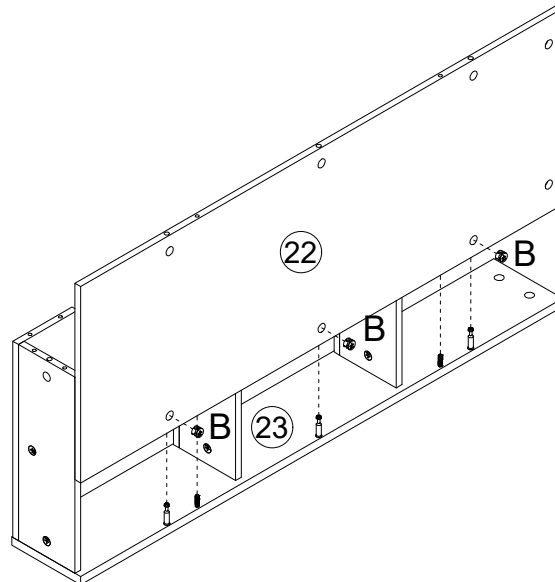

Step 22
Schritt 22



6*30mm

(D) x 14pcs

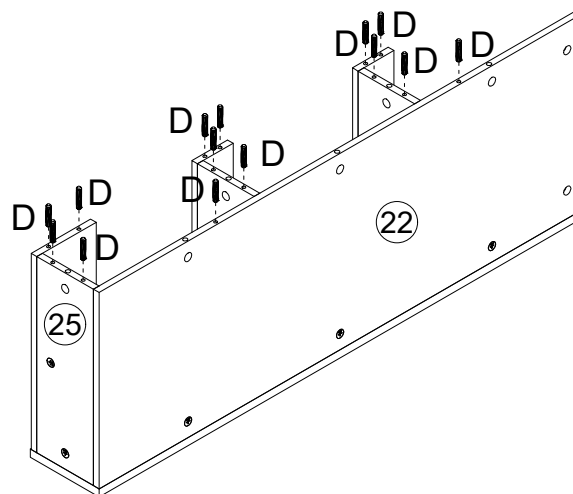
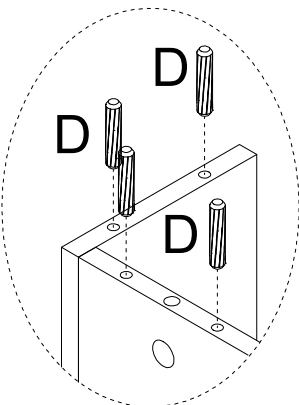

Step 23 Schritt 23



Ø15*9mm

(B) x 6pcs

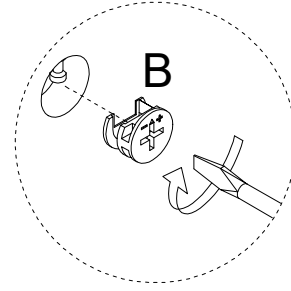
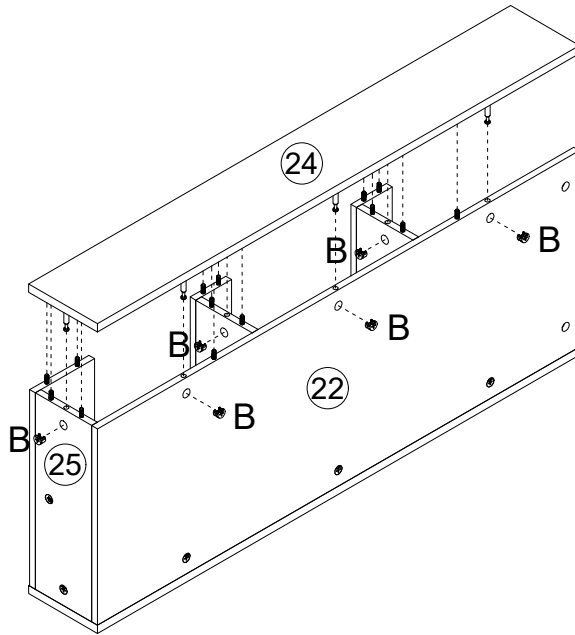

Step 24 Schritt 24

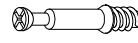

Ø6*35mm

(A) x 16pcs



Ø15*9mm

(B) x 2pcs



6*30mm

(D) x 6pcs

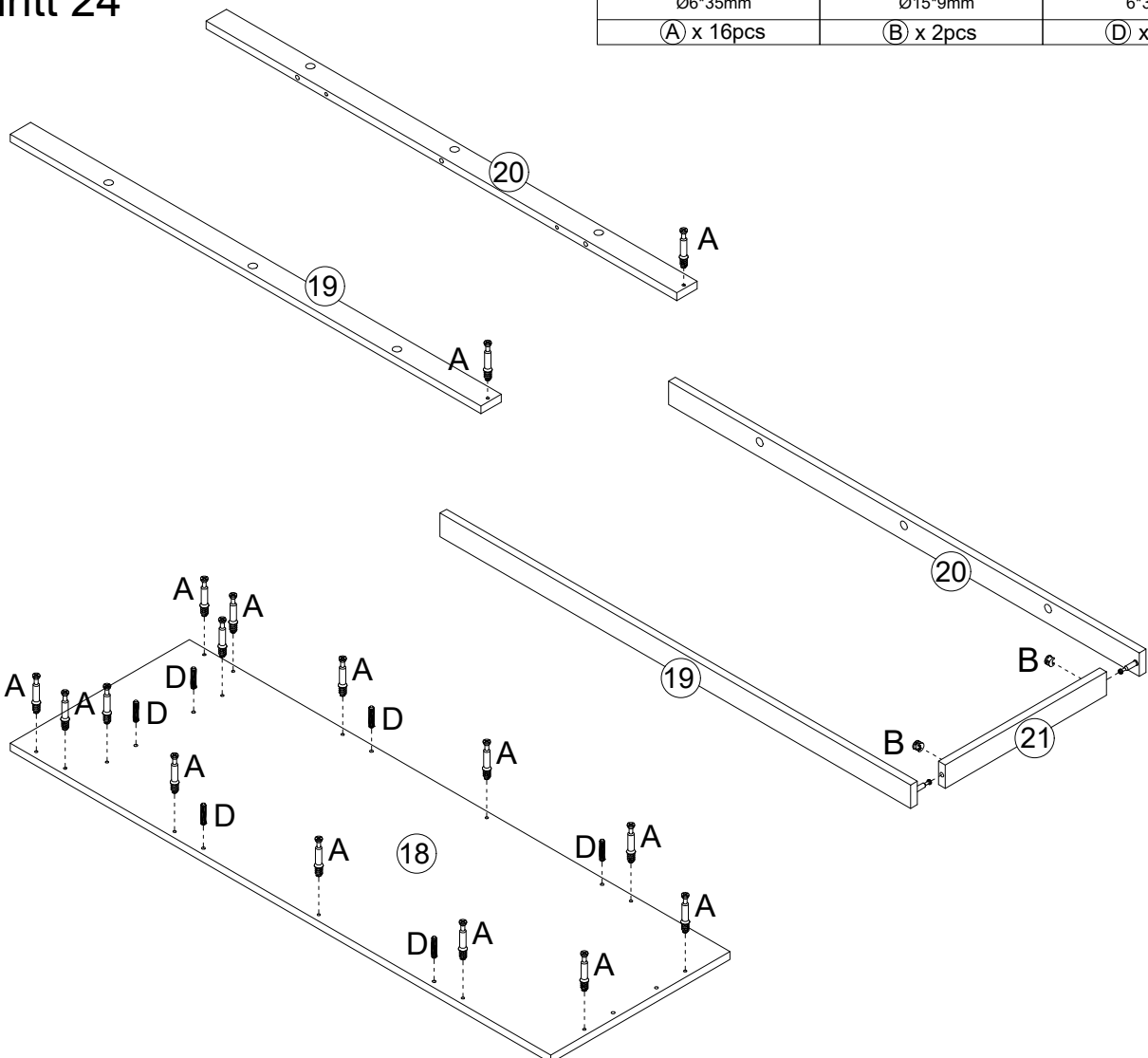

Step 25
Schritt 25



Ø15*9mm

(B) x 8pcs

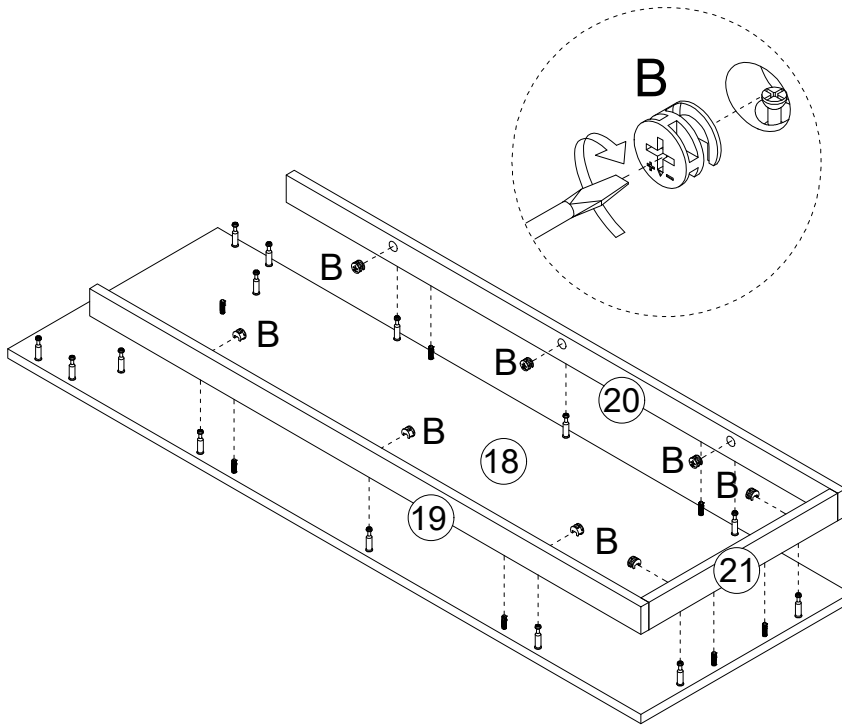

Step 26
Schritt 26



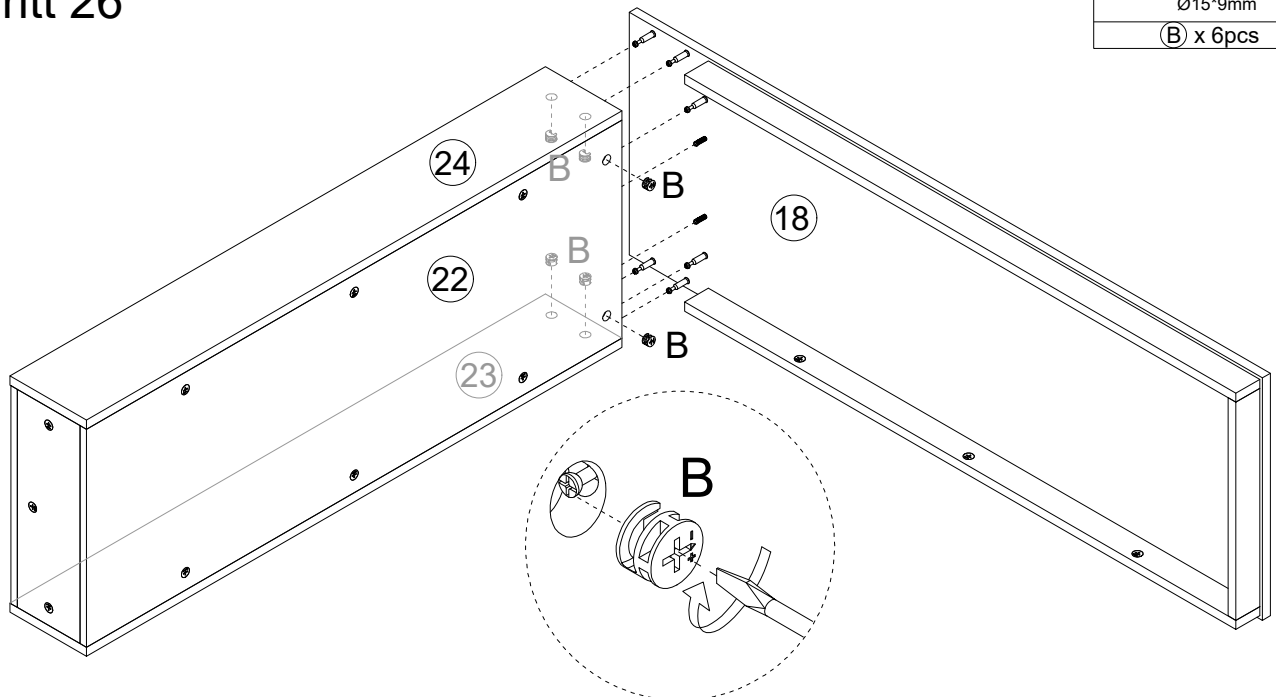

Ø15*9mm

(B) x 6pcs



Step 27
Schritt 27

		
30*15mm	Ø20mm	Ø15mm
(K) x 4pcs	(L) x 8pcs	(M) x 2pcs

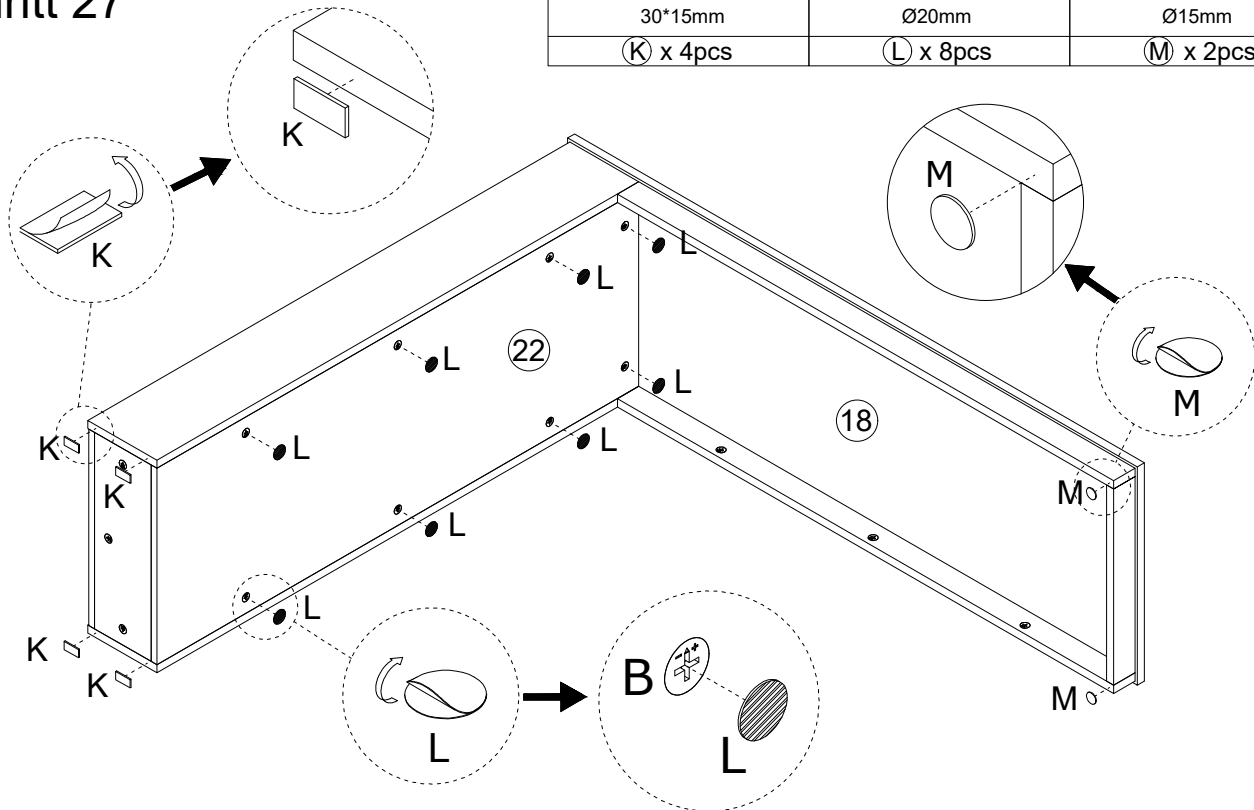

Step 28
Schritt 28

