

CALYPSO

WATCHES

IKMK5796M

MANUAL DE INSTRUCCIONES

INSTRUCTION MANUAL

MANUEL D'INSTRUCTION

BETRIEBSANLEITUNG

MANUALE DI FUNZIONAMENTO

MANUAL DE INSTRUÇÕES

MODO DE VISUALIZACIÓN Y OPERACIÓN DE LOS BOTONES

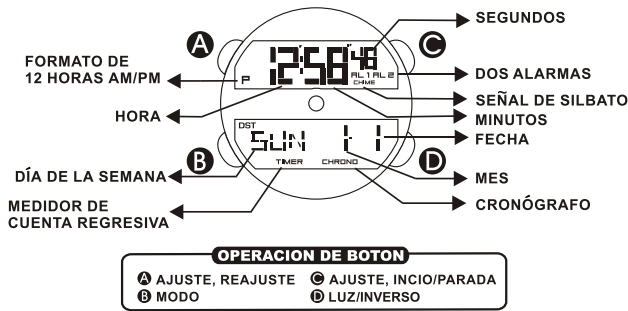

CUIDADO DE SU RELOJ

1. Este reloj contiene componentes electrónicos. No intente abrir la caja o remover la tapa posterior.
2. No oprimir los botones de su reloj bajo la superficie del agua, nadando o practicando submarinismo.
3. Si por cualquier motivo llegase a aparecer agua o condensación en el reloj hágalo chequear inmediatamente. El agua puede corroer los componentes electrónicos dentro de la caja.
4. Evite impactos severos. El reloj está diseñado para resistir impactos bajo condiciones normales de uso. Se sugiere no someterlo a impactos severos, al uso inadecuado o caídas bruscas sobre superficies duras.
5. Evite exponer el reloj a temperaturas extremas.
6. Limpie su reloj únicamente con agua y un paño suave. Evite el uso de productos químicos especialmente de jabón.
7. Mantenga su reloj lejos de cualquier campo eléctrico o estático.

COMO CAMBIAR EL MODO DE VISUALIZACIÓN

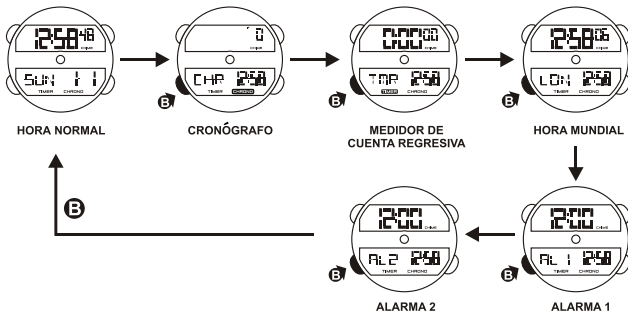

USO DE LA LUZ

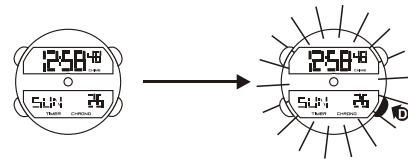

NOTAS:

1. La iluminación del reloj utiliza una luz electroluminiscente (EL) que tiende a perder potencia después de usos muy prolongados.
2. Bajo la luz solar directa es difícil ver la iluminación que proporciona la luz de la pantalla.

AJUSTE DE LA HORA NORMAL

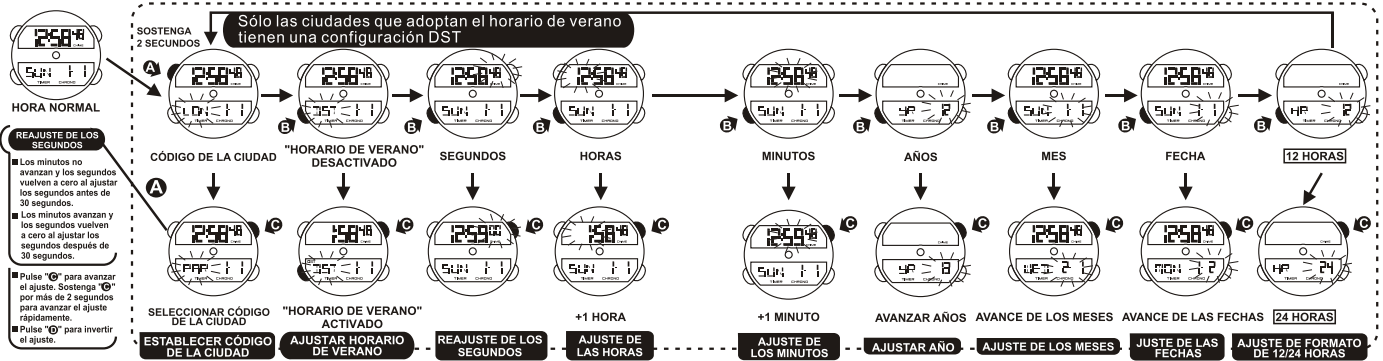

AJUSTE DE LA HORA NORMAL

AJUSTE DE LA ALARMA

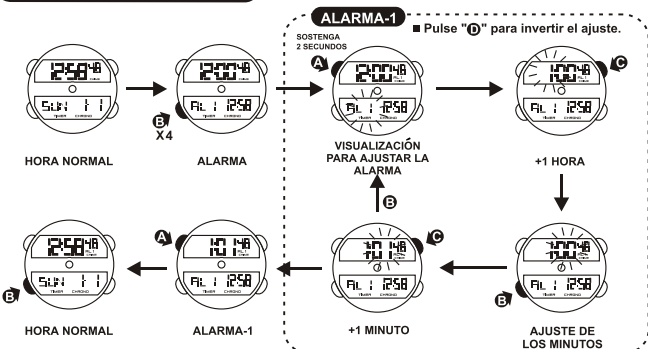

AJUSTE DE LA ALARMA

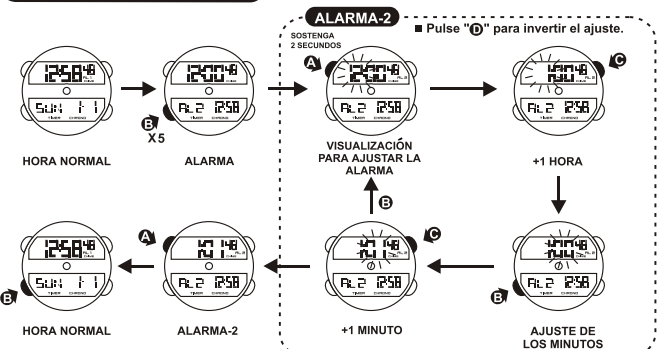

AJUSTE DE LA ALARMA-1 Y SEÑAL HORARIA (ENCENDIDA/APAGADA)

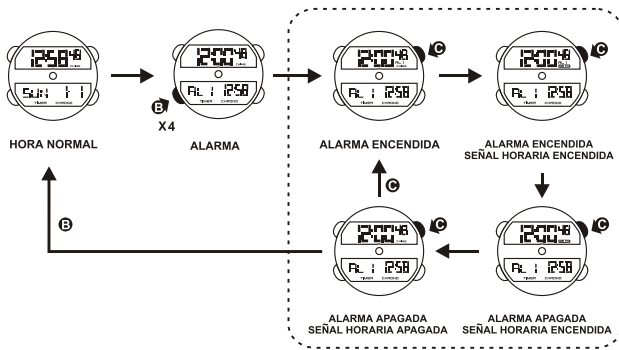

CÓMO AJUSTAR LA PRESENTACIÓN DE LA ALARMA 2

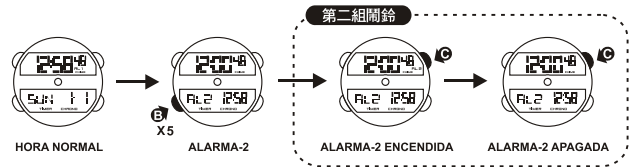

COMO UTILIZAR EL CRONÓGRAFO

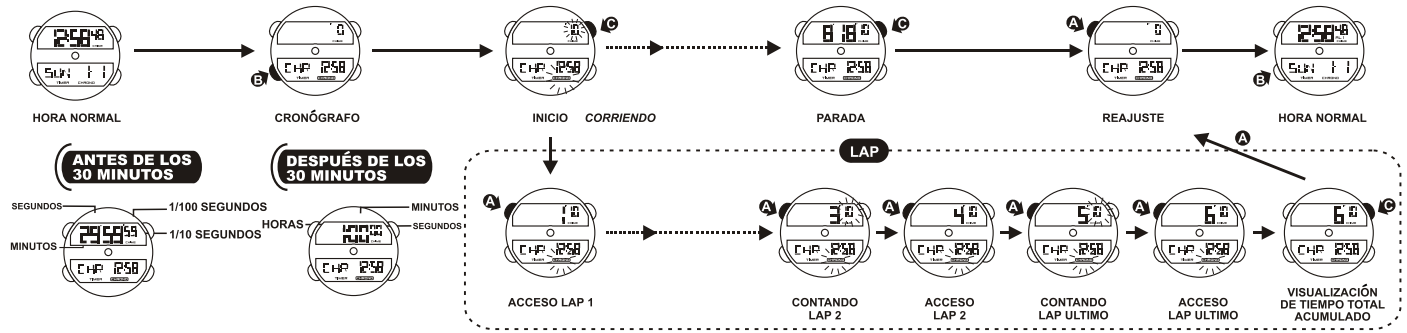

COMO UTILIZAR EL MEDIDOR DE CUENTA REGRESIVA

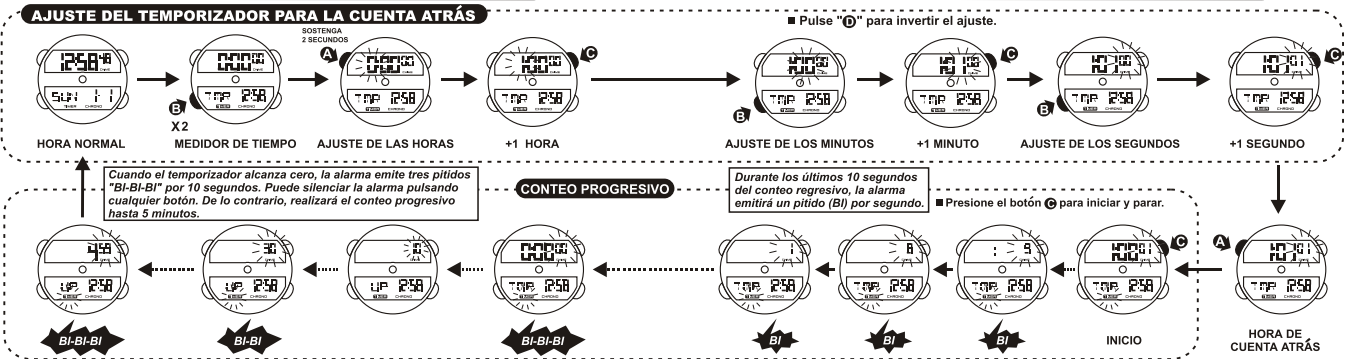

COMO AJUSTAR LA HORA MUNDIAL

Sólo las ciudades que adoptan el horario de verano tienen una configuración DST

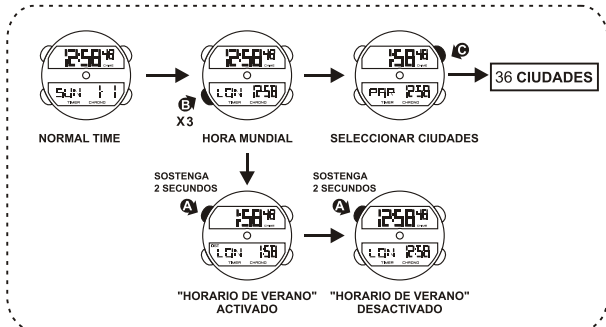

COMO AJUSTAR LA HORA MUNDIAL

36 nombres de ciudades (la x representa la falta de horario de verano, mientras que v representa una función de horario de verano seleccionable)

Diferencia de GMT	-11	-10	-9	-8	-7	-6	-5	-4	-3	-2	-1	0	0	1	1	2	2	2
CÓDIGO DE LA CIUDAD	PPG	HNL	ANC	LAX	DEN	CHI	NYC	CCS	RIO	-2	RAI	GMT	LON	PAR	BER	ATH	CAI	JRS
HORARIO DE VERANO	X	X	V	V	V	V	V	X	V	X	X	X	V	V	V	V	V	V
NOMBRE DE LA CIUDAD	Samoa	Honolulu	Anchorage	Los Angeles	Denver	Chicago	Nueva York	RiodelJaneiro	Caracas	Prata	Greenwich	Londres	Paris	Berlin	Athens	Cairo	Jerusalén	
Diferencia de GMT	3	3	3.5	4	4.5	5	5.5	6	6.5	7	8	8	9	9	9.5	10	11	12
CÓDIGO DE LA CIUDAD	JED	MOW	THR	DXB	KBL	KHI	DEL	DAC	RGN	BKK	HKG	BJS	SEL	TYO	ADL	SYD	NOU	WLG
HORARIO DE VERANO	X	V	X	X	X	X	X	X	X	X	X	X	X	X	V	V	X	V
NOMBRE DE LA CIUDAD	Jeddah	Moscú	Telavín	Dubai	Kabul	Karachi	Delhi	Dacca	Yangon	Bangkok	Hong Kong	Pekín	Seul	Tokio	Adelaida	Sydney	Numea	Wellington



En aplicación de la normativa sobre los desechos de equipos eléctricos y electrónicos, los productos de relojería de cuarzo que se encuentran al final de su vida útil deben ser sometidos a una recogida selectiva en vistas a su posterior tratamiento. También puede depositar nuestros productos de relojería de cuarzo en uno de nuestros puntos de venta autorizados, así como en cualquier punto de recogida habilitado. La recogida selectiva, el tratamiento, la valoración y el reciclaje contribuyen a la salvaguarda de nuestro medio ambiente y a la protección de nuestra salud.

REGULAR DISPLAY AND BUTTON OPERATION

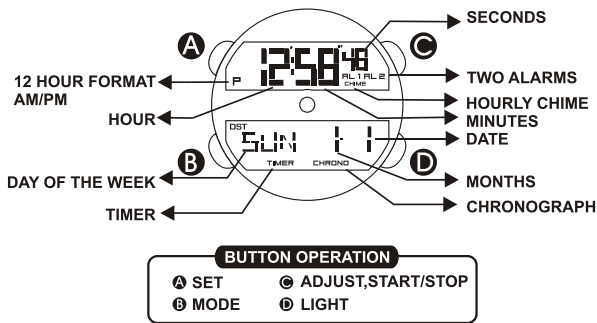

CARE OF YOUR WATCH

1. This watch contains precise electronic components. Never attempt to open the case or remove the back cover.
2. Do not operate buttons while underwater, or while swimming or diving.
3. Should water or condensation appear in the watch, immediately have the watch checked. Water can corrode electronic parts inside the case.
4. Avoid severe impact: The watch is designed to withstand impact under normal use. Do not subject it to severe impacts or rough usage, and do not drop it onto hard surfaces.
5. Avoid exposing the watch to temperature extremes.
6. Clean the watch with a soft cloth and clean water only. Avoid using chemicals, especially soap.
7. Keep your watch away from strong electric field and static electricity.

HOW TO CHANGE THE DISPLAY MODE

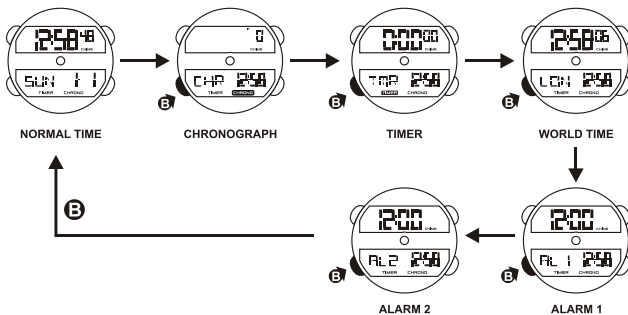

HOW TO USE EL LIGHT

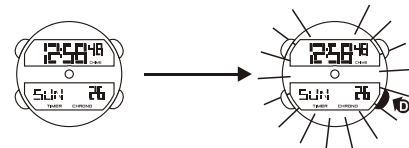

- NOTE:**
1. This watch features an electro-luminescent (EL) backlight, watch tends to lose illuminating power after very long use.
 2. The illumination provided by backlight may be hard to see under direct sunlight.

HOW TO SET NORMAL TIME

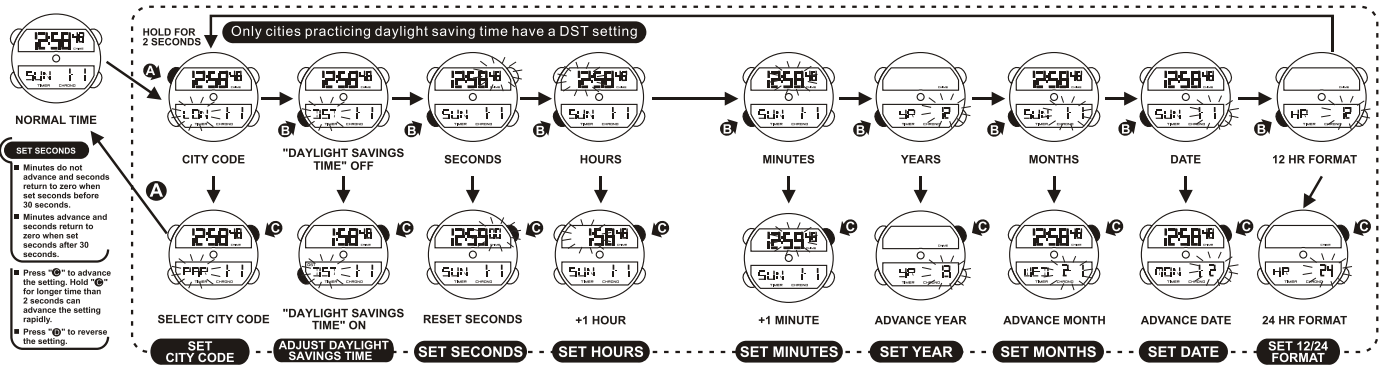

HOW TO SET ALARM TIME

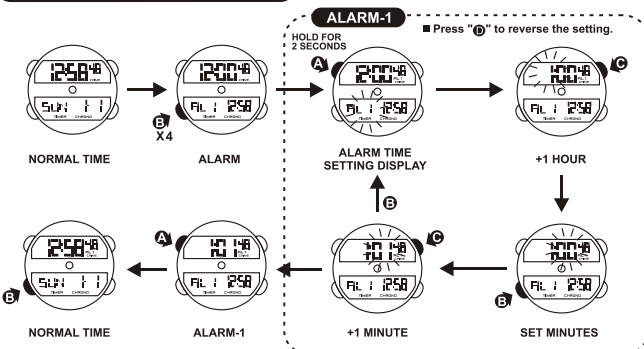

HOW TO SET ALARM TIME

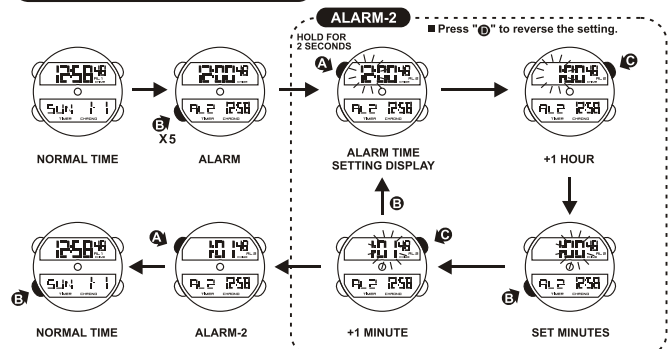

HOW TO USE ALARM-1 AND CHIME DISPLAY

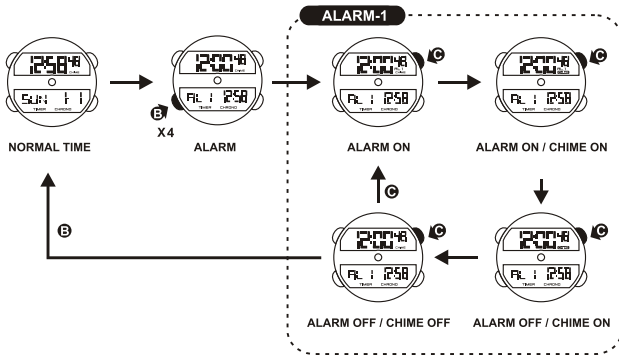

HOW TO SET ALARM-2 DISPLAY

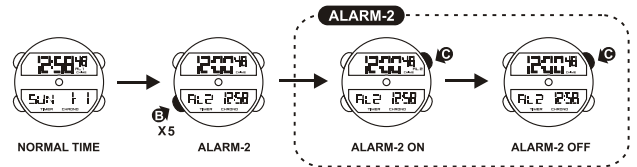

HOW TO SET THE CHRONOGRAPH

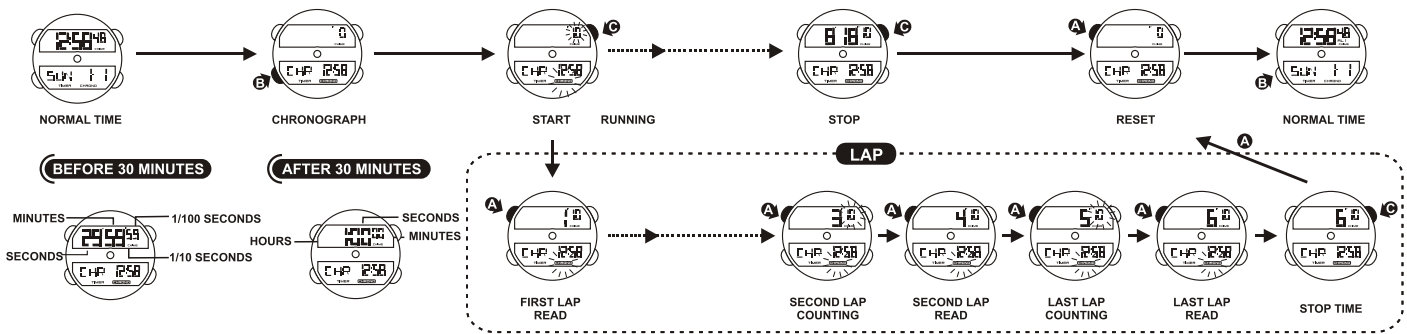

HOW TO SET TIMER

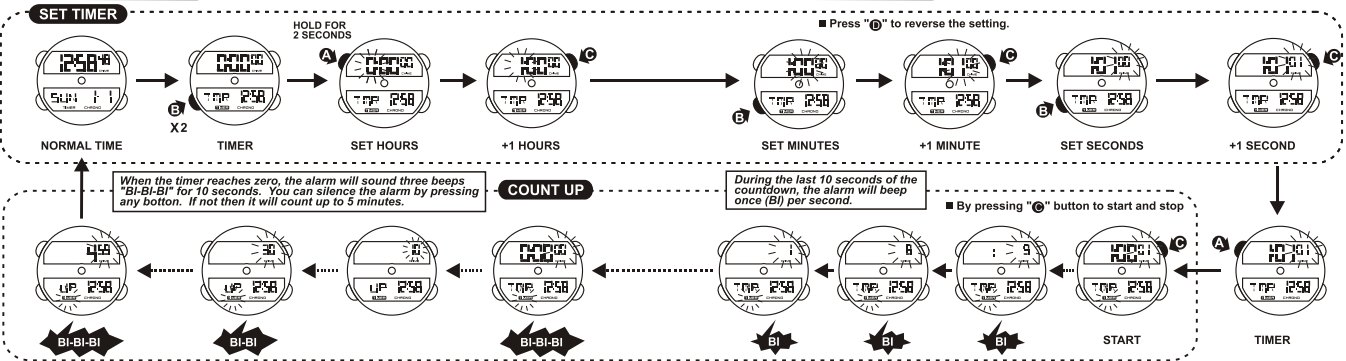

HOW TO SET WORLD TIME

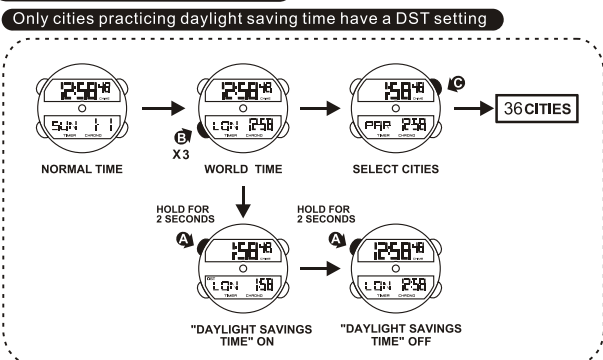

HOW TO SET WORLD TIME

36 city names (x represents no daylight saving time, v represents a selectable daylight saving time function)

GMT Difference	-11	-10	-9	-8	-7	-6	-5	-4	-3	-2	-1	0	1	2	2		
CITY CODE	PPG	NL	ANC	LAX	DEN	NY	CH	CCS	RIO	X	X	GMT	PAR	BER	ATH	CAI	JRS
DAYLIGHT SAVINGS TIME	X	X	V	V	V	V	V	X	X	X	X	X	X	X	V	V	V
CITY NAME	Samoa	Honolulu	Anchorage	Los Angel	Denver	Chicago	New York	Caracas	Rio De Janeiro	Prata	Greenwich	London	Paris	Berlin	Athens	Cairo	Jerusalem
GMT Difference	3	3	3.5	4	4.5	5	5.5	6	6.5	7	8	8	9	9	9.5	10	11
CITY CODE	JED	MOV	THR	DXB	KEL	KH	DEL	DAC	RGN	BKK	HKG	BUS	SEL	TYO	ADL	SYD	NOU
DAYLIGHT SAVINGS TIME	X	V	X	X	X	X	X	X	X	X	X	X	X	X	V	V	X
CITY NAME	Jeddah	Moscow	Tehran	Dubai	Kabul	Karachi	Delhi	Dacca	Yangon	Bangkok	Hong Kong	Beijing	Seoul	Tokyo	Adelaide	Sydney	Nouma
																	Wellington



By virtue of the regulations pursuant to the handling of waste products deriving from electronic and electrical equipment, end of lifecycle watch making products must be selectively collected for processing. You may therefore dispose of your quartz watch making products at any of our retail outlets or any other authorized collection point. The selective collection, processing, rating and recycling of these products helps contribute to safeguarding the environment and protecting our health.

AFFICHAGE NORMALE ET BOUTON D'UTILISATION

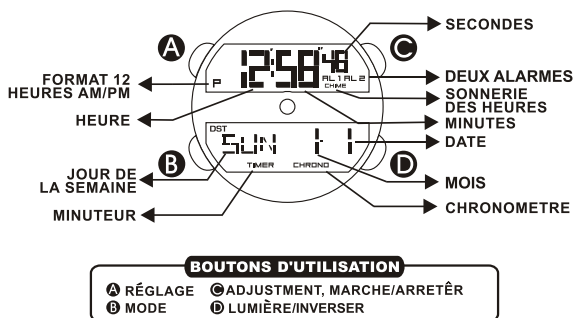

ENTRETIEN DE VOTRE MONTRE

1. Cette montre contient des composants électroniques de précision. Ne jamais tenter d'ouvrir le boîtier ou d'enlever le couvercle arrière.
2. Ne pas pousser les boutons sous l'eau ou lorsque vous nagez ou faites de la plongée.
3. Si de l'eau ou de la condensation apparaît à l'intérieur de la montre, faites la vérifier immédiatement. L'eau peut corroder les parties électroniques à l'intérieur de boîtier.
4. Éviter les chocs violents. Cette montre est conçue pour résister à des chocs occasionnés par un usage normal, il n'est pas recommandé de lui infliger des chocs sévères dus à un usage rude ou de la laisser tomber sur une surface dure.
5. Éviter d'exposer cette montre à des températures extrêmes.
6. Nettoyer la montre avec un chiffon doux et de l'eau propre uniquement. Éviter d'utiliser des produits chimiques, en particulier le savon.
7. Tenir la montre éloignée des fortes conditions de champ électrique et d'électricité statique.

COMMENT CHANGER LE MODE D'AFFICHAGE

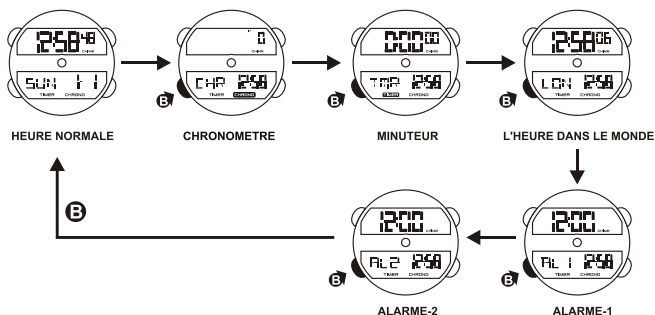

COMMENT ALLUMER LA LUMIÈRE ÉLECTRO-LUMINESCENTE

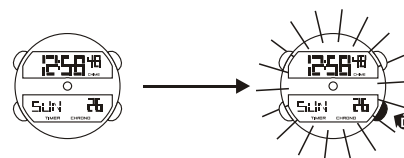

- NOTE:
1. La lumière de fond de cette montre utilise une lumière électro-luminescente, cette montre a tendance à perdre de sa puissance de luminosité après un très long usage.
 2. La luminosité de la lumière de fond peut être difficile à distinguer sous les rayons directs du soleil.

COMMENT RÉGLER L'HEURE NORMALE

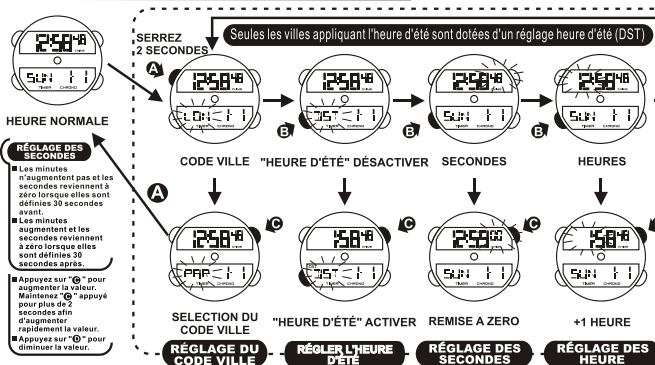

COMMENT RÉGLER L'HEURE NORMALE

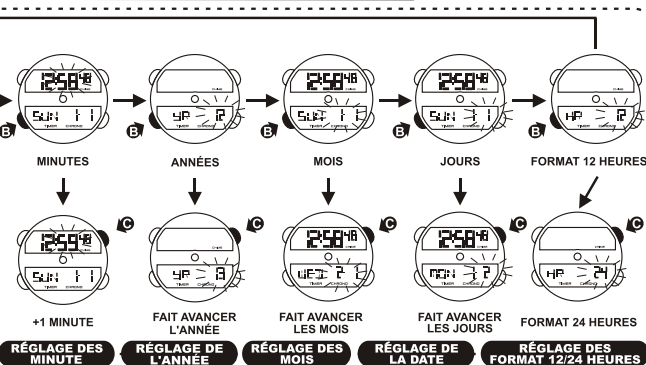

COMMENT RÉGLER L'ALARME

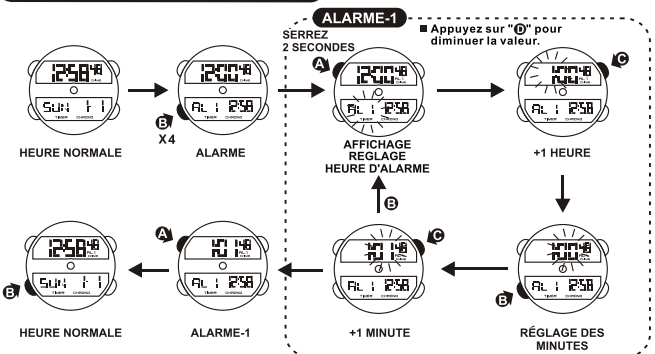

COMMENT RÉGLER L'ALARME

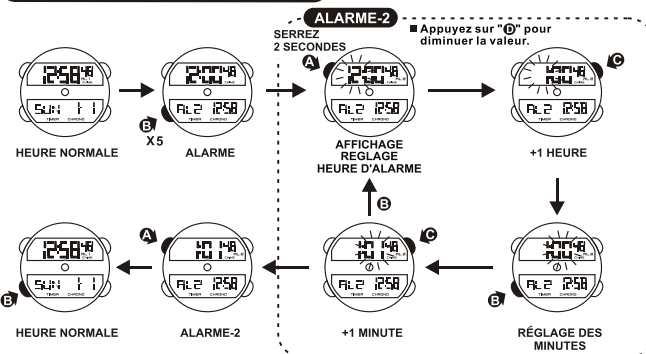

COMMENT UTILISER L’AFFICHAGE ALARME-1 ET CARILLON

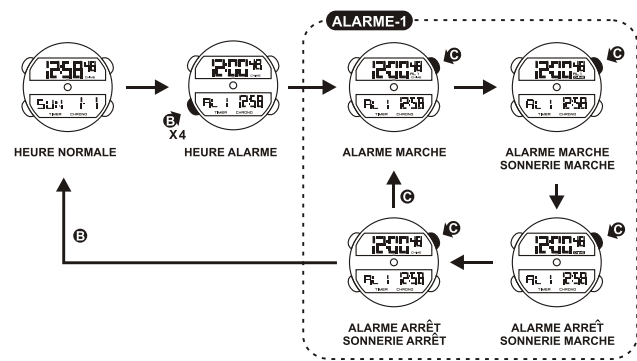

COMMENT RÉGLER L’AFFICHAGE ALARME-2

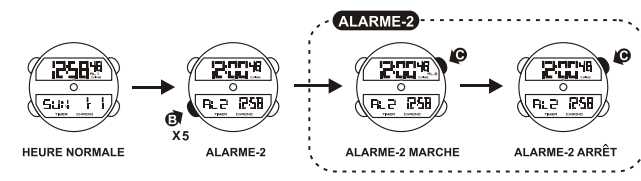

COMMENT UTILISER LE CHRONOMÈTRE

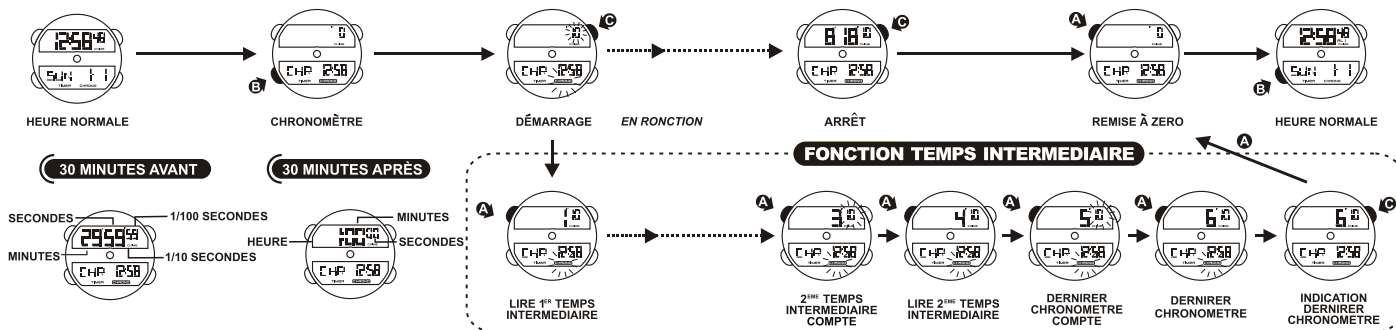

POUR UTILISER LE MINUTEUR DU COMPTE A REBOURS

POUR UTILISER LE MINUTEUR DU COMPTE A REBOURS

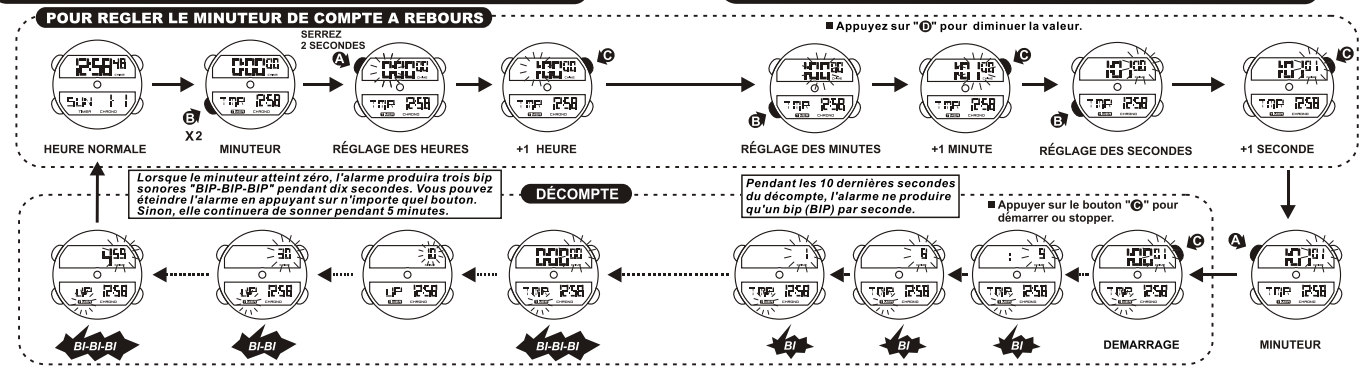

COMMENT RÉGLER L’HEURE DANS LE MONDE

COMMENT RÉGLER L’HEURE DANS LE MONDE

Seules les villes appliquant l'heure d'été sont dotées d'un réglage heure d'été (DST)

36 noms de ville (x indique pas d'heure d'été applicable, et v indique une fonction heure d'été sélectionnable)

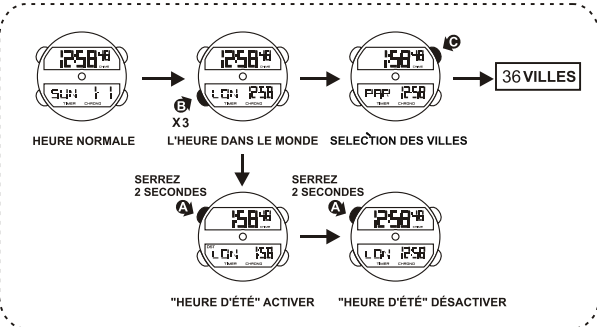

Différence GMT	-11	-10	-9	-8	-7	-6	-5	-4	-3	-2	-1	0	0	1	1	2	2	2
CODE VILLE	PPG	HNL	ANC	LAX	DEN	CHI	NYC	CCS	RIO	-2	RAI	GMT	LON	PAR	BER	ATH	CAI	JRS
HEURE D'ÉTÉ	X	X	V	V	V	V	V	X	V	X	X	X	V	V	V	V	V	V
NOM DE VILLE	Samoa	Honolulu	Anchorage	Denver/Los Angeles	Chicago	New York	Caracas	Rio De Janeiro		Prata	Greenwich	Londres	Paris	Berlin	Athens	Jerusalem		
Différence GMT	3	3	3.5	4	4.5	5	5.5	6	6.5	7	8	8	9	9	9.5	10	11	12
CODE VILLE	JED	MOW	THR	DXB	KBL	KHI	DEL	DAC	RGN	BKK	HKG	BJS	SEL	TYO	ADL	SYD	NOU	WLG
HEURE D'ÉTÉ	X	V	X	X	X	X	X	X	X	X	X	X	X	X	V	V	V	V
NOM DE VILLE	Jeddah	Moscou	Tehran	Dubaï	Kabul	Karachi	Delhi	Dacca	Yangon	Bangkok	Hong Kong	Beijing	Seoul	Tokyo	Adelaid	Nouméa	Sydney	Wellington



En application de la réglementation sur les déchets des équipements électriques et électroniques, les produits horlogers à quartz en fin de vie font l'objet d'une collecte sélective en vue de leur traitement. Vous pouvez ainsi déposer nos produits horlogers à quartz dans l'un de nos points de vente agréés, ainsi que dans tout point de collecte habilité. La collecte sélective, le traitement, la valorisation et le recyclage contribuent à la sauvegarde de notre environnement et à la protection de notre santé.

NORMALANZEIGE UND KNOPFFUNKTIONEN

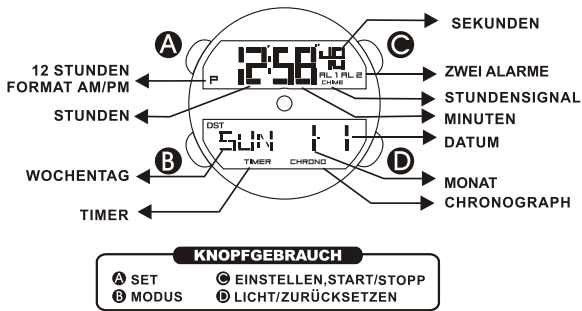

BEHANDLUNG IHRER UHR

1. Diese Uhr verfügt über präzise elektronische Komponenten. Versuchen Sie niemals, das Gehäuse zu öffnen oder den Deckel der Rückseite zu entfernen.
2. Betätigen Sie die Knöpfe nicht unter Wasser während dem Schwimmen oder Tauchen.
3. Sollte Wasser oder Kondensierung in der Uhr auftauchen, lassen Sie sie bitte sofort überprüfen, Feuchtigkeit kann Korrosion der elektrischen Teile verursachen.
4. Verhindern Sie harte Stöße. Die Uhr ist geeignet, nur Stößen unter normalen Bedingungen standzuhalten. Es wird nicht empfohlen, sie übermäßig starken Stößen oder grober Behandlung auszusetzen oder sie auf harte Oberflächen fallen zu lassen.
5. Vermeiden Sie es, die Uhr extremen Temperaturen auszusetzen.
6. Reinigen Sie die Uhr nur mit einem sanften Tuch und sauberem Wasser. Vermeiden Sie Chemikalien, insbesondere Seife.
7. Halten Sie Ihre Uhr fern von Umgebungen mit starkem Elektrofild und statischer Elektrizität.

DAS WECHSELN DES ANZEIGEMODUS

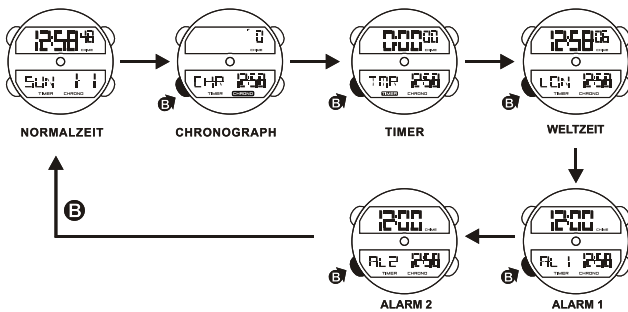

DIE EL BELEUCHTUNG

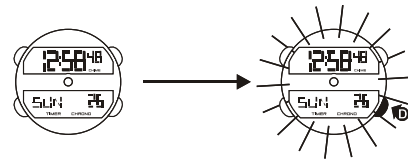

BEACHTEN SIE:

1. Die Beleuchtung der Uhr erfolgt durch ein elektrisch-lumineszierendes (EL) Licht. Die Uhr neigt nach sehr langer Benutzung dazu, die Beleuchtungskraft zu verlieren.
2. Die Beleuchtung der Uhr könnte schwer zu sehen sein, wenn unter direkten Sonnenlicht daraufgeschaut wird.

DAS EINSTELLEN DER NORMALZEIT

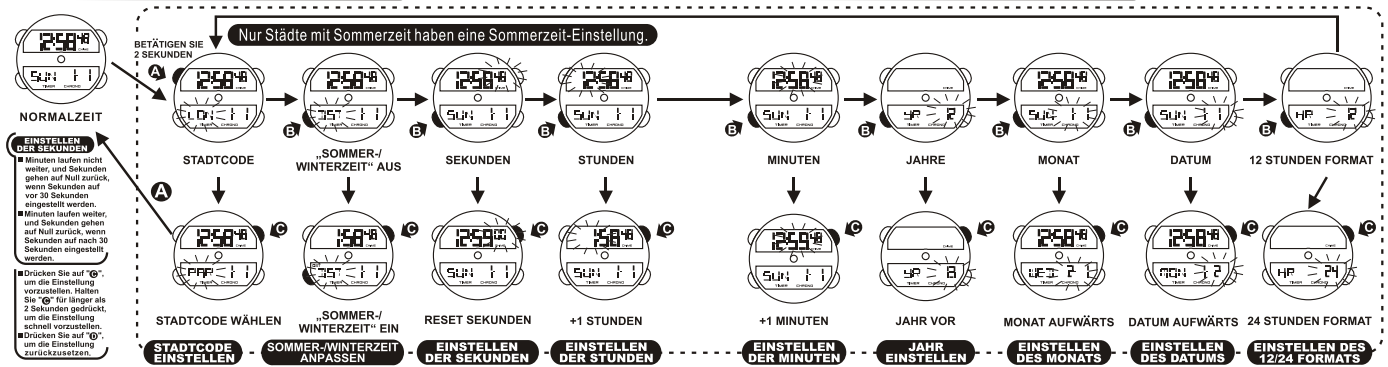

DAS EINSTELLEN DER ALARMZEIT

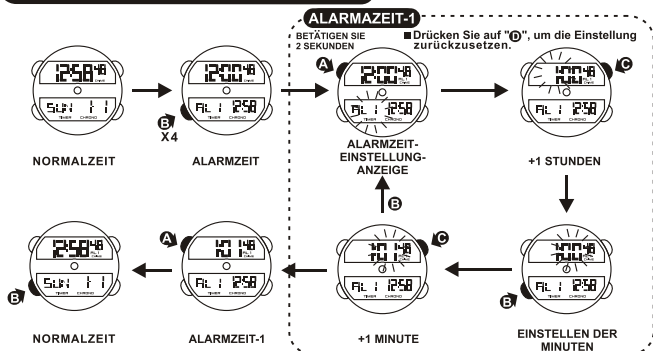

DAS EINSTELLEN DER ALARMZEIT

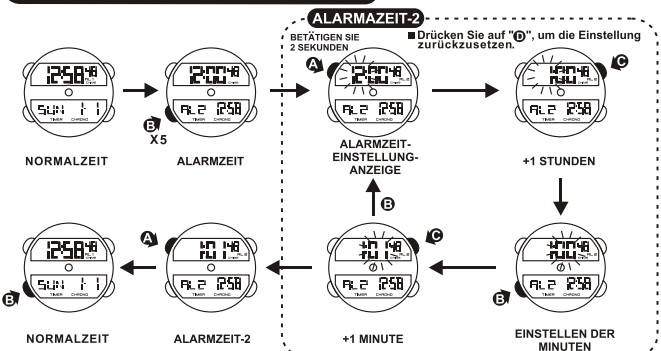

ALARM-1-ANZEIGE UND STUNDENSIGNAL-ANZEIGE

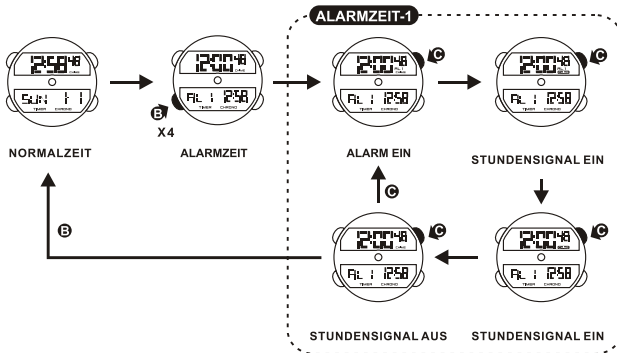

ALARM-1-ANZEIGE UND STUNDENSIGNAL-ANZEIGE

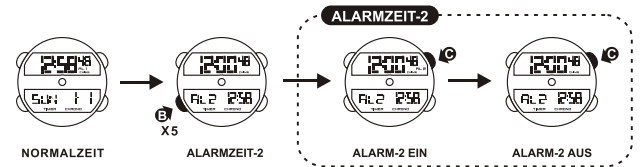

DIE BENUTZUNG DES CHRONOGRAPHEN

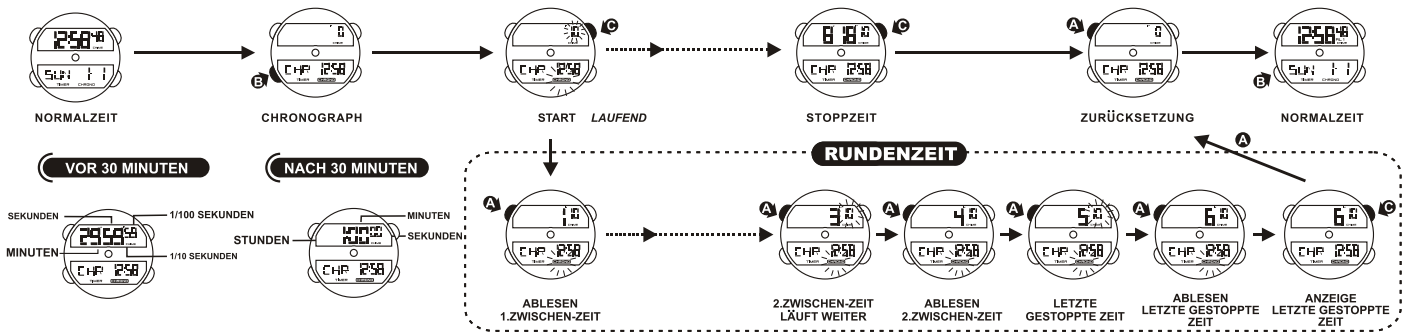

DAS EINSTELLEN DES COUNTDOWN TIMERS

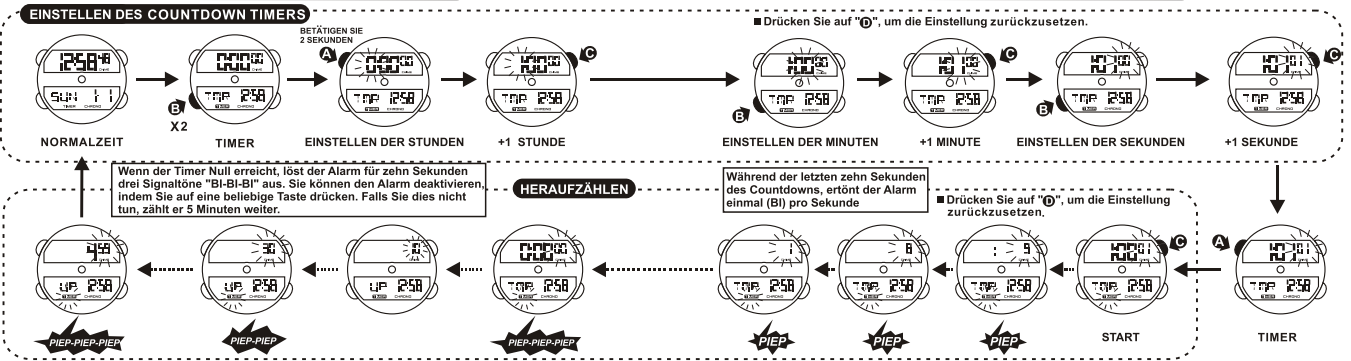

WELTZEIT EINSTELLEN

Nur Städte mit Sommerzeit haben eine Sommerzeit-Einstellung.

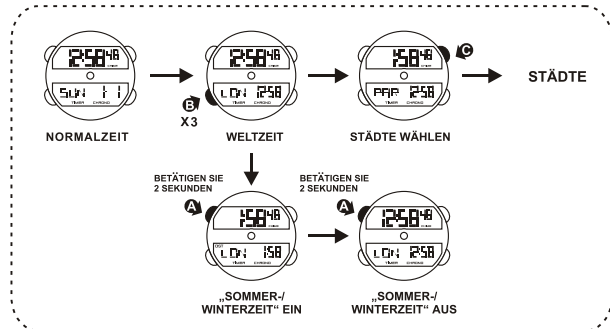

WELTZEIT EINSTELLEN

36 Städtenamen (x bedeutet keine Sommerzeit, v bedeutet wählbare Sommerzeitfunktion)

GMT Unterschied	-11	-10	-9	-8	-7	-6	-5	-4	-3	-2	-1	0	0	1	1	2	2	2
STADTCODE	PPG	HNL	ANC	LAX	DEN	CHI	NYC	CCS	RIO	-2	RAI	GMT	LON	PAR	BER	ATH	CAI	JRS
SOMMER-/ WINTERZEIT	x	x	v	v	v	v	x	x	v	x	x	x	x	x	x	v	v	v
STADTNAME	Samoa	Honolulu	Anchorage	Los Angeles	Denver	Chicago	New York	Caracas	Rio de Janeiro		Prata	Greenwich	London	Paris	Berlin	Athens	Kairo	Jerusalem
GMT Unterschied	3	3	3.5	4	4.5	5	5.5	6	6.5	7	8	8	9	9	9.5	10	11	12
STADTCODE	JED	MOW	THR	DXB	KBL	KHI	DEL	RGN	BKK	HKG	BJS	SEL	TYO	ADL	SYD	NOU	WLG	
SOMMER-/ WINTERZEIT	x	v	x	x	x	x	x	x	x	x	x	x	x	x	v	x	v	
STADTNAME	Jeddah	Moskau	Tehran	Dubai	Kabul	Karachi	Delhi	Dhaka	Yangon	Bangkok	Hongkong	Beijing	Seoul	Tokio	Adelaid	Sydney	Noumea	Wellington



Gemäß den Bestimmungen über die Behandlung von Abfällen durch Elektronik- und Elektro-Altgeräte sind Quarzuhrenprodukte, deren Lebensdauer abgelaufen ist, selektiv zu sammeln, um sie dem Recycling zuzuführen. Sie können Ihre Quarzuhrenprodukte daher in einer unserer Verkaufsstellen oder an einer beliebigen Sammelstelle abgeben. Die selektive Sammlung, die Verarbeitung, die Bewertung und das Recycling dieser Produkte ist ein Beitrag zum Umweltschutz und zum Schutz unserer Gesundheit.

REGOLARE DISPLAY E FUNZIONAMENTO DEI PULSANTI

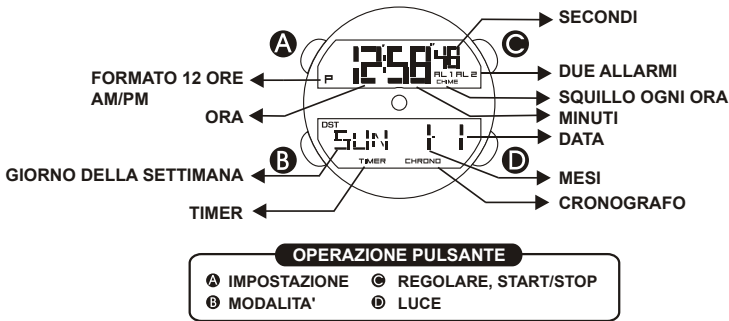

PRENDITI CURA DEL TUO OROLOGIO

1. Questo orologio contiene componenti elettromeccanici di alta qualità. Non tentare mai di aprire il contenitore o di rimuovere il coperchio posteriore.
2. Non azionare i pulsanti mentre si è sott'acqua, o durante il nuoto o l'immersione.
3. Se nell'orologio dovesse apparire acqua o condensa, far controllare immediatamente l'orologio. L'acqua può danneggiare le parti elettroniche dell'orologio.
4. Evitare urti forti: L'orologio è progettato per resistere agli urti in condizioni d'uso normali. Non sottoporlo a forti impatti o ad un uso brusco, e non farlo cadere su superfici dure.
5. Evitare di esporre l'orologio a temperature estreme.
6. Pulire l'orologio con un panno morbido e pulirlo solo con acqua. Evitare l'uso di prodotti chimici, specialmente sapone.
7. Tenere l'orologio lontano da forti campi elettrici e da elettricità statica."

COME CAMBIARE LA MODALITÀ DI VISUALIZZAZIONE

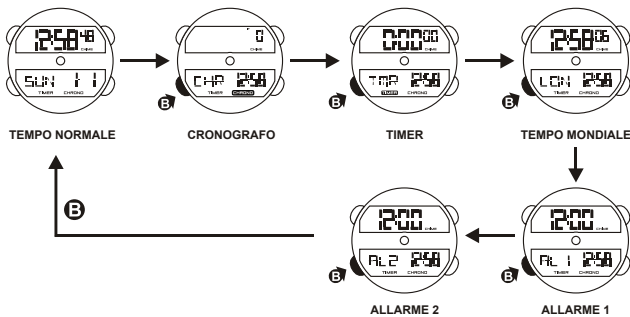

COME USARE LA LUCE

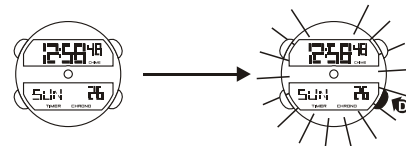

- NOTA:**
1. Questo orologio è dotato di una retroilluminazione elettroluminescente (EL), l'orologio tende a perdere potenza illuminante dopo un uso molto lungo
 2. L'illuminazione fornita dalla retroilluminazione può essere difficile da vedere sotto la luce diretta del sole

COME IMPOSTARE IL TEMPO NORMALE

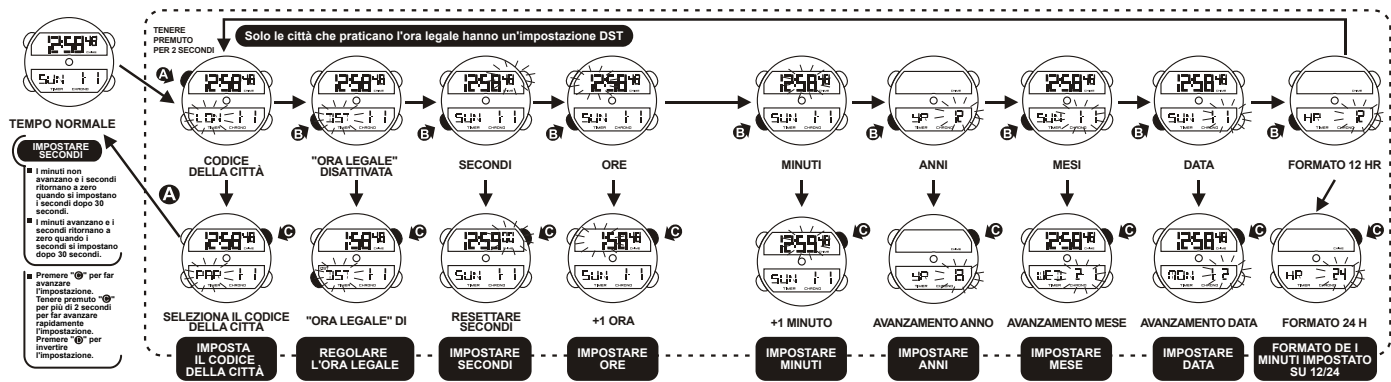

COME IMPOSTARE IL TEMPO DELL' ALLARME

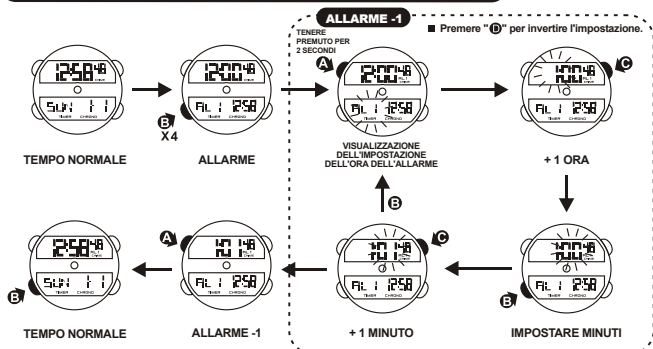

COME IMPOSTARE IL TEMPO DELL' ALLARME

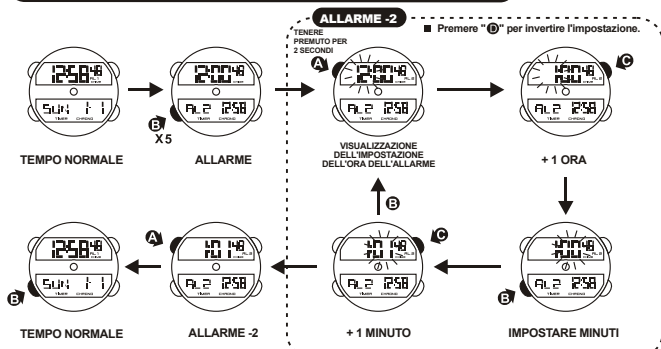

COME IMPOSTARE IL TEMPO DELL' ALLARME

COME IMPOSTARE LA VISUALIZZAZIONE DELL'ALLARME-2

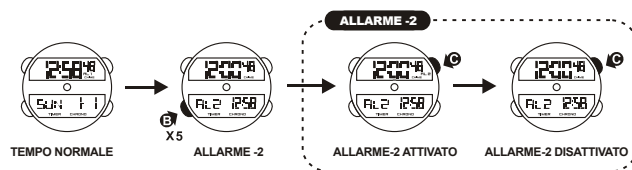
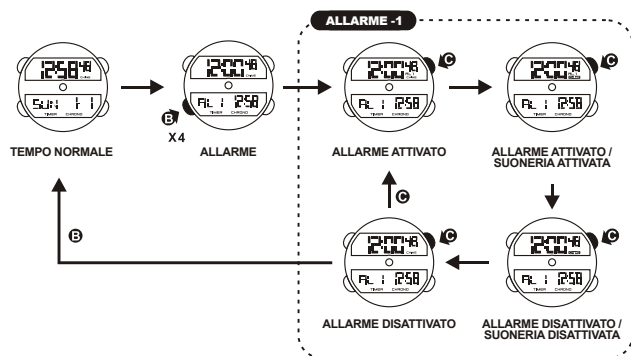

COME IMPOSTARE IL CRONOGRAFO

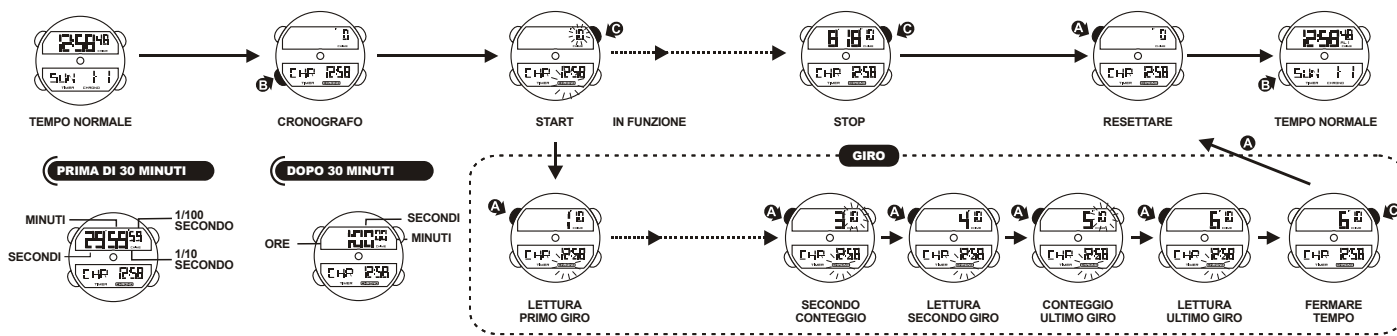

COME IMPOSTARE IL TIMER

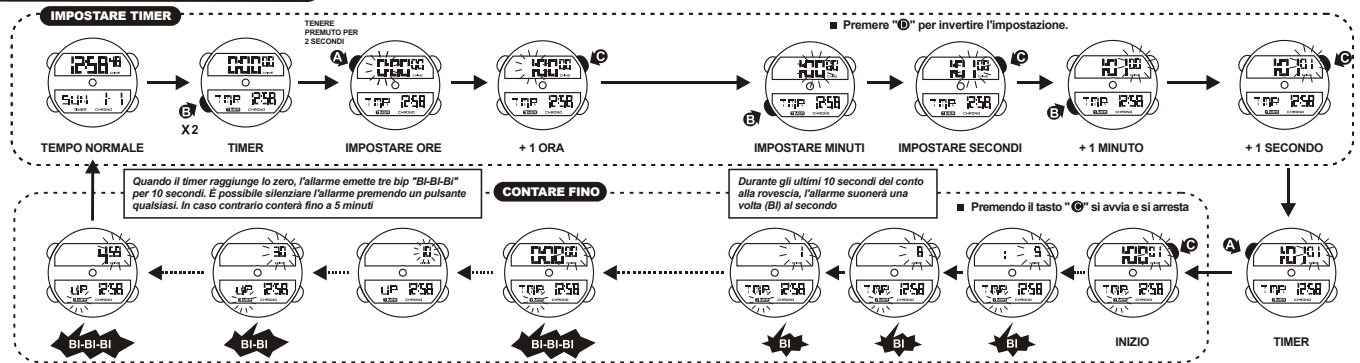

COME IMPOSTARE IL TEMPO DEL MONDO

Solo le città che praticano l'ora legale hanno un'impostazione DST

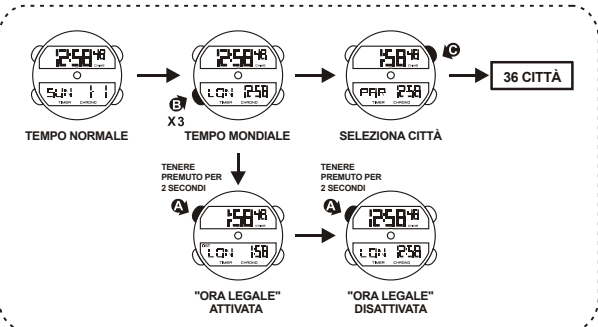

COME IMPOSTARE IL TEMPO DEL MONDO

36 nomi di città (x rappresenta l'assenza dell'ora legale, v rappresenta una funzione selezionabile dell'ora legale)

Differenza GMT	-11	-10	-9	-8	-7	-6	-5	-4	-3	-2	-1	0	1	1	2	2	2
CODICE CITTÀ	PPG	NL	ANC	LAX	DEN	NY	CH	CCS	RIO	-2	RA	GMT	PAR	PAR	BER	ATH	CAI
ORA LEGALE	X	X	V	V	V	V	X	X	X	X	X	X	X	X	V	V	V
NOME CITTÀ	Samoa	Honolulu	Anchorage	Los Angeles	Denver	Chicago	New York	Caracas	Rio de Janeiro	Praia	Greenwich	Londra	Parigi	Parigi	Berlino	Atene	Il Cairo
Differenza GMT	3	3	3.5	4	4.5	5	5.5	6	6.5	7	8	8	9	9	9.5	10	11
CODICE CITTÀ	JED	MOV	THR	DXB	KEL	KHI	DEL	DAC	RGN	BKK	HKG	BUS	SEL	TYO	ADL	SYD	NOU
ORA LEGALE	X	V	X	X	X	X	X	X	X	X	X	X	X	X	V	V	V
NOME CITTÀ	Gedda	Mosca	Teheran	Dubai	Kabul	Karachi	Delhi	Dacca	Yangon	Bangkok	Hong Kong	Pechino	Seoul	Tokyo	Adelaide	Sydney	Noumea
																	Wellington



Ai sensi dei regolamenti relativi alla manipolazione dei rifiuti provenienti da assemblaggi elettrici ed elettronici, i prodotti d'orologeria ormai inutilizzabili devono essere raccolti separatamente per consentirne il trattamento. In qualsiasi nostro punto vendita o punto di raccolta autorizzato troverà gli appositi contenitori per lo smaltimento dei componenti del Suo orologio al quarzo. La raccolta differenziata, il trattamento, la valorizzazione ed il riciclaggio di tali prodotti contribuiscono alla salvaguardia dell'ambiente ed alla produzione della nostra salute.

MOSTRADOR E FUNCIONAMENTO DOS BOTÕES

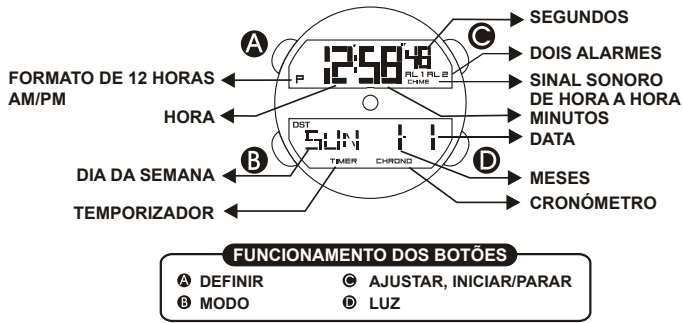

CUIDADOS A TER COM O SEU RELÓGIO

1. Este relógio contém componentes eletrônicos de precisão. Nunca tente abrir a caixa ou remover a tampa traseira.
2. Não utilize os botões debaixo de água quando estiver a nadar ou a mergulhar.
3. Caso exista água ou condensação no relógio, mande-o verificar imediatamente. A água pode corroer as partes eletrônicas no interior da caixa.
4. Evite o manuseamento brusco: O relógio foi projetado para resistir ao manuseamento em condições normais de utilização, sendo desaconselhável a sua utilização brusca ou queda em superfícies duras.
5. Evite expor o relógio a temperaturas extremas.
6. Limpe o relógio apenas com um pano macio e água limpa. Evite a utilização de produtos químicos, especialmente sabão.
7. Mantenha o seu relógio longe dos fortes campos magnéticos e da eletricidade estática."

COMO ALTERAR O MODO DE APRESENTAÇÃO

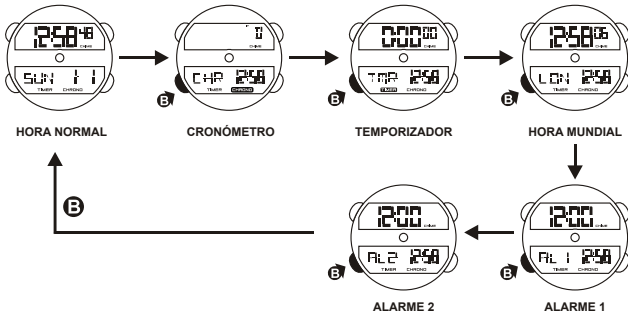

COMO UTILIZAR A LUZ EL

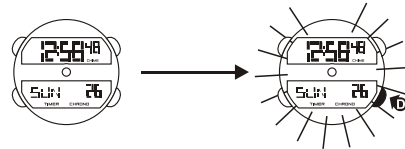

OBSERVAÇÃO:

1. Este relógio possui uma luz eletroluminescente (EL) de fundo, que tende a perder a sua potência após uma utilização muito longa.
2. A iluminação fornecida pela luz de fundo pode ser difícil de ver quando vista sob a luz solar direta.

COMO DEFINIR AS HORAS

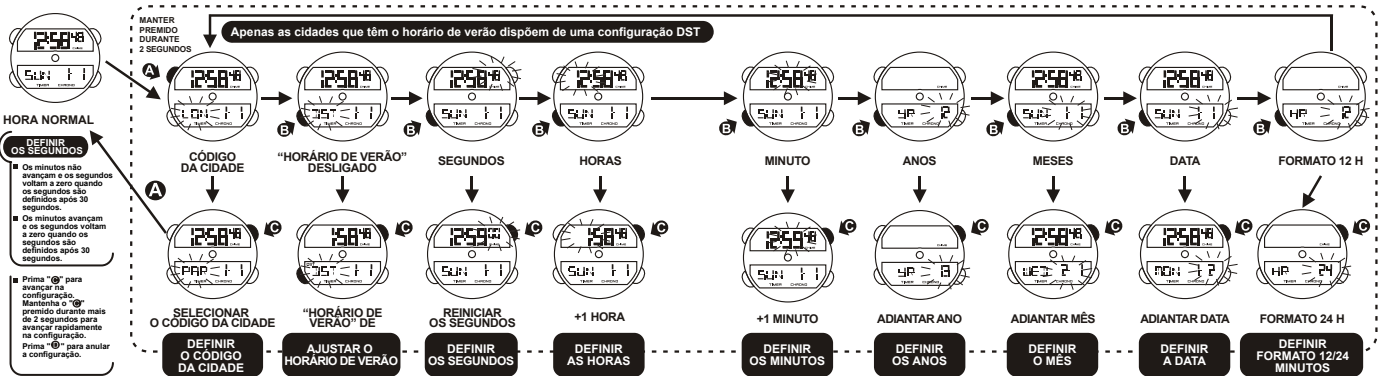

COMO DEFINIR O ALARME

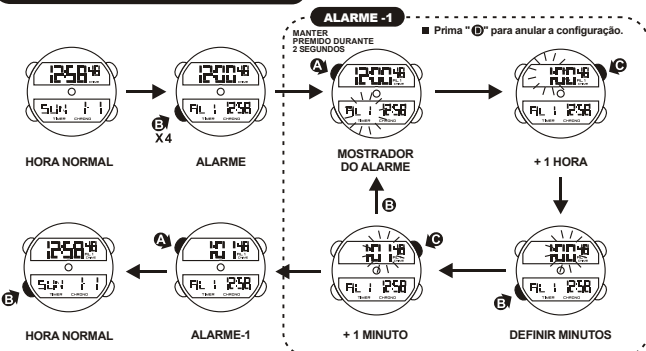

COMO DEFINIR O ALARME

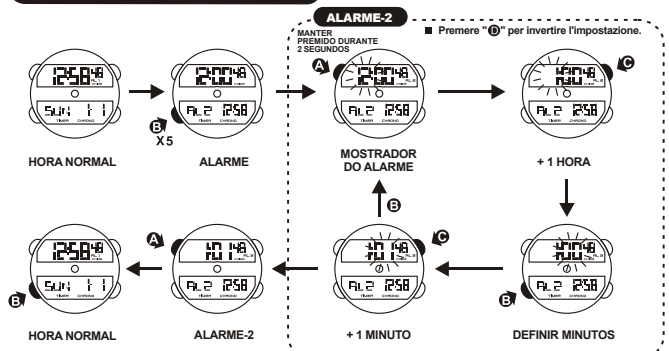

COMO DEFINIR O MOSTRADOR DO ALARME

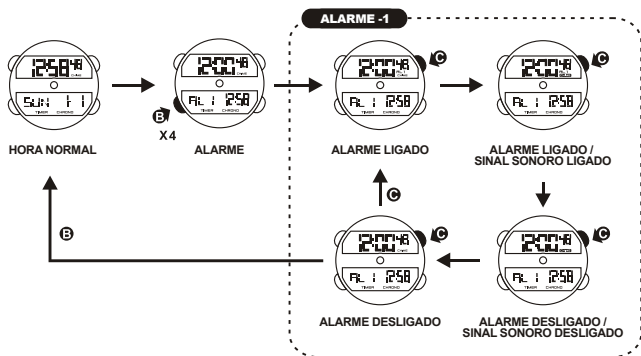

COMO DEFINIR O MOSTRADOR DO ALARME-2

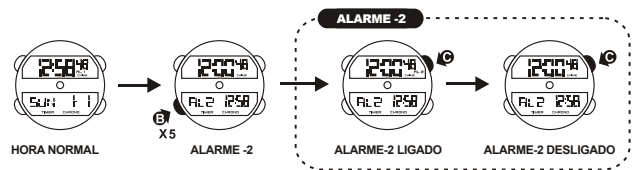

COMO DEFINIR O CRONÓMETRO

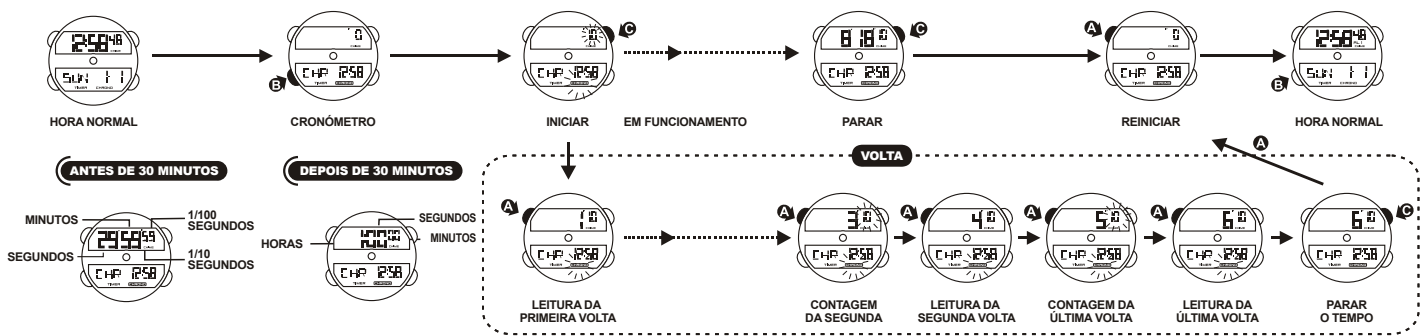

COMO DEFINIR O TEMPORIZADOR

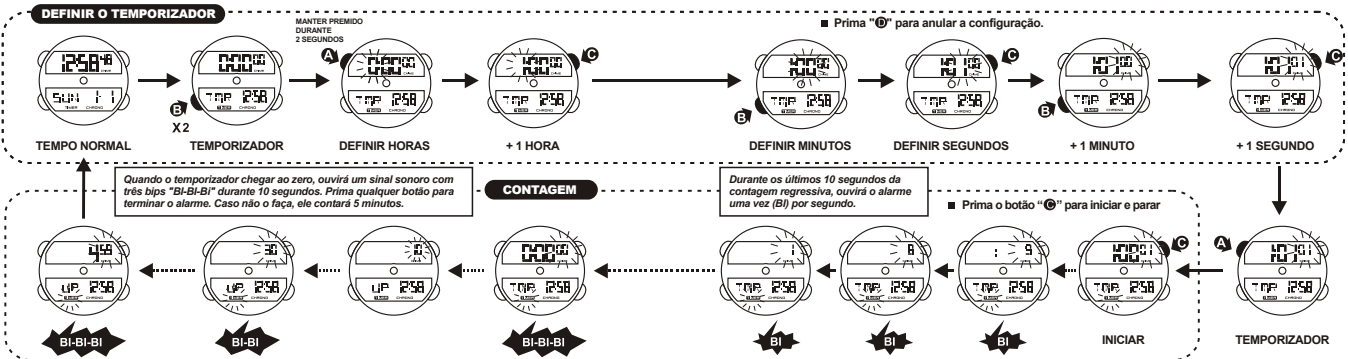

COMO DEFINIR A HORA MUNDIAL

Apenas as cidades que têm o horário de verão dispõem de uma configuração DST

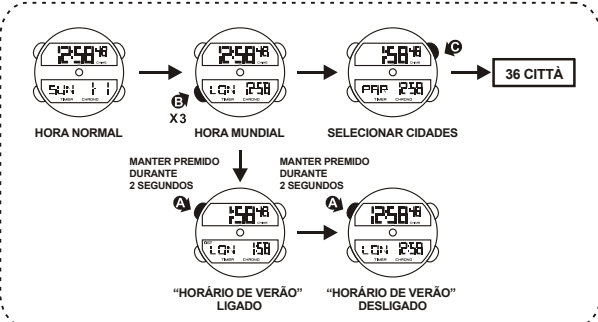

COMO DEFINIR A HORA MUNDIAL

36 nomi di città (x rappresenta l'assenza dell'ora legale, v rappresenta una funzione selezionabile dell'ora legale)

Diferença GMT	-11	-10	-9	-8	-7	-6	-5	-4	-3	-2	-1	0	1	2	2			
CÓDIGO DA CIDADE	PPG	NL	ANC	LAX	DEN	CH	NY	CCS	RIO	-2	RA	GMT	LVN	PAR	BER	ATH	CAI	JRS
HORÁRIO DE VERÃO	X	X	V	V	V	V	V	X	X	X	X	X	X	X	X	V	V	V
NOME DA CIDADE	Samoa	Honolulu	Anchorage	Los Angeles	Denver	Chicago	Nova Iorque	Caracas	Rio de Janeiro	Praia	Greenwich	Londres	Paris	Berlim	Athenas	Cairo	Jerusalém	
Diferença GMT	3	3	3.5	4	4.5	5	5.5	6	6.5	7	8	8	9	9.5	10	11	12	
CÓDIGO DA CIDADE	JED	MOV	THR	DXB	KEL	KH	DEL	DAC	RGN	BKK	HKG	BUS	SEL	TYO	ADL	SYD	NOU	VLG
HORÁRIO DE VERÃO	X	V	X	X	X	X	X	X	X	X	X	X	X	X	V	V	X	V
NOME DA CIDADE	Jeddah	Moscovo	Teerão	Dubai	Kabul	Carachi	Deli	Daca	Rangum	Bangkok	Hong Kong	Pequim	Seul	Toquio	A Adelaide	Sydney	Nouma	Wellington



Em cumprimento das regras sobre resíduos de equipamentos elétricos e eletrônicos, os produtos de relojoaria de quartzo que tenham atingido o final da sua vida útil devem ser recolhidos seletivamente para seu processamento posterior. Os nossos produtos de quartzo podem também ser depositados em um dos nossos pontos de venda autorizados bem como em qualquer local autorizado para esse fim. La collietta separada, o tratamento, a avaliação e a reciclagem contribuem para a proteção do nosso ambiente e da nossa saúde.