

DUMOS®

Drawer Dresser

Instruction Manual

CAB-2BC



1 Component List

A X1

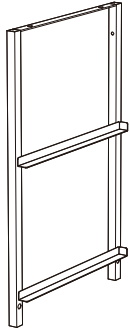

Side Frame

B X1

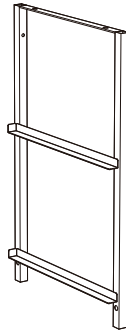

Side Frame

C X2

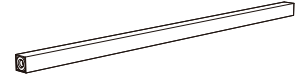

Cross Tube

D X2

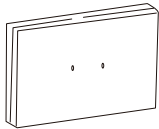

Drawer

E X2

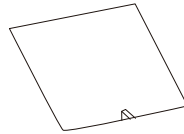

Base Board
for Drawer

F X1

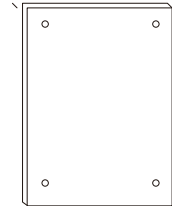

Top Board

2 Supplied Parts and Hardware

1 X4



Bolts
M6x25mm

2 X4



Bolts
M6x10mm

3 X2



Drawer Handle

4 X4



Bolts
M4x12mm

5 X4



Adjusting Foot

6 X2



Bolts & Tube
M4x60mm

7

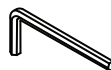

Wrench & Screwdriver

Step 1

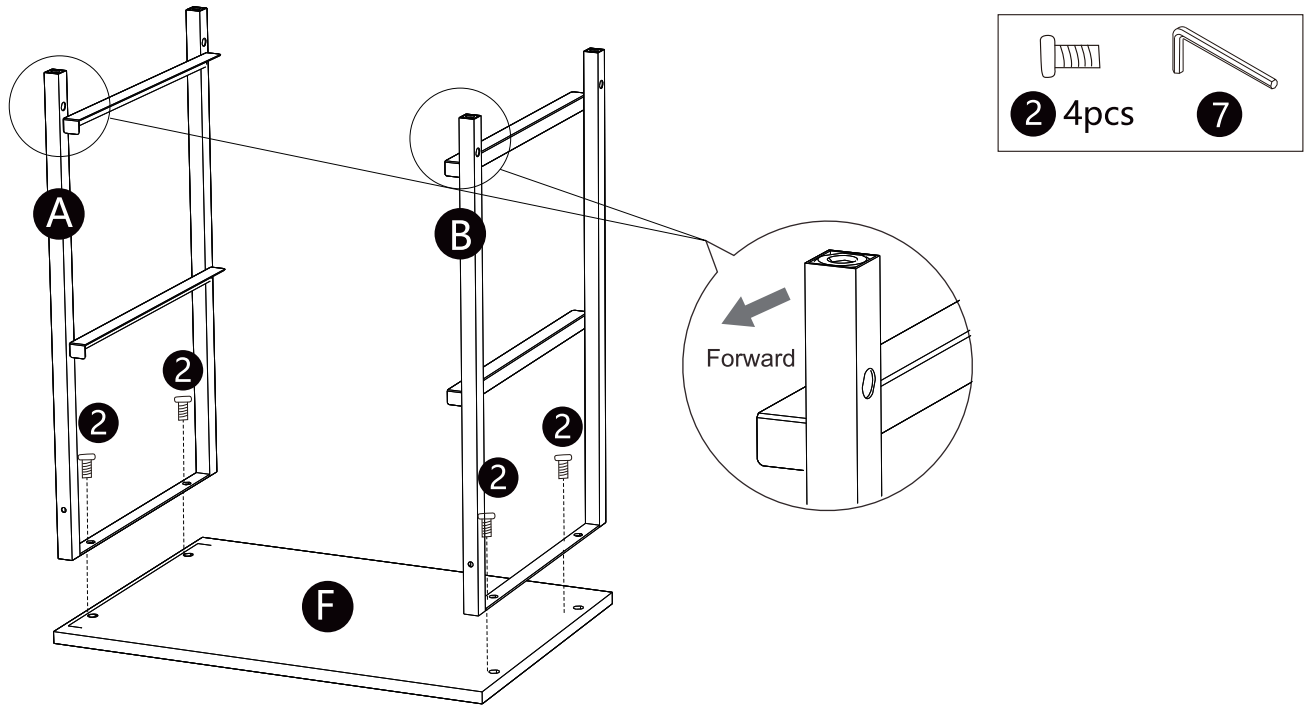

Note:

- EN 1. Place a blanket under the top plate to avoid scratches or damage.
- 2. The side frame (A & B) baffle faces in the same direction, with the baffle facing toward.

Hinweise:

- DE 1. Legen Sie eine Decke unter die obere Platte, um Kratzer oder Beschädigungen zu vermeiden.
- 2. Die Seitenrahmen (A & B) müssen in die gleiche Richtung zeigen, mit dem Ende der Schubladenblende nach vorne.

Remarques:

- FR 1. Placez une couverture sous le plateau supérieur pour éviter les rayures ou les dommages.
- 2. Les cadres latéraux (A & B) doivent être orientés dans la même direction, avec la barrière tournée vers l'avant.

Step 2

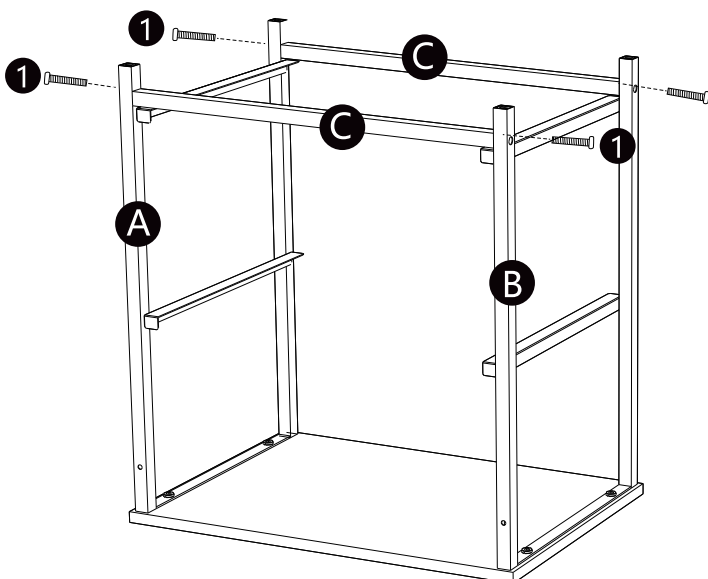
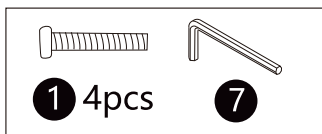

Step 3

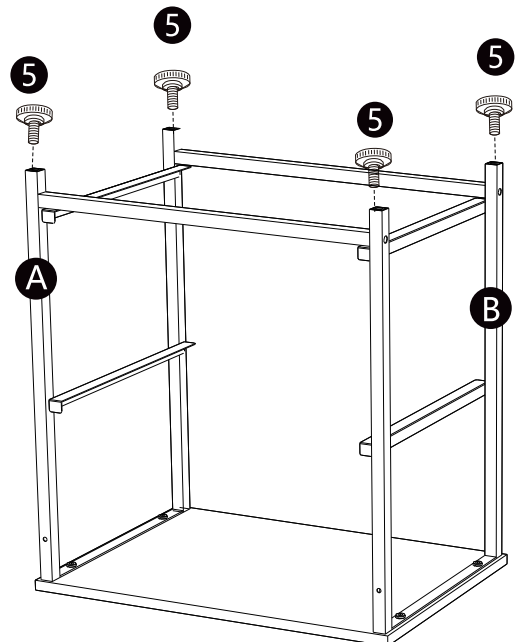
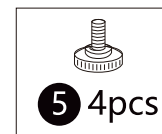

Step 4

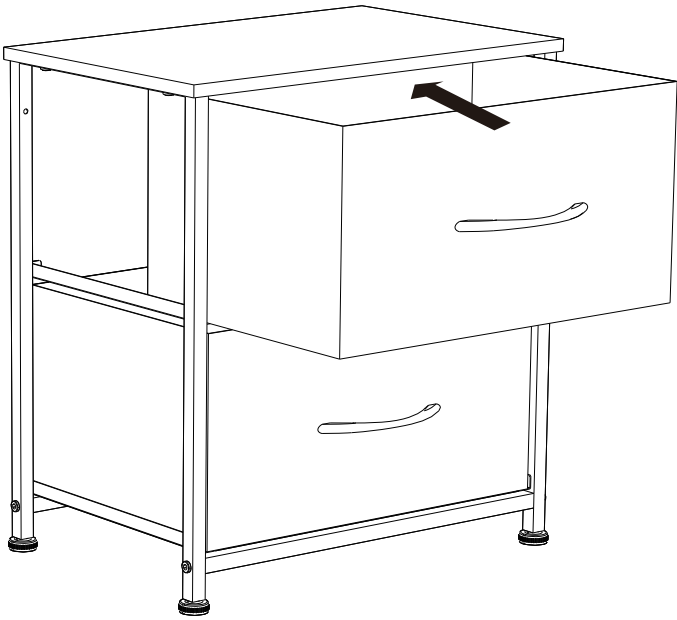
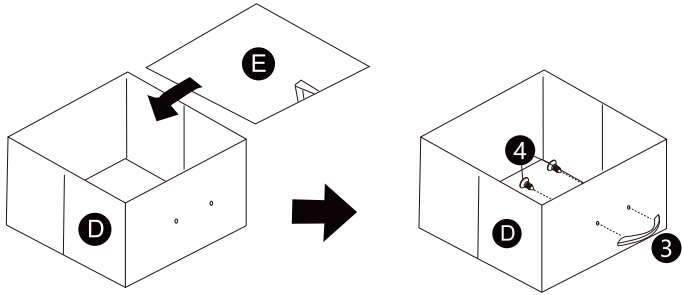
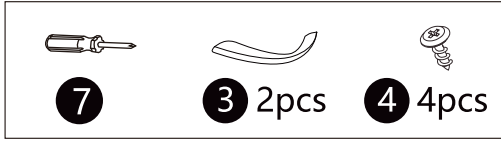

Step 5

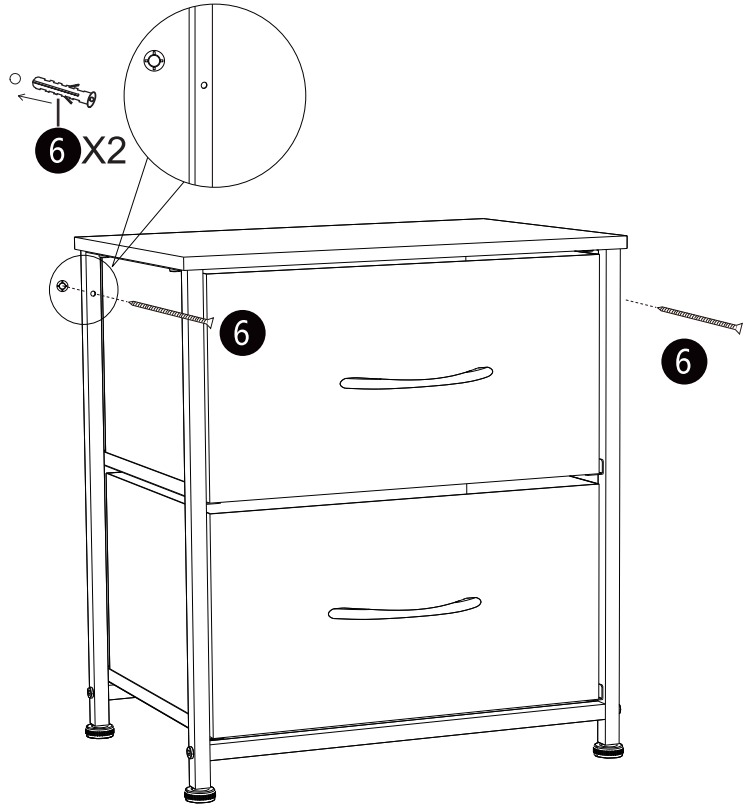
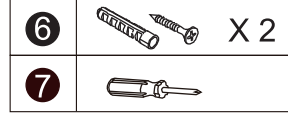

Step 6





EN **Safety Information:** Use indoors only. Ensure the cabinet is placed on a stable surface to prevent tipping. Warning: Risk of tipping if not secured. Install anti-tip devices if provided. Not suitable for children under 12 years.



DE **Sicherheitsinformationen:** Nur für den Innenbereich geeignet. Stellen Sie sicher, dass der Schrank auf einer stabilen Oberfläche steht, um ein Umkippen zu vermeiden.
Warnung: Kippgefahr, wenn nicht gesichert. Befestigen Sie Anti-Kipp-Vorrichtungen, falls vorhanden. Nicht geeignet für Kinder unter 12 Jahren.



FR **Informations de sécurité:** À usage intérieur uniquement. Assurez-vous que l'armoire est placée sur une surface stable pour éviter le basculement.
Avertissement: Risque de basculement si non sécurisé. Installez les dispositifs anti-basculement si fournis. Ne convient pas aux enfants de moins de 12 ans.

EN Thank you for choosing our product. We are committed to delivering the highest quality products and service in the industry. If you encounter any issues, please feel free to reach out to us. Your satisfaction is our priority.

DE Vielen Dank, dass Sie sich für unser Produkt entschieden haben. Wir sind bestrebt, Produkte und Dienstleistungen von höchster Qualität in der Branche zu liefern. Wenn Sie auf Probleme stoßen, können Sie sich gerne an uns wenden. Ihre Zufriedenheit ist unsere Priorität.

FR Merci d'avoir choisi notre produit. Nous nous engageons à fournir des produits de la plus haute qualité et un service de premier ordre dans l'industrie. Si vous rencontrez le moindre problème, n'hésitez pas à nous contacter. Votre satisfaction est notre priorité.