

Badezimmer – DETROIT 34

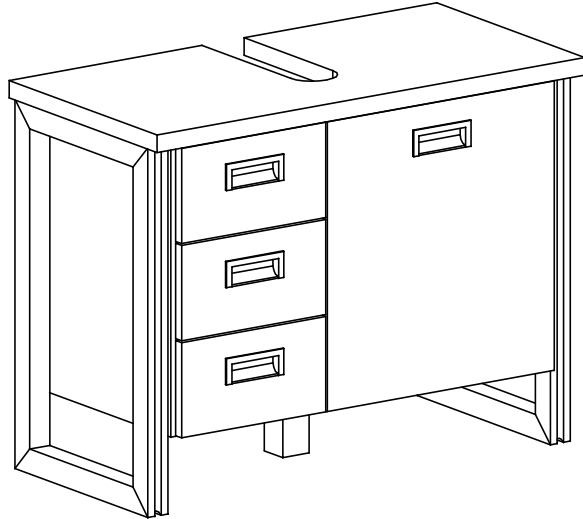

- ⓓ **Montageanleitung**
- ⓃⓁ **Handleiding voor de montage**
- ⓉⓇ **Montaj talimatı**
- ⓕ **Notice de montage**
- ⒸⓏ **Montážní návod**
- ⓗⓤ **Szerelési útmutató**
- ⓖⓔ **Assembly instructions**
- Ⓟ **Instrukcja montażu**
- Ⓡⓤ **Инструкция по монтажу**
- Ⓜ **Istruzioni di montaggio**
- ⓈⓀ **Návod na montáž**
- Ⓡⓞ **Instrucțiuni de montaj**

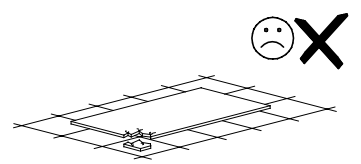

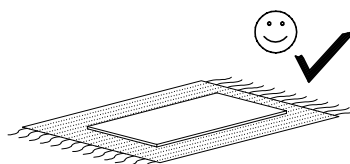
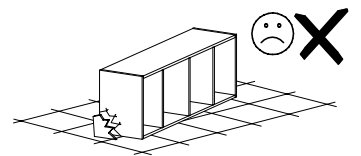
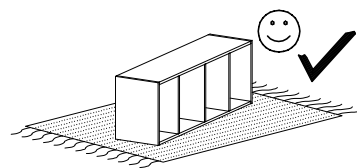
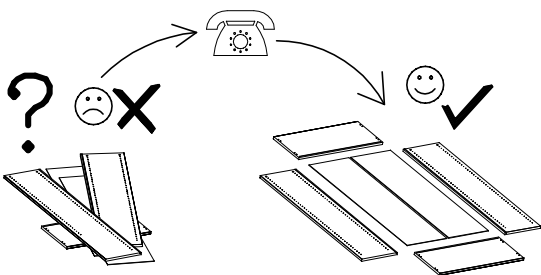
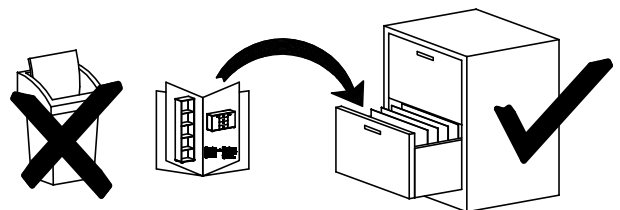
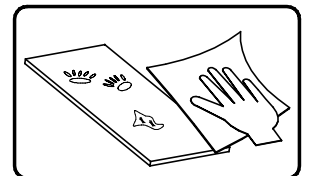
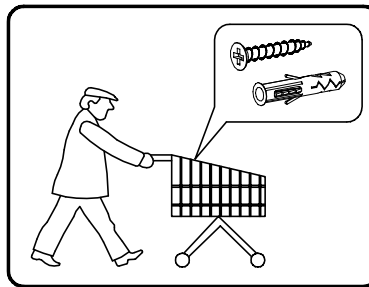
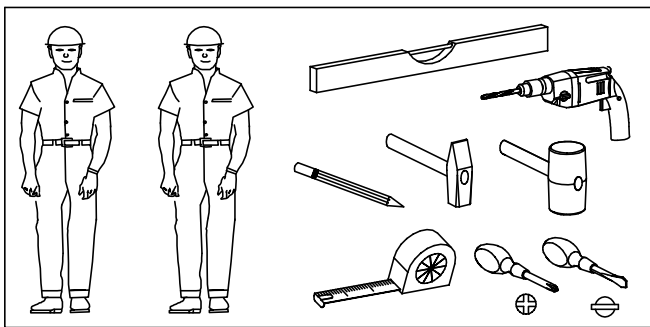
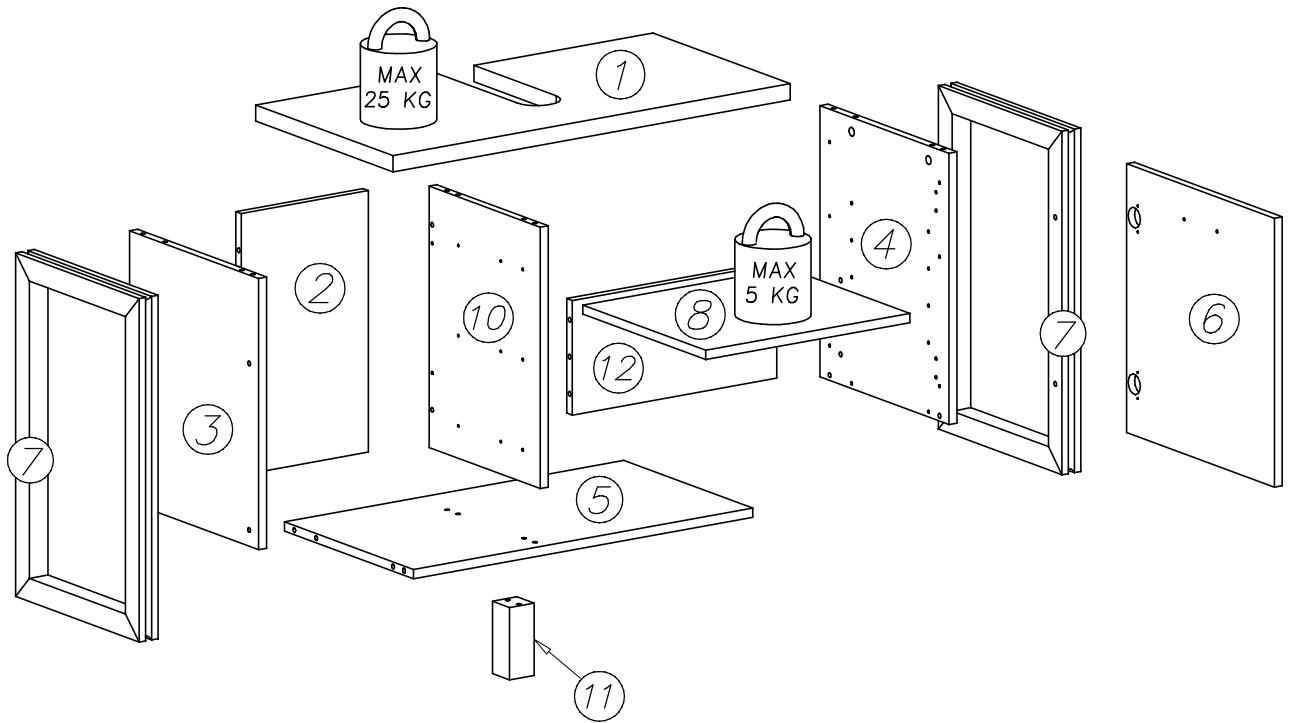
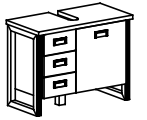

nr	L[mm]	B[mm]	T[mm]	Menge	Colli
1	810	400	28	1	1/1
2	452	259	16	1	1/1
3	469	376	16	1	1/1
4	469	376	16	1	1/1
5	692	375	16	1	1/1
6	465	430	16	1	1/1
7	594	360	38	2	1/1
8	417	302	16	1	1/1
10	452	324	16	1	1/1
11	125	50	50	1	1/1
12	417	198	16	1	1/1
13	219	300	3	3	1/1
14	273	153	16	3	1/1
15	300	100	12	3	1/1
16	300	100	12	3	1/1
17	209	100	12	3	1/1

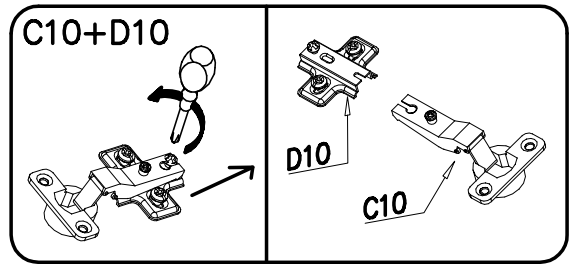
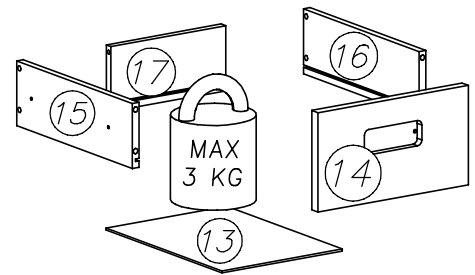
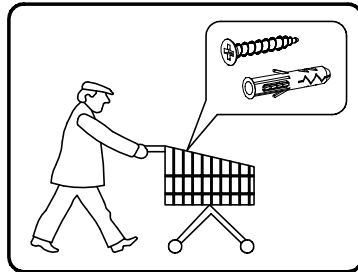

A1 ø7x50 x2	G8 4x30 x12	W1 GLUE, LEIM, LEPIDLO, LIM x2	E73 96mm x4	C10+D10
G20 5x13 x30	G22 3,5x16 x8	F3 x4	P4 x5	Z35PL x2
K1 ø15x12 x16	K10 x16	H23 H35-300mm x3	M11 x1	G34 3,5x16 x6
W2 x1	B1 ø8x35 x30		I8 ø20 x16	A6 ø7x40 x12

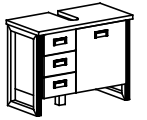

I

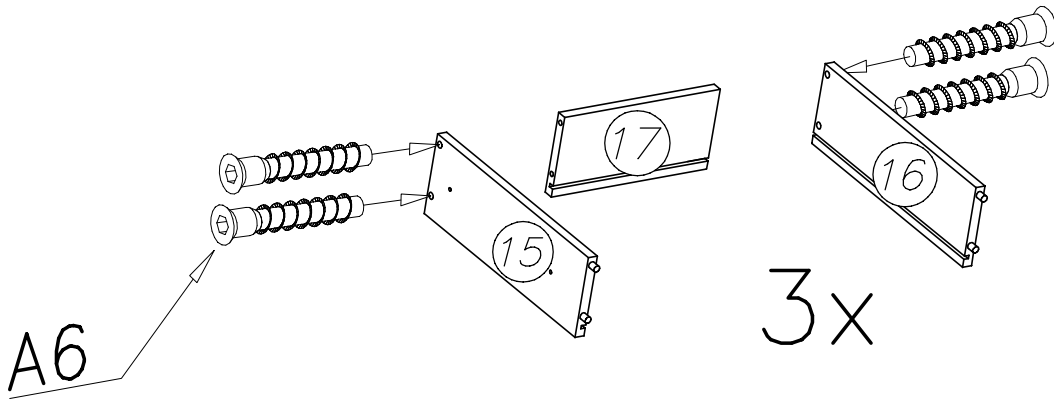
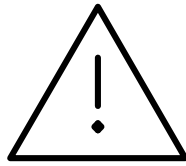

W1		x1
A6		x12
E73		x3
96mm		
W2		x1
G22		x6
3,5x16		

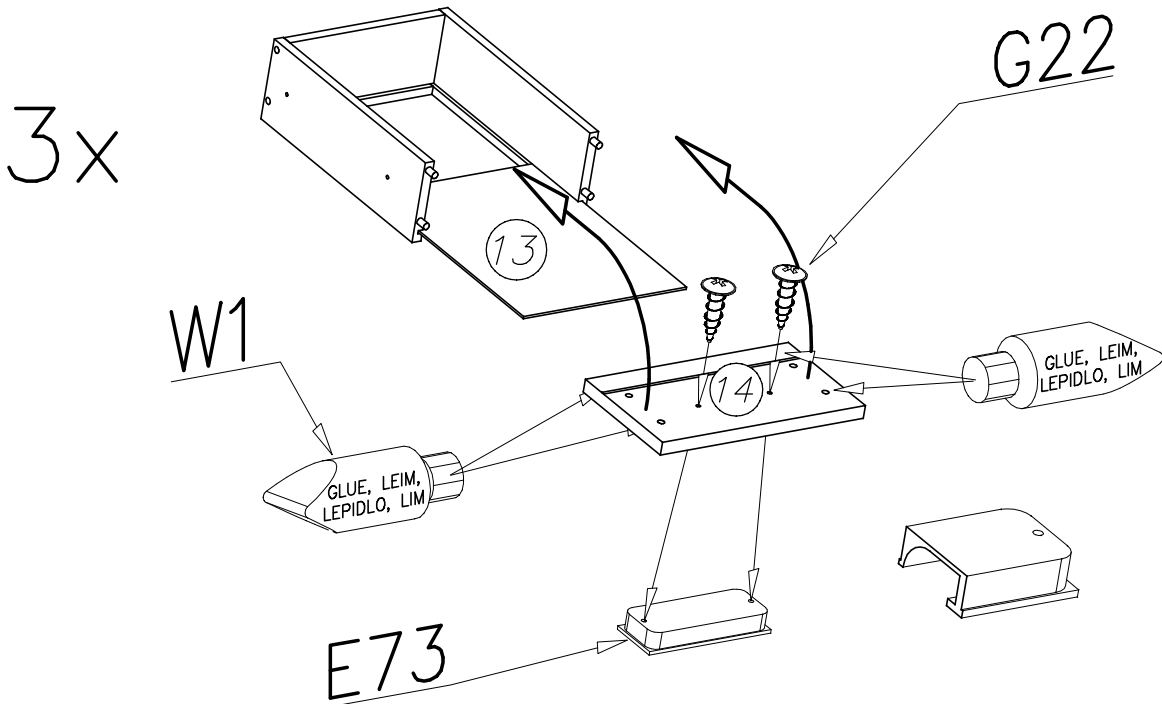

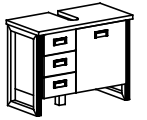

(A)

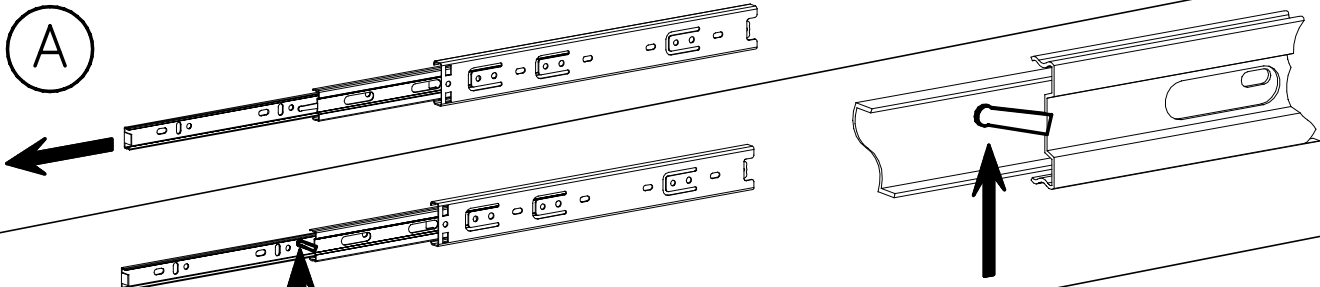

(B)

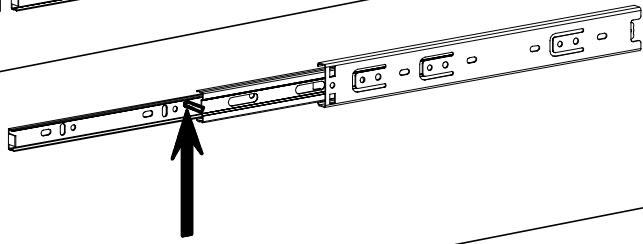

(C)

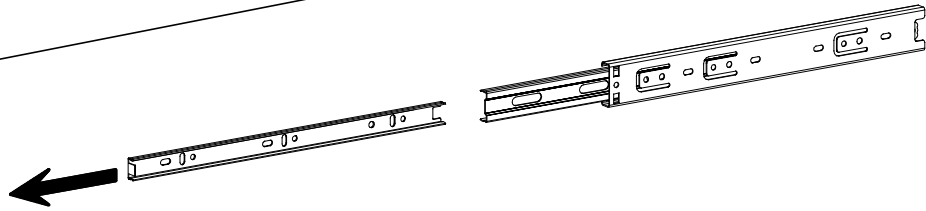

II

G20 
5x13 x12

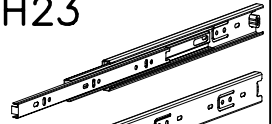
H23 
H35-300mm x3

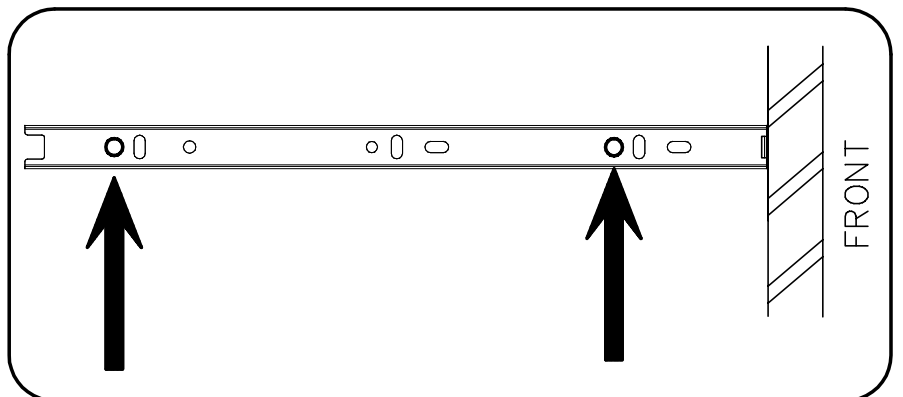
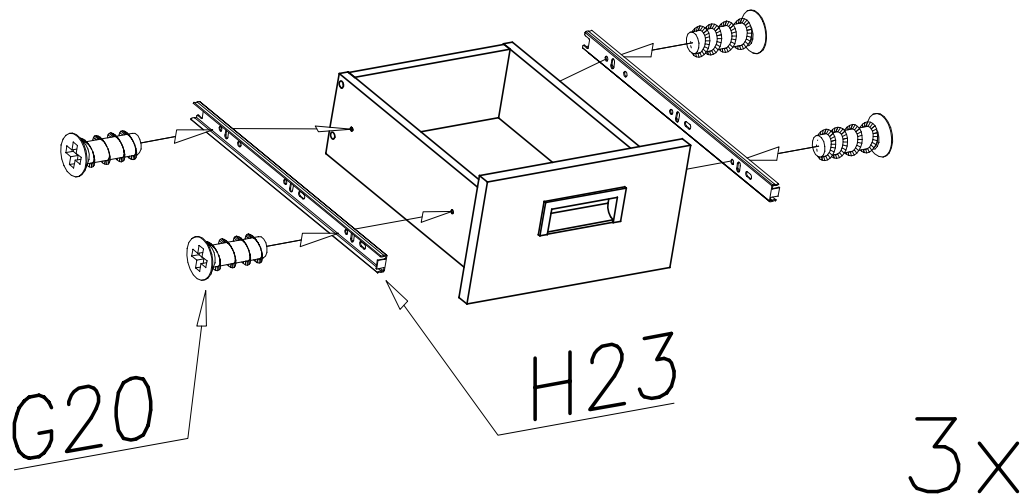

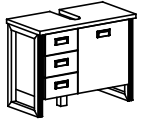

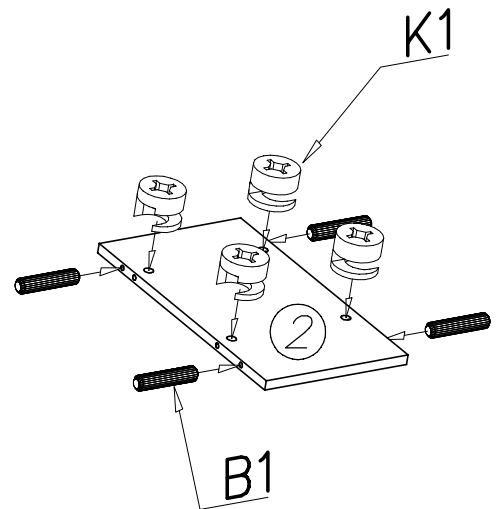
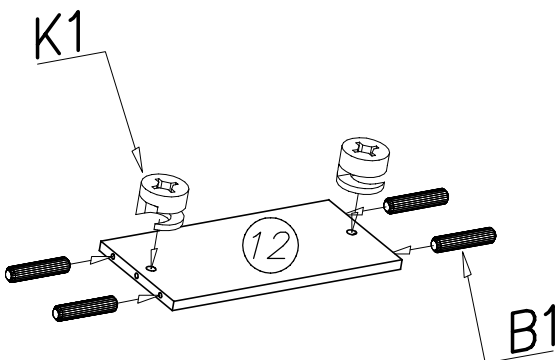
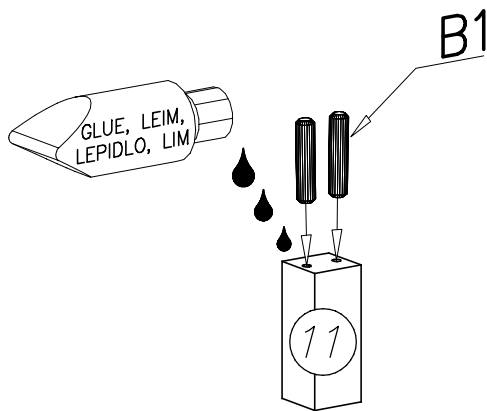
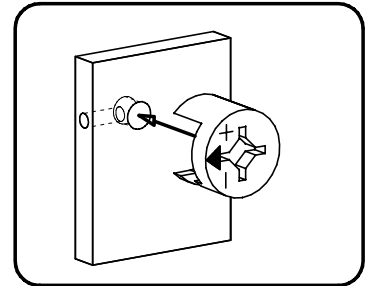
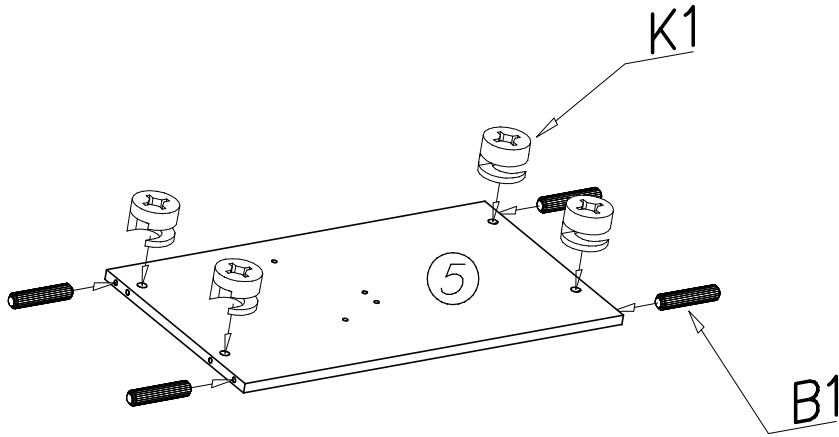
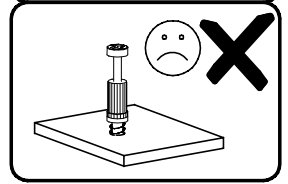
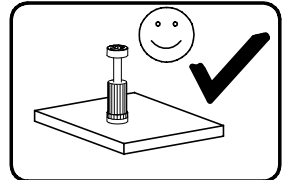
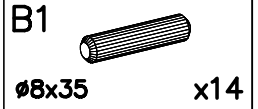
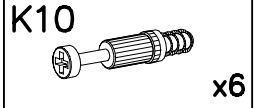
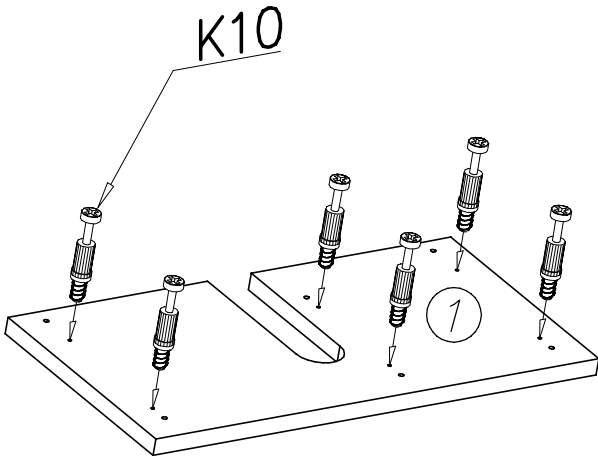

III

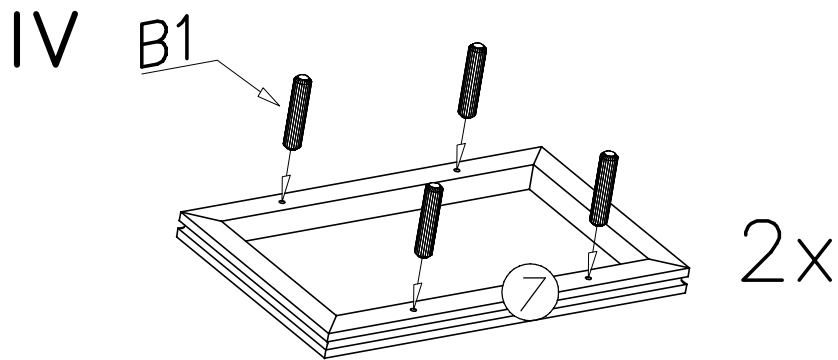
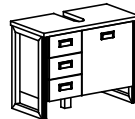

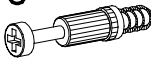
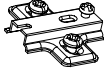

K10  x10	D10  x2
B1  ∅8x35 x16	K1  ∅15x12 x8

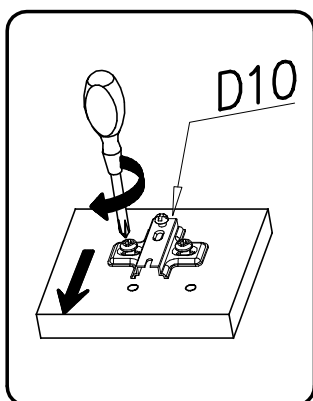
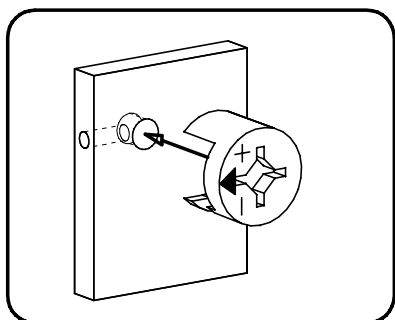
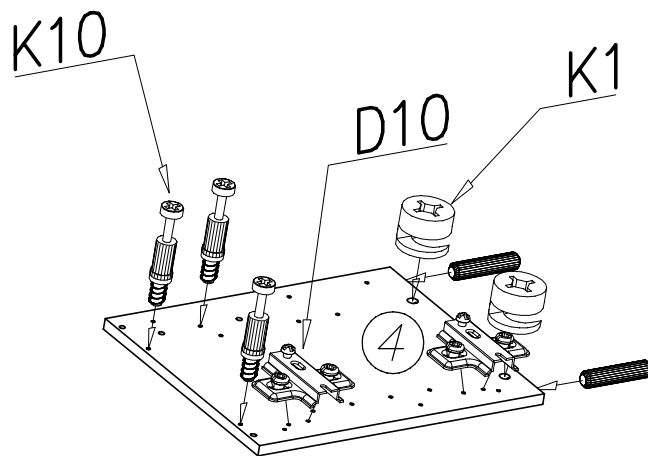
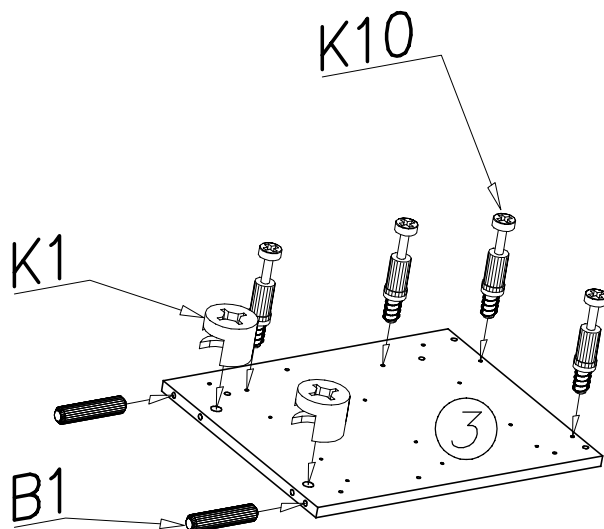
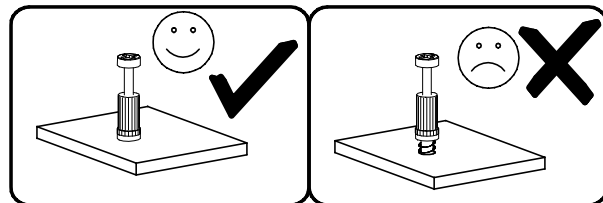
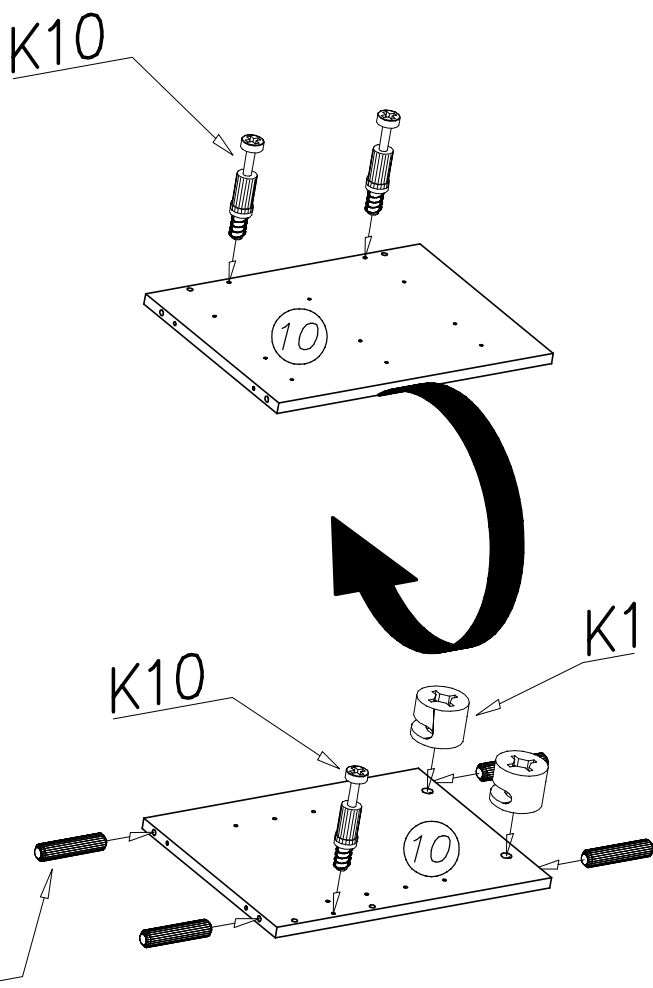

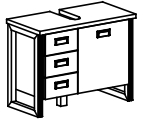

V

G20 
5x13

x18

H23 
H35-300mm **x3**

G20

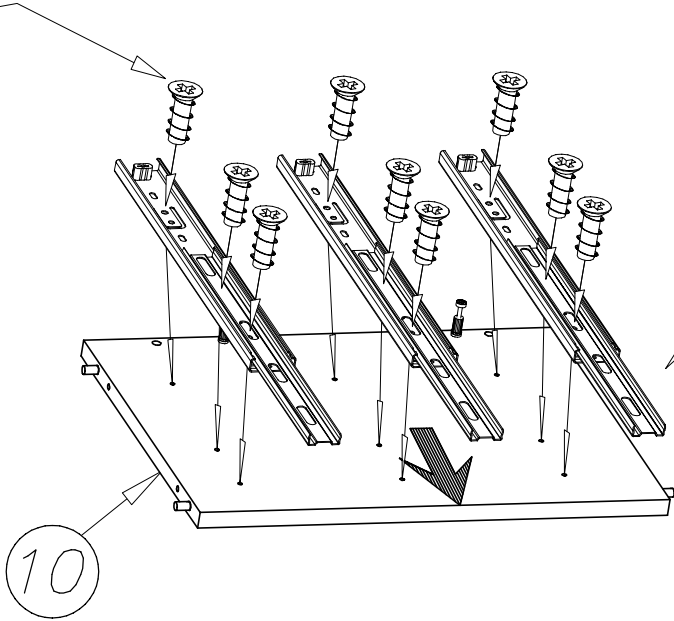

H23

G20

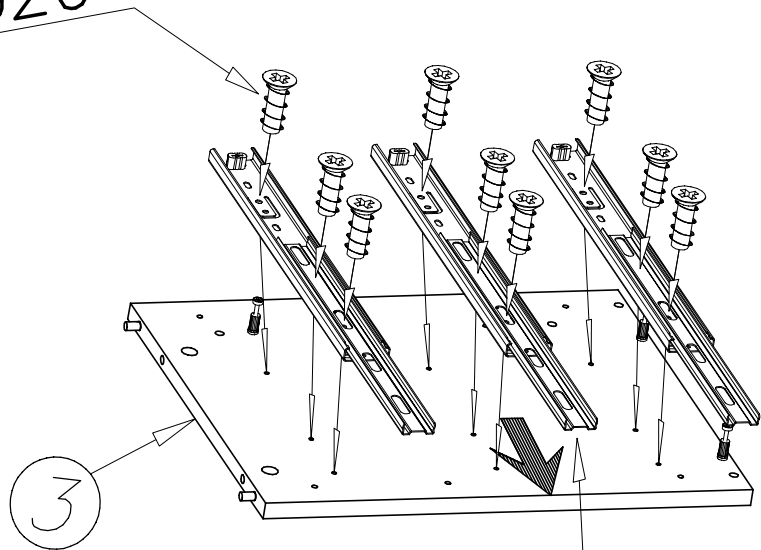

H23

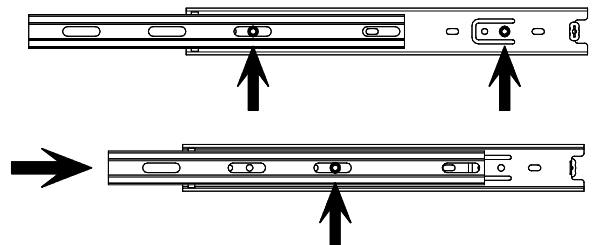
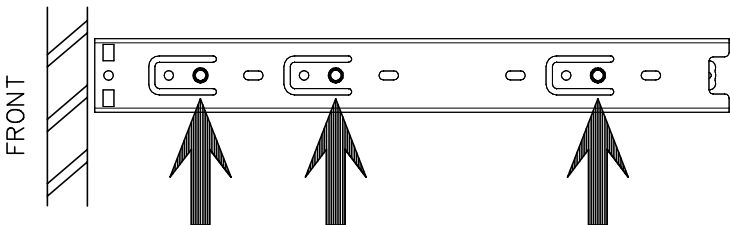

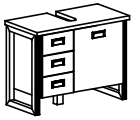

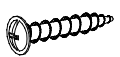

VI

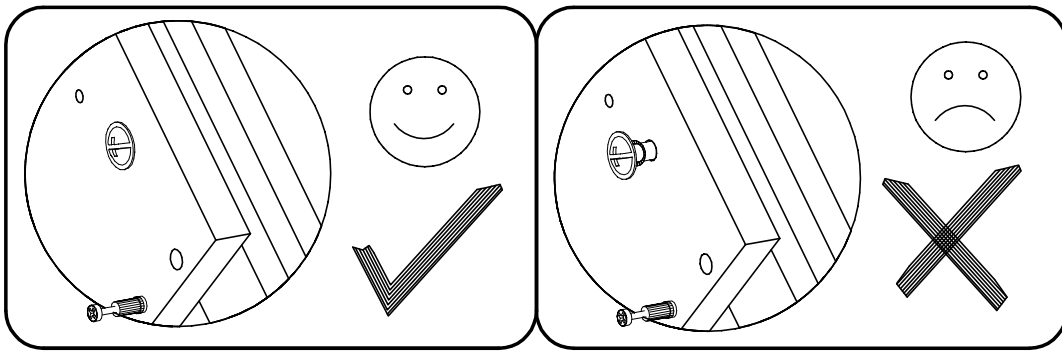
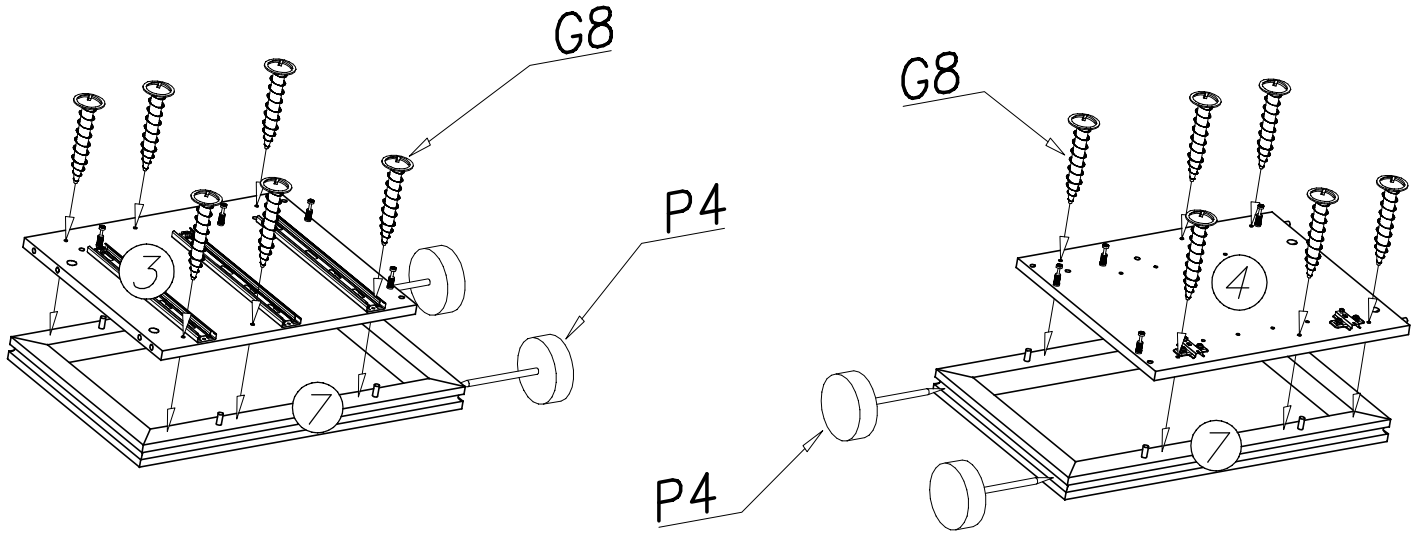
P4		x4	G8		x12
			4x30		

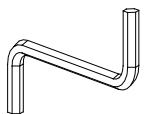

VII

W2		x1	A1		x2
			ø7x50		

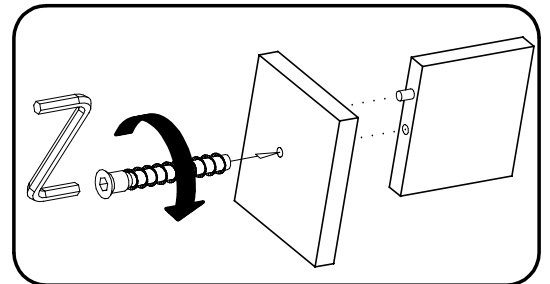
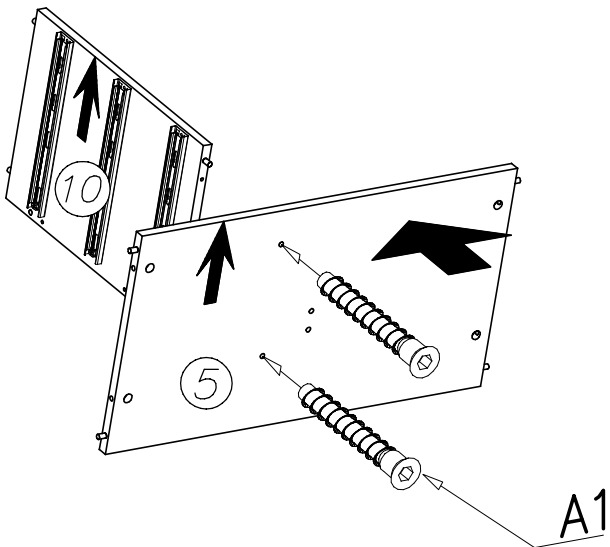

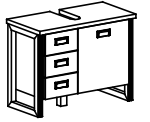

VIII

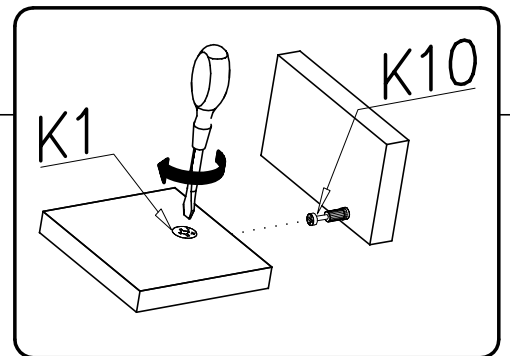
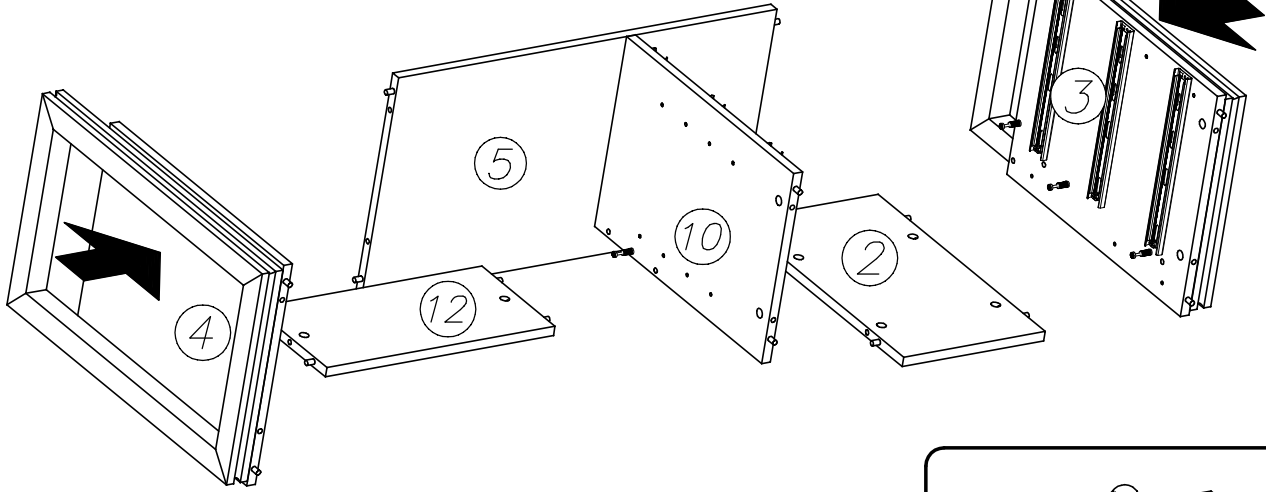

IX

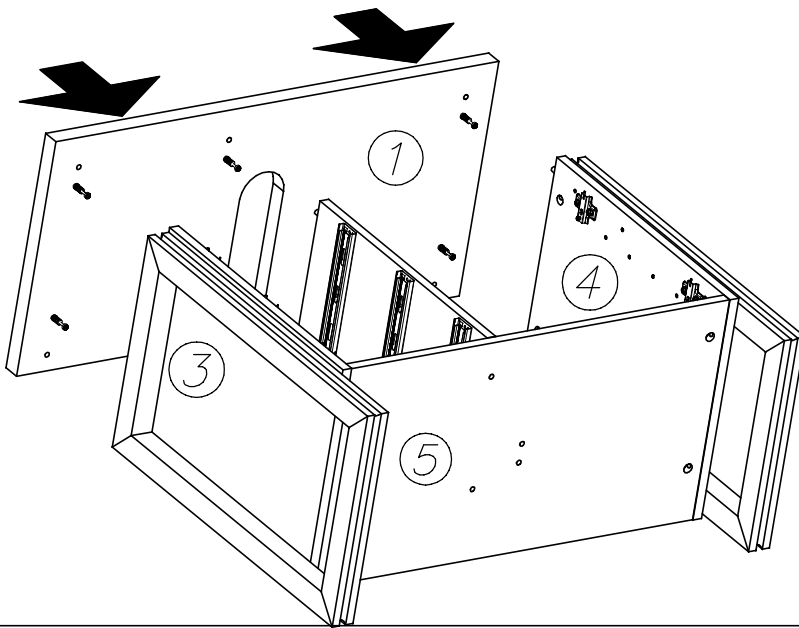

X

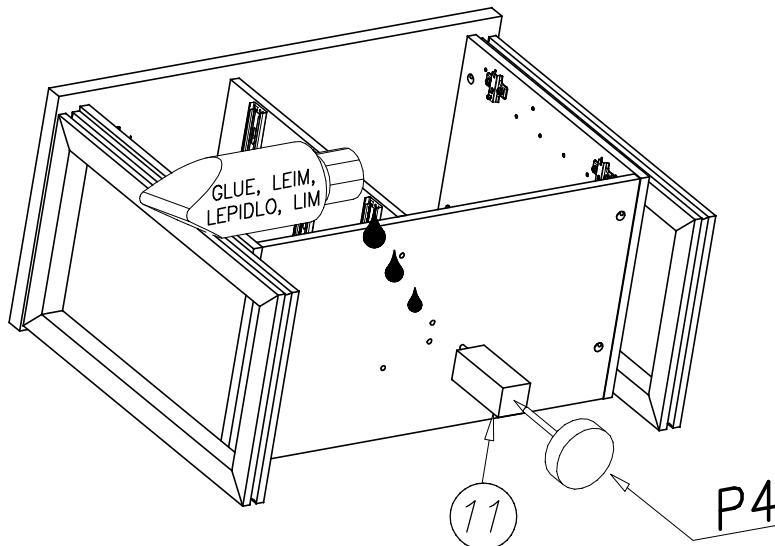



x1

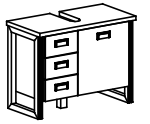

x1



XI

- 18  x18
- F3  x4



1

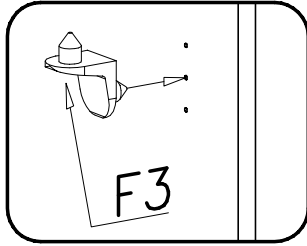

2

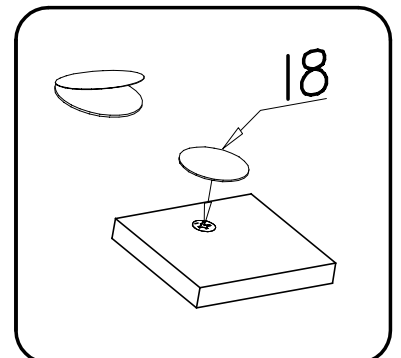
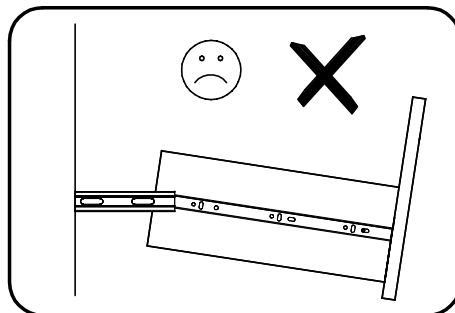
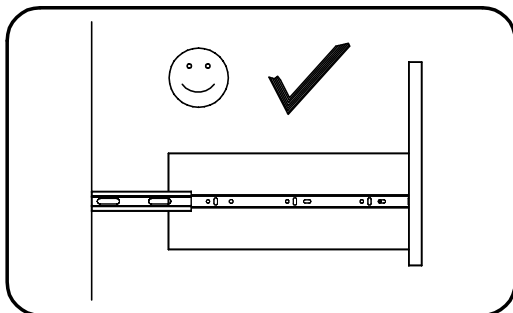
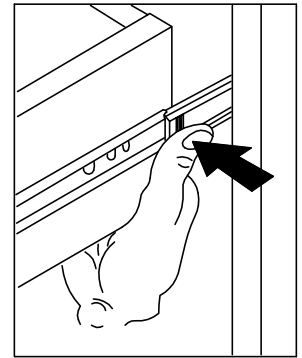
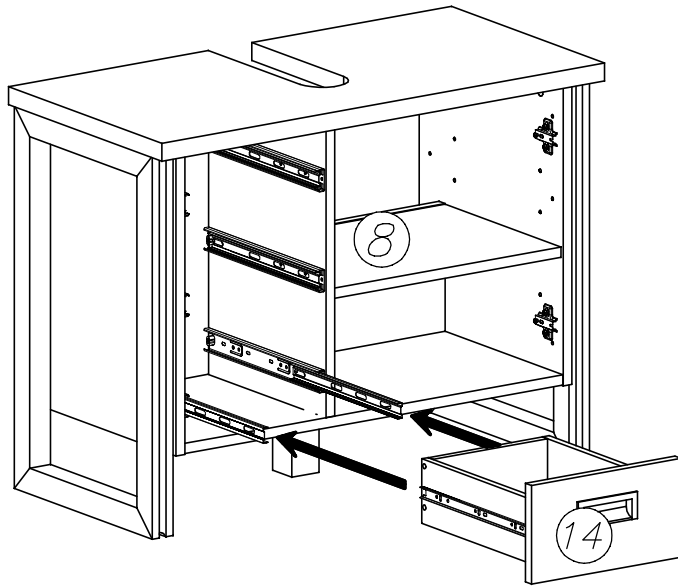
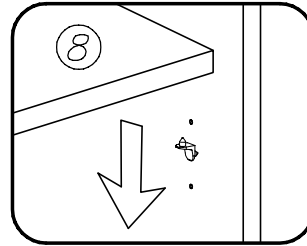

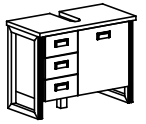

G34 

3,5x16 x2

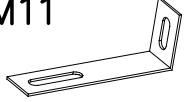
M11  x1

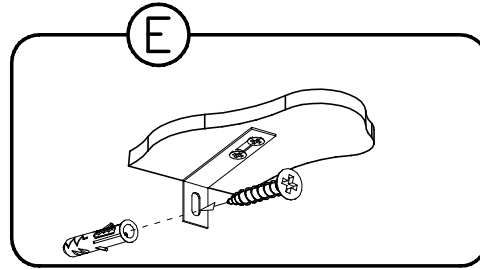
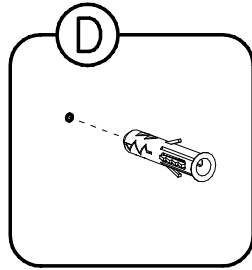
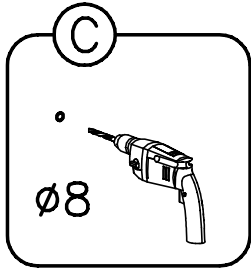
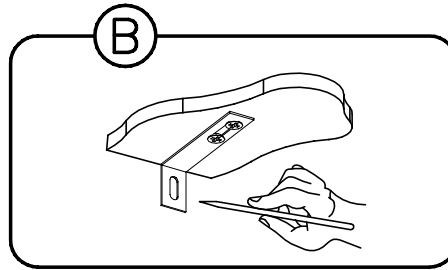
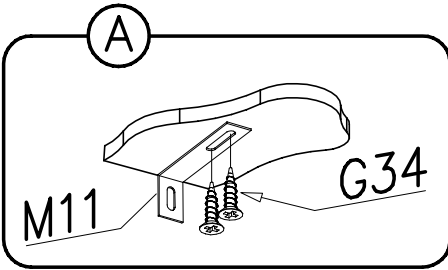

XII

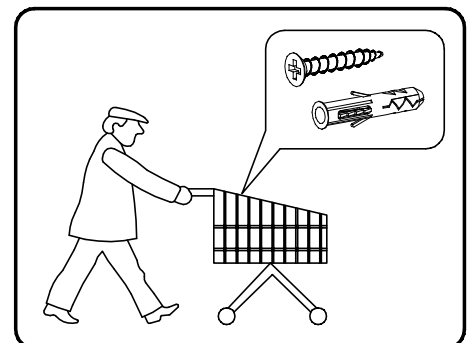
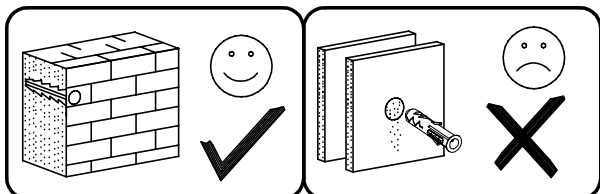
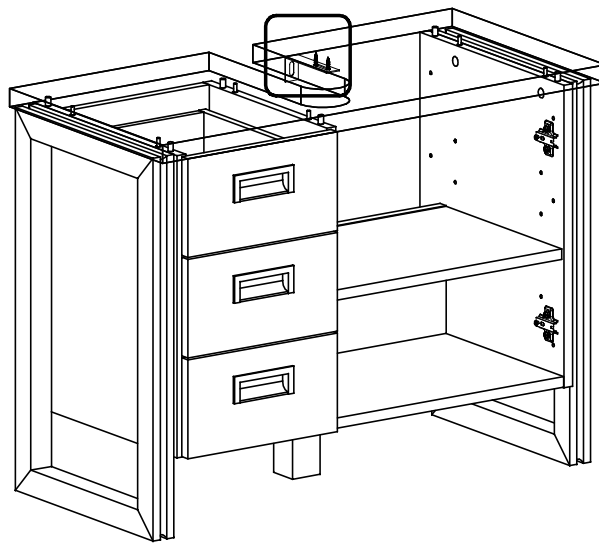

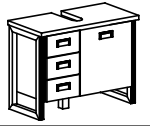

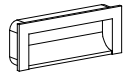

XIII

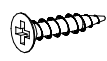
E73  x1
96mm

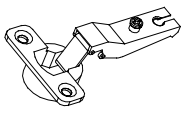
G34  x4
3,5x16

C10  x2
Z35PL

G22  x2
3,5x16

Z35PL x2

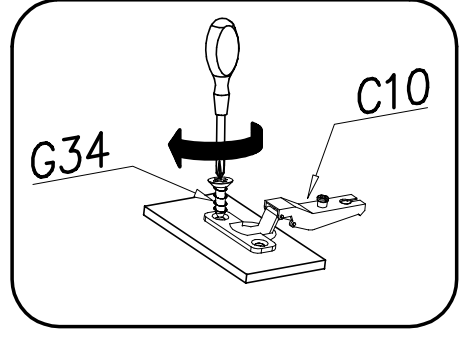
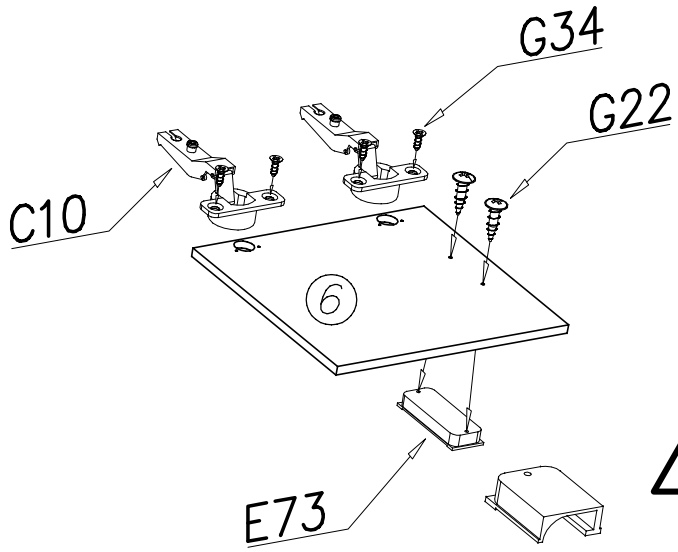

XIV

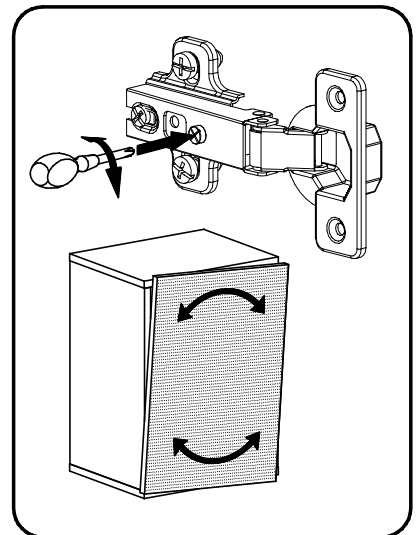
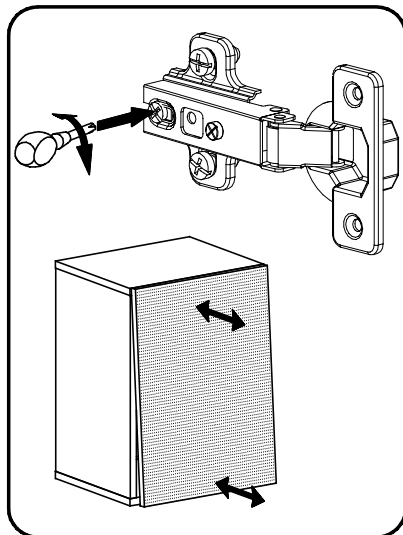
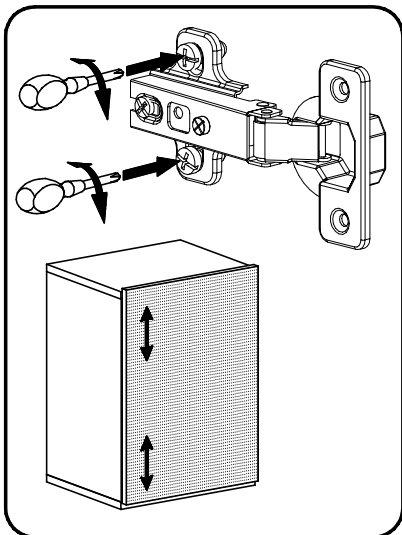
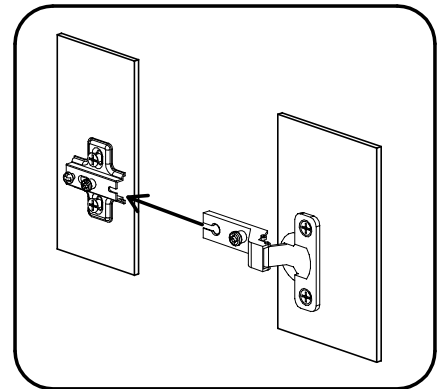
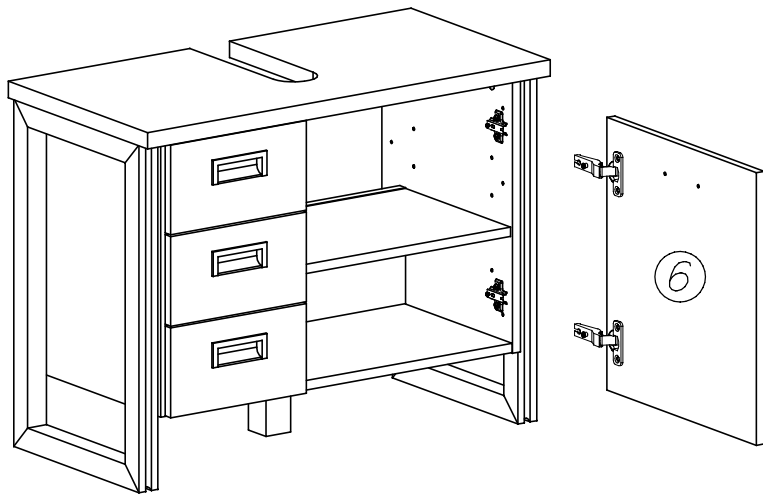



XV

R7
610mm x1

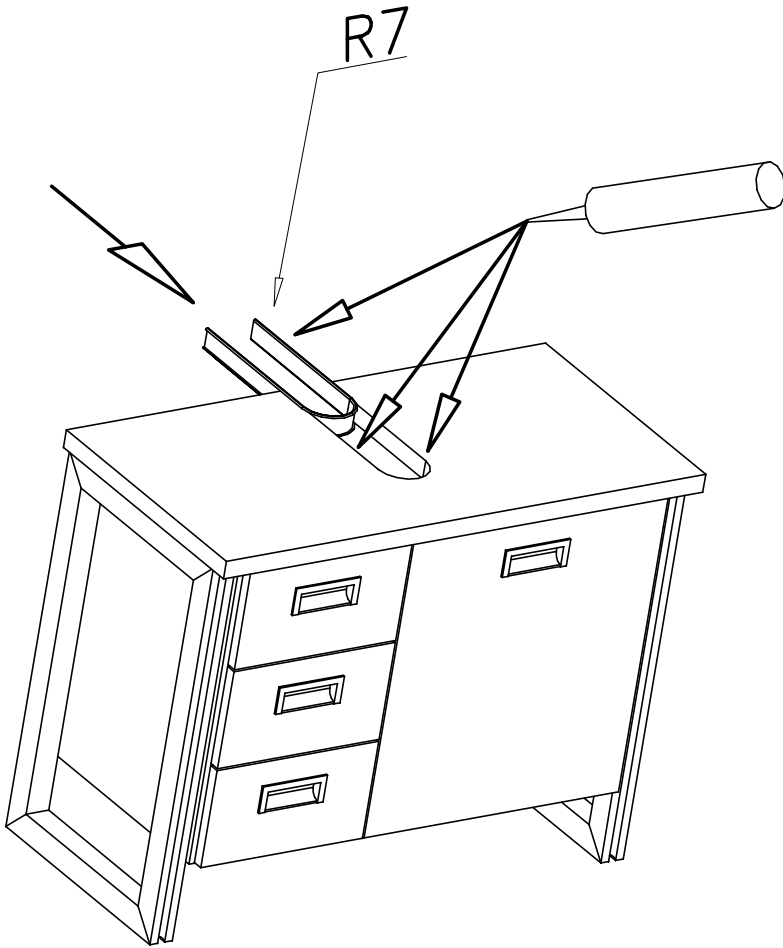
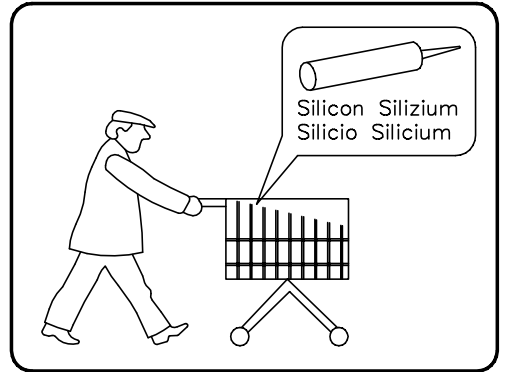

XVI

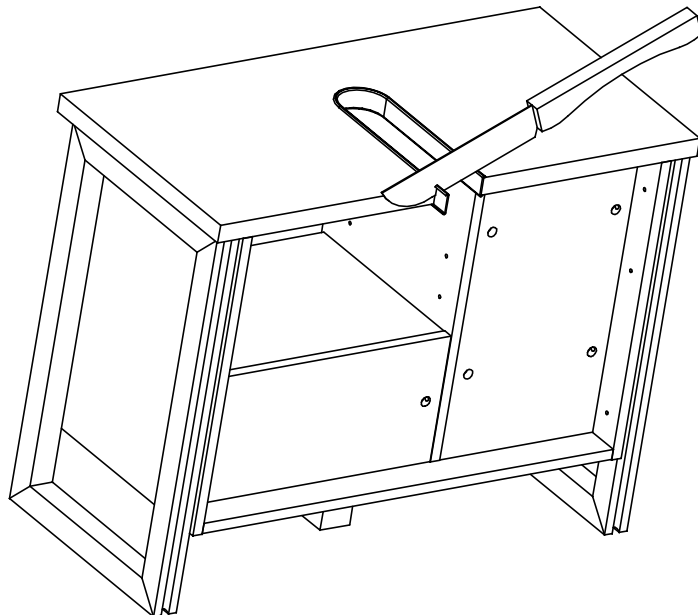

Name • Nom • Nome • Naam • Nazwa • Имяно
• Názov • Név • Denumire • Isim • Извание

Nr • No • N° • Номер • Č • Sz

Typ • Type • Tip • Típus • Tipo • Tun

Badezimmer—DETROIT

— —

34

D

Unser Direktservice für Beschlagteile
Sollte Ihnen ein Beschlagteil fehlen, können Sie diese Servicekarte direkt an die untenstehende Nummer senden. Wir können allerdings nur Beschlagteile auf diesem Weg verschicken. Sollen Sie eine andere Beanstandung an Ihrem Möbelstück haben, so wenden Sie sich bitte direkt an Ihr Möbelhaus.

GB

Our direct order service for fitting
If a fitting should be missing to you, you know this service map directly following number faxes. We can in this way send away however only fitting. If you should have another objection to your piece of furniture, then they turn please to your furniture house.

CZ

Naše přímé služby pro kování
Chybí-li vám nějaký díl z kování, můžete tuto servisní kartu odfaxovat přímo na níže uvedené číslo. Touto cestou však můžeme zoslat jen díly kování. Pokud byste reklamovali jiný díl nábytku, obraťte se přímo na svého prodejce nábytku.

F

Bien étudier la notice de montage
Repérez les pièces constituant votre meuble. Regroupez et contrôlez la quincaillerie. Munissez - vous de l'outillage nécessaire. Aménagez - vous une zone de montage. Procédez au montage. Ne jamais forcer les assemblages. Resserrez les vis après quelques temps d'usage. Garder votre notice de montage, si une pièce venait à manquer, elle serait le plus clair moyen de communiquer avec votre magasin.

I

Il nostro servizio diretto per l'ordine della ferramenta
Nel caso vi mancassero dei pezzi, potete spedire fax questa carta die servizi direttamente al seguente numero. Per altri reclami al vostro mobile, potete rivolgervi al vostro mobilificio.

BG

Директно обслужаване на електрични делци "Обнова"
Ако ви недостига некои делци за електрично монтажа, можете директно да испратите овај сервисни карт на следниот број на факс. Можеме на тој начин да ви доставиме само делци за електрично монтажа. Ако имате друга претензија на вашиот мебел, молиме да се обратите директно на вашиот продавач на мебел.

NL

Onze directservice voor loose onderdelen
Wanneer er een onderdeel mist kunt u deze servicekaart direct aan onderstaand faxnummer sturen. Wij kunnen alleen langs deze weg onderdelen versturen. Mocht u een ander probleem aan uw meubel hebben verzoeken wij u contact op te nemen met uw meubeldealer.

PL

Nasz bezpośredni serwis części montażowych
Jeżeli brakuje części koniecznych do montażu, prosimy o przesłanie nam tej karty serwisowej na niżej podany numer faxu. Możemy w ten sposób przysłać partiami tylko brakujące części. W przypadku innych obiekcyj dotyczących mebla, prosimy o zgłoszenie ich do salonu meblowego w którym został dokonany zakup.

HR

Servis za okove
U slučaju da nedostaje neki od dijelova molimo vas da na dolje navedeni Fax broj posaljete ovaj servisni obrazac. Na ovaj način mogu se dostaviti samo okovi. U slučaju da imate dodatne prigovore vezane uz komad namještaja molimo vas da se obratite izravno trgovini namještaja gdje je isti kupljen.

HU

Direktszoigélatunk veseletoik esztén
Ha hiányzik egy veselet, ezt a kártyát közzvetlenül elfaxolhatja az alább található faxszámra. Azonban csakis veseletoikat tudunk így köldeni. Amennyiben másfajta reklamáció áll fenn bútordarabjait illetően, forduljon közzvetlenül a bútornázhoz.

SK

Náš priamy servis pre časti kovania
Ak by Vám chýbala nejaká časť kovania, môžete poslať túto servisnú kartu priamo faxom priamo na nižšie uvedené faxové číslo. Diely kovania vieme poslať iba týmto spôsobom. Ak by ste mali inú reklamáciu ohľadom vášho nábytku, obráťte sa priamo na Vašu predajnú nábytku.

SLO

Naše direktne službe storitve za okovje
Ce vam manjka kakšno okovje, lahko to servisno kartico pošljete po faksu direktno na spodnjo številko. Po tej poti vam lahko pošljemo samo okovje. Če želite reklamirati kakšen drug del pohištva, se obrnite neposredno na vašo trgovino pohištva.

RO

Service-ul nostru direct pentru feronerie
In cazul in care va lipsesc o piesa de feronerie puteti sa trimitezi direct acest card de service pe fax la numarul de mai jos. Noi nu putem expedia piese de feronerie decât pe această cale. Dacă aveți o altă reclamație referitoare la piese de mobilier, atunci vă rugăm să vă adresați direct la magazinul dvs. de mobilă.

RUS

Наш прямой сервис для поставок фурнитуры
Если ожидается, что Вам не хватает того или иного элемента фурнитуры, Вы можете отправить сервисную карту по факсу непосредственно на нижеприведенный номер. Однако, таким образом мы можем переслать лишь фурнитуру. Если же у Вас возникнут иные претензии относительно приобретенной мебели, пожалуйста, обращайтесь непосредственно в организацию, осуществлявшую продажу.

S

Vår direktservice för beslagdelar
Om du saknar en beslagdel kan du faxa detta servicekort direkt till numret som anges ned. Tänk på att detta är den enda möjligheten att skicka beslagdelar till dig. Om du vill reklamera din möbel av en annan anledning måste du kontakta ditt möbelhus direkt.

ES

Nuestro servicio directo para accesorios
Si le falta algún accesorio, puede enviar esta tarjeta de servicio directamente a la siguiente dirección. No obstante, por este método solo podemos enviar accesorios. Si tiene alguna otra objeción sobre su mueble, consulte directamente con su mueblería.

TR

Donatılar için doğrudan servisimiz
Bir donatınız eksikse bu servis kartını doğrudan esagida bulunan adrese doğrudan mail yazabilirsiniz. Sadece bu yolla donatılar gönderiliriz. Mobilyanızda başka şikayetleriniz varsa lütfen doğrudan mobilya satışınıza danışın.

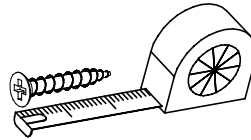

R7 610mm x...	A1 ø7x50 x...	G20 5x13 x...
G8 4x30 x...	K1 ø15x12 x...	K10 x...
G22 3,5x16 x...	W2 x...	B1 ø8x35 x...
W1 x...	E73 96mm x...	C10+D10
F3 x...	P4 x...	Z35PL x...
H23 H35—300mm x...	M11 x...	G34 3,5x16 x...
	I8 ø20 x...	A6 ø7x40 x...

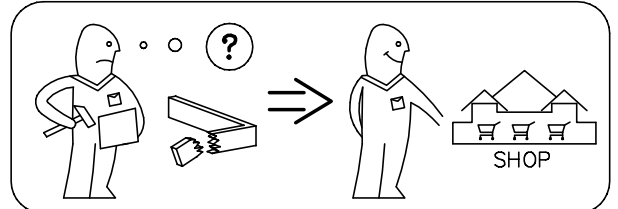
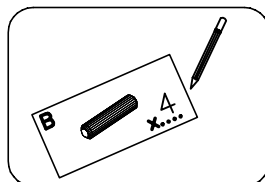

Name • Nom • Nome • Naam • Nazwa • Jméno
• Názov • Név • Denumire • Isim • Имя

Nr • No • N° • Номер • Č • Sz

Typ • Type • Tip • Típus • Tipo • Tun

Badezimmer—DETROIT

— —

34

D Unser Direktservice für Beschlagteile
Sollte Ihnen ein Beschlagteil fehlen, können Sie diese Servicekarte direkt an die untenstehende Nummer senden. Wir können allerdings nur Beschlagteile auf diesem Weg verschicken. Sollen Sie eine andere Beanstandung an Ihrem Möbelstück haben, so wenden Sie sich bitte direkt an Ihr Möbelhaus.

GB Our direct order service for fitting
If a fitting should be missing to you, you know this service map directly following number faxes. We can in this way send away however only fitting. If you should have another objection to your piece of furniture, then they turn please to your furniture house.

CZ Naše přímé služby pro kování
Chybí-li vám nějaký díl z kování, můžete tuto servisní kartu odfaxovat přímo na níže uvedené číslo. Touto cestou však můžeme rozeslat jen díly kování. Pokud byste reklamovali jiný díl nábytku, obraťte se přímo na svého prodejce nábytku.

F Bien étudier la notice de montage
Repérez les pièces constituant votre meuble. Regroupez et contrôlez la quincaillerie. Munissez - vous de l'outillage nécessaire. Aménagez - vous une zone de montage. Procédez au montage. Ne jamais forcer les assemblages. Resserrez les vis après quelques temps d'usage. Garder votre notice de montage, si une pièce venait à manquer, elle serait le plus clair moyen de communiquer avec votre magasin.

I Il nostro servizio diretto per l'ordine della ferramenta
Nel caso vi mancassero dei pezzi, potete spedire fax questa carta di servizi direttamente al seguente numero. Per altri reclami al vostro mobile, potete rivolgervi al vostro mobilificio.

BG Добро ето обслуужба на електрични "Оборат"
Реко ладна е чинија или електрични, доставителите ниту или ладна е електрични не бидателни не бидателни - нојат, дојачин до-долу. До кога нечии електрични дојачин е ладна електрични ладна електрични об-оборат. Реко улич-нојачин дојачин дојачин електрични, електрични дојачин електрични електрични, об-оборат или електрични дојачин.

NL Onze directservice voor losse onderdelen
Wanneer er een onderdeel mist kunt u deze servicekaart direct aan onderstaand faxnummer sturen. Wij kunnen alleen langs deze weg onderdelen versuren. Mocht u een ander probleem aan uw meubel hebben verzoeken wij u contact op te nemen met uw meubeldealer.

PL Nasz bezpośredni serwis części montażowych
Jeżeli brakuje części koniecznych do montażu, prosimy o przesłanie nam tej karty serwisowej na niżej podany numer faxu. Możemy w ten sposób przysłać państwu tylko brakujące części. W przypadku innych objętości dotyczących mebla, prosimy o zgłoszenie ich do salonu meblowego w którym został dokonany zakup.

HR Servis za okove
U slučaju da nedostaje neki od dijelova molimo vas da na dole navedeni Fax broj pošaljete ovaj servisni obrazac. Na ovaj način mogu se dostaviti samo okovi. U slučaju da imate dodatne prigovore vezane uz komad namještaja molimo vas da se obratite izravno trgovini namještaja gdje je isti kupljen.

HU Direktszolgálatunk veszelatok esetén
Ha hiányzik egy veszelat, ezt a kártyát közvetlenül elfaxolhatja az alább található faxszámra. Azonban csak veszelatokat tudunk így küldeni. Amennyiben másféle reklamáció áll fenn bútorárbaját illetően, forduljon közvetlenül a bútorháznál.

SK Náš priamy servis pre badi kovania
Ak by Vám chýbala nejaká časť kovania, môžete poslat túto servisnú kartu poslat faxom priamo na nižšie uvedené faxové číslo. Diely kovania vieme poslať iba týmto spôsobom. Ak by ste mali inú reklamáciu ohľadom Vášho nábytku, obraťte sa priamo na Vašu predajnu nábytku.

SLO Naše direktno služne storitve za okovje
Ce vam manjka kakšno okovje, lahko to servisno kartico pošljete po faksu direktno na spodnjo številko. Po tej poti vam lahko pošljemo samo okovje. Če želite reklamirati kakšen drug del pohištva, se obrnite neposredno na vašo trgovino pohištva.

RO Service-ul nostru direct pentru feronerie
In cazul in care va lipseste o piesa de feronerie puteti sa trimitezi direct acest card de service pe fax la numarul de mai jos. Noi nu putem expedia piese de feronerie decat pe acestasi cale. Dacai avezi o alta reclamatie referitoare la piesa de mobilier, atunci va rugam sa va adresati direct la magazinul dvs. de mobilier.

RUS Наш прямой сервис для поставок фурнитуры
Если окажется, что Вам не хватает того или иного элемента Фурнитуры, Вы можете отправить сервисную карту по Факсу непосредственно на нижеприведенный номер. Однако, таким образом мы можем пересылать лишь Фурнитуру. Если же у Вас возникнут иные претензии относительно приобретенной мебели, пожалуйста, обращайтесь непосредственно в организацию, осуществляющую продажу.

S Vår directservice för beslagsdelar
Om du saknar en beslagsdel kan du faxa detta servicekort direkt till numret som anges ned. Tänk på att detta är den enda möjligheten att sicka beslagsdelar till dig. Om du vill reklamera din möbel av en annan anledning måste du kontakta ditt möbelhus direkt.

ES Nuestro servicio directo para accesorios
Si le falta algún accesorio, puede enviar esta tarjeta de servicio directamente a la siguiente dirección. No obstante, por este método solo podemos enviar accesorios. Si tiene alguna otra objeción sobre su mueble, consulte directamente con su mueblería.

TR Donatılar için doğrudan servisimiz
Bir donatınız eksikse bu servis kartını doğrudan aşağıda bulunan adrese doğrudan mail yazabılırsınız. Sadece bu yolla donatılar gönderilebilir. Mobilyanızda başka şikayetleriniz varsa lütfen doğrudan mobilya satıcınıza danışın.

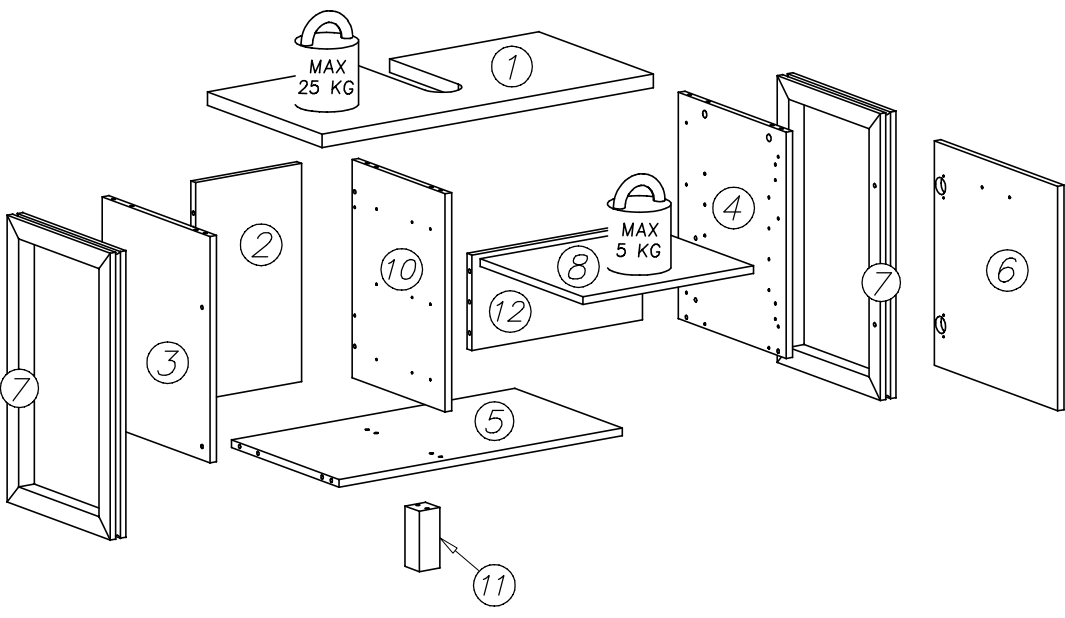

nr	L[mm]	B[mm]	T[mm]	Menge	Coili
1	810	400	28	1	1/1
2	452	259	16	1	1/1
3	469	376	16	1	1/1
4	469	376	16	1	1/1
5	692	375	16	1	1/1
6	465	430	16	1	1/1
7	594	360	38	2	1/1
8	417	302	16	1	1/1
10	452	324	16	1	1/1
11	125	50	50	1	1/1
12	417	198	16	1	1/1
13	219	300	3	3	1/1
14	273	153	16	3	1/1
15	300	100	12	3	1/1
16	300	100	12	3	1/1
17	209	100	12	3	1/1

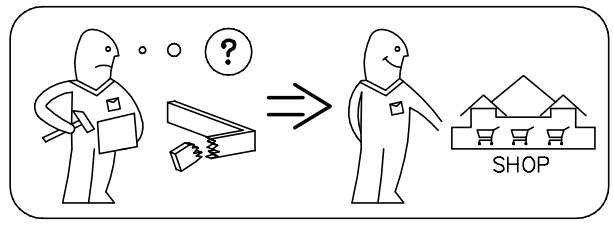
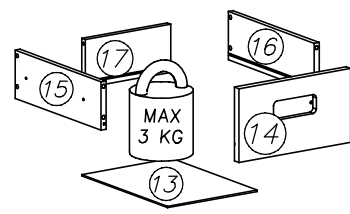

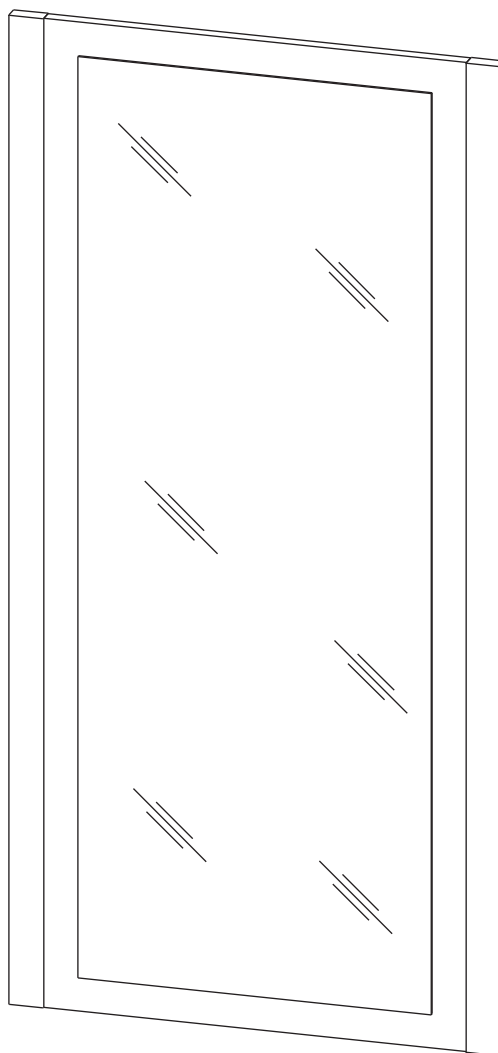
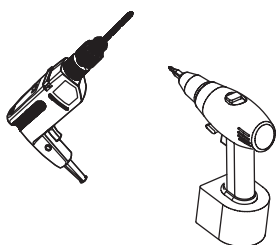
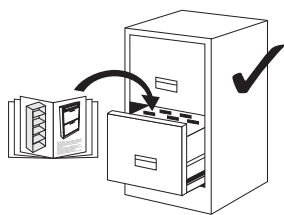
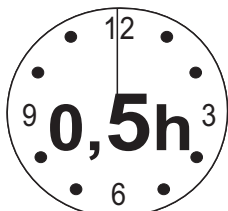

DETROIT 76

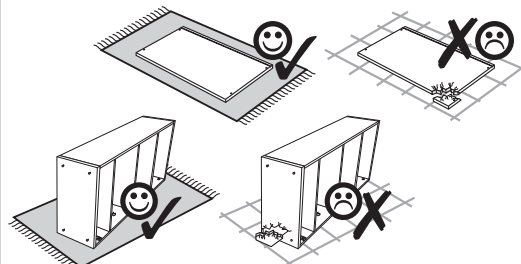
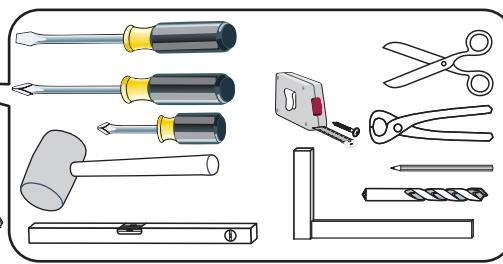
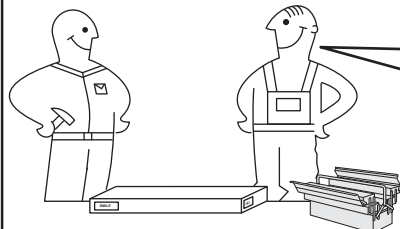

- Ⓛ Montageanleitung
- Ⓝ Handleiding voor de montage
- Ⓣ Montaj talimati
- ⓕ Instructions de montage
- Ⓒ Montá ní návod
- ⓗ Összeszerelési útmutató
- ⓖ Assembly instructions
- Ⓟ Instrukcja montażu
- Ⓡ Инструкции по монтажу
- Ⓡ Istruzioni di montaggio
- Ⓚ Montá ny návod
- Ⓡ Instrucțiuni de asamblare

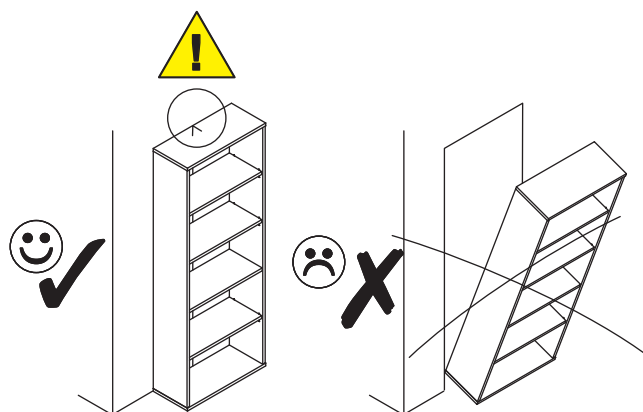



 Achtung • Opgelet • Uwaga • Dikkat • Внимание • Attention •Upozornění • Figyelem • Attenzione • Atenție 	
D	Überschreiten Sie angegebenen Maximalbelastungen nicht. Andernfalls kann das Möbelstück beschädigt oder zerstört werden.
GB	Do not exceed the maximum loads specified. Otherwise, the furniture may sustain damage or be irreparably damaged.
NL	Overschrijd de aangegeven maximale belastingen niet. Anders kan het meubelstuk worden beschadigd of vernield.
PL	Nie wolno przekraczać podanych maksymalnych wartości obciążenia. W przeciwnym razie mebel może zostać uszkodzony lub zniszczony.
TR	Belirtilen azami yük deđerini atmayınız, aksi takdirde mobilya parçası zarar görebilir veya kullanılamaz hale gelebilir.
RU	Не допускается превышение указанных максимальных нагрузок. В противном случае возможно повреждение или разрушение мебели.
FR	Ne dépassez pas les charges maximum indiquées. Sinon, le meuble peut être endommagé ou détruit.
CZ	Nepřekračujte uvedená maximální zatížení. V opačném případě může dojít k poškození nebo zničení nábytku.
HU	Tartsa be az engedélyezett maximális terhelhetőséget/teljesítményt. Különben a bútor és annak alkatrészei megsérülhetnek, tönkre mehetnek.
IT	Non superare il carico massimo indicato. Altrimenti il mobile rischia di rovinarsi o frantumarsi.
RO	Nu depășiți solicitările maxime specificate. Altfel puteți să deteriorați sau să distrugeți piesa de mobilier.
SK	Neprekročte uvedené maximálne zaťaženia. V opačnom prípade sa môže nábytok poškodiť alebo zničiť.
D	Die Befestigung des Möbelstückes an der Wand muss von einer fachkundigen Person vorgenommen werden, da für die Montage an die Wand angepasste Dübel erforderlich sind.
GB	A qualified professional is required when mounting furniture to the wall since dowels corresponding to the wall are required for this.
NL	Een vakkundige persoon dient het meubelstuk aan de muur te bevestigen; voor de montage aan de muur zijn immers aangepaste pluggen vereist.
PL	Mocowanie mebla do ściany mogą przeprowadzić wyłącznie wykwalifikowane osoby, z uwagi na zastosowanie odpowiednio dopasowanych kołków do rodzaju ściany.
TR	Mobilya parçasının duvara sabitlenmesi, duvar montajı için özel uyarlanmış dübeller gerektirdiğinden bu iş sadece bu konuda uzman bir kişi tarafından gerçekleştirilmelidir.
RU	Поскольку для монтажа на стене необходимо использовать специальные дюбели, мебель должна быть закреплена на стене квалифицированным персоналом.
FR	La fixation du meuble contre le mur doit être effectuée par une personne compétente car, pour le montage mural, il faut utiliser des chevilles adaptées.
CZ	Montáž nábytku na stěnu musí provést odborník, protože k montáži na stěnu jsou zapotřebí upravené hmoždinky.
HU	A bútorlemek falra rögzítését szakembernek kell végeznie, mert a rögzítéshez megfelelő tiplít kell használni.
IT	Il fissaggio del mobile alla parete deve essere eseguito da persone esperte, dato che occorrono tasselli adeguati.
RO	Fixarea la perete a piesei de mobilier se realizează numai de către personal competent, deoarece montajul de perete necesită dibluri adecvate.
SK	Upevnenie nábytku na stenu musí vykonať odborník, nakoľko sú pre montáž na stenu potrebné vhodné hmoždinky.

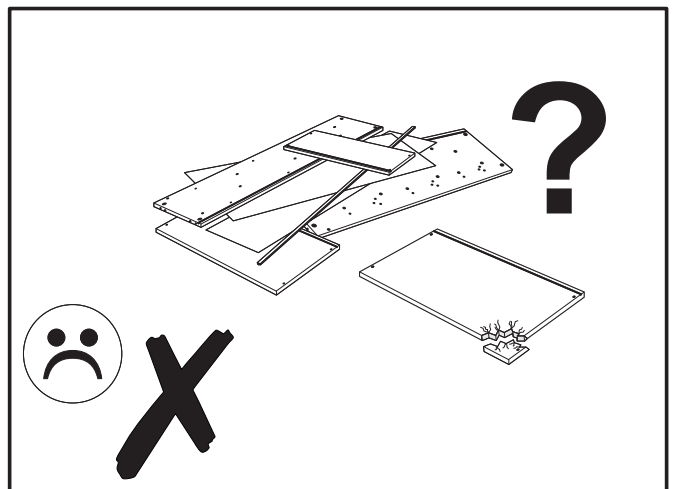
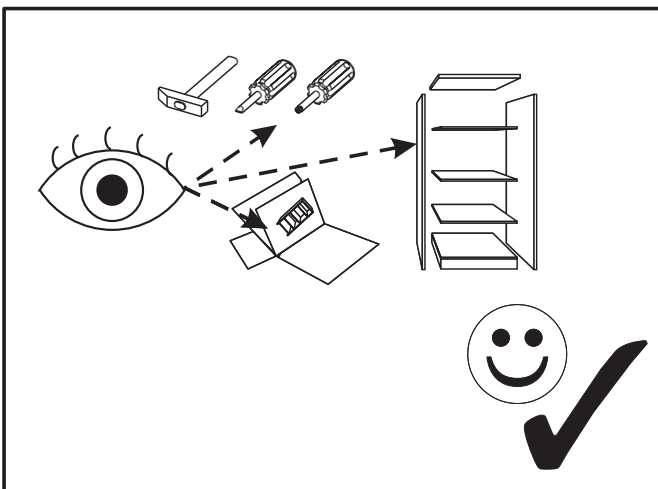
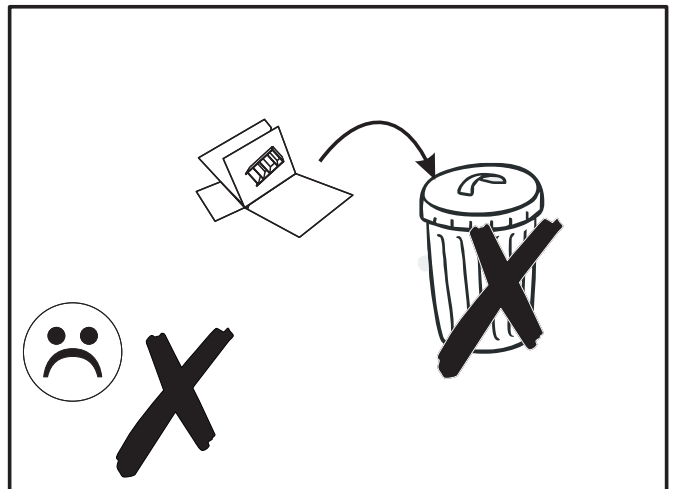
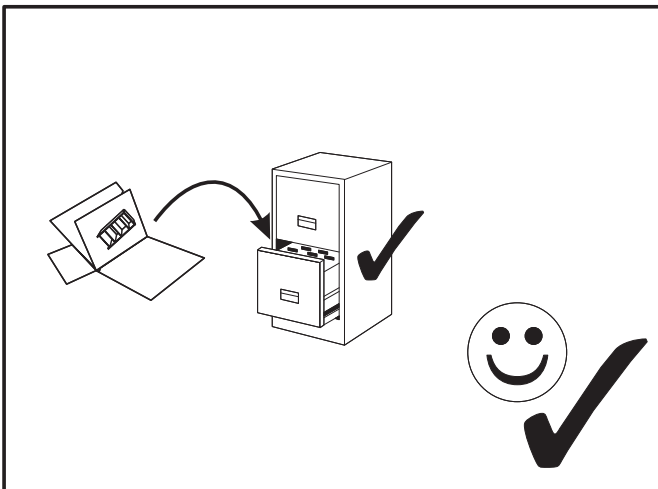
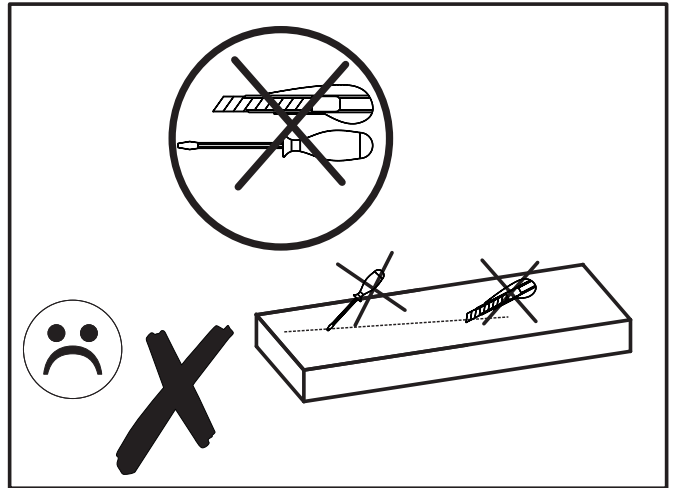
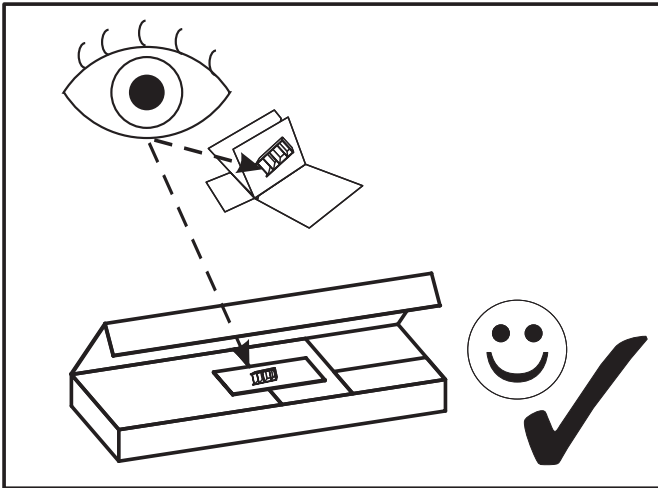

DETROIT 76

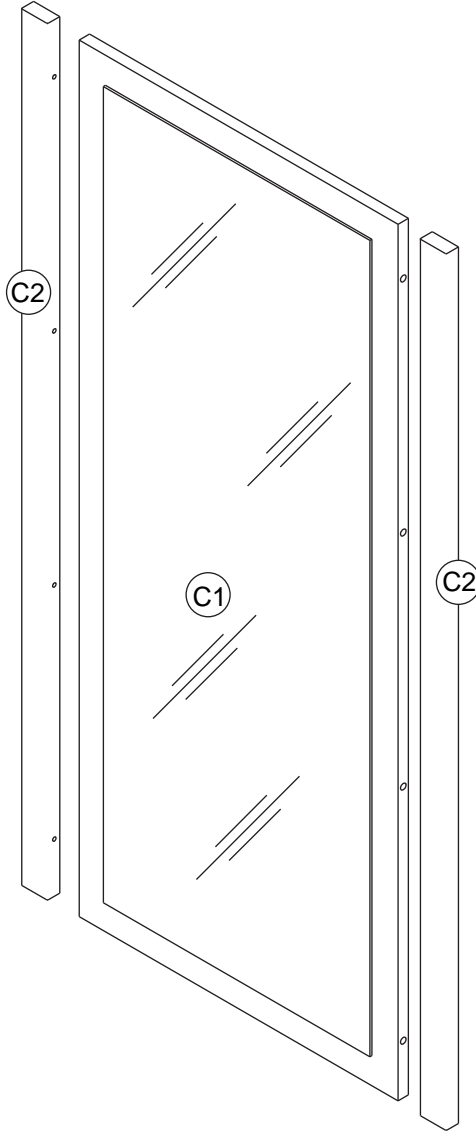
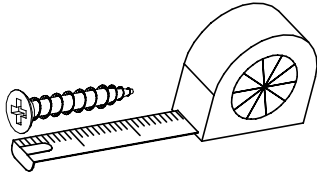
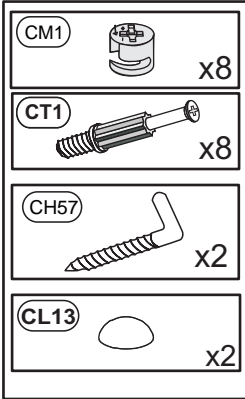

C1	1080	464	16	1	1/1
C2	1080	38	18	2	1/1

1

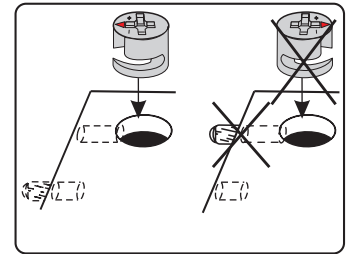
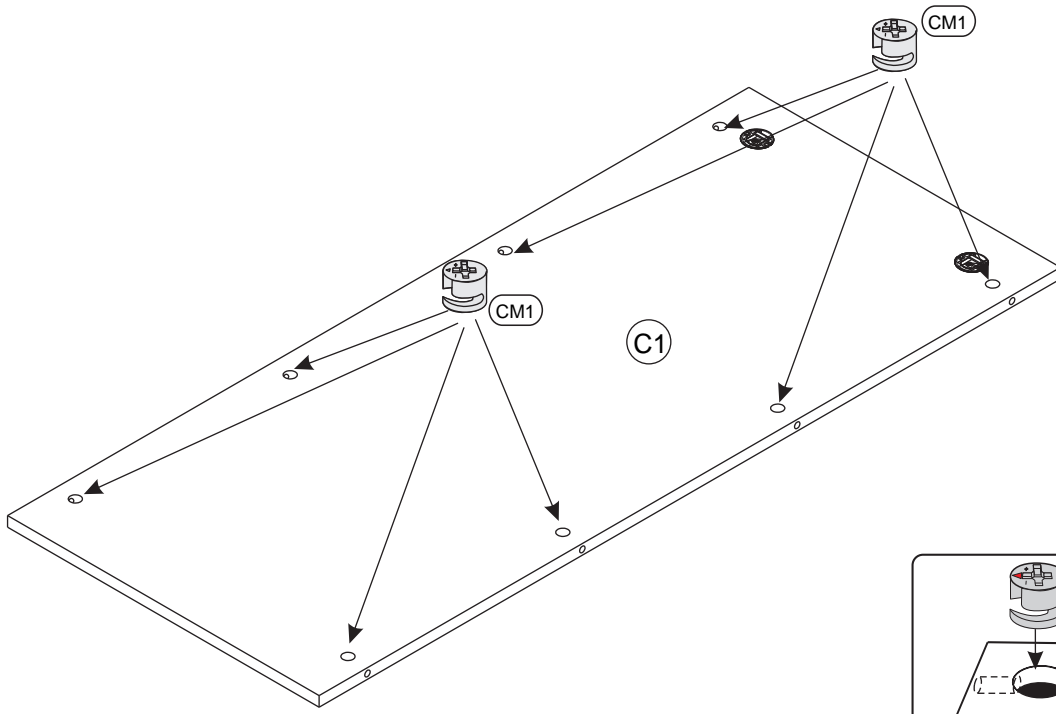
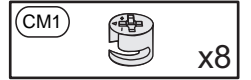

2

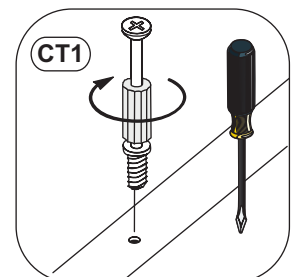
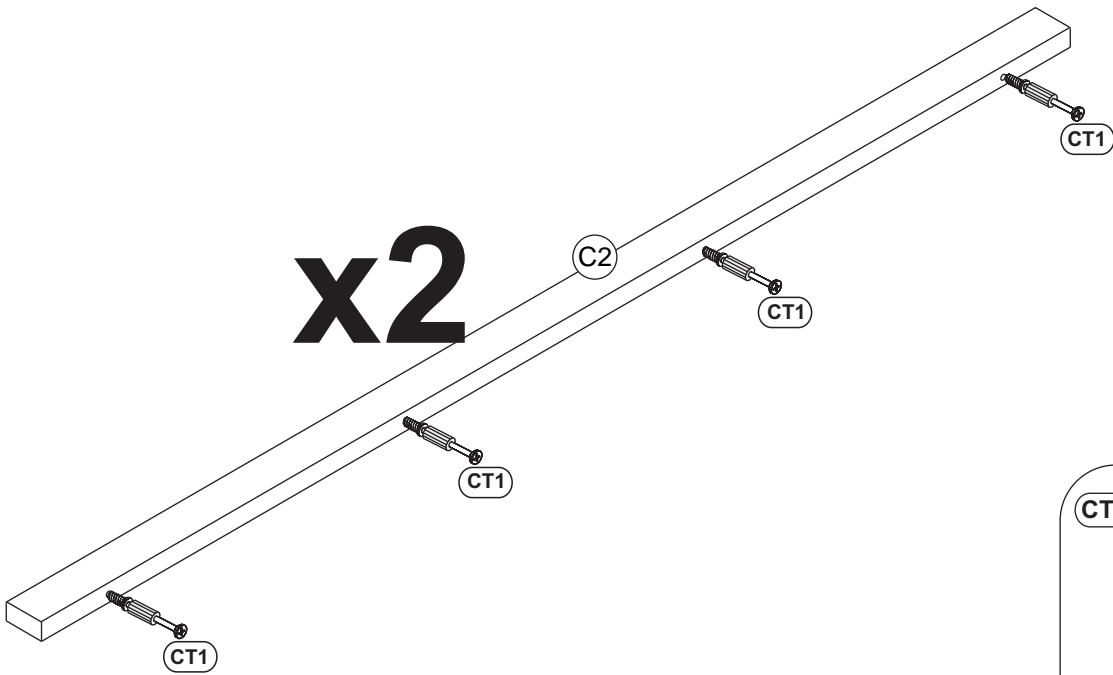
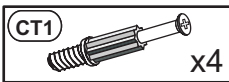

3

CL13  x2

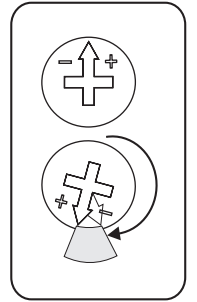
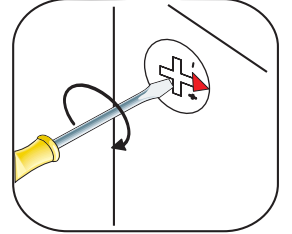
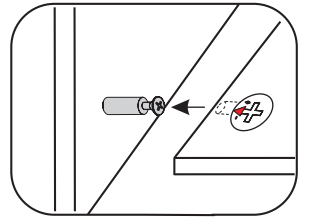
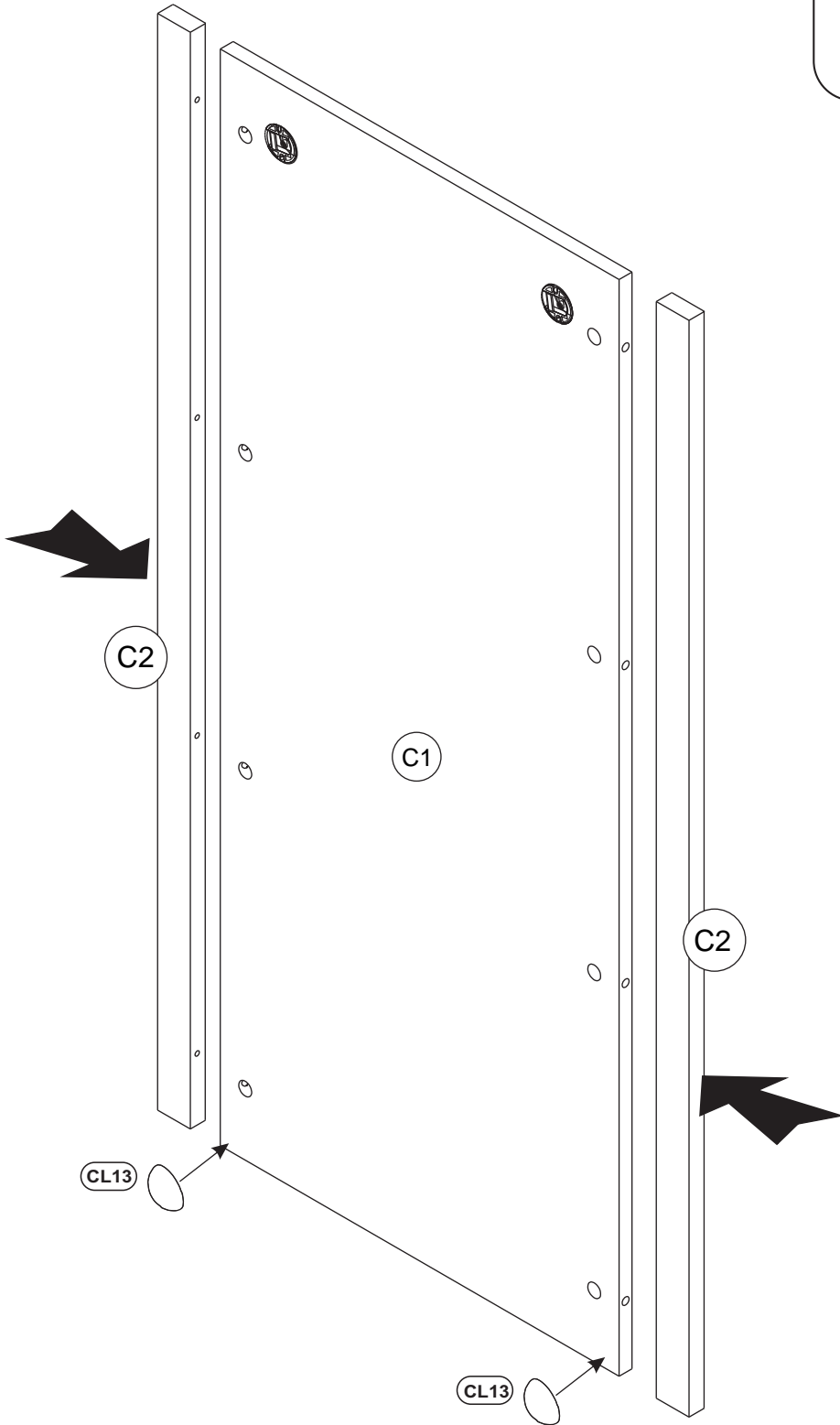

4

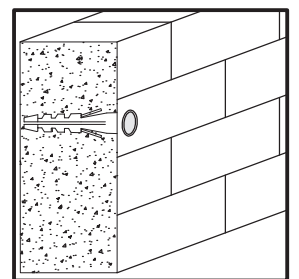
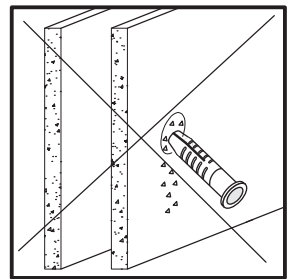
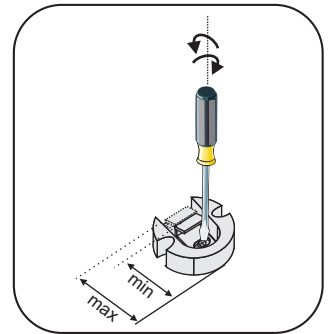
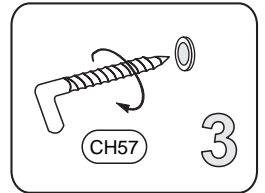
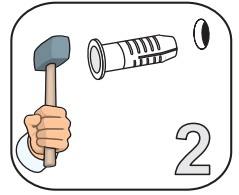
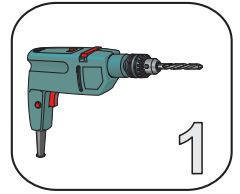
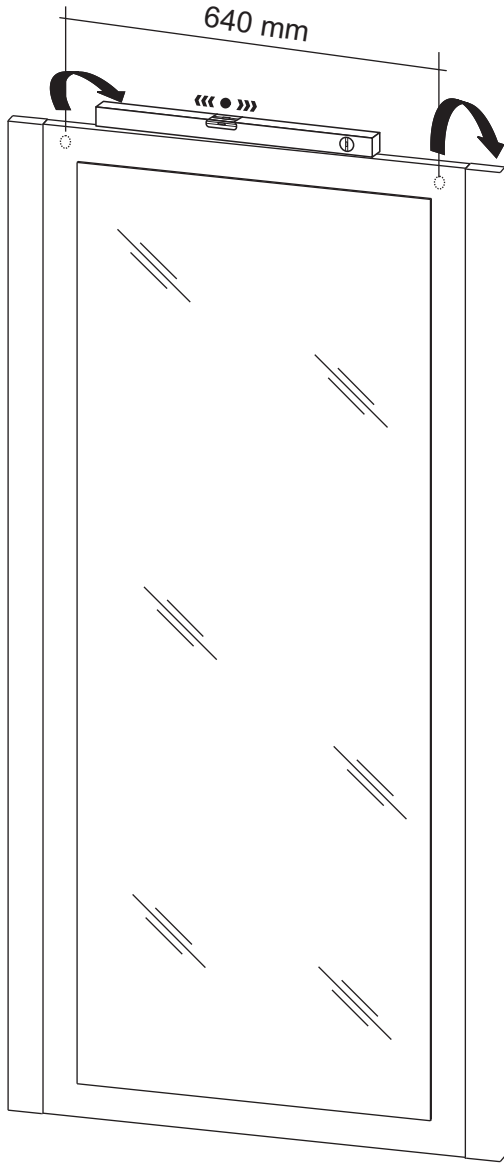

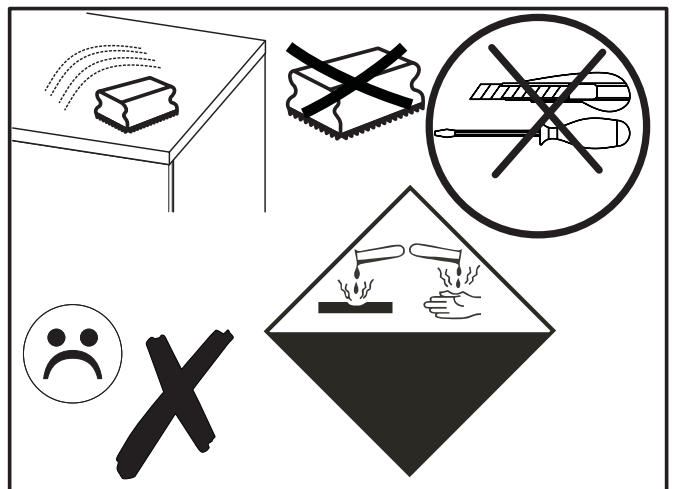
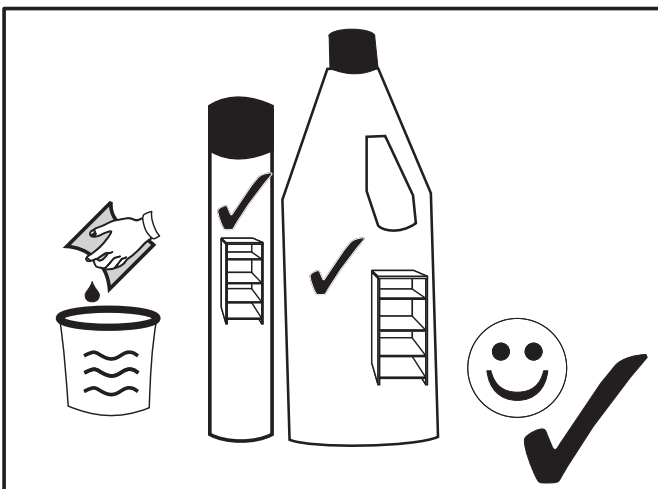
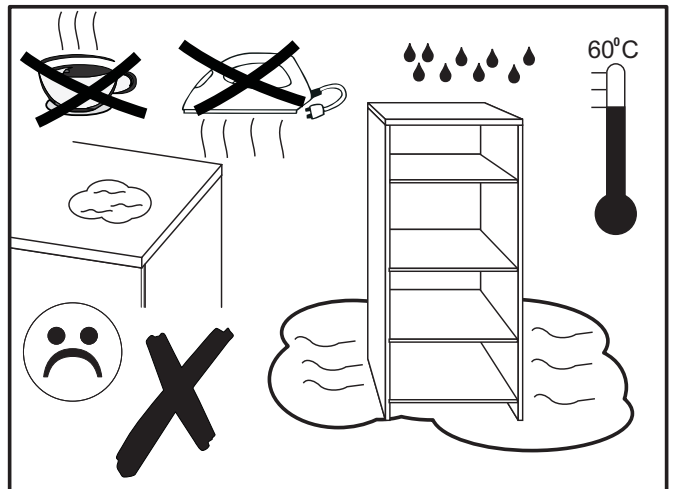
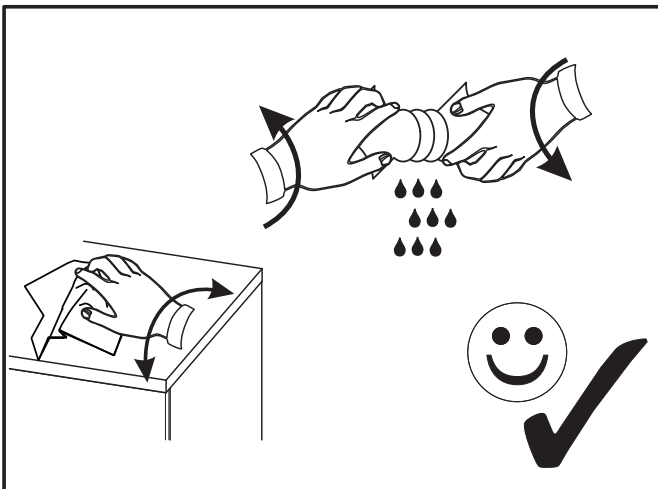
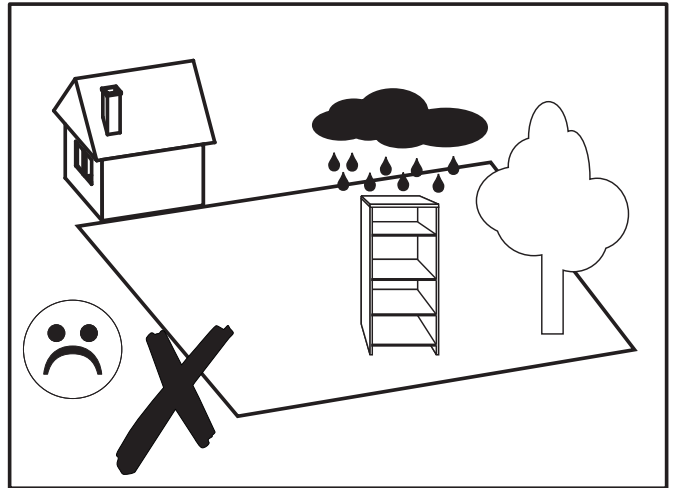
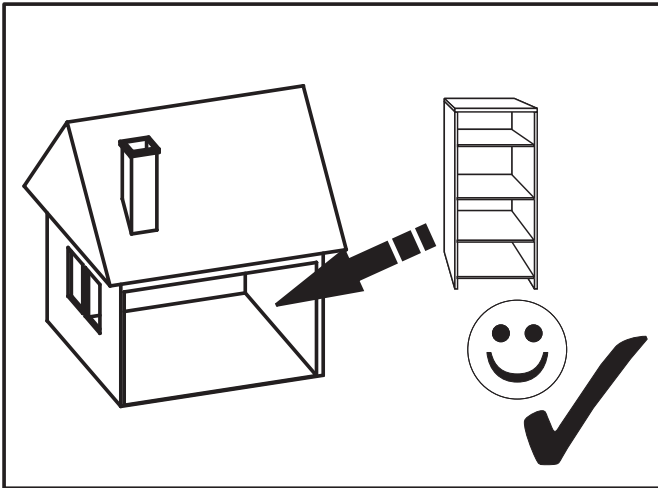

DETROIT 76

Unser Direktservice für Beschlagteile

Sollte Ihnen ein Beschlagteil fehlen, können Sie diese Servicekarte direct an die untenstehende Nummer senden. Wir können allerdings nur Beschlagteile auf diesem Weg verschicken. Sollen Sie eine andere Beanstandung an Ihrem Möbelstück haben, so wenden Sie sich bitte direkt an Ihr Möbelhaus.

D

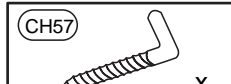
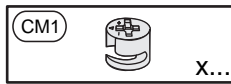

Our direct order service for fitting

If a fitting should be missing to you, you know this service map directly following number faxes. We can in this way send away however only fitting. If you should have another objection to your piece of furniture, then they turn please to your furniture house.

GB

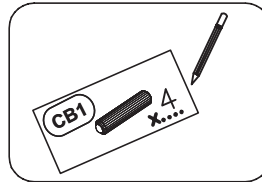
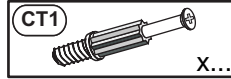

Naše přímé služby pro kování

Chybi-li vám nějaký díl z kování, můžete tuto servisní kartu odfaxovat přímo na níže uvedené číslo. Touto cestou však můžeme rozesílat jen díly kování. Pokud byste reklamovali jiný díl nábytku, obraťte se přímo na svého prodejce nábytku.

CZ

Bien etudier la notice de montage

Reperiez les pieces constituant votre meuble. Regroupez et controlez la quincaillerie. Munissez - vous de l'outillage necessaire. Amenagez - vous une zone de montage. Procédez au montage. Ne jamais forcer les assemblages. Resserrez les vis apres quelques temps d'usage. Garder votre notice de montage, si une piece venait a manquer, elle serait le plus clair moyen de communiquer avec votre magasin.

F

Il nostro servizio diretto per l'ordine della ferramenta

Nel caso vi mancassero dei pezzi, potete spedire fax questa carta die servizi direttamente al seguente numero. Per altri reclami al vostro mobile, potete rivolgervi al vostro mobilificio.

I

Дієдально обслуговуємі наші "Обовов"

Якщо у вас відсутній якийсь елемент фурнітури, можете надіслати цю картку поштою на нижче вказаний номер факсу. Ми можемо надіслати тільки елементи фурнітури. Якщо ви хочете скарги на інший елемент мебелі, зверніться безпосередньо до магазину мебелі.

BG

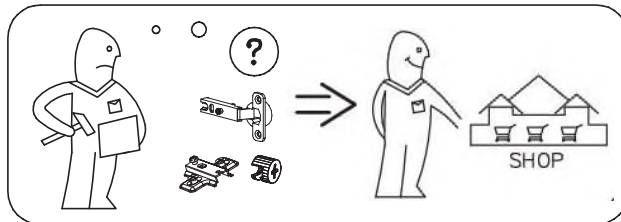

Onze directservice voor losse onderdelen

Wanneer er een onderdeel mist kunt u deze servicekaart direct aan onderstaand faxnummer sturen. Wij kunnen alleen langs deze weg onderdelen versturen. Mocht u een ander probleem aan uw meubel hebben verzoeken wij u contact op te nemen met uw meubeldealer.

NL

Nasz bezpośredni serwis części montażowych

Jeżeli brakuje części koniecznych do montażu, prosimy o przesłanie nam tej karty serwisowej na niżej podany numer faxu. Możemy w ten sposób przysłać państwu tylko brakujące części. W przypadku innych obiekcji dotyczących mebla, prosimy o zgłoszenie ich do salonu meblowego w którym został dokonany zakup.

PL

Serwis za okove

U slučaju da nedostaje neki od dijelova molimo vas da na dolje navedeni Fax broj posaljete ovaj servisni obrazac. Na ovaj nacin mogu se dostaviti samo okovi. U slučaju da imate dodatne prigovore vezane uz komad namjestaja molimo vas da se obratite izravno trgovini namjestaja gdje je isti kupljen.

HR

Direktszolgáltatunk vasalatok esetén

Ha hiányzik egy vasalat, ezt a kártyát közvetlenül elfaxolhatja az alább található faxszámra. Azonban csakis vasalatosokat tudunk így küldeni. Amennyiben másfajta reklamáció áll fenn bútordarabját illetően, forduljon közvetlenül a bútortárhoz.

HU

Náš priamy servis pre časti kovania

Ak by Vám chýbala nejaká časť kovania, môžete poslať túto servisnú kartu poslať faxom priamo na nižšie uvedené faxové číslo. Diely kovania vieme poslať iba týmto spôsobom. Ak by sie mali inú reklamáciu ohľadom Vášho nábytku, obráťte sa priamo na Vašu predajnu nábytku.

SL

Naše direktne služne storitve za okovje

Ce vam manjka kakšno okovje, lahko to servisno kartico pošljete po faksu direktno na spodnjo številko. Po tej poti vam lahko pošljemo samo okovje. Če želite reklamirati kakšen drug del pohištva, se obrnite neposredno na vašo trgovino pohitva.

SLO

Service-ul nostru direct pentru feronerie

In cazul in care va lipsieste o piesa de feronerie puteti să trimiteti direct acest card de service pe fax la numărul de mai jos. Noi nu putem expedia piese de feronerie decât pe această cale. Dacă aveți o altă reclamație referitoare la piesa de mobilier, atunci vă rugăm să vă adresați direct la magazinul dvs. de mobilă.

RO

Наш прямой сервис для поставок фурнитуры

Если окажется, что Вам не хватает того или иного элемента Фурнитуры, Вы можете отправить сервисную карту по Факсу непосредственно на нижеприведенный номер. Однако, таким образом мы можем пересылать лишь фурнитуру. Если же у Вас возникнут иные претензии относительно приобретенной мебели, пожалуйста, обращайтесь непосредственно в организацию, осуществившую продажу.

RUS

Vår direktservice för beslagsdelar

Om du saknar en beslagsdel kan du faxa detta servicekort direkt till numret som anges ned. Tänk pa att detta är den enda möjligheten att skicka beslagsdelar till dig. Om du vill reklamera din möbel av en annan anledning måste du kontakta ditt möbelhus direkt.

S

Nuestro servicio directo para accesorios

Si le falta algún accesorio, puede enviar esta tarjeta de servicio directamente a la siguiente dirección. No obstante, por este método solo podemos enviar accesorios. Si tiene alguna otra objeción sobre su mueble, consulte directamente con su muebleria.

ES

Donatilar için doğrudan servisimiz

Bir donatınız eksikse bu servis kartını doğrudan aşağıda bulunan adrese doğrudan mail yazabilirsiniz. Sadece bu yolla donatılar gönderiliriz. Mobilyanızda başka şikayetlerimiz varsa lütfen doğrudan mobilya satıcınıza danışın.

TR

C1	1080	464	16	1	1/1
C2	1080	38	18	2	1/1

