

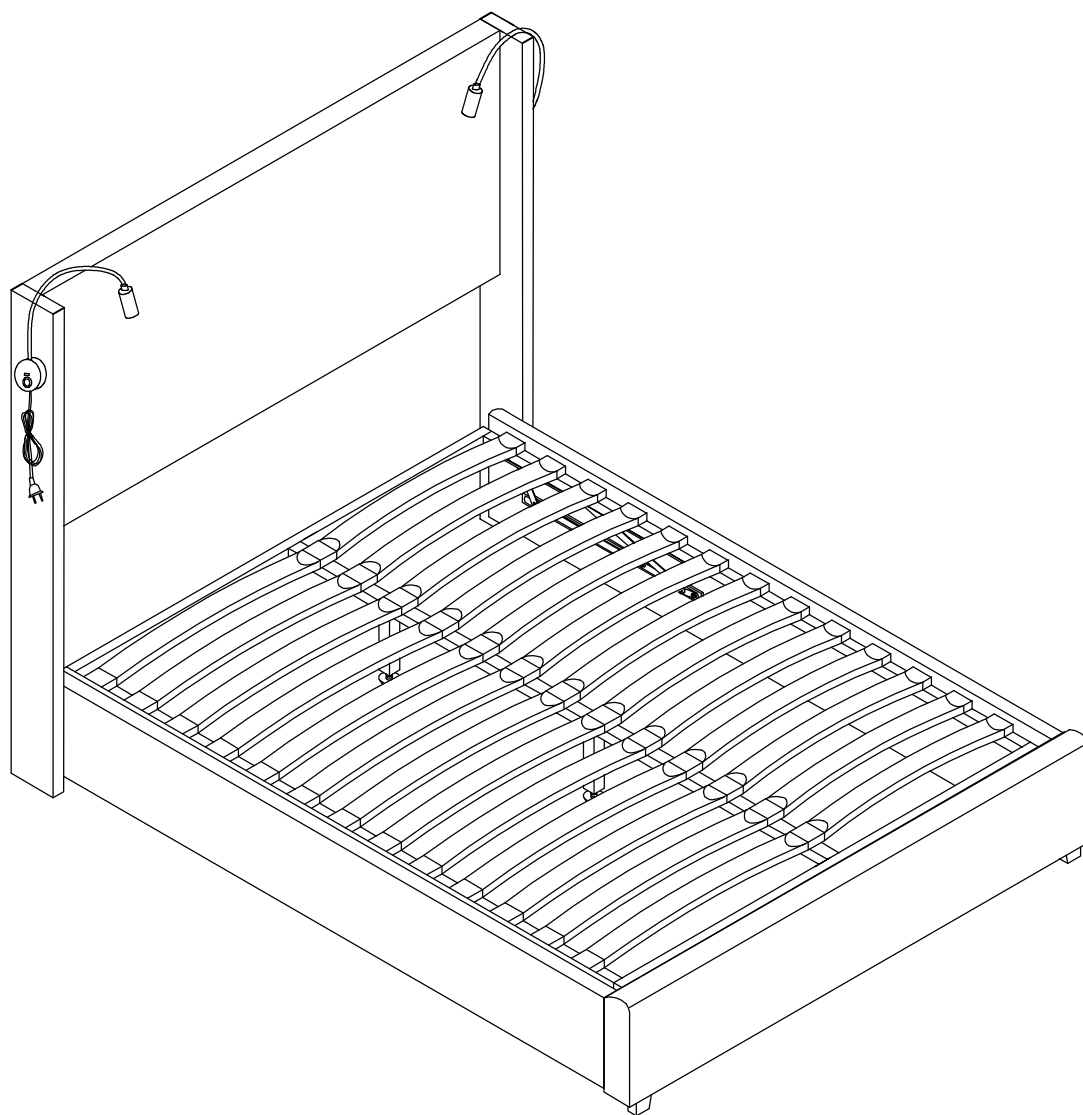

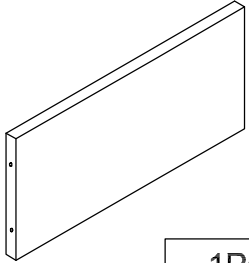

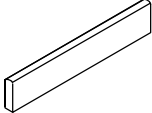

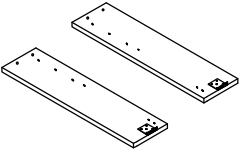
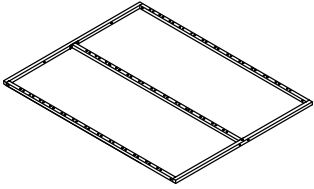

Instruction Manual

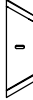
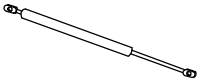
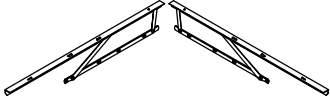

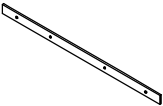
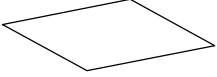

Upholstered Bed Frame
FULL/ QUEEN SIZE





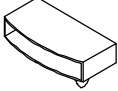
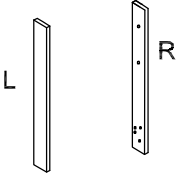

Assembly Steps(EN)

<p>① Headboard Box</p>  <p>1PC</p>	<p>② Footboard</p>  <p>1PC</p>	<p>③ Side Rail</p>  <p>2PCS</p>
<p>④ Bed Slat Frame</p>  <p>1 Sets</p>	<p>⑤ Slats</p>  <p>24PCS</p>	<p>⑥ Bed Slat Frame Support Plat</p>  <p>2PCS</p>
<p>⑦ Pneumatic Rod</p>  <p>2PCS</p>	<p>⑧ Bed Support Rack</p>  <p>2PCS</p>	<p>⑨ Barcket</p>  <p>1PC</p>
<p>⑩ Support Leg</p>  <p>2PCS</p>	<p>⑪ Centre Cross Bar</p>  <p>1PC</p>	<p>⑫ Sheet Iron</p>  <p>2PCS</p>
<p>⑬ Bottom Dustproof Cover</p>  <p>1PC</p>	<p>⑭ FB Leg</p>  <p>2PCS</p>	<p>⑮ Barcket</p>  <p>2PCS</p>

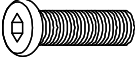
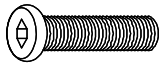
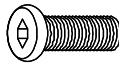
Assembly Steps(EN)

<p>①⑥ Drawstring</p>  <p>1PC</p>	<p>①⑦ Centre Connector</p>  <p>12PCS</p>	<p>①⑧ End Cap</p>  <p>24PCS</p>
<p>①⑨ Headboard Side Panel</p>  <p>2PCS</p>		

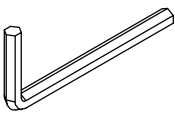
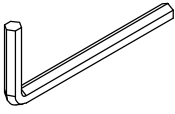
Assembly Steps(EN)

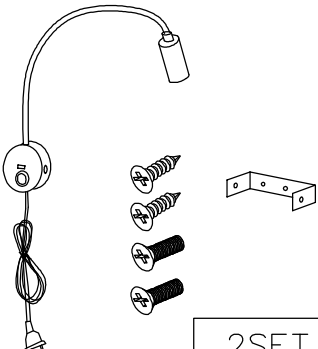
<p>A</p>  <p>$\varnothing 5/16'' \times 45\text{mm}$ 34+2PCS</p>	<p>B</p>  <p>$\varnothing 1/4'' \times 35\text{mm}$ 8+1PCS</p>	<p>C</p>  <p>$\varnothing 1/4'' \times 15\text{mm}$ 10+1PCS</p>
<p>D</p>  <p>$\varnothing 5/16'' \times 12\text{mm}$ 34+2PCS</p>	<p>E</p>  <p>$\varnothing 5/16'' \times 19\text{mm}$ 34+2PCS</p>	<p>F</p>  <p>$\varnothing 1/4'' \times 16\text{mm}$ 18+2PCS</p>
<p>G</p>  <p>$\varnothing 5/16''$ 14+2PCS</p>	<p>H</p>  <p>$5/16''$ 1PC</p>	<p>I</p>  <p>$1/4''$ 1PC</p>
<p>J</p>  <p>$5/16''$ 1PC</p>	<p>K</p>  <p>2SET</p>	

Assembly Steps(EN)

STEP 1

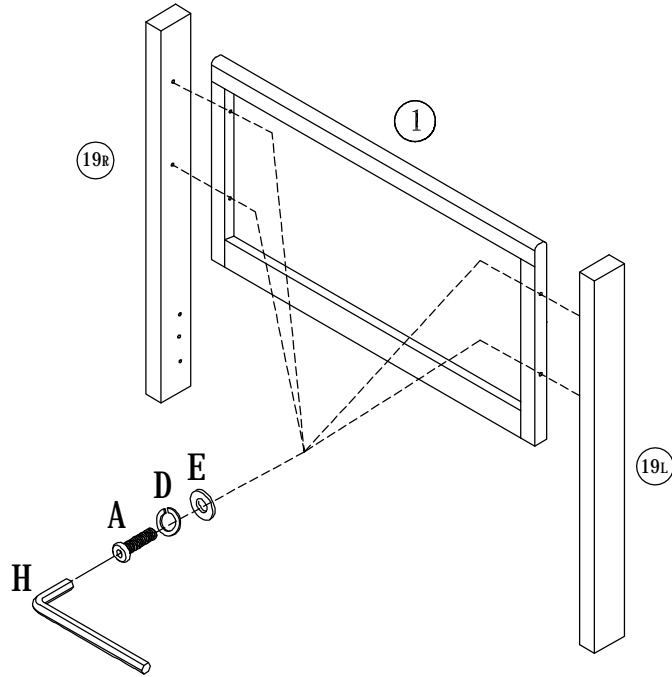

	A x 4PCS
	D x 4PCS
	E x 4PCS
	H x 1PC

STEP 2

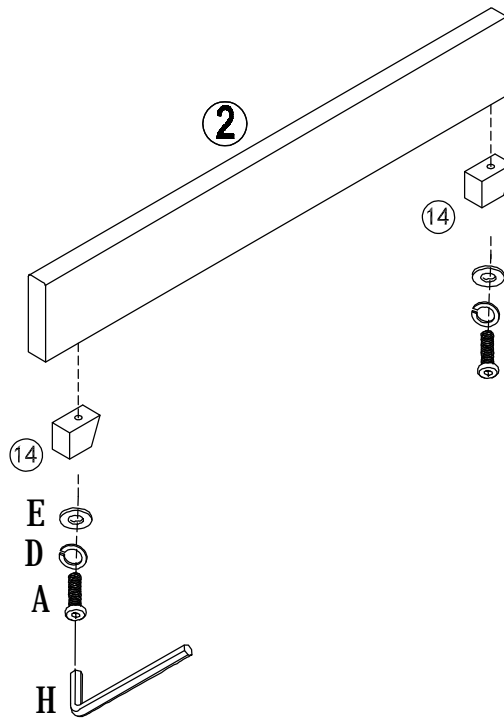



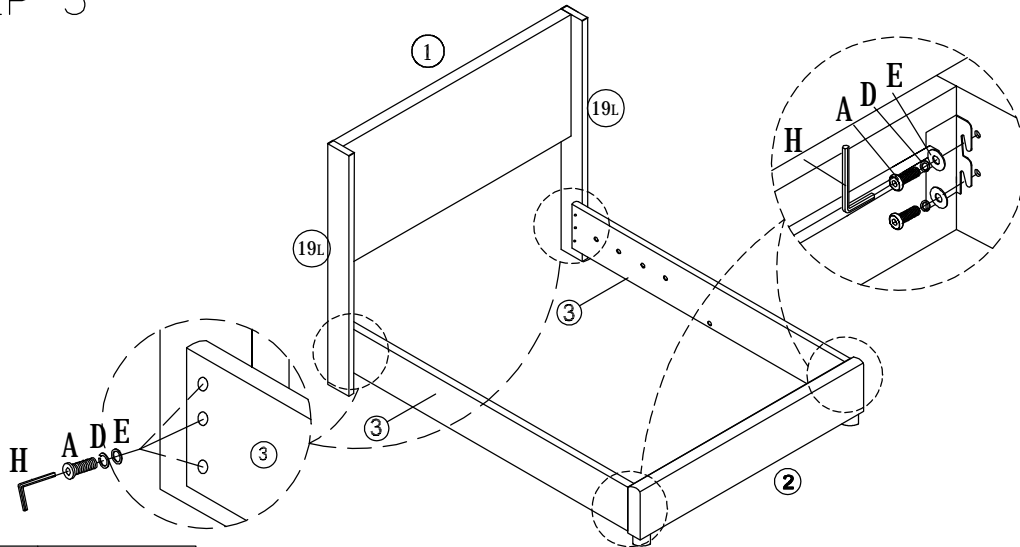

	A x 2PCS
	D x 2PCS
	E x 2PCS
	H x 1PC

Assembly Steps(EN)







STEP 3

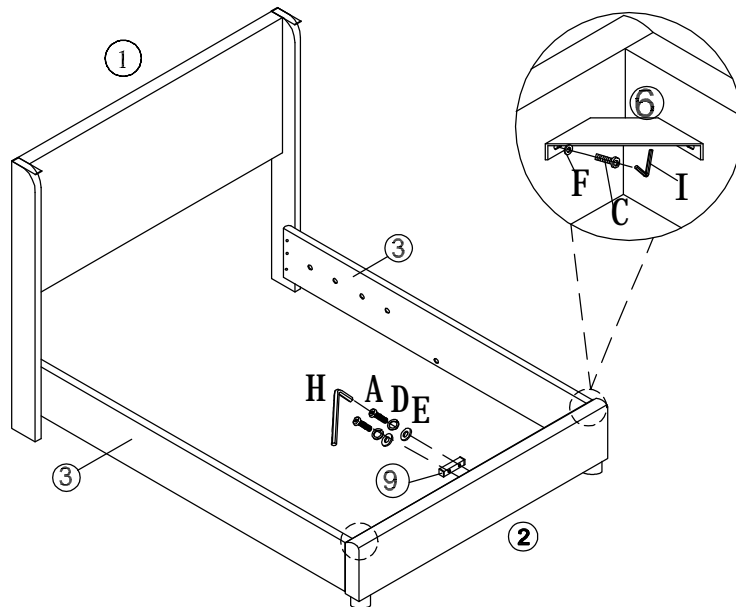

	A x 10PCS
	D x 10PCS
	E x 10PCS
	H x 1PC

STEP 4





	A x 2PCS		
	C x 8PCS		
	D x 4PCS		
	E x 6PCS		H x 1PC
	F x 8PCS		I x 1PC

Assembly Steps(EN)

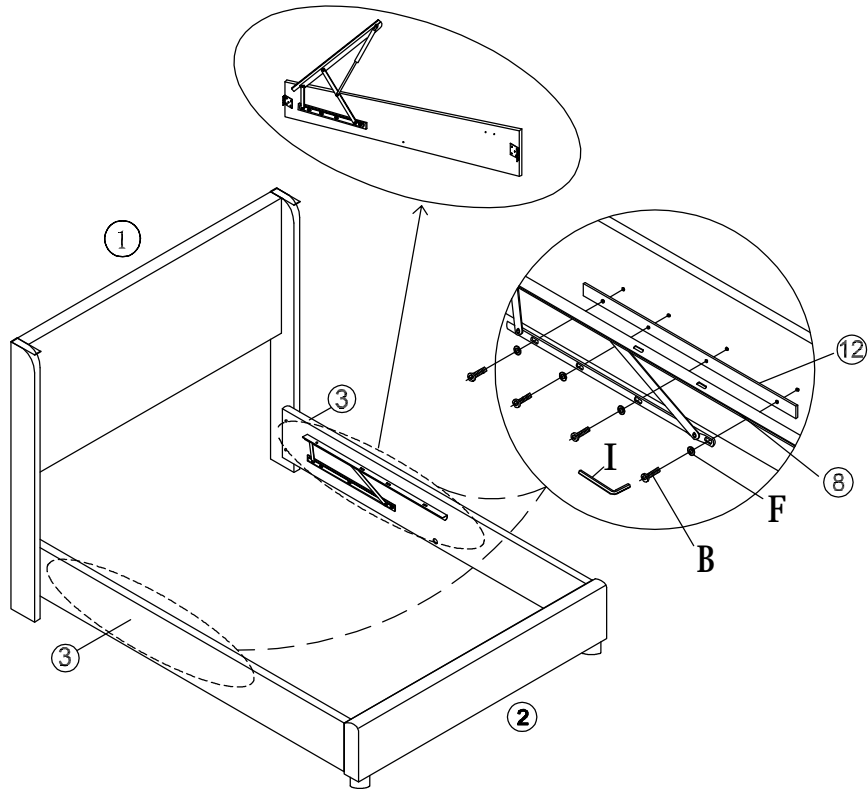

STEP 5

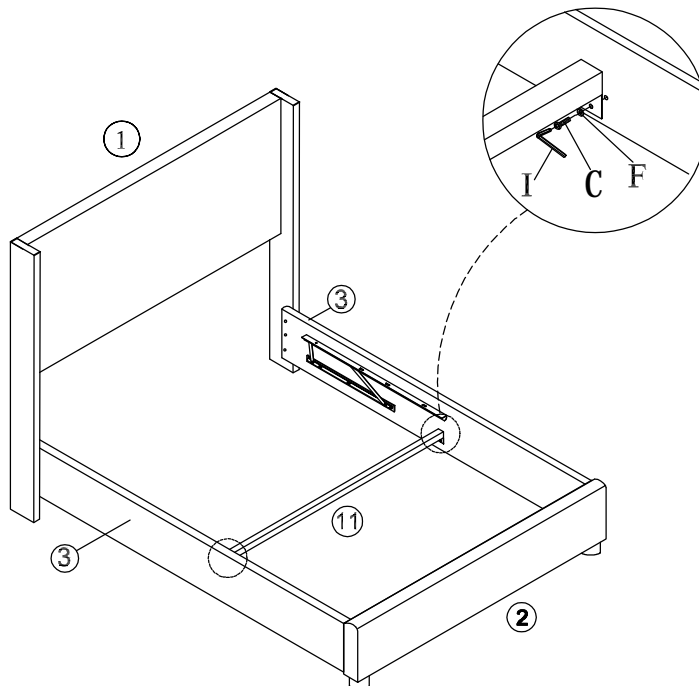

	B x 8PCS
	F x 8PCS
	I x 1PC

STEP 6



	C x 2PCS
	F x 2PCS
	I x 1PC

Assembly Steps(EN)

STEP 7

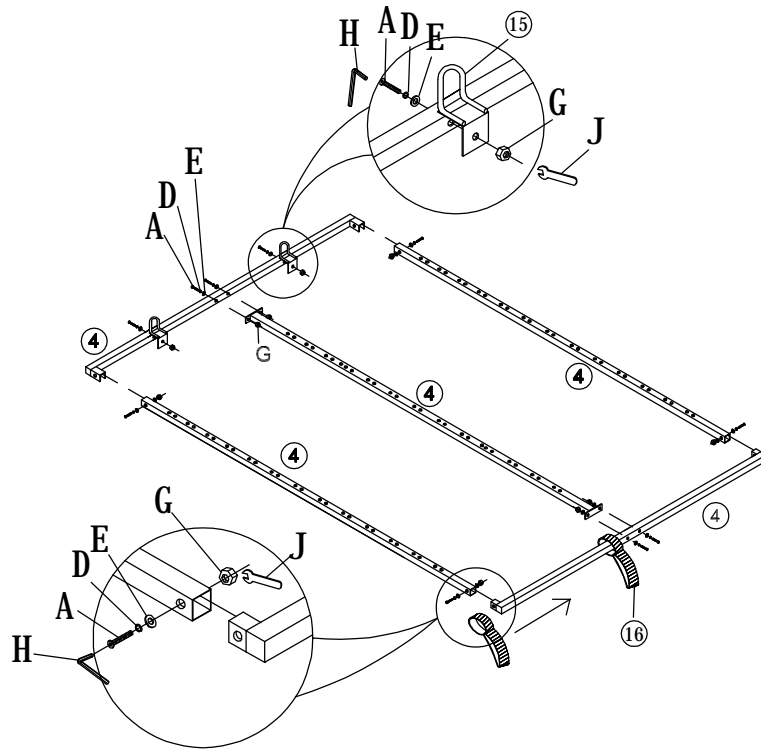

	A x 10PCS
	D x 10PCS
	E x 10PCS
	G x 10PCS
	H x 1PC
	J x 1PC

STEP 8

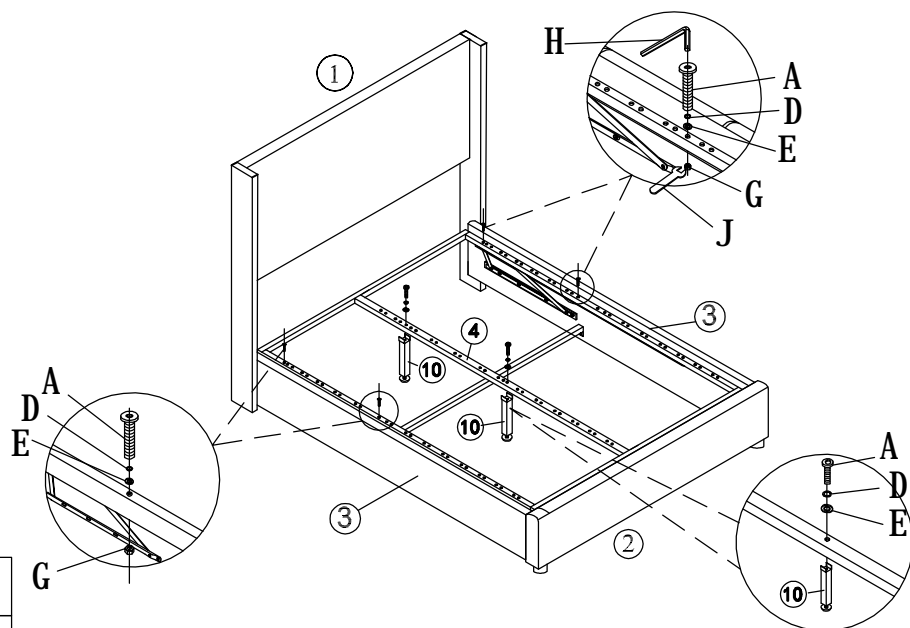

	A x 6PCS		
	D x 6PCS		
	E x 6PCS		H x 1PC
	G x 4PCS		J x 1PC

Assembly Steps(EN)

STEP 9

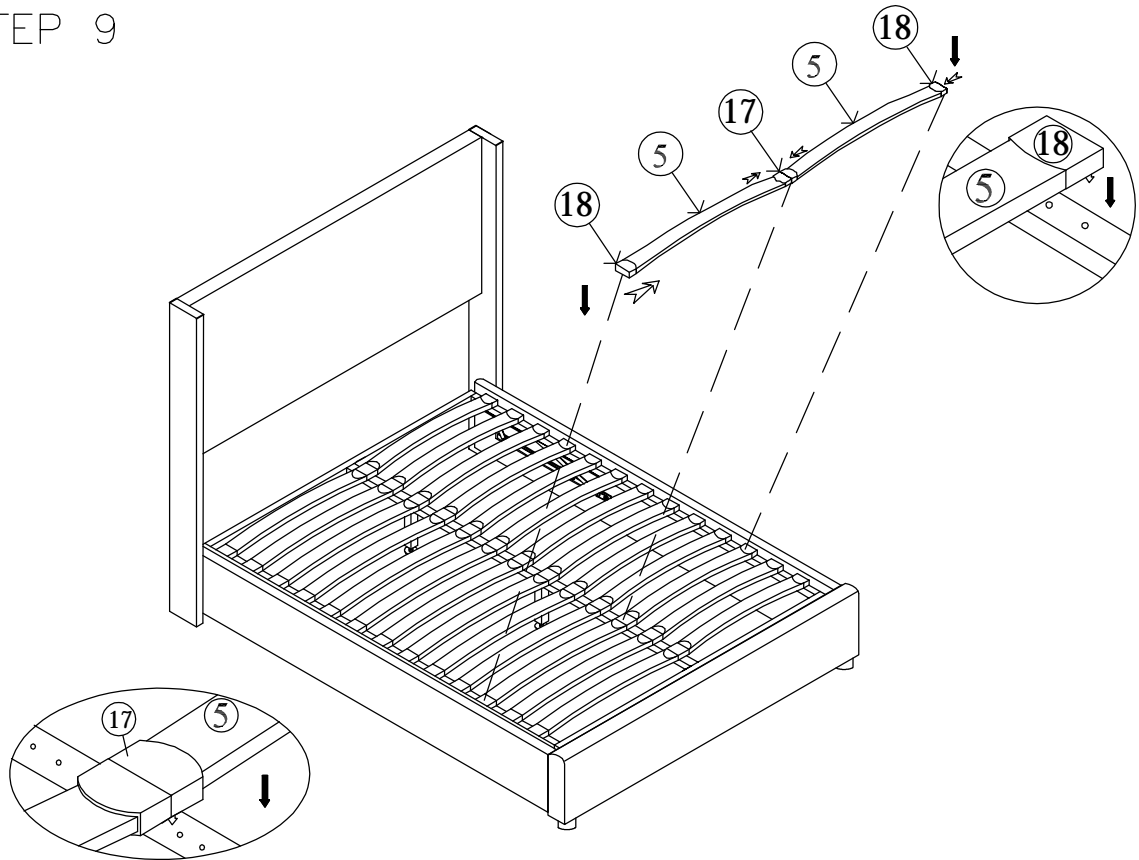

STEP 10

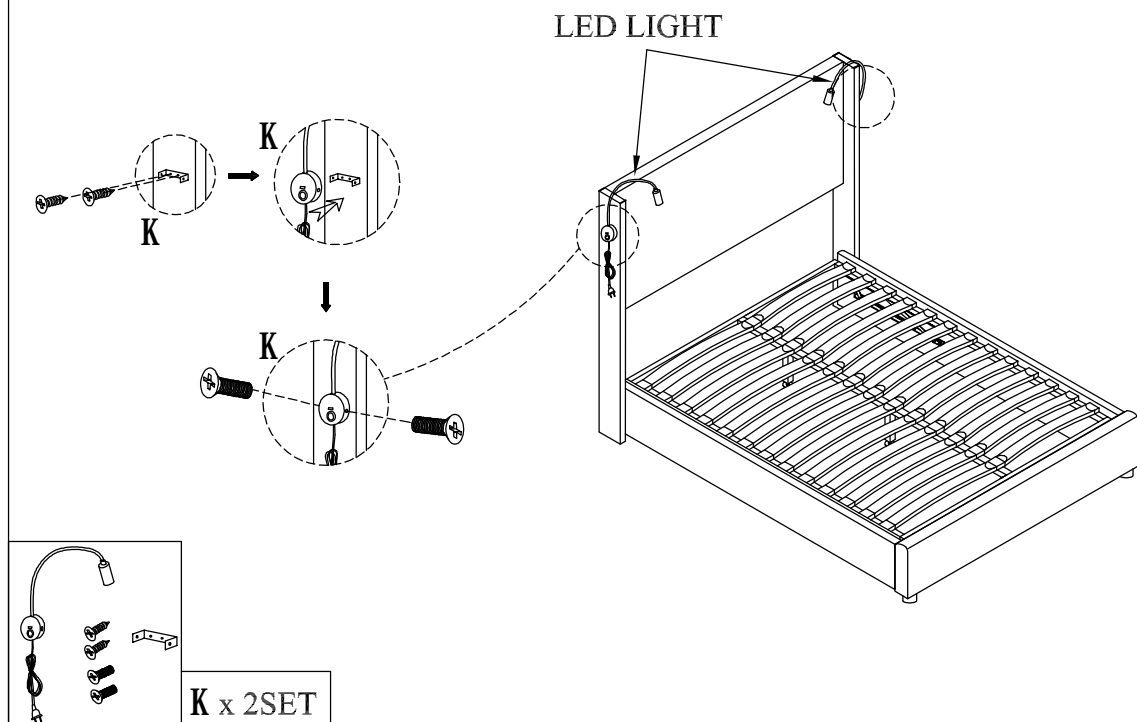

Assembly Steps(EN)

STEP 11

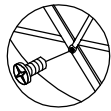
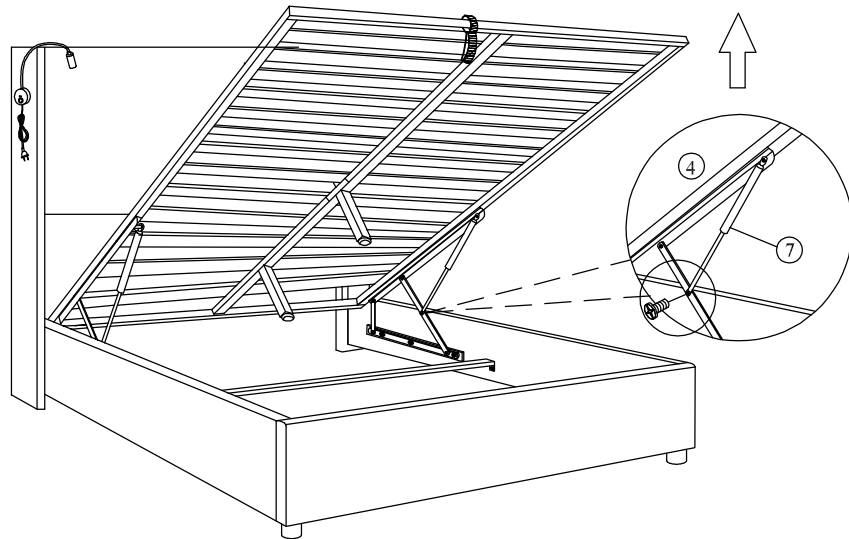

**SCHRAUBEN SIE DIESE SCHRAUBE (1 STÜCK) VON TEIL H AB;
HEBEN SIE DANN DIE BASIS AUF DIE MAXIMALE HÖHE AN.
SCHRAUBEN SIE DEN BOLZEN FEST AN ;**

STEP 12

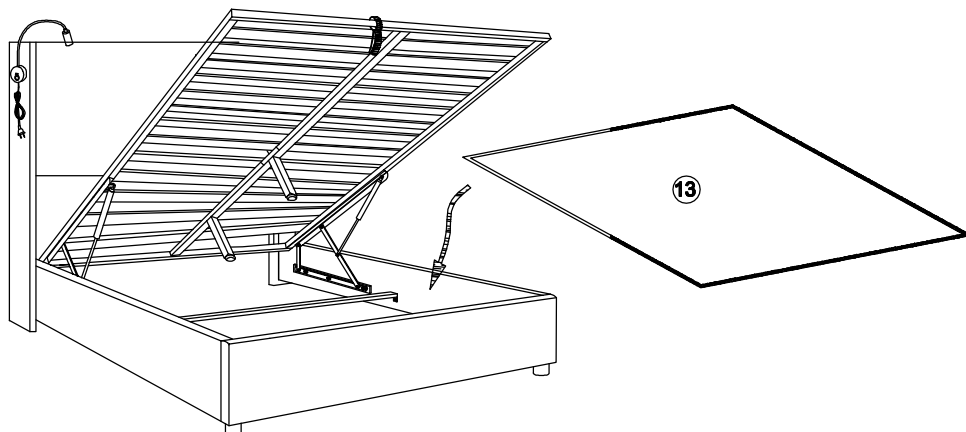

Assembly Steps(EN)

STEP 13

