

ASSEMBLY INSTRUCTION/MONTAGEANLEITUNGEN

WAVE BED (GERMANY) QUEEN/FULL

WF314361/WF314362 (140 x 200 cm)

WF314363/WF314364 (160 x 200 cm)



Detail View - WAVE BED

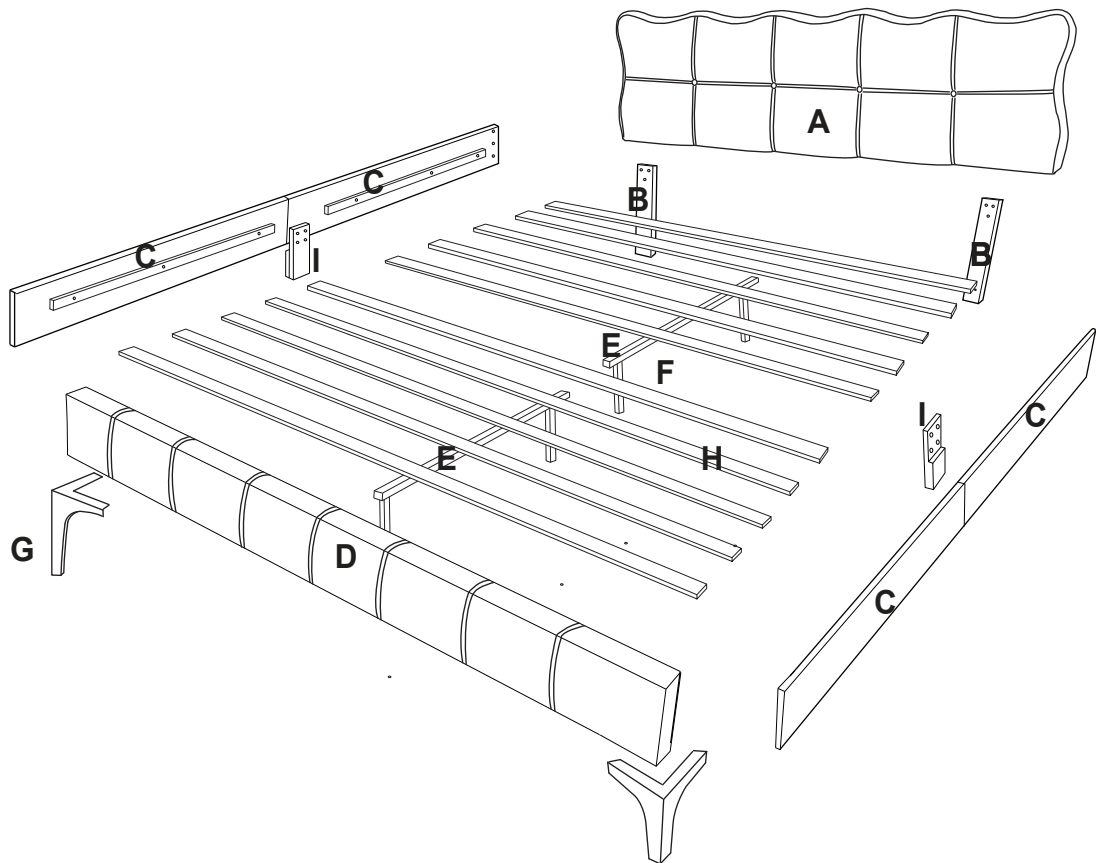

Detailansicht - WAVE BED





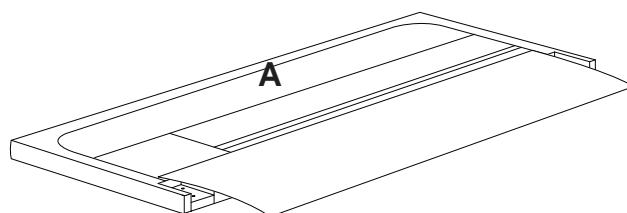

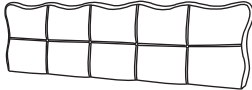
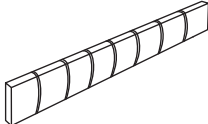

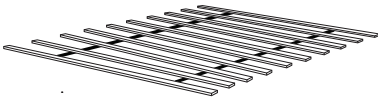

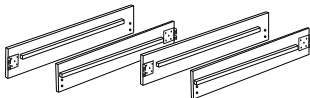
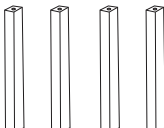
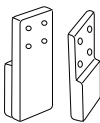
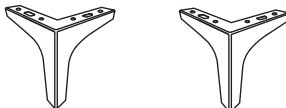

Bed Parts are shipped inside a compartment
in the back of the headboard .

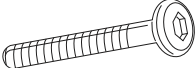
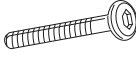
Bettteile werden in einem Fach auf der
R ü ckseite des Kopf- geliefert .

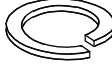

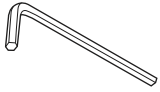
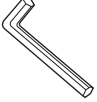
NO	PART LIST / TEILELISTE (BOX 1 OF 2) WF 314361/WF314363	QTY
A	Headboard/Kopfbrett 	1 pc/stk
D	Footboard/Trittbrett 	1 pc/stk
E	Center Support Rail/Mittlere St ü tzschiene 	2 pcs/stck
H	Bed Slat/Lattenrost 	12 pcs/stck

NO	PART LIST / TEILELISTE (BOX 2 OF 2) WF 314362/WF314364	
B	Headboard Leg/Kopfteil-Bein 	2 pcs/stck
C	Side Rail/Seitengitter 	4 pcs/stck
F	Center Support Leg/Mittleres St ü tzbein 	4 pcs/stck
I	Side Rail Support/Halterung f ü r Seitengitter 	2 pcs/stck
G	Bed Leg/Bettbein 	2 pcs/stck

NO	HARDWARE LIST/HARDWARE-LISTE (BOX 2 OF 2) WF 314362/WF314364	QTY
1	JCBB M8 x 20mm 	8 pcs/stck
2	JCBC M6 x 60mm 	4 pcs/stck
3	JCBC M6 x 35mm 	6 pcs/stck
4	JCBC M6 x 25mm 	8 pcs/stck
5	Spring Washer M6 	6 pcs/stck
6	Flat Washer M6 	14 pcs/stck
7	Allen Key M4 	1 pc/stk
8	Allen Key M5 	1 pc/stk
9	Adjuster M6 	4 pcs/stck
10	CSK M4 x 20mm 	6 pcs/stck
11	CSK M4 x 30mm 	24 pcs/stck

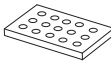
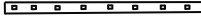
NO	HARDWARE LIST / HARDWARE-LISTE (BOX 2 OF 2) WF 314362/WF314364	QTY
12	Adapter 	1 pc/stk
13	Remote 	1 pc/stk
14	LED light 	1 pc/stk

Read this instruction carefully. Remove all wrapping material, staples and straps from the carton. See hardware and furniture part list for guidance. Be sure you have all wooden furniture parts on a clean and flat surface, such as carpet or rug, to prevent from being scratched.

Lesen Sie diese Anleitung sorgfältig durch. Entfernen Sie sämtliches Verpackungsmaterial, Heftklammern und Umreifungsbänder aus dem Karton. Siehe Beschläge und Möbel . Teileliste zur Orientierung. Stellen Sie sicher, dass Sie alle Holzmöbelteile auf einer sauberen und ebenen Oberfläche wie Teppich oder Teppich haben, um Kratzer zu vermeiden .

CAUTION :



1. Do not Full Tighten the nut or screw until all ready to assemble.
2. Do not Over Tighten the nut or screw to avoid causing damages to the thread.
3. Keep all hardware part out reach of children.

VORSICHT :

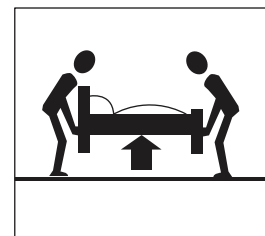
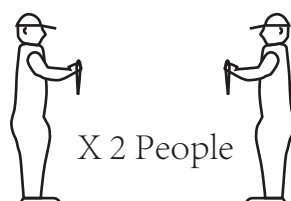
1. Ziehen Sie die Mutter oder Schraube nicht vollständig fest, bis alles zur Montage bereit ist.
2. Ziehen Sie die Mutter oder Schraube nicht zu fest an, um Schäden am Gewinde zu vermeiden.
3. Bewahren Sie alle Hardwareteile außerhalb der Reichweite von Kindern auf.



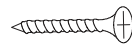

STEP 1

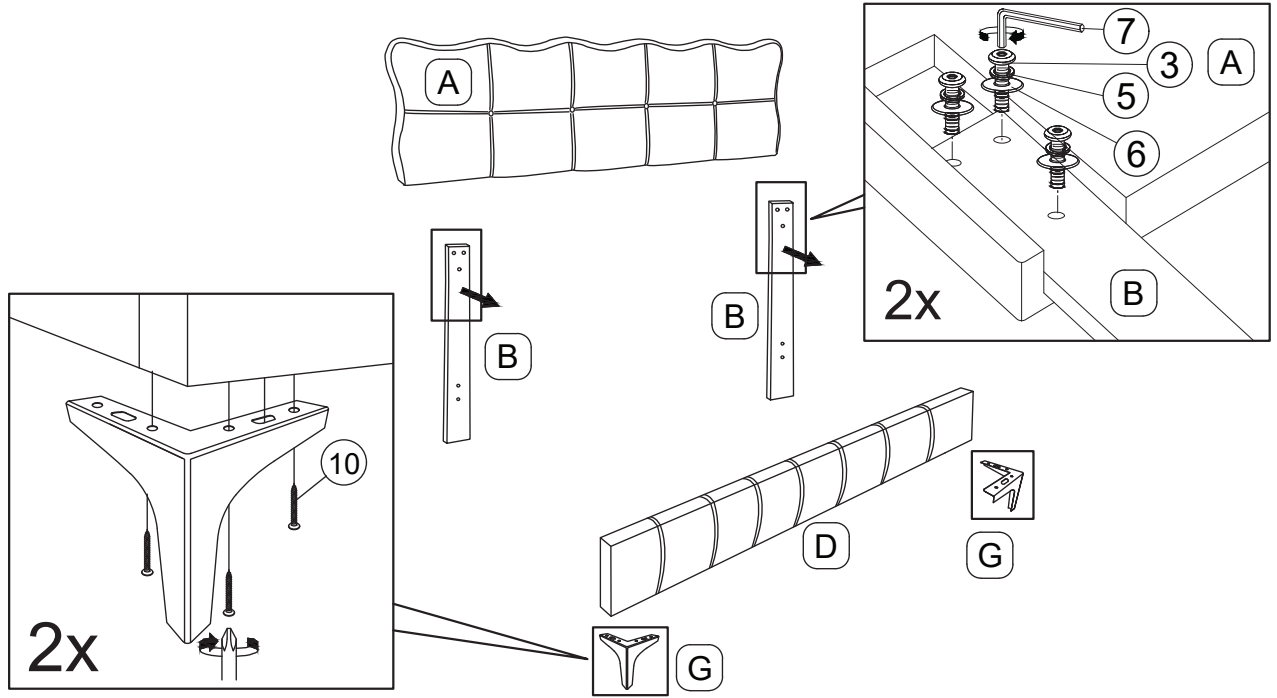
3	10	6	5
			
- 6 pcs/stck	20 pcs /stck	6 pcs/stck	6 pcs/stck



STEP 2

4	6
	
8 pcs/stck	8 pcs/stck

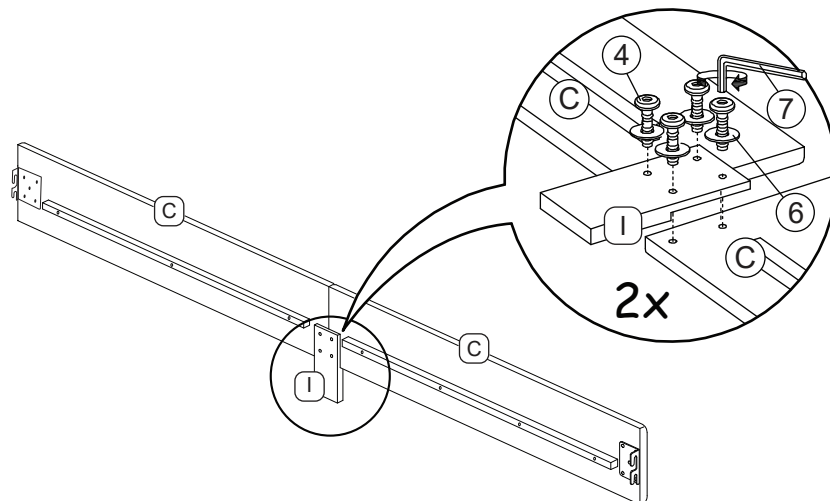

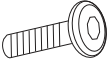

STEP 3

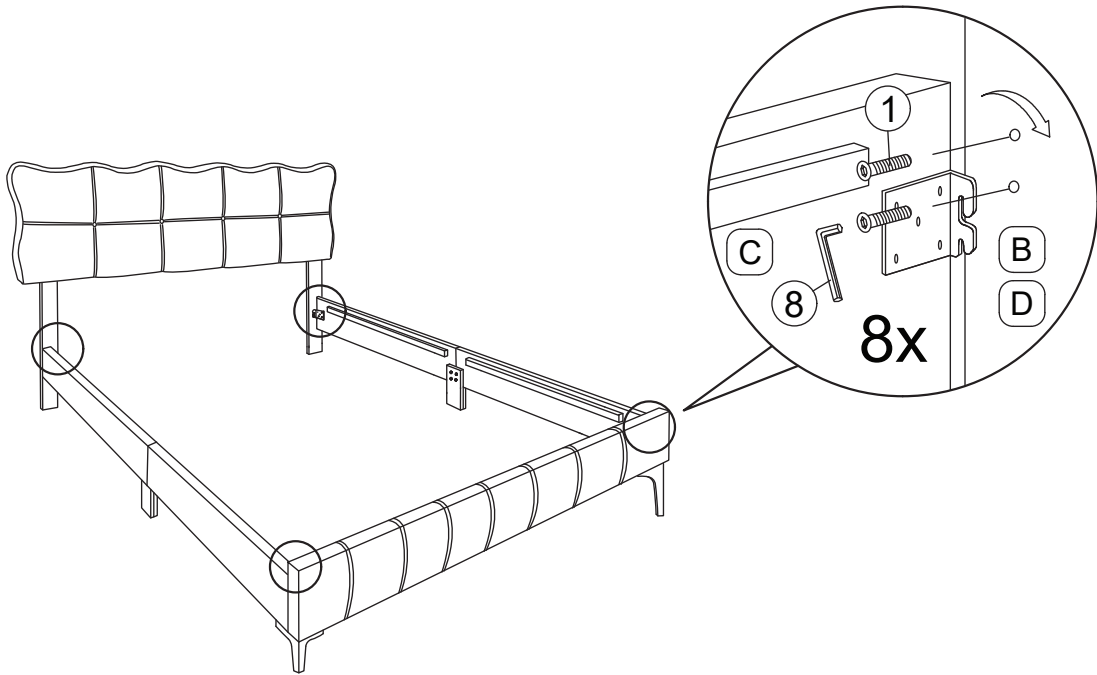
1

8 pcs/stck

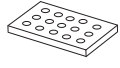

STEP 4

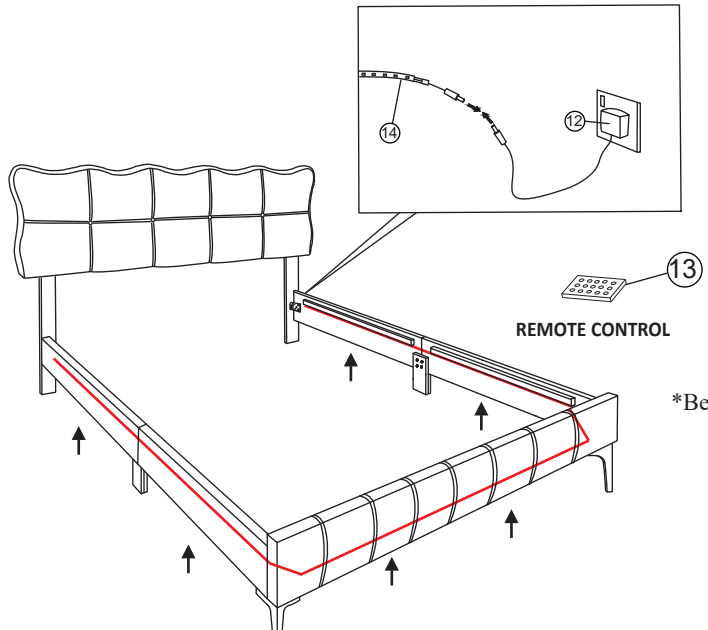

12	13	14
		
1 pc /stk	1 pc /stk	1 pc /stk



*Attach the velcro side of the LED light to the corresponding velcro tape under the slat support and footboard.

*Befestigen Sie die Klettseite der LED-Leuchte an der entsprechenden Klettband unter dem Lattenrost und dem Trittbrett.

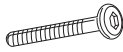
STEP 5

2	9
	
4 pcs/stck	9 pcs/stck

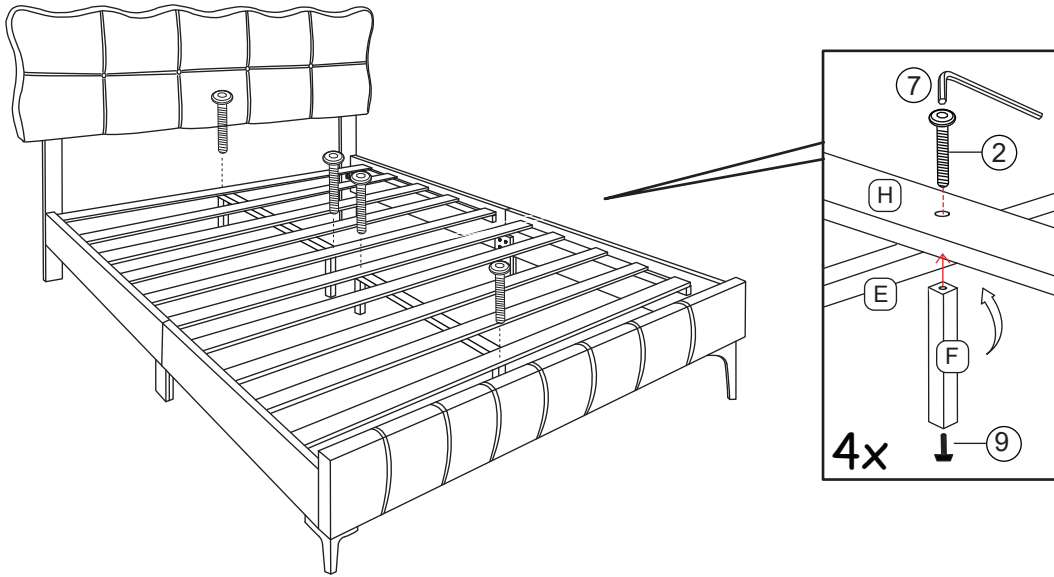

STEP 6

11

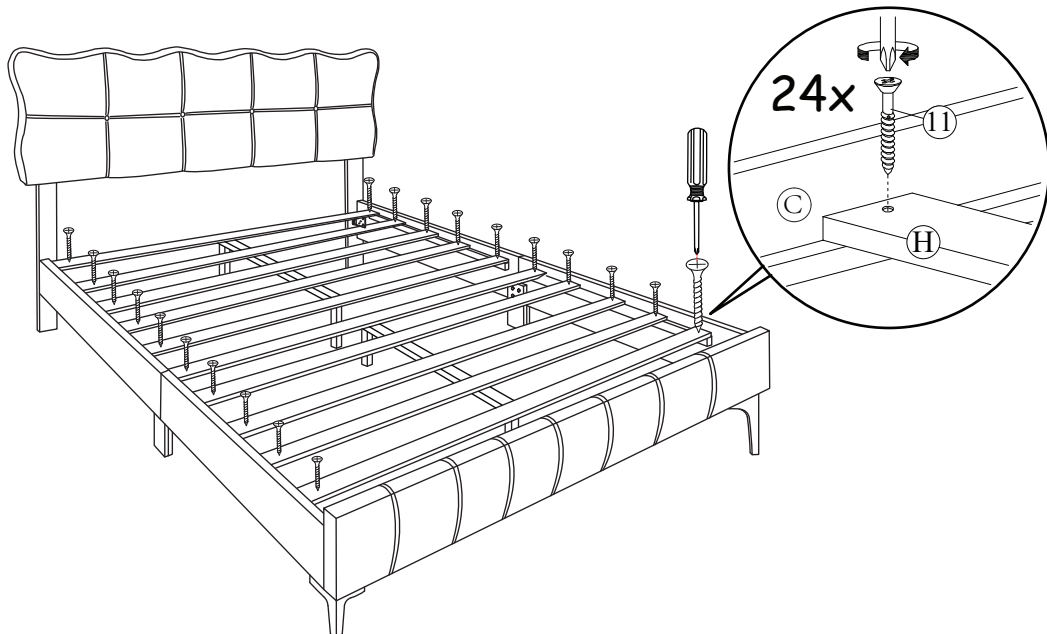
24 pcs/stck

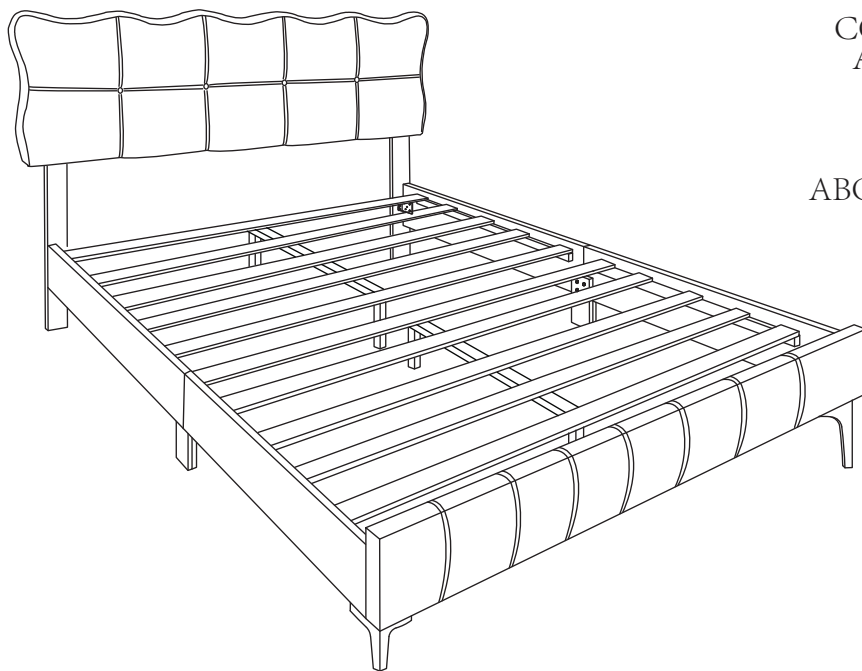



COMPLETED
ASSEMBLY

ABGESCHLOSSENE
MONTAGE