

ANLEITUNG

SKU: WF302666

TIPPS

1. Wir danken Ihnen für den Einkauf! Wir bemühen uns, Ihnen qualitativ hochwertige Produkte zu bieten. In seltenen Fällen, dass Ihr Produkt beschädigt ist, Teile fehlt oder Sie auf Probleme bei der Montage stoßen, wenden Sie sich damit bitte an unseren Kundendienst, wir werden Ihnen die beste Lösung so schnell wie möglich bieten. Um Ihr Problem schnell zu lösen, bitte stellen Sie uns einige Bilder zur Verfügung, die das Produktproblem deutlich widerspiegeln können. Vielen Dank !

2. Setzen Sie die Schrauben in die Löcher ein und ziehen Sie die Schrauben an, aber nicht zu fest, 70 % ~ 80 % ist genug, und ziehen Sie schließlich alle Schrauben an. Wenn einige Schrauben nicht mit den Löchern ausgerichtet sind oder die Montage einiger Teile schwierig ist, stellen Sie bitte den Straffheitsgrad der Schrauben um.

3. Es wird empfohlen, dass 2 Personen das Produkt installieren.

ANLEITUNG

SKU: WF302666





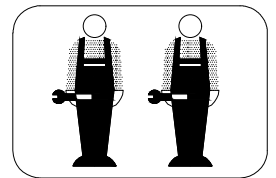
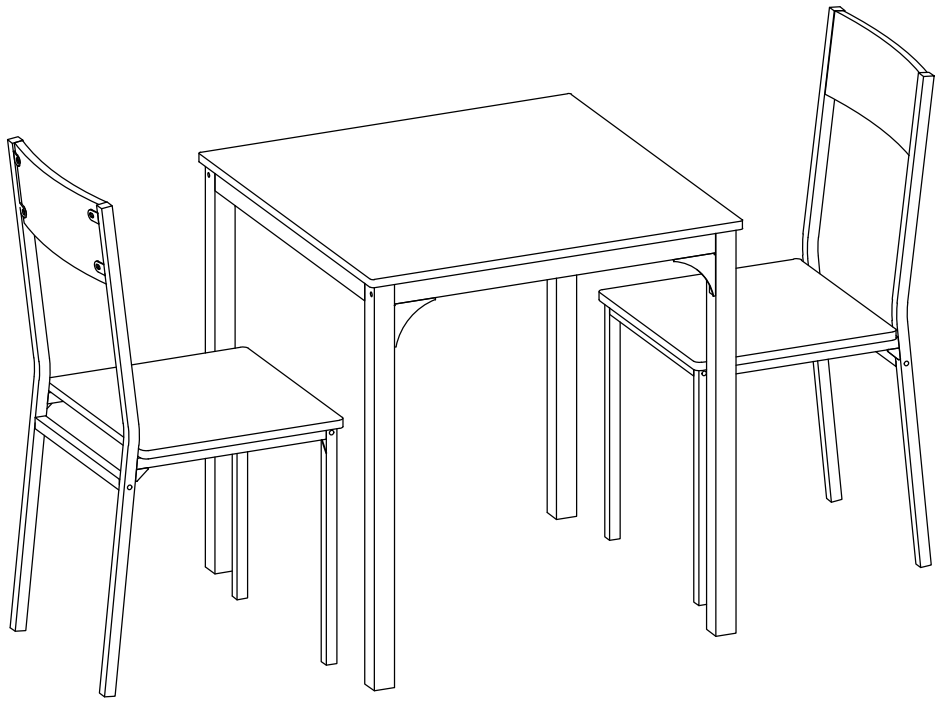

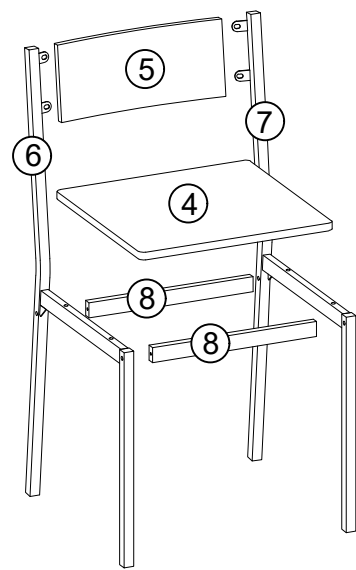
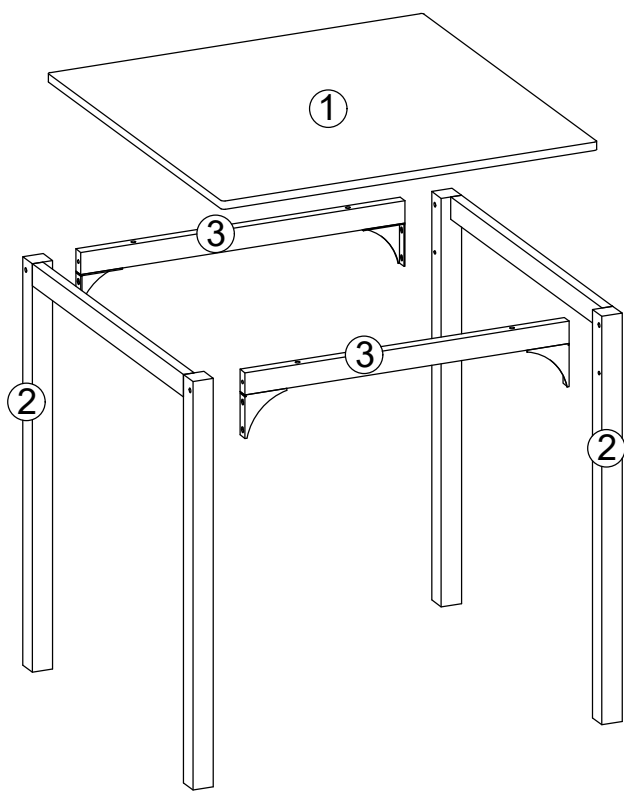
TIPS

1. Please read the instructions fully before assembly. These instructions include important information which could ensure correct assembly. We have been working on providing high quality products for you. However, in the rare instance that your product is defective, missing parts or there are some issues, please don't hesitate to contact our customer service to submit parts requirements, assembly suggestion, or warranty claims, and we will give the best solution as soon as possible. If necessary, we need you to provide some more clear pictures of the issue.
2. Insert the screws in holes and tighten the screws, but not too tight, 50% is ok, finally tighten all the screws. If some issues happened that some screws can not target to the hole or some parts are difficult to install, please adjust the tightness of the screws.
3. 2 people are recommended to finish

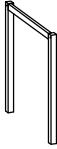





Teilelist

			
①×1pc	②×2pcs	③×2pcs	④×2pcs
			
⑤×2pcs	⑥×2pcs	⑦×2pcs	⑧×4pcs

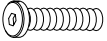
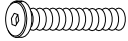
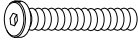
Hardwarelist

				
M6×12mm	M6×40mm	M6×50mm	M6×55mm	M4
Ⓐ×12pcs	Ⓑ×16pcs	Ⓒ×4pcs	Ⓓ×4pcs	Ⓔ×1pc

Schritt 1



M6×40mm

ⓑ×8pcs

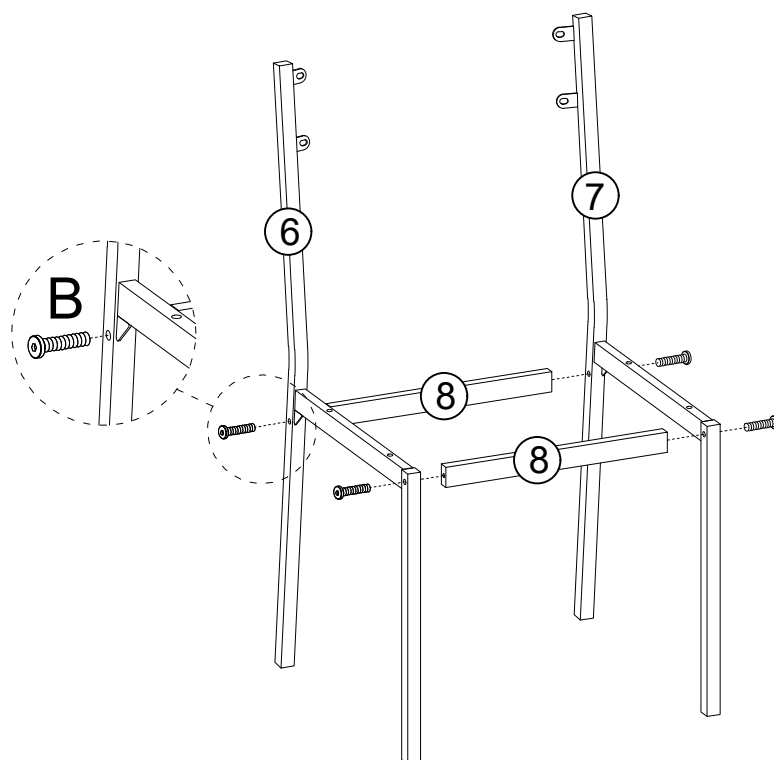

×2

Schritt 2



M6×40mm

ⓑ×8pcs

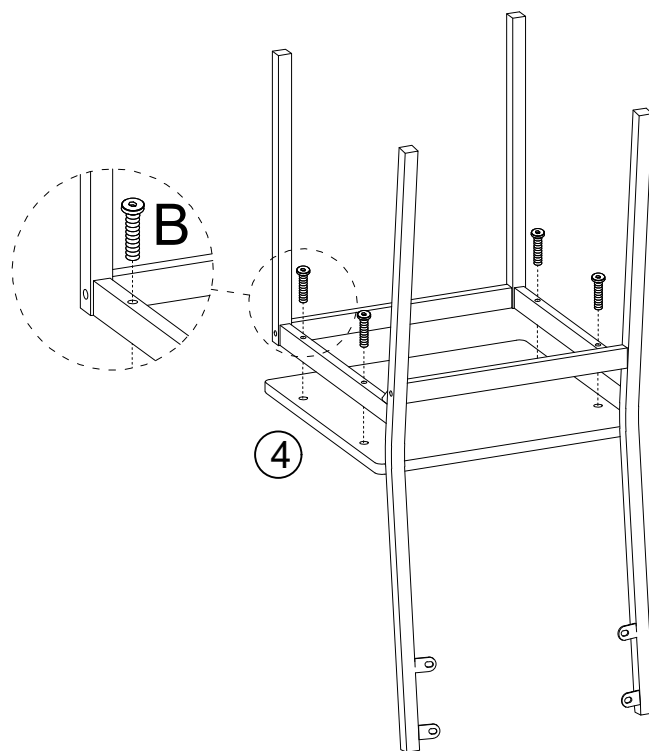

×2

Schritt 3



M6×12mm

Ⓐ ×8pcs

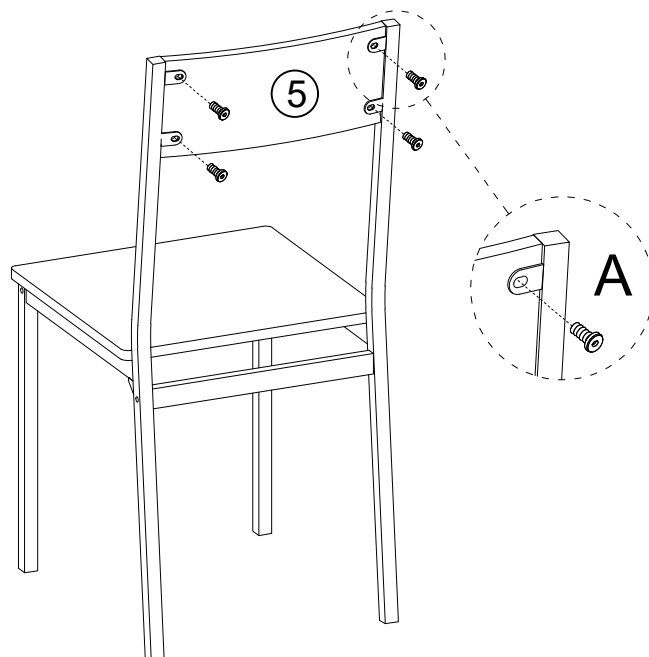

×2

Schritt 4



M6×12mm

Ⓐ ×4pcs

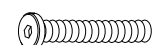

M6×55mm

Ⓓ ×4pcs

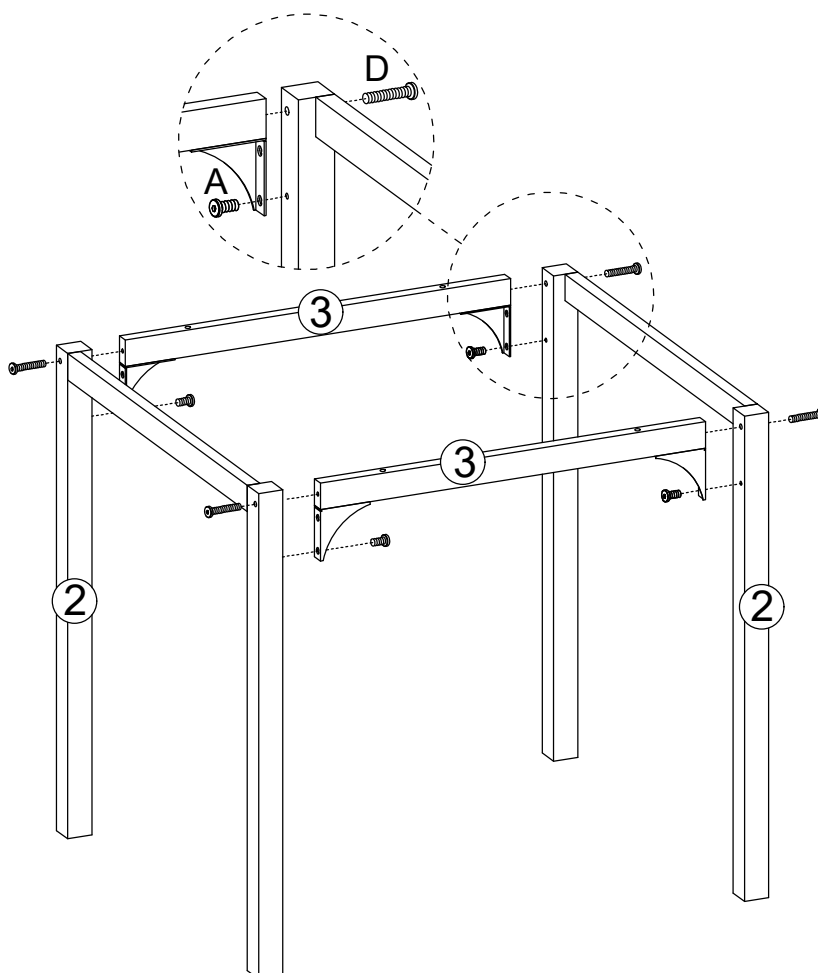

Schritt 5

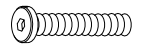

M6×50mm

Ⓒ ×4pcs

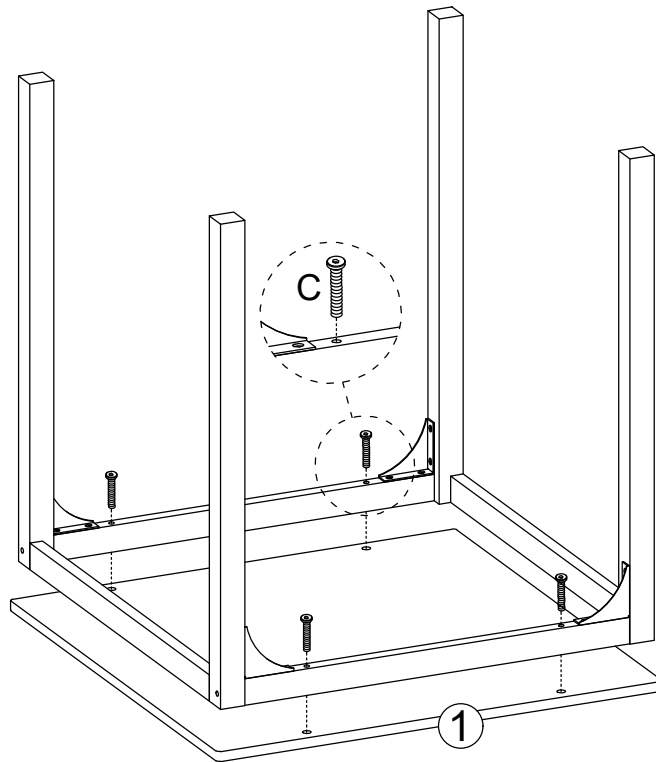

Schritt 6

