

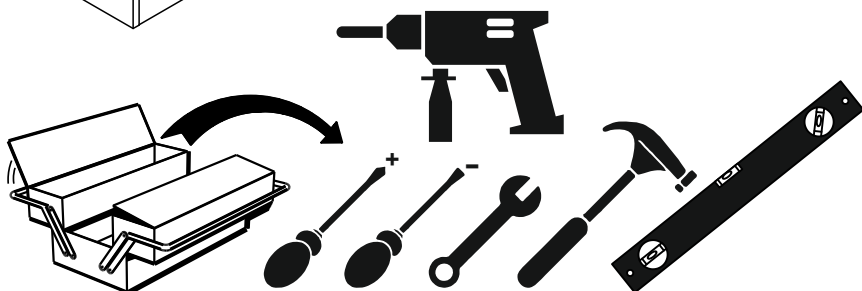

MULTIMO

114-ACADEMY

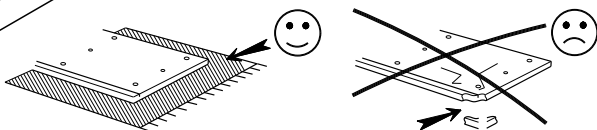
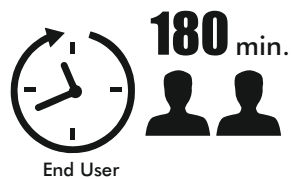
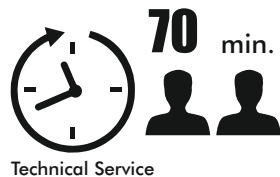
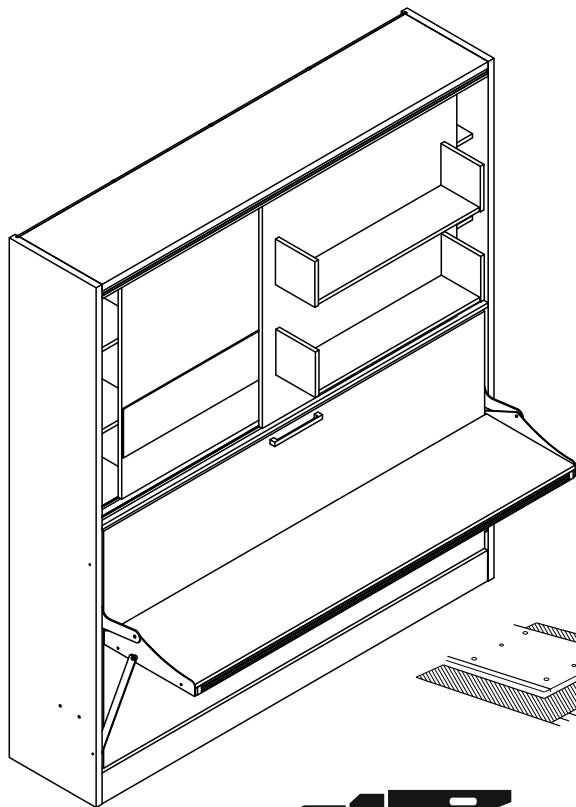

VIDEO











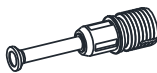



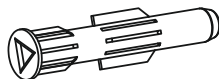
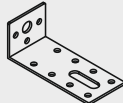

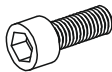
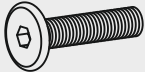

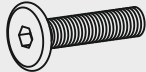

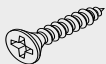
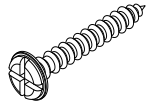
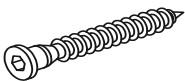

<https://youtu.be/IDPEdERmUyM>

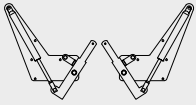
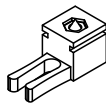
Assembly Instructions

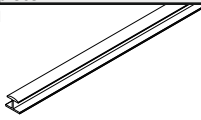
Track Title	Piece	(inch)			(mm)			
		Thickness	Length	Width	Piece	Thick	Height	Most
A-R / A-L		1,18	81,89	17,32	2	30	2080	440
B		1,18	77,01	16,54	1	30	1956	420
C		0,71	77,01	16,54	1	18	1956	420
D		0,71	77,01	16,54	1	18	1956	420
E		0,71	36,54	13,15	2	18	928	334
F		0,71	36,54	13,15	1	18	928	334
G		0,71	77,01	5,31	1	18	1956	135
H		0,71	75,75	17,72	1	18	1924	450
K		0,71	42,76	4,72	3	18	1086	120
L		0,71	25,59	4,65	4	18	650	118
M		0,71	11,81	12,99	4	18	300	330
N		0,71	32,28	7,68	2	18	820	195
O		0,71	7,87	7,87	4	18	200	200
P		0,71	75,98	37,01	1	18	1930	940
R-1 / R-2		0,71	34,88	38,78	2	18	886	985
Y		0,31	81,06	19,33	4	8	2059	491

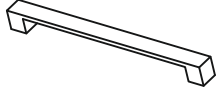
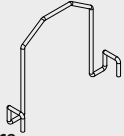
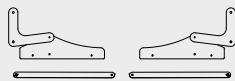
Accessories List

<p>MNX 02</p>  <p>42 / piece</p>	<p>MNG - 01</p>  <p>42 / piece</p>	<p>TAP - 01</p>  <p>42 / piece</p>	<p>KVL 01</p>  <p>64 / piece</p>
<p>VTB - 01 (4,8x16) mm</p>  <p>12 / piece</p>	<p>DD - 01 (R10)</p>  <p>3 / piece</p>	<p>DSE - 01 (40x90x32) mm</p>  <p>3 / piece</p>	<p>TFC - 01(8x70) mm</p>  <p>3 / piece</p>
<p>IM - 01 (6x30) mm</p>  <p>4 / piece</p>	<p>CT - 02 (6x30) mm</p>  <p>2 / piece</p>	<p>VKP - 01 (22) mm</p>  <p>2 / piece</p>	<p>CT - 01 (6x40) mm</p>  <p>6 / piece</p>
<p>SN - 01 (M6)</p>  <p>4 / piece</p>	<p>SG - 01</p>  <p>2 / piece</p>	<p>VD - 03 (3,5x18) mm</p>  <p>8 / piece</p>	<p>VD - 02 (3,5x25) mm</p>  <p>28 / piece</p>
<p>VDA - 01 (6,5x50) mm</p>  <p>6 / piece</p>	<p>OT-054</p>  <p>2 / piece</p>	<p>PL - 02 (8x22x1) mm</p>  <p>3 / piece</p>	<p>PM - 01</p>  <p>16 / piece</p>
<p>MKZ - 01E</p>  <p>1 / piece</p>	<p>STP - 01</p>  <p>4 / piece</p>	<p>AF - 01</p>  <p>4 / piece</p>	<p>OT-006</p>  <p>2 / piece</p>
<p>H 01</p>  <p>3 / piece</p>	<p>BO - 01</p>  <p>2 / piece</p>	<p>KP - 01 (224) mm</p>  <p>1 / piece</p>	<p>TTC 01</p>  <p>4 / piece</p>
<p>SC-32</p>  <p>2 / piece</p>	<p>PL - 01 (6x19x1) mm</p>  <p>4 / piece</p>	<p>AVT - 01</p>  <p>12 / piece</p>	

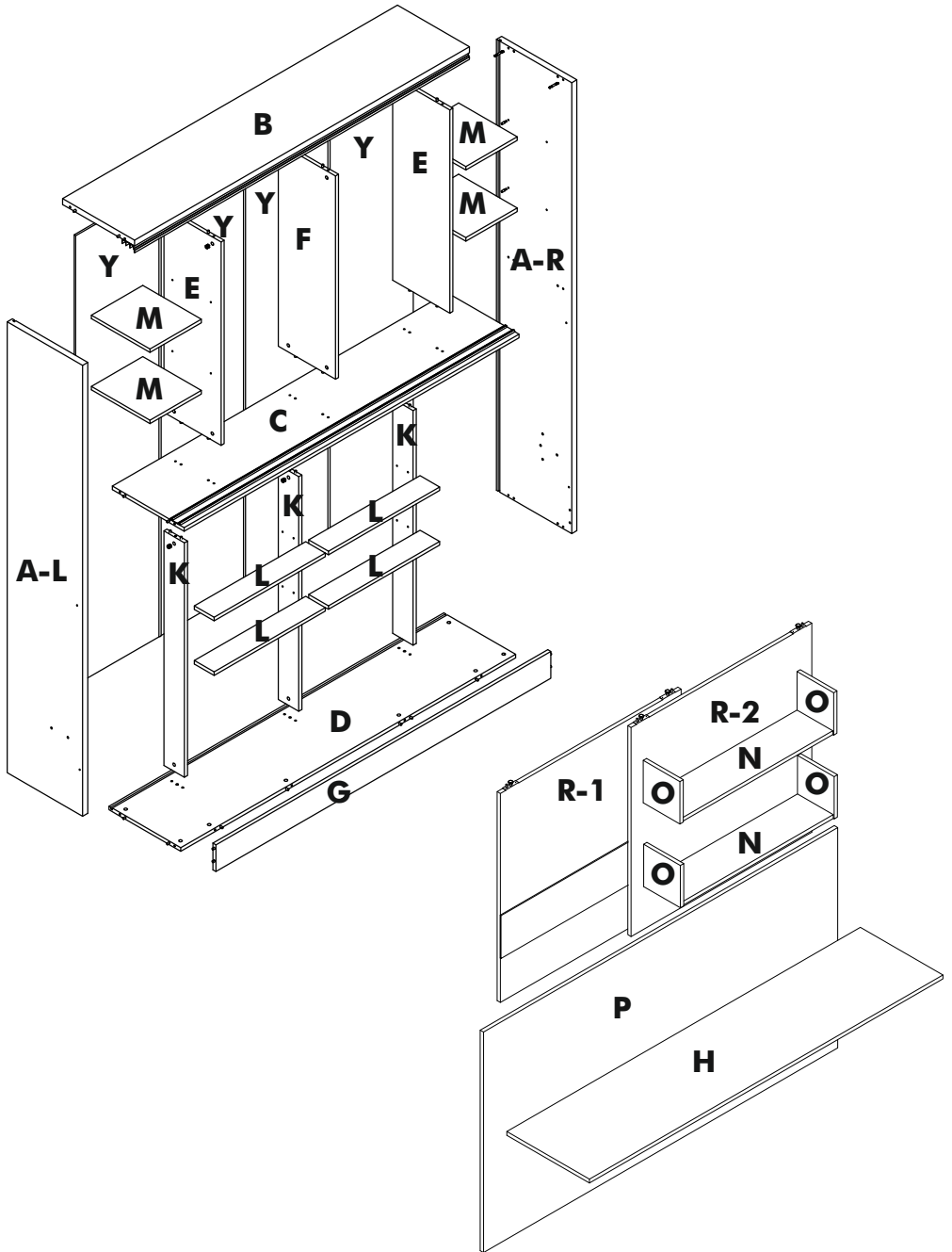

STEP 1

Rail should be disconnected before tighten MNX
After tighten MNX (STEP 11) rail can be connected

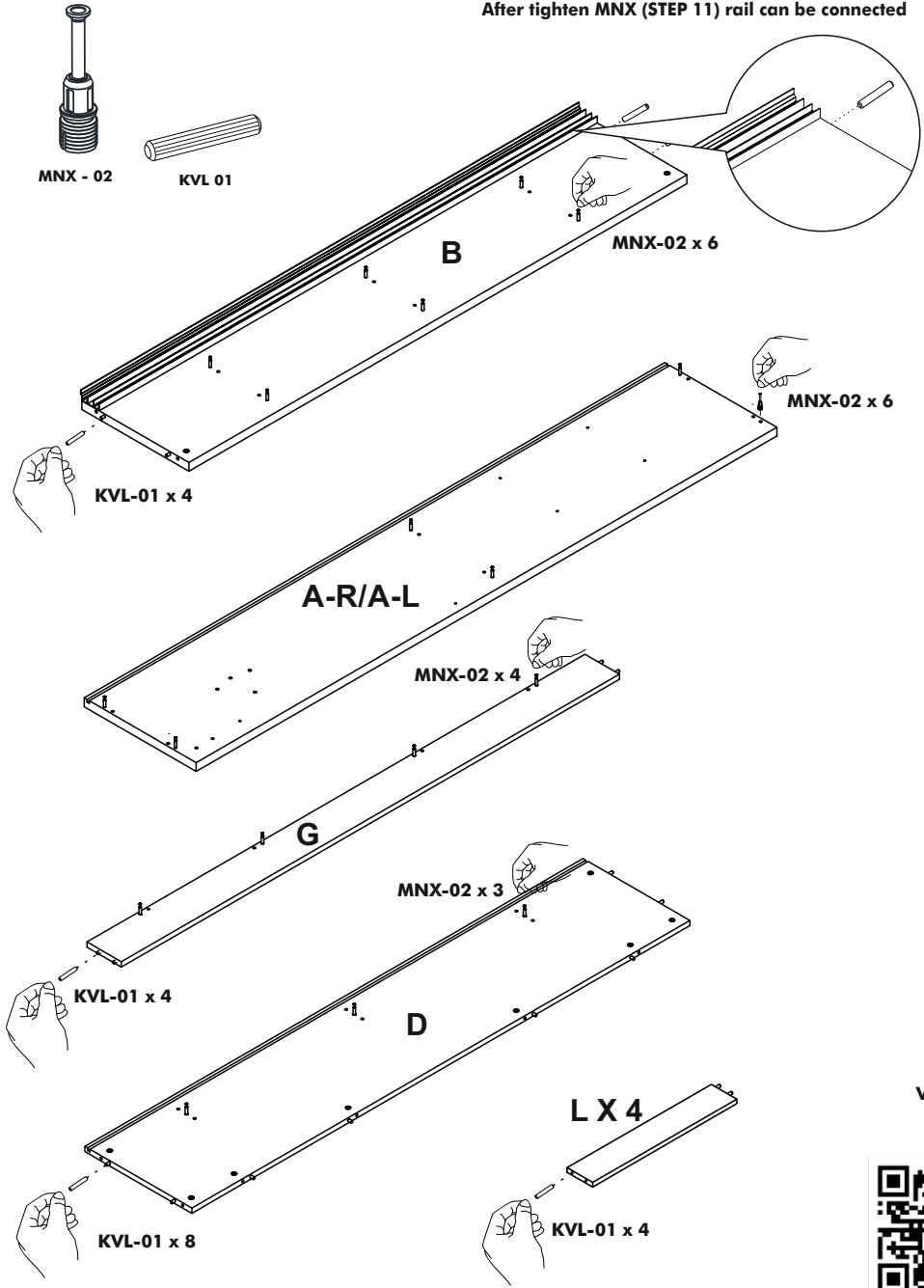

VIDEO



STEP 2

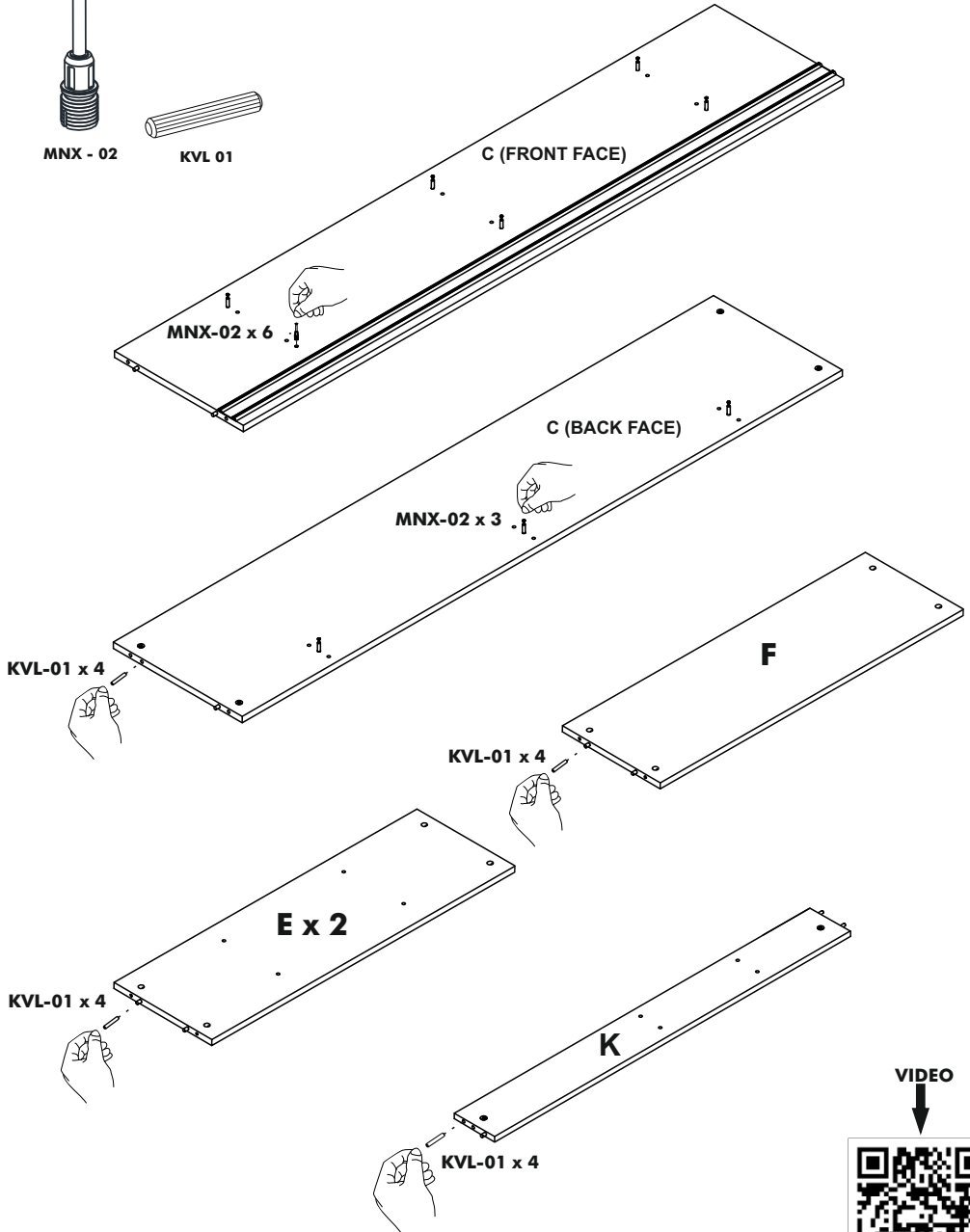
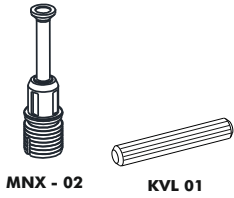

VIDEO



https://youtu.be/ManZIXfj_L4

STEP 3

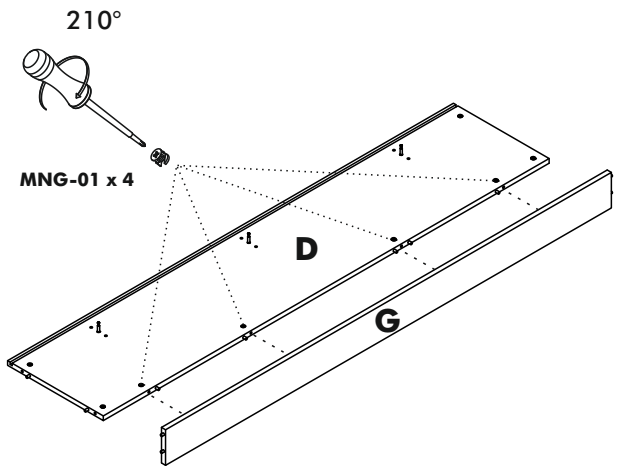

STEP 4

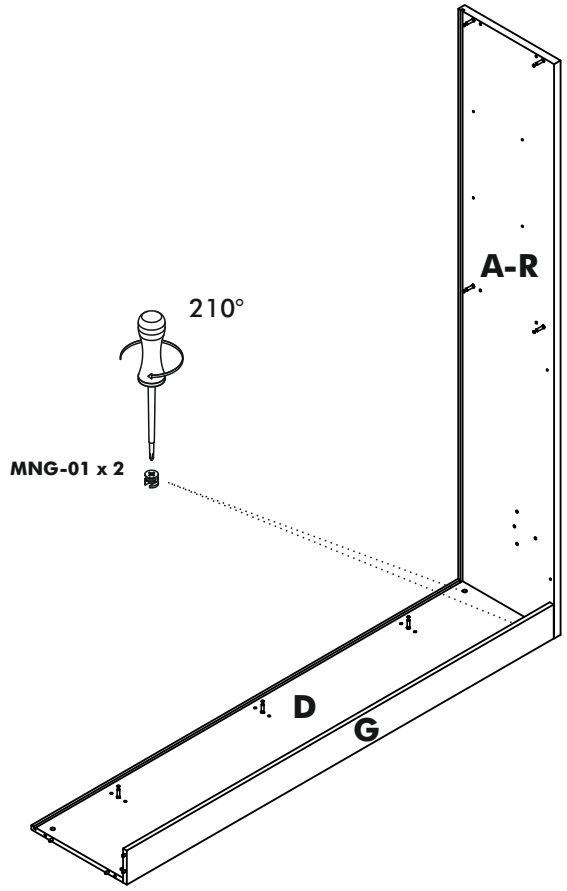

VIDEO



STEP 5



MNG - 01

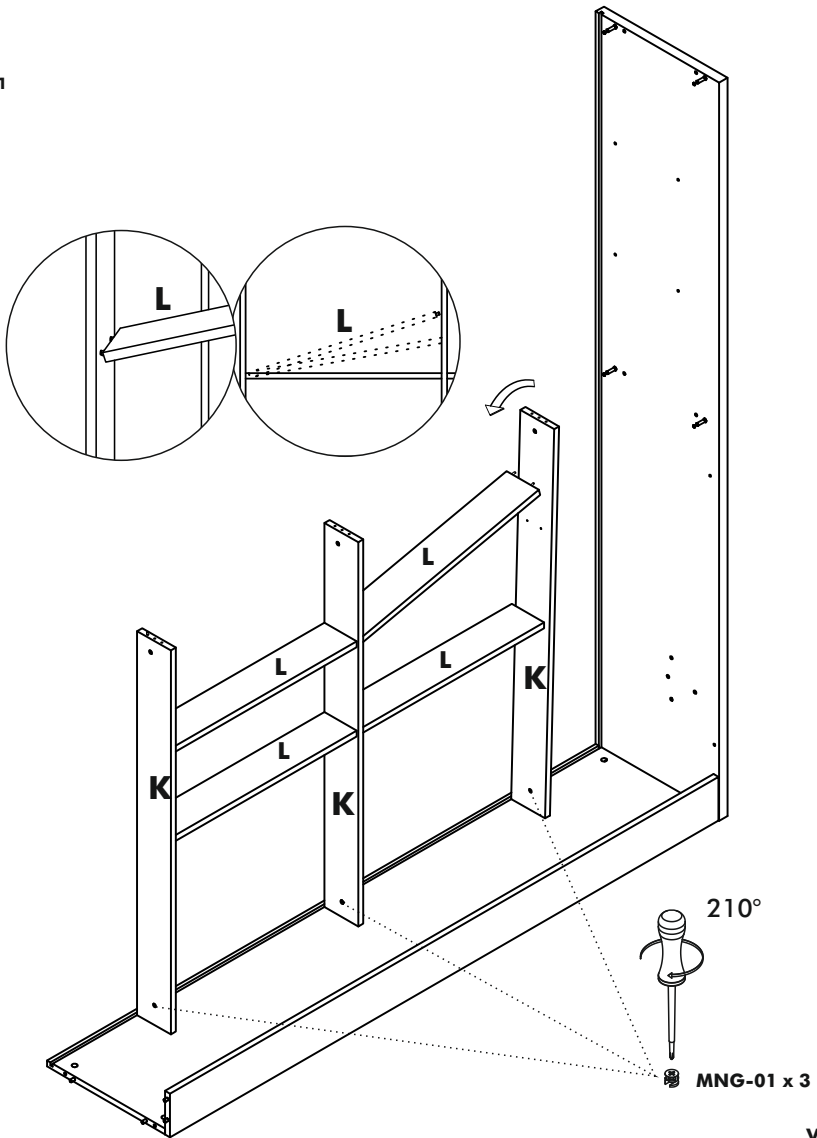

VIDEO



https://youtu.be/DeV_VegaTQs

STEP 6



MNG - 01

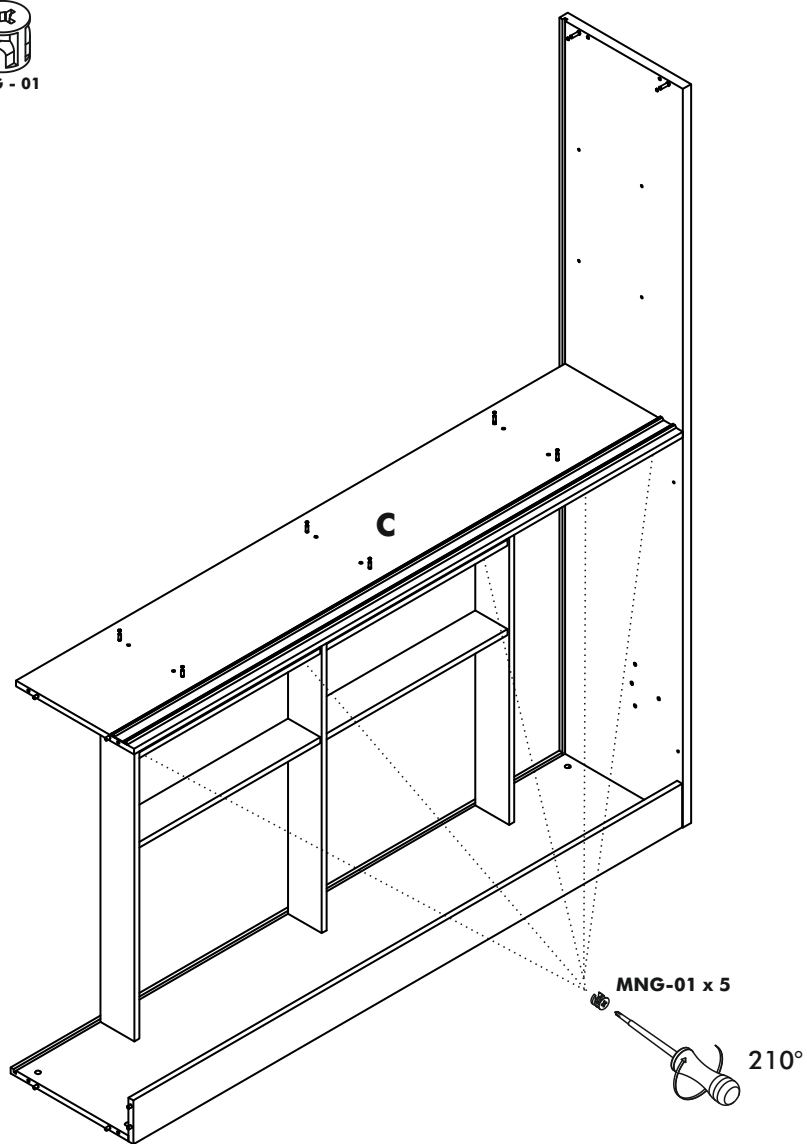

VIDEO



<https://youtu.be/LcrzlduSZKo>

STEP 7

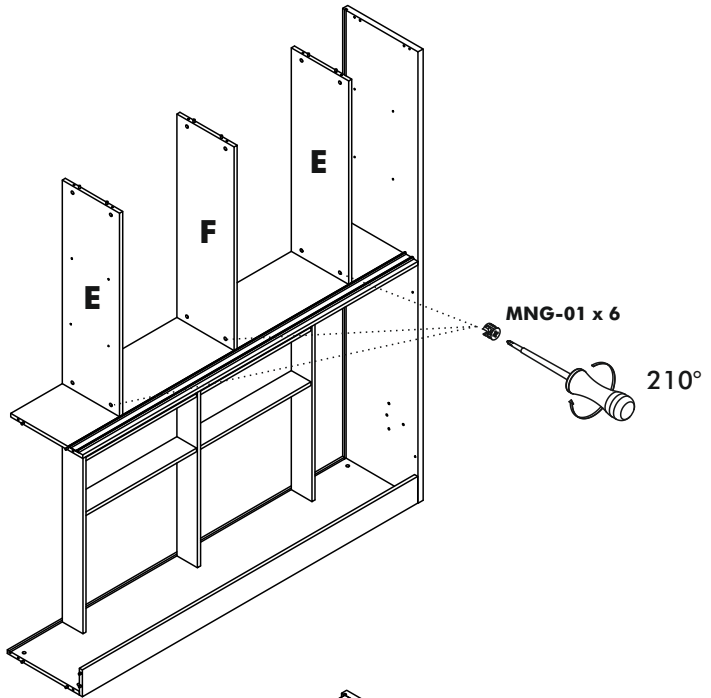

STEP 8

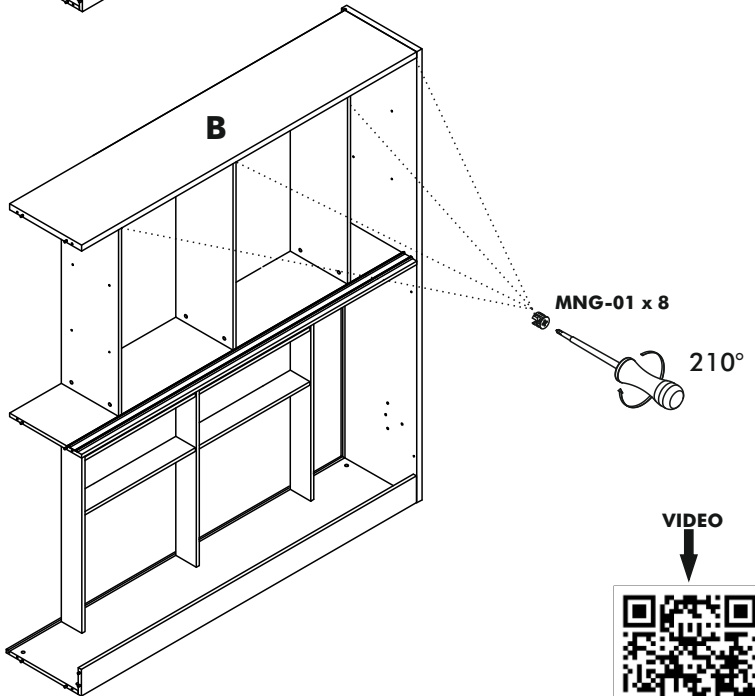

VIDEO



STEP 9

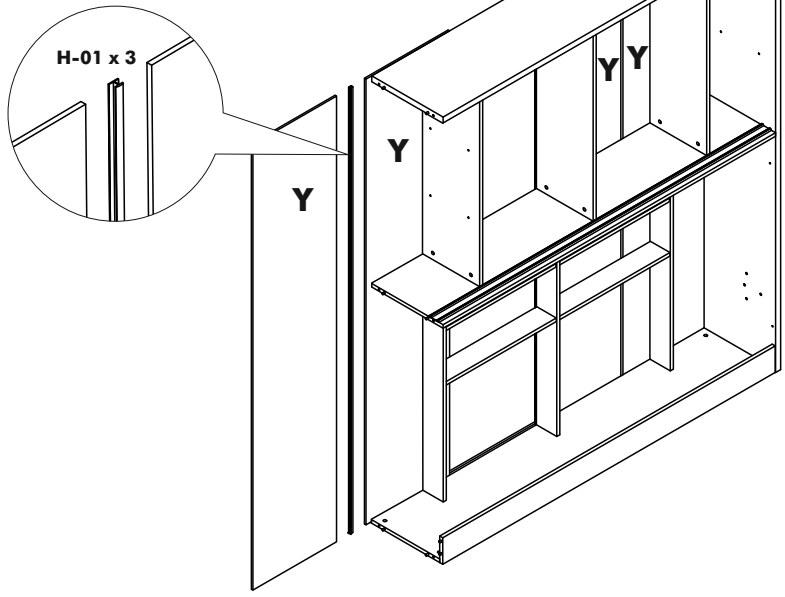

STEP 10

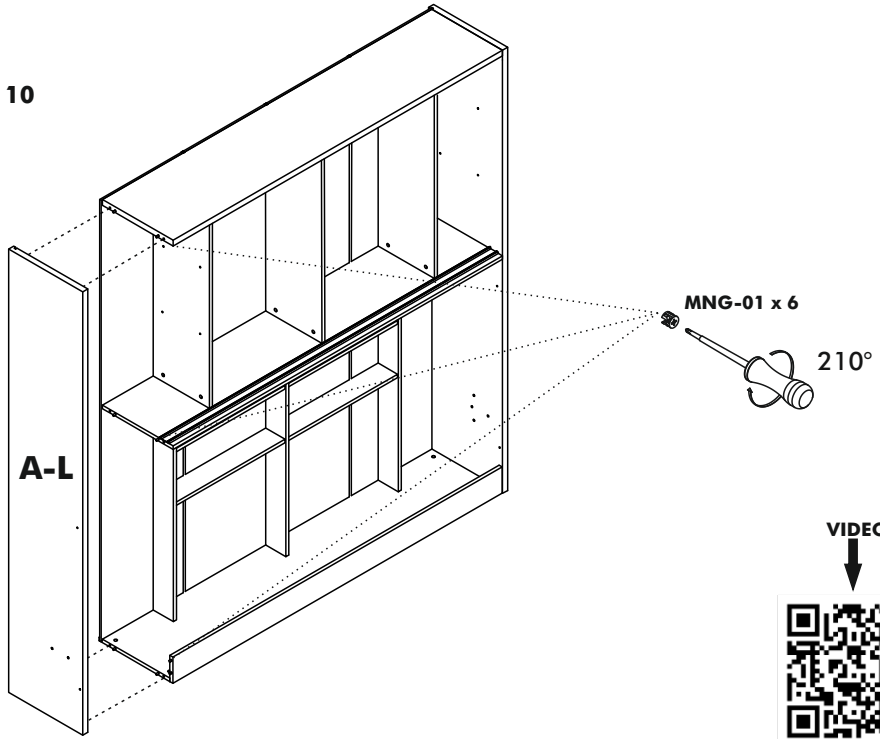

STEP 11

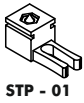

SPT-01

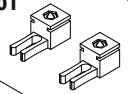

SPT-01

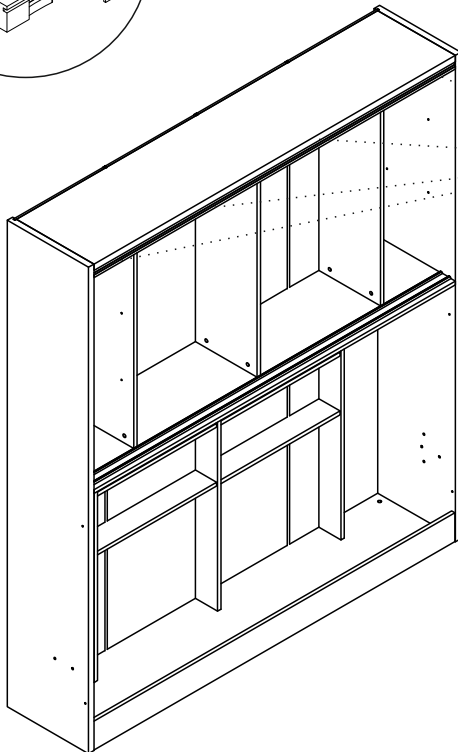
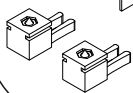

VIDEO



<https://youtu.be/aRYhpPNEar0>

STEP 12

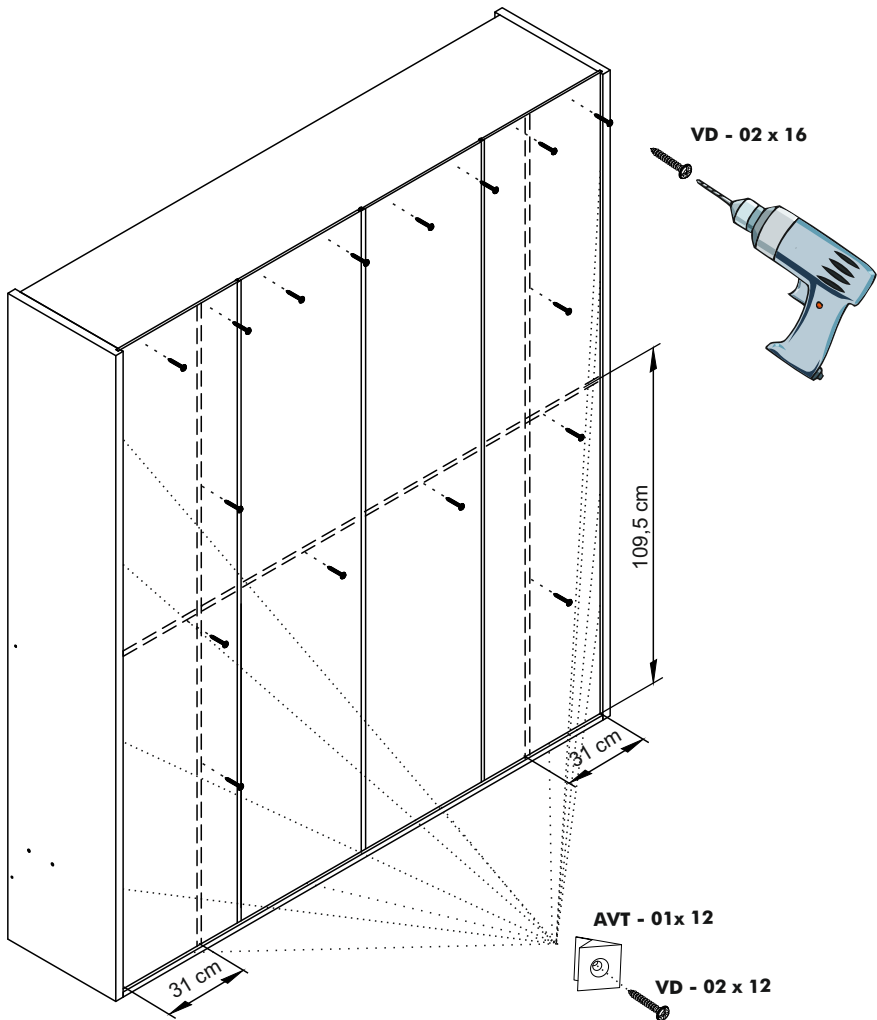

VIDEO



STEP 13

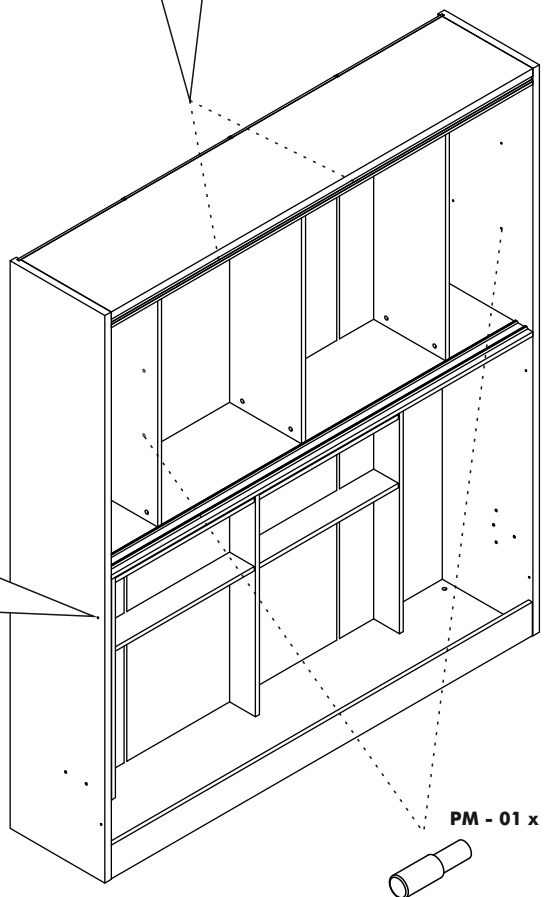
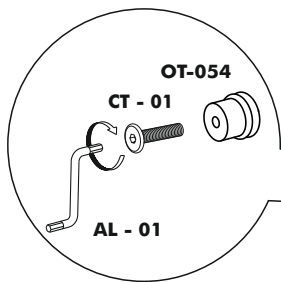
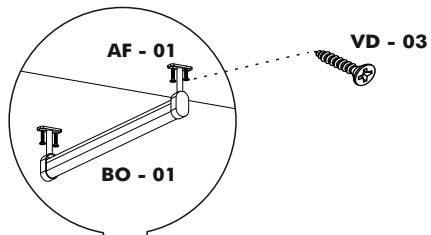

VIDEO



<https://youtu.be/3jGrQKVYGmU>

STEP 14

CAUTION
DO NOT UNLOCK BEFORE INSTALL

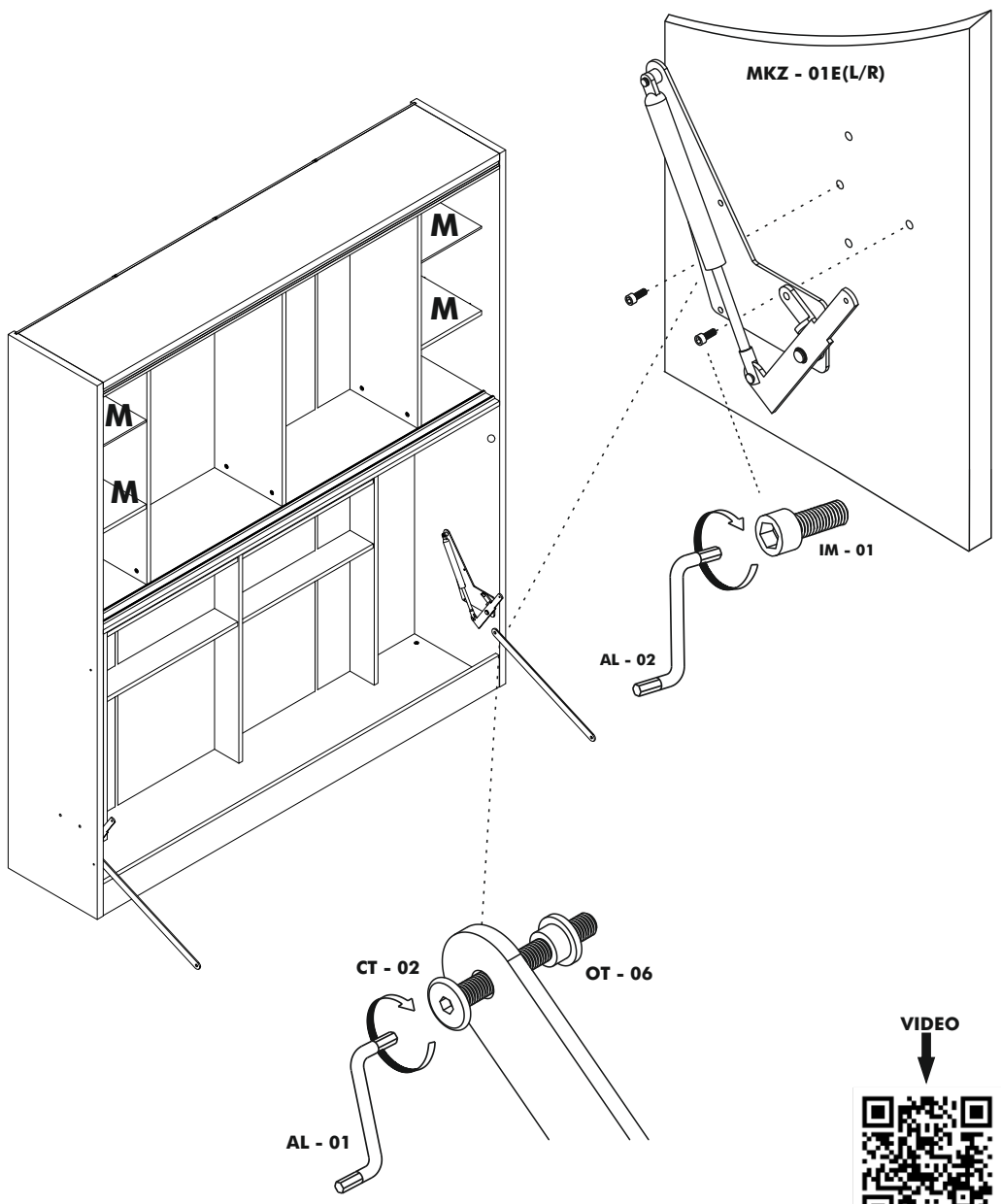

VIDEO



<https://youtu.be/LSPD0vw0puE>

STEP 15



Ø 10 mm / 0,254 inch

DD - 01

PL - 02

TFC - 01

VTB - 01

DSE - 01

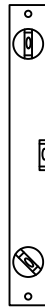
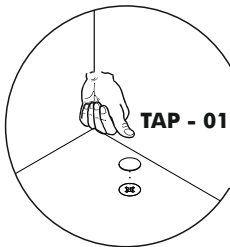

VIDEO



<https://youtu.be/iAF3UdvigHk>

STEP 16

45-50°

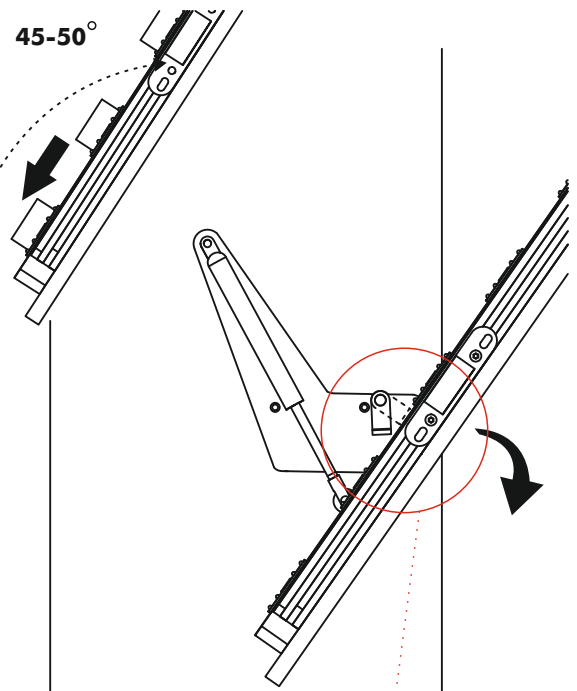
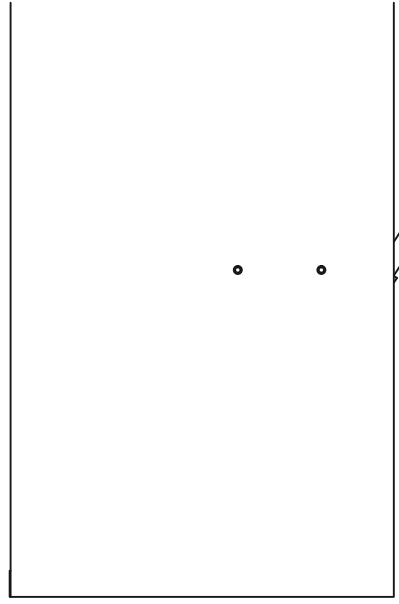

LET THE STOPPER LOCK MOVE DOWN !!!

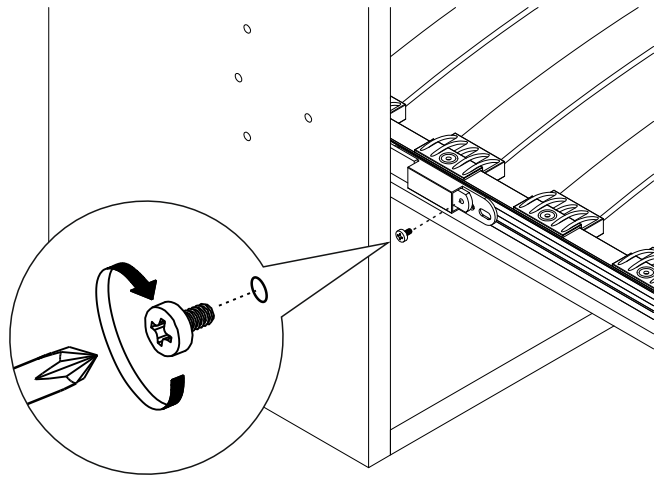
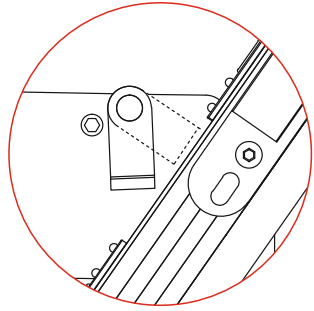

VIDEO



<https://youtu.be/YJZdWsGjBww>

STEP 17

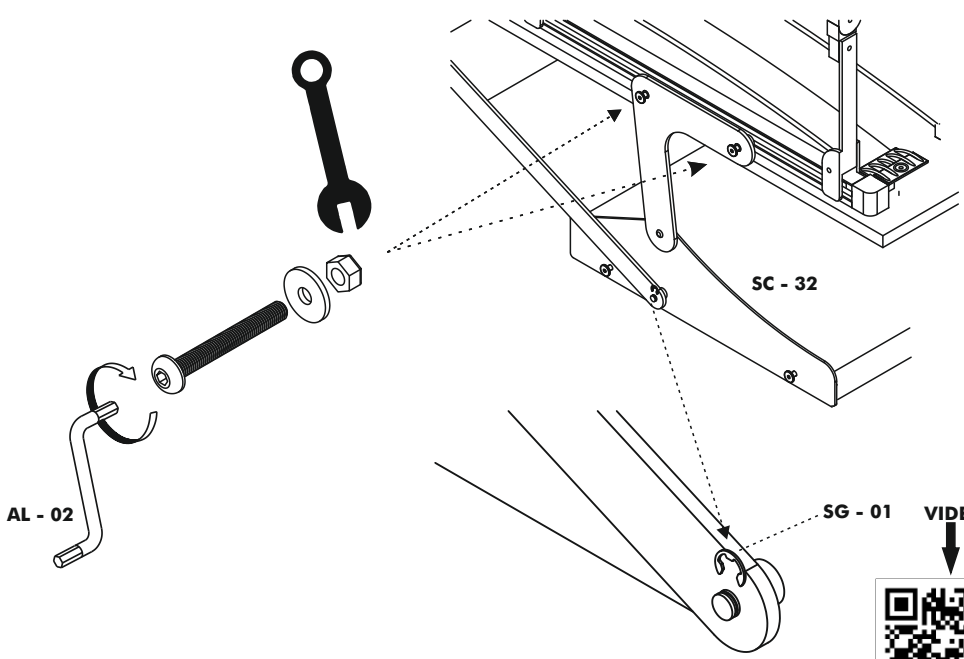
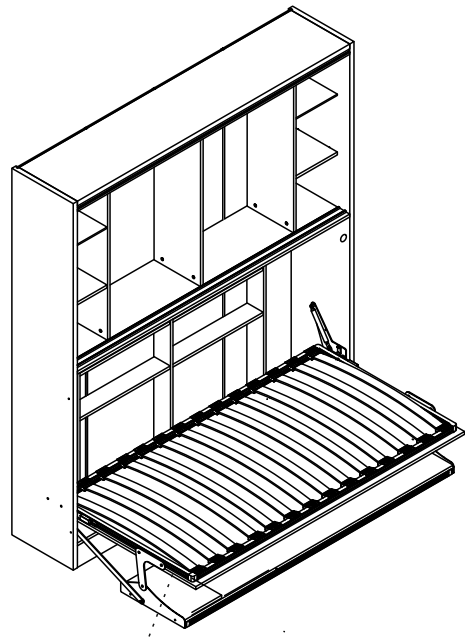
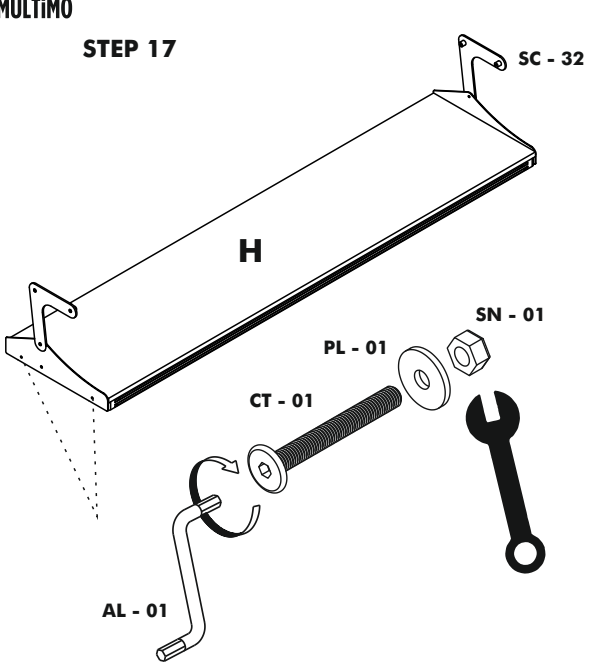

<https://youtu.be/5WnL9GPZSng>

STEP 18

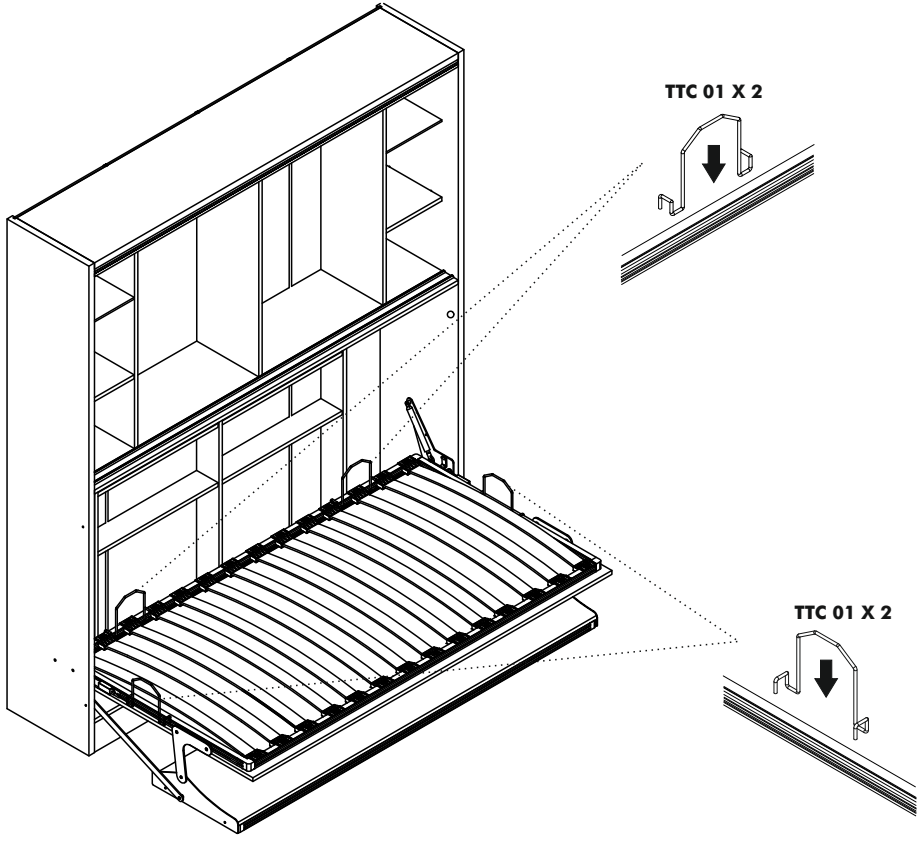

VIDEO



https://youtu.be/KgCUcve_Nel

STEP 19

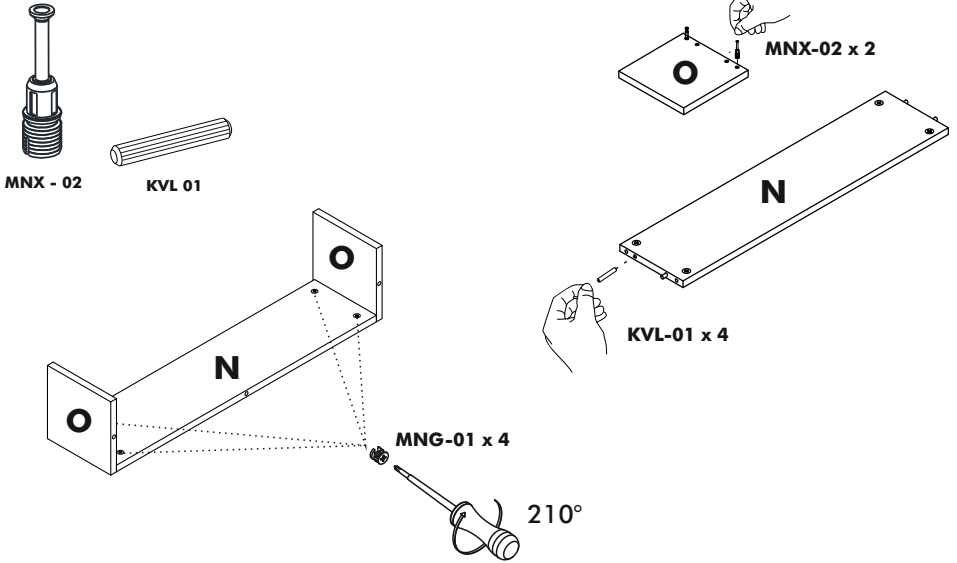

STEP 20

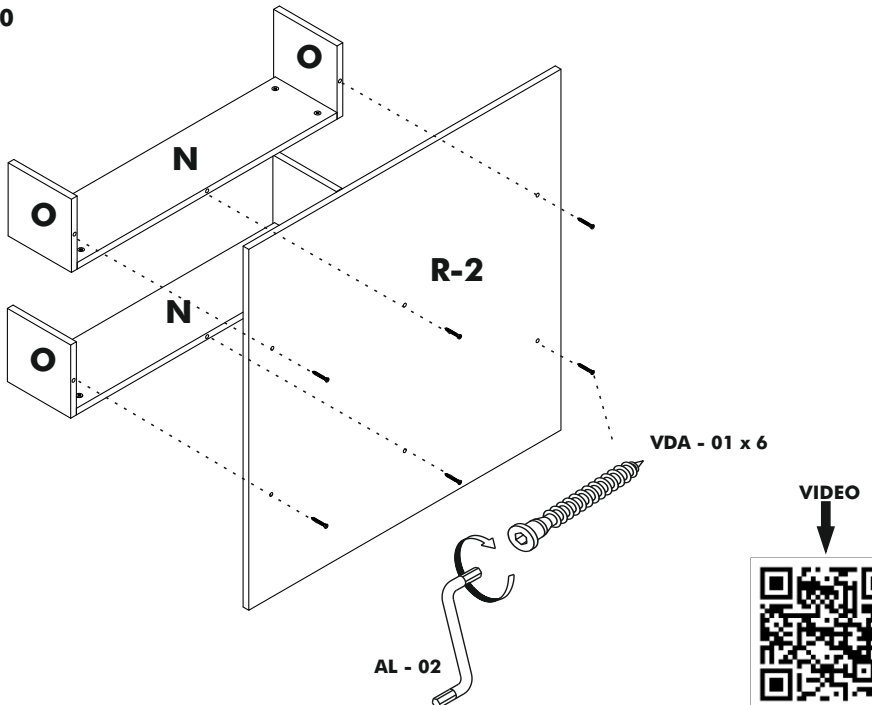

STEP 21

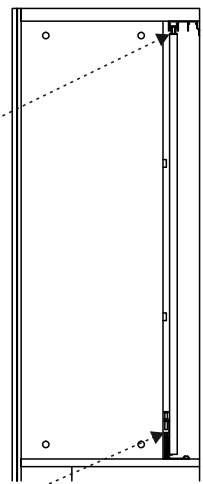
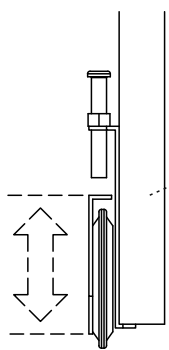
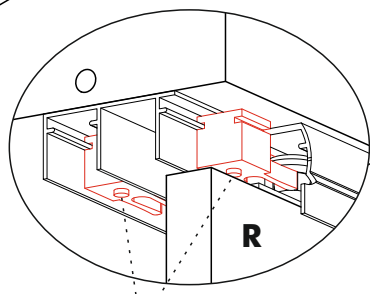
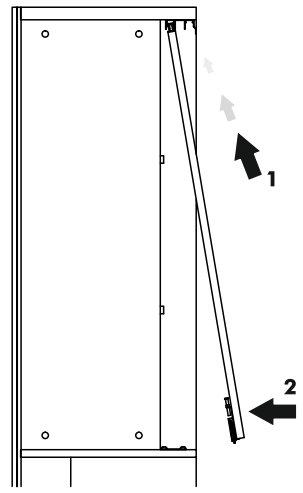
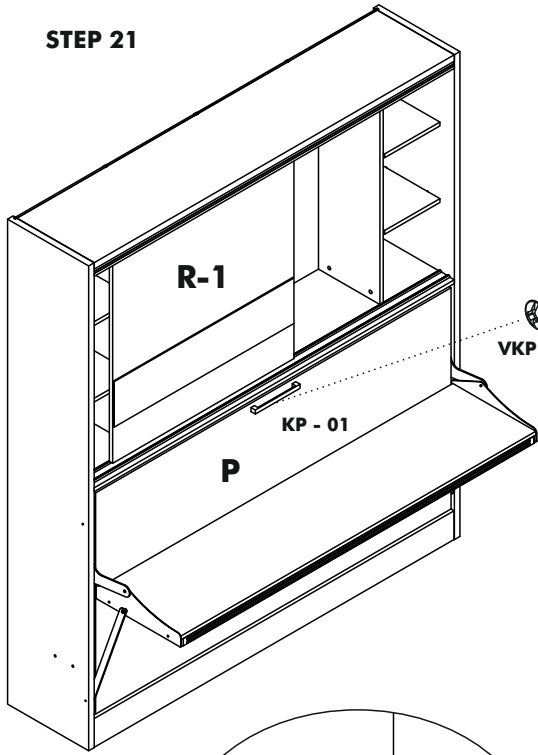

VIDEO



STEP 22

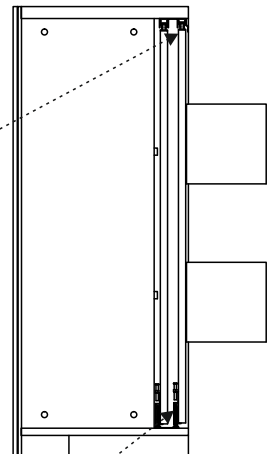
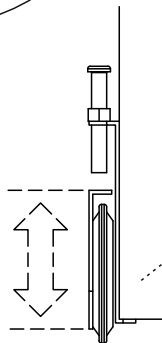
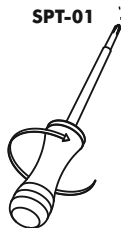
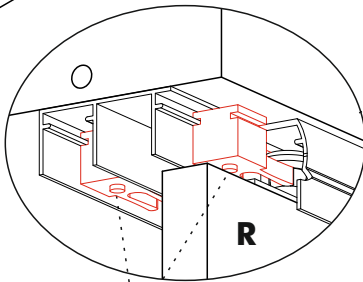
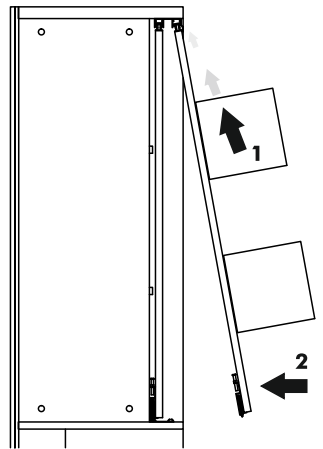
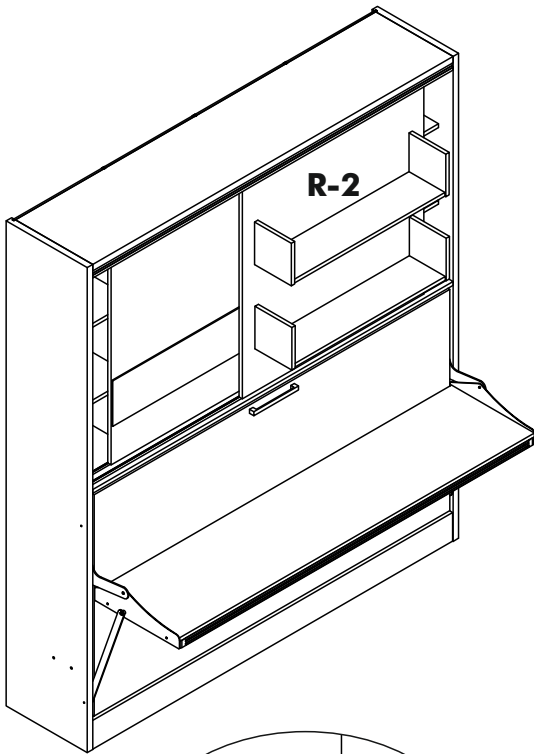

VIDEO



ATTENTION / HOW TO / READ ME / OWNER'S GUIDE

1. When mounting on a regular drywall, furniture must be fastened to wood or metal studs. Solid walls made of brick, concrete or similar strong material are also acceptable. Do not mount furniture to paper-mache or sheet rock like material without properly affixing to stud.
2. For safety and product longevity you must periodically inspect the mounting and mechanical connections for integrity and tightness. Confirm hardware remains properly affixed and connections snug.
3. Wall Bed mattress thickness may not exceed 8 inch. Take care to remove pillows and excess blankets before closing. Doing so keeps mechanism free of obstruction and unnecessary stress.
4. Do not lean or rest heavy objects on side or top of furniture. This may cause balance issues and compromise the integrity of your mounting connections.
5. Please use the furniture's beds, desks and shelving as intended. Not designed to be sat, stood, leaned, jumped (etc) on. Improper use may cause personal injury and damage to property.
6. With seasonal humidity change you must inspect interior and exterior of furniture.
7. Single, Twin, Twin XL beds accommodate the weight of one person. Improperly sleeping more than one person risks injury to person and damage to property.
8. Before any un-mounting or disassembly please contact Multimo for technical support and instruction. Failure to properly detach risks injury to person and damage to property.
9. For Bunk Beds:
 - a. Always use provided ladder when accessing top bunk.
 - b. Be slow, careful and aware of surroundings when opening top bunk.
 - c. Do not horseplay. Beds are to be slept on only.
 - d. Some have legs that fully extend when open- be aware of where the leg is and will be.



www.multimo.com