

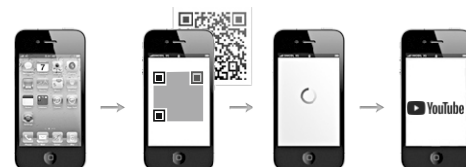

- | | | |
|---|--|--|
| (D) Videounterstützte Montageanleitung | (GB) Video-assisted assembly instructions | (FR) Instructions de montage assistées par vidéo |
| (TR) Video destekli kurulum talimatları | (IT) Istruzioni di montaggio video-assistite | (NL) Video-ondersteunde montage-instructies |
| (RU) инструкция по монтажу с помощью видеосигнала | (CZ) Instalační pokyny podporované videem | (HU) Video-támogatott telepítési utasítások |
| (RO) Instrucțiuni de instalare acceptate video | (PL) Instrukcje montażu wspomagane sygnałem wizyjnym | (SK) Inštaláčn  pokyny podporované videom |

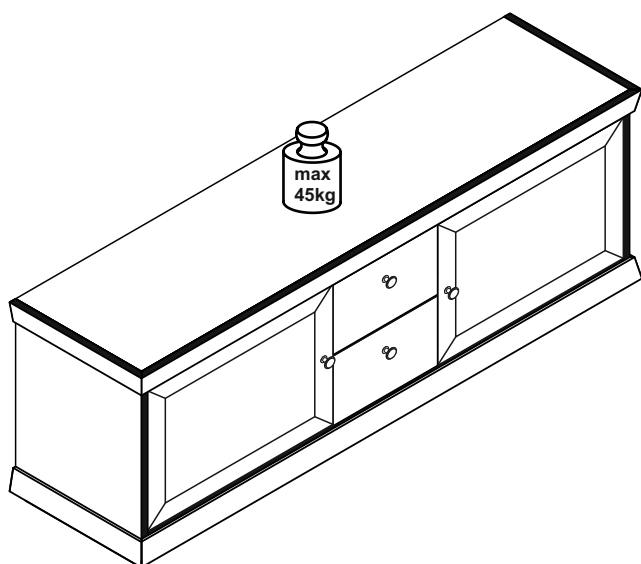

Art.-Nr.: **0630-LB_22-167**

Lowboard

REPC-Nr.:

**Service • Assistenza • Dienstverlening • Serwis
Servis • Szerviz • Сервисная служба**

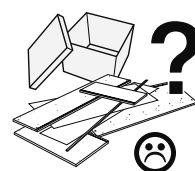
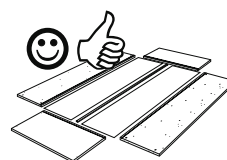
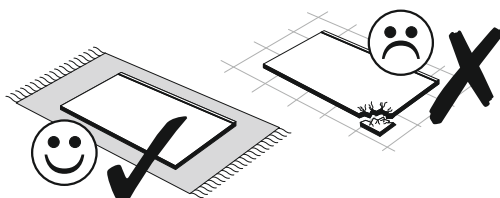
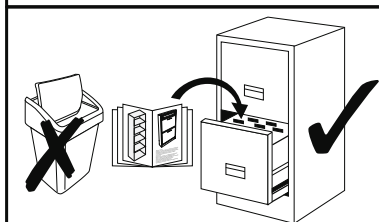
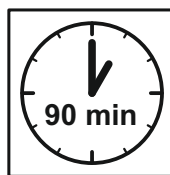
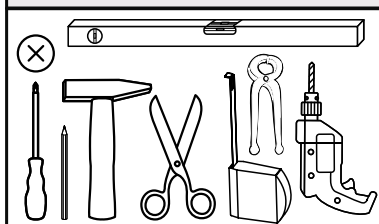

SCAN ME

Das Ersatzteil-Anforderungsformular finden Sie auf
The replacement parts requisition form you find on
<https://www.maeusbacher.de/ersatzteile/>

BT1-00230 Colli 2/3

B03-11		B03-43		B03-07	
4x		4x	15er	2x	

BT1-00246 Colli 2/3

B01-10		B01-30		B01-80		B01-90		B02-08	
4x	6,3x50	32x	3x16	8x	3,5x13	10x	3,5x20	8x	h=10mm
B01-150		B01-200		B01-206		B01-329		B02-10	
8x	4x35	8x	6,3x13	16x	6,3x22	4x	M4x22	24x	h=12mm
B02-20		B02-27		B02-103		B02-160		B01-70	
24x		4x		4x	8x30	8x		4x	3x30

BT1-00247 Colli 2/3

B05-130		B05-185		B05-190		B08-80		B06-396	
1x		4x		6x		1x		4x	

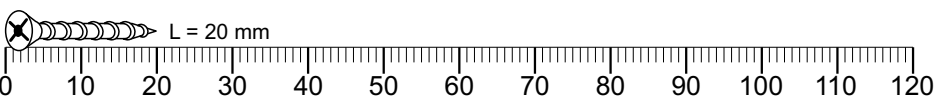

SCAN ME

Colli 1/3

FTx-000465	Z01-221-350	Z01-96-278	Z01-222-350	HTS-00070	Z99-00591
2x	2x	2x	2x	2x	2x
346 x 231	350 x 120	278 x 106	350 x 120	290 x 358	466 x 614





Colli 2/3

FTx-000457	FTx-000458	FTx-000462	FTx-000463	FTx-000460	HTR-00444	HTR-00445
1x	1x	1x	1x	2x	2x	1x
607 x 416	607 x 416	530 x 377	530 x 377	618 x 377	550 x 630	550 x 332
Z01-210L	Z01-210R	Z03-23	Z03-24			
2x	2x	2x	2x			

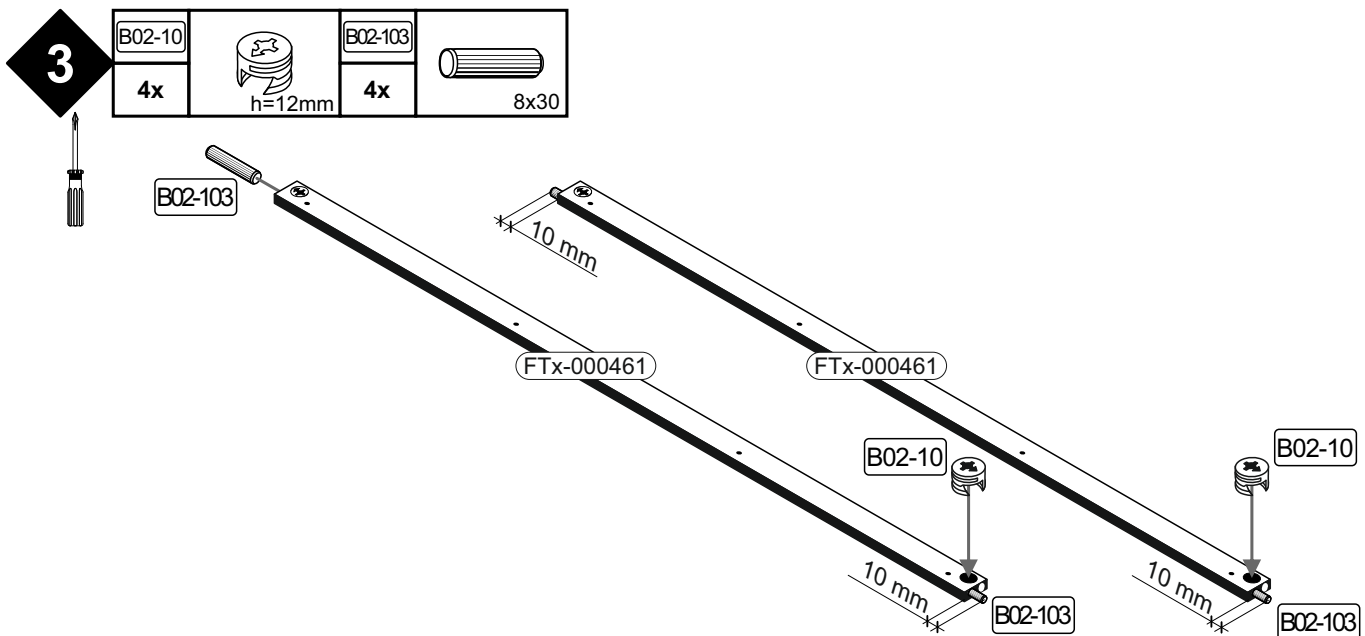
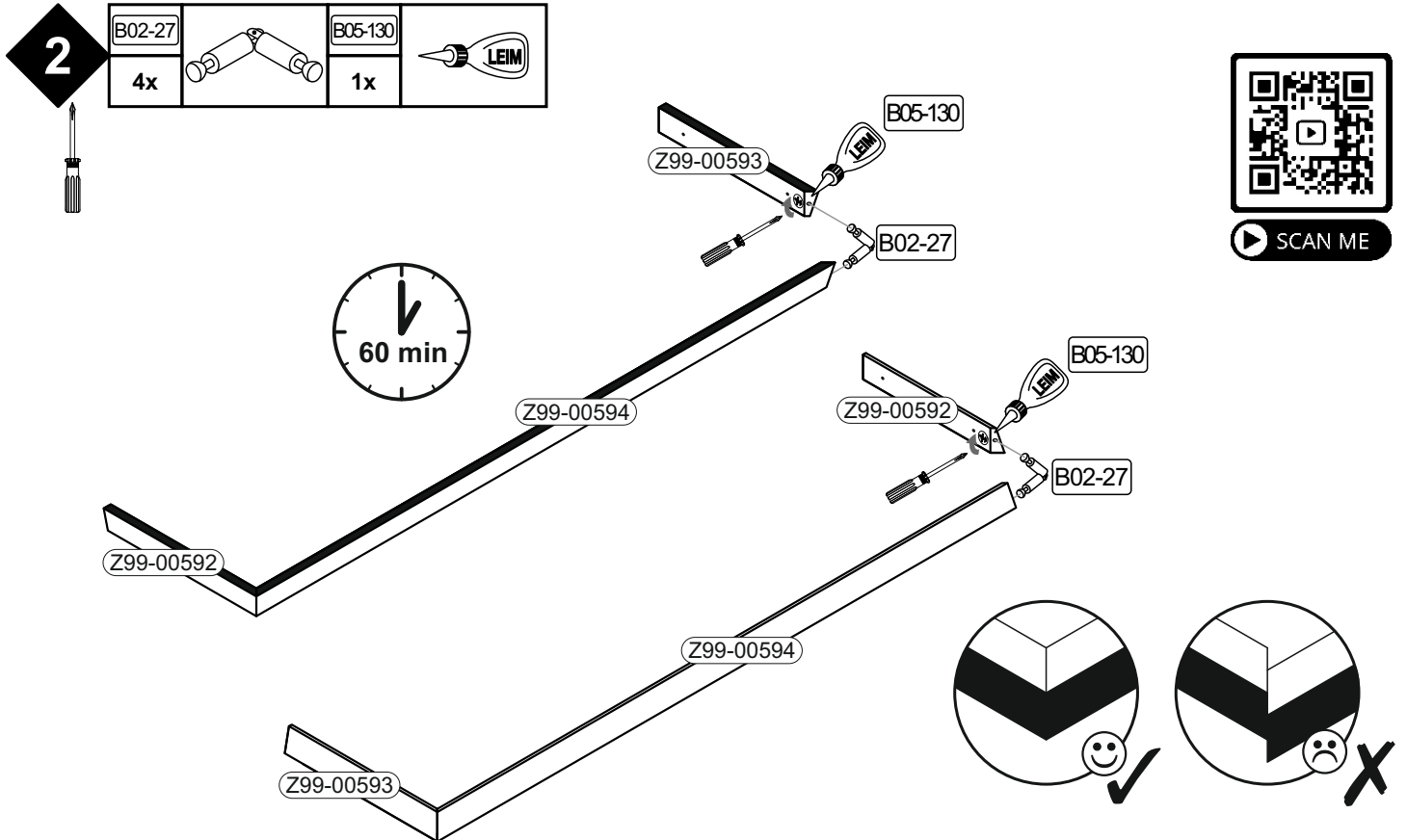
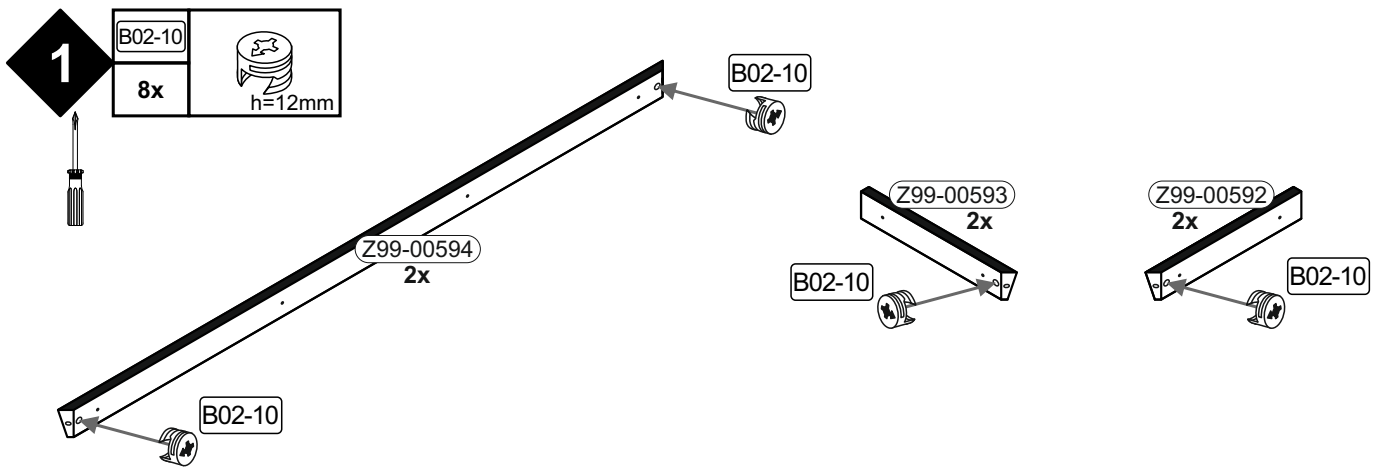

Colli 3/3

FTx-000464	FTx-000461	Z99-00592	Z99-00593	Z99-00594
1x	2x	2x	2x	2x
1614 x 416	1584 x 60	441 x 75	441 x 75	1663 x 75



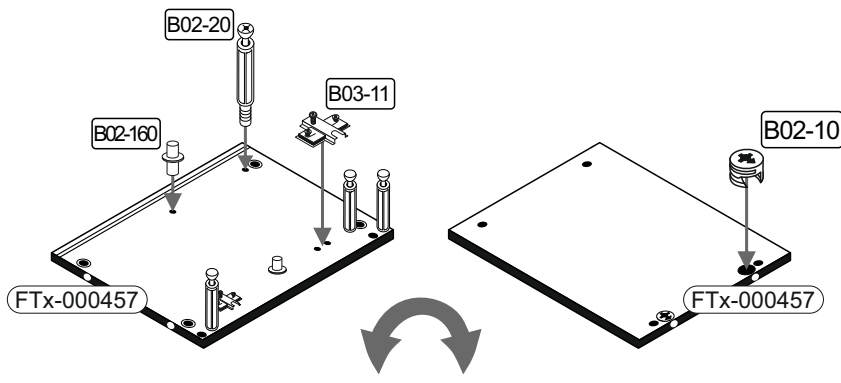

4	B02-10	 h=12mm	B03-11		B02-160		B02-20	
	2x		2x		2x		4x	

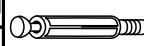

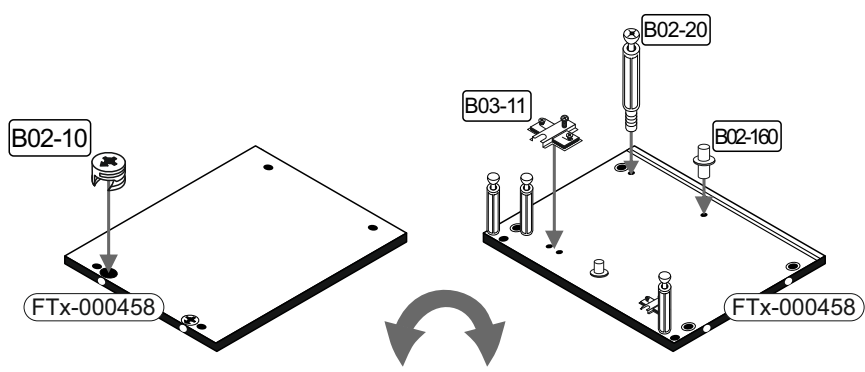
5	B02-10	 h=12mm	B03-11		B02-160		B02-20	
	2x		2x		2x		4x	



6	B02-10	 h=12mm	B05-190	
	4x		3x	

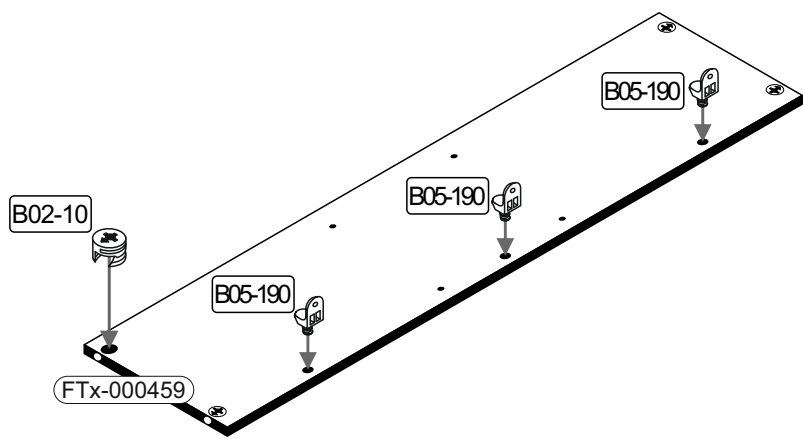
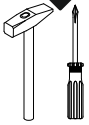

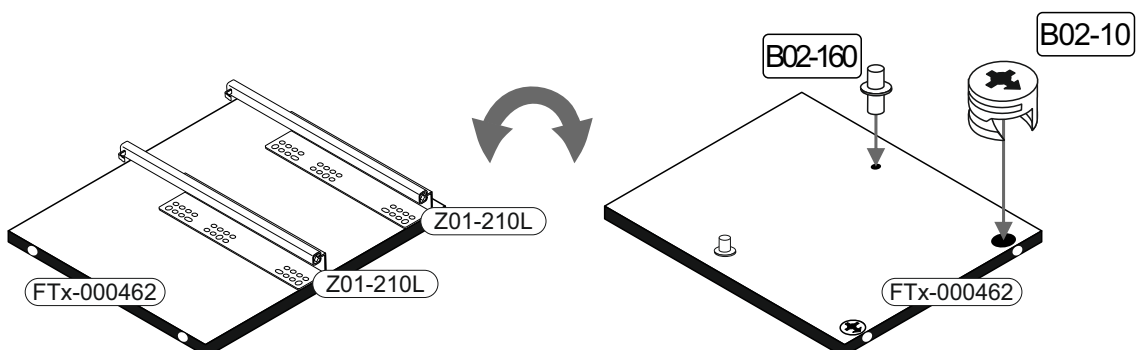
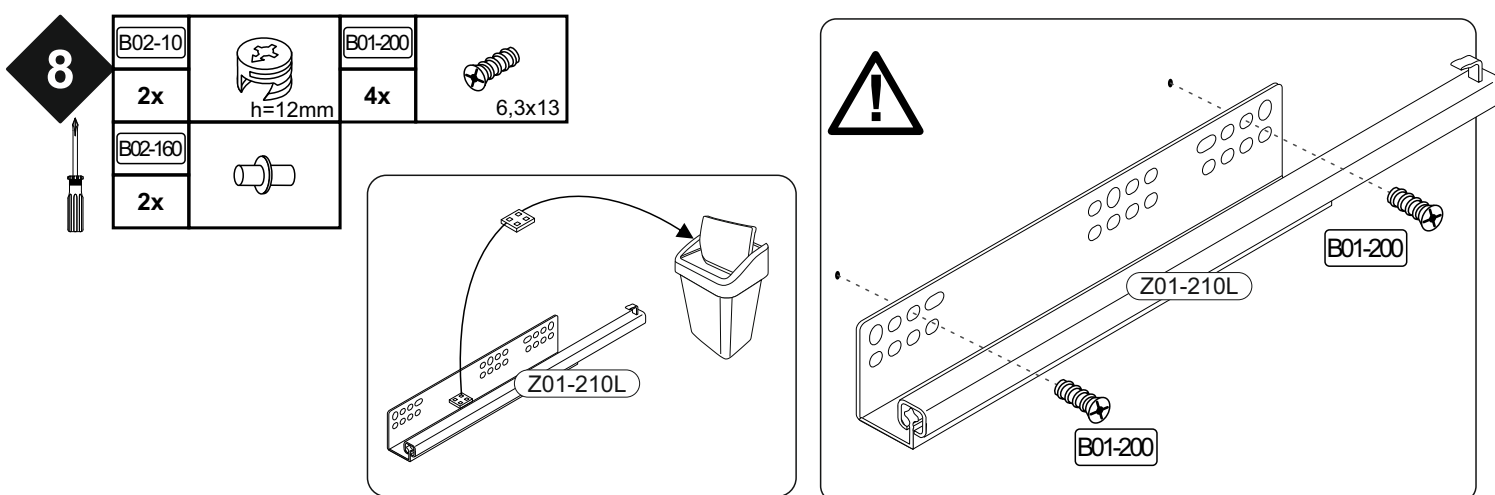
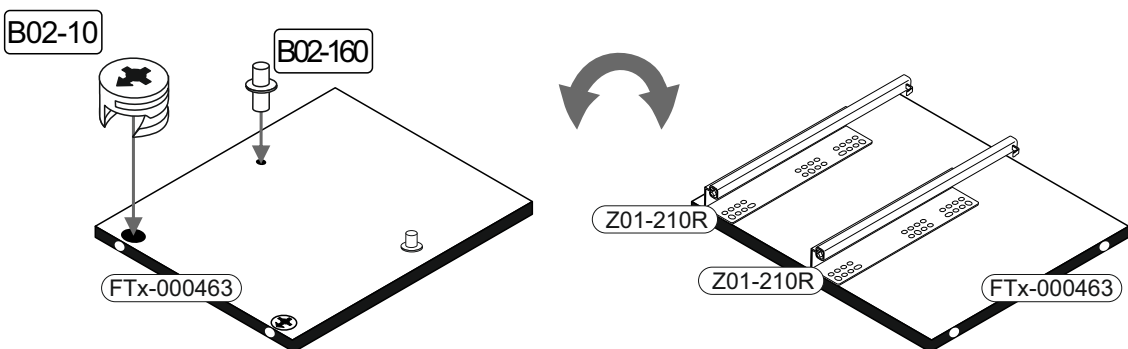
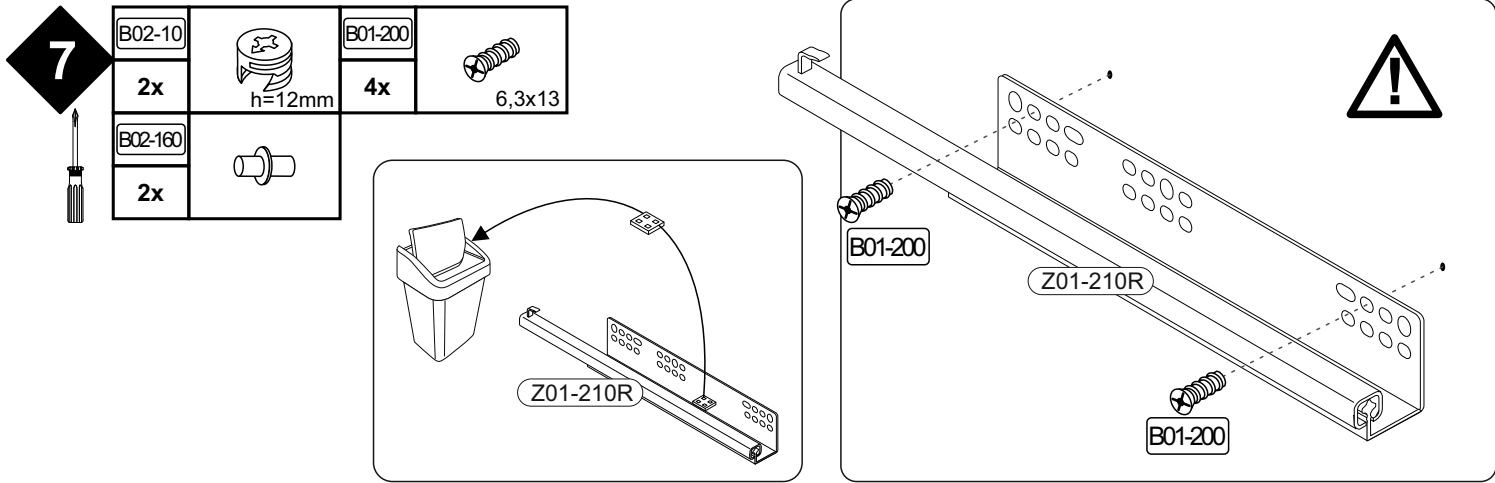

9

B05-190		B02-20	
3x		8x	

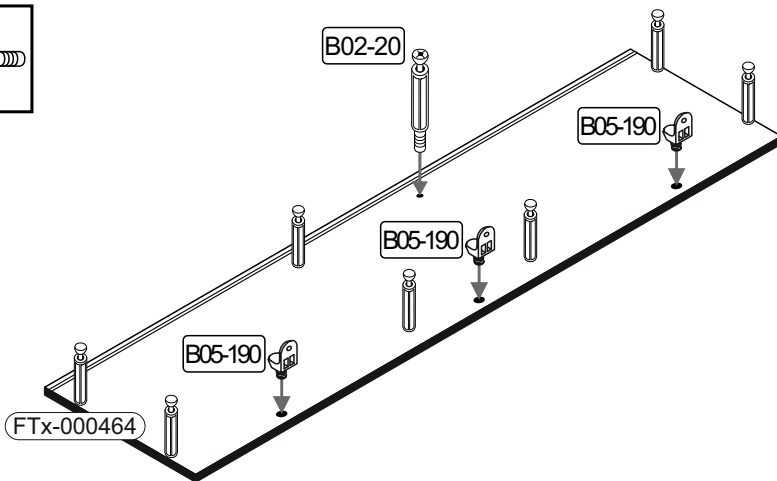

10

B02-08		B02-20		B01-329		B06-396	
8x	h=10mm	8x		2x	M4x22	2x	

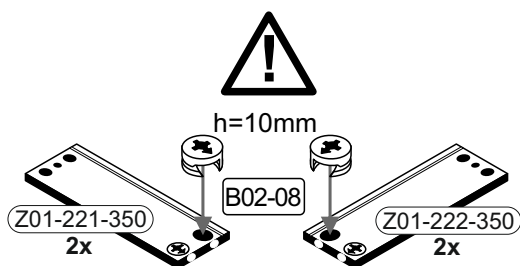
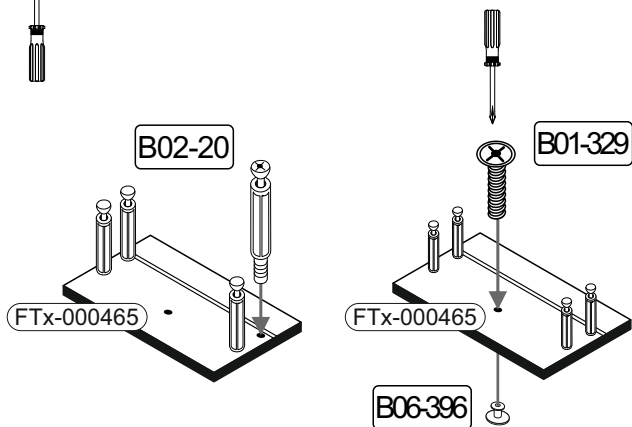

11

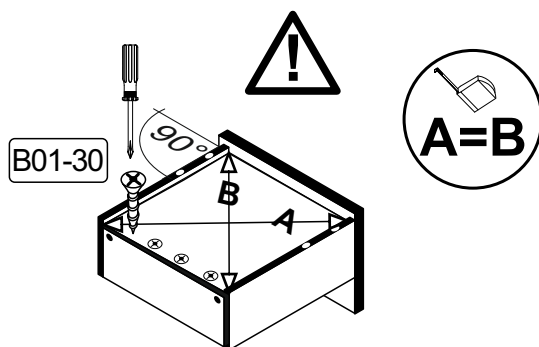
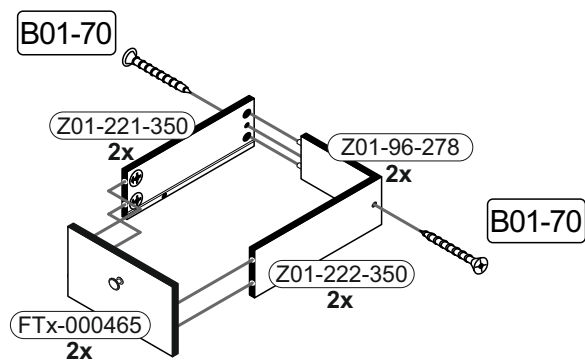
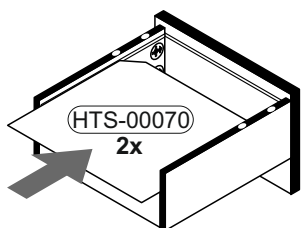
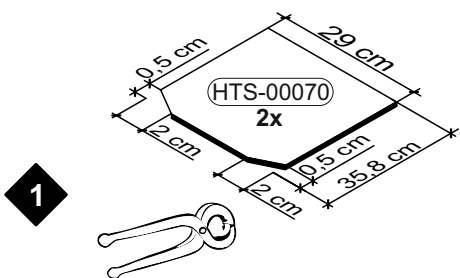

B01-30		B01-70	
8x	3x16	4x	3x30

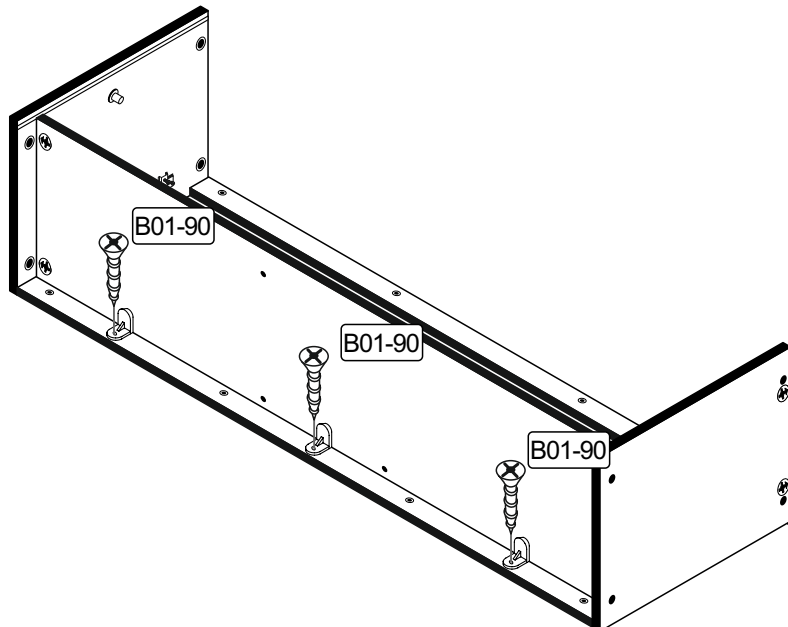
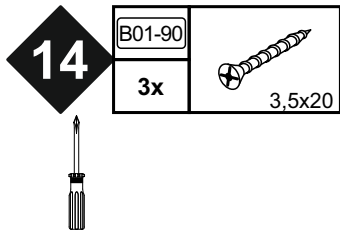
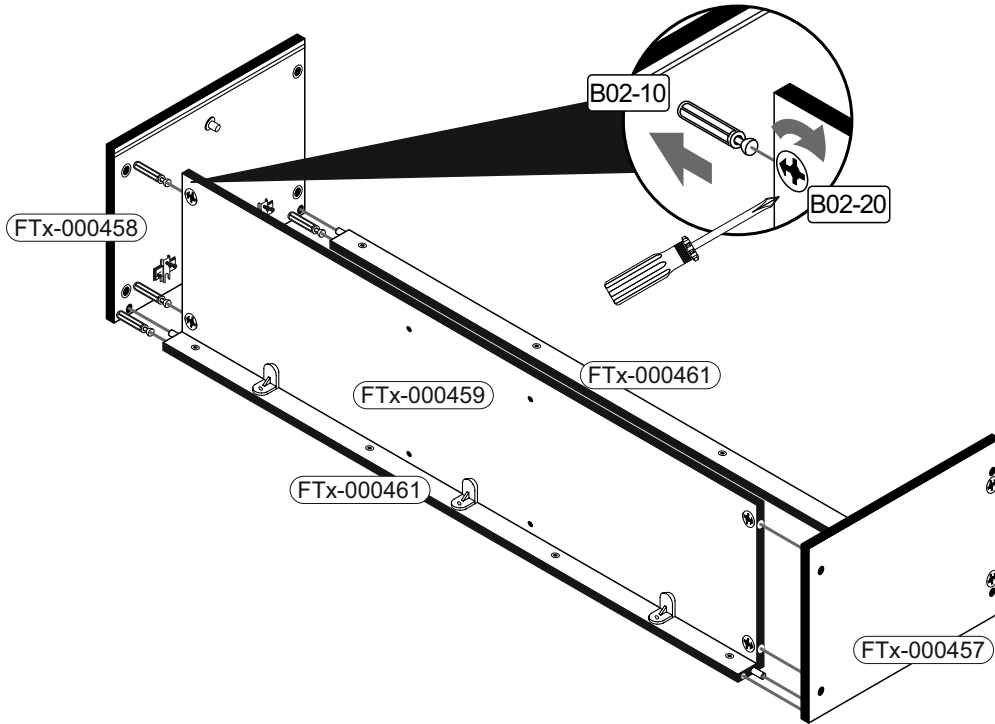
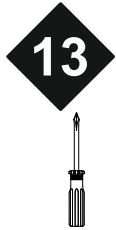
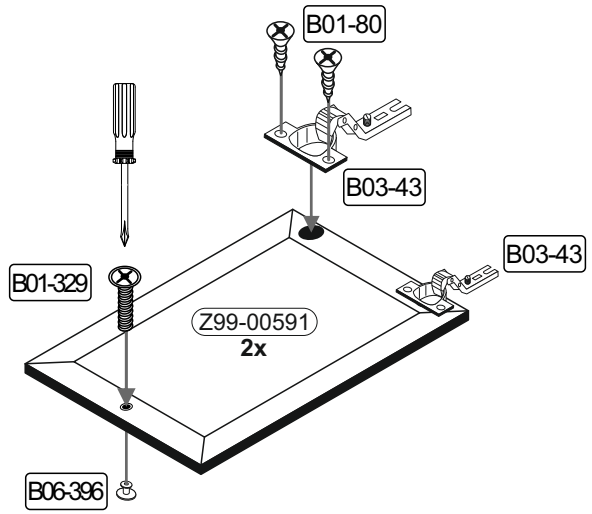
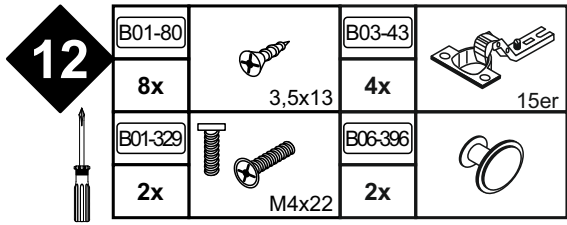

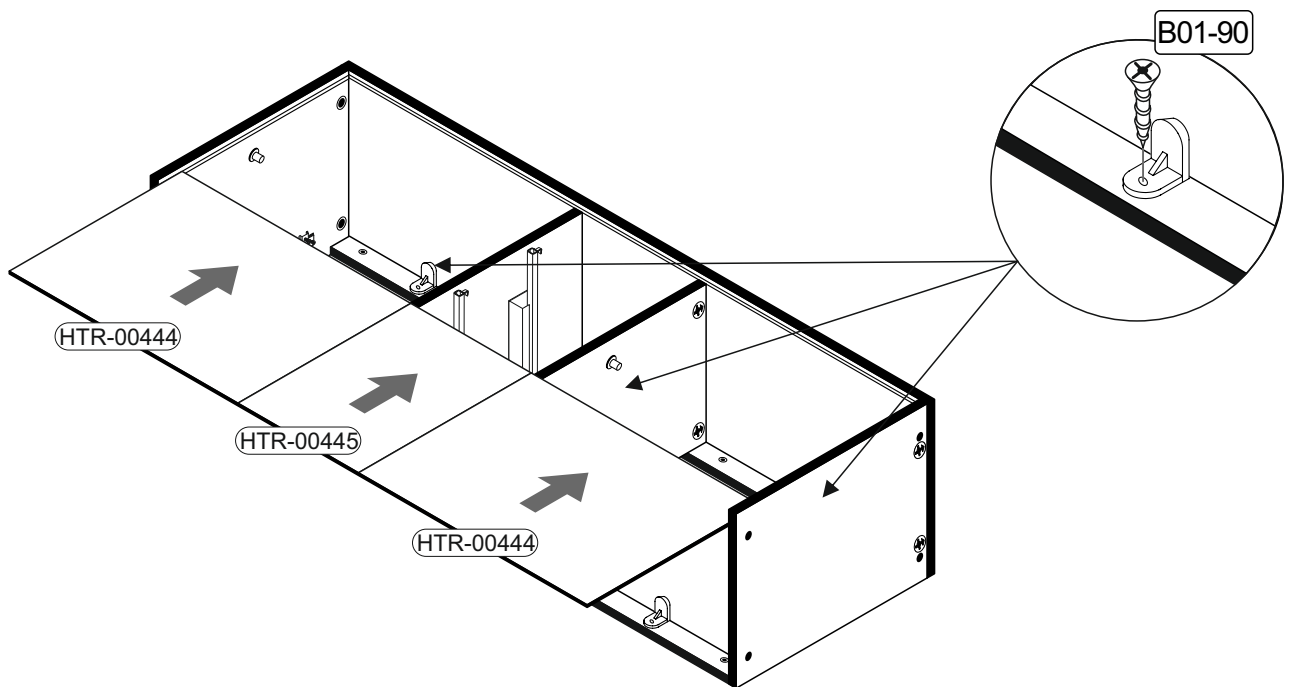
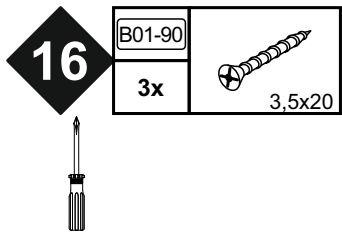
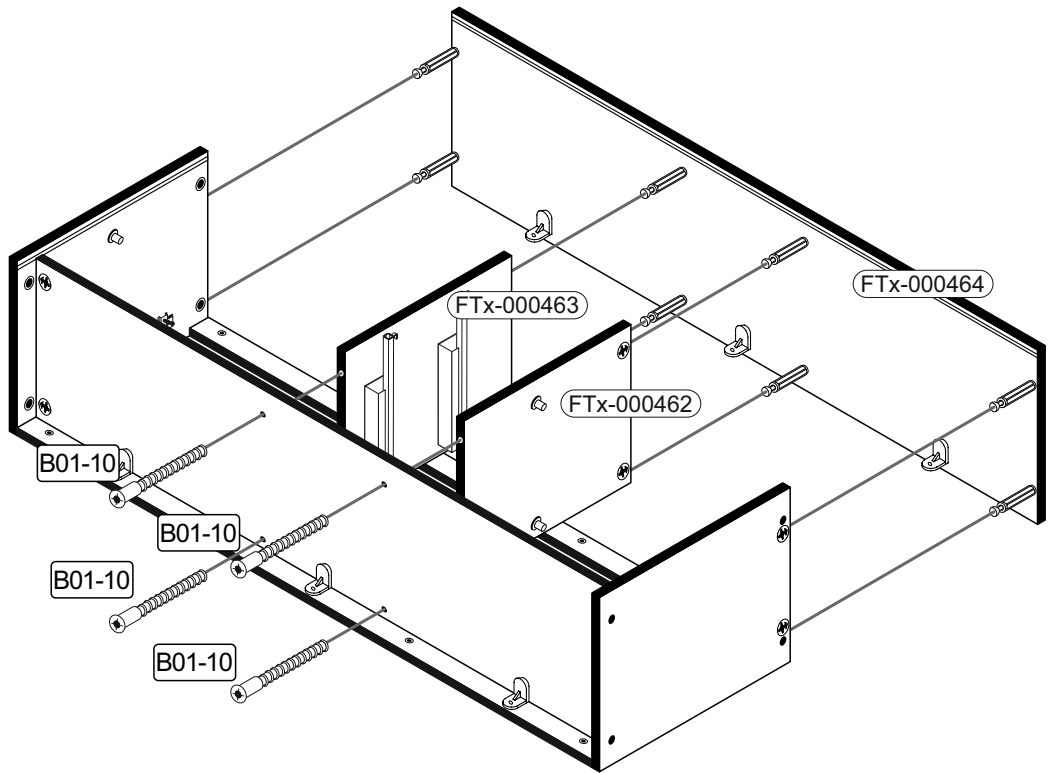
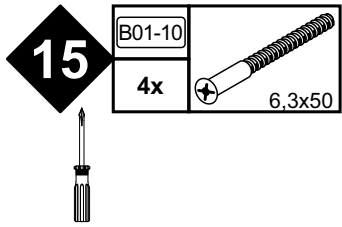

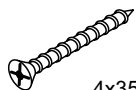

17

B01-30		B05-185		B01-90		B01-150	
24x	3x16	4x	4x	4x	3,5x20	8x	4x35

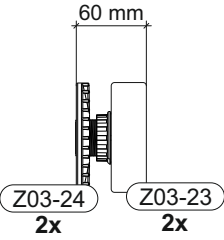
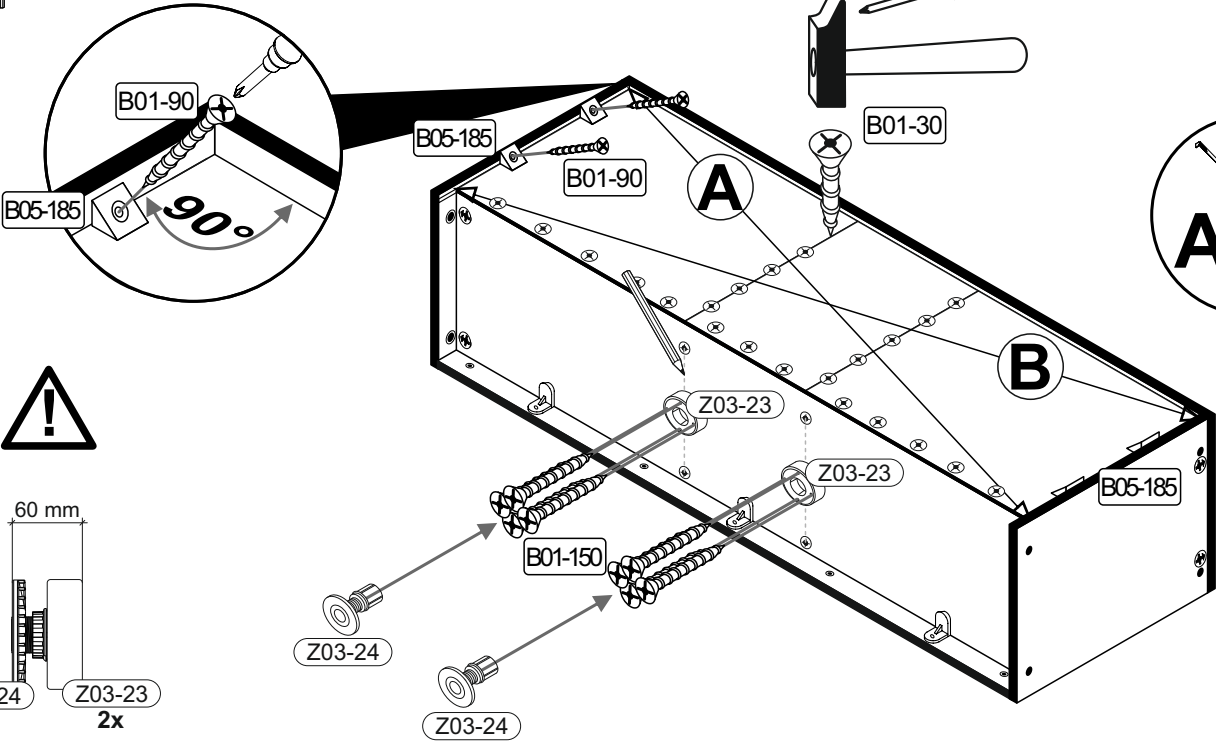
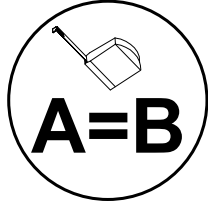
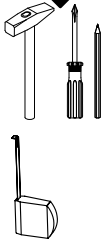

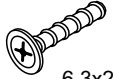

18

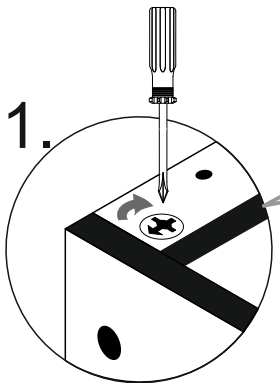
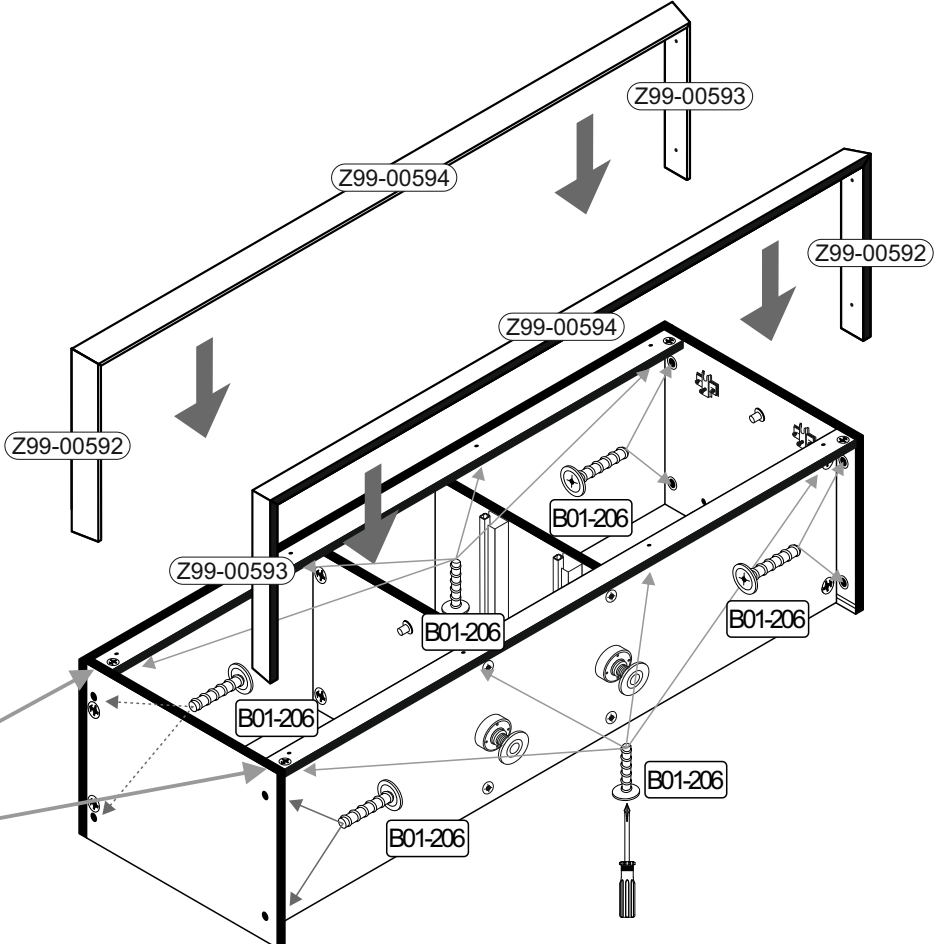
B01-206	
16x	6,3x22

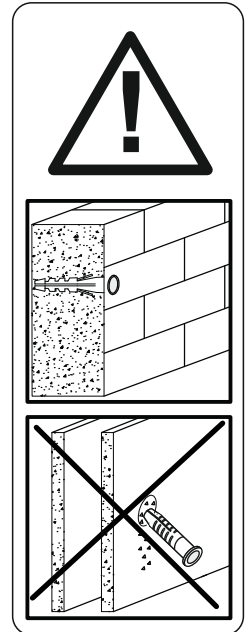
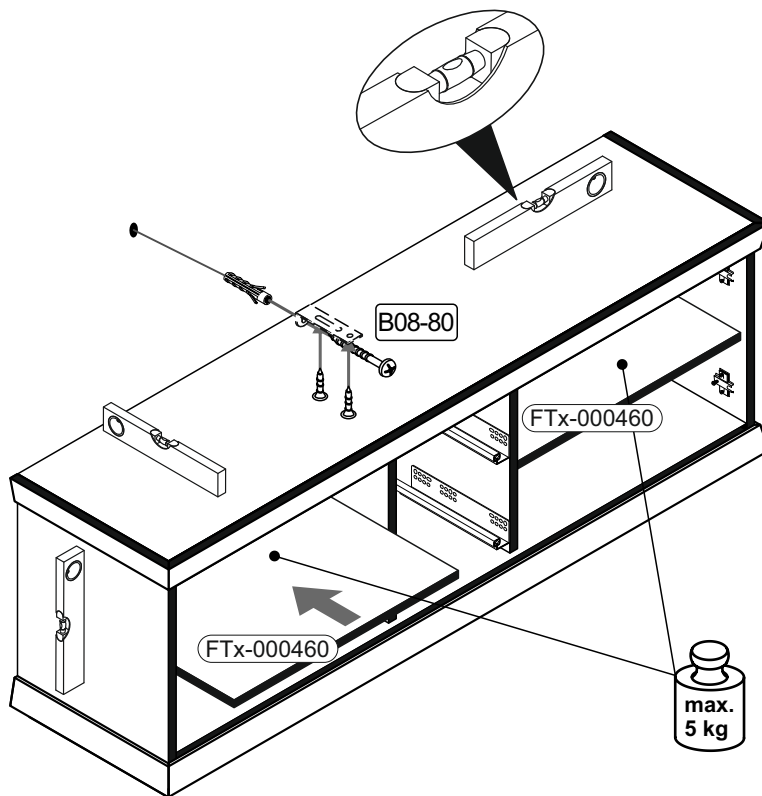
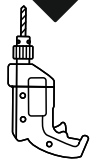
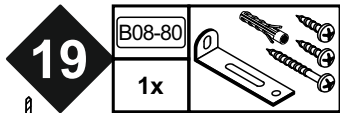



 Achtung • Attention • Attenzione • Opgelet • Uwaga • Pozor • Figyelem • Atenție • Dikkat • Внимание 	
(D)	Wandbefestigung dient als Kippschutz - unbedingt anbringen! Bei einigen Wandtypen kann ein Spezialdübel erforderlich sein!
(GB)	The wall fastening serves to prevent tipping - be absolutely sure to mount it! For certain wall types, a special wall plug may be necessary!
(FR)	La fixation murale sert de protection contre le basculement – à installer impérativement ! Pour certains types de murs il faut des chevilles spéciales !
(TR)	Duvardaki sabitleme, devrilmeye karşı bir emniyet tedbiridir ve mutlaka monte edilmelidir! Bazı duvar tiplerinde bunun için özel bir dübel gerekli olabilir!
(IT)	Il fissaggio alla parete serve da protezione anti-ribaltamento – attaccarla assolutamente! Per alcune strutture di parete può essere necessario un tassello speciale!
(NL)	Bevestiging aan de muur dient als kantelbescherming – zeker en vast bevestigen! Bij enkele muurtypes is een speciale plug misschien vereist!
(RU)	Обязательно установите крепление на стене во избежание опрокидывания! Для некоторых типов стен может потребоваться специальный дюбель!
(CZ)	Montáž na stěnu slouží jako ochrana proti převrnutí – bezpodmínečně umístěte! U některých typů stěn může být zapotřebí speciální hmoždinka!
(HU)	A terméket a falhoz kel rögzíteni, különben az felborulhat! Egyes faltípusoknál speciális tiplít kell használni!
(RO)	Sistemul de fixare la perete servește ca protecție la răsturnare - de montat obligatoriu! Pentru unele tipuri de pereți este posibil să fie necesar un diblu special!
(PL)	Mocowanie do ściany jest jednocześnie zabezpieczeniem przed przewróceniem – koniecznie zamontować! Do niektórych rodzajów ścian koniecznie zastosować specjalne kołki mocujące.
(SK)	Upevnenie na stenu slúži ako ochrana proti prevráteniu – bezpodmienečne použiť! Pre niektoré druhy stien môže byť potrebná špeciálna hmoždinka!



▶ SCAN ME

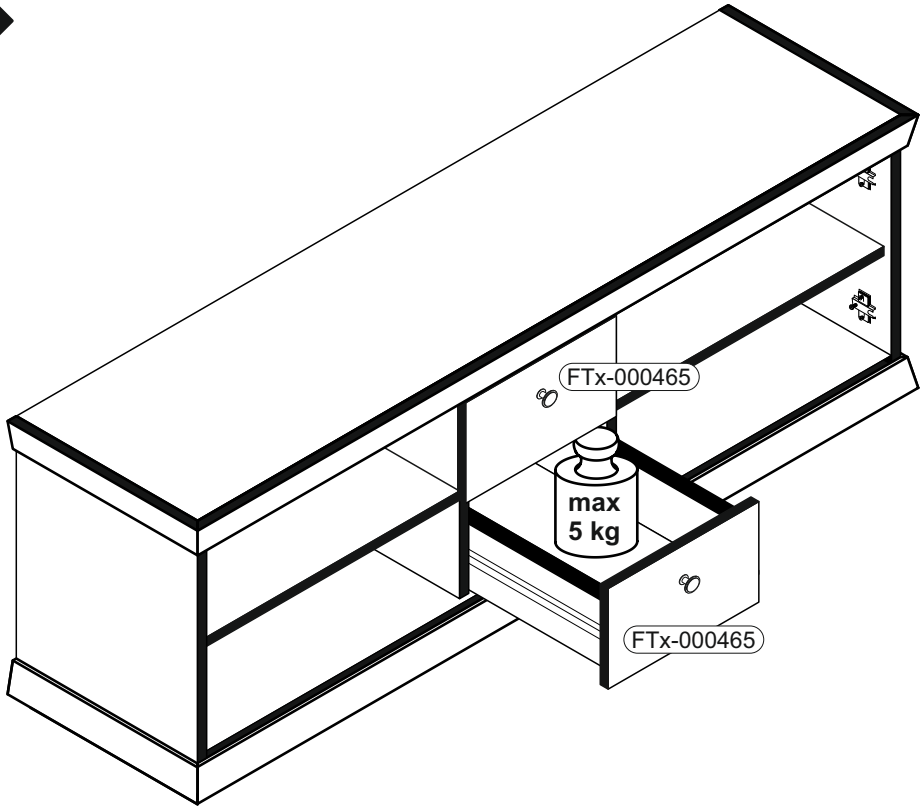

1.

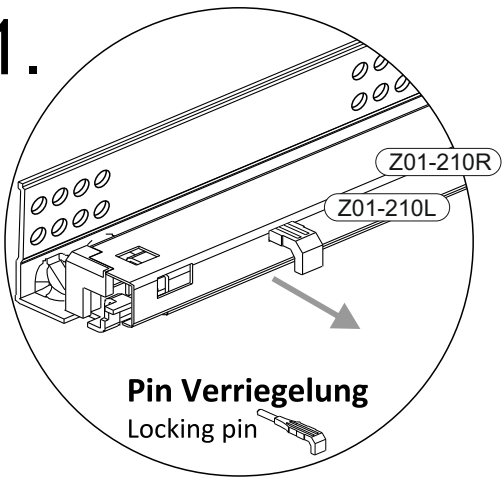

2.

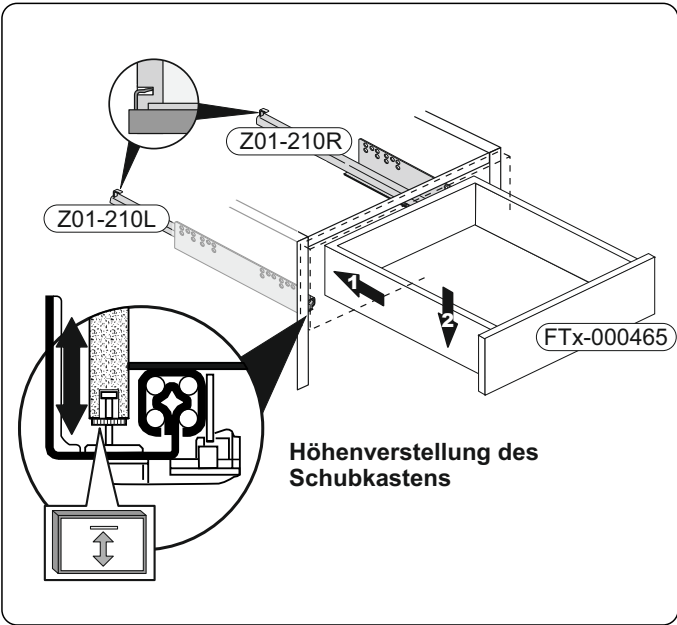

3.

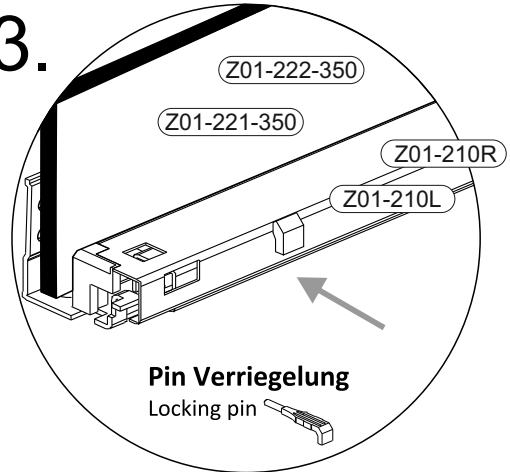

21

B03-07	
2x	



▶ SCAN ME

