

Babushka

komoda/ chest of drawers

wood luck

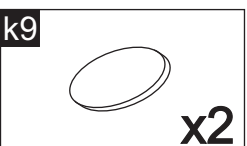
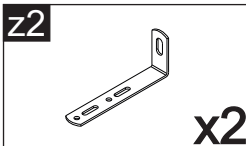
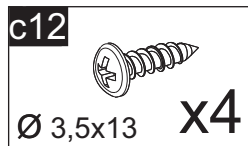
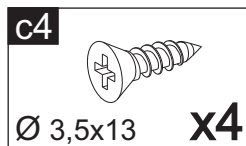
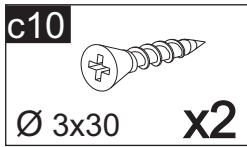
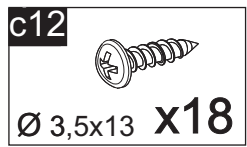
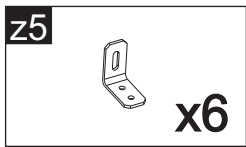
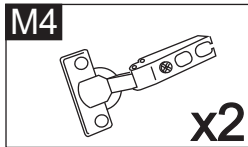
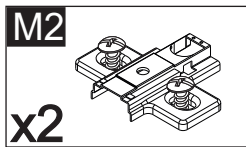
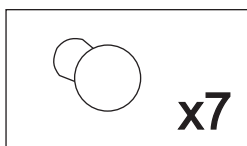
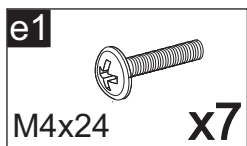
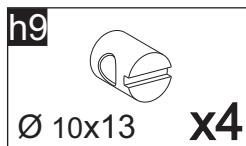
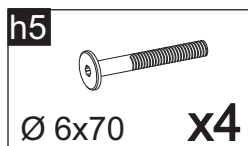
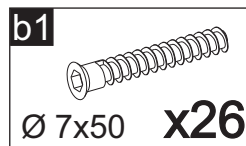
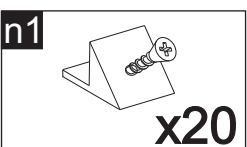
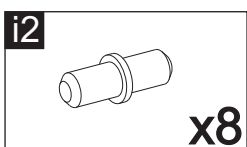
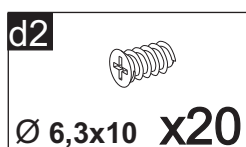
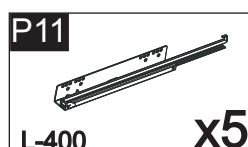
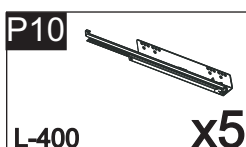
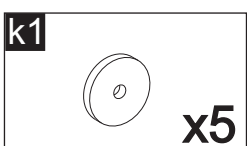
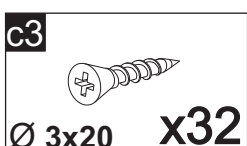
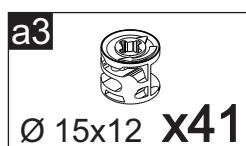
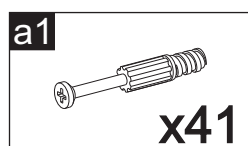
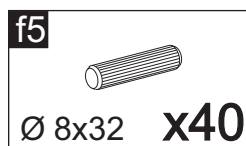
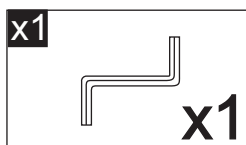
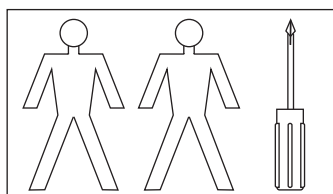
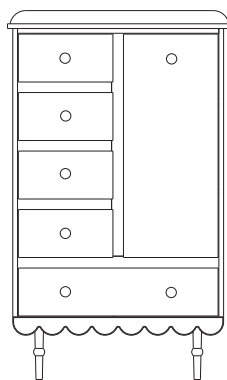

MONTOWAĆ NA MIĘKKIM PODŁOŻU, ABY NIE USZKODZIĆ ELEMENTÓW

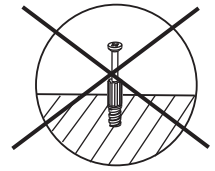
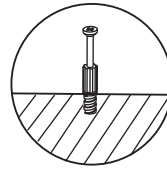
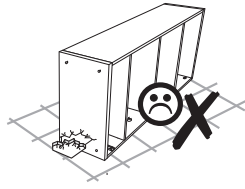
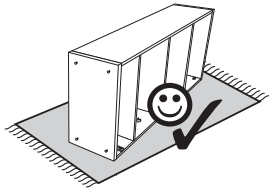

ASSEMBLE ON A SOFT SURFACE TO AVOID DAMAGING THE COMPONENTS

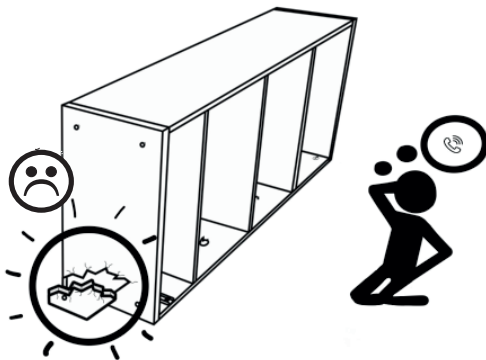
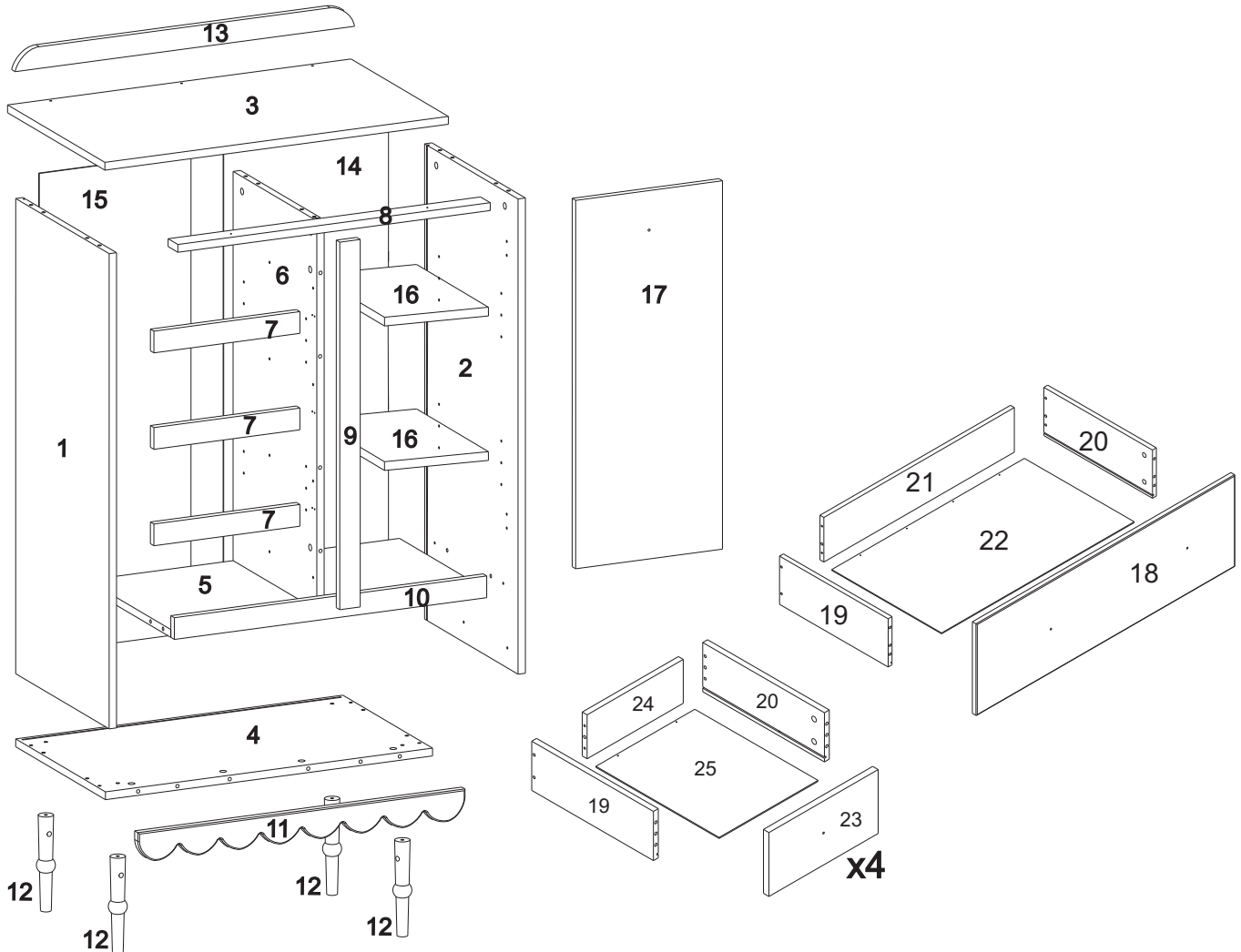

**przed montażem mebli,
sprawdzić elementy!
before assembling,
check the components!**

element no./ numer elementu	dł./l.	x	szer./w.	szt./qty.
1	1094	x	480	1.0
2	1094	x	480	1.0
3	844	x	504	1.0
4	806	x	468	1.0
5	764	x	430	1.0
6	896	x	430	1.0
7	357	x	51	3.0
8	764	x	51	1.0
9	846	x	51	1.0
10	764	x	51	1.0
11	804	x	74	1.0
12	46	x	224	4.0
13	830	x	50	1.0
14	1104	x	402	1.0
15	1104	x	370	1.0
16	428	x	389	2.0
17	852	x	363	1.0
18	762	x	186	1.0
19	400	x	140	5.0
20	400	x	140	5.0
21	723	x	125	1.0
22	405	x	732	1.0
23	363	x	186	4.0
24	316	x	125	4.0
25	405	x	326	4.0

1

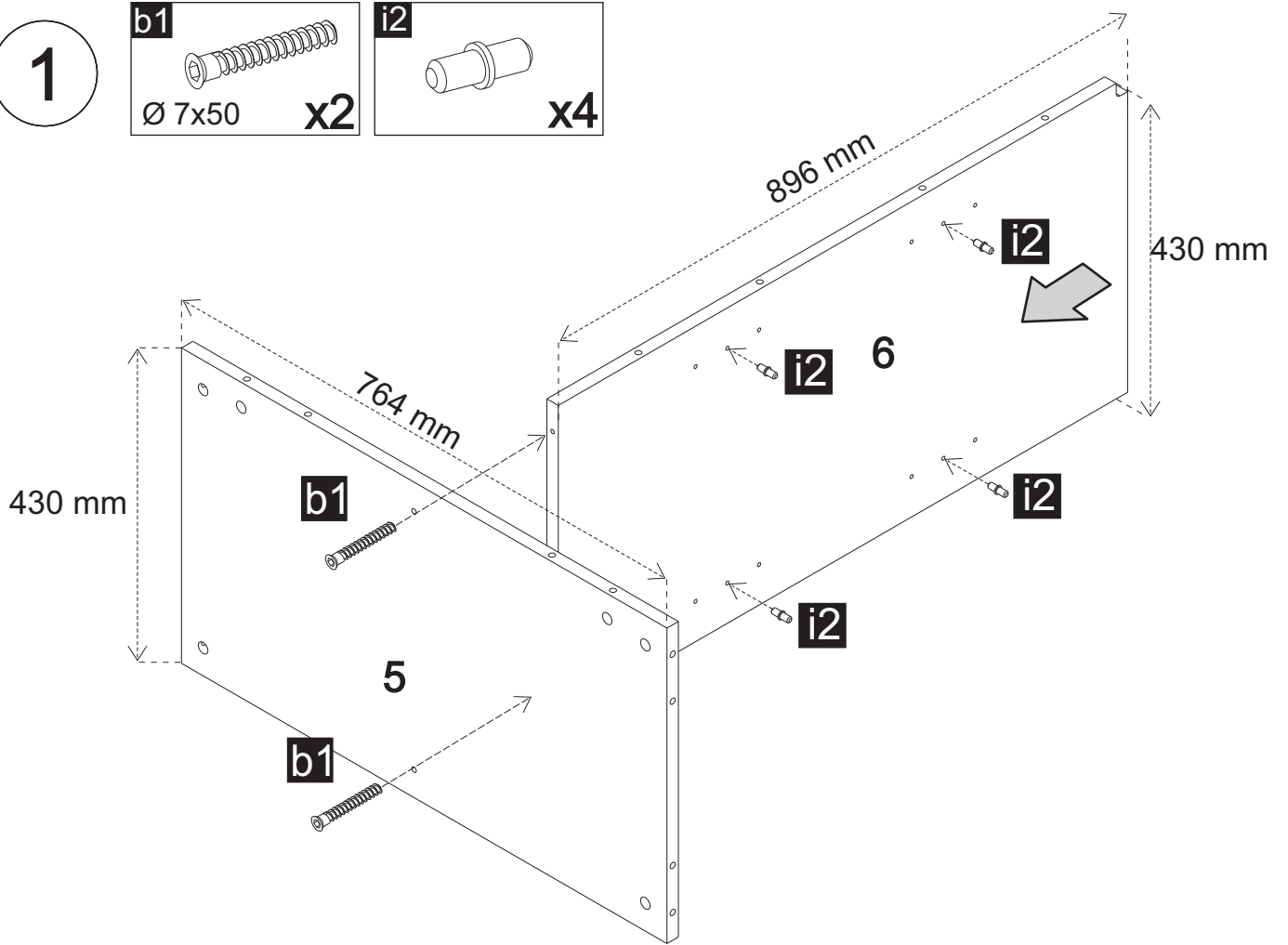
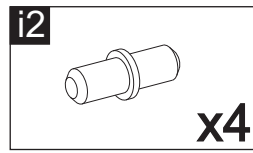
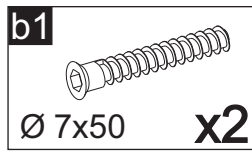

2

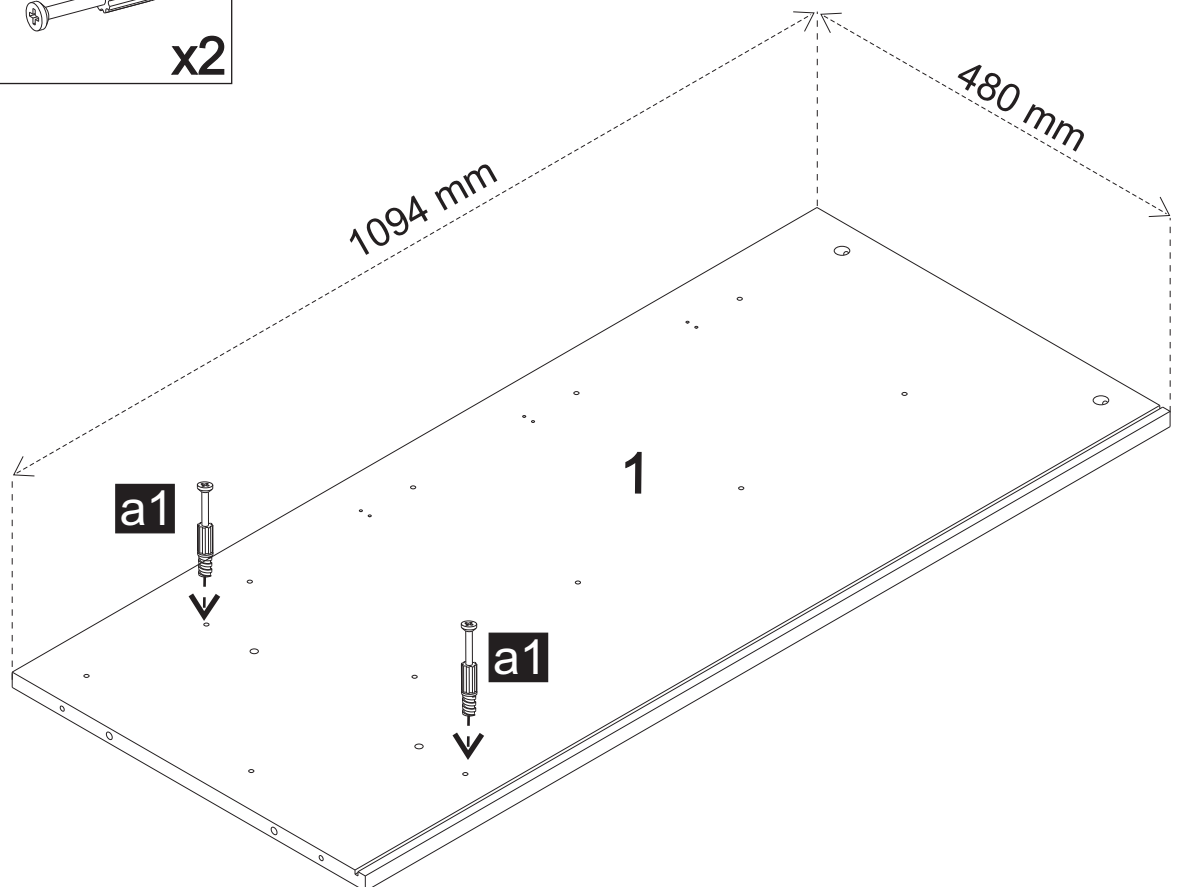
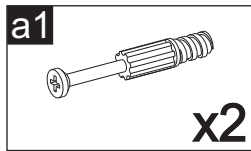

3

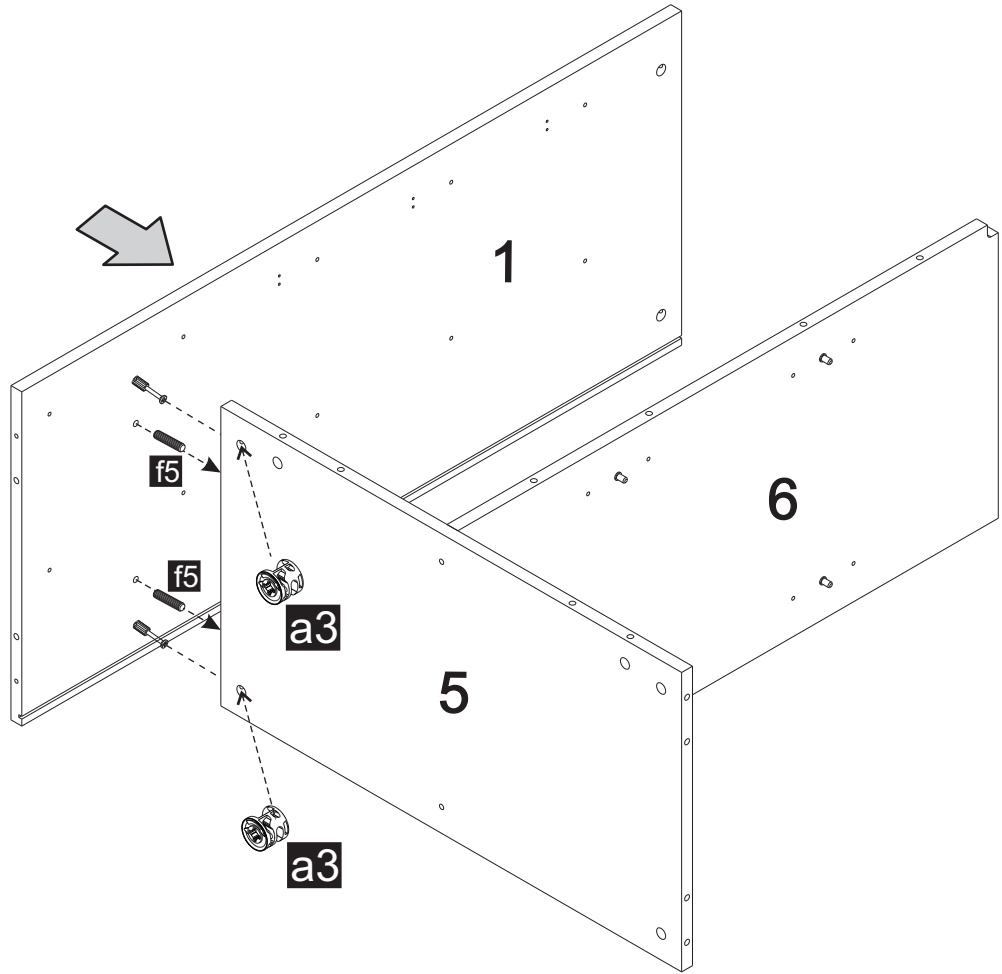
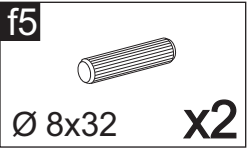

4

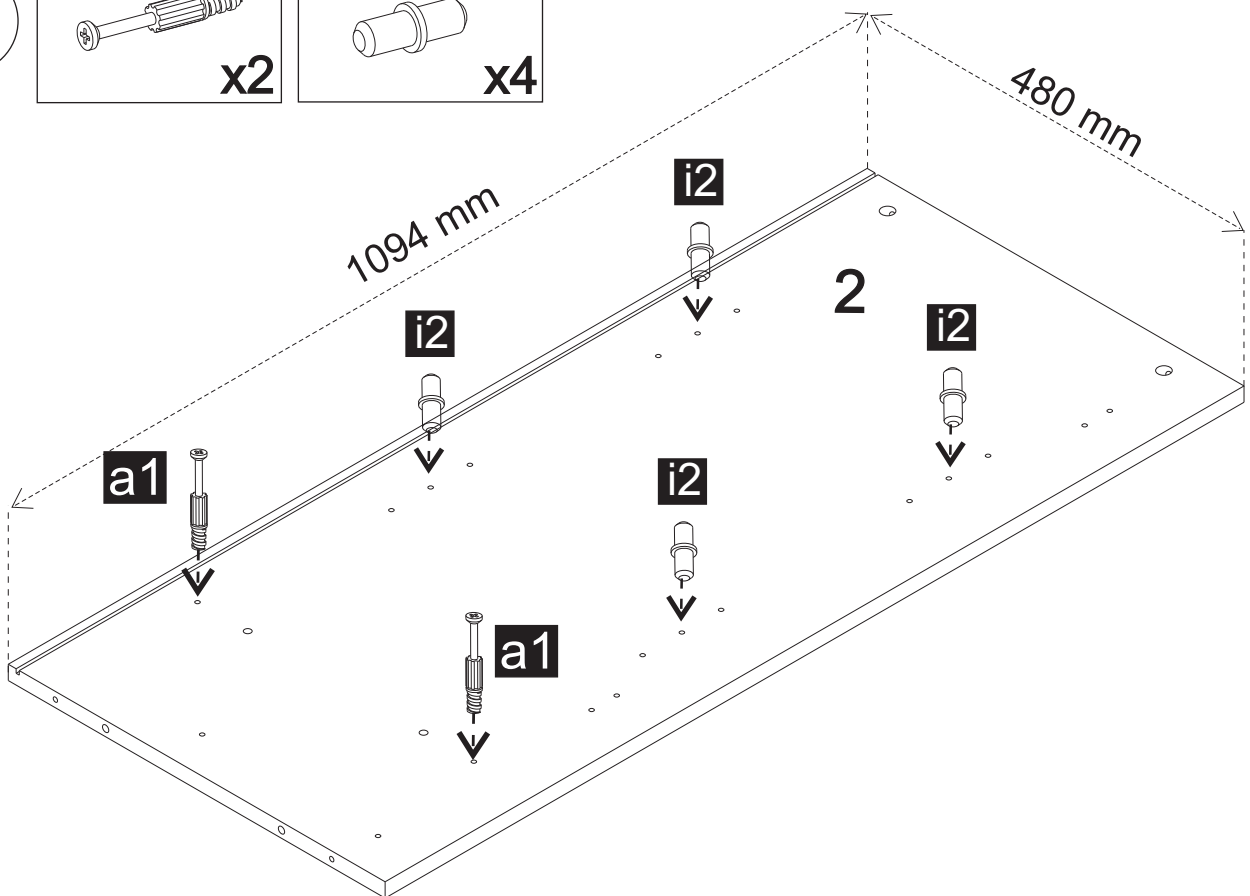
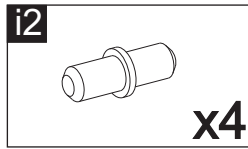
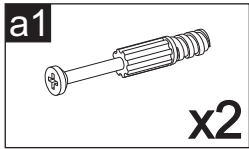

5

a3



Ø 15x12

x2

f5

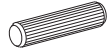

Ø 8x32

x2

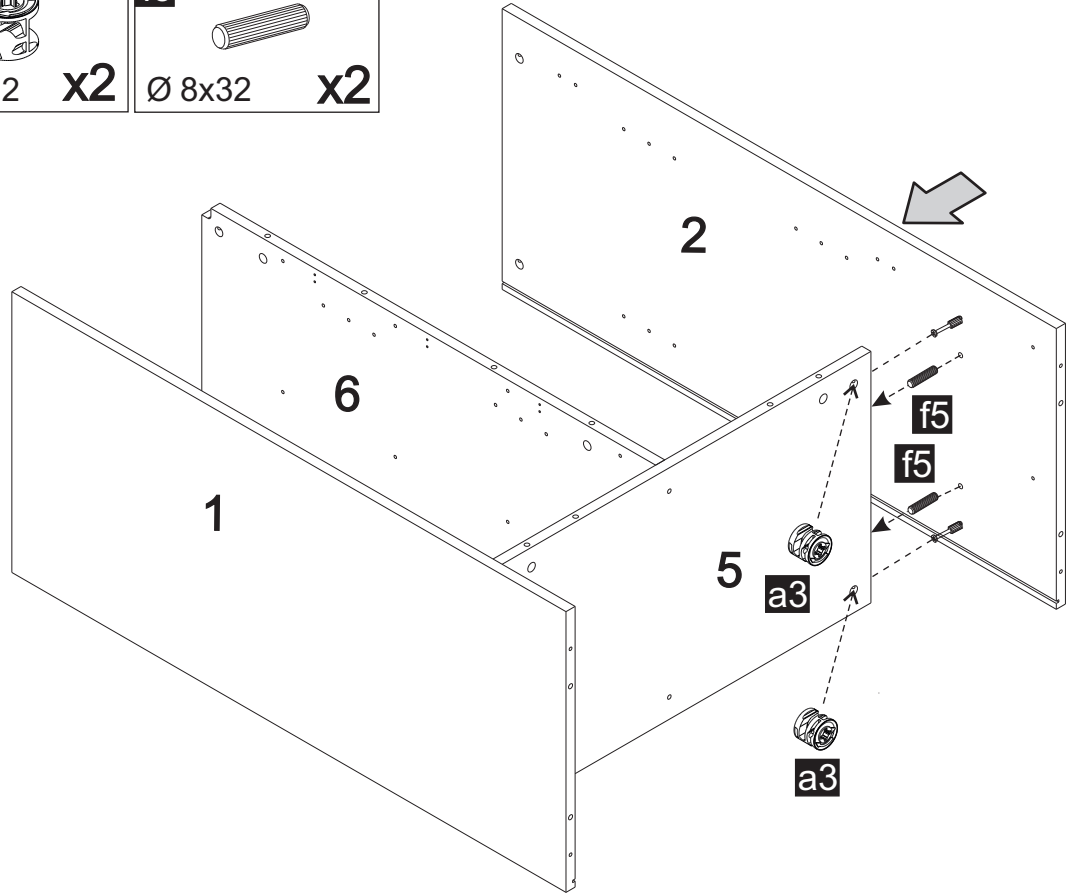

6

a1

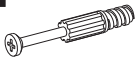

x4

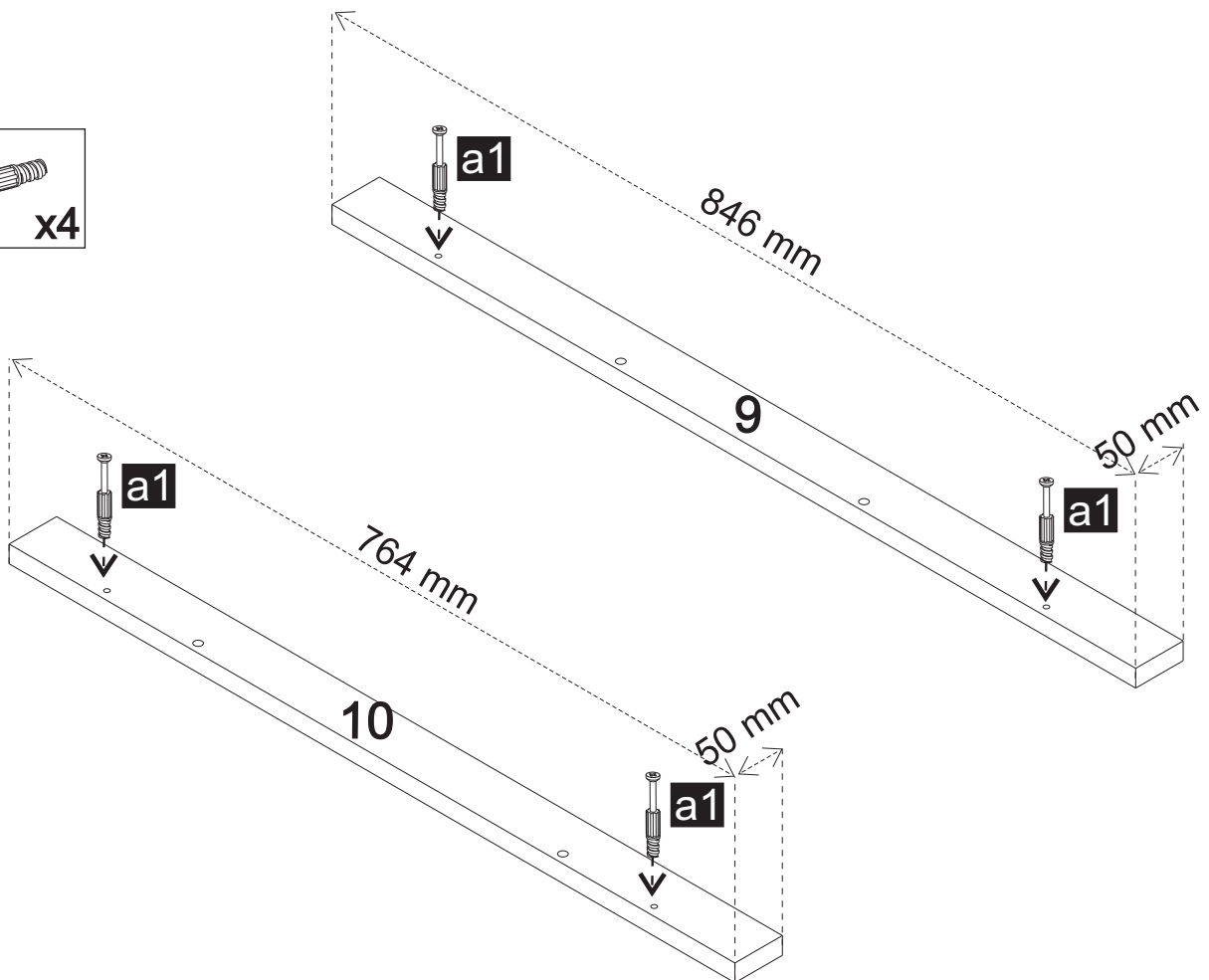

7

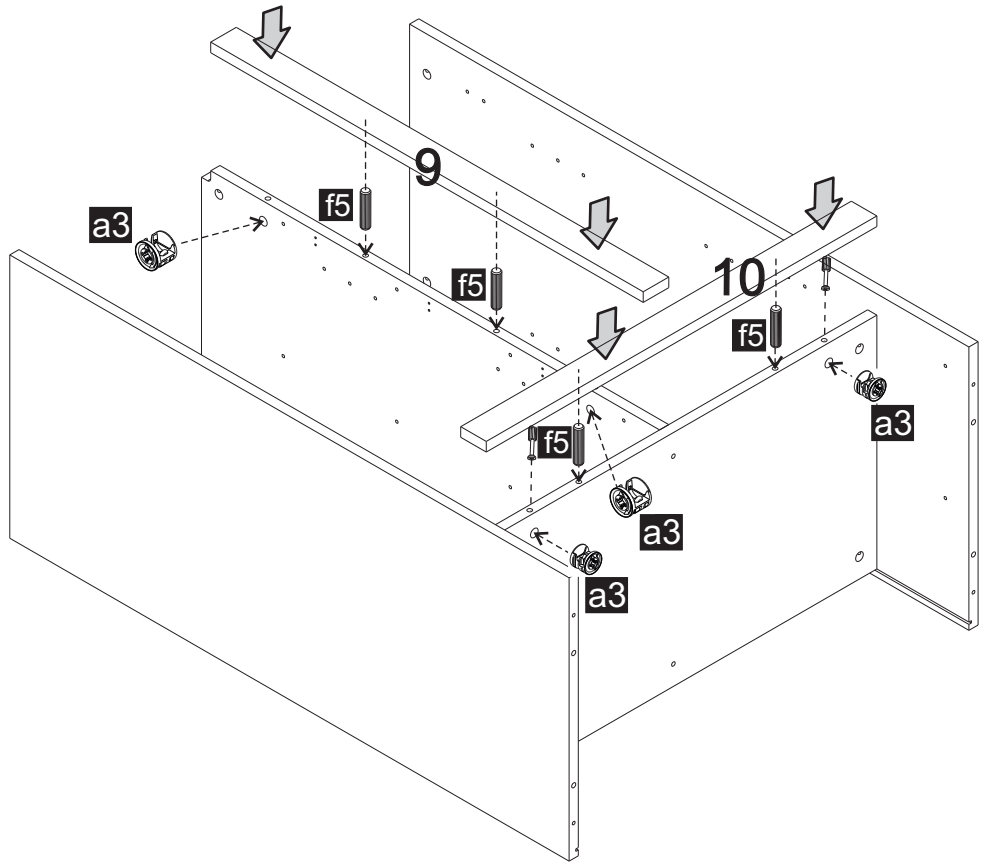
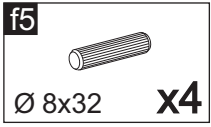
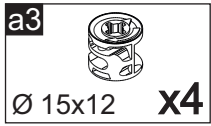

8

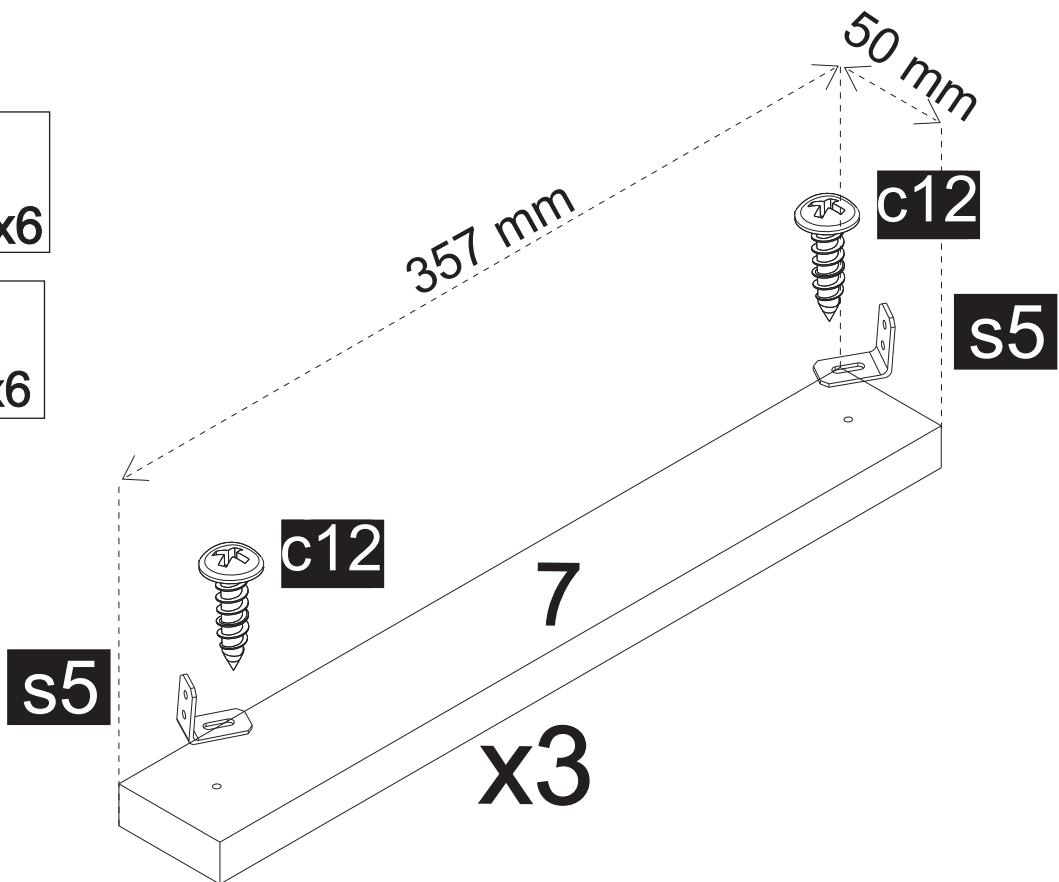
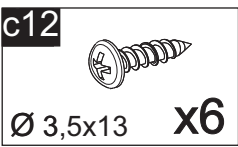
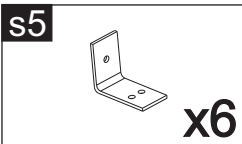

9

c12



Ø 3,5x13 x12

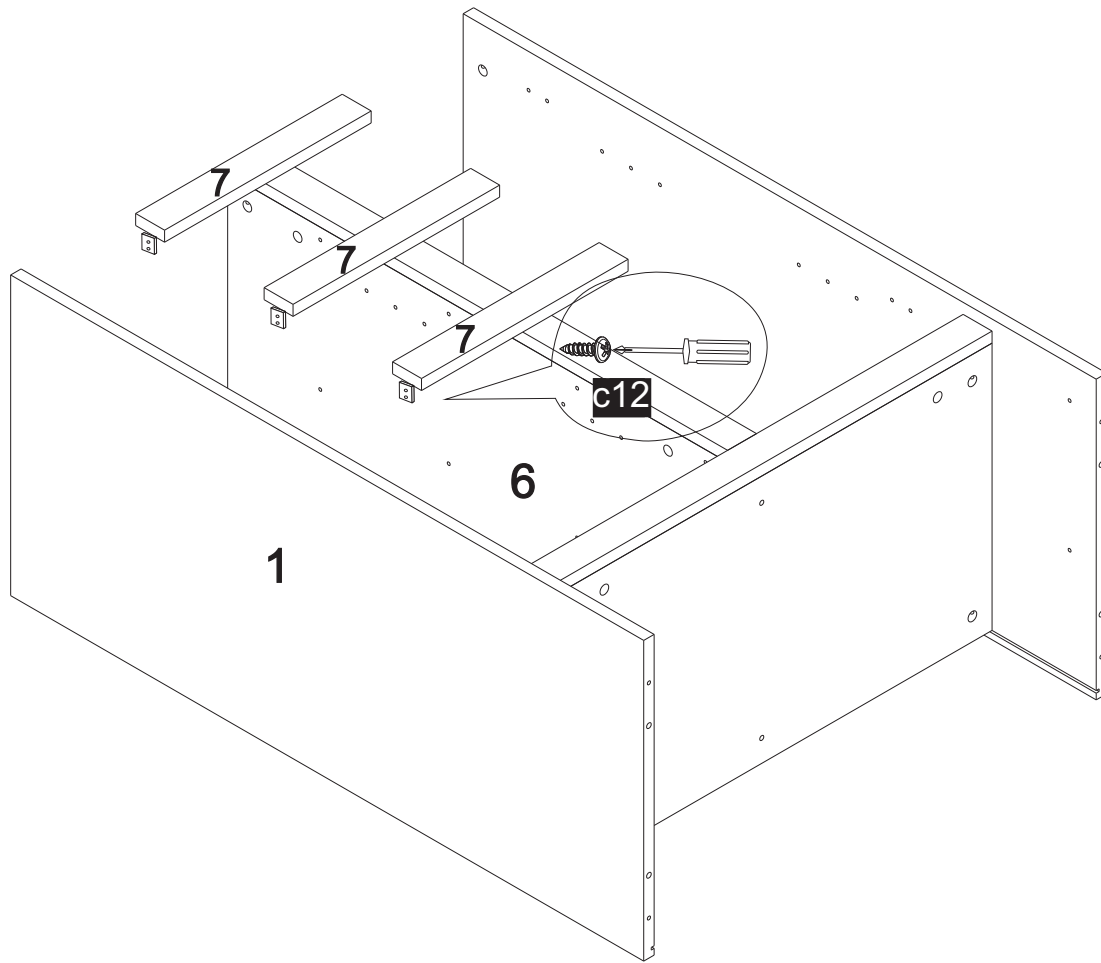

10

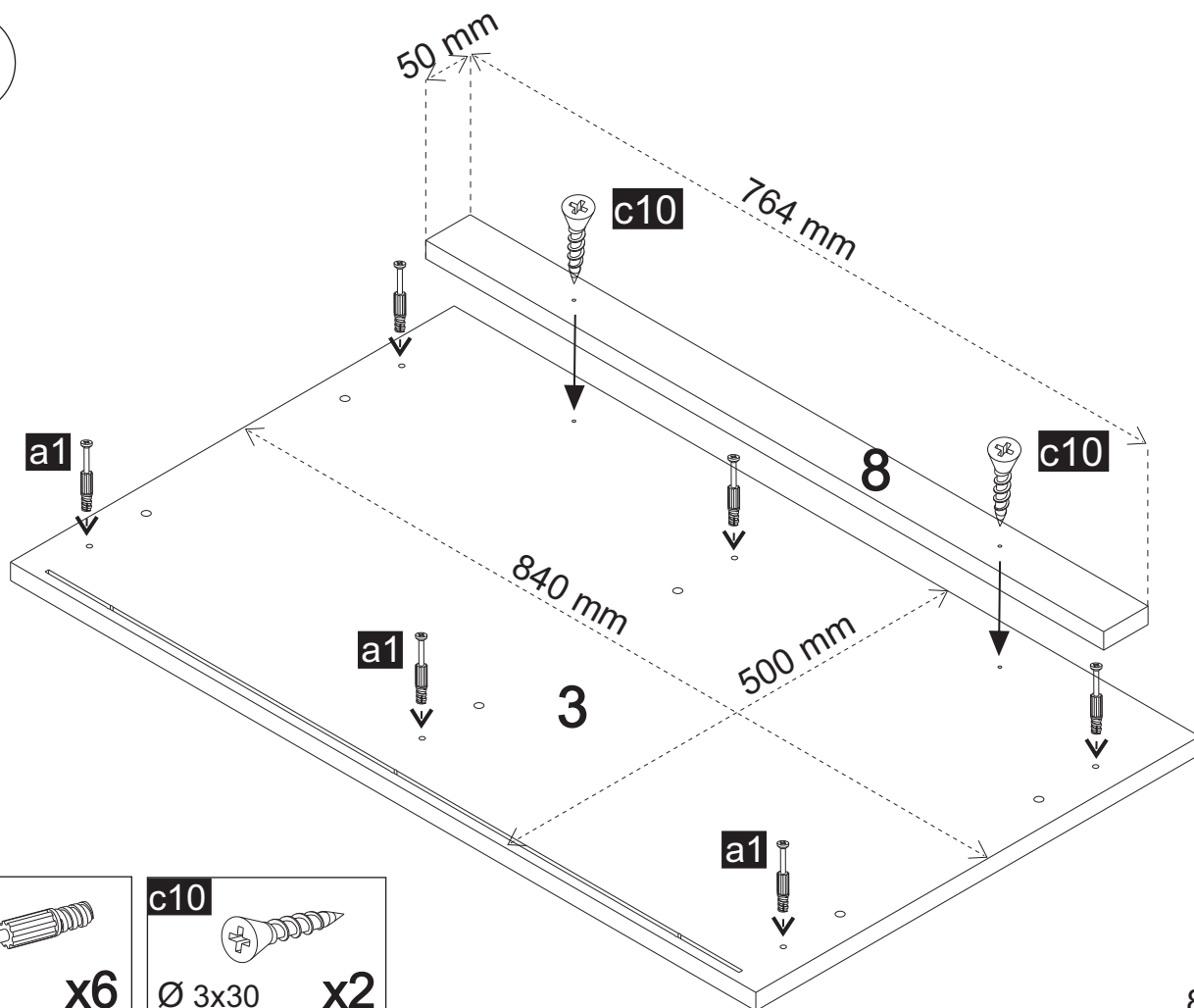

a1

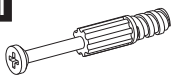

x6

c10

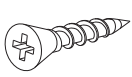

Ø 3x30 x2

11

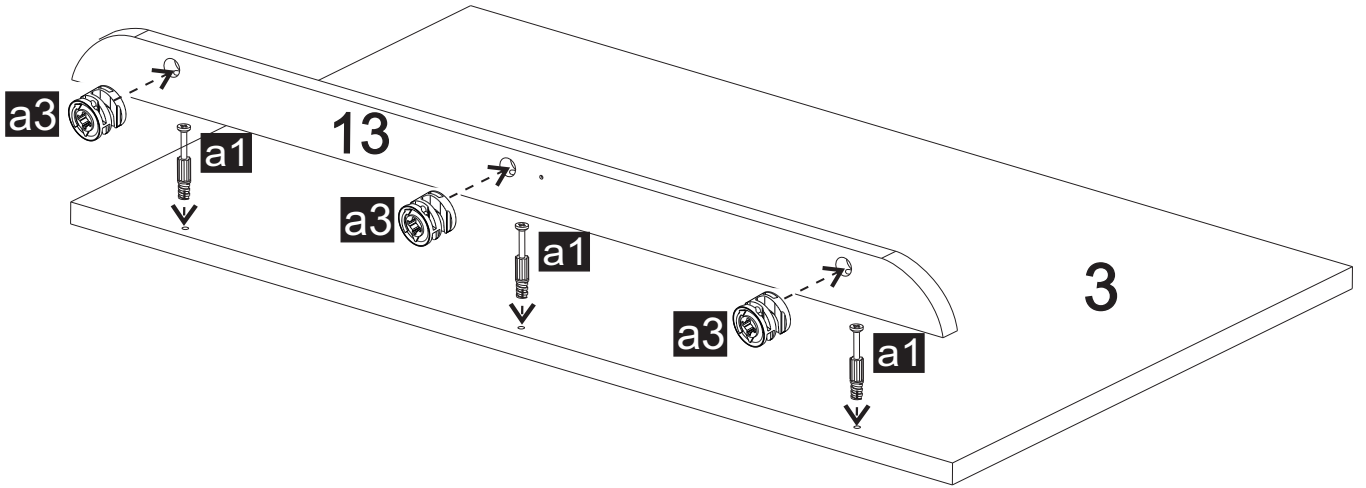
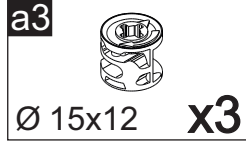
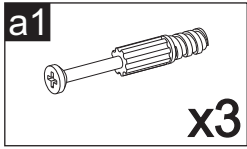

12

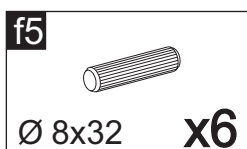
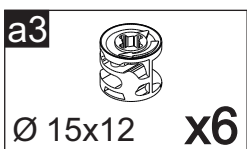
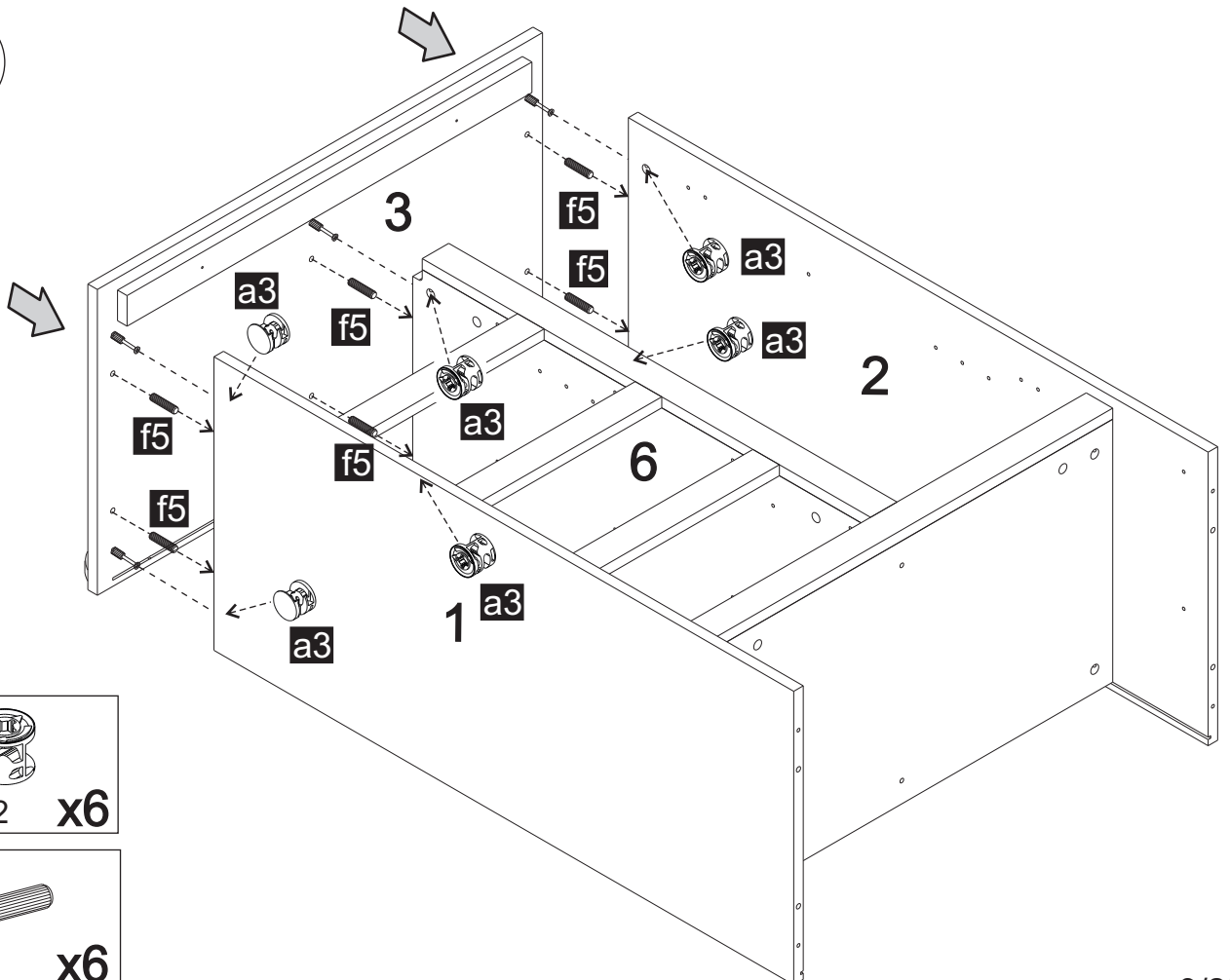

13

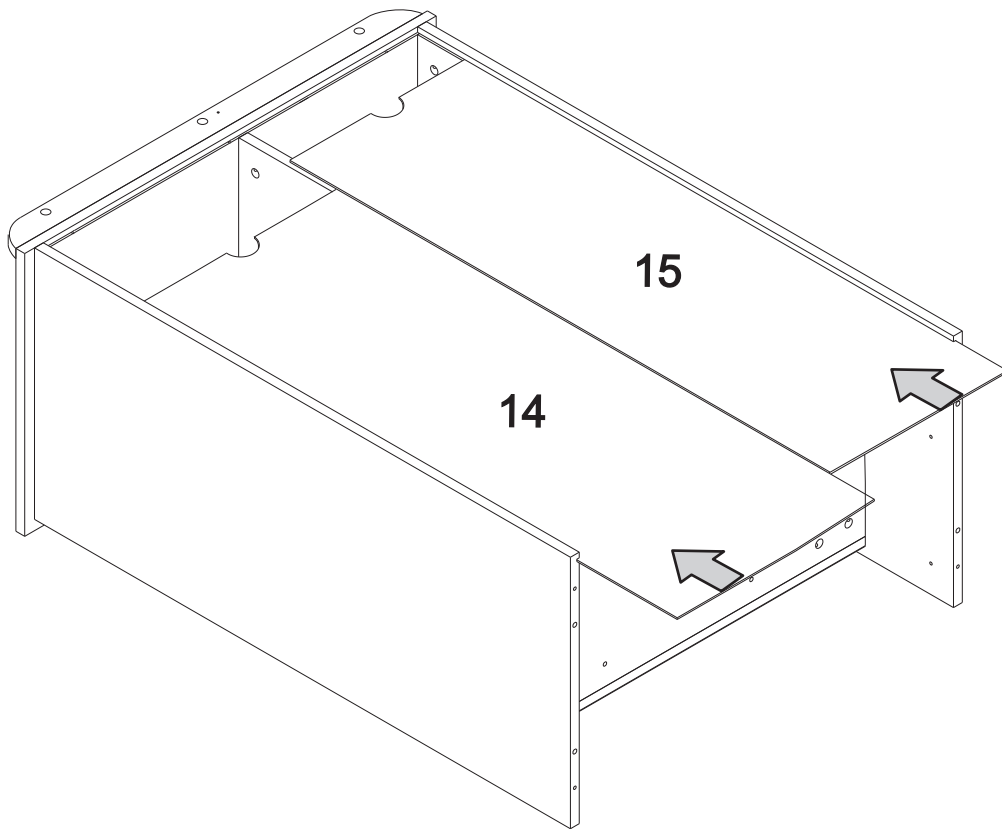

14

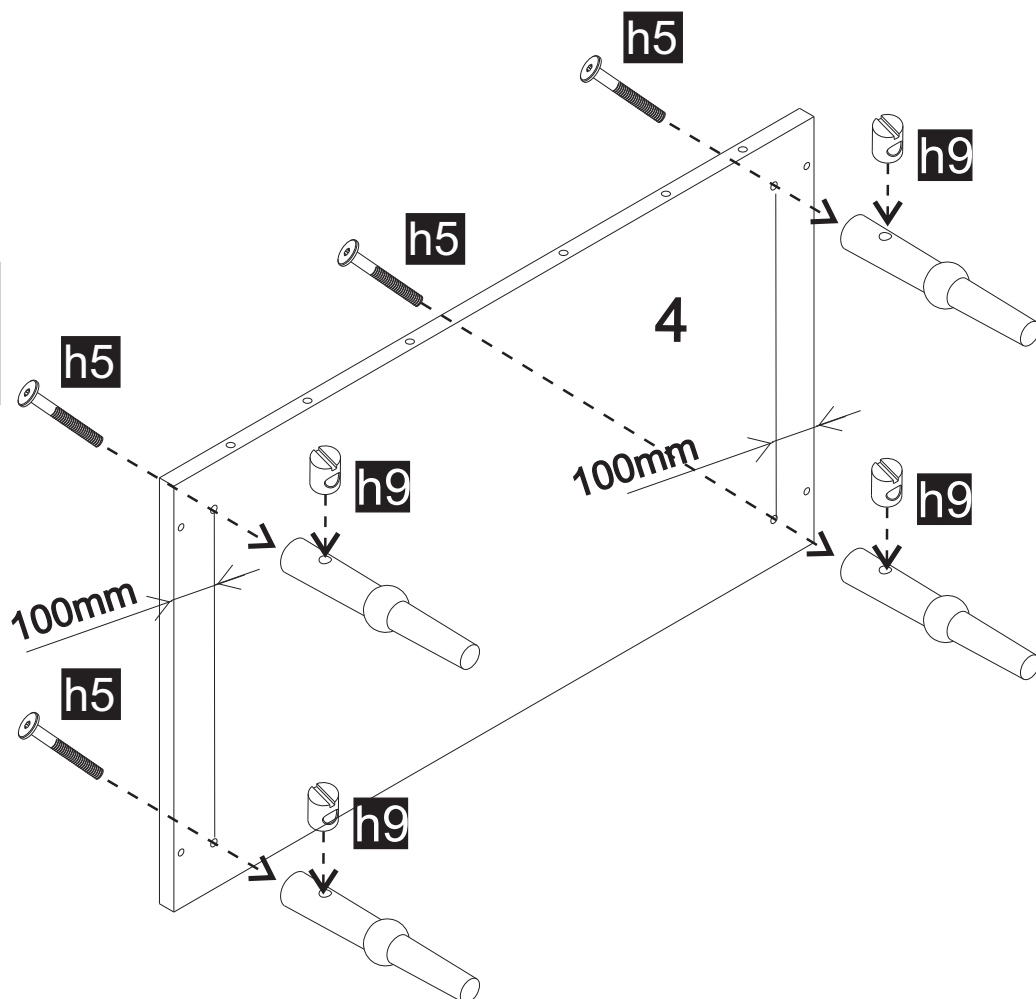
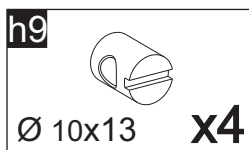
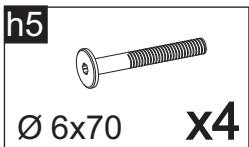

15

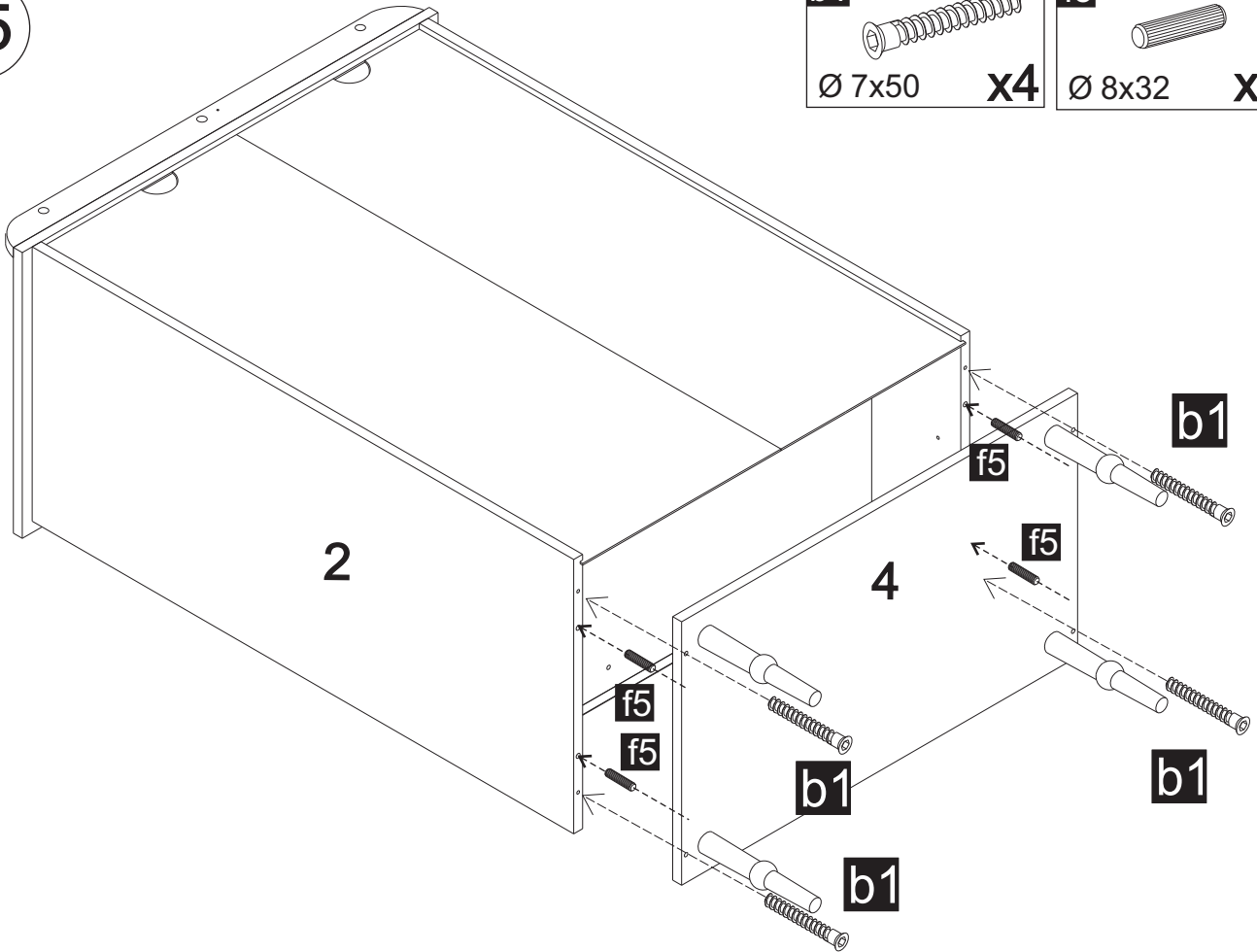
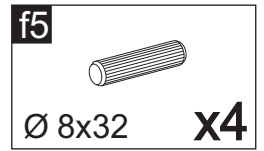
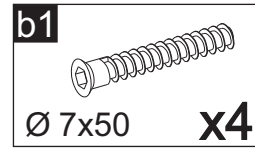

16

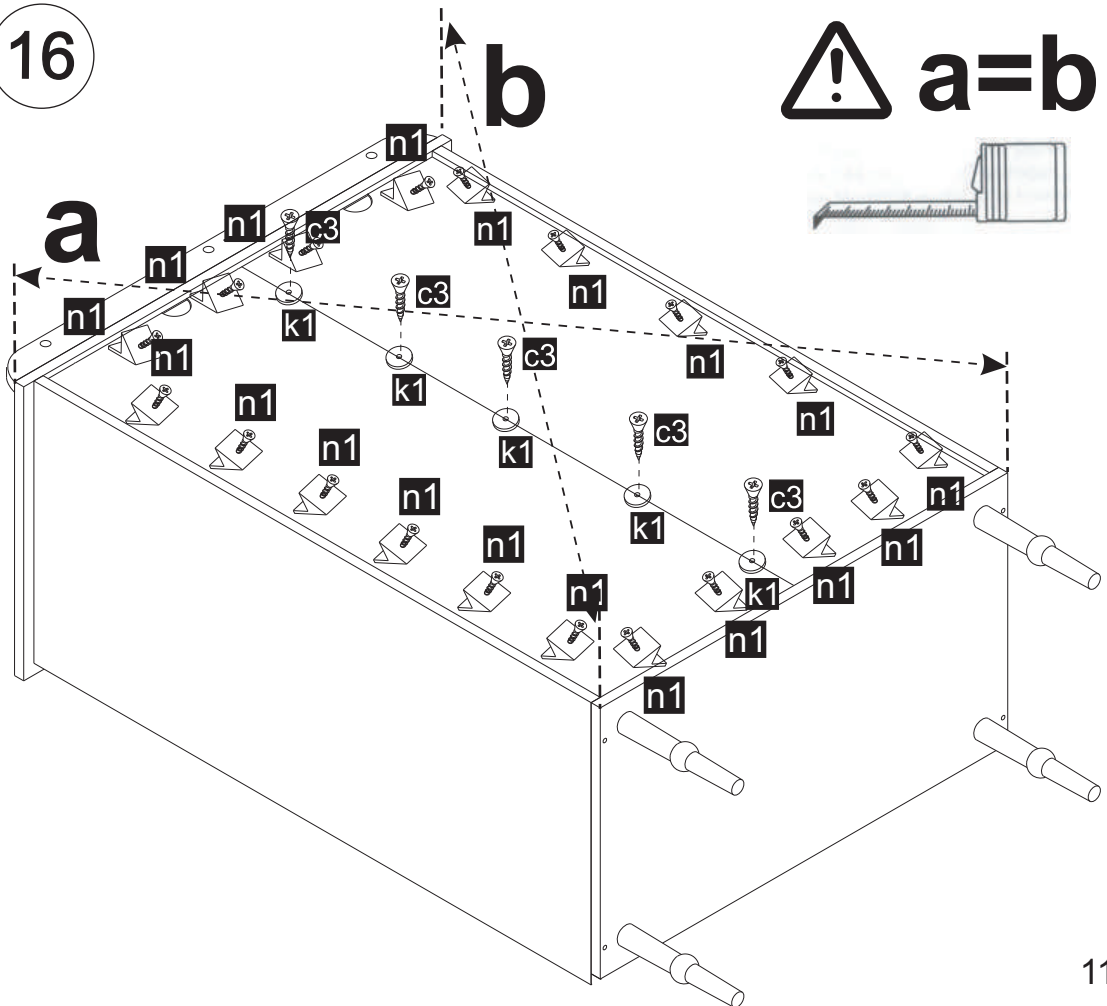
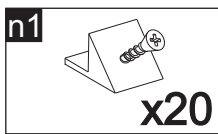
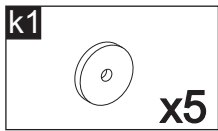
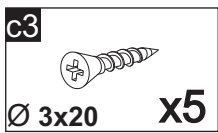

17

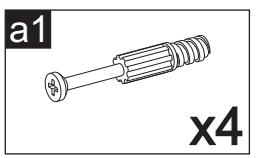
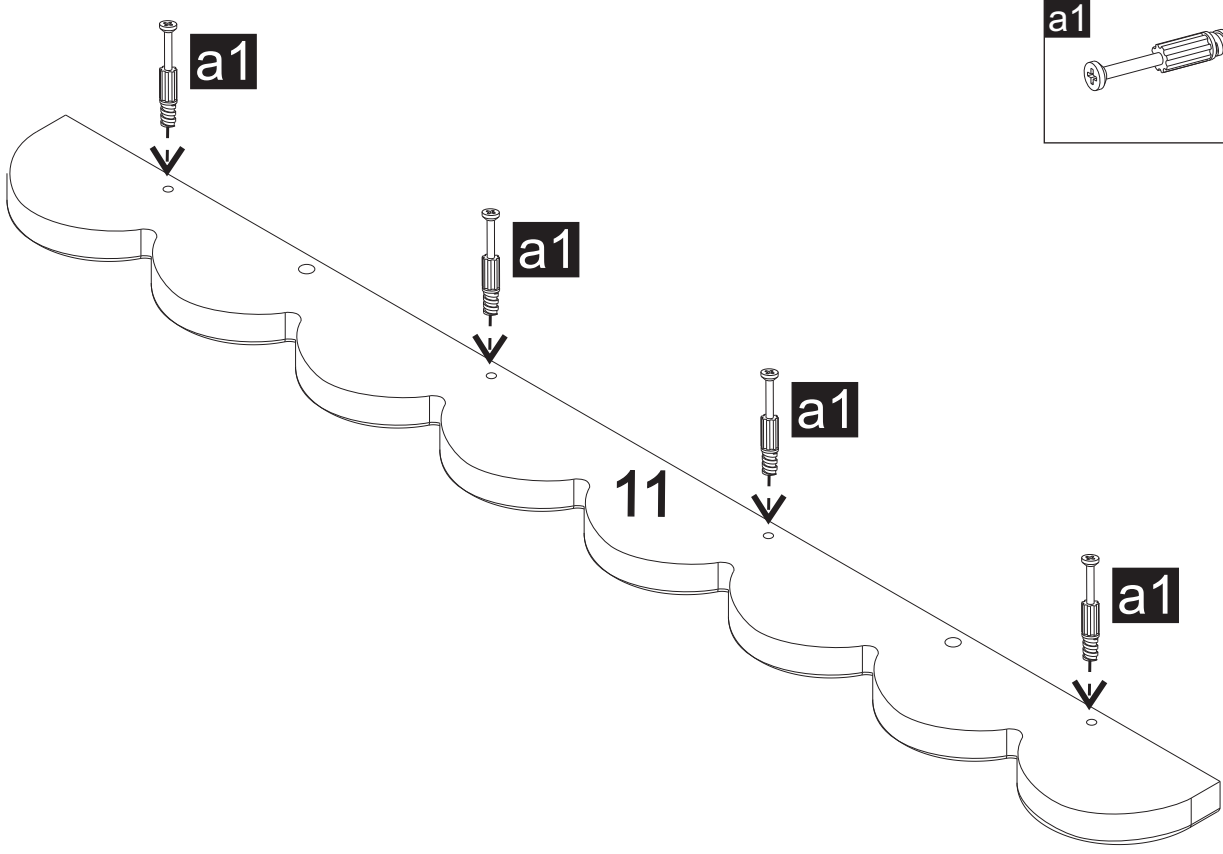

18

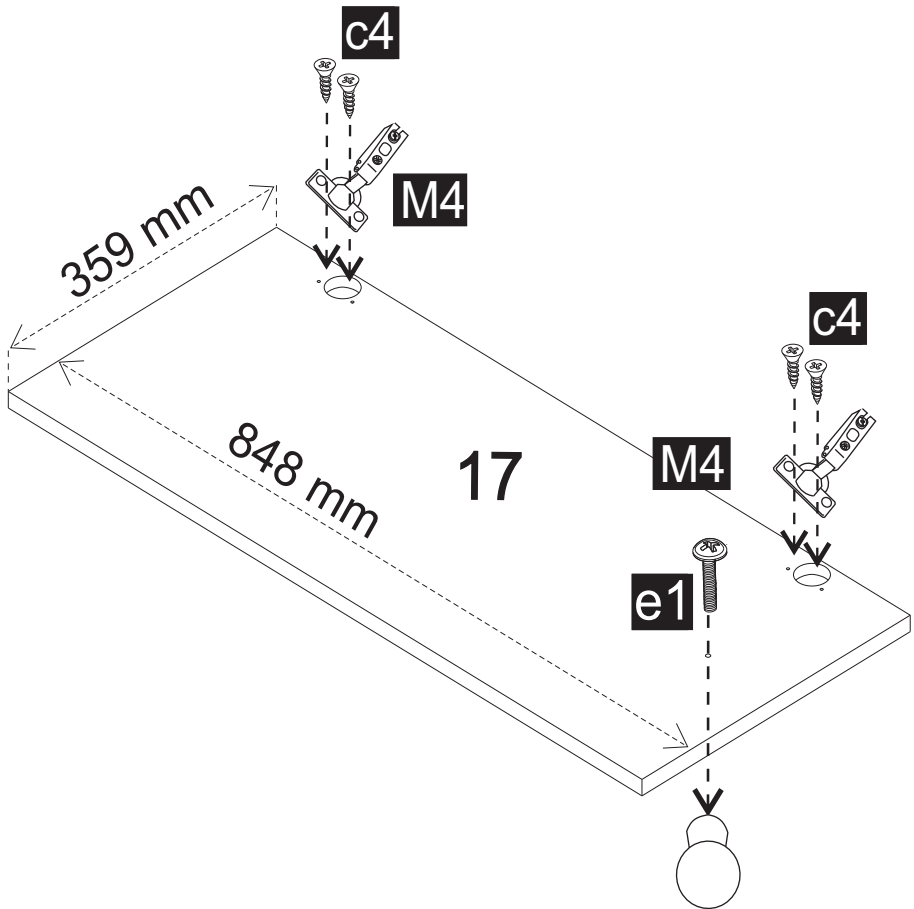
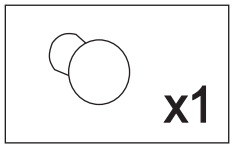
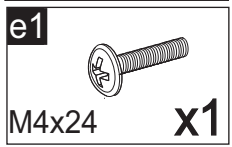
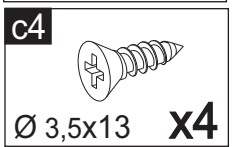
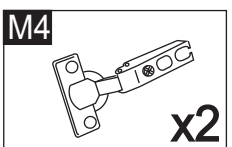

19

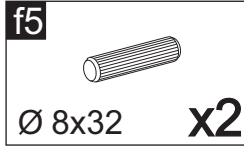
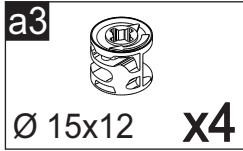
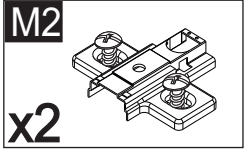

M2

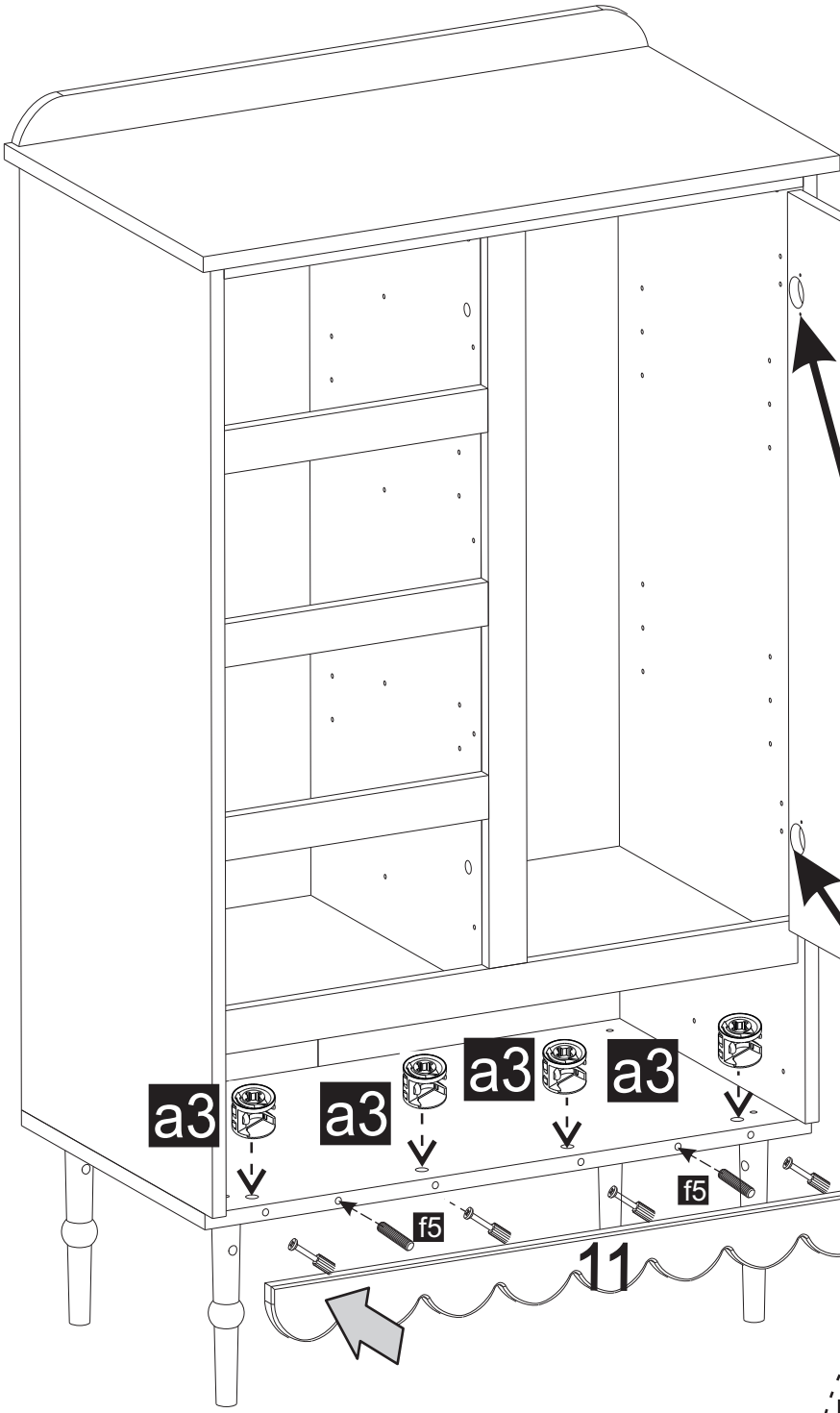
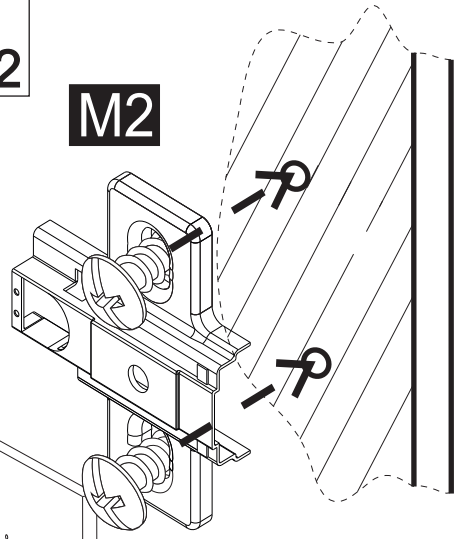

17

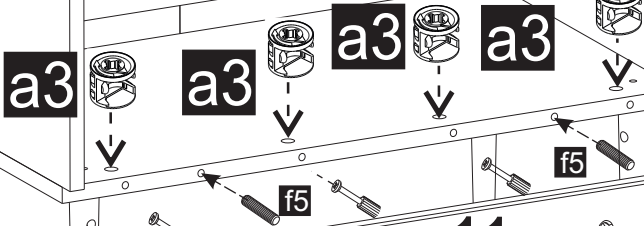

11

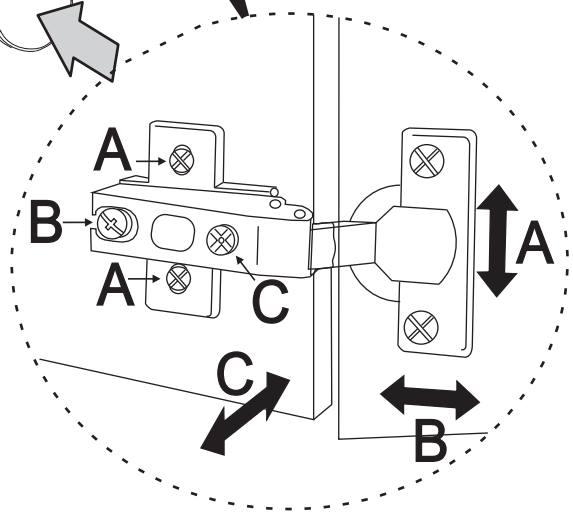

20

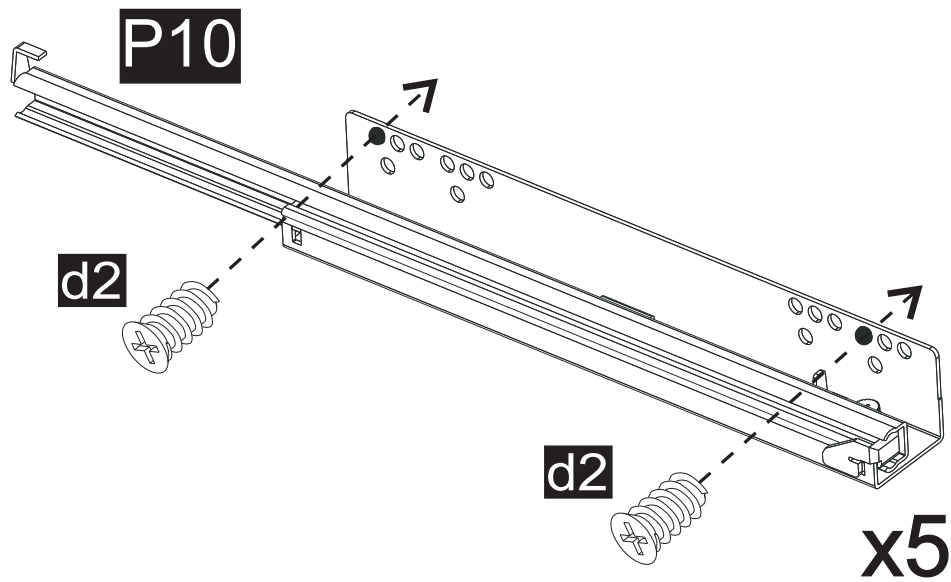
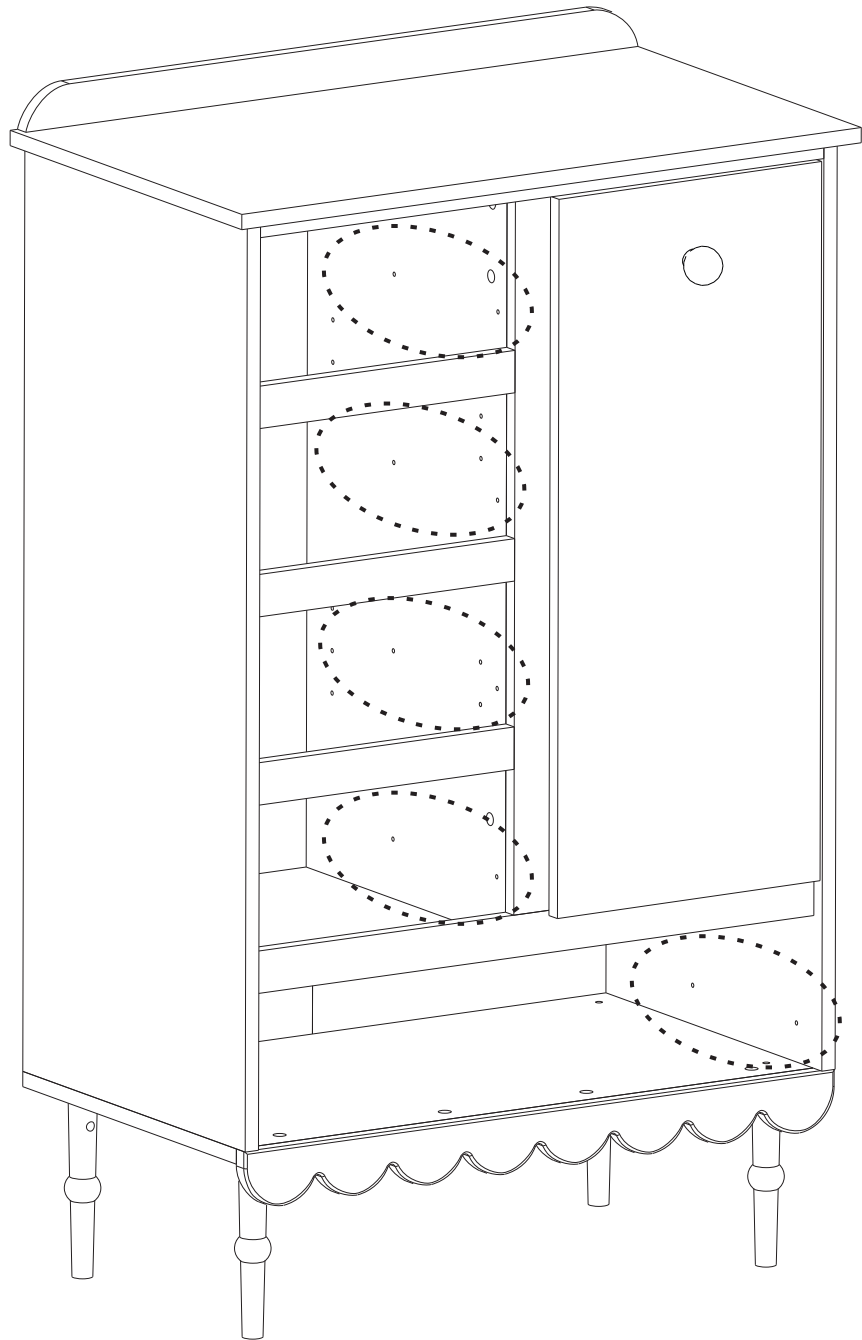
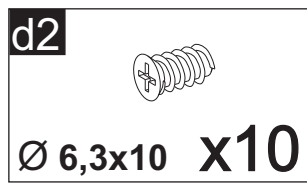
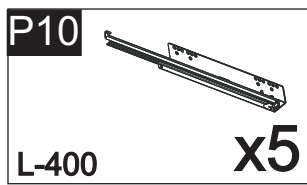

21

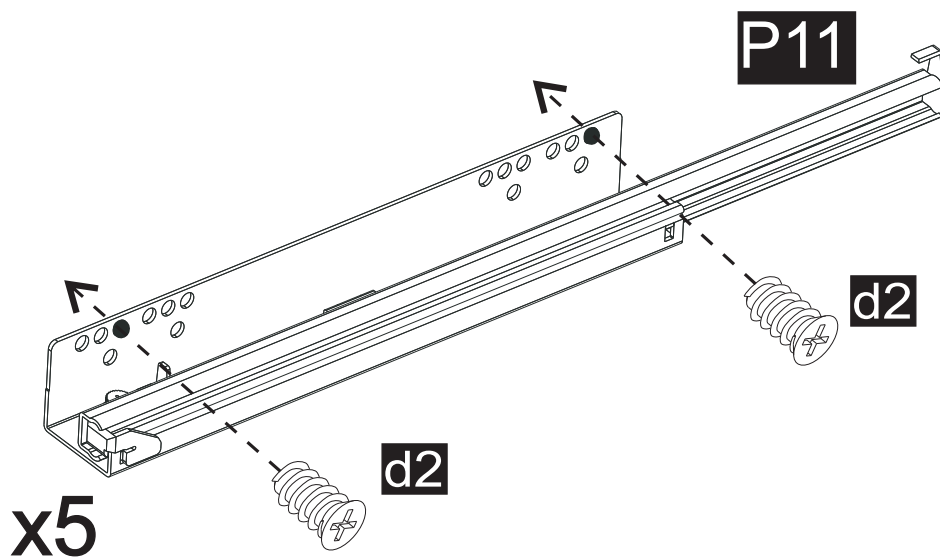
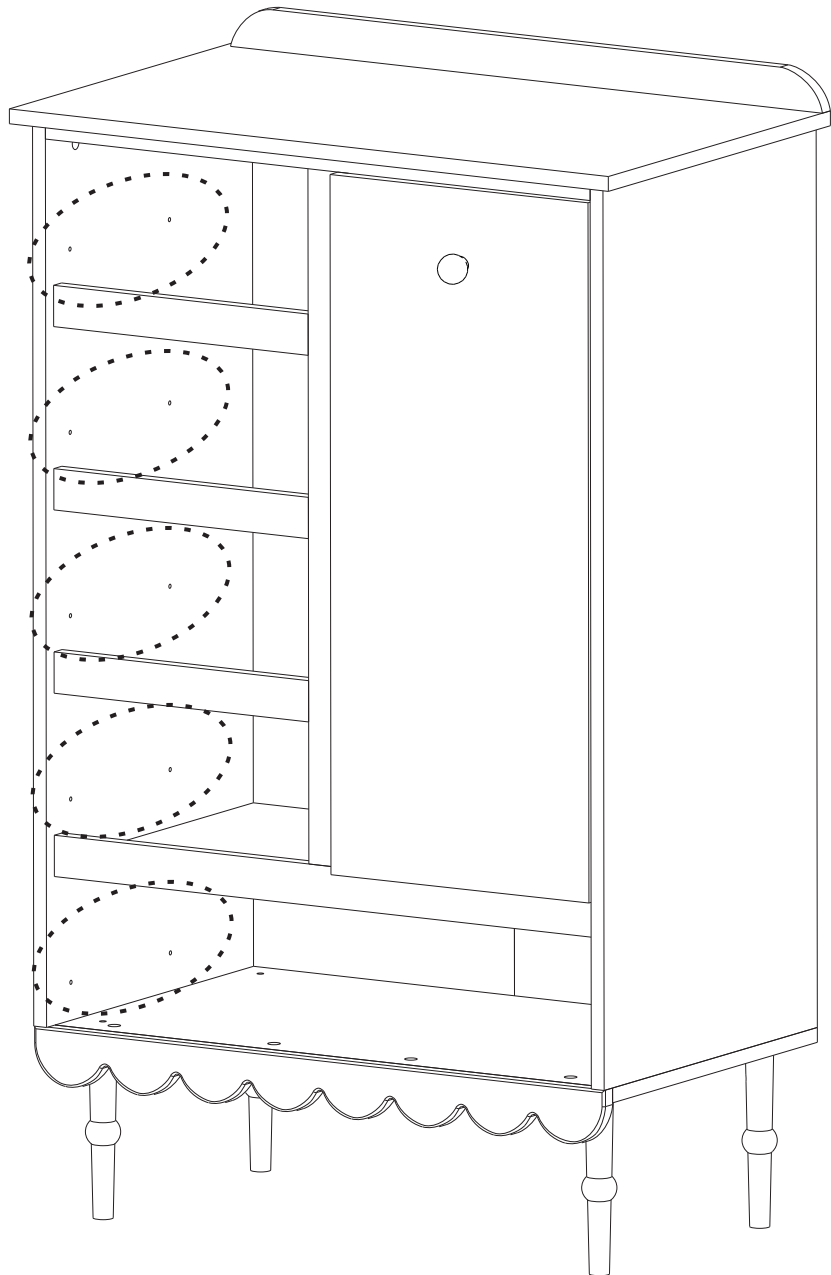
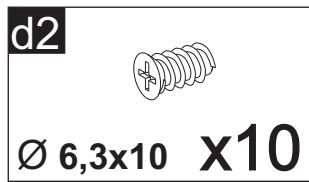
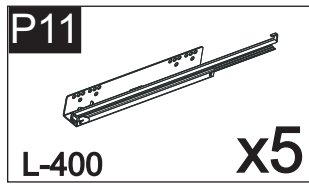

22

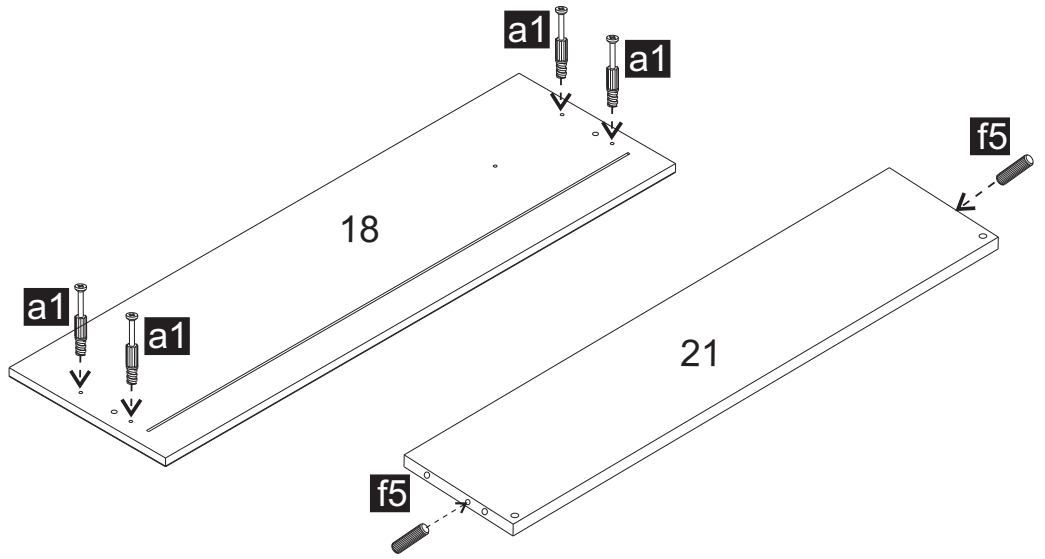
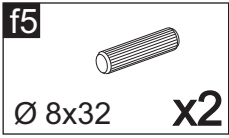
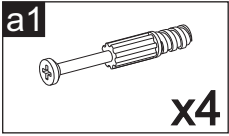

23

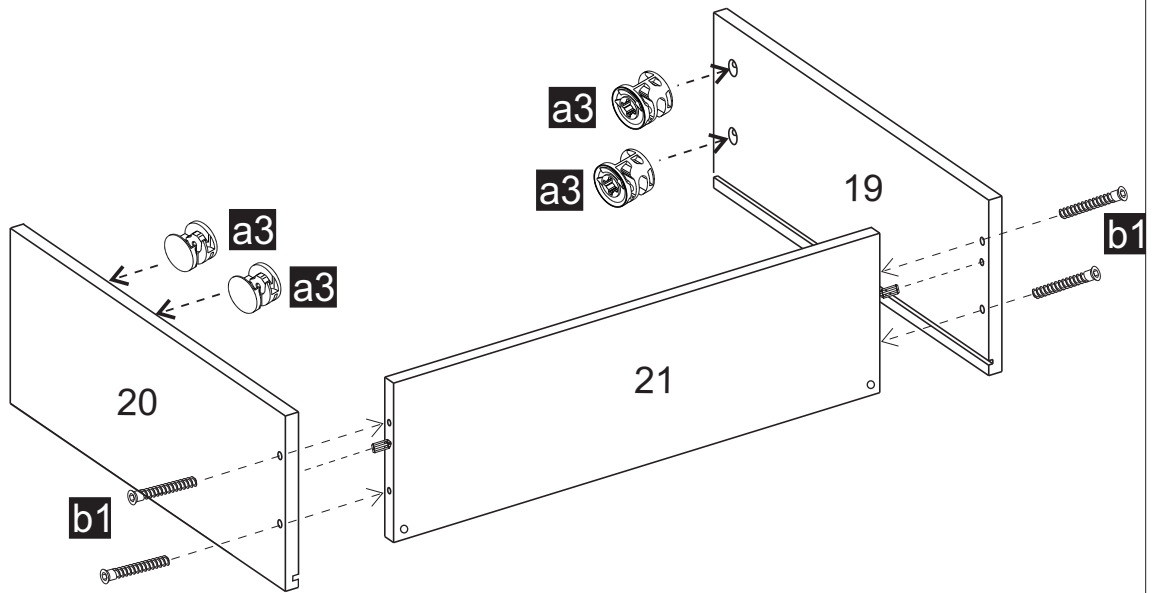
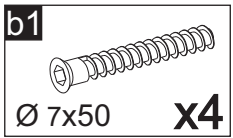
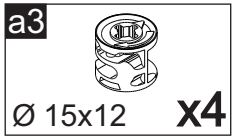

24

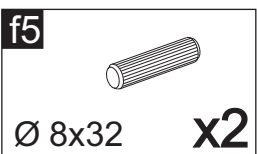
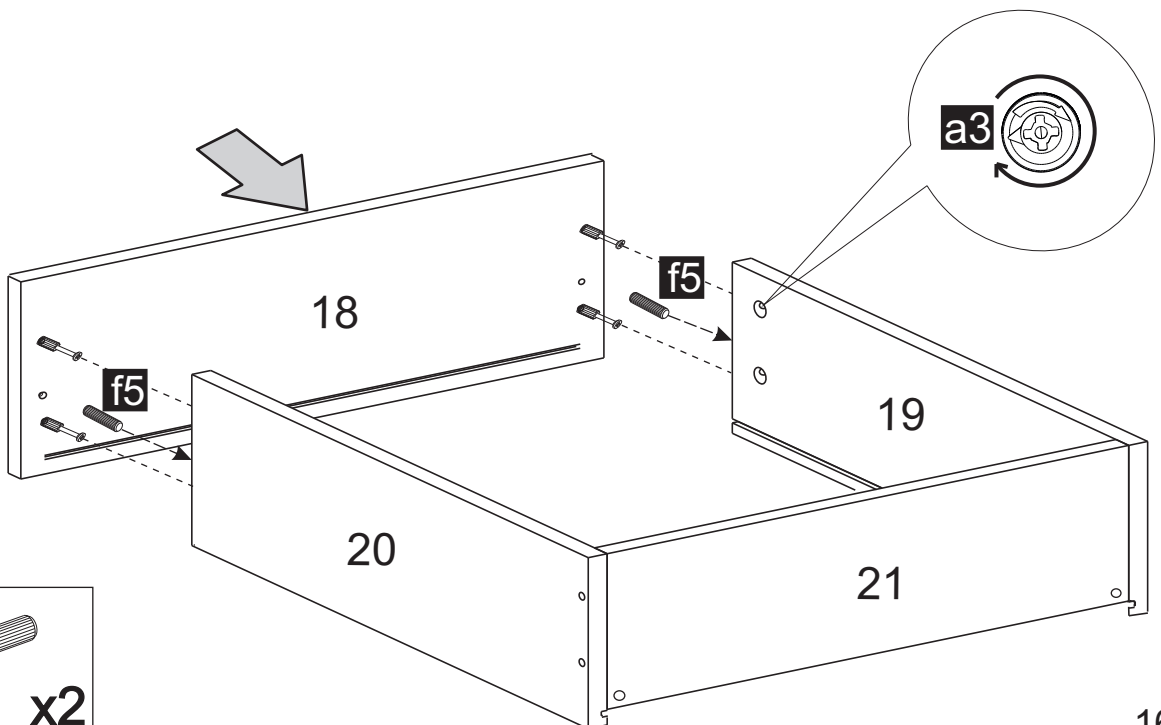

25

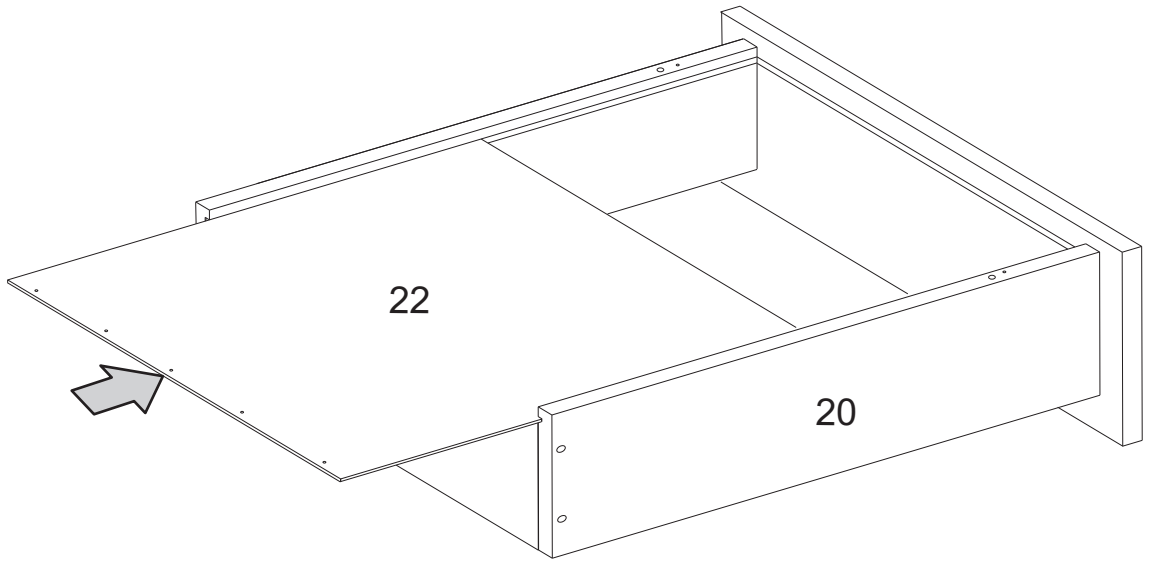

26

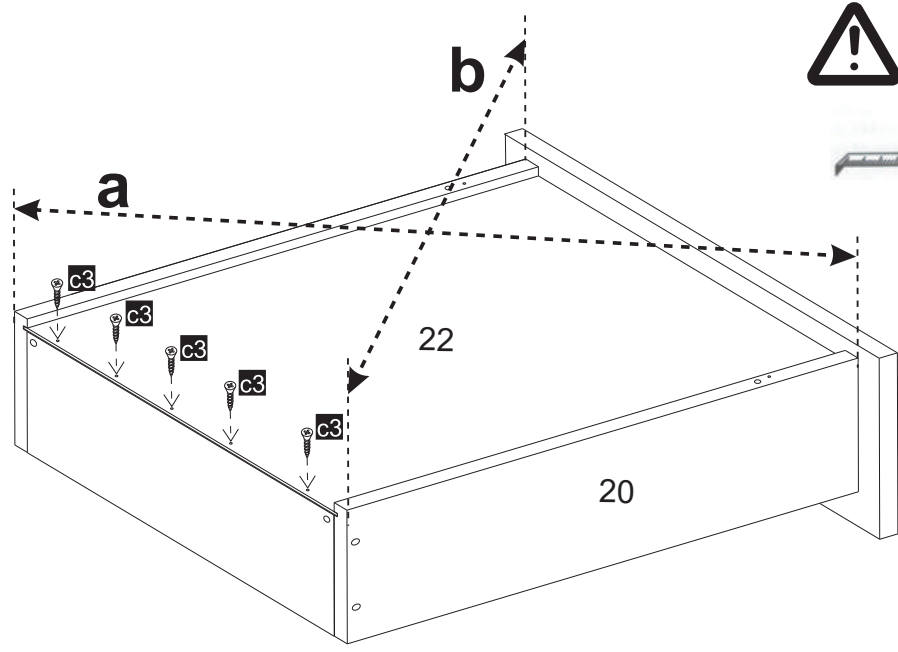
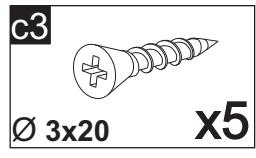

27

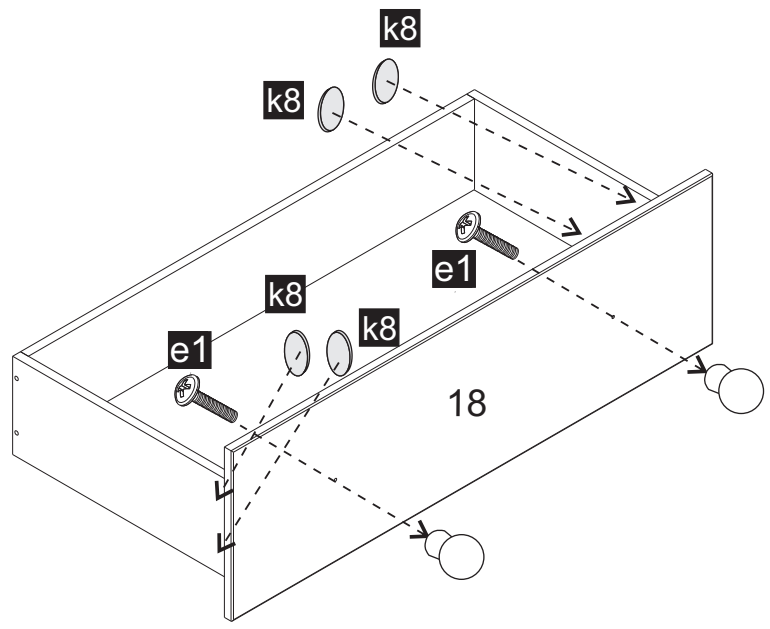
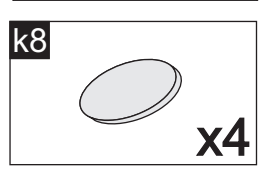
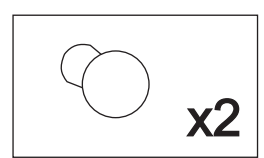
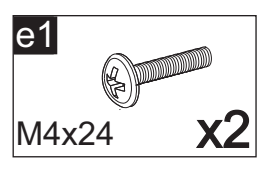

28 x4

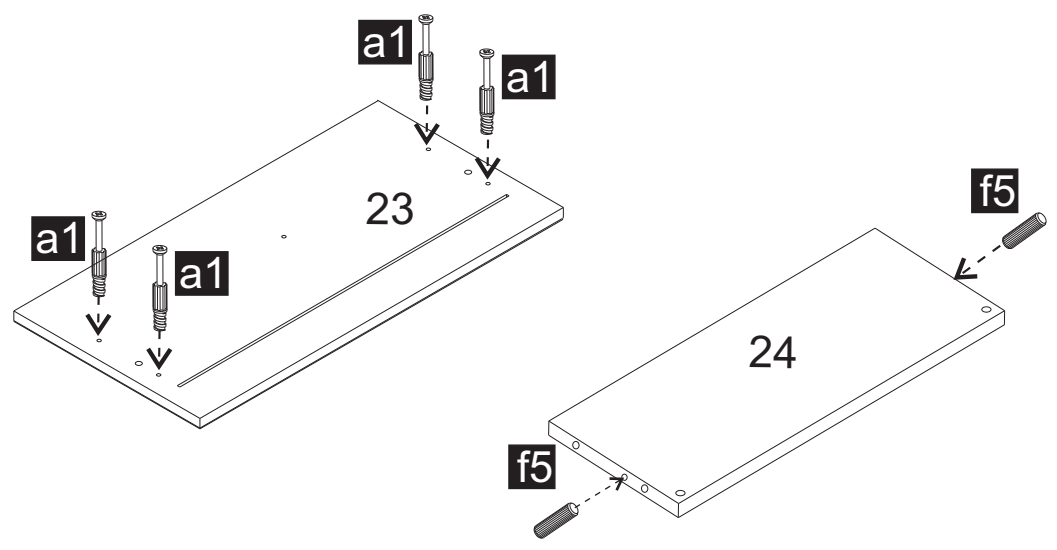
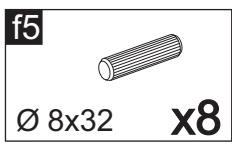
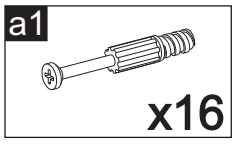

29 x4

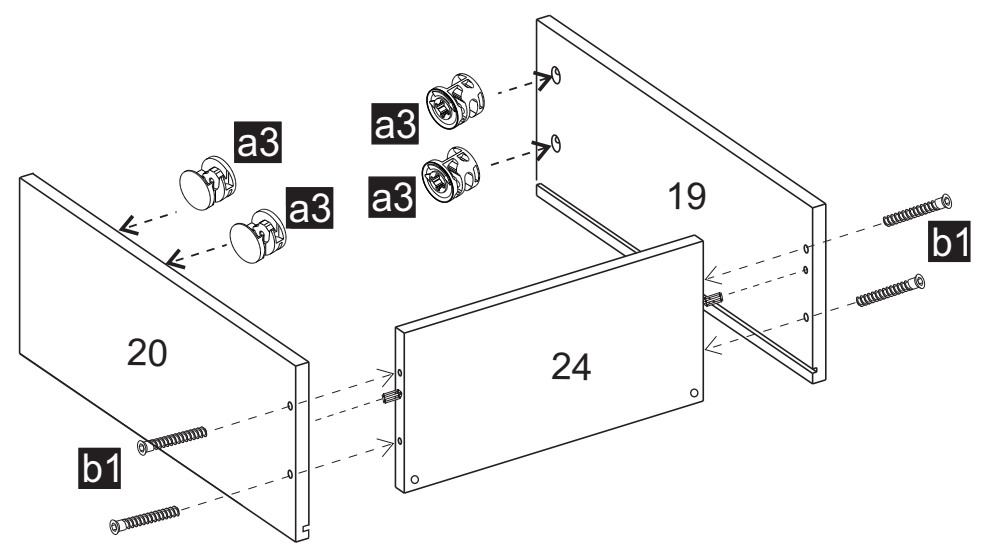
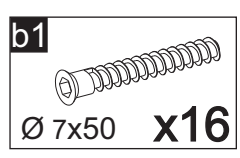
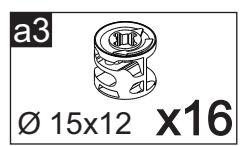

30 x4

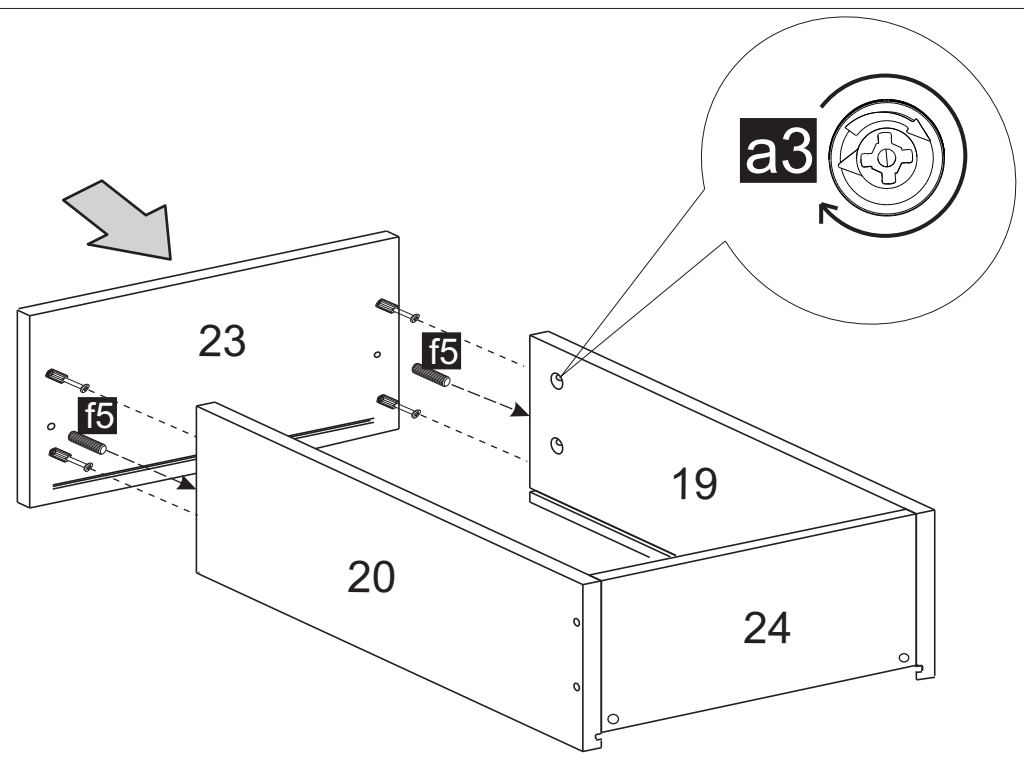
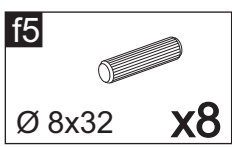

31 x4

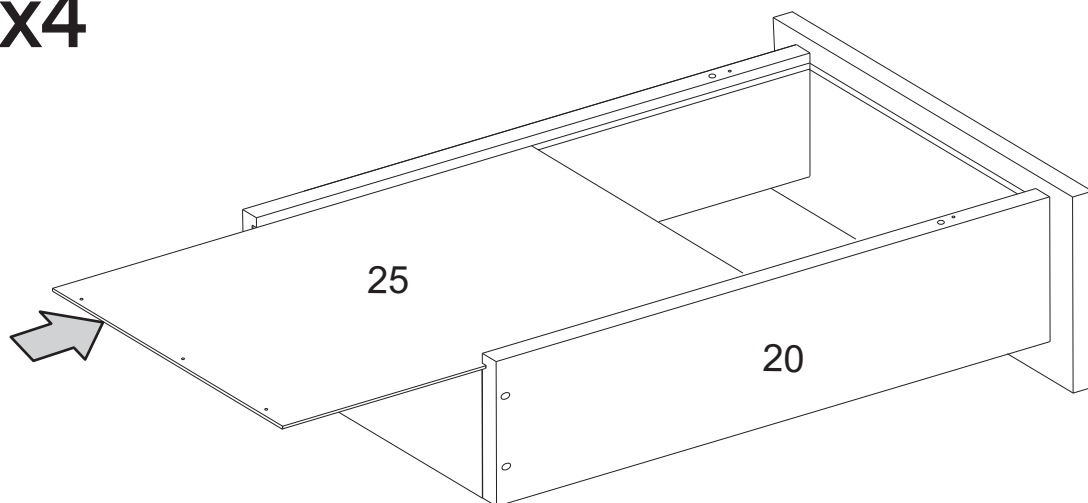

32 x4

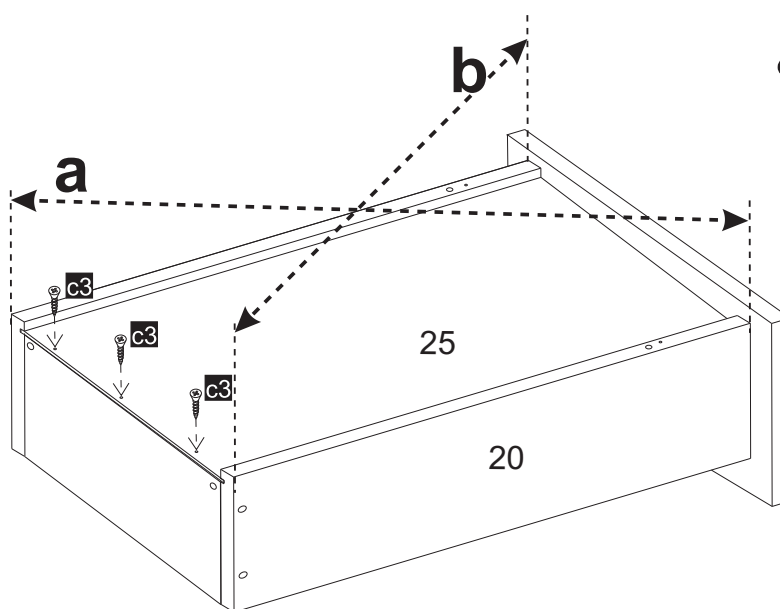
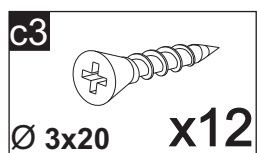

33 x4

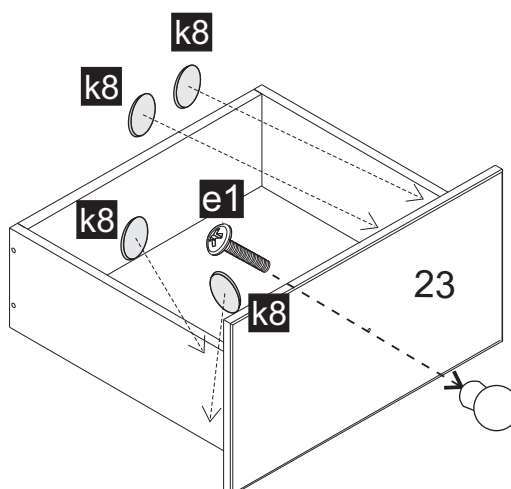
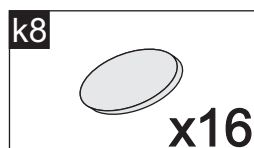
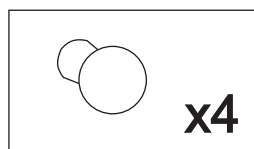
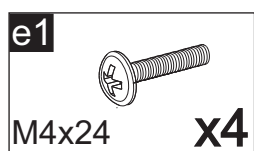



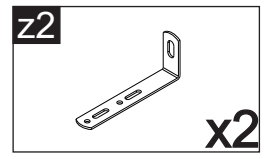
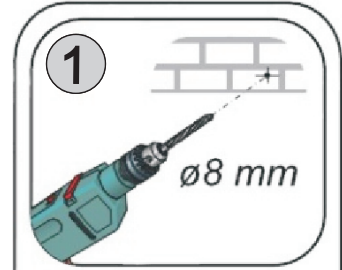
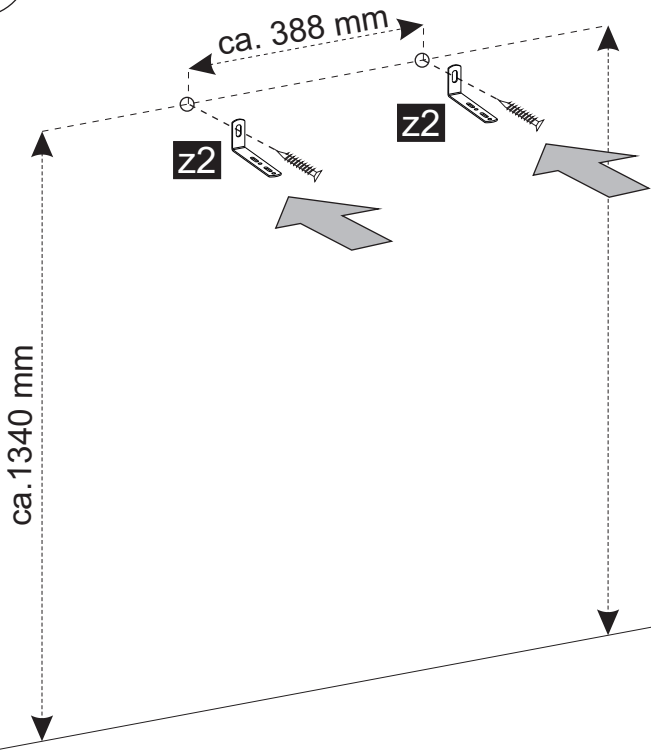

34

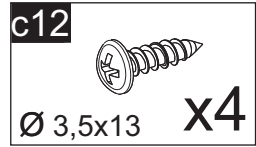
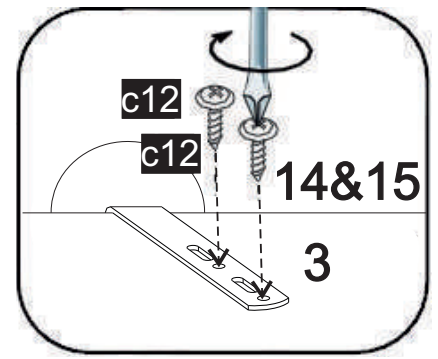
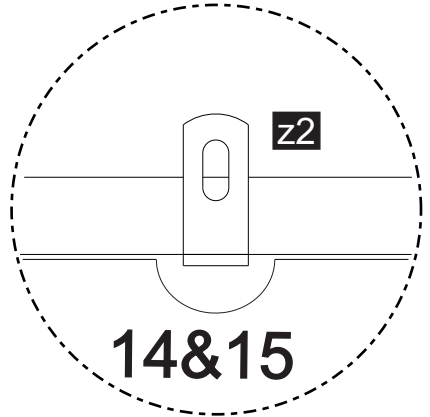
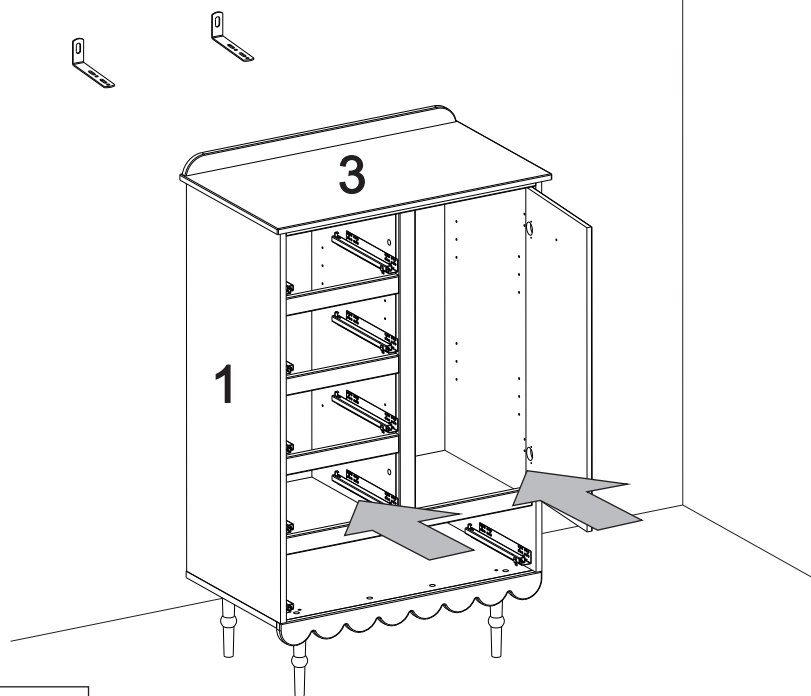

35



36 **c3**

 Ø 3x20 X10

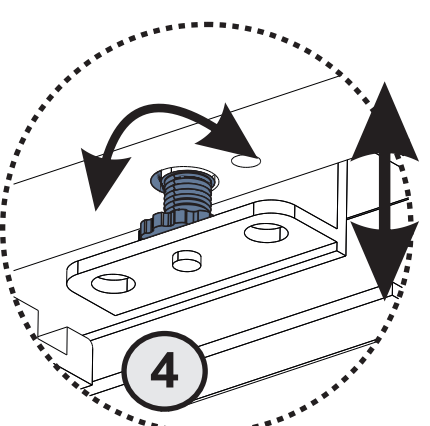
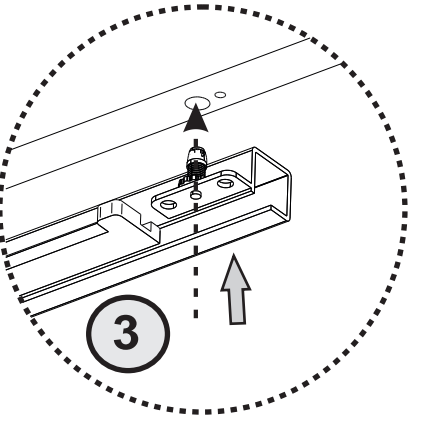
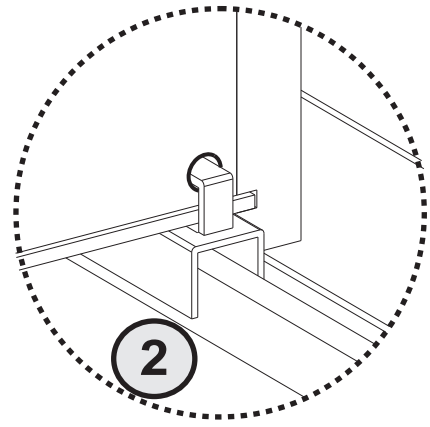
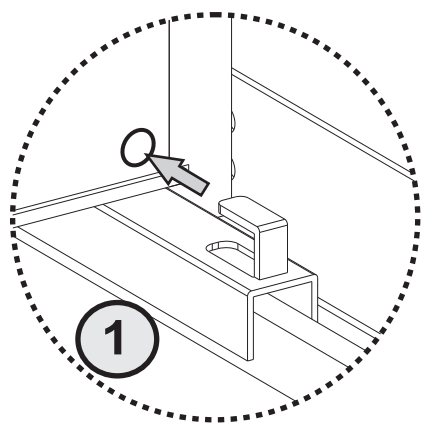
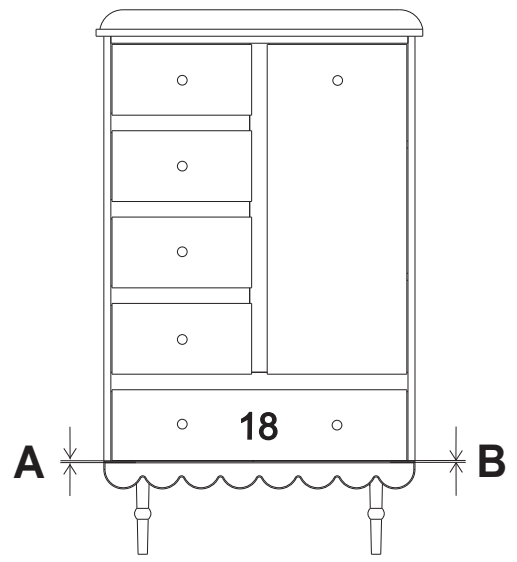
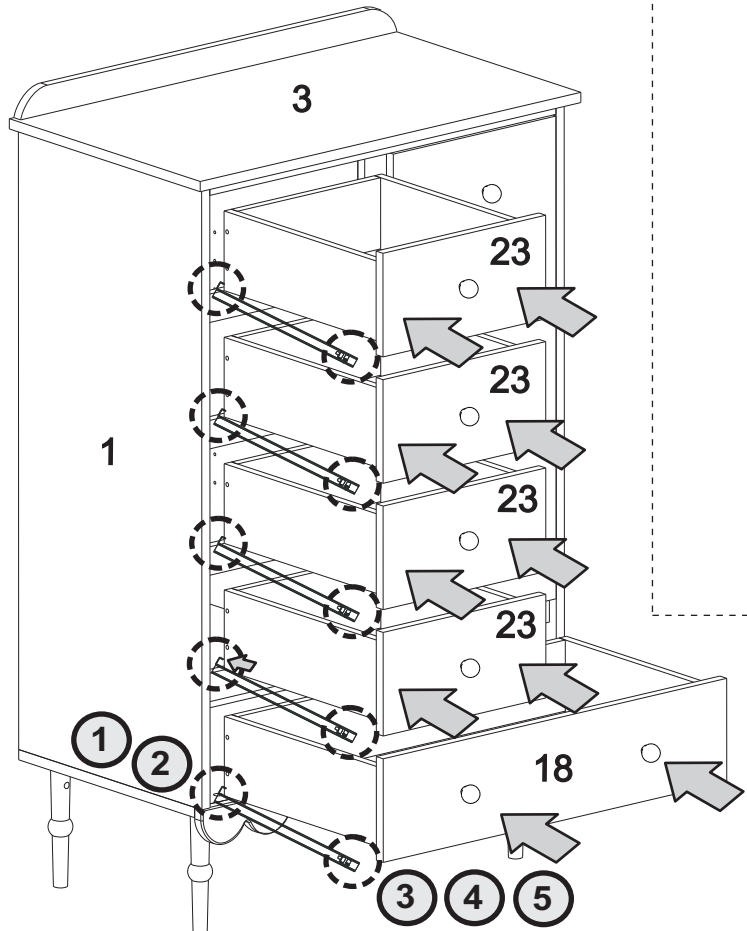
37
 A≠B
 +/-
 A=B

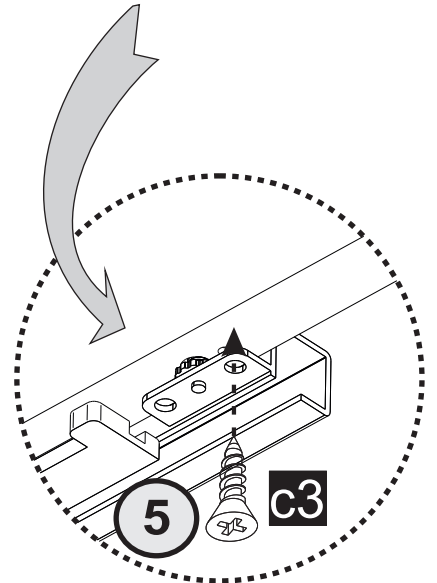

ATTENTION - IMPORTANT
UWAGA - WAŻNE



38

k9



x2



k9



x2

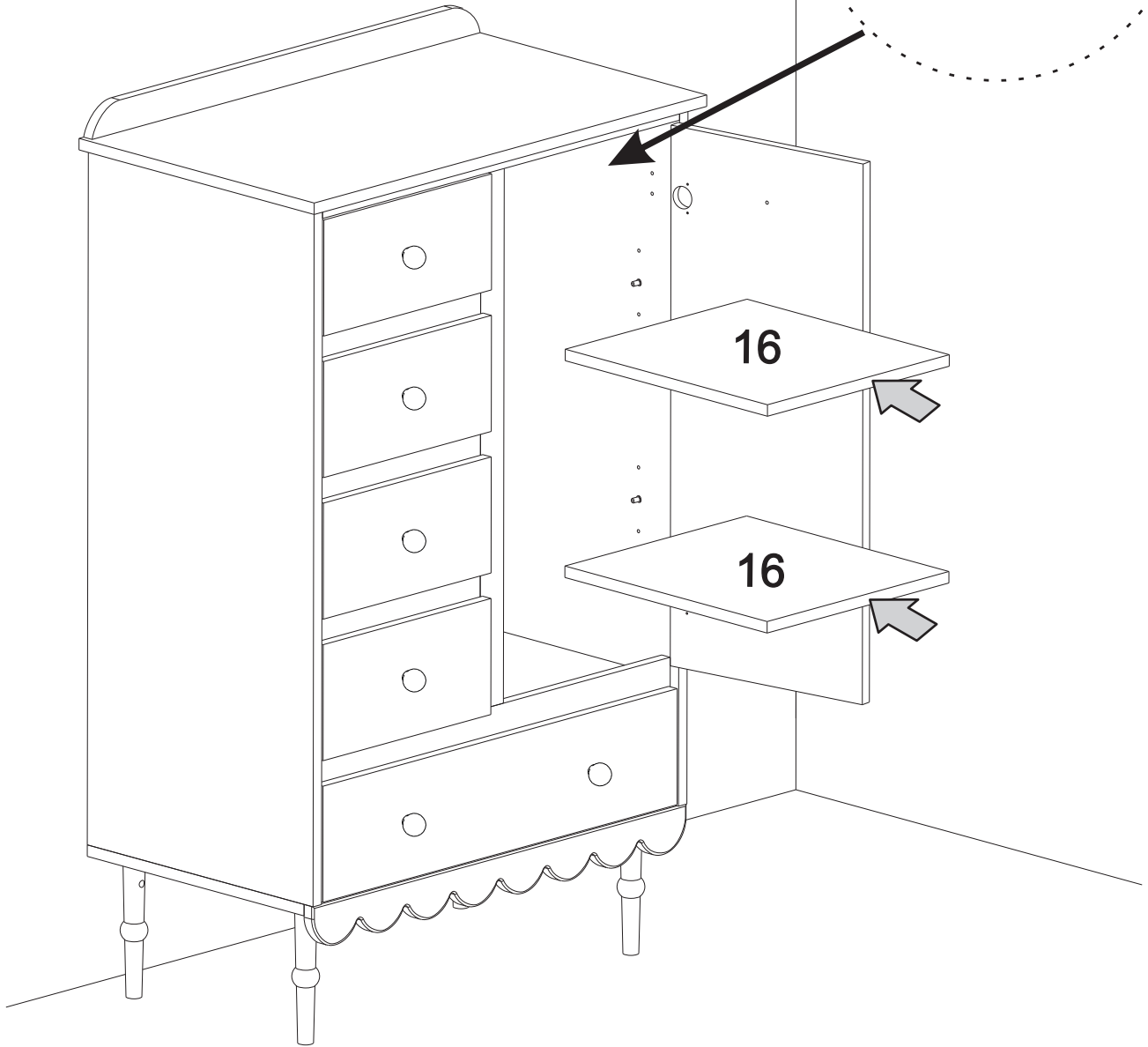

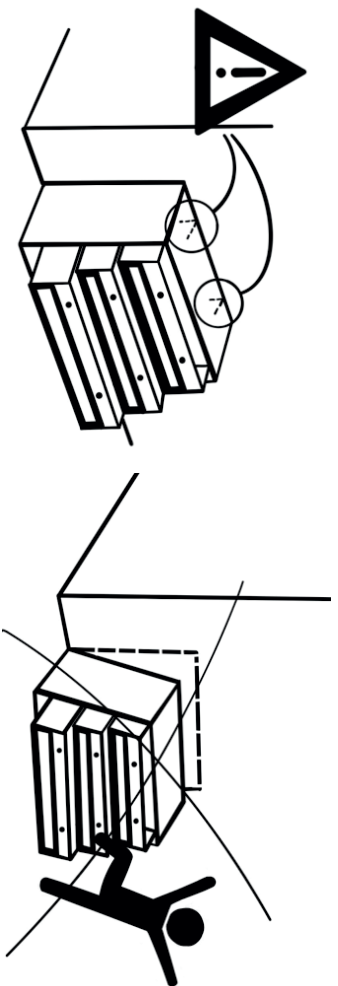

EN

Fasten it!

We all want our homes to be safe. Unfortunately, accidents can occur in homes where children are particularly vulnerable. The best way to prevent a piece of furniture from falling over is to attach it to the wall.

How to prevent accidents caused by furniture falling over?

- Fasten it! Furniture should be securely attached to the wall. Use the anti-tipping fixing attached to the product, as well as screws and dowels appropriate for the type of wall. Take a look at the attached guide, which will help you choose them.
- Never allow children to climb or hang on drawers, doors or shelves.

Fasten it! Wall mounting guide. Furniture should be securely attached to the wall.

Due to different wall types, the customer chooses the type of attachment for the wall. If the material from which the walls are made in your home is not included below or you have additional questions, contact the selected store with building materials.

Building material

1. Drywall or plaster wall with timber frame- fig.1
2. A drywall wall without a timber frame- fig.2
3. Brick wall:

- solid wall (fig. 3a)

- wall with empty space inside (fig. 3b)

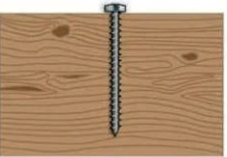

Figure 1



Figure 2



Figure 3a and 3b

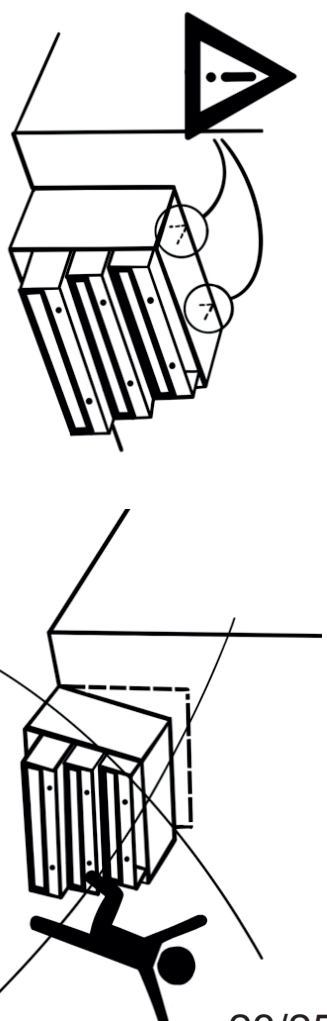

PL

Przymocuj to!

Wszyscy chcemy, żeby nasze domy były bezpieczne. Niestety w domach mogą zdarzyć się wypadki, na które szczególnie narażone są dzieci. Najlepszym sposobem, by zapobiec przewróceniu się mebla, jest przymocowanie go do ściany.

Jak zapobiec wypadkom spowodowanym przewróceniem się mebli?

- Przymocuj to! Meble należy bezpiecznie przymocować do ściany. Wykorzystaj mocowanie zapobiegające przewróceniu się mebla dołączone do produktu oraz śruby i kolki odpowiednie do danego typu ściany. Zajrzyj do załączonego poradnika, który pomoże Ci je dobrać.
- Nigdy nie pozwalaj dzieciom wspinać się lub wieszać na szufladach, drzwiczkach czy półkach.

Przymocuj to! Poradnik dotyczący mocowania do ściany. Meble należy bezpiecznie przymocować do ściany.

Ze względu na różne ściany klient sam dobiera rodzaj mocowania do danej ściany. Jeśli poniżej nie uwzględniono materiału, z którego wykonane są ściany w twoim domu lub masz dodatkowe pytania, skontaktuj się z wybranym sklepem z materiałami budowlanymi.

Materiał budowlany

1. Ściana suchej zabudowy lub gipsowa ze szkieletem drewnianym- rys.1
2. Ściana suchej zabudowy bez szkieletu drewnianego- rys.2
3. Ściana murowana:

- ściana lita (rys. 3a)

- ściana z pustą przestrzenią wewnątrz (rys. 3b)

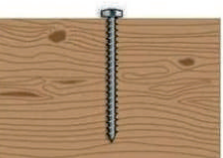

Rysunek 1



Rysunek 2



Rysunek 3a i 3b



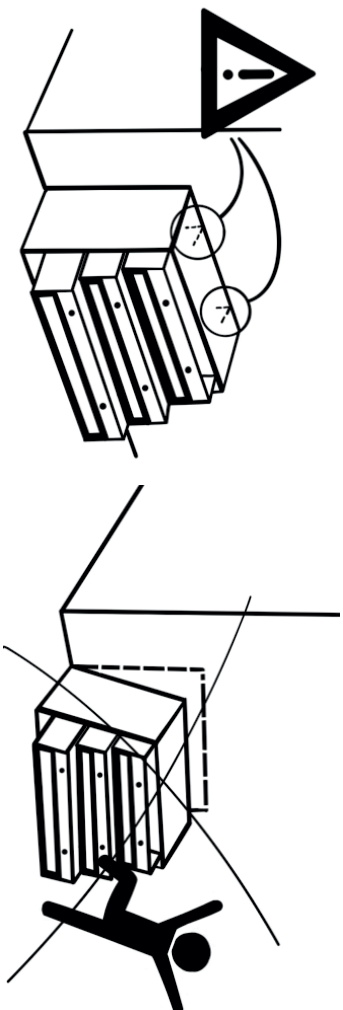

ES

¡Abrochalo!

Todos queremos que nuestras casas sean seguras. Por desgracia, los accidentes pueden ocurrir en hogares donde los niños son especialmente vulnerables. La mejor forma de evitar que un mueble se caiga es fijarlo a la pared.

¿Cómo evitar los accidentes causados por la caída de muebles?

- Sujétalo Los muebles deben estar bien sujetos a la pared. Utilice las fijaciones antivuelco adjuntas al producto, así como tornillos y tacos adecuados al tipo de pared. Eche un vistazo a la guía adjunta, que le ayudará a elegirlos.

Nunca permita que los niños trepen o se cuelguen de cajones, puertas o estantes.

Fijación Guía de montaje en pared. Los muebles deben estar bien sujetos a la pared.

Debido a los diferentes tipos de pared, el cliente elige el tipo de fijación para la pared. Si el material del que están hechas las paredes en su casa no se incluye a continuación o tiene preguntas adicionales, póngase en contacto con la tienda seleccionada con materiales de construcción.

Material de construcción

1. Pared de yeso o escayola con marco de madera- fig. 1
2. Una pared de cartón yeso sin marco de madera- fig.2
3. Pared de ladrillo:

- pared sólida (fig. 3a)
- pared con espacio vacío en el interior (fig. 3b)



Figura 1



Figura 2

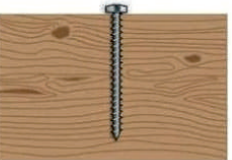

figuras 3a y 3b



FR

Réparez-la !

Nous voulons tous que nos maisons soient sûres. Malheureusement, des accidents peuvent survenir dans les maisons et les enfants y sont particulièrement vulnérables. La meilleure façon d'empêcher un meuble de tomber est de le fixer au mur.

Comment prévenir les accidents dus aux chutes de meubles ?

- Fixez-le ! Fixez solidement le meuble au mur. Utilisez les fixations anti-basculement fournies avec le produit et les vis et chevilles adaptées à votre type de mur. Consultez le guide ci-joint pour vous aider à les choisir.

Ne laissez jamais les enfants grimper ou s'accrocher aux shufflads, aux portes ou aux étagères.

Fixez-le ! Un guide pour la fixation au mur. Fixer solidement des meubles au mur.

En raison de la diversité des murs, le client choisit lui-même le type de fixation pour le mur en question. Si le matériau du mur de votre maison veuillez contacter le magasin de matériaux de construction de votre choix.

Matériaux de construction

1. Cloison sèche ou en plâtre avec ossature en bois - fig. 1
2. cloisons sèches sans ossature bois - fig.2
3. mur en maçonnerie :

- mur plein (Fig. 3a)
- mur avec espace vide à l'intérieur (Fig. 3b)

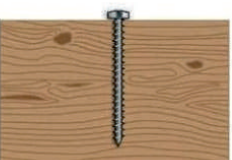

figure 1

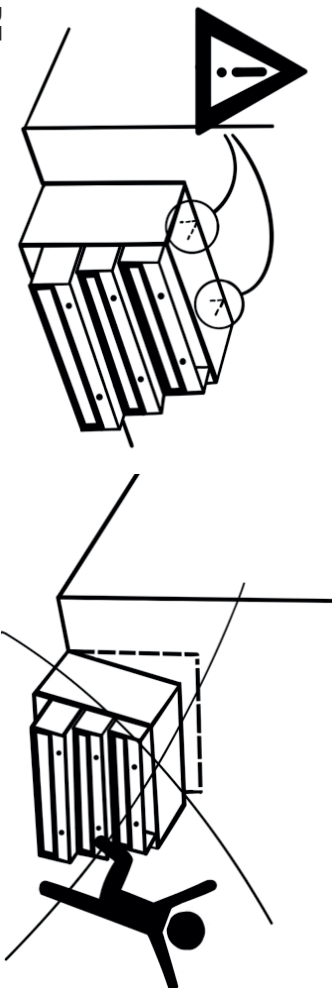

figure 2



figures 3a et 3b





DE

Reparieren Sie es!

Wir alle wollen, dass unser Zuhause sicher ist. Leider können sich Unfälle in Wohnungen ereignen, in denen Kinder besonders gefährdet sind. Der beste Weg, um zu verhindern, dass ein Möbelstück umkippt, ist, es an der Wand zu befestigen.

Wie lassen sich Unfälle durch umstürzende Möbel vermeiden?

- Befestigen Sie es! Die Möbel müssen sicher an der Wand befestigt werden. Verwenden Sie die dem Produkt beiliegende Kippsicherung sowie für die Art der Wand geeignete Schrauben und Dübel. Die beigefügte Anleitung hilft Ihnen bei der Auswahl.
- Erlauben Sie Kindern niemals, auf Schubladen, Türen oder Regale zu klettern oder sich daran aufzuhängen.

Befestigen Sie es! Anleitung zur Wandmontage. Die Möbel sollten sicher an der Wand befestigt werden.

Aufgrund der unterschiedlichen Wandtypen wählt der Kunde die Art, der Befestigung an der Wand. Wenn das Material, aus dem die Wände in Ihrem Haus bestehen, unten nicht aufgeführt ist oder Sie zusätzliche Fragen haben, wenden Sie sich an das ausgewählte Geschäft mit Baumaterialien.

Baumaterial

1. Trockenbau- oder Gipswand mit Holzrahmen - fig.1
2. Eine Trockenbauwand ohne Holzrahmen - fig.2
3. Backsteinmauer:
 - massive Wand (Ziff. 3a)
 - Wand mit leerem Innenraum (Ziff. 3b)



Abbildung 1



Abbildung 2

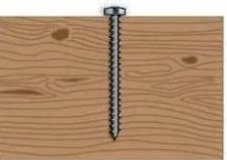

Abbildungen 3a und 3b

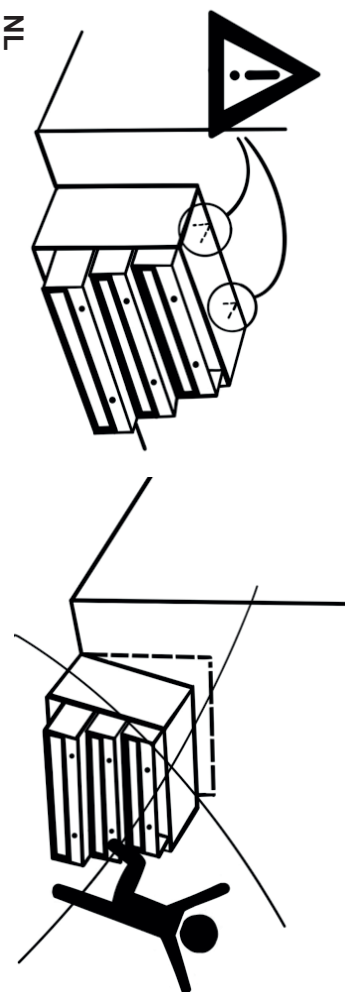

NL

Repareer het!

We willen allemaal dat onze huizen veilig zijn. Helaas kunnen er thuis ongelukken gebeuren en kinderen zijn daar bijzonder kwetsbaar voor. De beste manier om te voorkomen dat een meubelstuk omvalt, is om het aan de muur te bevestigen.

Hoe voorkom je ongelukken door omvallend meubilair?

- Bevestigen! Bevestig de meubels stevig aan de muur. Gebruik de meegeleverde anti-kantelbevestigingen en de schroeven en pluggen die geschikt zijn voor jouw muurtype. Kijk in de bijgevoegde gids om je te helpen deze te kiezen.
- Laat kinderen nooit op schalen, deuren of planken klimmen of eraan hangen.

Bevestigen! Een gids voor bevestiging aan de muur. Bevestig meubels stevig aan de muur.

Vanwege de verschillende muren kiest de klant zelf het type bevestiging voor de muur in kwestie. Als het muurmateriaal van je huis hieronder niet wordt vermeld, of als je nog vragen hebt, neem dan contact op met de bouwmaterialenhandel van je keuze.

Bouwmaterial

1. Gipsplaat of gipswand met houten frame - afb. 1
2. Gipsplaat zonder houtskelet - afb. 2
3. Gemetselde muur:
 - massieve wand (Fig. 3a)
 - muur met lege ruimte binnenin (Fig. 3b)

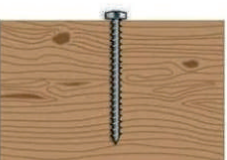

Figuur 1



Figuur 2



Figuren 3a en 3b

