

# ASSEMBLY INSTRUCTION

WF315868/WF315884  
WF315885/WF315886  
WF315887/WF315888

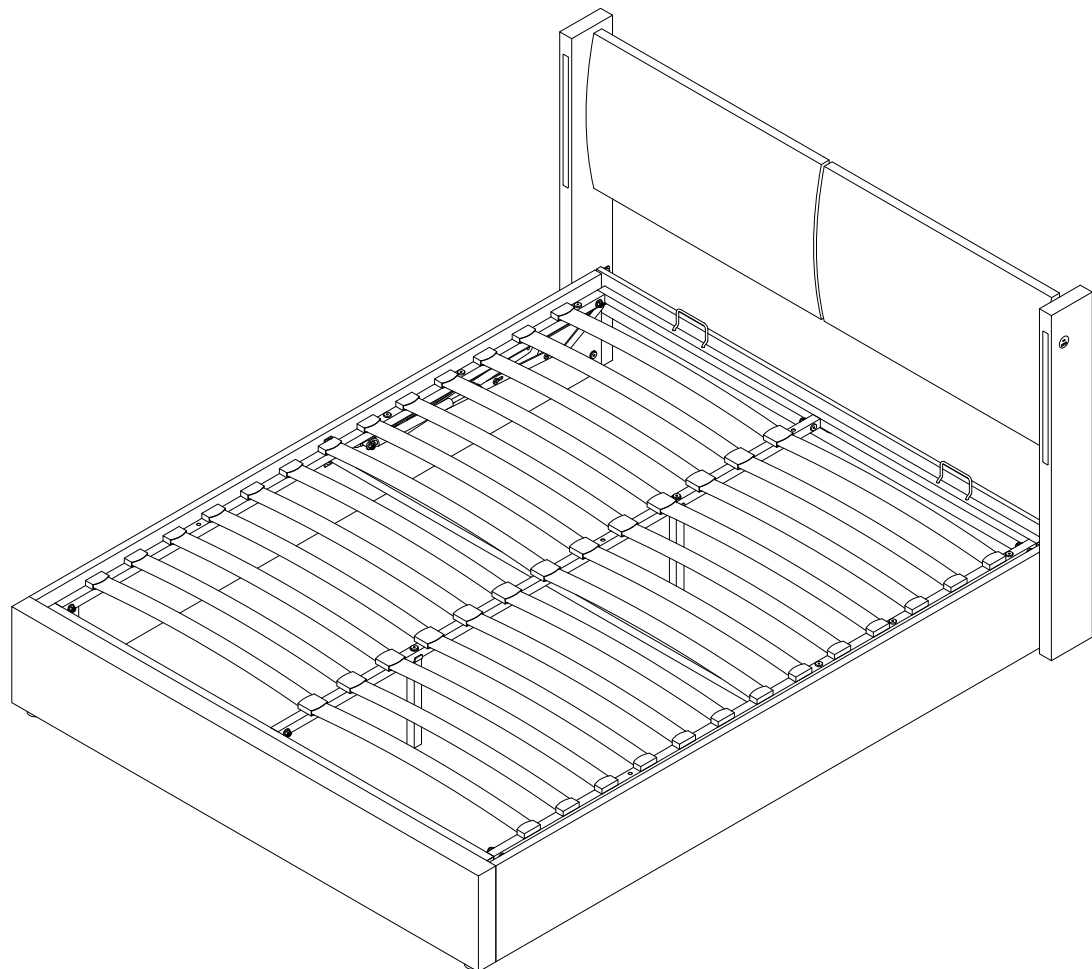

## TIPS



1. Please read the instructions fully before assembly. These instructions include important information which could ensure correct assembly. We have been working on providing high quality products for you. However, in the rare instance that your product is defective, missing parts or there are some issues, please don't hesitate to contact our customer service to submit parts requirements, assembly suggestion, or warranty claims, and we will give the best solution as soon as possible. If necessary, we need you to provide some more clear pictures of the issue.
2. Insert the screws in holes and tighten the screws, but not too tight, 70%~80% is ok, finally tighten all the screws. If some issues happened that some screws can not target to the hole or some parts are difficult to install, please adjust the tightness of the screws.
3. 2 people are recommended to finish.

## TIPPS

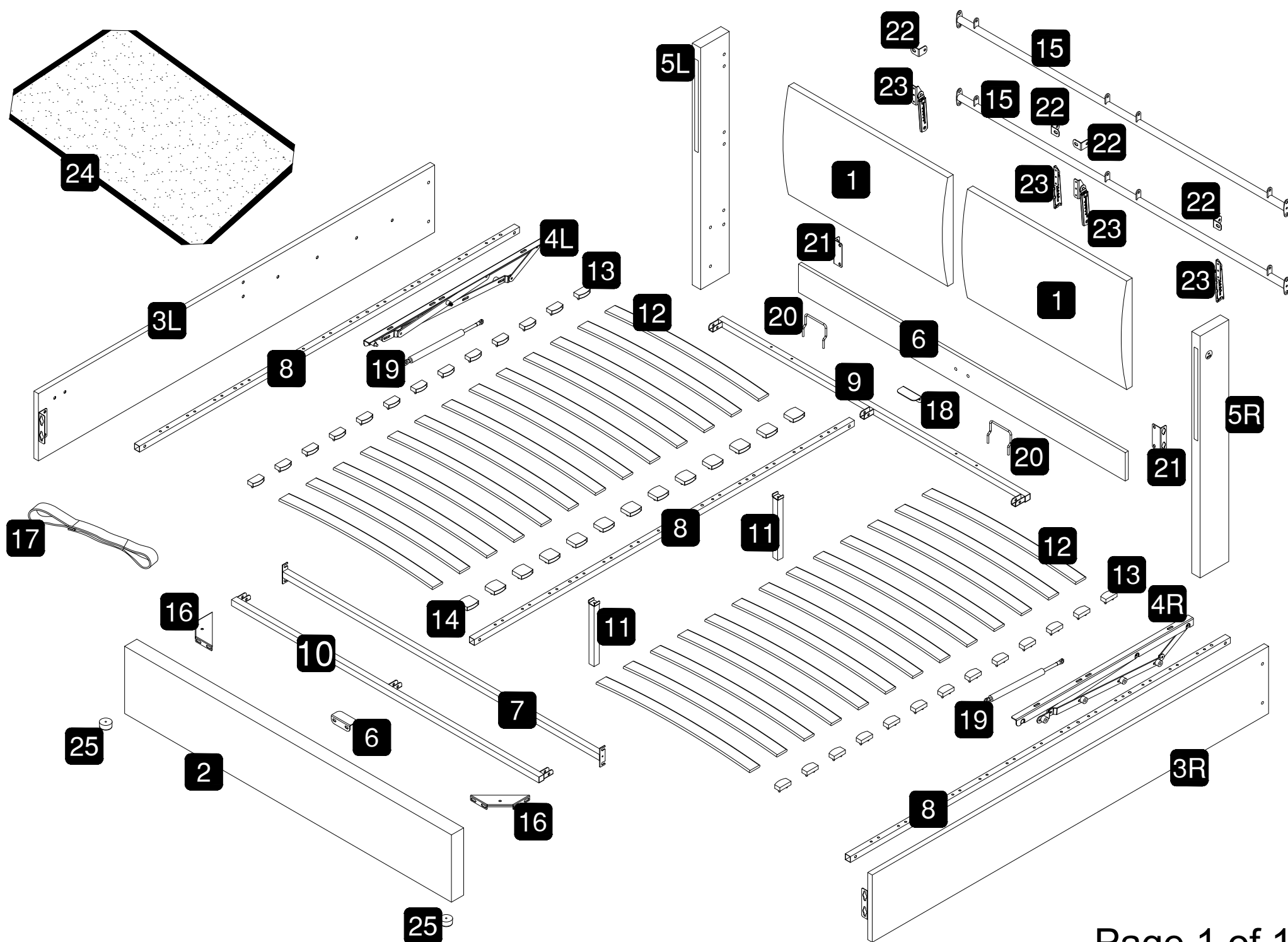
1. Bitte lesen Sie die Anweisungen vor der Montage sorgfältig durch. Diese Anweisungen enthalten wichtige Informationen, um eine korrekte Montage zu gewährleisten. Wir bemühen uns, Ihnen qualitativ hochwertige Produkte zu bieten. In seltenen Fällen, dass Ihr Produkt beschädigt ist, Teile fehlt oder Sie auf Probleme bei der Montage stoßen, wenden Sie sich damit bitte an unseren Kundendienst, wir werden Ihnen die beste Lösung so schnell wie möglich bieten. Um Ihr Problem schnell zu lösen, bitte stellen Sie uns einige Bilder zur Verfügung, die das Produktproblem deutlich widerspiegeln können. Vielen Dank !
2. Setzen Sie die Schrauben in die Löcher ein und ziehen Sie die Schrauben an, aber nicht zu fest, 70 % ~ 80 % ist genug, und ziehen Sie schließlich alle Schrauben an. Wenn einige Schrauben nicht mit den Löchern ausgerichtet sind oder die Montage einiger Teile schwierig ist, stellen Sie bitte den Straffheitsgrad der Schrauben um.
3. Es wird empfohlen, dass 2 Personen das Produkt installieren.



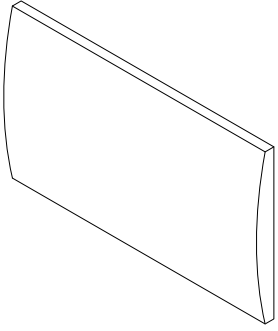
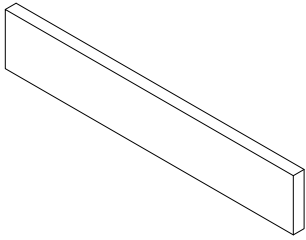
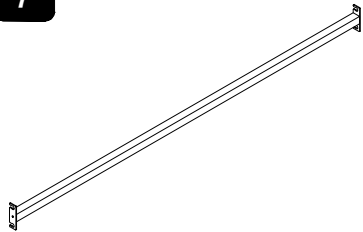
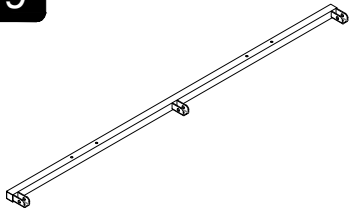
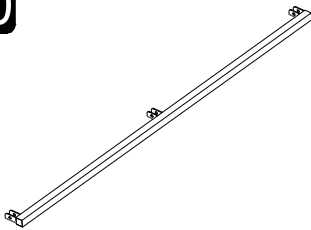

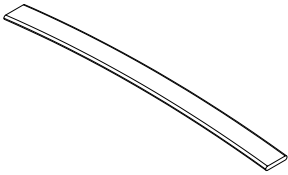
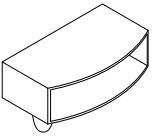
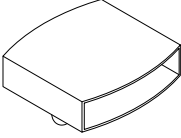
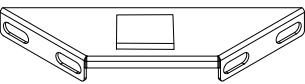
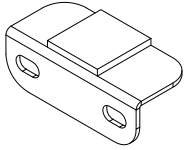
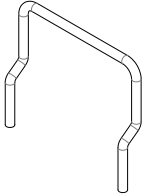
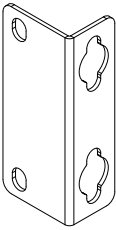
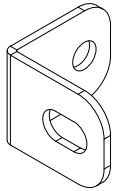
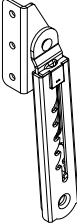
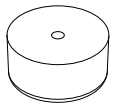
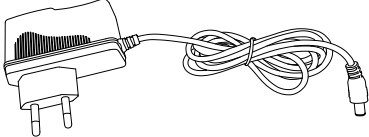
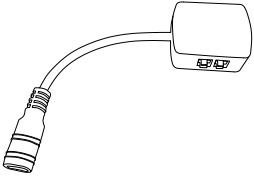
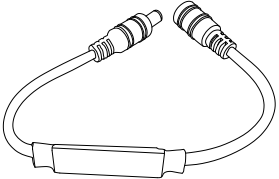
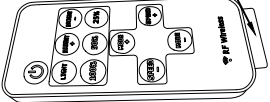
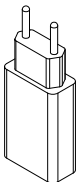
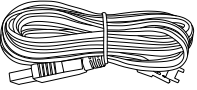
# Part List WF315868/WF315885/WF315887

<p><b>1</b></p>  <p>Headboard X2</p>	<p><b>2</b></p>  <p>Footboard X1</p>	<p><b>7</b></p>  <p>Reinforced Pipe X1</p>	<p><b>9</b></p>  <p>Cross Rail for Metal Slat Frame - Headend X1</p>	<p><b>10</b></p>  <p>Cross Rail for Metal Slat Frame - Footend X1</p>
<p><b>11</b></p>  <p>Centre Support Leg X2</p>	<p><b>12</b></p>  <p>Slats X26</p>	<p><b>13</b></p>  <p>Plastic Slat Caps X26</p>	<p><b>14</b></p>  <p>Centre Slat Caps X13</p>	<p><b>16</b></p>  <p>Metal Corner Bracket X2</p>
<p><b>18</b></p>  <p>Angle Iron X2</p>	<p><b>20</b></p>  <p>Mattress Stopper X2</p>	<p><b>21</b></p>  <p>Hook X2</p>	<p><b>22</b></p>  <p>Angle Iron X4</p>	<p><b>23</b></p>  <p>Bedside hinge X4</p>
<p><b>25</b></p>  <p>Leg X2</p>	<p><b>O</b></p>  <p>Power Transformer X1</p>	<p><b>P</b></p>  <p>Branching interface X1</p>	<p><b>Q</b></p>  <p>Controller X1</p>	<p><b>R</b></p>  <p>Unplug the battery separator of the remote control before use.</p> <p>Remote Control X1</p>
<p><b>S</b></p>  <p>Power Transformer X1</p>	<p><b>T</b></p>  <p>power line X1</p>			

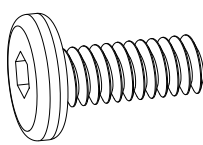
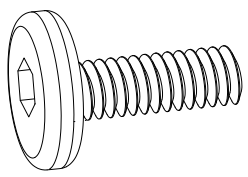
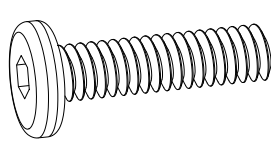
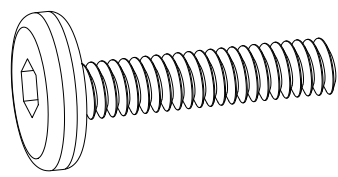
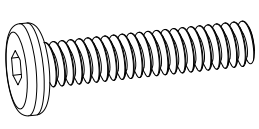
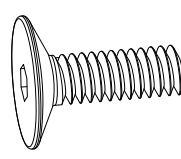
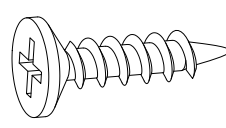
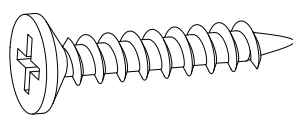
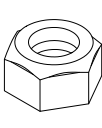
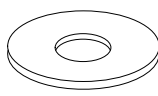
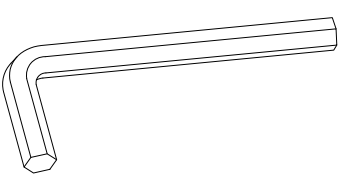
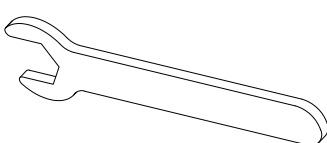
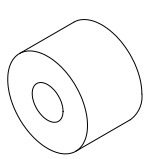
# Hardware List WF315868/WF315885/WF315887

<p><b>A</b></p>  <p>Bolts(M8x16mm) X8</p>	<p><b>B</b></p>  <p>Bolts(M8x20mm) X36</p>	<p><b>C</b></p>  <p>Bolts(M8x30mm) X8</p>	<p><b>D</b></p>  <p>Bolts(M8x40mm) X16</p>	<p><b>E</b></p>  <p>Bolts(M6x35mm) X2</p>
<p><b>F</b></p>  <p>Bolts(M8x25mm) X4</p>	<p><b>G</b></p>  <p>Screw(4.0x25mm) X12</p>	<p><b>H</b></p>  <p>Screw(4.0x40mm) X2</p>	<p><b>J</b></p>  <p>Non-slip nuts(M8) X24</p>	<p><b>K</b></p>  <p>Flat Washer X20</p>
<p><b>L</b></p>  <p>Allen Key X1</p>	<p><b>M</b></p>  <p>Spanner X1</p>	<p><b>N</b></p>  <p>Plastic washer X8</p>		

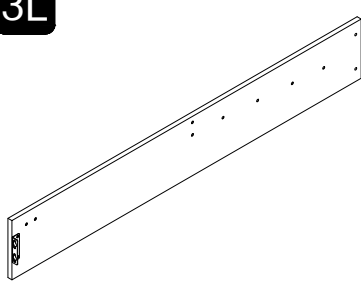
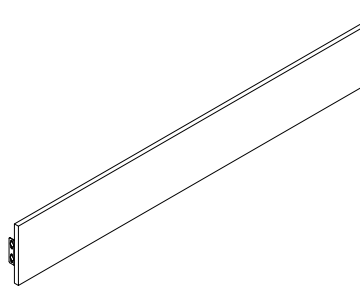
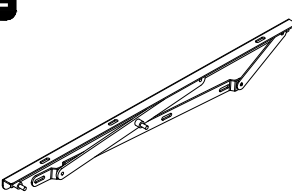
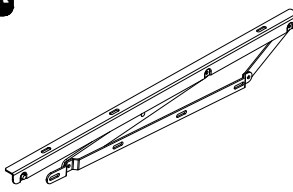

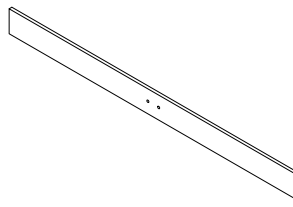
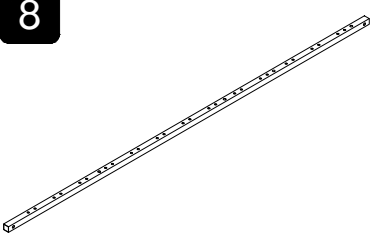
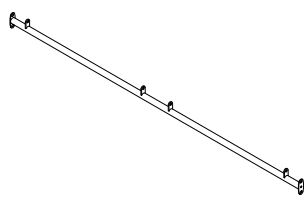
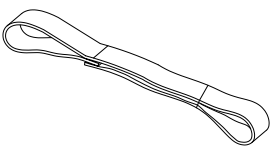
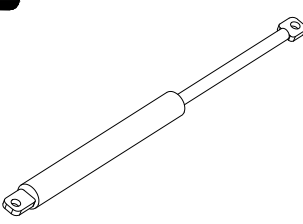
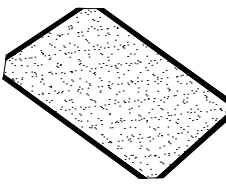
# Part List WF3158884/WF315886/WF315888

<p><b>3L</b></p>  <p>Side Rails(LH) X1</p>	<p><b>4L</b></p>  <p>Side Rails(RH) X1</p>	<p><b>4R</b></p>  <p>Lift Mechanism (LH) X1</p>	<p><b>4R</b></p>  <p>Lift Mechanism (RH) X1</p>	<p><b>5L</b></p>  <p>Head board leg (LH) X1</p>
<p><b>5R</b></p>  <p>Head board leg (RH) X1</p>	<p><b>6</b></p>  <p>Head board leg Connecting plate X1</p>	<p><b>8</b></p>  <p>Side Rails for Metal Slat Frame X3</p>	<p><b>15</b></p>  <p>Bedhead connection pipe X2</p>	<p><b>17</b></p>  <p>Rope X1</p>
<p><b>19</b></p>  <p>Gas Strut X2</p>	<p><b>24</b></p>  <p>Fabric Base X1</p>			

Attention: Do not tighten the screws before completing the entire installation. If you have any difficulty with the installation process, please feel free to contact us.

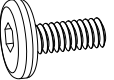
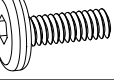

Achtung: Ziehen Sie die Schrauben nicht fest, bevor Sie die gesamte Installation abschließen. Wenn Sie Schwierigkeiten mit dem Installationsprozess haben, zögern Sie nicht, uns zu kontaktieren.

### Step 1:

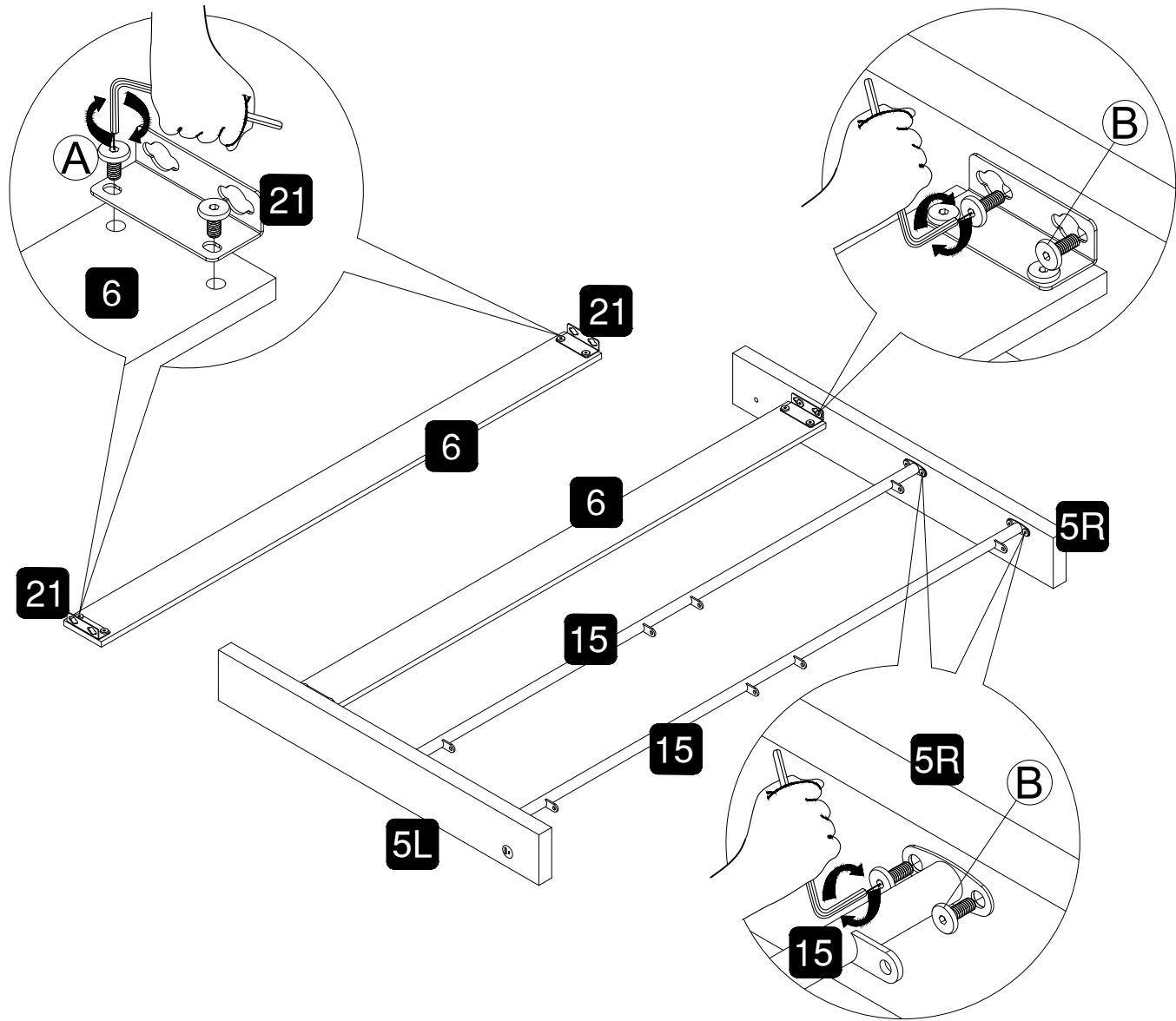
- A**  x4
- B**  x12
- L**  x1

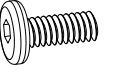
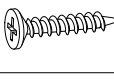

### Step 2:

- A**  x4
- H**  x2
- L**  x1

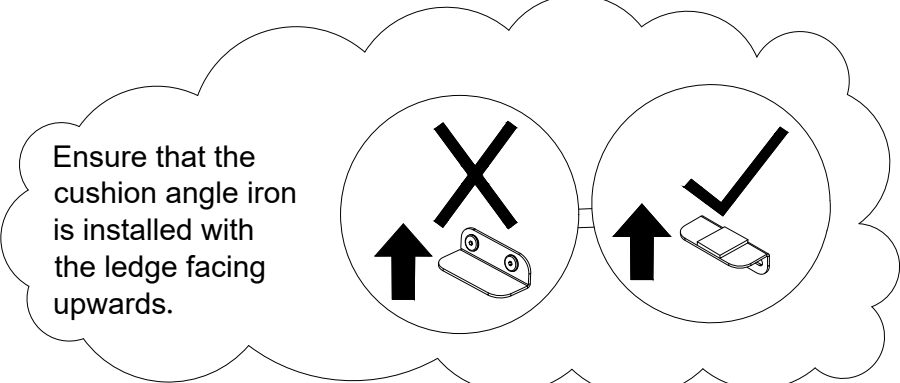
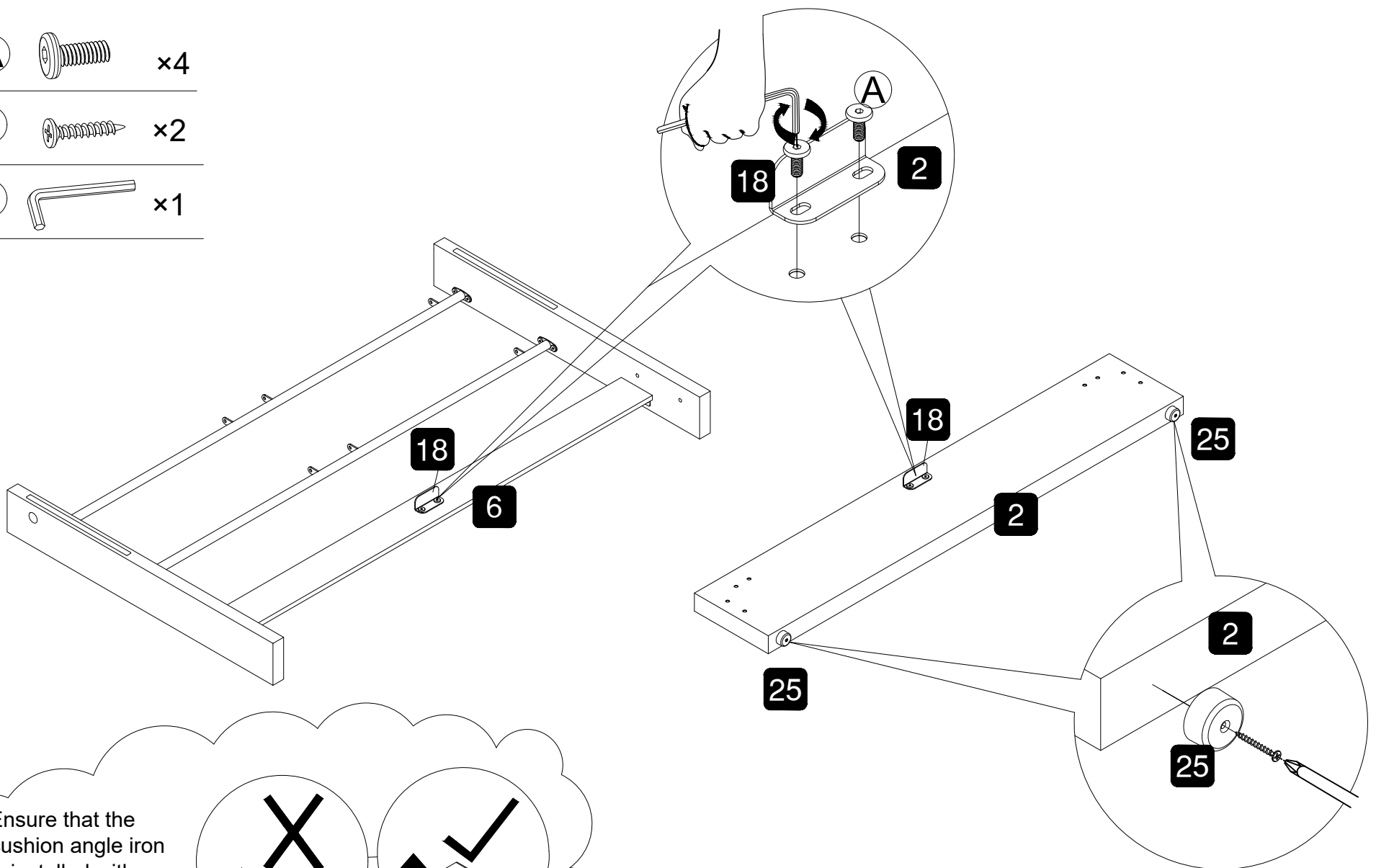

### Step 3:

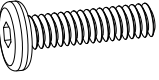
**C**  x8

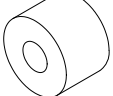
**O**  x8

**L**  x1

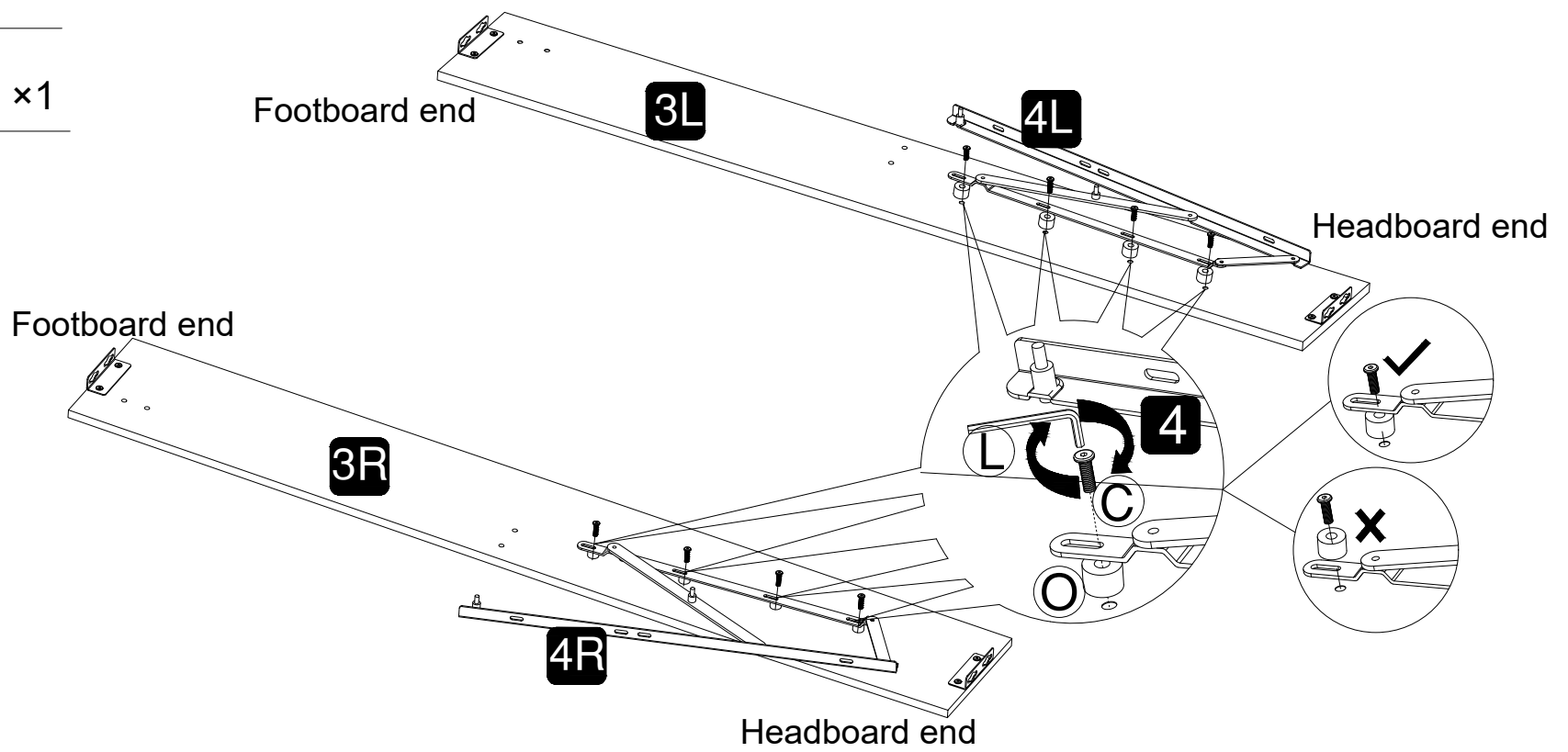

### Step 4:

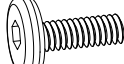
**B**  x4

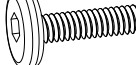
**D**  x4

**K**  x4

**L**  x1

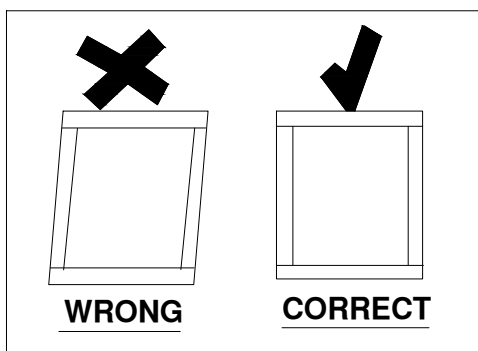
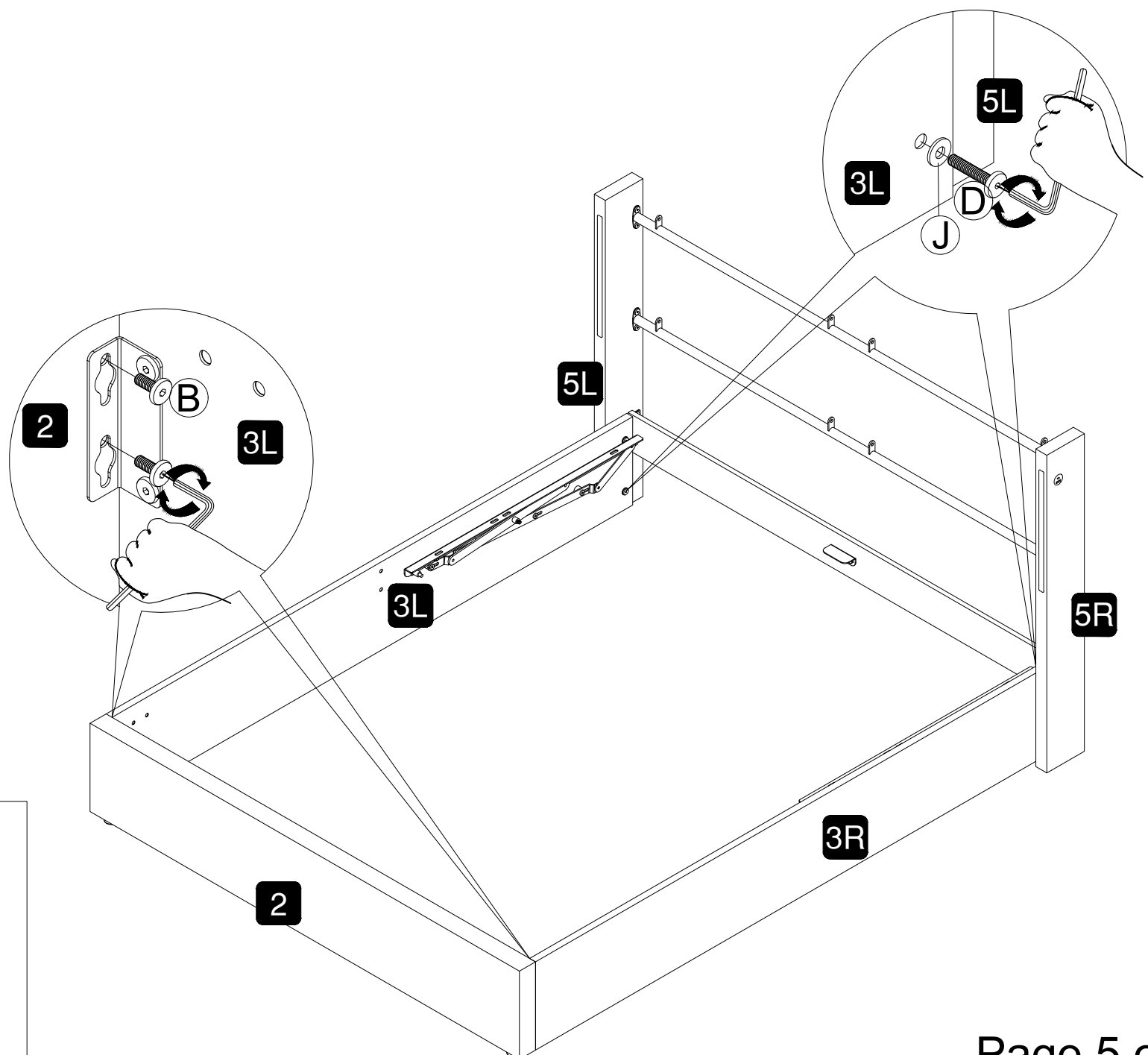

## Step 5:

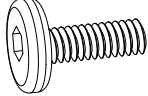
**B**  x8

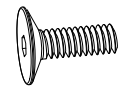
**F**  x4

**L**  x1

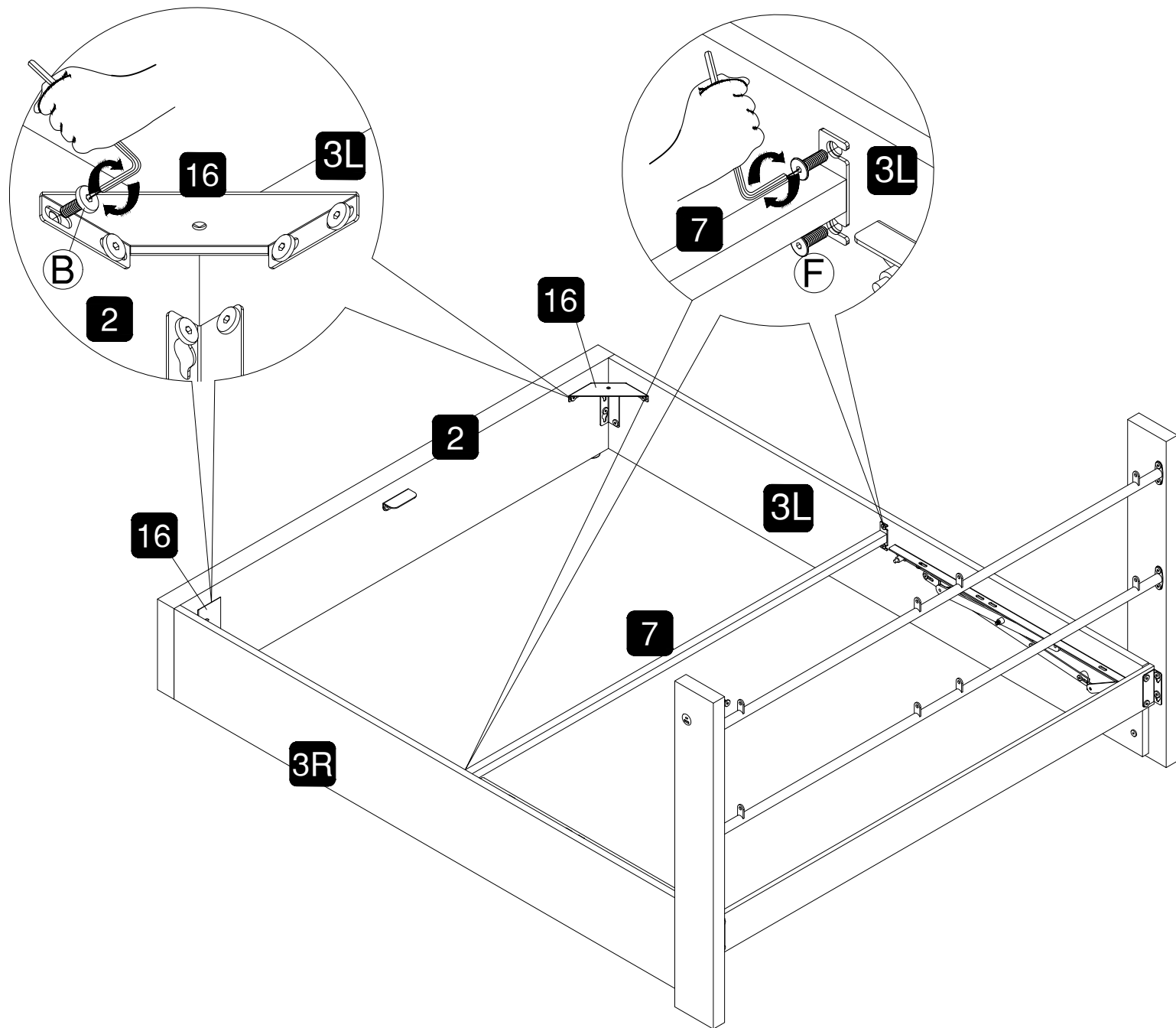

## Step 6:

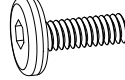
**B**  x8

**J**  x4

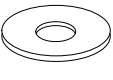
**K**  x4

**L**  x1

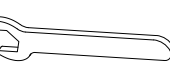
**M**  x1

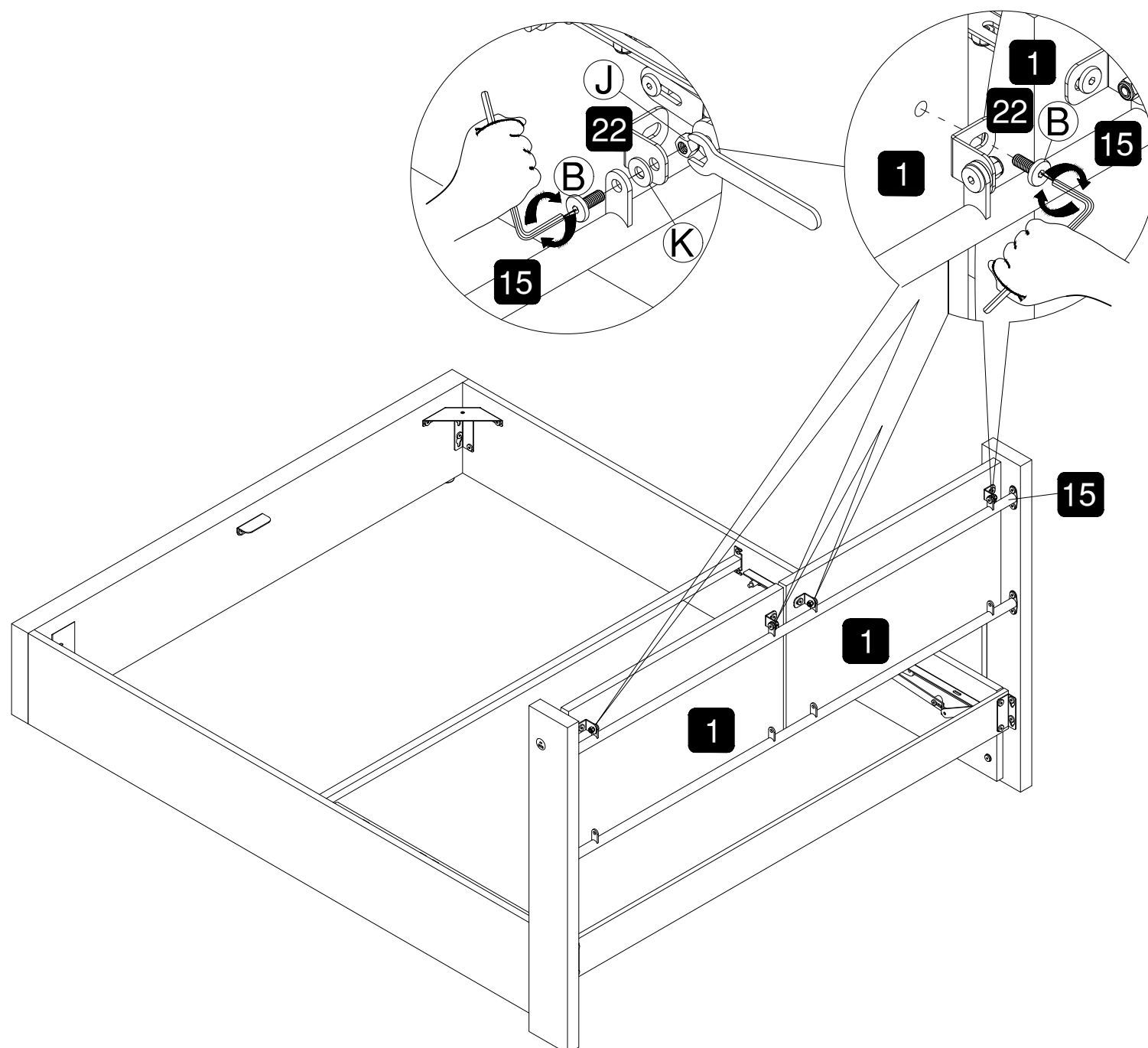

## Step 7:

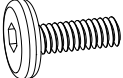
- B**  x4

---

- J**  x4

---

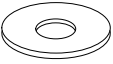
- K**  x4

---

- G**  x12

---

- L**  x1

---

- M**  x1

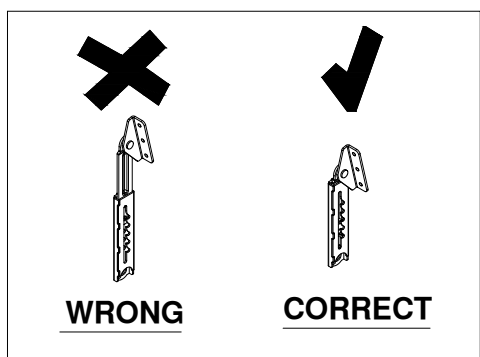
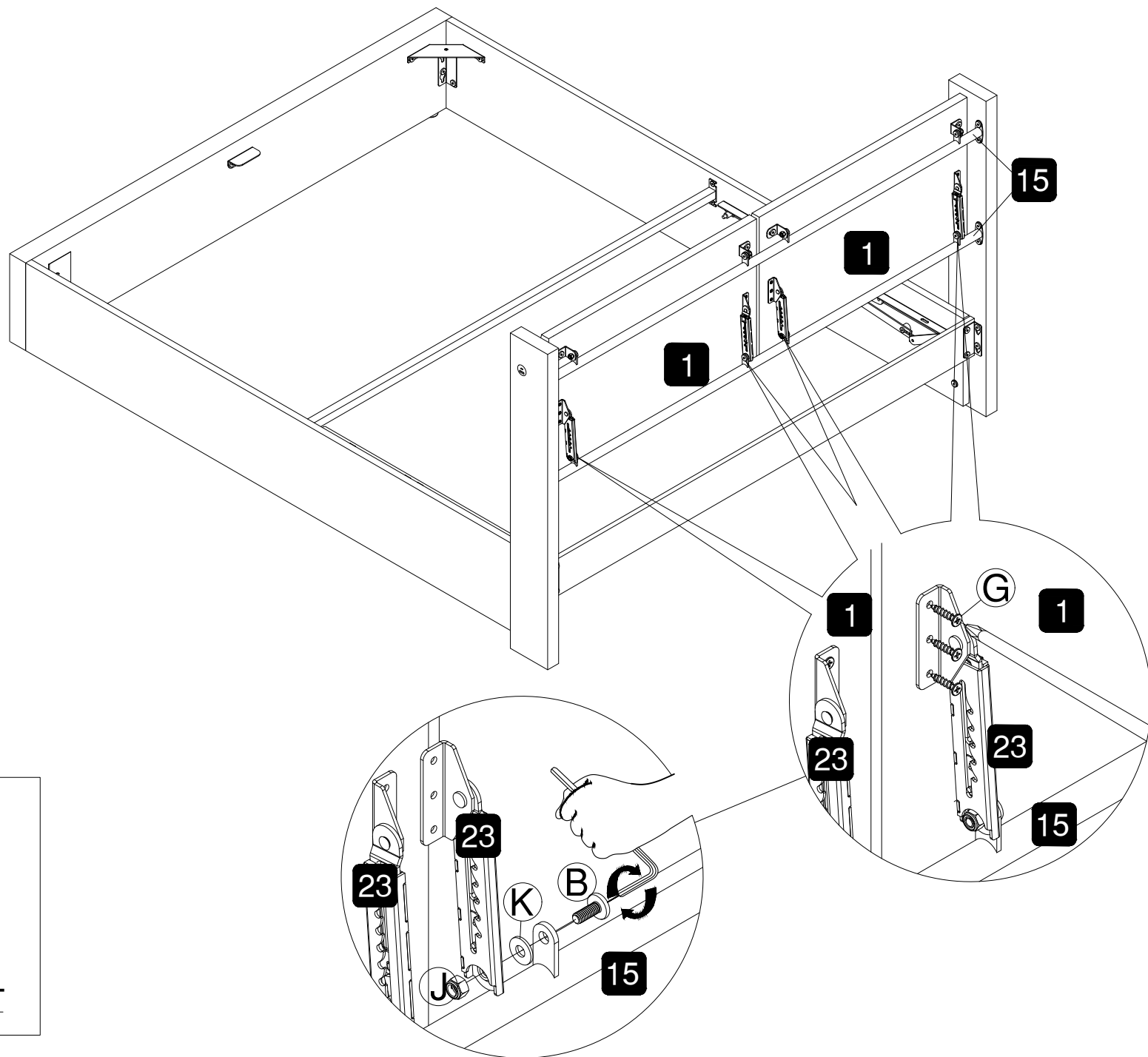

## Step 8:

- D**  x6

---

- J**  x6

---

- K**  x6

---





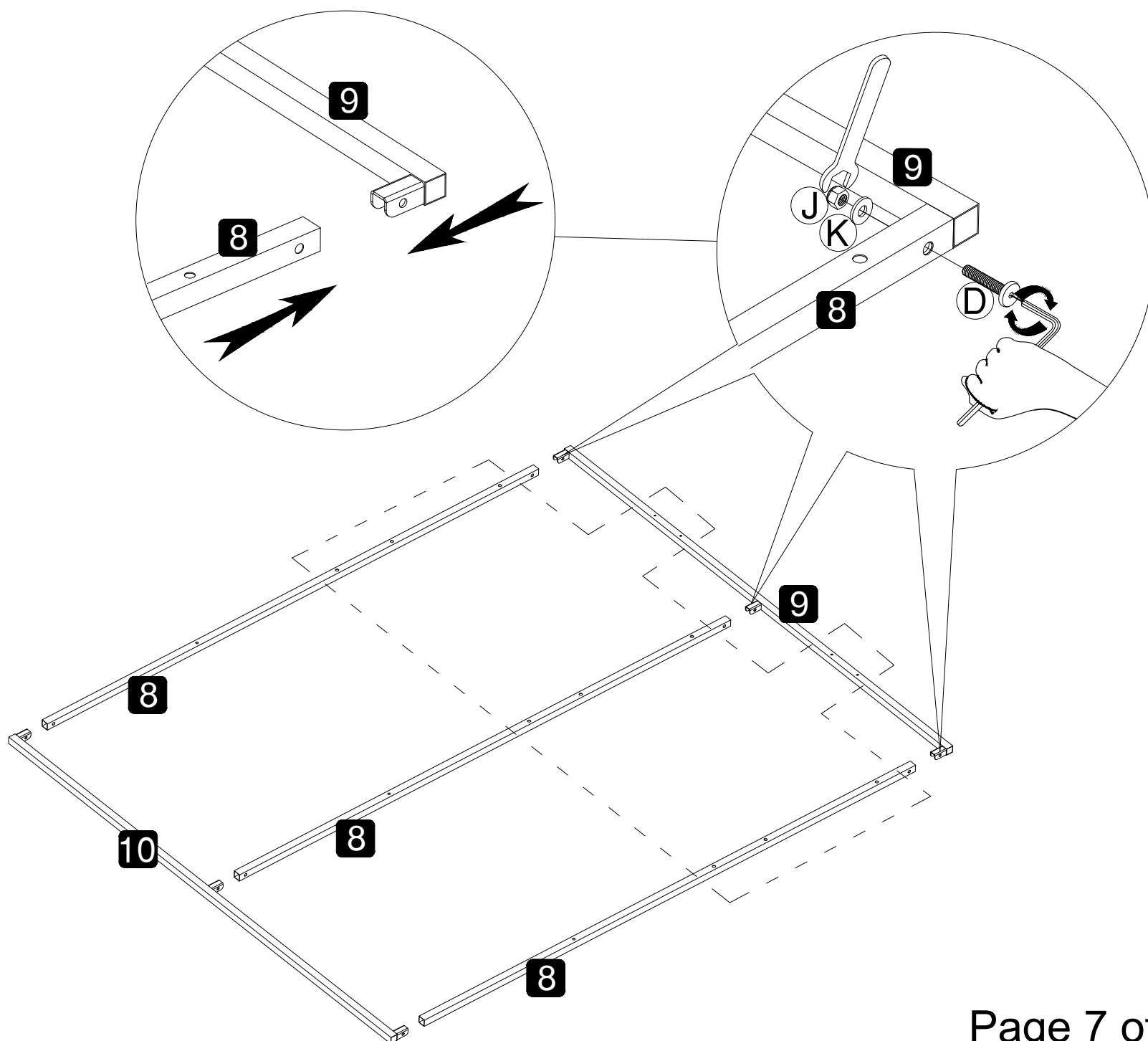

- L**  x1

---

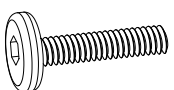
- M**  x1



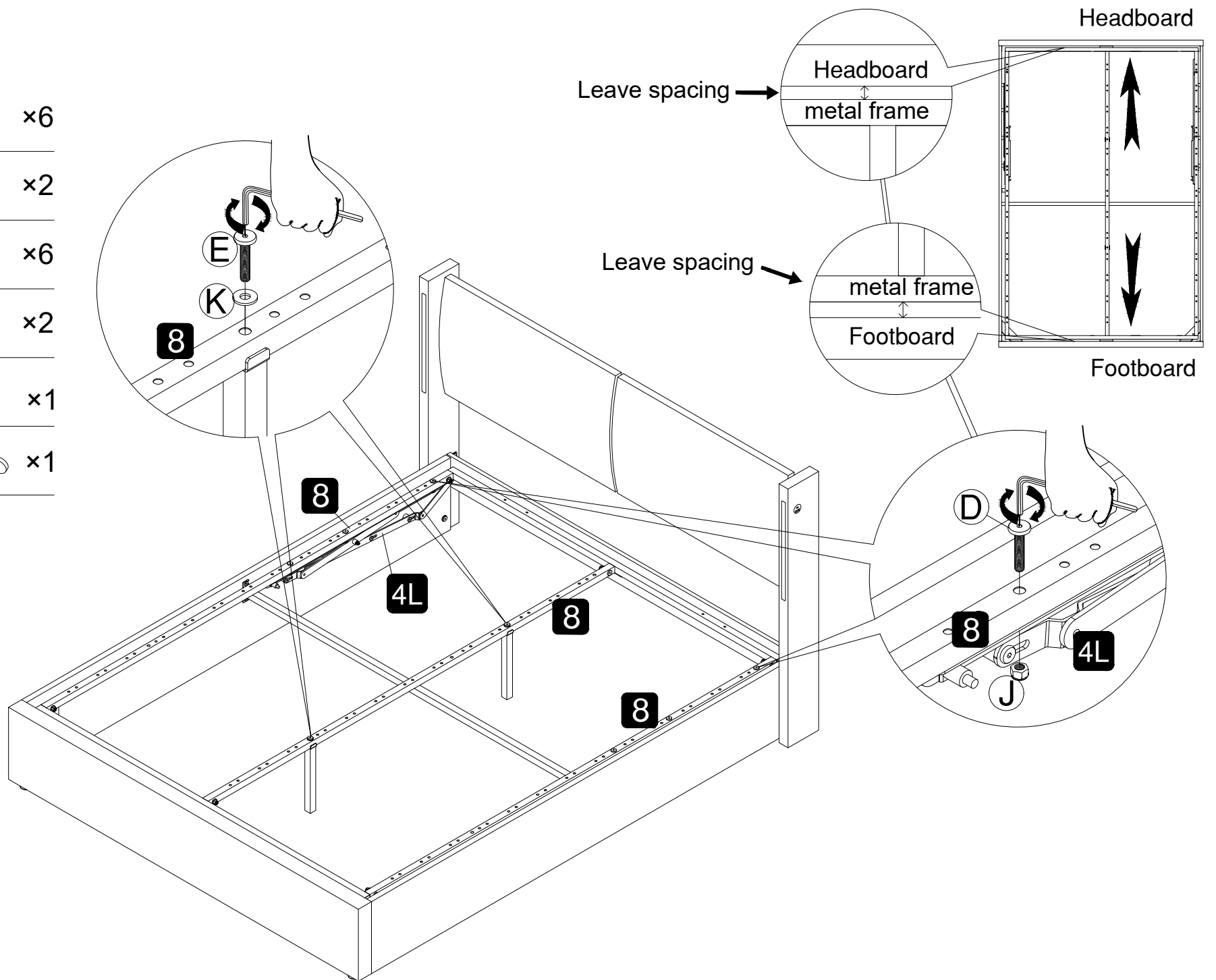

# Step 9:

- D  ×6
- E  ×2
- J  ×6
- K  ×2
- L  ×1
- M  ×1



# Step 10:

- 13  ×26
- 14  ×13

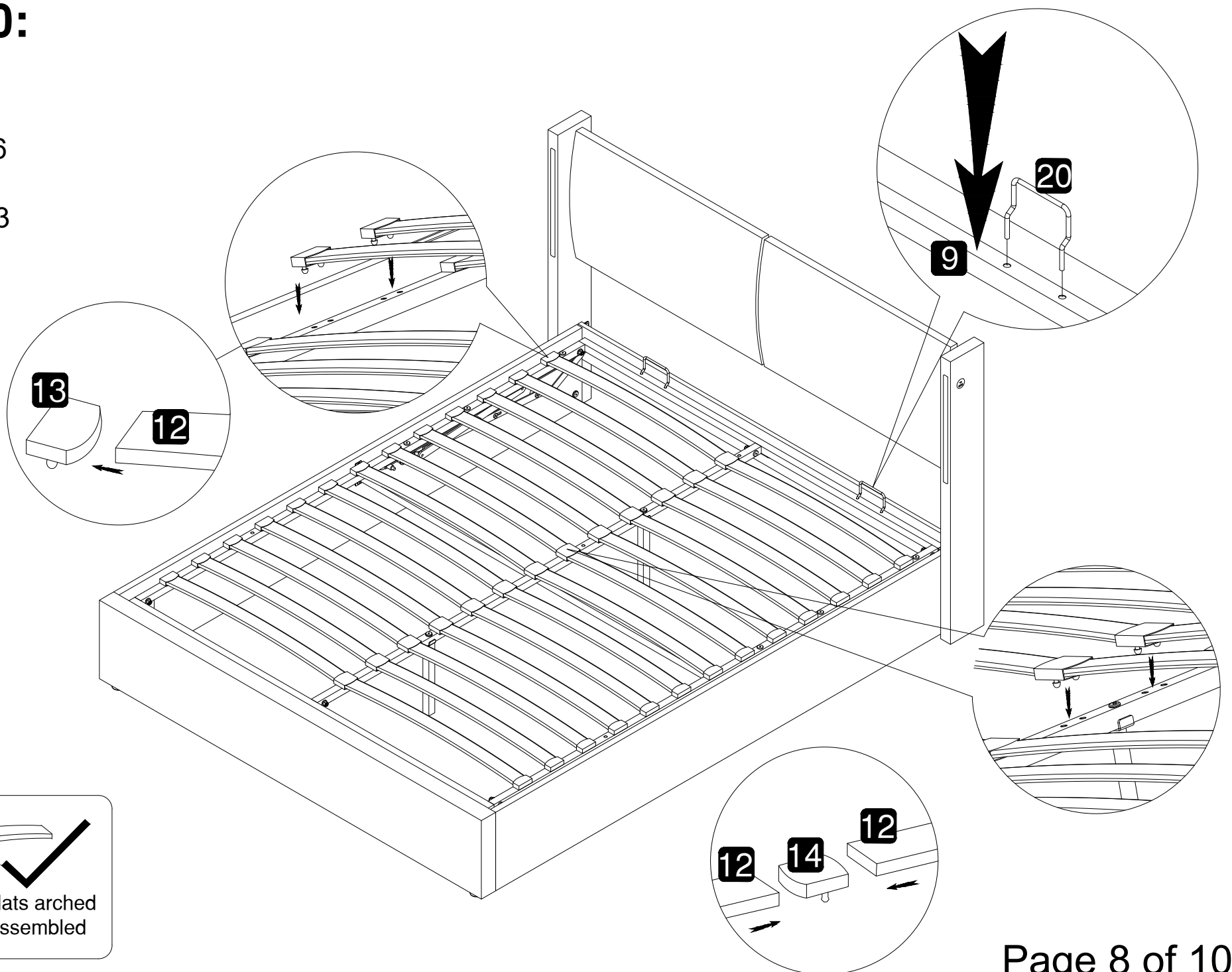

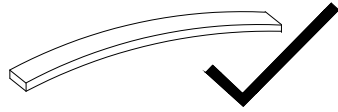
  
 Make sure all slats arched like this when assembled



## Step 11:

**J**  x4

**M**  x1

**17**  x1

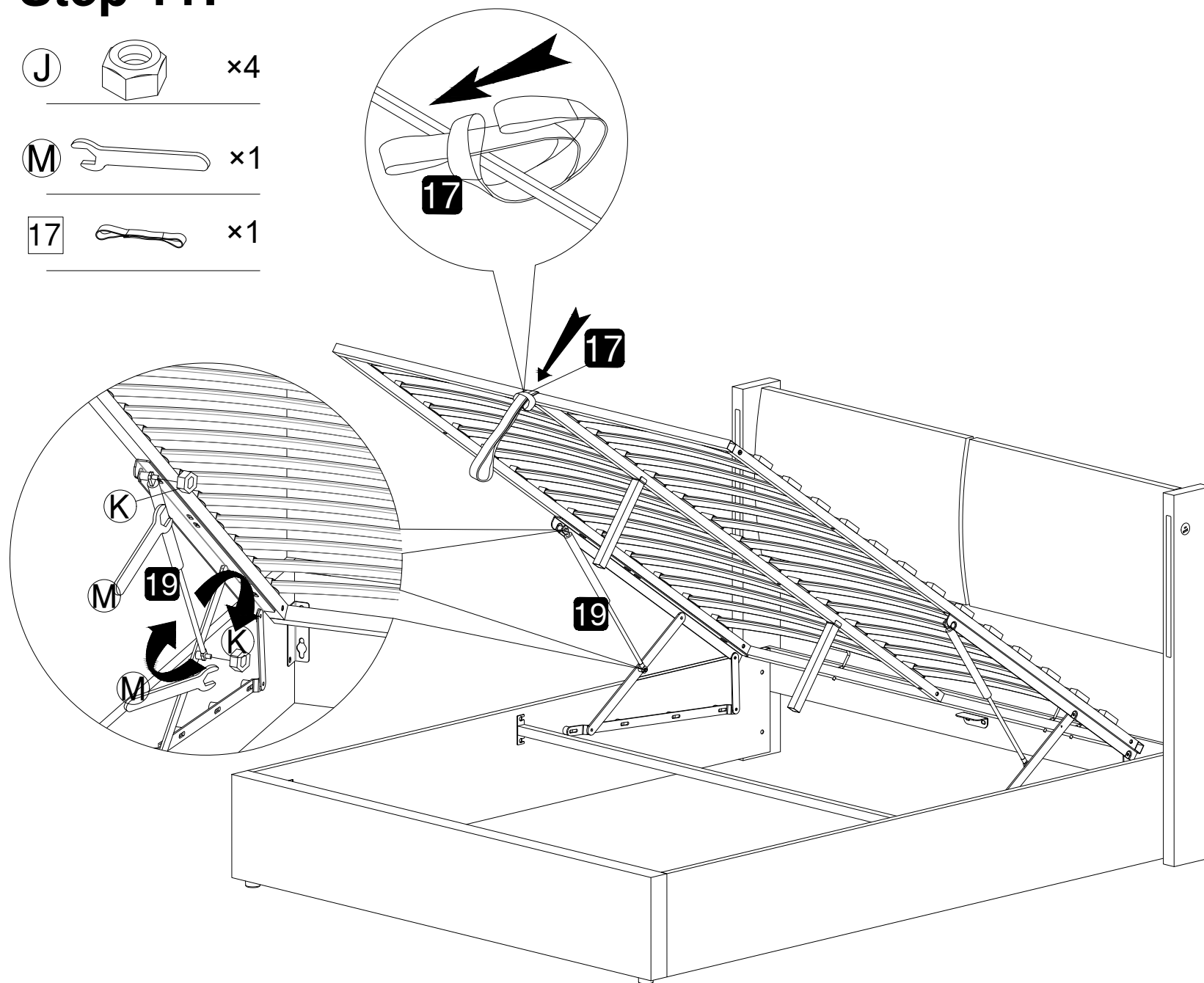

## Step 12:

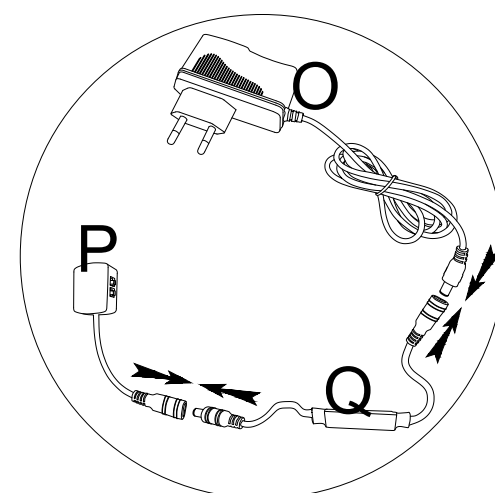
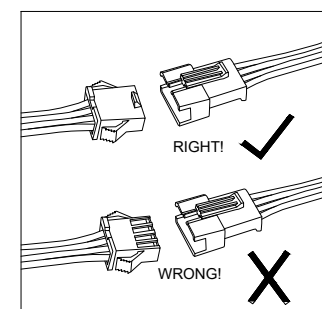
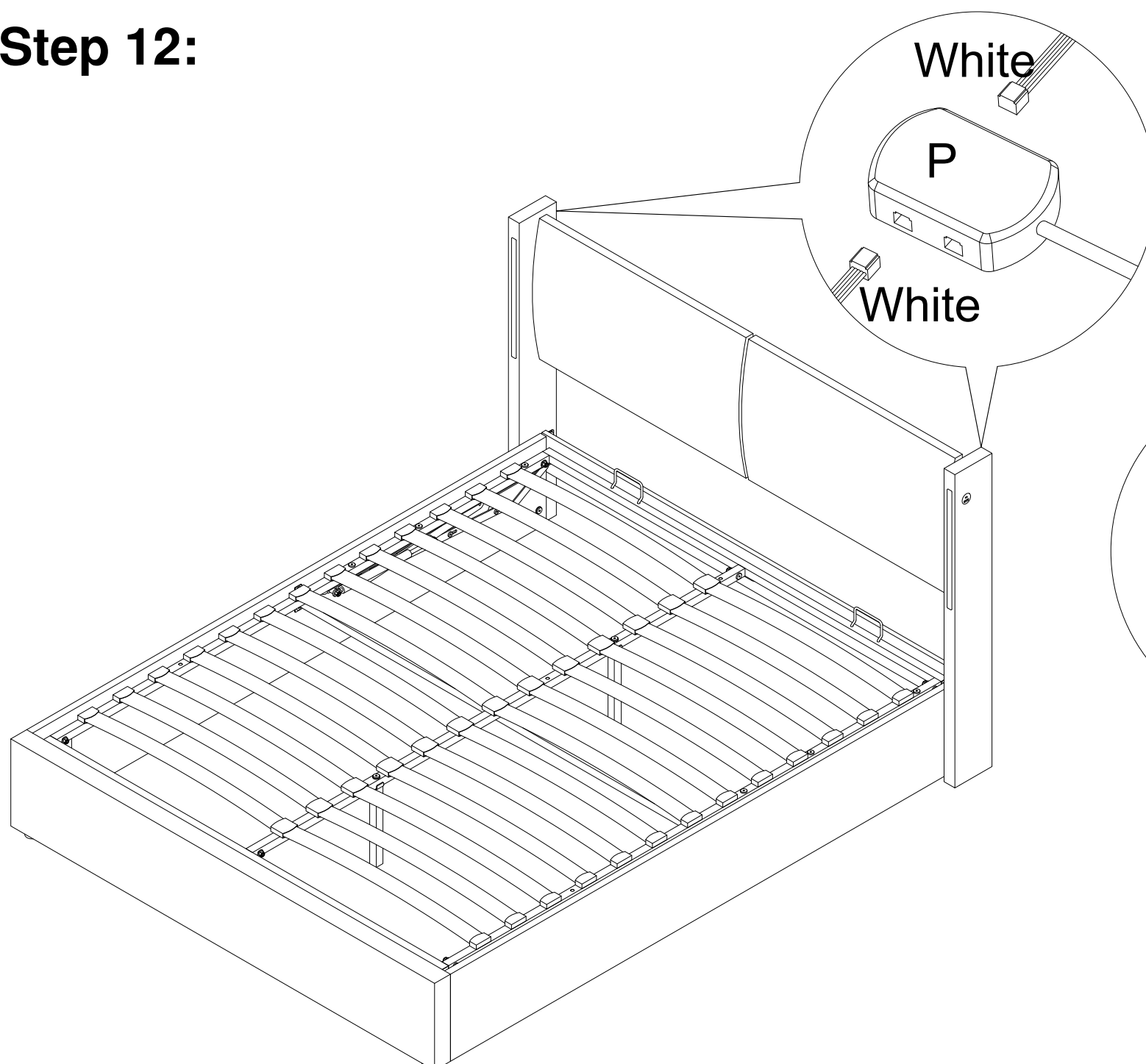

# Step 11:

