

- |   |   |
|---|---|
| (D) <b>Montageanleitung</b><br>1370             | (GB) <b>Assembly instructions</b><br>1370   |
| (FR) <b>Notice de montage</b><br>1370           | (IT) <b>Istruzioni di montaggio</b><br>1370 |
| (NL) <b>Handleiding voor de montage</b><br>1370 | (PL) <b>Instrukcja montażu</b><br>1370      |
| (CZ) <b>Montážní návod</b><br>1370              | (SK) <b>Návod na montáž</b><br>1370         |
| (HU) <b>Szerelési útmutató</b><br>1370          | (RO) <b>Instrukțiuni de montaj</b><br>1370  |
| (TR) <b>Montaj talimatı</b><br>1370             | (RU) <b>Инструкция по монтажу</b><br>1370   |

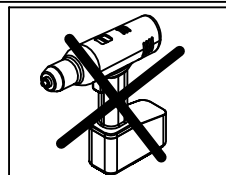
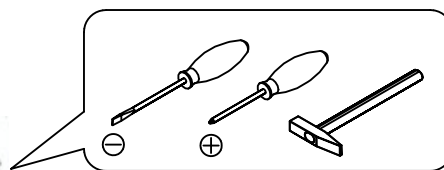
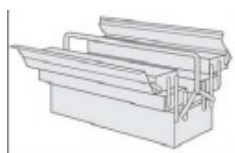
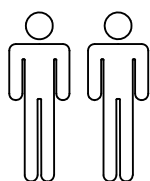

Service • Dienstverlening • Serwis • Servis • Сервисная служба • Assistenza • Szerviz

Name • Nom • Nome • Naam • Nazwa • Jméno •  
Názov • Név • Denumire • İsim • Название

Nr. • No. • № • Номер • Č • Sz

Typ • Type • Тип • Típus • Tun

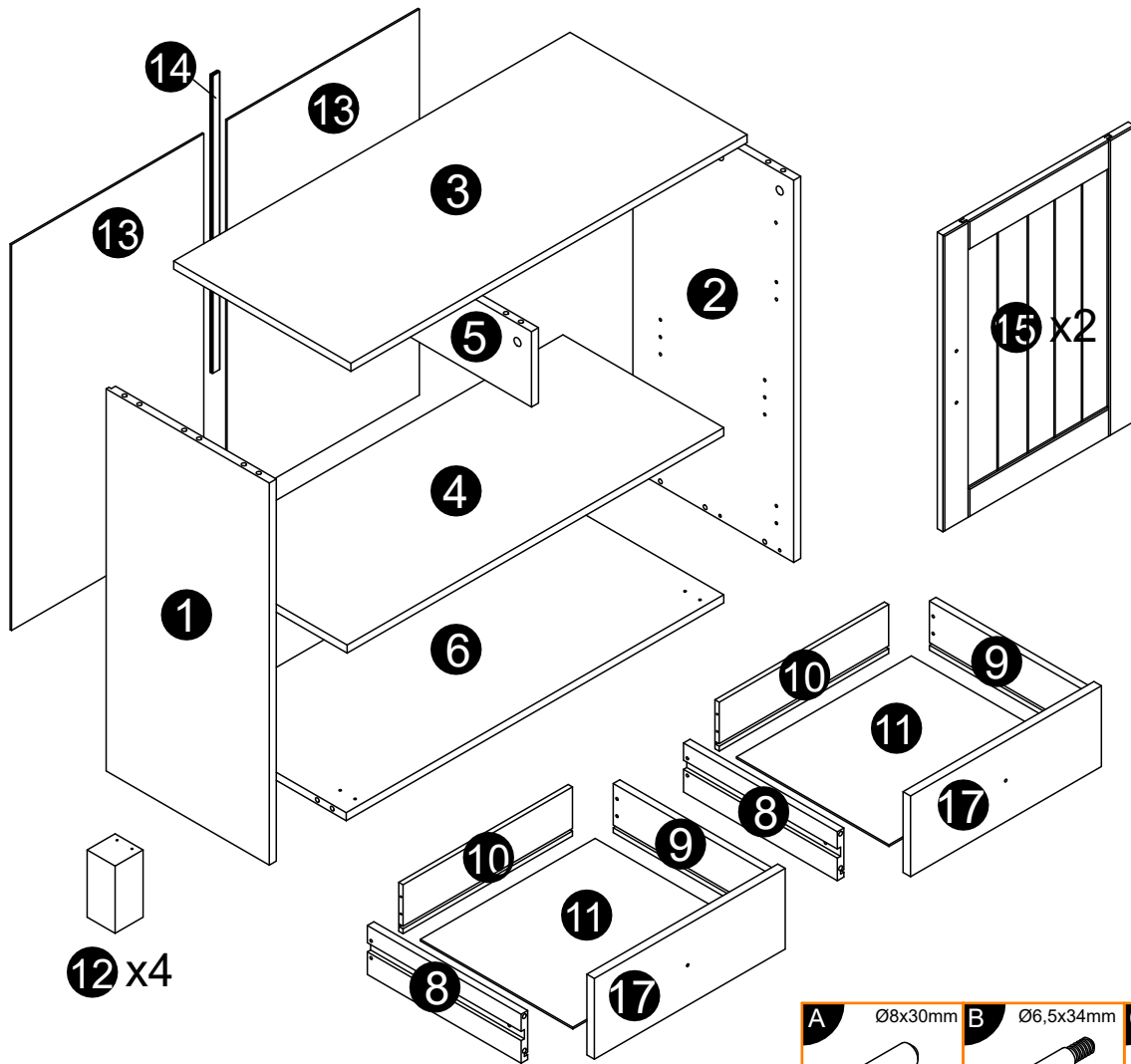
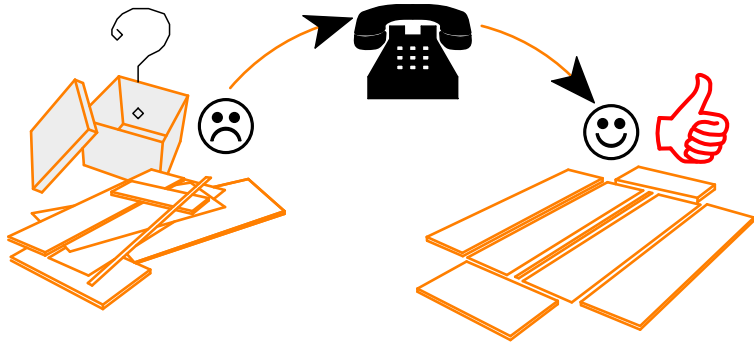
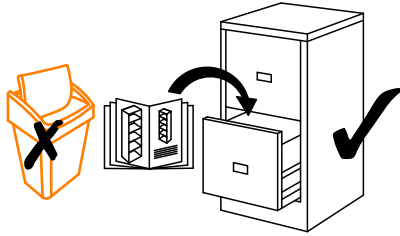

<b>D</b> Ø3,5x15mm 9x	<b>E</b> 4x	<b>G</b> Ø1,2x20mm 50x	<b>H</b> 1x	<b>I</b> 20x16mm Ø4,5mm 1x	<b>J</b> Ø4x60mm 1x	<b>K</b> Ø5x16mm 4x	<b>L</b> 4x	<b>M</b> Ø4x20mm 4x
<b>N</b> Ø26x3mm 4x	<b>O</b> Ø3,5x35mm 16x	<b>U</b> 1x	<b>Aa</b> Ø5,8x9mm 8x	<b>Ac</b> M4x10mm 4x	<b>Ad</b> 310mm 4x	<b>Ae</b> Ø26mm 4x		

<b>A</b> Ø8x30mm 23x	<b>B</b> Ø6,5x34mm 15x	<b>C</b> Ø15x11mm 15x
-------------------------	---------------------------	--------------------------

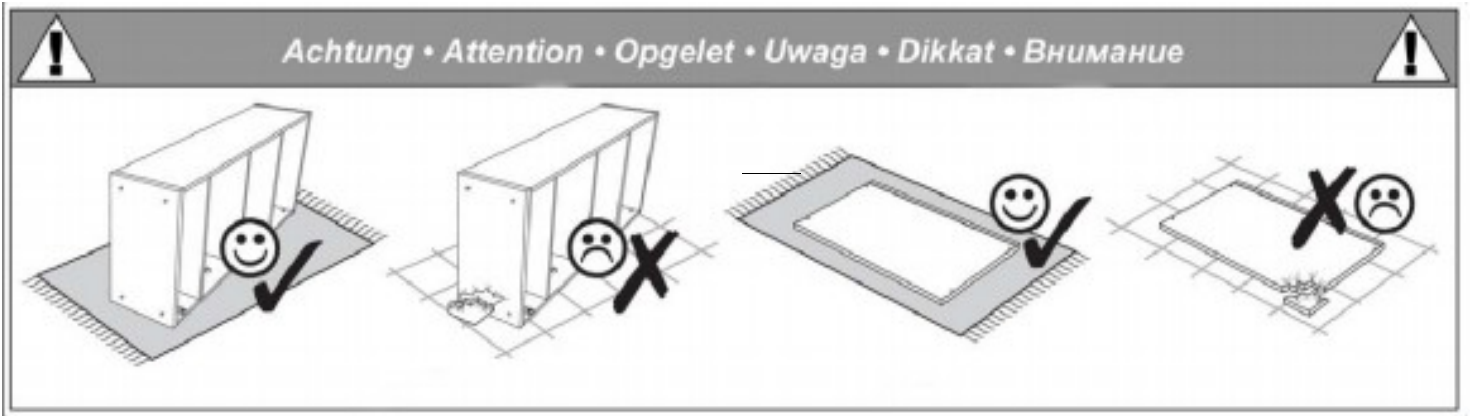

1

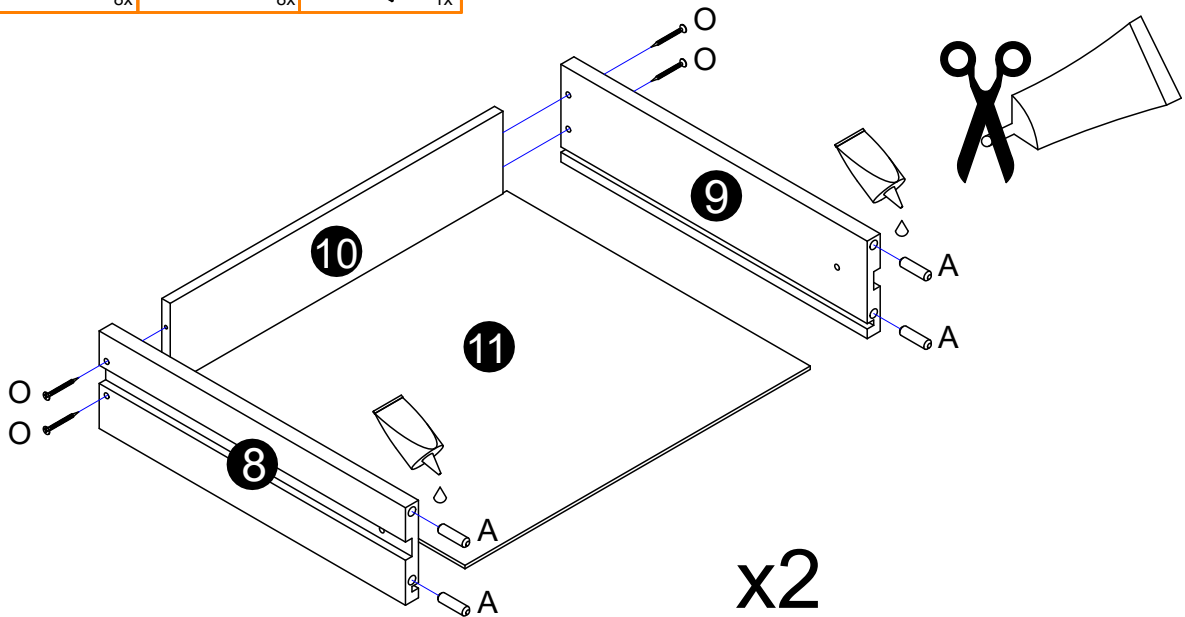
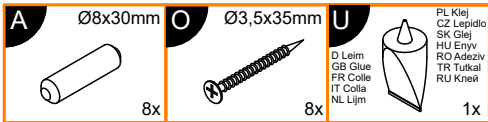

2

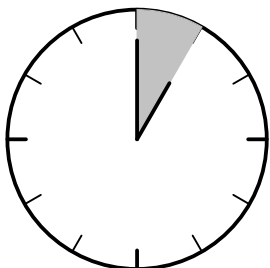
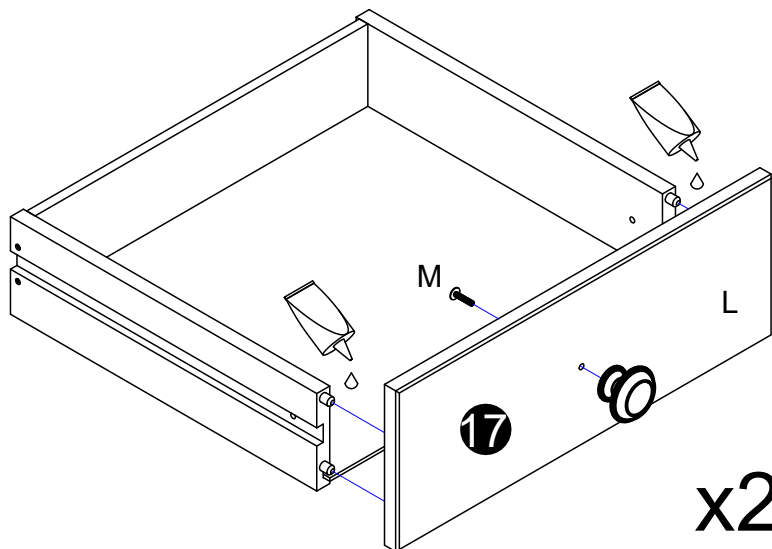
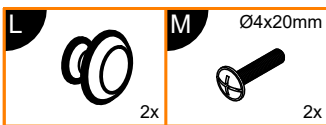

3

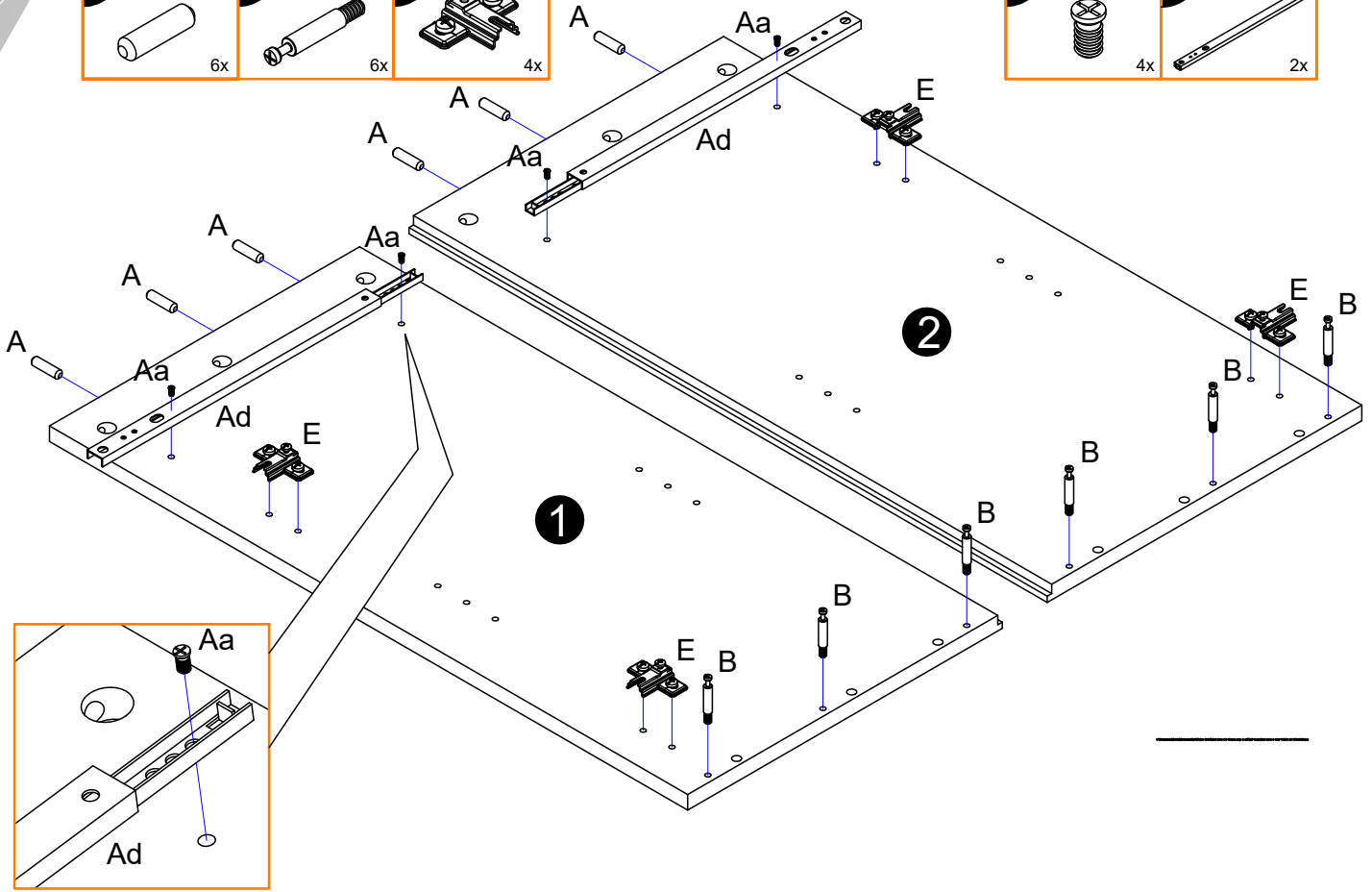
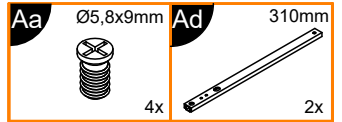
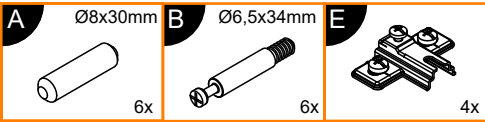

4

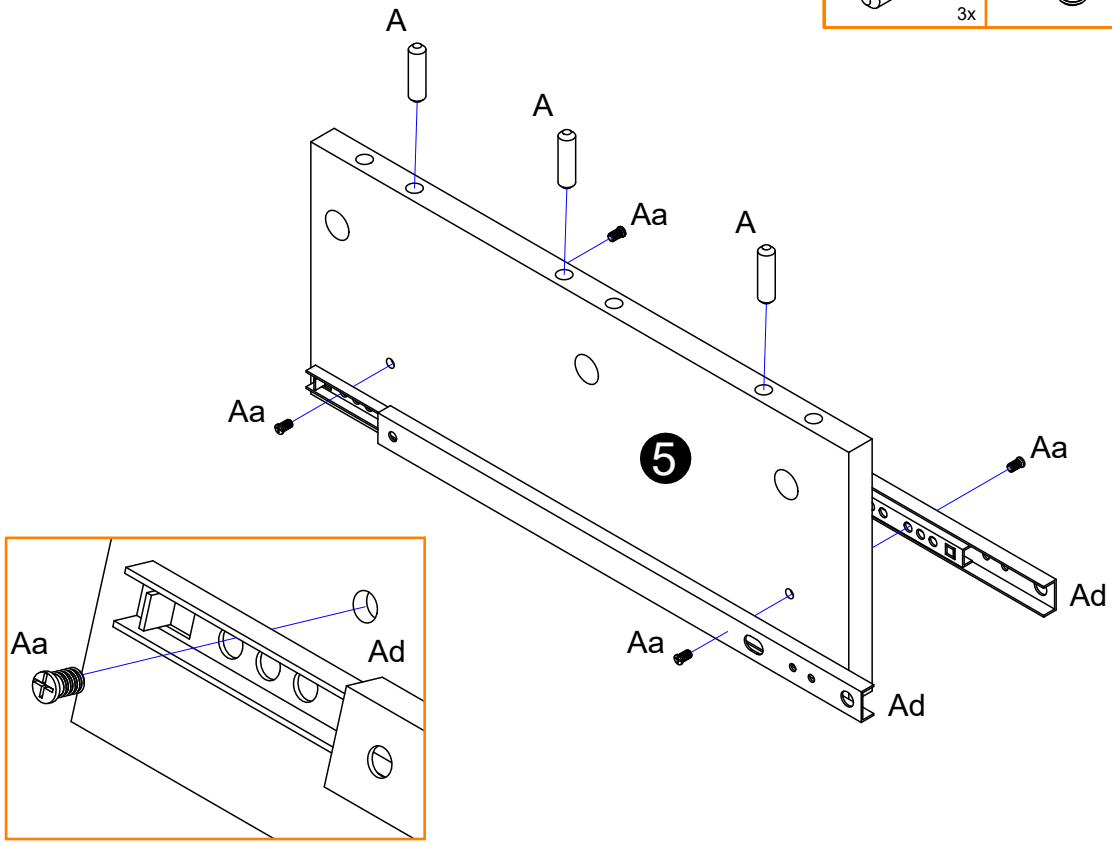
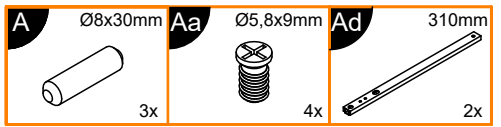

5

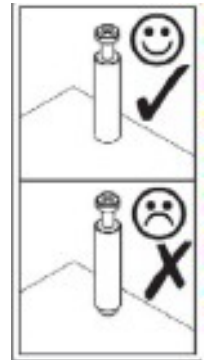
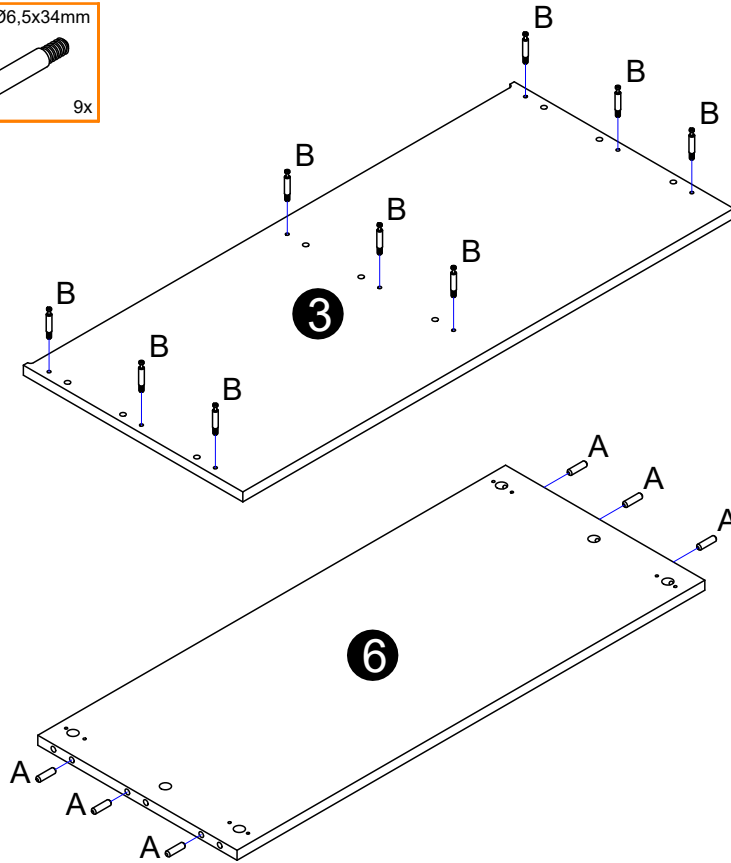
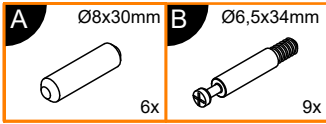

6

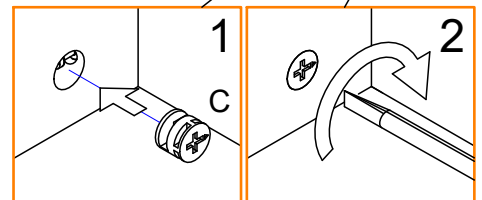
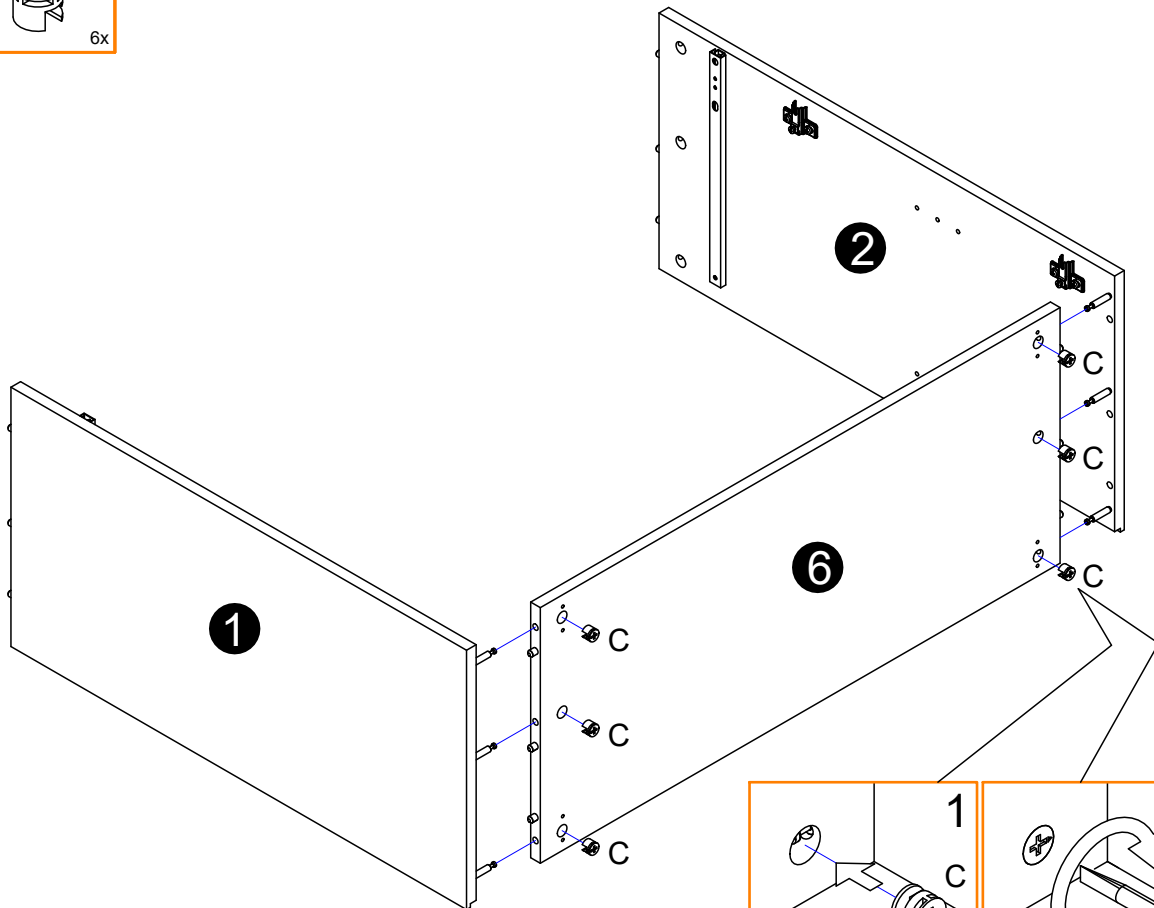
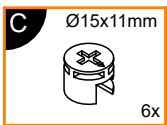

7

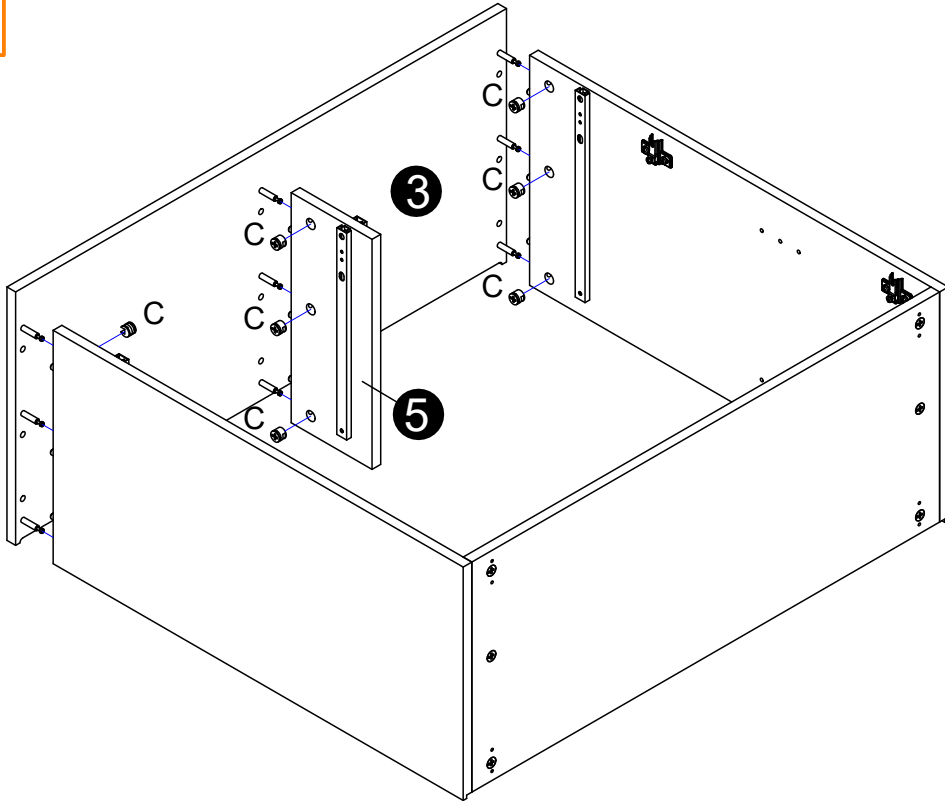
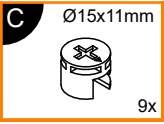

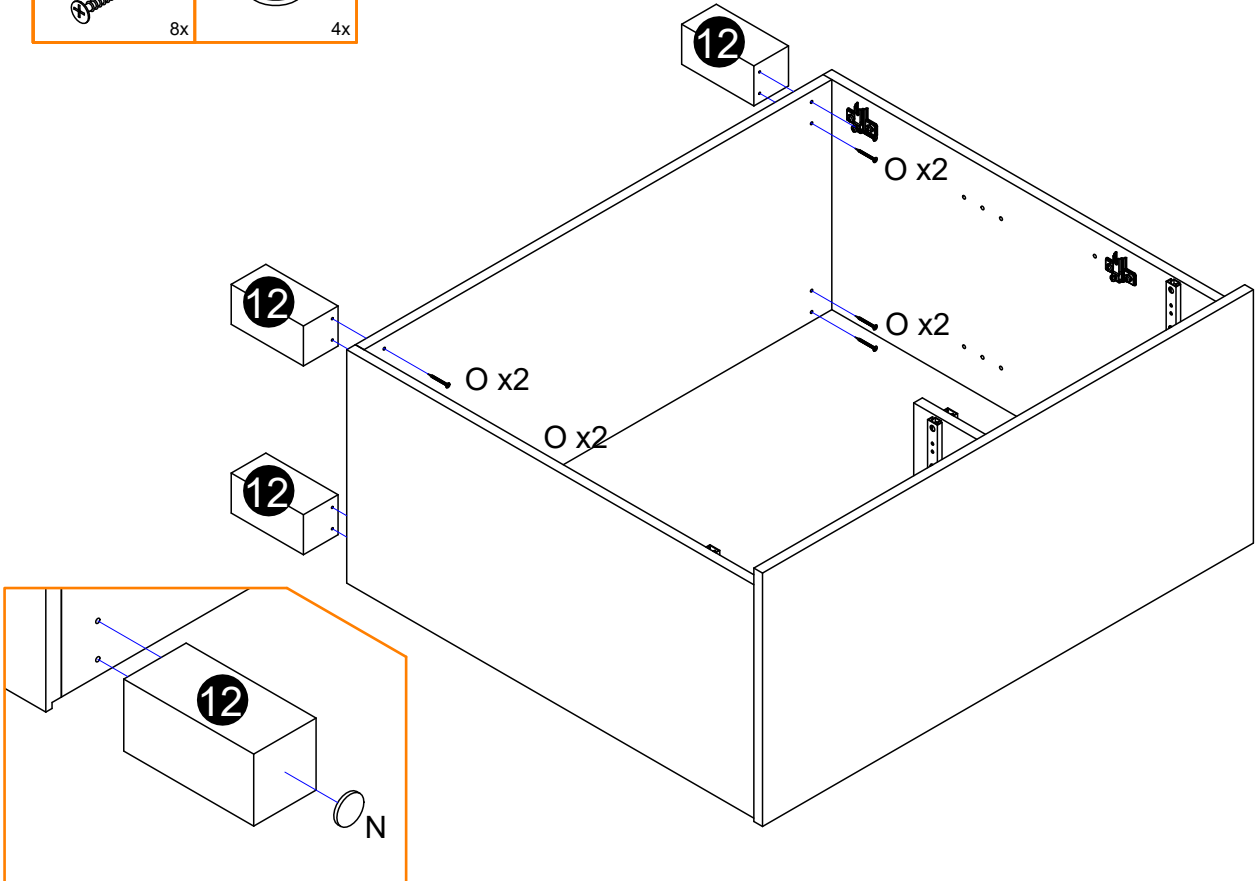
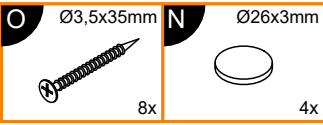

8

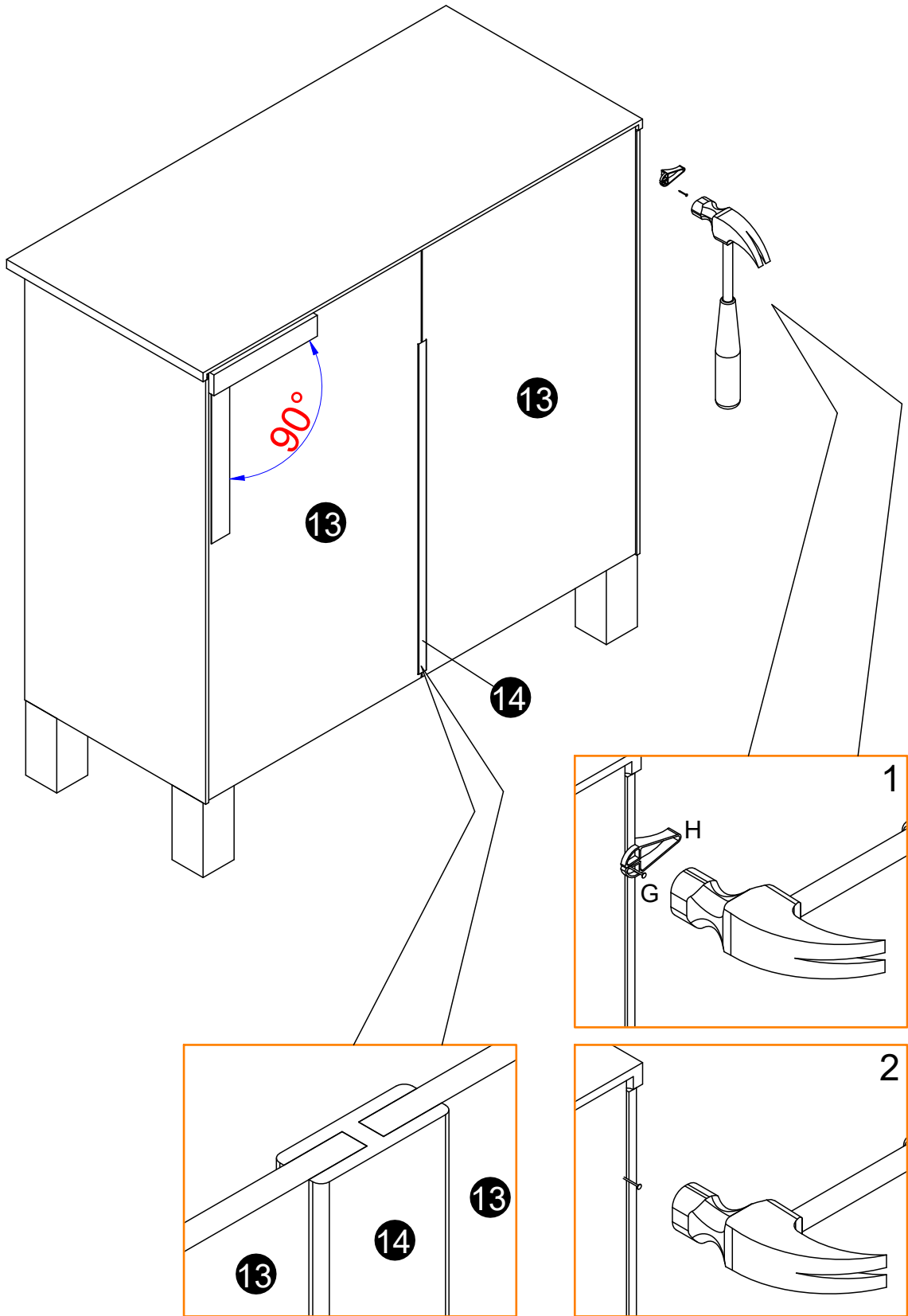
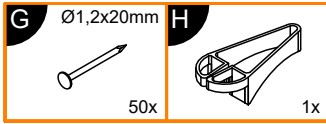

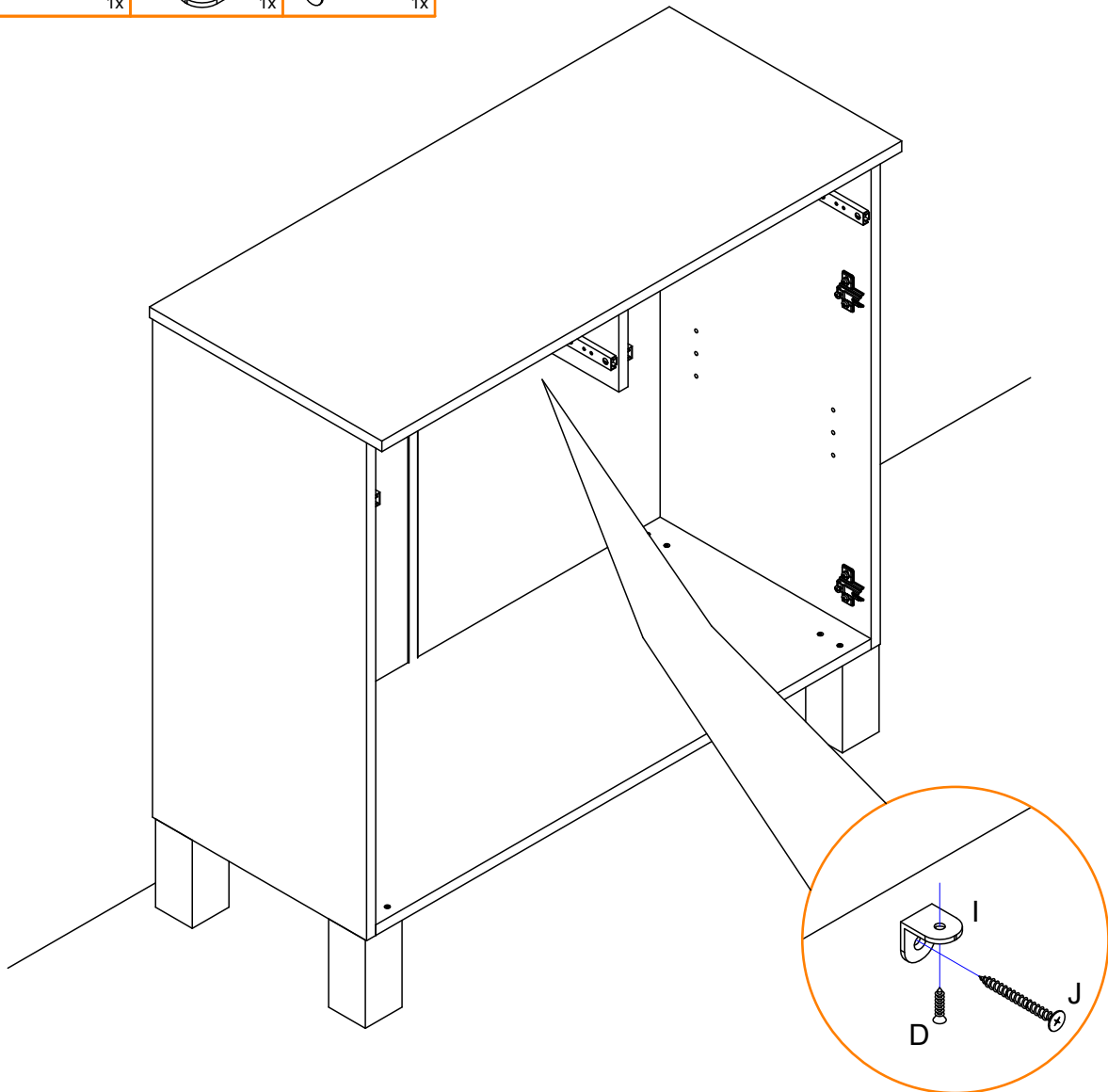
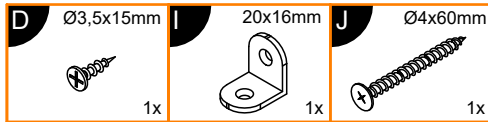



 <b>Achtung • Attention • Attenzione • Opgelet • Uwaga • Pozor • Figyelem • Aten ție</b> <b>• Dikkat • Внимание</b> 	
<b>(D)</b>	Wandbefestigung dient als Kippschutz - unbedingt anbringen! Bei einigen Wandtypen kann ein Spezialdübel erforderlich sein!
<b>(GB)</b>	The wall fastening serves to prevent tipping - be absolutely sure to mount it! For certain wall types, a special dowel may be necessary!
<b>(NL)</b>	Bevestiging aan de muur dient als kantelbescherming - zeker en vast bevestigen! Bij enkele muurtypes is een speciale plug misschien vereist!
<b>(PL)</b>	Mocowanie do ściany jest jednocześnie zabezpieczeniem przed przewróceniem - koniecznie zamontować! Do niektórych rodzajów ścian konieczne mogą być specjalne wkręty!
<b>(TR)</b>	Duvardaki sabitleme, devrilmeye kar ışı bir emniyet tedbiridir ve mutlaka monte edilmelidir! Baz ı duvar tiplerindebunun ı çin özel bir dübel gerekli olabilir!
<b>(RU)</b>	Обязательно установите крепление на стене во избежание опрокидывания! Для некоторых типов стен может потребоваться специальный дюбель!
<b>(FR)</b>	La fixation murale sert de protection contre le basculement — à installer impérativement ! Pour certains types de murs il faut des chevilles spéciales!
<b>(IT)</b>	Il fissaggio alla parete serve da protezione anti-ribaltamento - attaccarla assolutamente! Per alcune strutture di parete pu ò essere necessario un tassello speciale!
<b>(CZ)</b>	Montáž na stěnu slouží jako ochrana proti převrnutí - bezpodmínečně umístěte! U některých typů stěn může být zapotřebí speciální hmoždinka!
<b>(SK)</b>	Upevnenie na stenu slúži ako ochrana proti prevráteniu - bezpodmienečne použite! Pre niektoré druhy stien m ôže byť potrebná špeciálna hmoždinka!
<b>(HU)</b>	A terméket a falhoz kel rögzíténi, különben az felborulhat! Egyes falt ıpusoknál speciális tiplít kell használni!
<b>(RO)</b>	Sistemul de fixare la perete serve ște ca protecție la răsturnare de montat obligatoriu! Pentru unele tipuri de pere ți este posibil să fie necesar un diblu special!



11

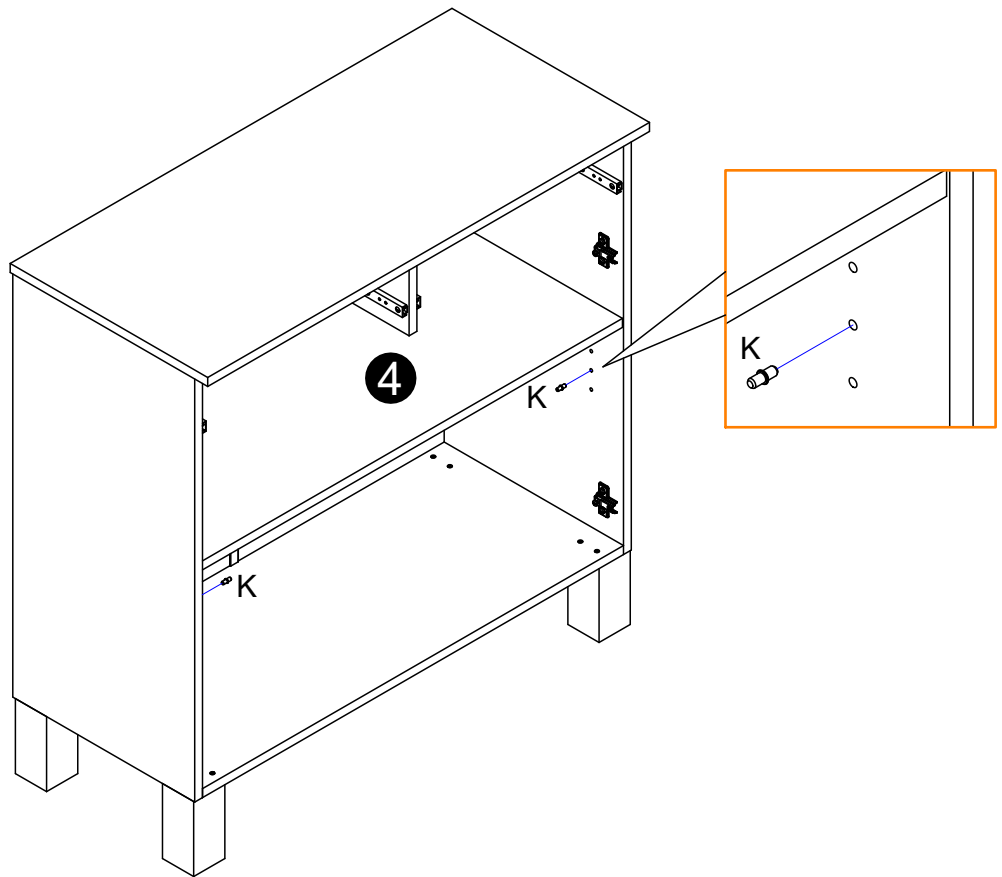
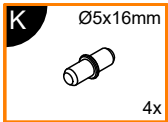

12

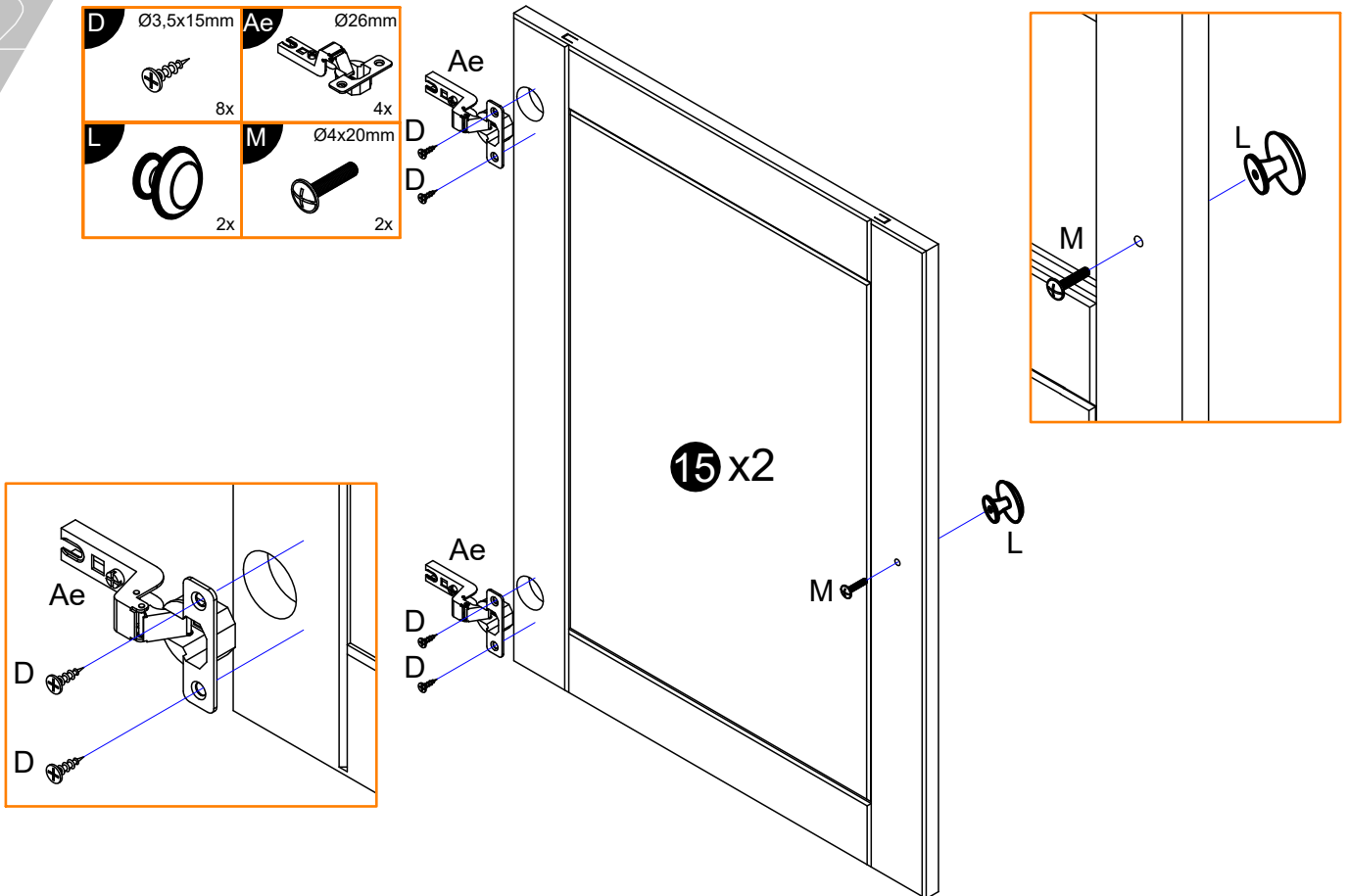
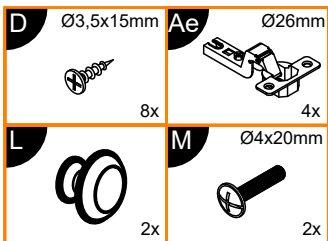

13

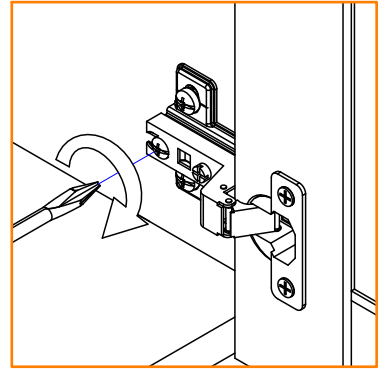
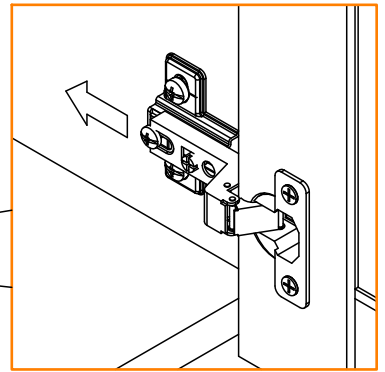
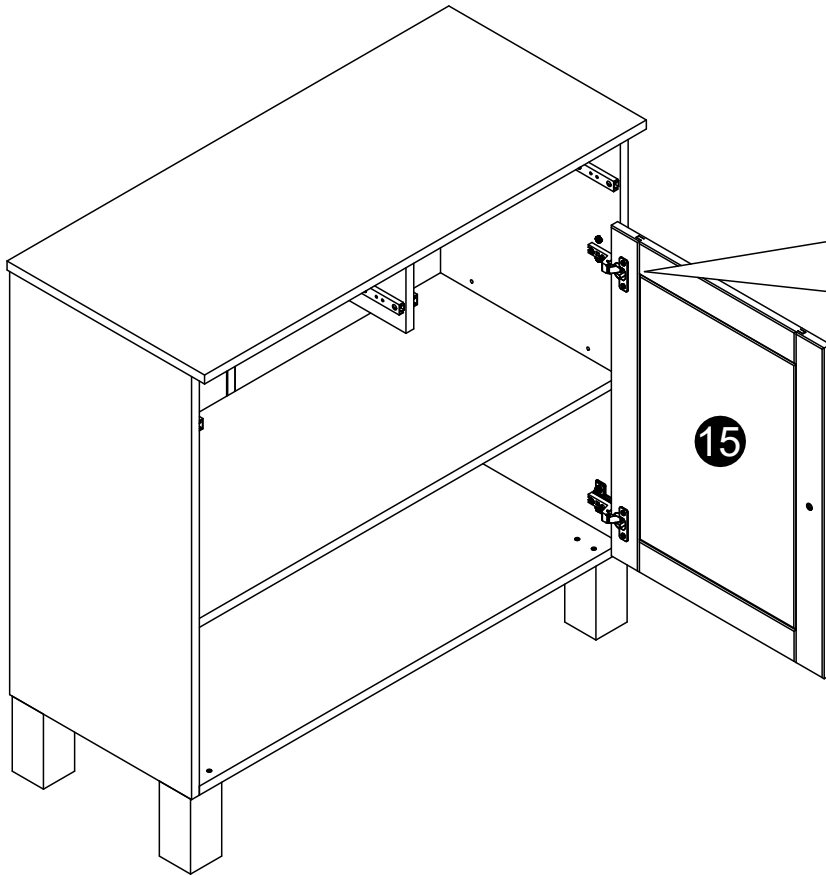

14

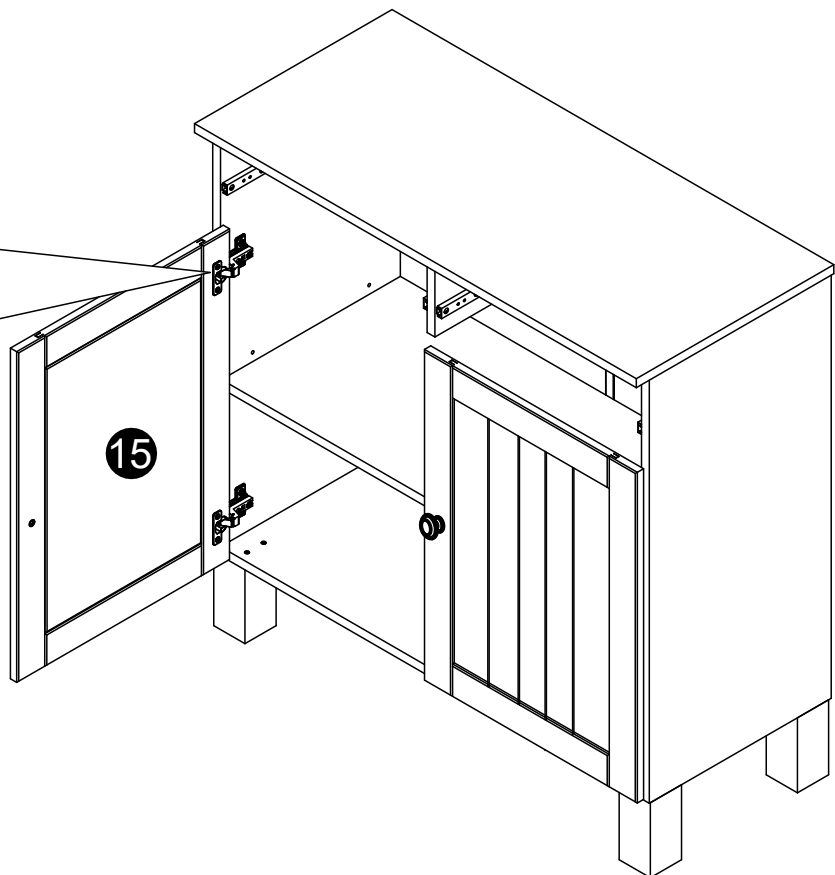
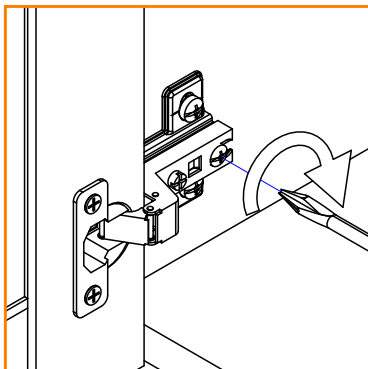
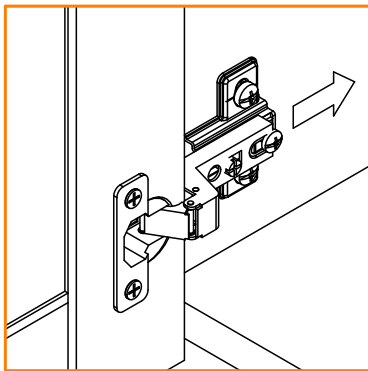

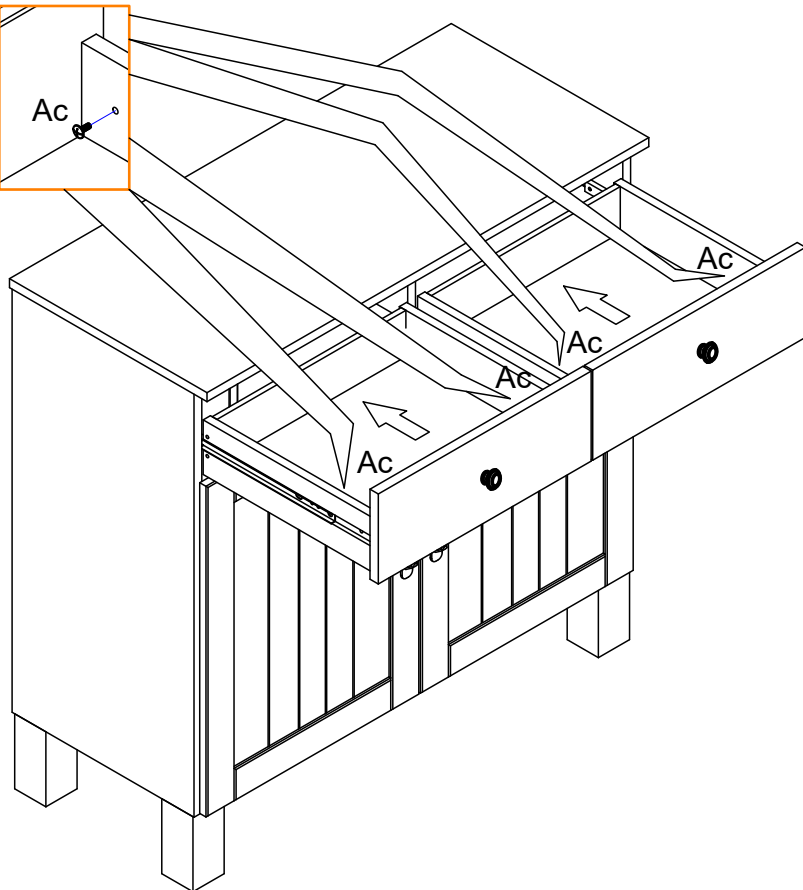
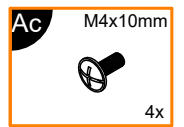
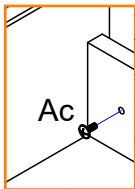
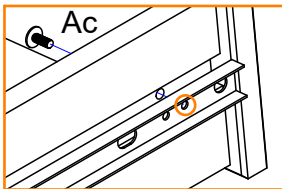
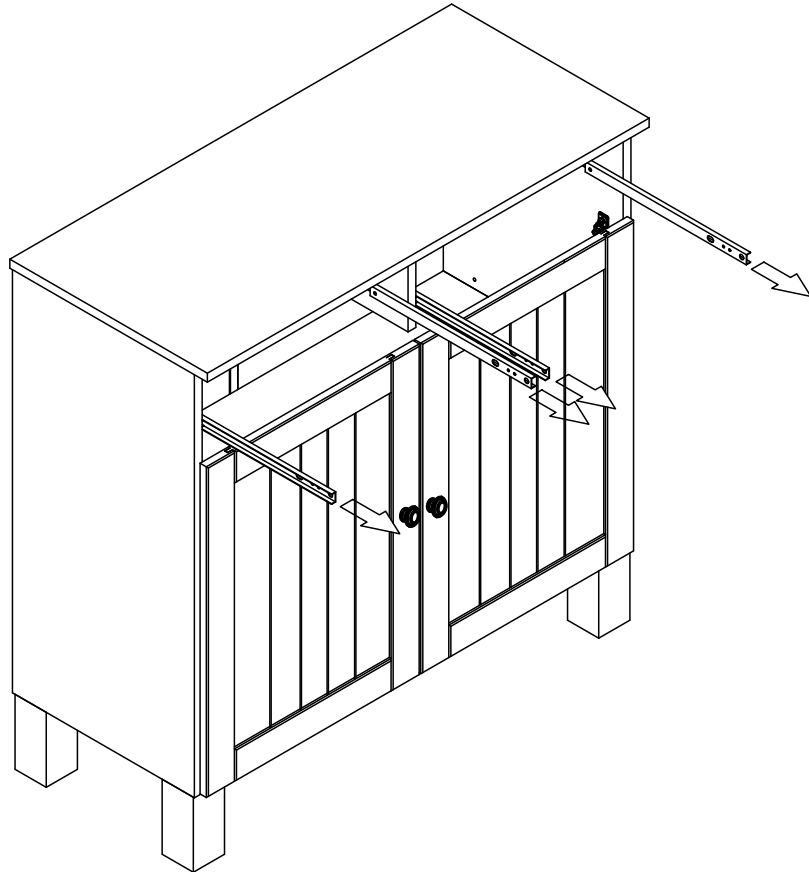

17

Türen einstellen (Scharniere justieren) Vyrovnajte dvířka (seřidte závěsy)  
 Adjusting the doors (adjusting the hinges) Nastavenie dverí (nastavenie závesov)  
 Régler les portes (ajuster les charnières) Állítsa be az ajtókat (állítsa be a zsanérokot)  
 Sistemare le porte (regolare le cerniere) Reglare uși (ajustare balamale)  
 Deuren instellen (scharnieren afstellen) Kapıların ayarlanması (menteşelerin seviye ayarı)  
 Nastawić drzwi (wyregulować zawiasy) Регулировка дверей (регулировка шарнира)

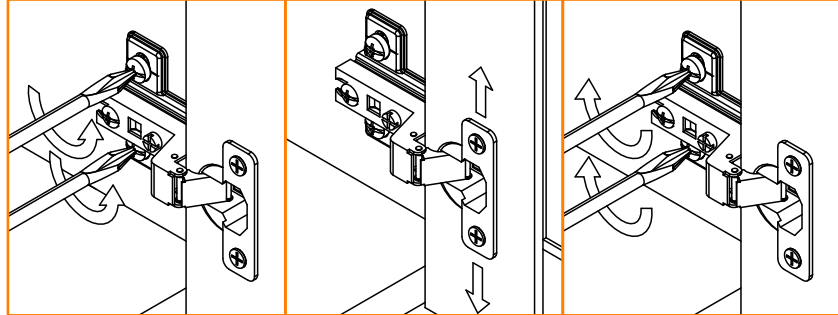
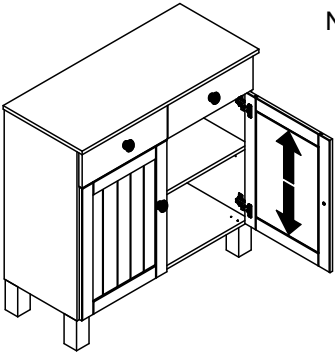

18

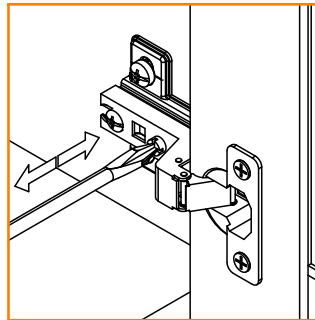
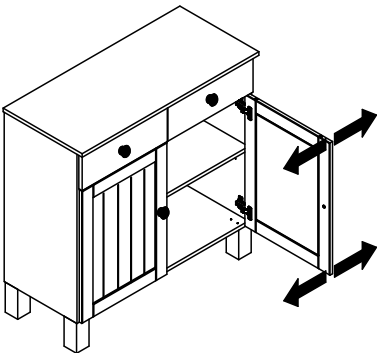

19

