

# ASSEMBLY INSTRUCTIONS

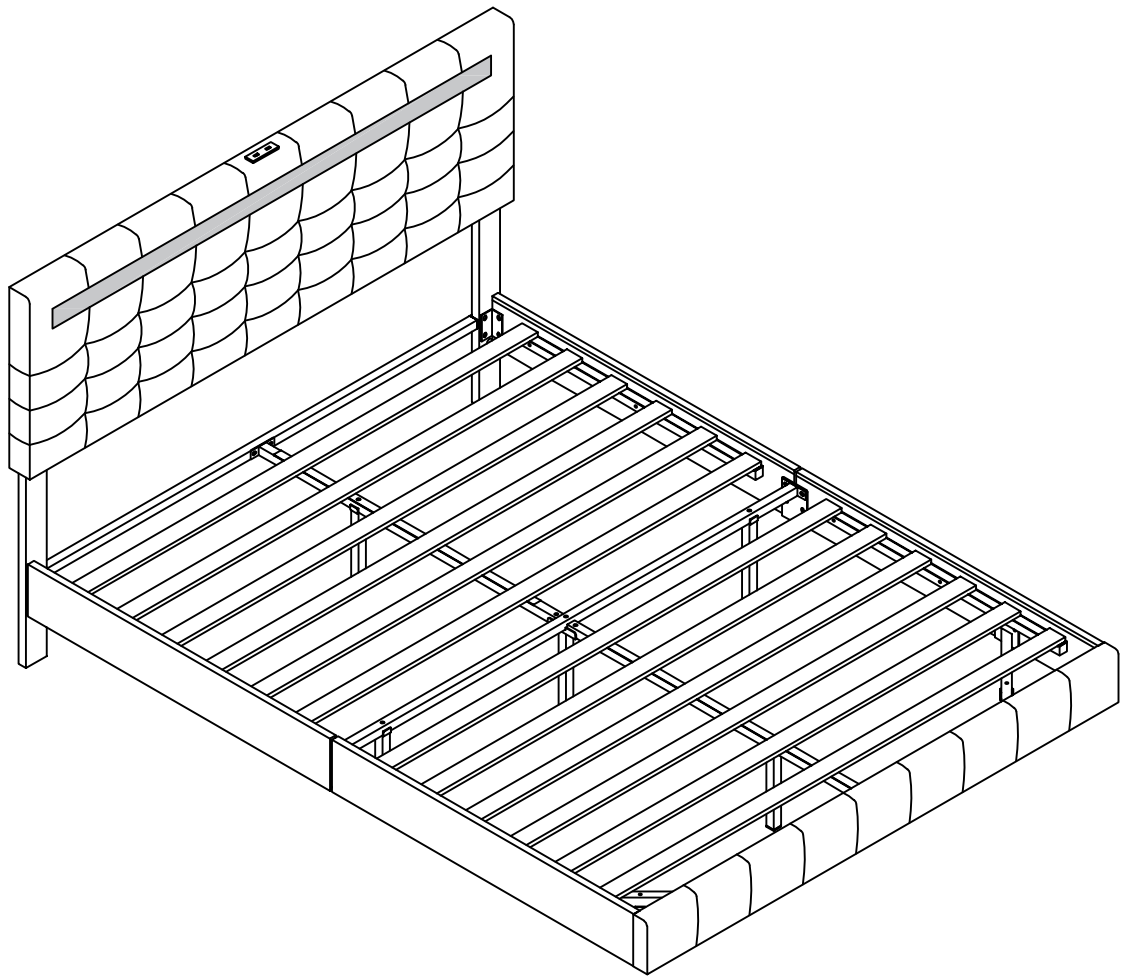

## TIPS

1. Please read the instructions fully before assembly. These instructions include important information which could ensure correct assembly.

We have been working on providing high quality products for you. However, in the rare instance that your product is defective, missing parts or there are some issues, please don't hesitate to contact our customer service to submit parts requirements, assembly suggestion, or warranty claims, and we will give the best solution as soon as possible.

If necessary, we need you to provide some more clear pictures of the issue.

2. Insert the screws in holes and tighten the screws, but not too tight, 70%~80% is ok, finally tighten all the screws. If some issues happened that some screws cannot target to the hole or some parts are difficult to install, please adjust the tightness of the screws.

3.2 people are recommended to finish

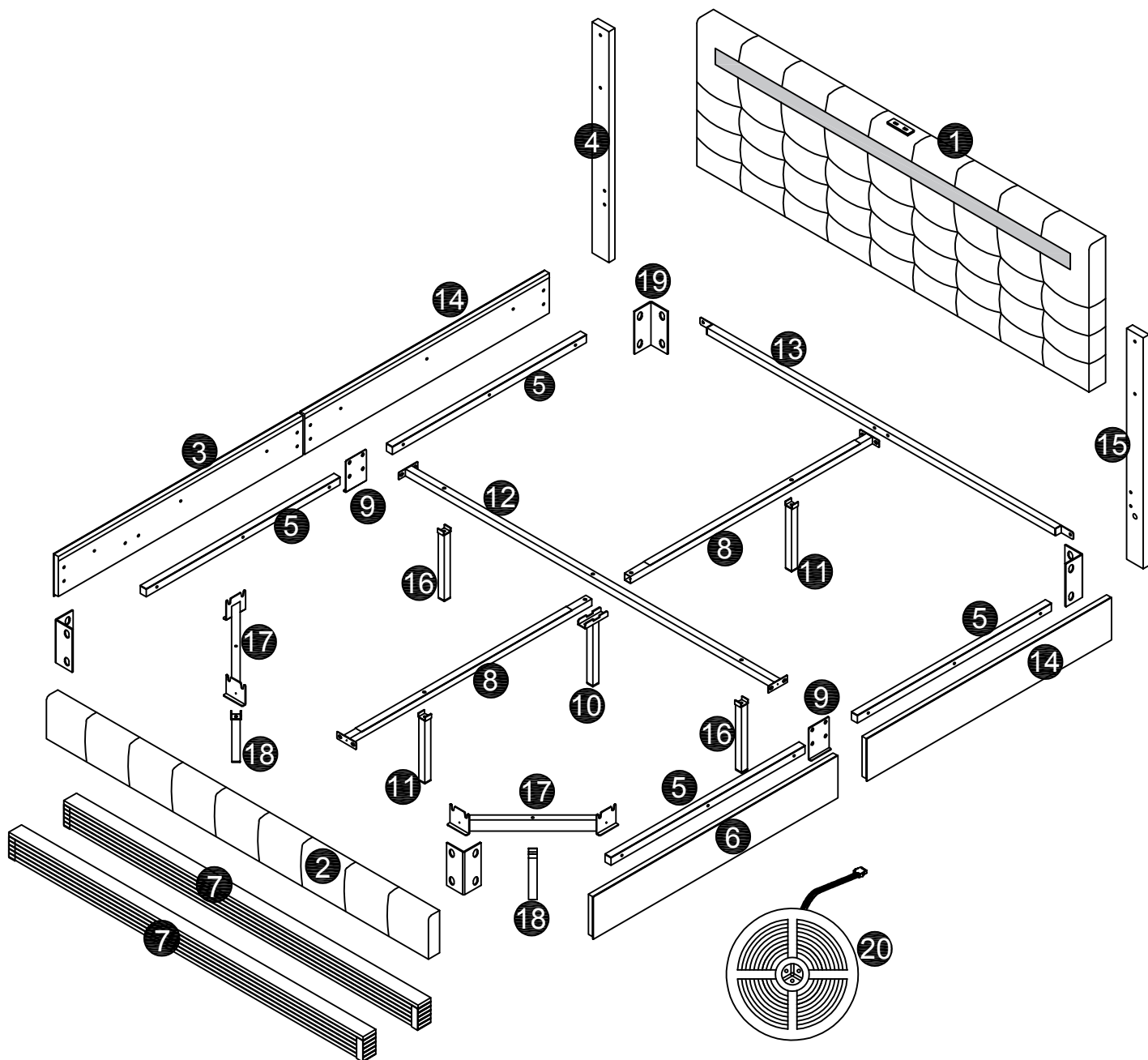

WF307779AAA / WF307781AAA

<b>1</b> x 1 	<b>3</b> x 1 	<b>4</b> x 1 	<b>6</b> x 1 	<b>12</b> x 1 
<b>13</b> x 1 	<b>15</b> x 1 	<b>20</b> x 1 		

WF307779AAA / WF307781AAA

<b>A</b> x 20 	<b>B</b> x 18 	<b>C</b> x 18 	<b>D</b> x 5 	<b>E</b> x 2 	<b>F</b> x 6 	<b>G</b> x 1 
-------------------	-------------------	-------------------	------------------	------------------	------------------	------------------



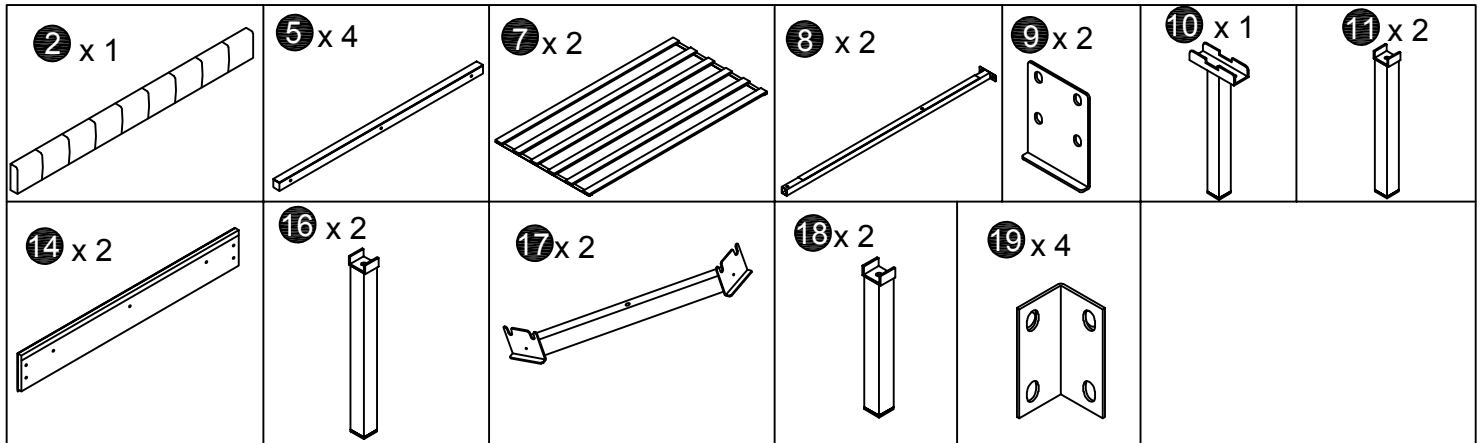



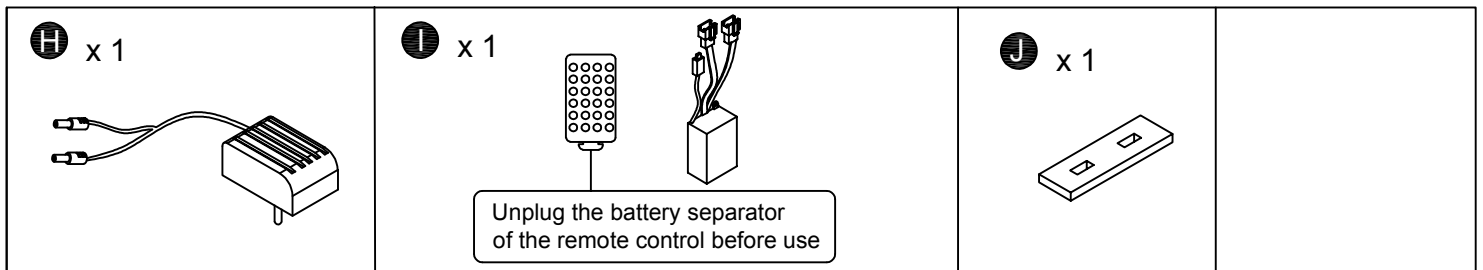



## WF307780AAA / WF307782AAA



## WF307780AAA / WF307782AAA



Part List		
NO.	ITEM	QTY
1	Headboard	1
2	Footboard	1
3	Front left Side Rails	1
4	Head board leg left	1
5	Side Rails Wood	4
6	Front Right Side Rails	1
7	Slats	2
8	Middle Iron Pipe	2
9	Connecting iron	2
10	Centre Support Leg	1
11	Front and back support Leg	2
12	Reinforced Pipe	1
13	Cross Rail for Metal Slat Frame	1
14	Side Rails After	2
15	Head board leg Right	1
16	Left and right support leg	2
17	Metal Corner Bracket	2
18	Footboard Leg	2
19	Angle Iron	4
20	Light bar	1

Part List		
NO.	ITEM	QTY
A	Bolts(M8x18mm) 	20
B	Bolts(M8x25mm) 	18
C	Bolts(M8x40mm) 	18
D	Bolts(M8x50mm) 	5
E	Bolts(M8x60mm) 	2
F	Flat washer 	6
G	hex wrench 	1
H	LED USB Power transformer 	1
I	Remote Control/ Controller 	1
J	USB Plastic 	1

Attention: Do not tighten the screws before completing the entire installation. If you have any difficulty with the installation process, please feel free to contact us.

## Step 1:

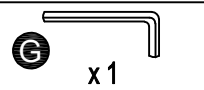
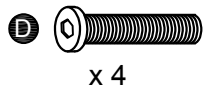

Fix the Head board leg left(4)/Head board leg Right(15) To the headboard(1) With Bolts (D) and Flat Washer (F) by using hex wrench (G), you can chose the holes 1 and 3 or 2 and 4 .  
(Fixieren Sie das Kopfplattenbein links(4)/Kopfplattenbein rechts(15) Zum Kopfteil(1) Mit Schrauben (D) und flacher Unterlegscheibe (F) mit Sechskantschlüssel (G), können Sie die Löcher 1 und 3 oder 2 und 4 wählen.)

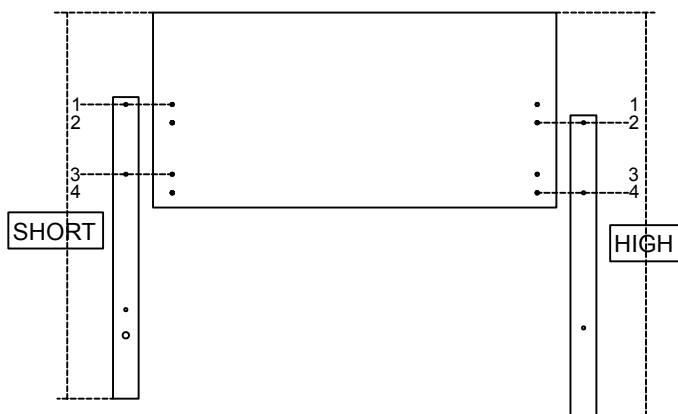
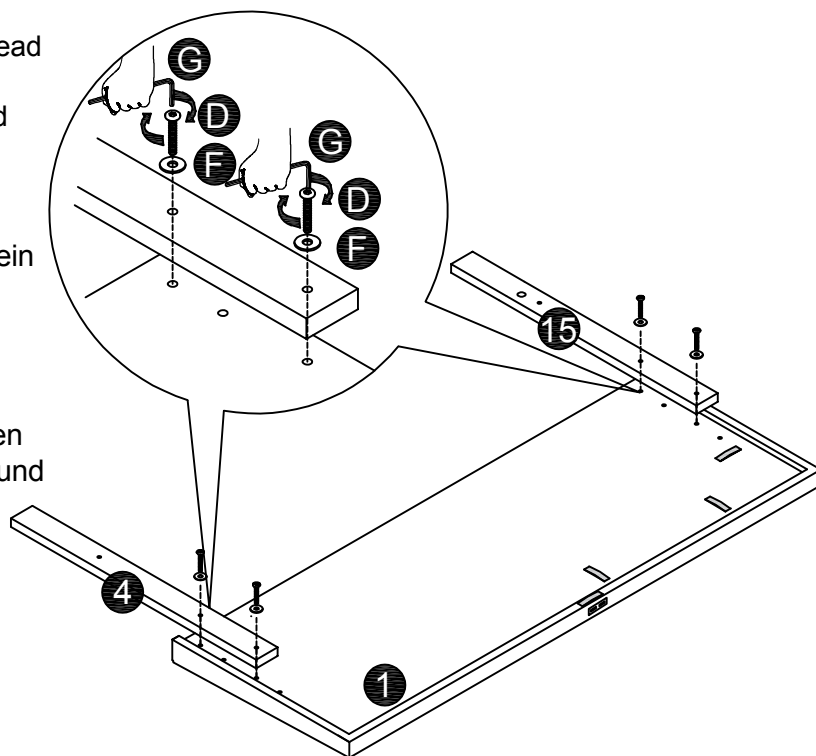

## Step 2:

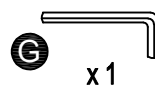
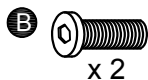

Fix the Cross Rail for Metal Slat Frame(13) to Head board leg left(4)/Head board leg Right(15) the Bolts (B) using hex wrench (G) .

(Befestigen Sie die Querschiene für Metalllamellenrahmen(11) zum Kopfplattenbein links(4)/Kopfplattenbein Rechts(15) die Bolzen (B) mit Sechskantschlüssel (G) .)

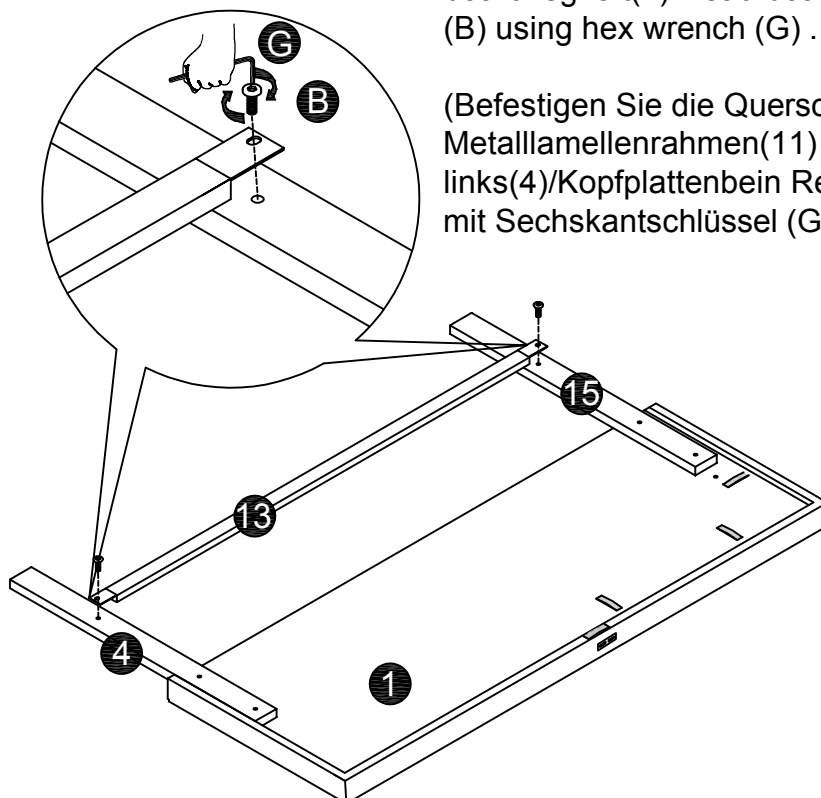

### Step 3:

Attention: Do not tighten the screws before completing the entire installation. If you have any difficulty with the installation process, please feel free to contact us.

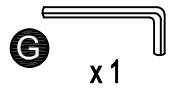
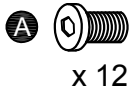

1. Fix the Angle Iron (19) To the Front Right Side Rails (6)/Side Rails After (14) With Bolts (A) by using hex wrench (G).
2. Use a hex wrench (G) to fix the Connecting iron (9) to the Front Right Side Rails (6) and Side Rails After (14) with bolts (B).

(1. Fixieren Sie das Winkeleisen (19) an den vorderen rechten Seitenschienen (6)/Seitenschienen nach (14) mit Schrauben (A) mit Sechskantschlüssel (G).  
2. Verwenden Sie einen Sechskantschlüssel (G), um das Verbindungseisen (9) an den vorderen rechten Seitenschienen zu befestigen (6) und Seitenschienen After (14) mit Schrauben (B).)

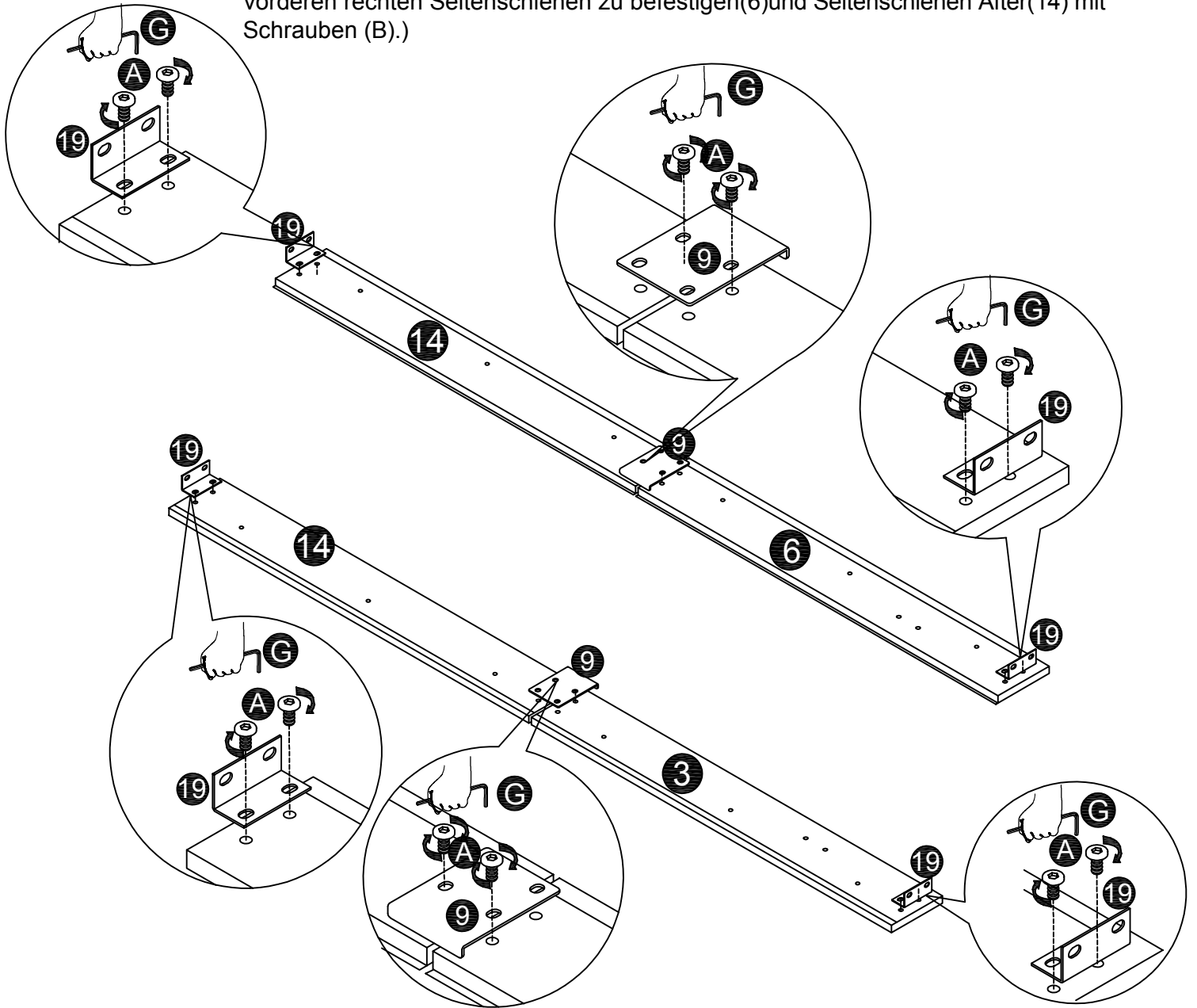

1. Fix the Angle Iron (19) To the Front left Side Rails (3)/Side Rails After (14) With Bolts (A) by using hex wrench (G).

2. Use a hex wrench (G) to fix the Connecting iron (9) to the Front left Side Rails (3) and Side Rails After (14) with bolts (B).

(1. Fixieren Sie das Winkeleisen (19) an den vorderen linken Seitenschienen (3)/Seitenschienen nach (14) mit Schrauben (A) mit Verwendung von Sechskantschlüssel (G).

2. Verwenden Sie einen Sechskantschlüssel (G), um das Verbindungseisen (9) an den vorderen linken Seitenschienen zu befestigen (3) und Seitenschienen After (14) mit Schrauben (B).)

## Step 4:

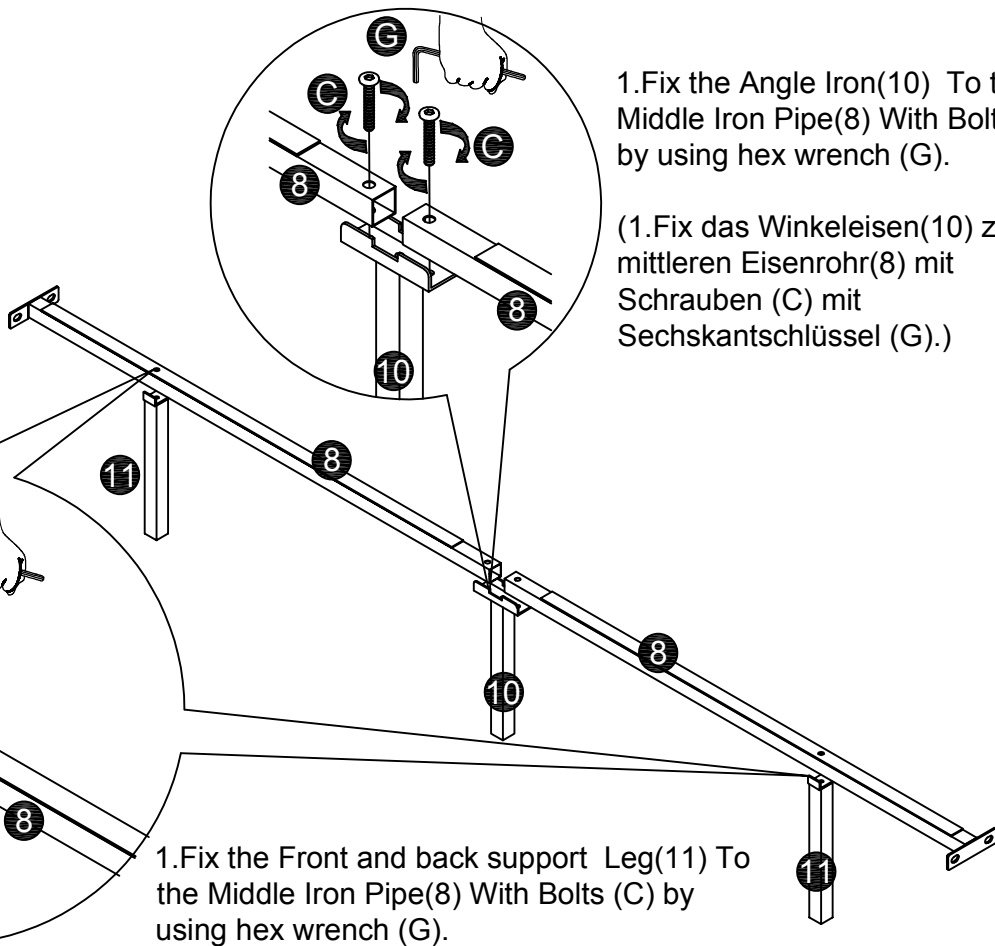
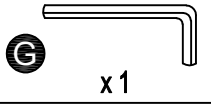
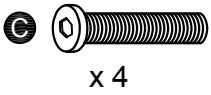

1. Fix the Angle Iron(10) To the Middle Iron Pipe(8) With Bolts (C) by using hex wrench (G).

(1. Fix das Winkeleisen(10) zum mittleren Eisenrohr(8) mit Schrauben (C) mit Sechskantschlüssel (G).)

1. Fix the Front and back support Leg(11) To the Middle Iron Pipe(8) With Bolts (C) by using hex wrench (G).

(1. Fixieren Sie das vordere und hintere Stützbein(11) zum mittleren Eisenrohr(8) mit Schrauben (C) mit Sechskantschlüssel (G).)

## Step 5:

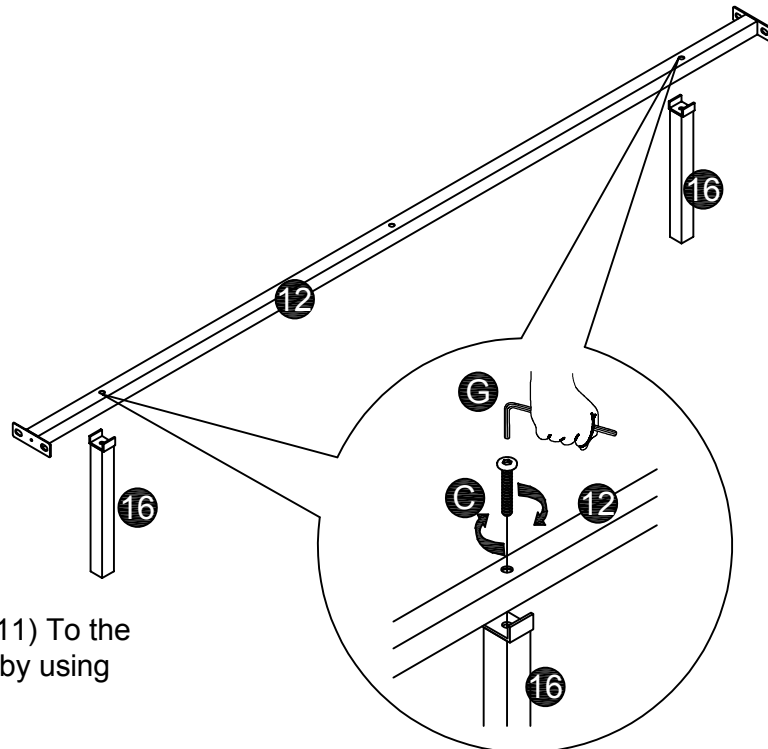
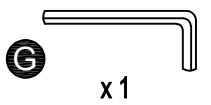
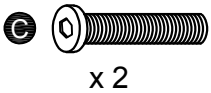

1. Fix the Left and right support leg(11) To the Reinforced Pipe(12) With Bolts (C) by using hex wrench (G).

(1. Fixieren Sie das linke und rechte Stützbein(11) an das verstärkte Rohr(12) mit Schrauben (C) mit Sechskantschlüssel (G).)

## Step 6:

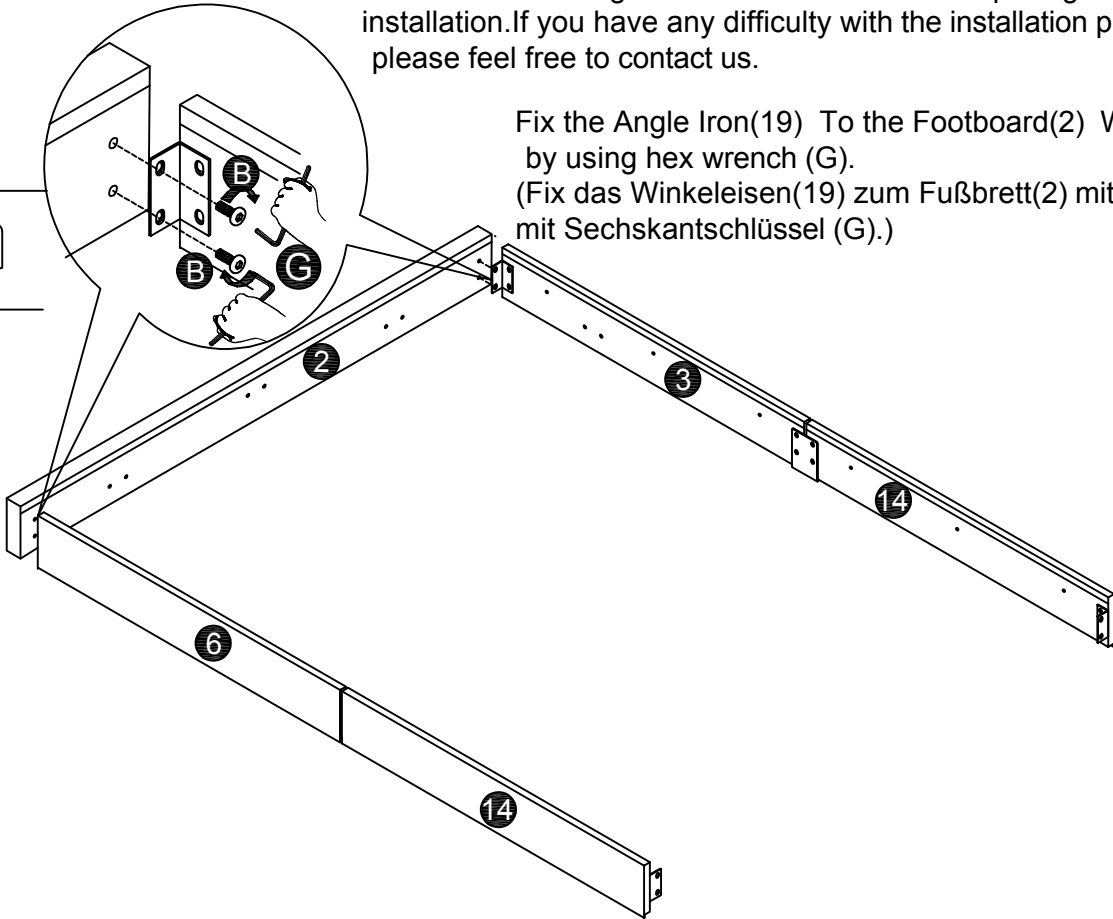
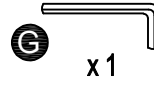
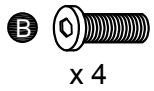

Attention: Do not tighten the screws before completing the entire installation. If you have any difficulty with the installation process, please feel free to contact us.

Fix the Angle Iron(19) To the Footboard(2) With Bolts (A) by using hex wrench (G).  
(Fix das Winkeleisen(19) zum Fußbrett(2) mit Schrauben (A) mit Sechskantschlüssel (G).)

## Step 7:

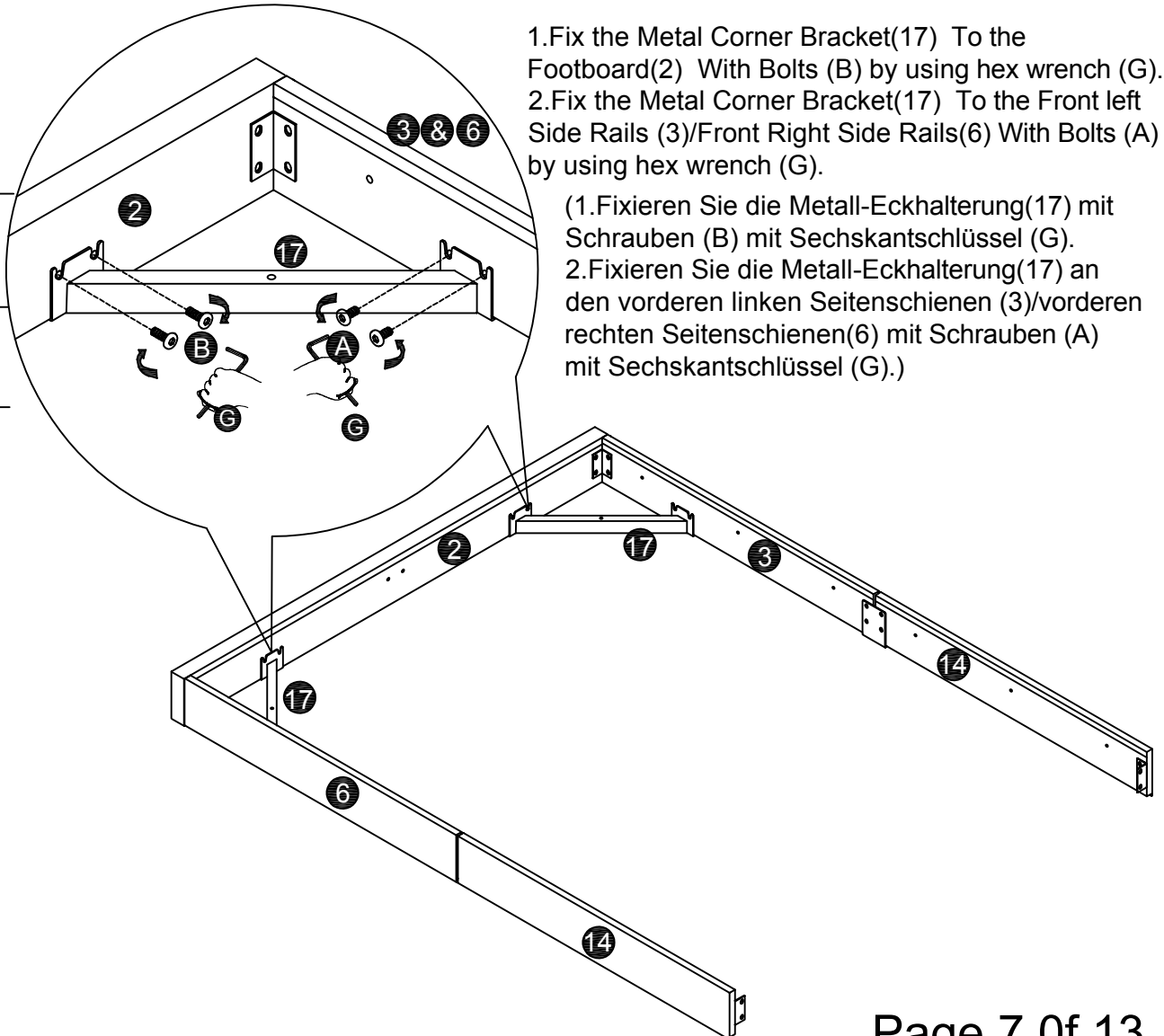
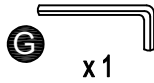
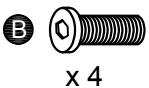
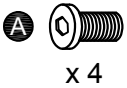

1. Fix the Metal Corner Bracket(17) To the Footboard(2) With Bolts (B) by using hex wrench (G).  
2. Fix the Metal Corner Bracket(17) To the Front left Side Rails (3)/Front Right Side Rails(6) With Bolts (A) by using hex wrench (G).

(1. Fixieren Sie die Metall-Eckhalterung(17) mit Schrauben (B) mit Sechskantschlüssel (G).  
2. Fixieren Sie die Metall-Eckhalterung(17) an den vorderen linken Seitenschienen (3)/vorderen rechten Seitenschienen(6) mit Schrauben (A) mit Sechskantschlüssel (G).)

## Step 8:



x 4

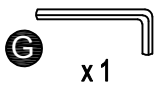

x 1

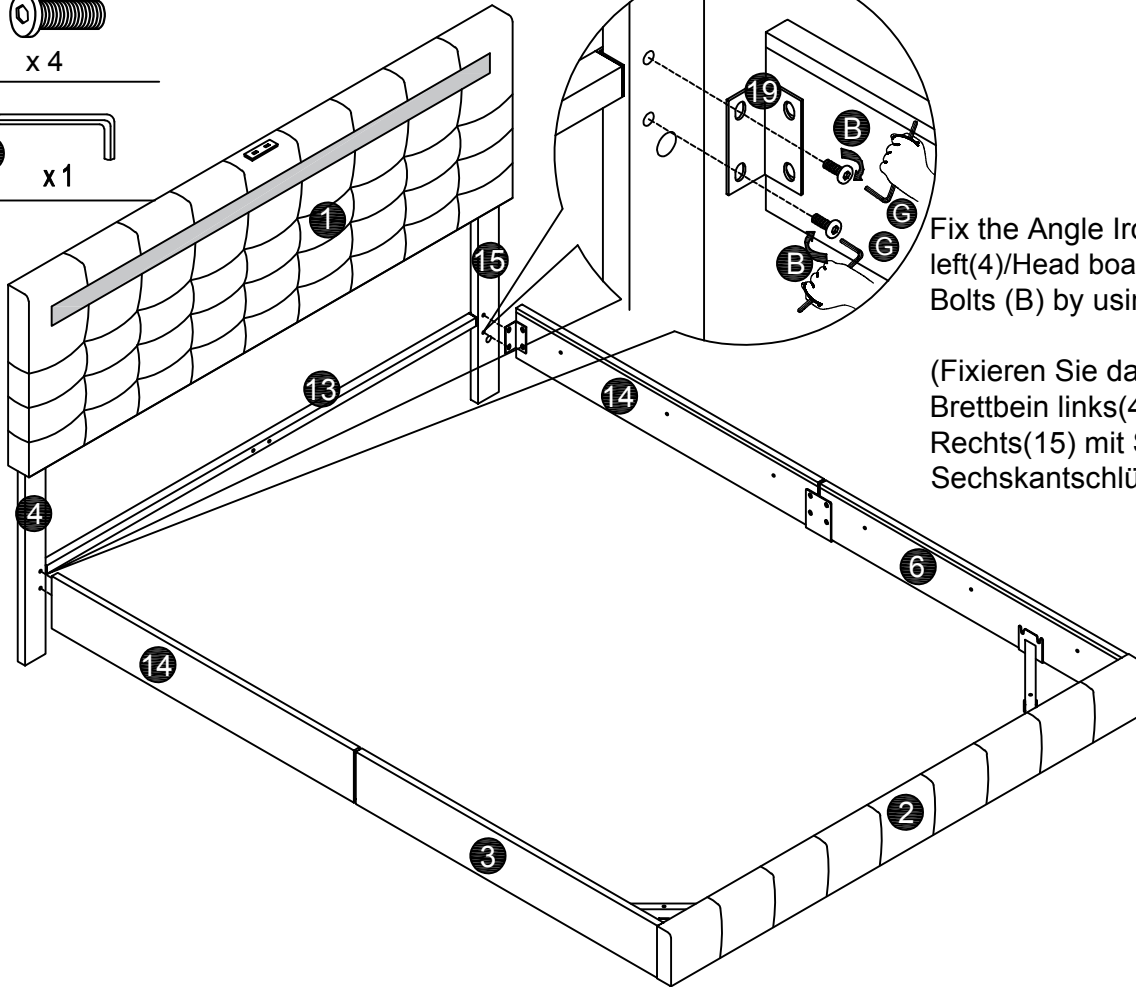

Fix the Angle Iron(19) To the board leg left(4)/Head board leg Right(15) With Bolts (B) by using hex wrench (G).

(Fixieren Sie das Winkeleisen(19) am Brettbein links(4)/Head Board Bein Rechts(15) mit Schrauben (B) mit Sechskantschlüssel (G).)

## Step 9:



x 4

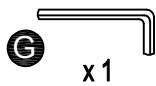

x 1

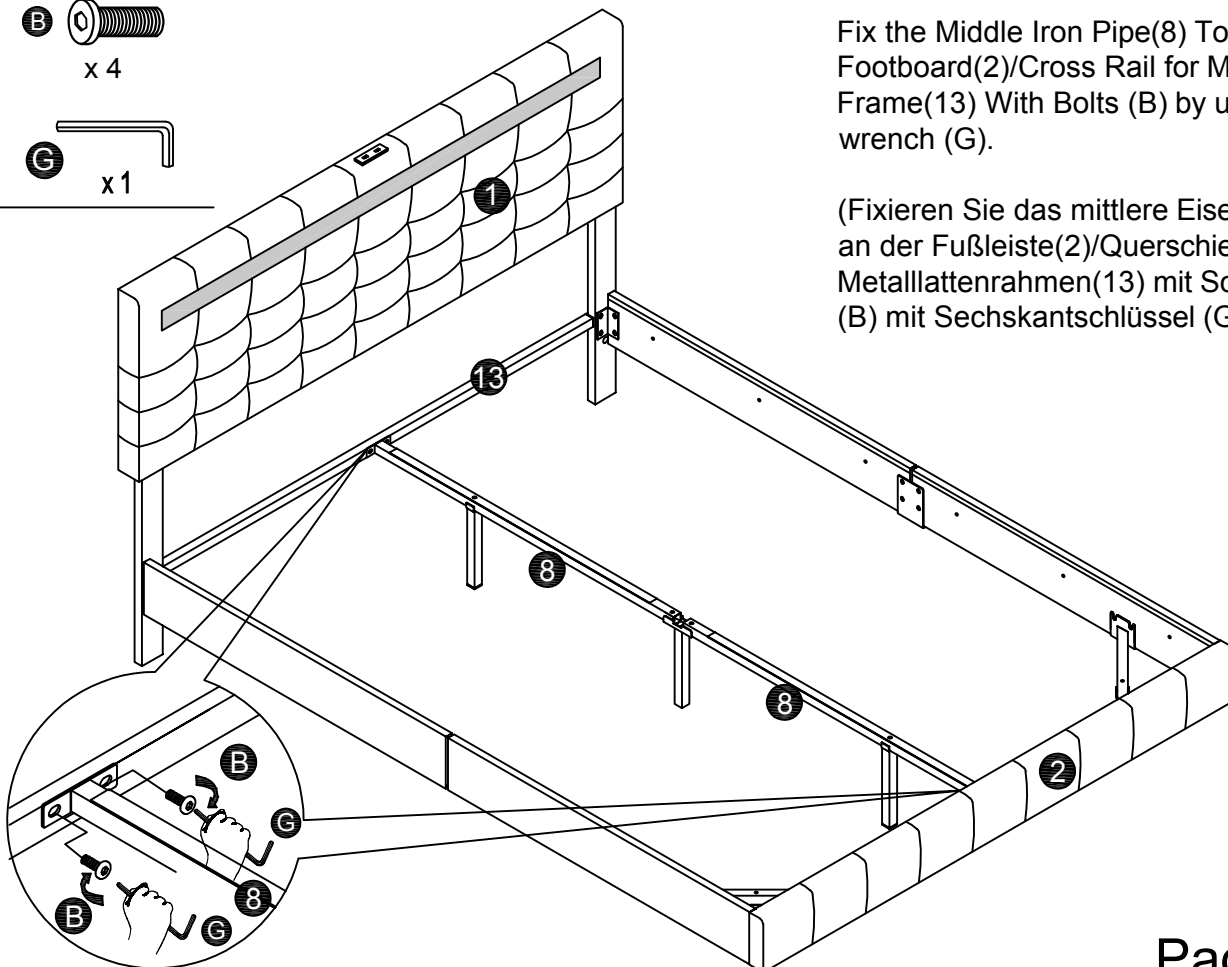

Fix the Middle Iron Pipe(8) To the Footboard(2)/Cross Rail for Metal Slat Frame(13) With Bolts (B) by using hex wrench (G).

(Fixieren Sie das mittlere Eisenrohr(8) an der Fußleiste(2)/Querschiene für Metalllattenrahmen(13) mit Schrauben (B) mit Sechskantschlüssel (G).)



## Step 10:

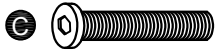

x 12



x 1

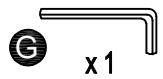

x 1

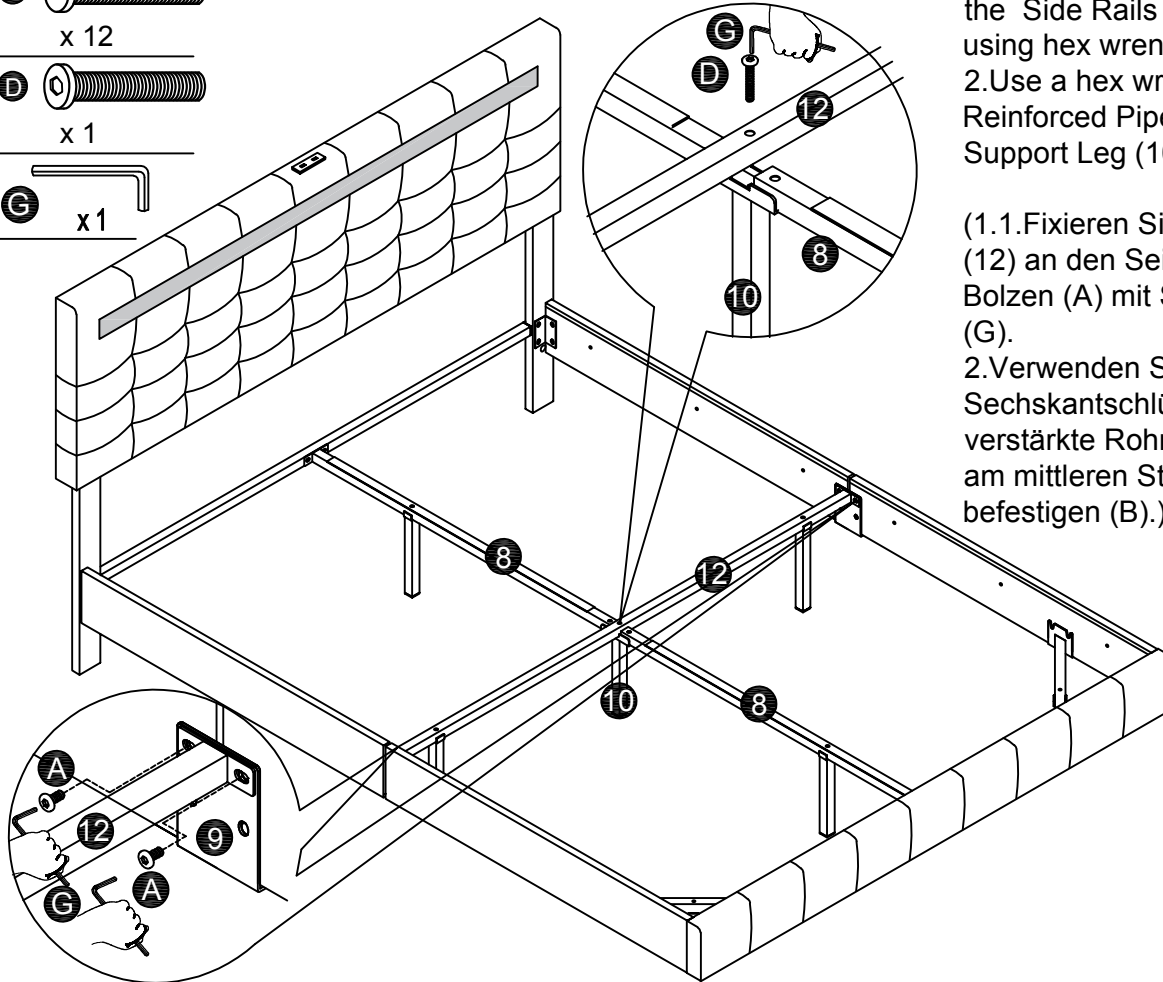

1. Fix the Reinforced Pipe (12) To the Side Rails With Bolts (A) by using hex wrench (G).
2. Use a hex wrench (G) to fix the Reinforced Pipe (12) to the Centre Support Leg (10) with bolts (B).

(1.1. Fixieren Sie das verstärkte Rohr (12) an den Seitenschiene mit Bolzen (A) mit Sechskantschlüssel (G).  
2. Verwenden Sie einen Sechskantschlüssel (G), um das verstärkte Rohr (12) mit Schrauben am mittleren Stützbein (10) zu befestigen (B).)

## Step 11:

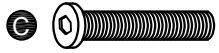

x 12



x 1

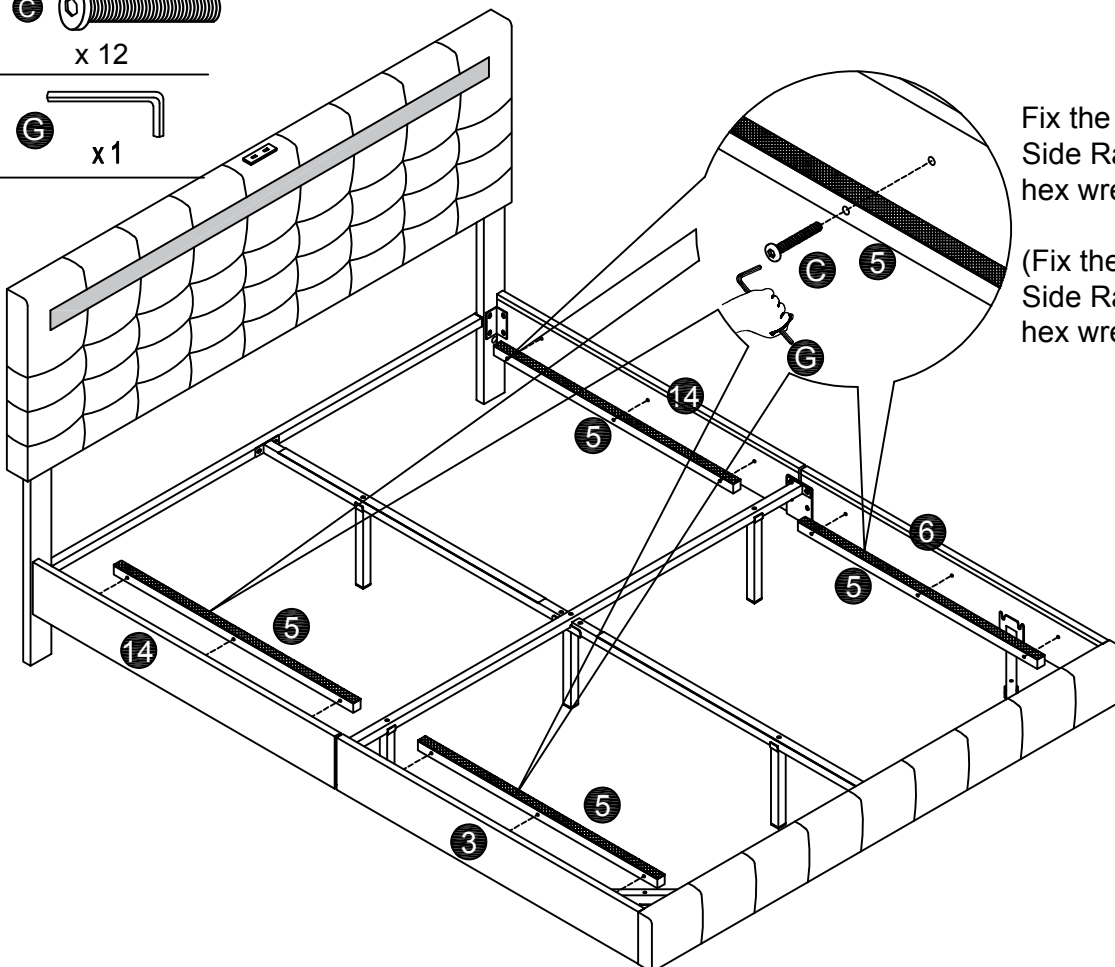

Fix the Side Rails Wood(5) To the Side Rails With Bolts (C) by using hex wrench (G).

(Fix the Side Rails Wood(5) To the Side Rails With Bolts (C) by using hex wrench (G).)

**Step 12:**

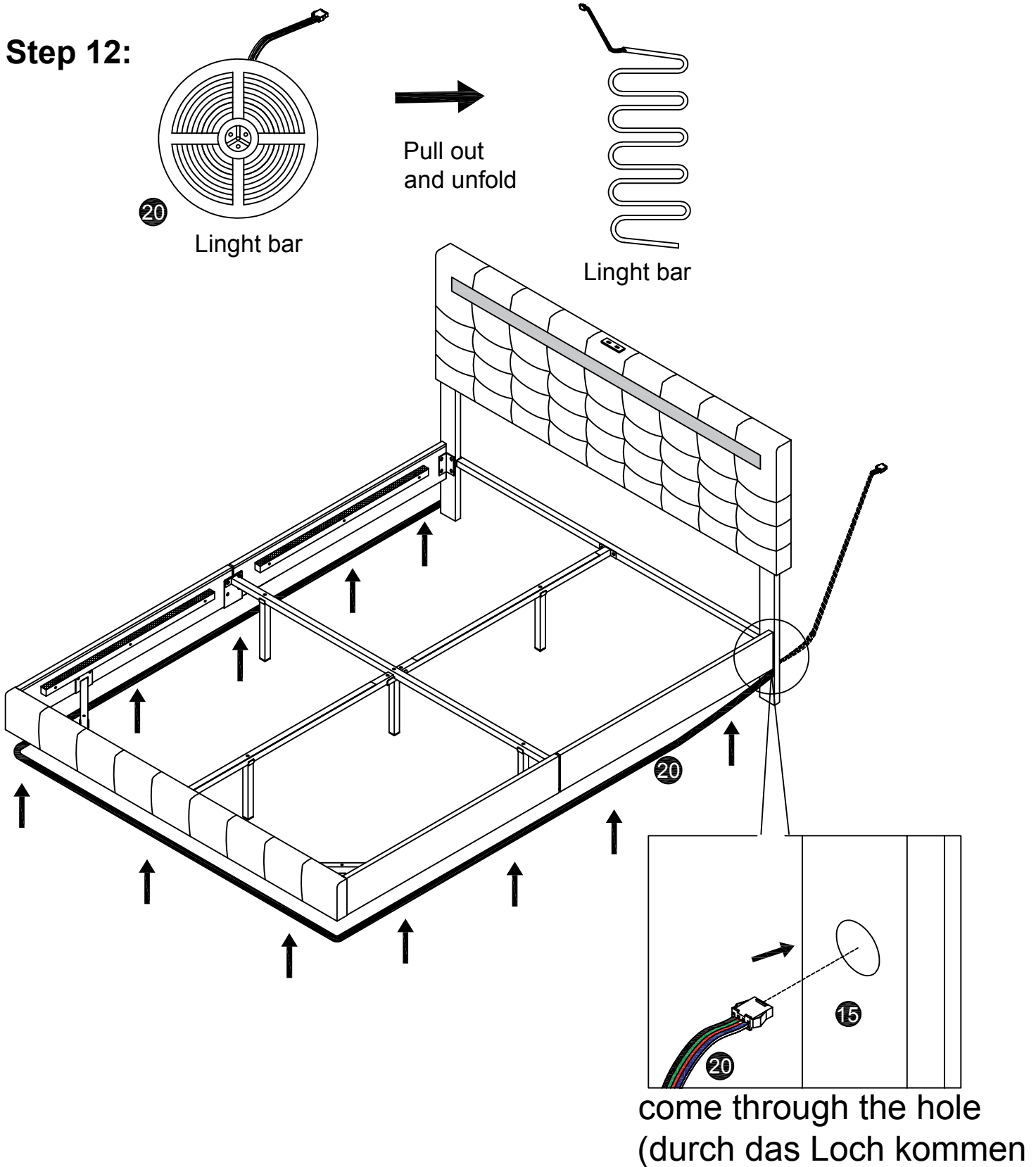

1. One side of the light bar is the luminous surface, and the other side is the velcro tape A.
  2. There are corresponding velcro tape B under the bed side and under the bed tail, which can be firmly bonded. Please fit the light belt to the bottom of the bed side.
- (1. Eine Seite der Lichtleiste ist die leuchtende Oberfläche, und die andere Seite ist das Klettband A.  
2. There sind entsprechendes Klettband B unter der Bettseite und unter dem Bettschwanz, das fest verbunden werden kann. Bitte befestigen Sie den Lichtgurt an der Unterseite des Bettes.)

## Step 13:

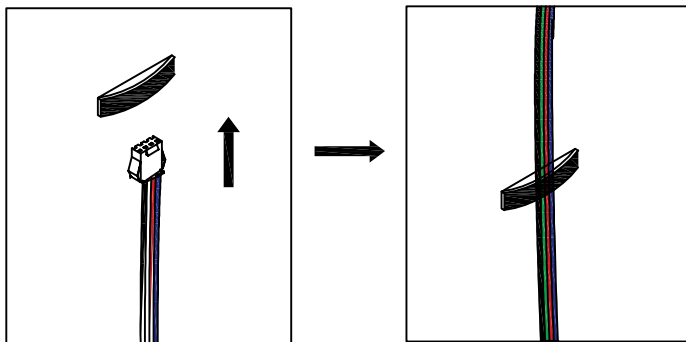

Please string the thread to the elastic band.  
(Bitte string der Faden zum Gummizug Band.)

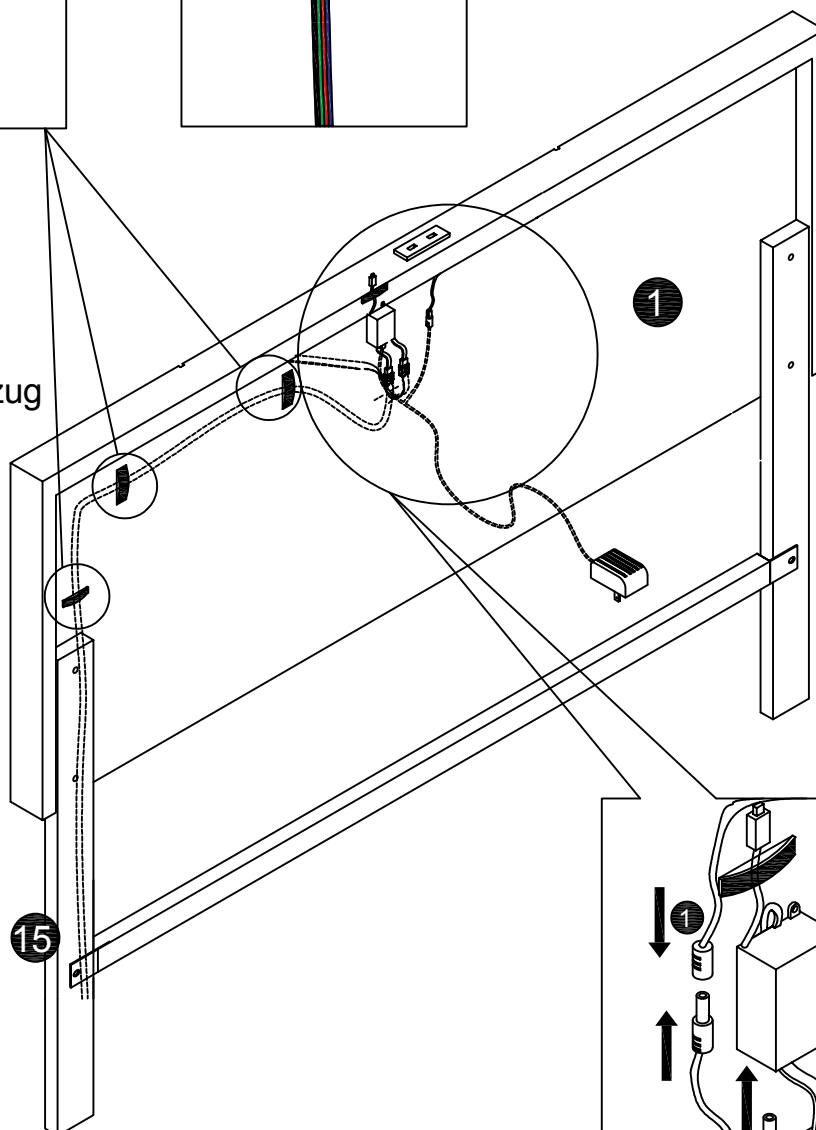

1. Please attach the infrared receiver to the elastic bag.
2. Controller (I) to the Light bar(20) / Headboard (1)
3. LED USB Power transformer to the Controller (I) / Headboard (1).

(1. Bitte befestigen Sie die Infrarot Empfänger in die elastische Tasche.  
2. Controller (I) zur Light Bar(20) / Headboard (1)  
3. LED USB Power Transformator zum Controller (I) / Kopfteil (1).)

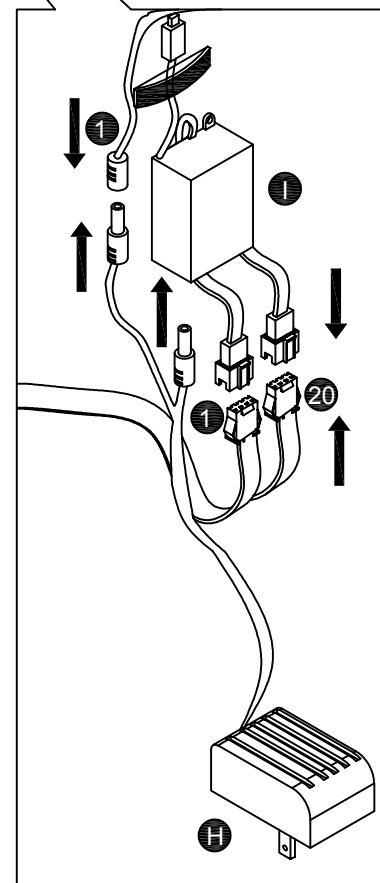

### Step 14:

Fix Slats(7) To the Side Rails  
Wood(5) .

(Befestigung Lamellen(7) an den  
Seitenschienen Holz(5) .)

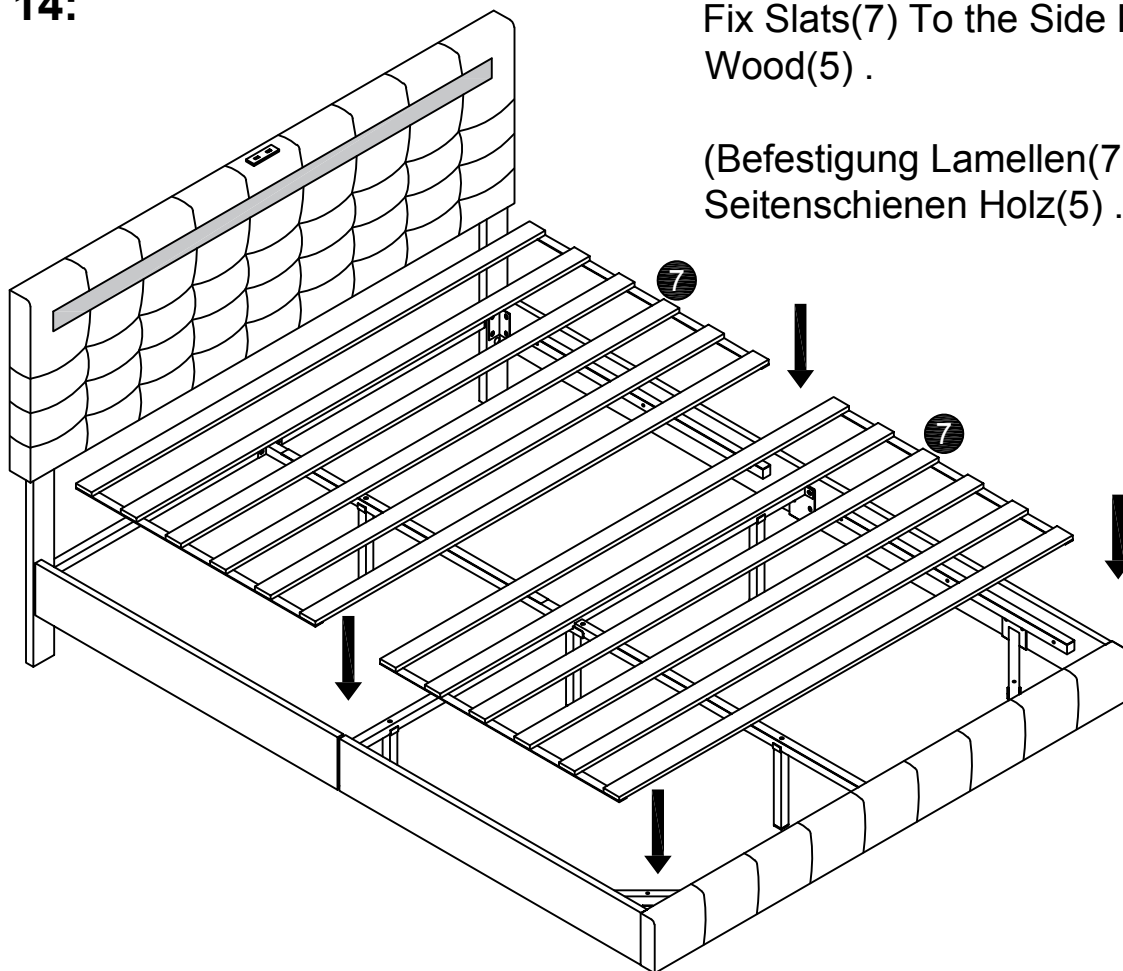

### Step 15:

Fix the USB Plastic(J) To the  
Headboard.

(Befestigen Sie den USB  
Kunststoff(J) am Kopfteil.)

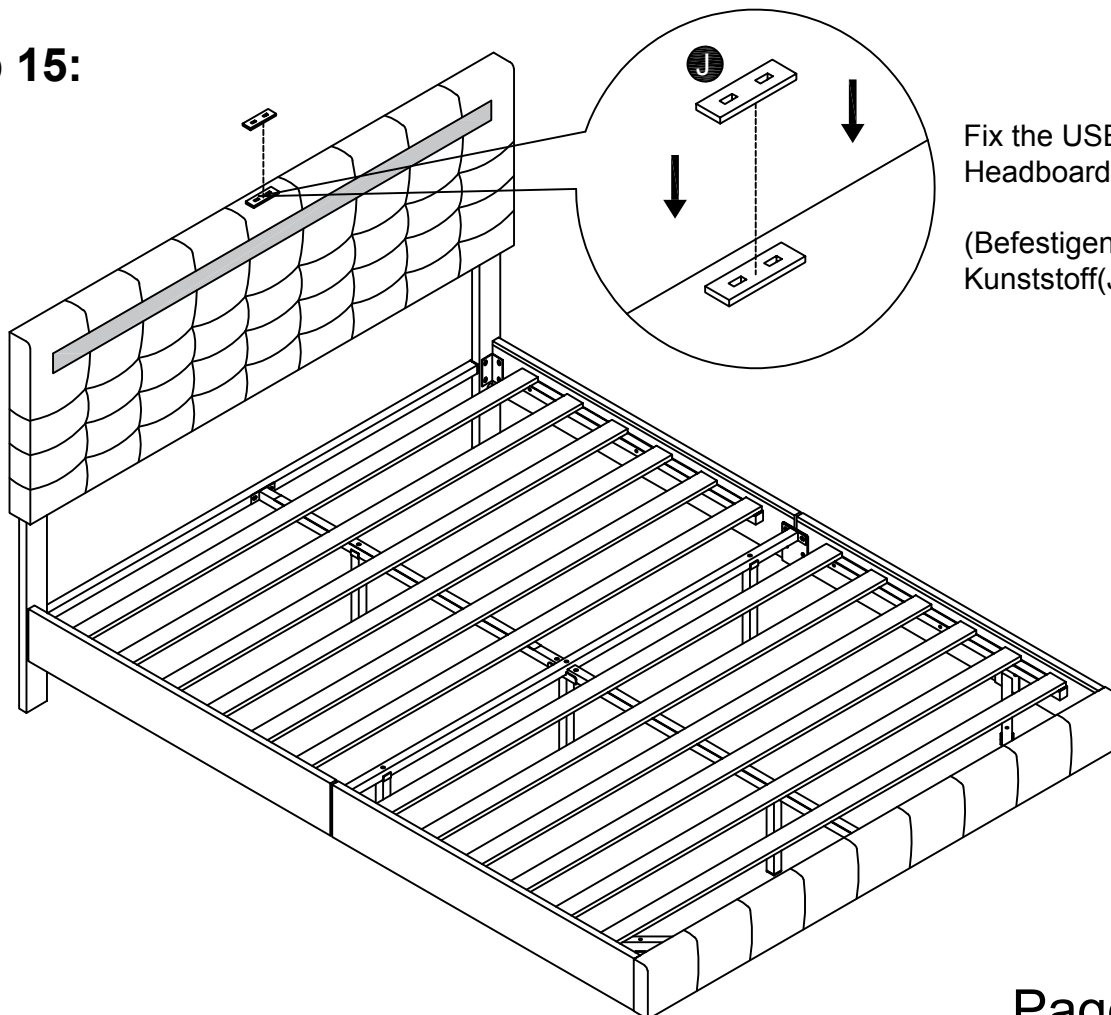

## LED light

If you can't let the lights work successfully, please check the following:

1. Please check the direction of the connect, try it in the opposite direction, according to the following picture.
2. Please check the remote control, it need you to tear down the plastic septum before use it.
3. If one of the colors is not bright, please check whether the four wires in the plug are skewed, and move the main line to make the four wires flush.

### (LED-Licht)

(Wenn Sie die Lampe nicht erfolgreich funktionieren lassen, überprüfen Sie bitte Folgendes:

1. Bitte überprüfen Sie die Verbindungsrichtung und versuchen Sie in der entgegengesetzten Richtung gemäß der Abbildung unten.
2. Bitte überprüfen Sie die Fernbedienung und entfernen Sie die Kunststoffmembran vor Gebrauch.
3. Wenn eine der Farben nicht hell ist, überprüfen Sie bitte, ob die vier Drähte im Stecker schief sind, und bewegen Sie die Hauptleitung, um die vier Drähte bündig zu machen.)

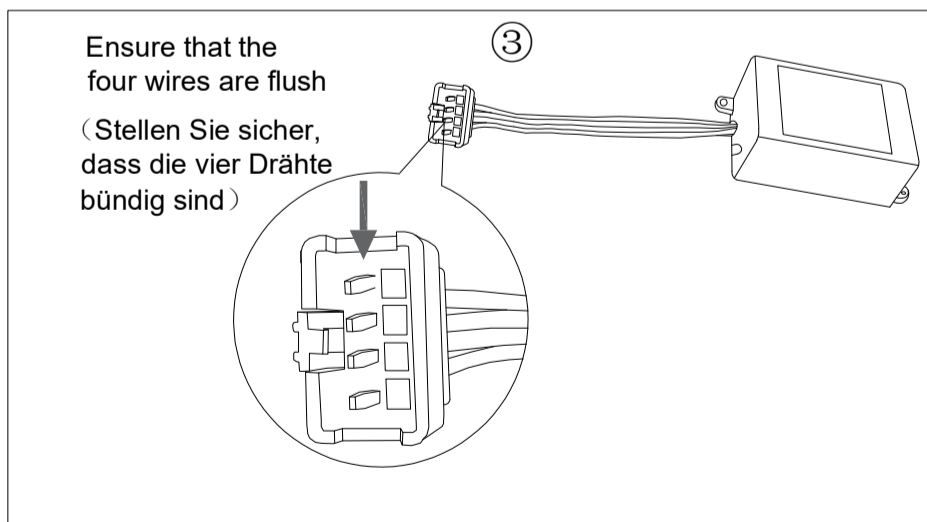
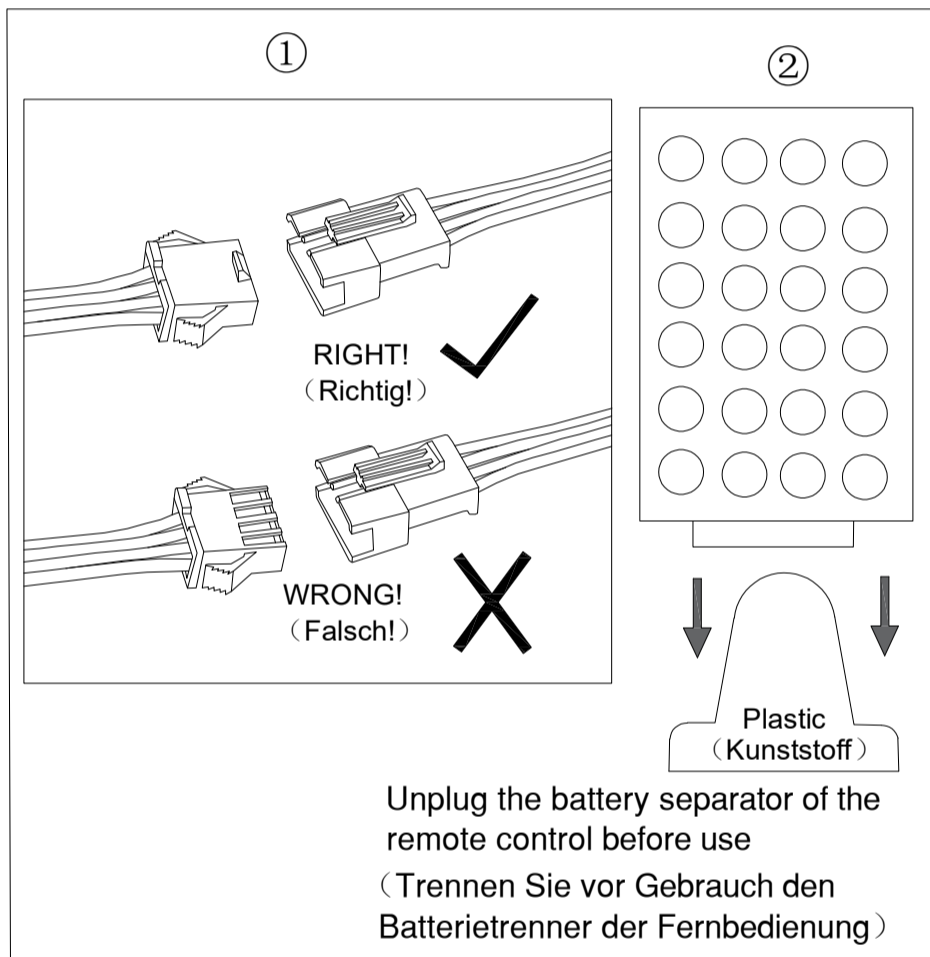

1. Please check the direction of the arrow
2. Please pull the plastic block out of the remote control
3. Please check whether the four wires of the plug are neat

1. Bitte überprüfen Sie die Richtung des Pfeils
2. Ziehen Sie bitte den Kunststoffblock von der Fernbedienung
3. Bitte überprüfen Sie, ob die vier Drähte des Steckers bündig sind)

## Operation Instructions of Controller (Betriebsanleitung des Reglers)

### I. Specifications: (Spezifikationen)

Working temperature: -20-60 °C  
(Arbeitstemperatur: -20-60 °C)

Supply voltage: DC12V  
(Versorgungsspannung: DC12V)

Product size: L62xW35xH23mm  
(Produktgröße: L62xW35xH23mm)

Package size: L95xW68xH45mm  
(Packungsgröße: L95xW68xH45mm)

Net weight: 42g  
(Nettogewicht: 42g)

Gross weight: 57g  
(Bruttogewicht: 57g)

Output: Three CMOS drain- open output  
(Ausgabe: Drei CMOS Drain- Open Ausgang)

Connecting Mode: Common anode  
(Verbindungsmodus: Gemeinsame Anode)

Max load current: 2 A each color  
(Maximaler Ladestrom: 2 A pro Farbe)

### II. Control Method:

Adopt RF remoter to control the led controller, which has 24 buttons, the function of each button as the table below:

(Kontrollmethode:

Nehmen Sie RF-Fernbedienung an, um den geführten Controller zu steuern, der 24-Tasten hat, die Funktion jeder Taste wie die Tabelle unten:)

Brightness +(Speed up) (Helligkeit +(Beschleunigung))	Brightness - (Speed down) (Helligkeit - (Geschwindigkeit runter))	Off (Aus)	On (Ein)
Static red (Statisches Rot)	Static green (Statisch grün)	Static blue (Statisch blau)	Static white (Statisch weiß)
Static orange (Statisch orange)	Static pea green (Statisches Erbsengrün)	Static dark blue (Statisch dunkelblau)	7 color jumpy change (7 Farbwechsel)
Static dark yellow (Statisch dunkelgelb)	Static cyan (Statisches Cyan)	Static brown (Statisch braun)	All fade out&fade in (All fade out&fade in)
Static yellow (Statisch gelb)	Static light blue (Statisch hellblau)	Static pink (Statisch rosa)	7 color fade change (7 Farbwechsel)
Static straw yellow (Statisches Strohgelb)	Static sky blue (Statisches Himmelblau)	Static purple (Statisches Lila)	3 base color jumpy (3 Grundfarbe nervös)

### III. Panel specification and connecting drawing as follows: (Plattenspezifikation und Anschlusszeichnung wie folgt)

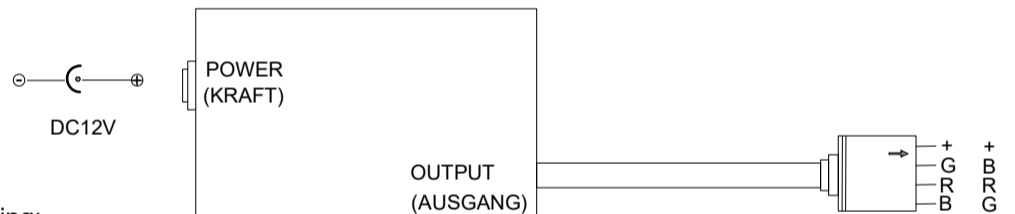

### IV. Warning:

1. Supply voltage of this product is DC12V never connect to DC24V or AC220V.
2. Never connect two wires directly in case of short circuit.
3. Lead wire should be connected correctly according to colors that connecting diagram offers.
4. Warranty of this product is one year, in this period we guarantee replacement or repairing with no charge, but exclude the artificial situation of damaged or overload working.

### (Warnung:

1. Supply Spannung dieses Produkts ist DC12V niemals mit DC24V oder AC220V verbinden.
2. Nie verbinden Sie zwei Drähte direkt im Falle eines Kurzschlusses.
3. Lead Draht sollte entsprechend den Farben richtig angeschlossen werden, die Verbindungsdiagramm anbietet.
4. Warranty dieses Produkts beträgt ein Jahr, in diesem Zeitraum garantieren wir Ersatz oder Reparatur ohne Gebühr, schließen aber die künstliche Situation der beschädigten oder überlasteten Arbeit aus.)

## ! WARNING

**THIS PRODUCT CONTAINS A BUTTON BATTERY**  
If swallowed, a lithium button battery can cause severe or fatal injuries within 2 hours.  
Keep batteries out of reach of children.  
If you think batteries may have been swallowed or placed inside any part of the body, seek immediate medical attention.

## ! WARNUNG

**Dieses Produkt enthält eine Knopf-batterie**  
Beim Verschlucken kann eine Lithium-Knopf-batterie innerhalb von zwei Stunden schwere oder tödliche Verletzungen verursachen.  
Bewahren Sie Batterien außerhalb der Reichweite von Kindern auf.  
Wenn Sie glauben, dass Batterien verschluckt oder in einen Teil des Körpers gelegt wurden, suchen Sie sofort einen Arzt auf.