

# »1366«

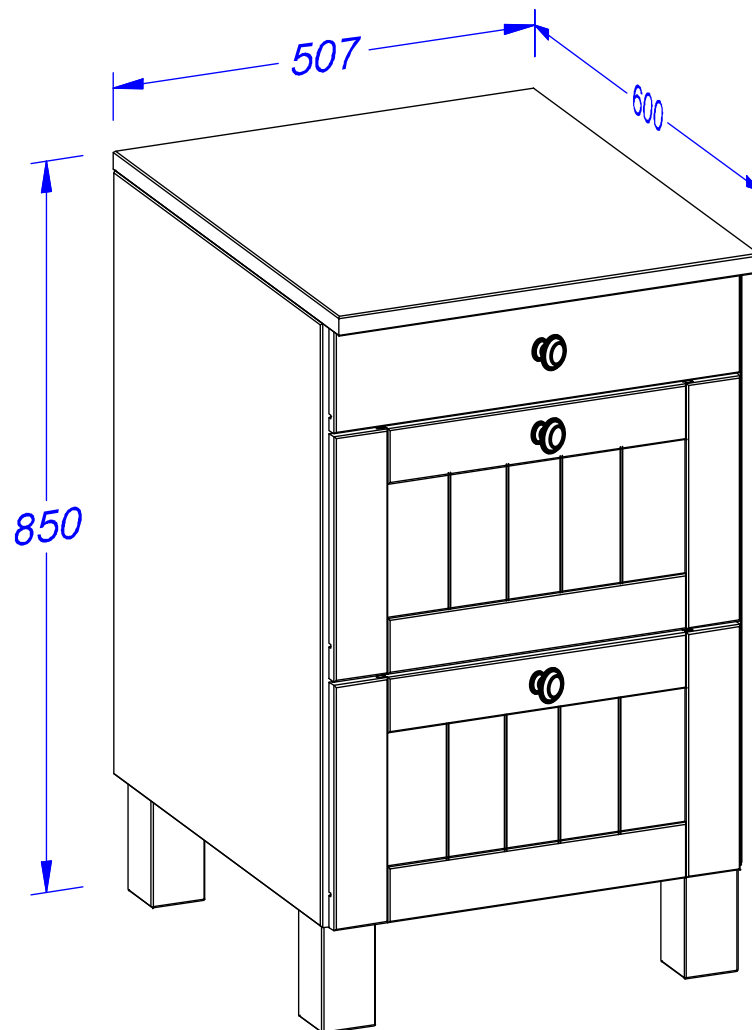

- |  |  |
|--|--|
| <b>(D)</b> <i>Montageanleitung</i>             | <b>(GB)</b> <i>Assembly instructions</i>   |
| <b>(NL)</b> <i>Handleiding voor de montage</i> | <b>(PL)</b> <i>Instrukcja montażu</i>      |
| <b>(TR)</b> <i>Montaj talimatı</i>             | <b>(RU)</b> <i>Инструкция по монтажу</i>   |
| <b>(FR)</b> <i>Notice de montage</i>           | <b>(IT)</b> <i>Istruzioni di montaggio</i> |
| <b>(CZ)</b> <i>Montážní návod</i>              | <b>(SK)</b> <i>Návod na montáž</i>         |
| <b>(HU)</b> <i>Szerelési útmutató</i>          | <b>(RO)</b> <i>Instrucțiuni de montaj</i>  |









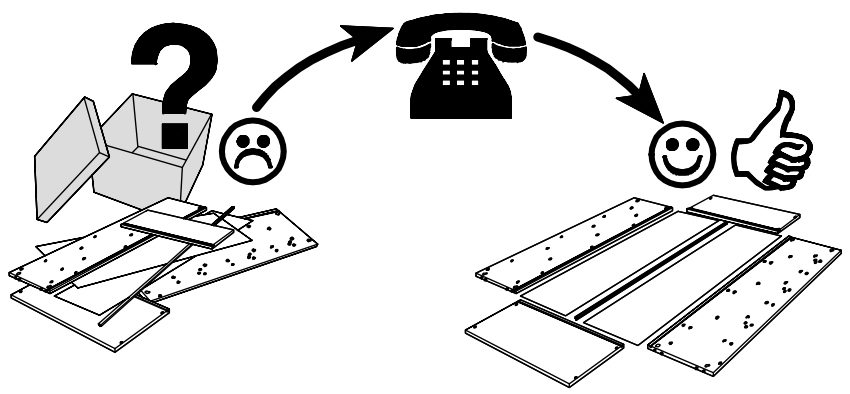
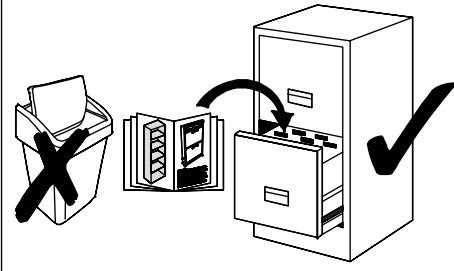

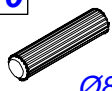

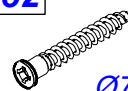

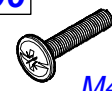
**Service • Dienstverlening • Serwis • Servis • Сервисная служба • Assistenza • Szerviz**

Name • Nom • Nome • Naam • Nazwa • Jméno •  
Názov • Név • Denumire • Isim • Название

Nr. • No. • N° • Номер • Č • Sz

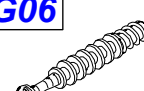
Typ • Type • Tip • Tipus • Тipo • Тип

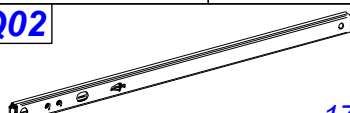
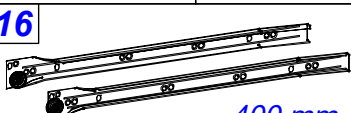

|   |  |   |  |  |   |
|---|--|---|--|--|---|
| <b>A10</b><br>22 x<br><br>Ø8 x 35        | <b>B01</b><br>18 x<br><br>Ø5,8 x 8  | <b>B52</b><br>4 x<br><br>Ø7 x 50       | <b>D02</b><br>2 x<br><br>M4 x 10          | <b>D06</b><br>3 x<br><br>M4 x 20  | <b>E17</b><br>12 x<br><br>Ø3,5 x 15  |
| <b>E22</b><br>16 x<br><br>Ø3,5 x 35     | <b>F04</b><br>1 x<br><br>4 mm      | <b>F08</b><br>1 x<br><br>45 x 20 x 16 | <b>G02</b><br>20 x<br><br>Ø15 x 11       | <b>G06</b><br>20 x<br><br>L - 34 | <b>I01</b><br>25 x<br><br>Ø1,2 x 20 |
| <b>P23</b><br>3 x<br><br>Ø30x21        | <b>Q02</b><br>2 x<br><br>17 x 430 |   | <b>Q16</b><br>2 x<br><br>400 mm, L + R |  |   |
| <b>Q17</b><br>2 x<br><br>400 mm, L + R |  |   |  |  |   |

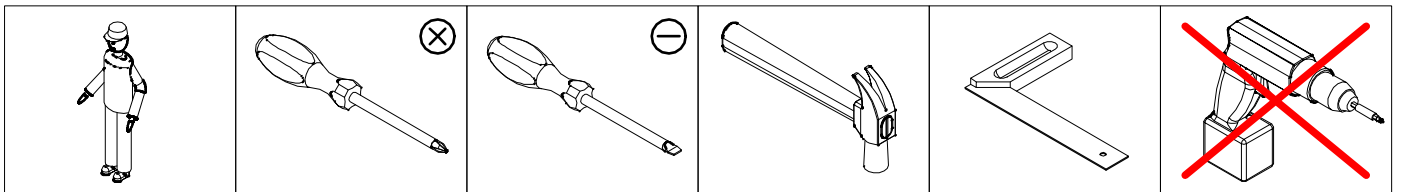

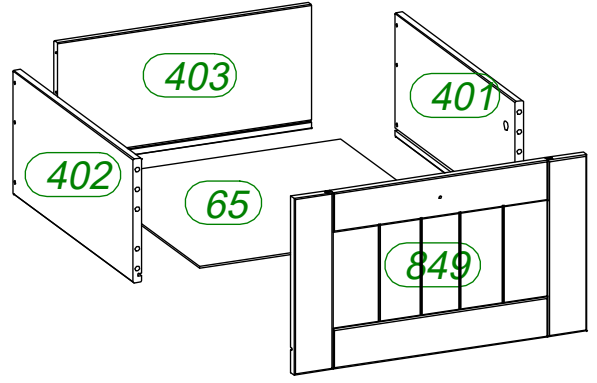
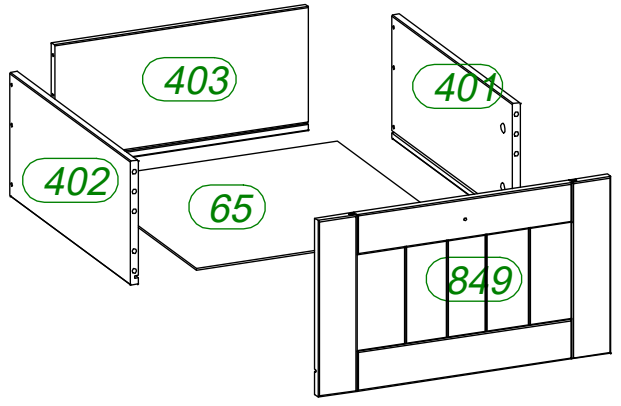
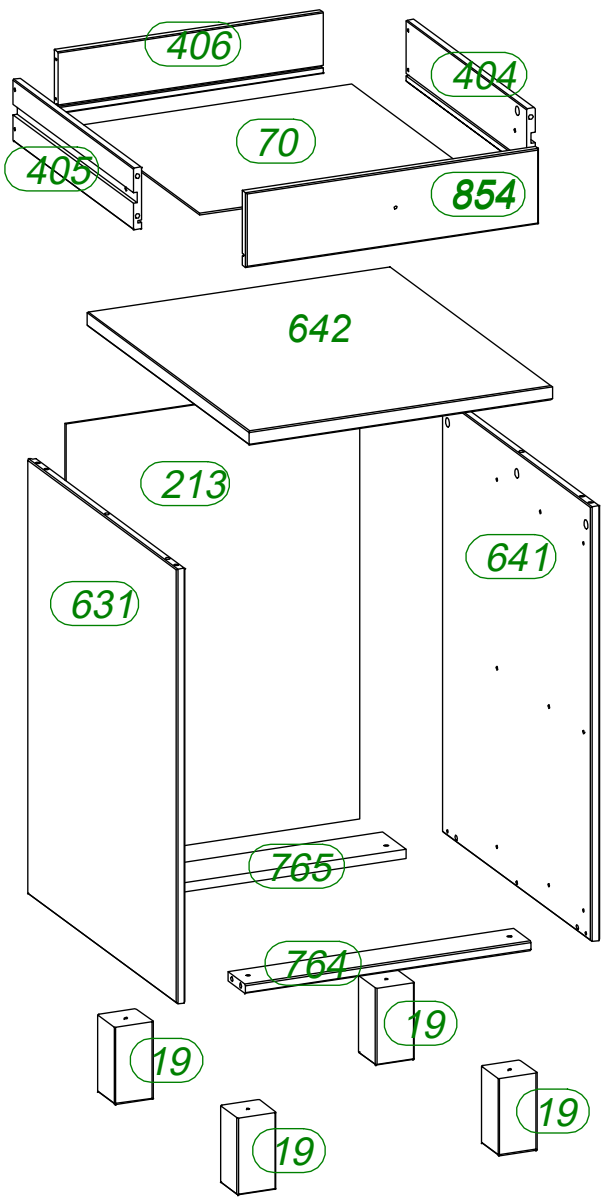



Achtung • Attention • Attenzione • Opgelet • Uwaga • Pozor • Figyelem • Atenție •  
Dikkat • Внимание

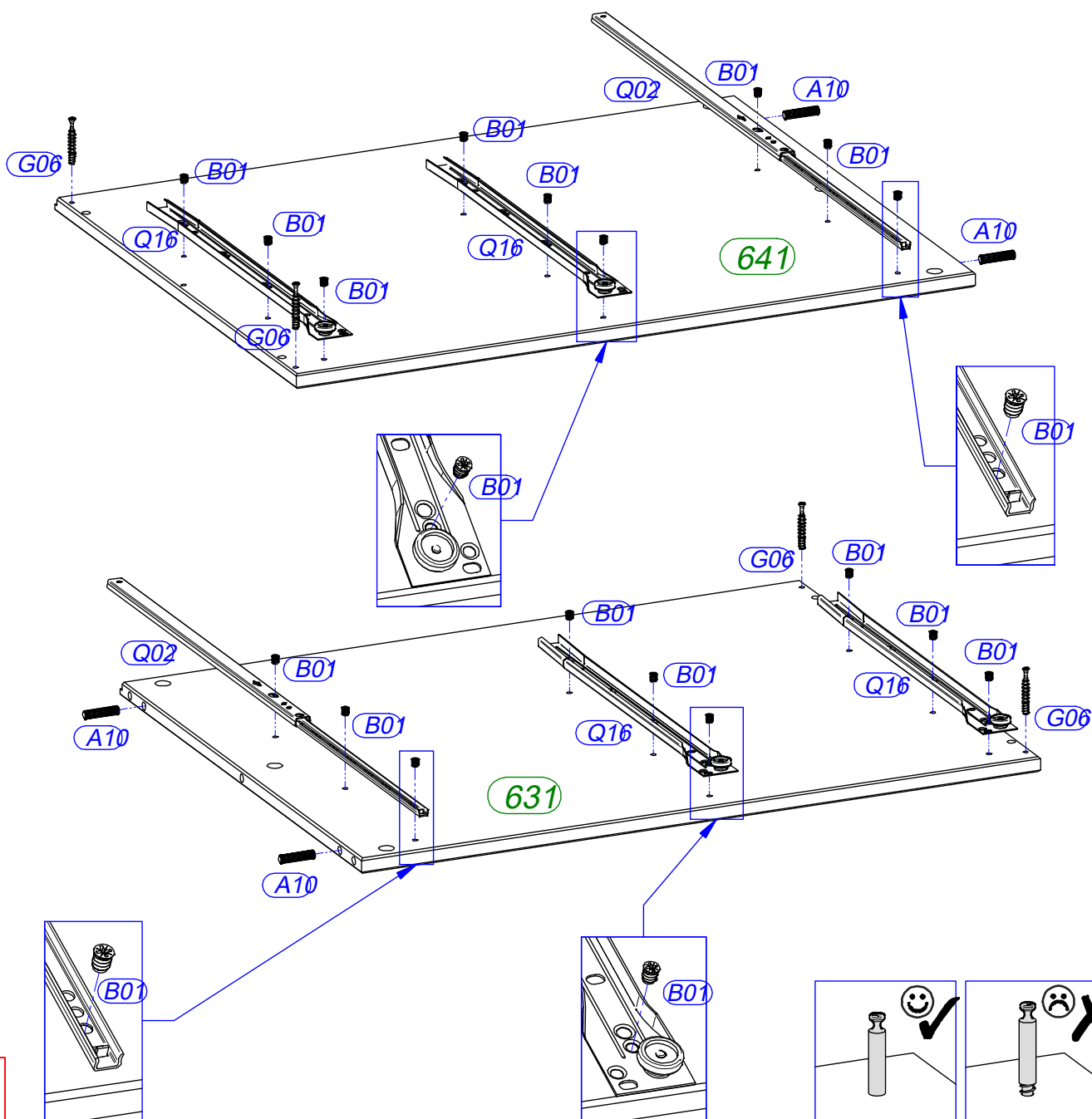
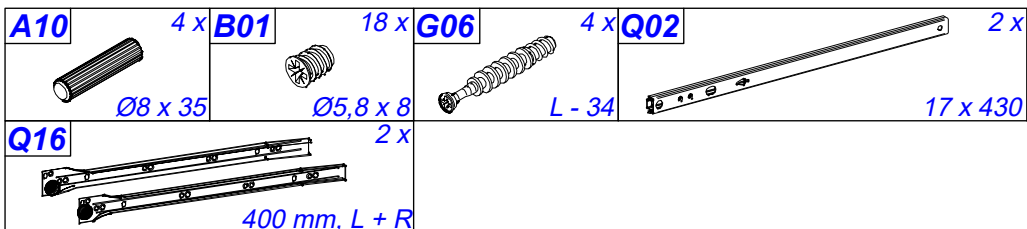
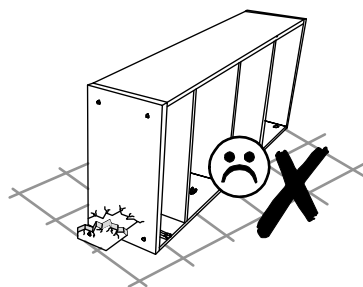
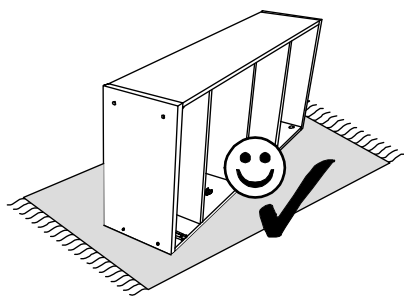

**1**

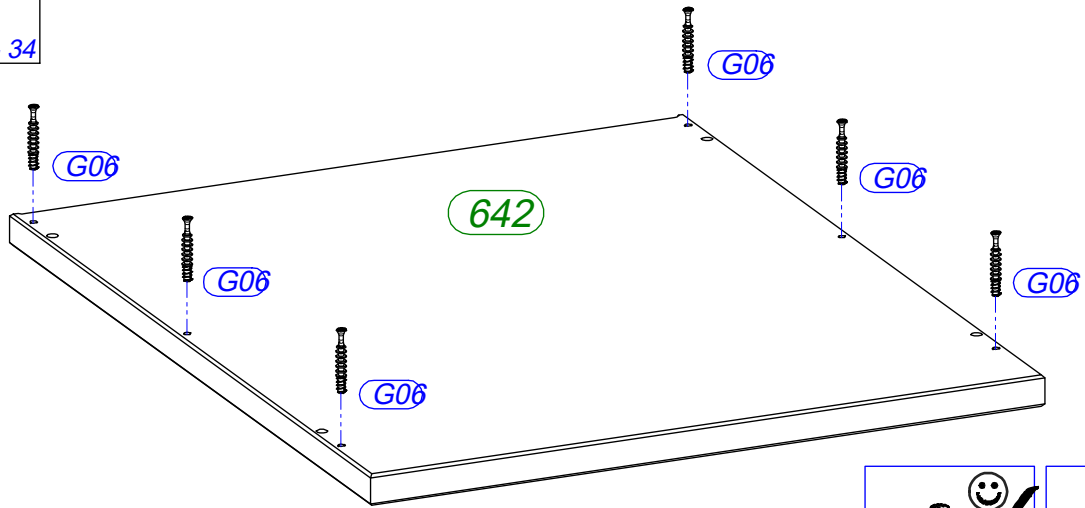
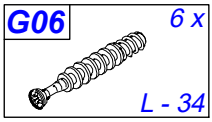

**2**

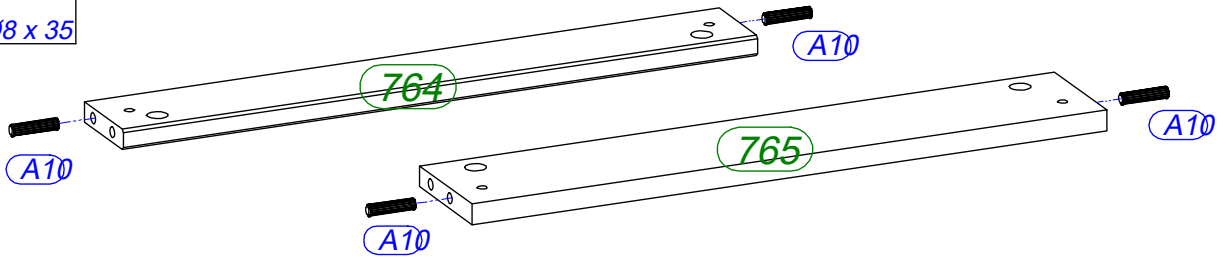
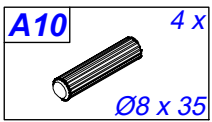
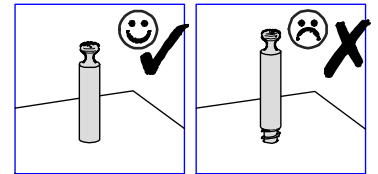

**3**

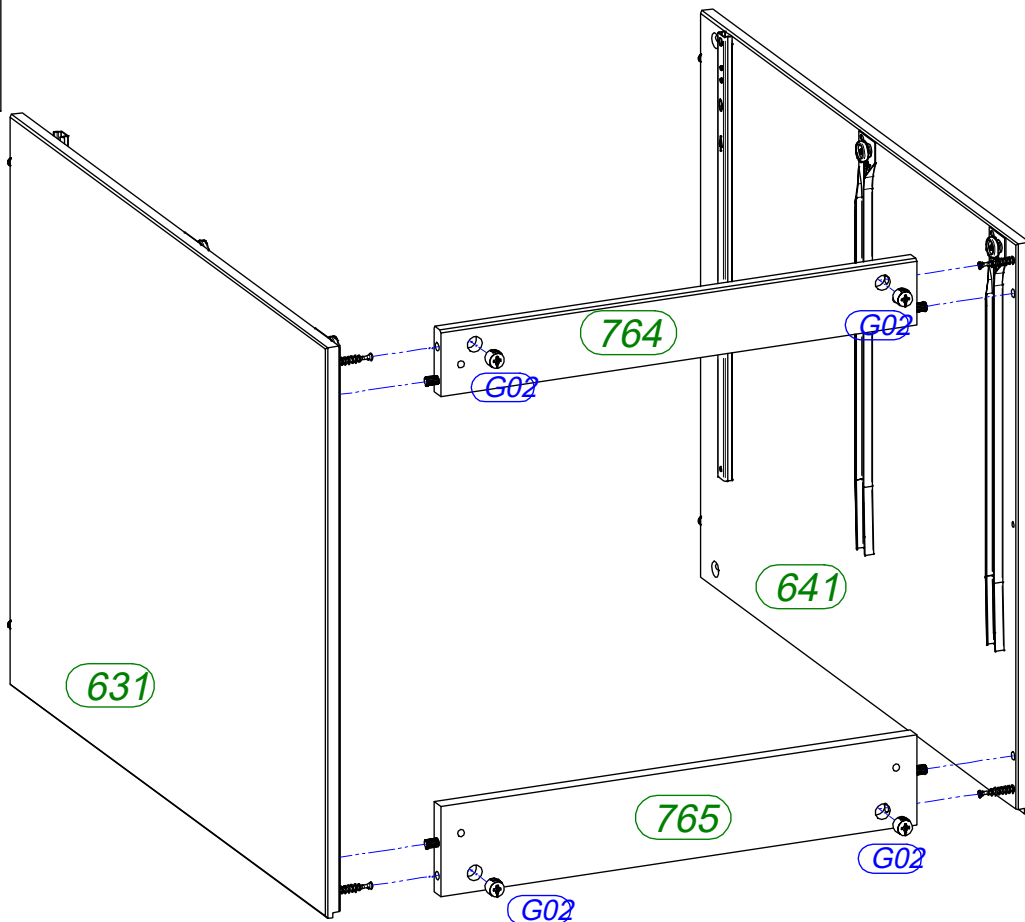
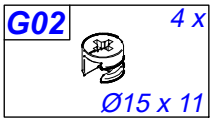

**4**

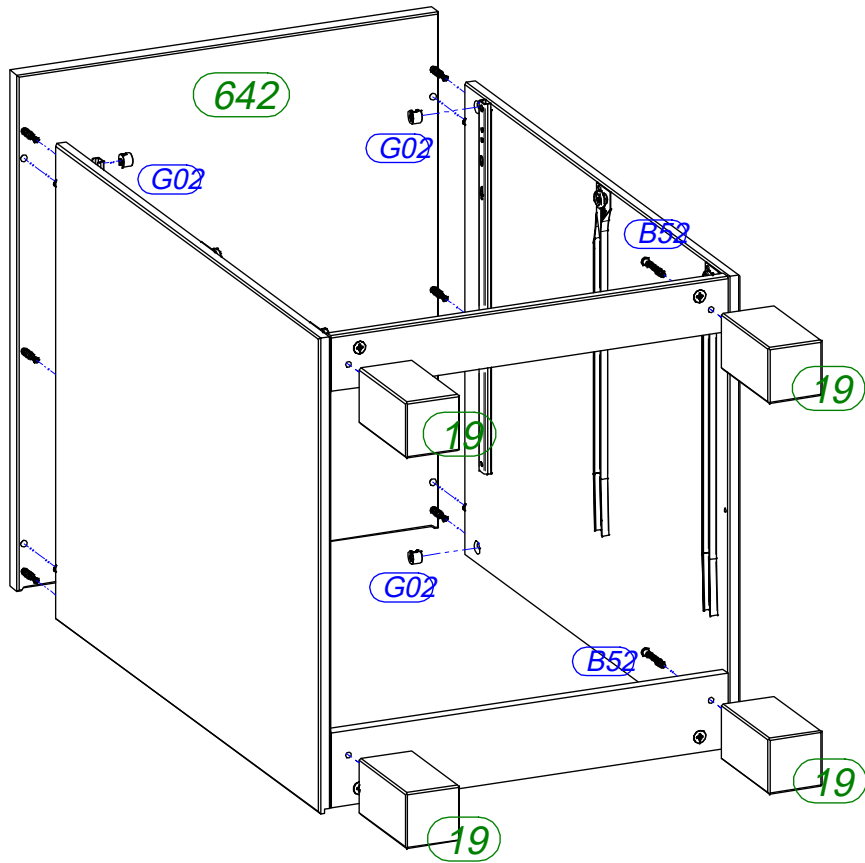
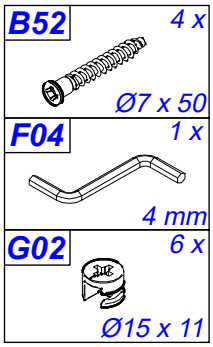

**5**

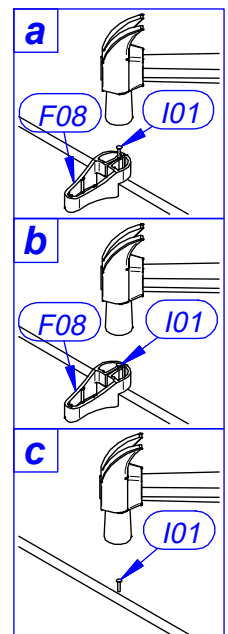
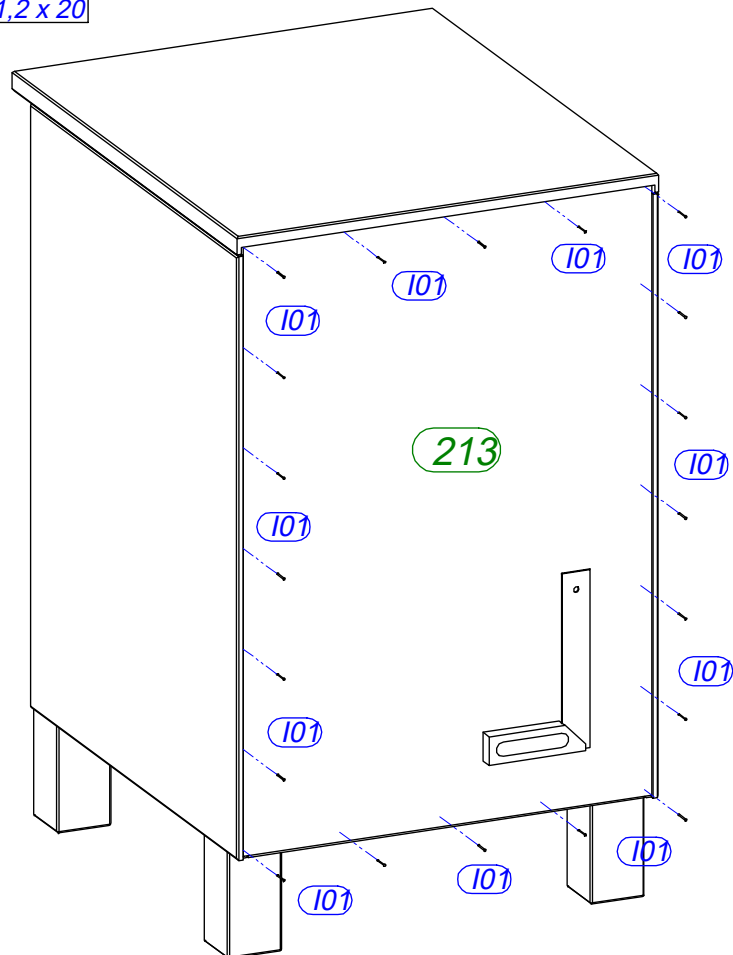
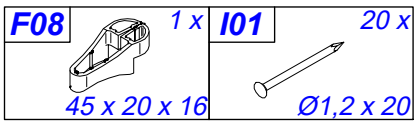

**6**

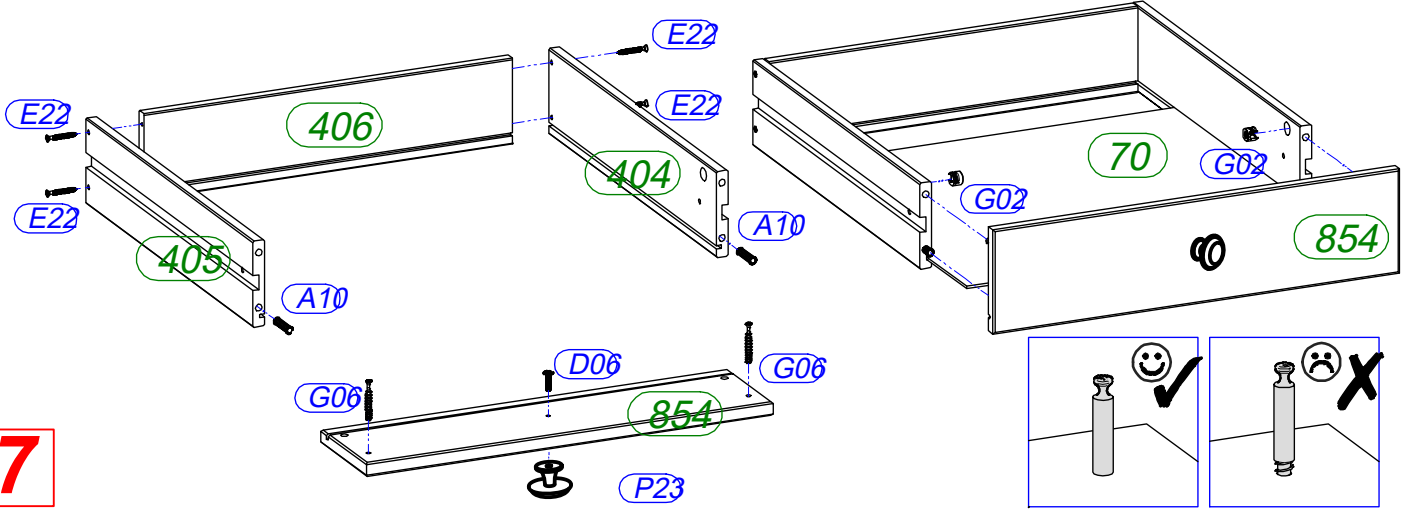
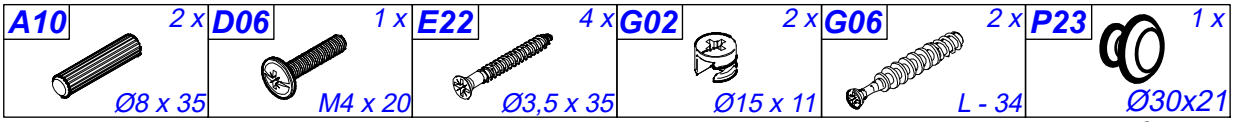

**7**

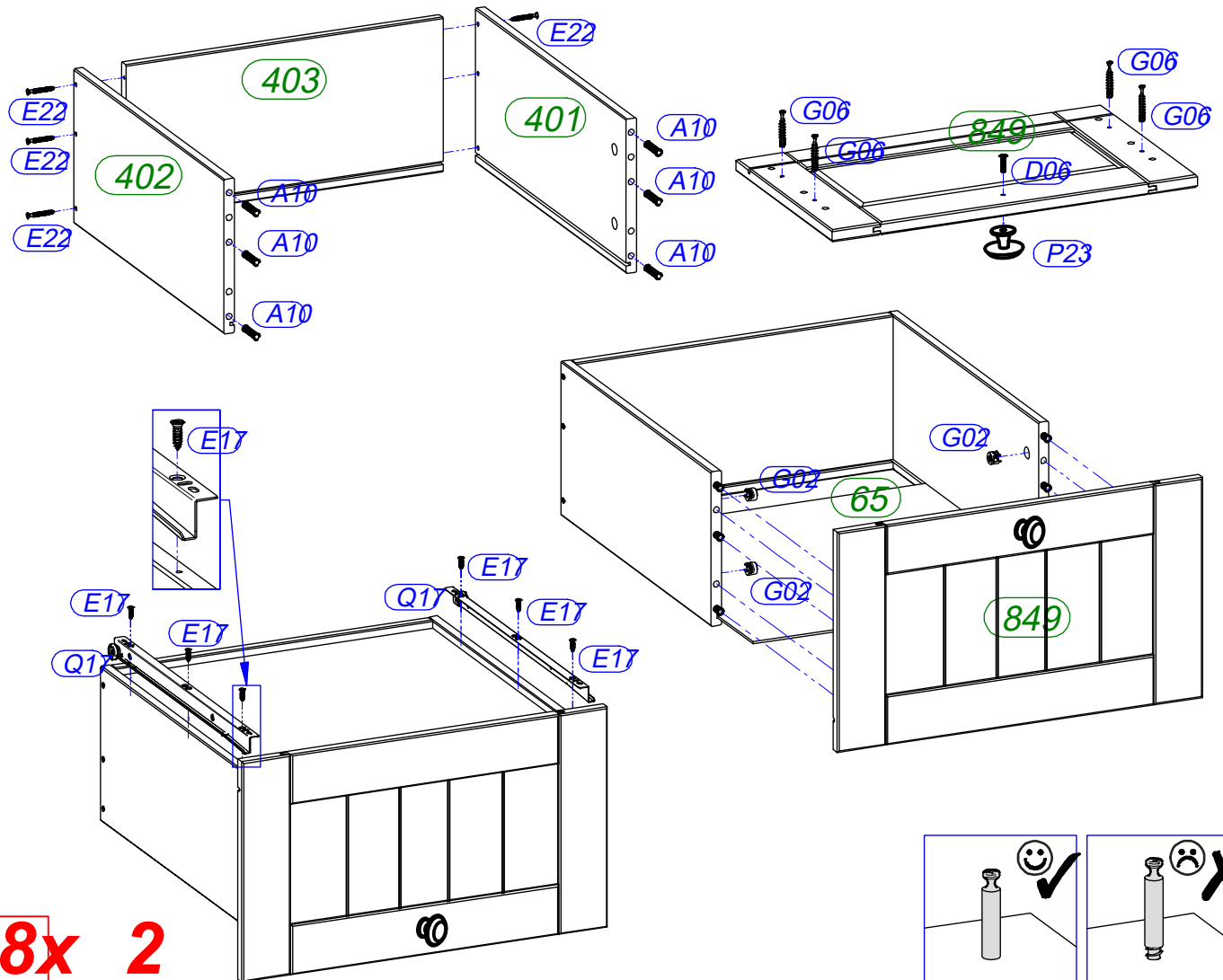
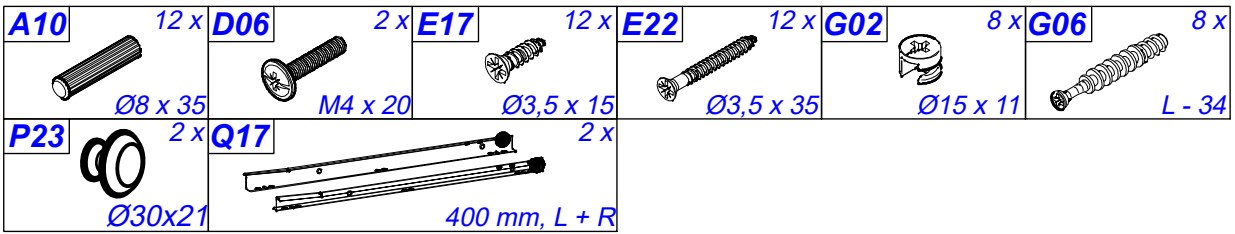

**8x 2**

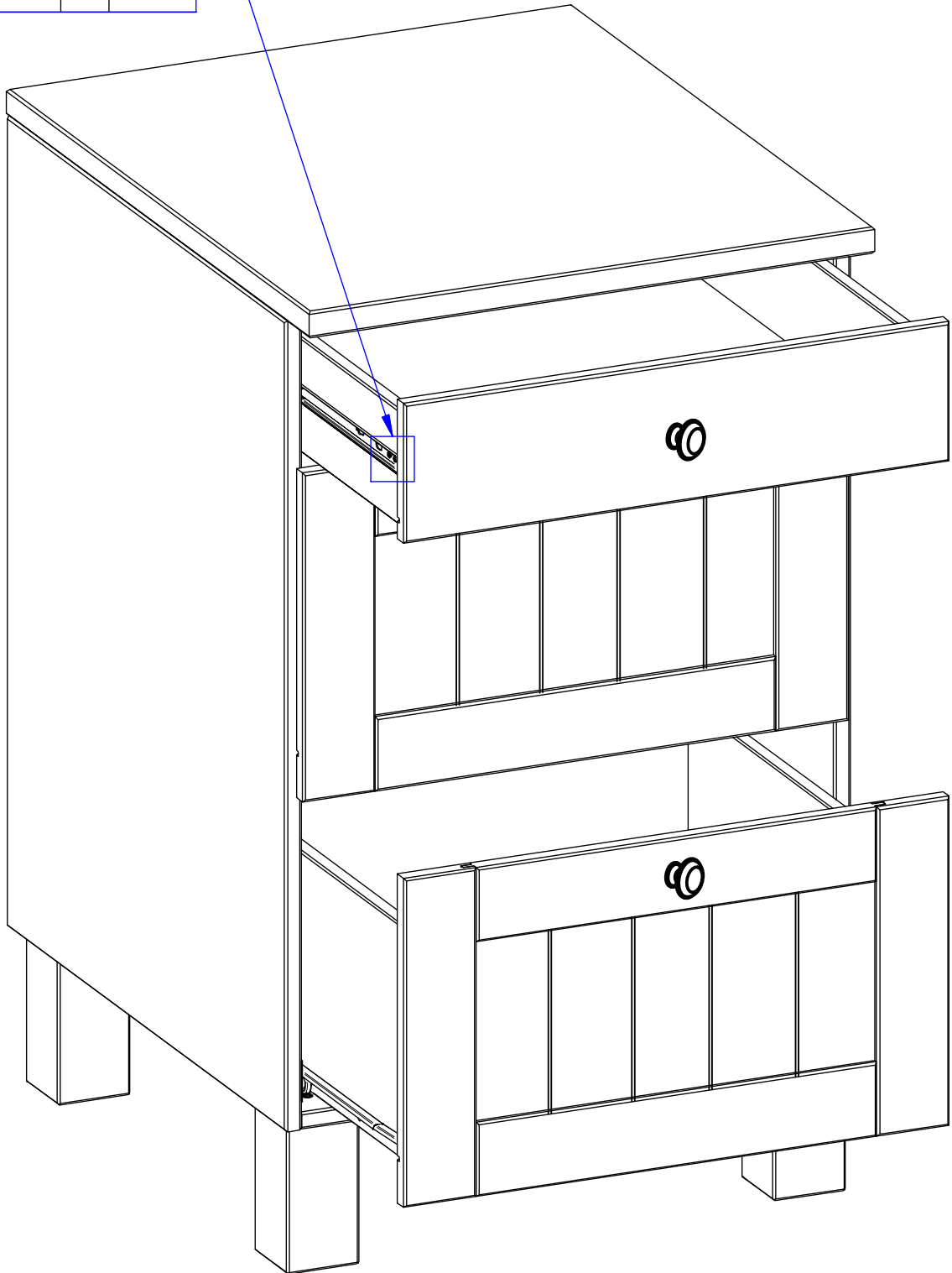
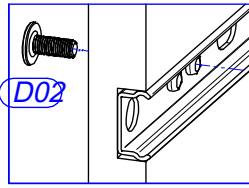
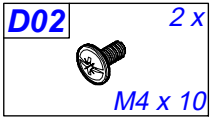



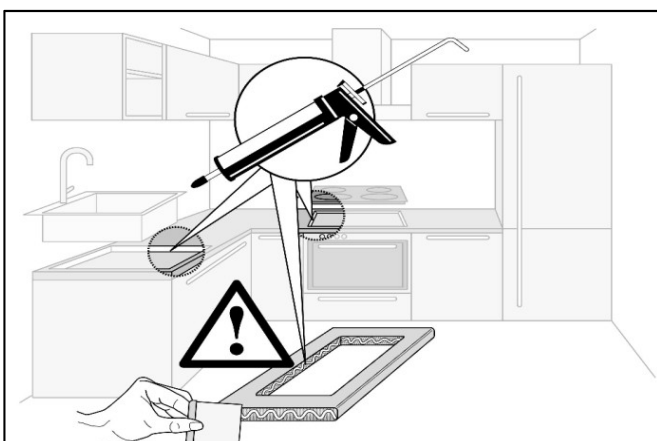
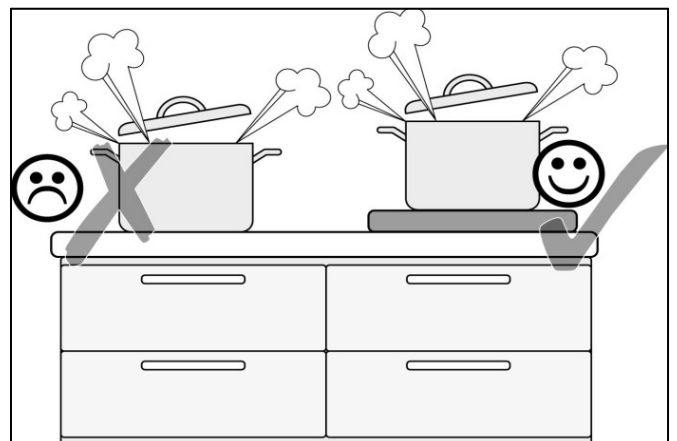
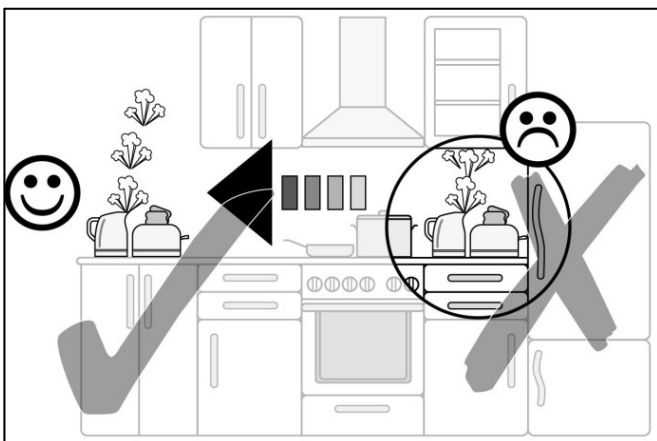
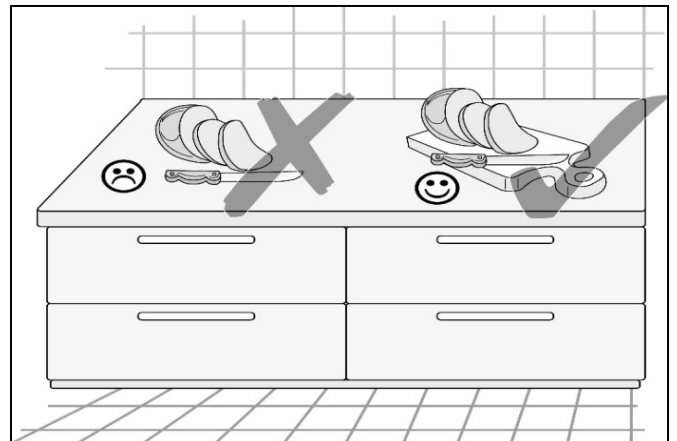
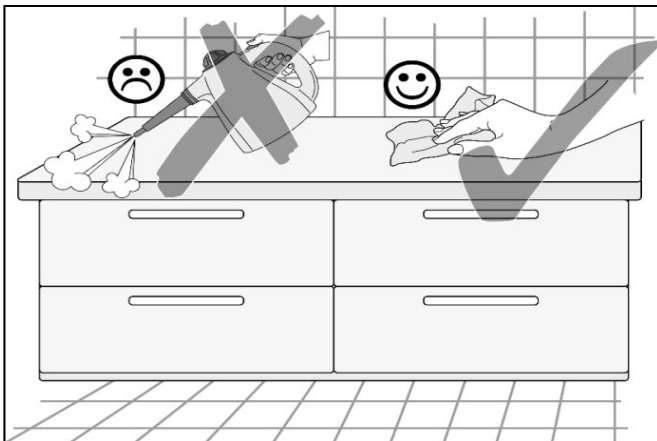
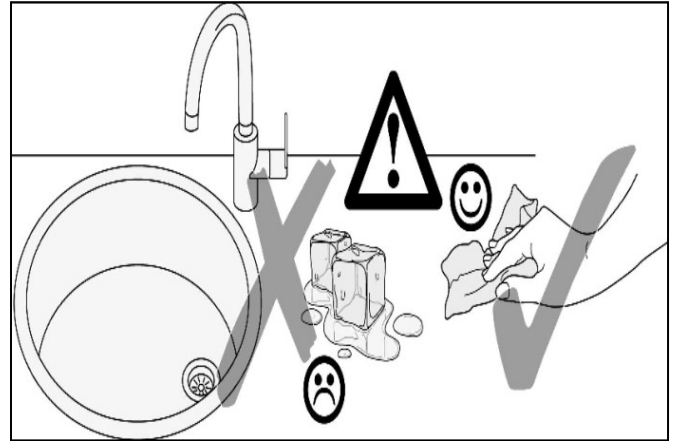
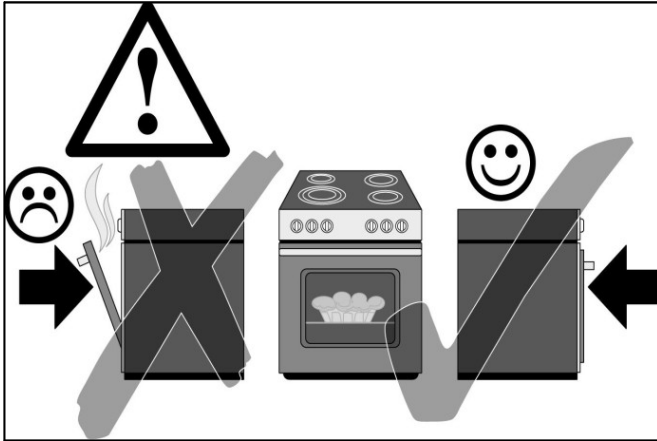

# »1363«

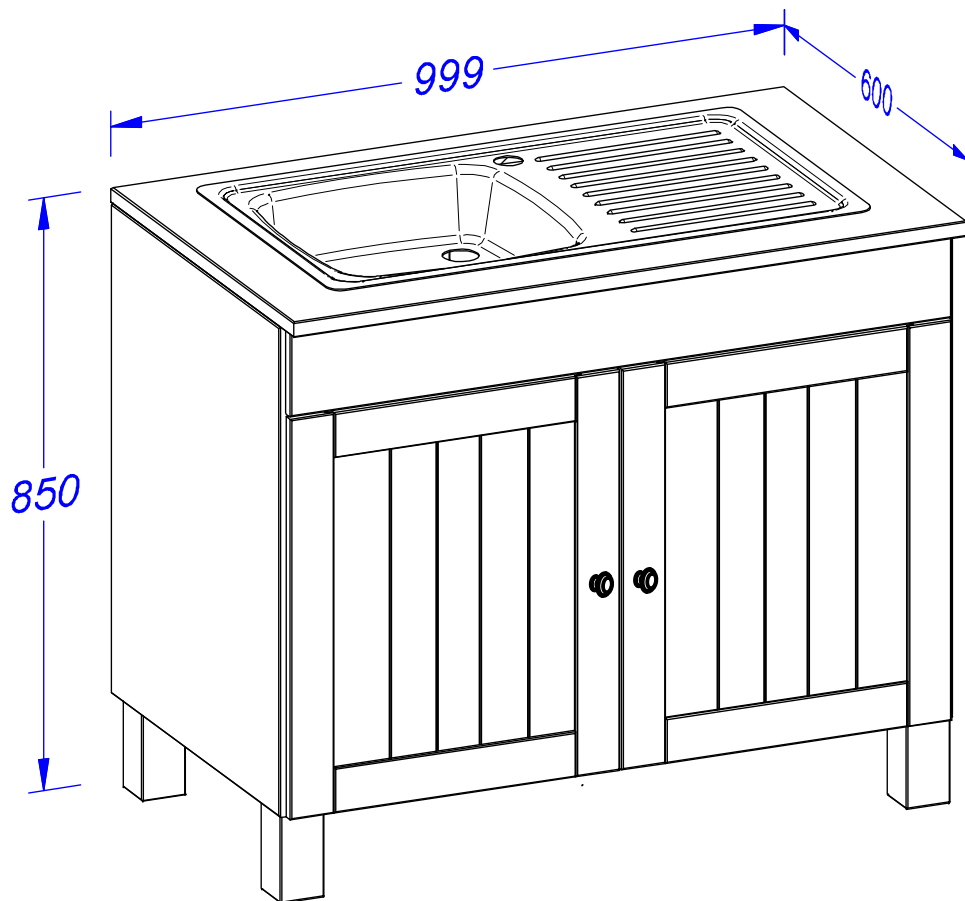

**(D)** *Montageanleitung*

**(NL)** *Handleiding voor de montage*

**(TR)** *Montaj talimatı*

**(FR)** *Notice de montage*

**(CZ)** *Montážní návod*

**(HU)** *Szerelési útmutató*

**(GB)** *Assembly instructions*

**(PL)** *Instrukcja montażu*

**(RU)** *Инструкция по монтажу*

**(IT)** *Istruzioni di montaggio*

**(SK)** *Návod na montáž*

**(RO)** *Instrucțiuni de montaj*









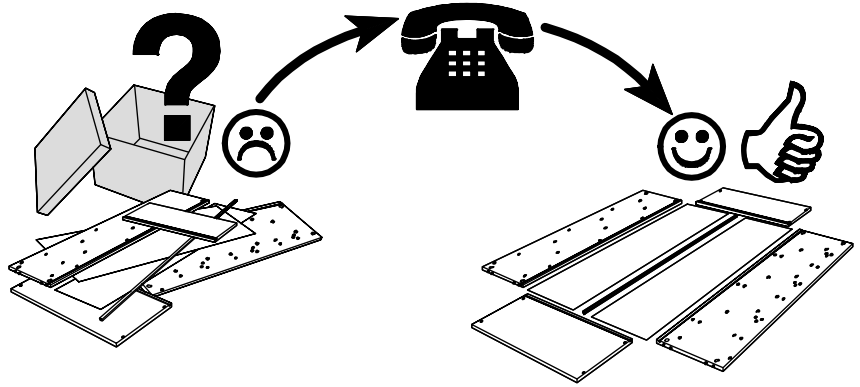
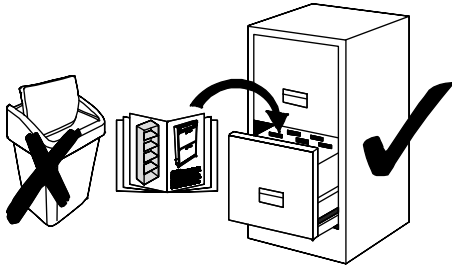

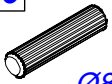
**Service • Dienstverlening • Serwis • Servis • Сервисная служба • Assistenza • Szerviz**

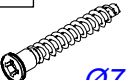
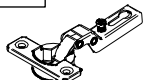
Name • Nom • Nome • Naam • Nazwa • Jméno •  
Názov • Név • Denumire • Isim • Название

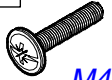
Nr. • No. • N° • Номер • Č • Sz

Typ • Type • Tip • Tipus • Тipo • Тип

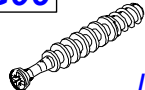
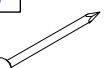

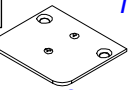

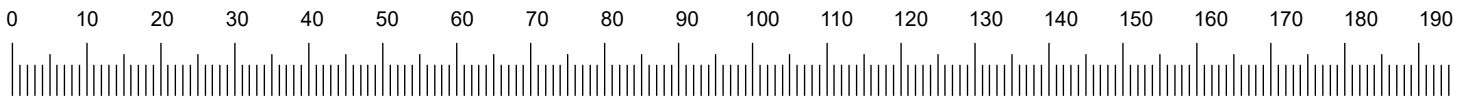
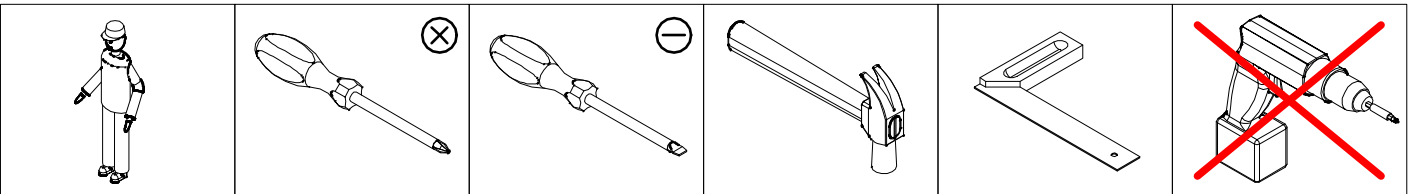

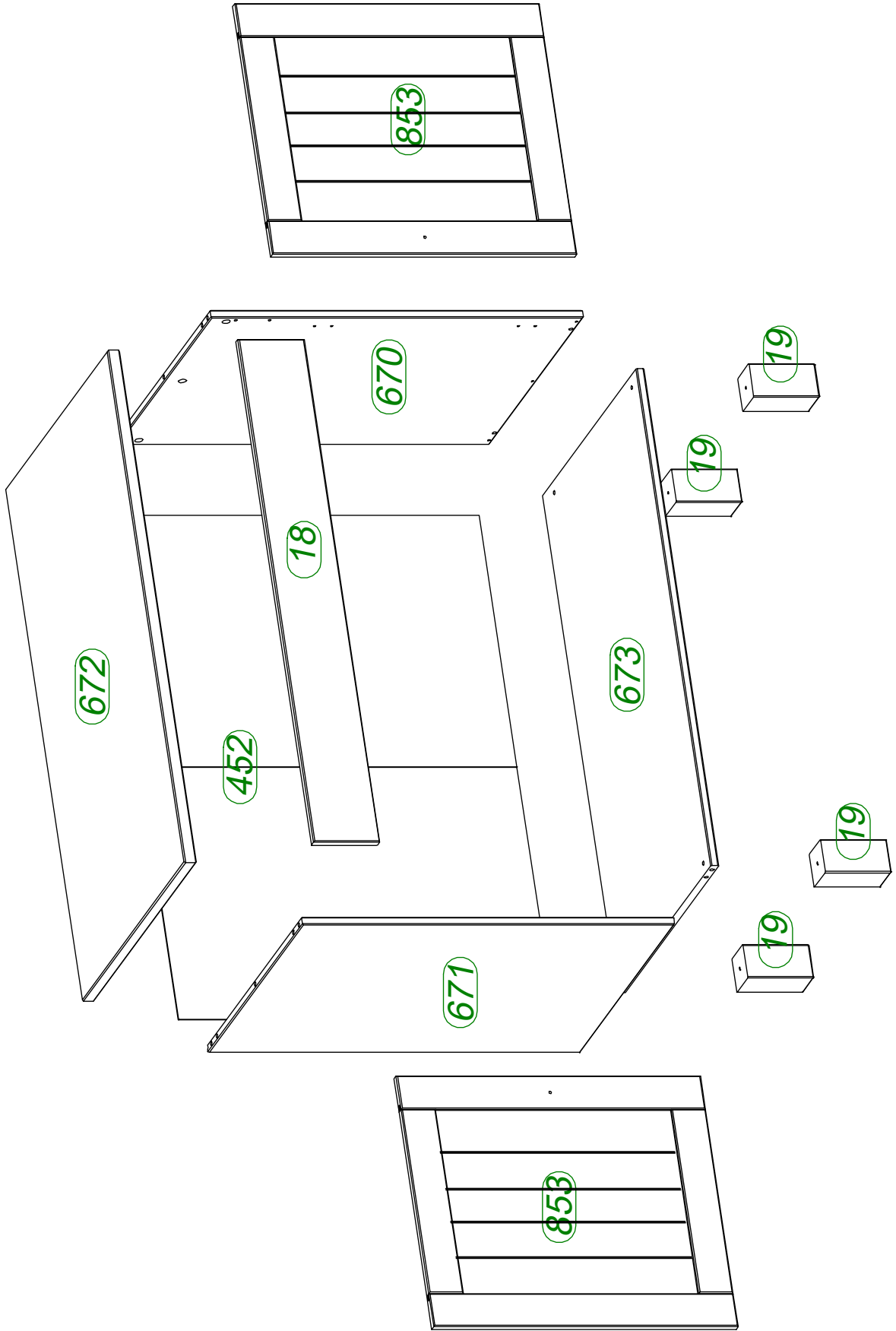
|  |   |   |  |  |   |
|--|---|---|--|--|---|
| <b>A10</b><br>8 x<br><br>Ø8 x 35              | <b>B06</b><br>8 x<br><br>Ø6,3 x 12 | <b>B52</b><br>4 x<br><br>Ø7 x 50       | <b>C02</b><br>4 x<br><br>fk.9       | <b>C20</b><br>4 x<br><br>2 mm     | <b>D06</b><br>2x<br><br>M4 x 20      |
| <b>E17</b><br>10 x<br><br>Ø3,5 x 15          | <b>F04</b><br>1 x<br><br>4 mm     | <b>F08</b><br>1 x<br><br>45 x 20 x 16 | <b>G02</b><br>12 x<br><br>Ø15 x 11 | <b>G06</b><br>12 x<br><br>L - 34 | <b>I01</b><br>50 x<br><br>Ø1,2 x 20 |
| <b>K01</b><br>4 x<br><br>20 x 20 x 16 / 6,5 | <b>P23</b><br>2 x<br><br>Ø30x21  | <b>R19</b><br>1 x<br><br>35 x 40     |  |  |   |

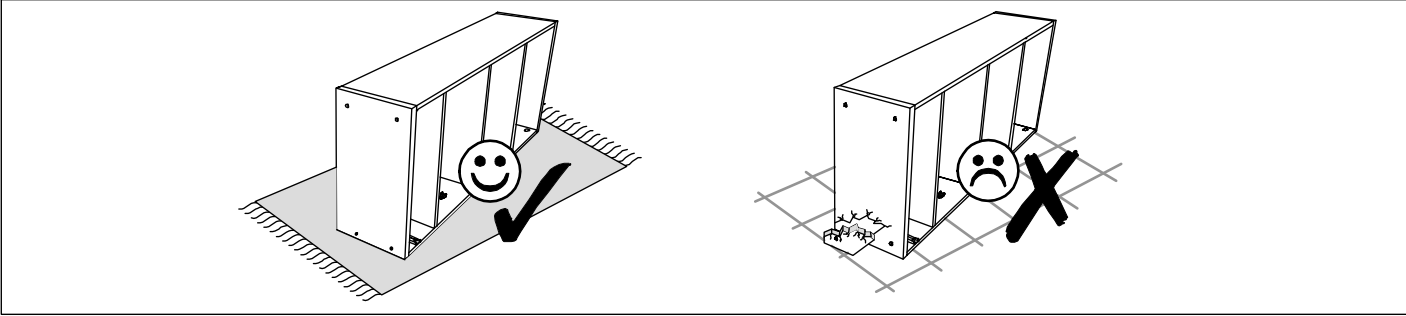



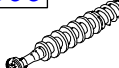

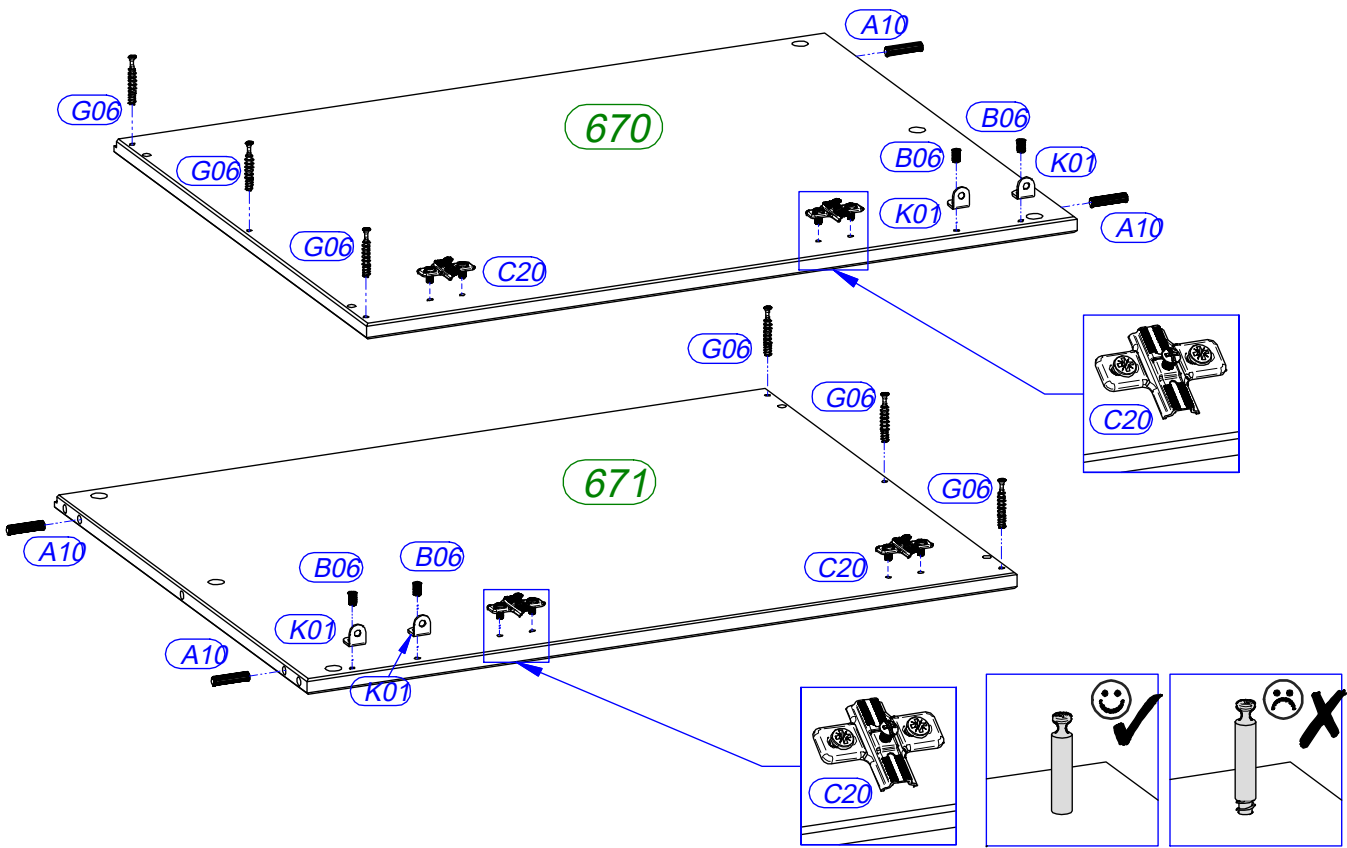

|   |     |   |     |   |     |   |     |   |     |
|---|-----|---|-----|---|-----|---|-----|---|-----|
| <b>A10</b>  | 4 x | <b>B06</b>  | 4 x | <b>C20</b>  | 4 x | <b>G06</b>  | 6 x | <b>K01</b>  | 4 x |
|  |     |  |     |  |     |  |     |  |     |
| $\varnothing 8 \times 35$   |     | $\varnothing 6,3 \times 12$   |     | 2 mm  |     | L - 34  |     | 20 x 20 x 16 / 6,5  |     |



|   |     |   |     |   |     |
|---|-----|---|-----|---|-----|
| <b>A10</b>  | 4 x | <b>E17</b>  | 2 x | <b>R19</b>  | 1 x |
|  |     |  |     |  |     |
| $\varnothing 8 \times 35$   |     | $\varnothing 3,5 \times 15$   |     | 35 x 40   |     |

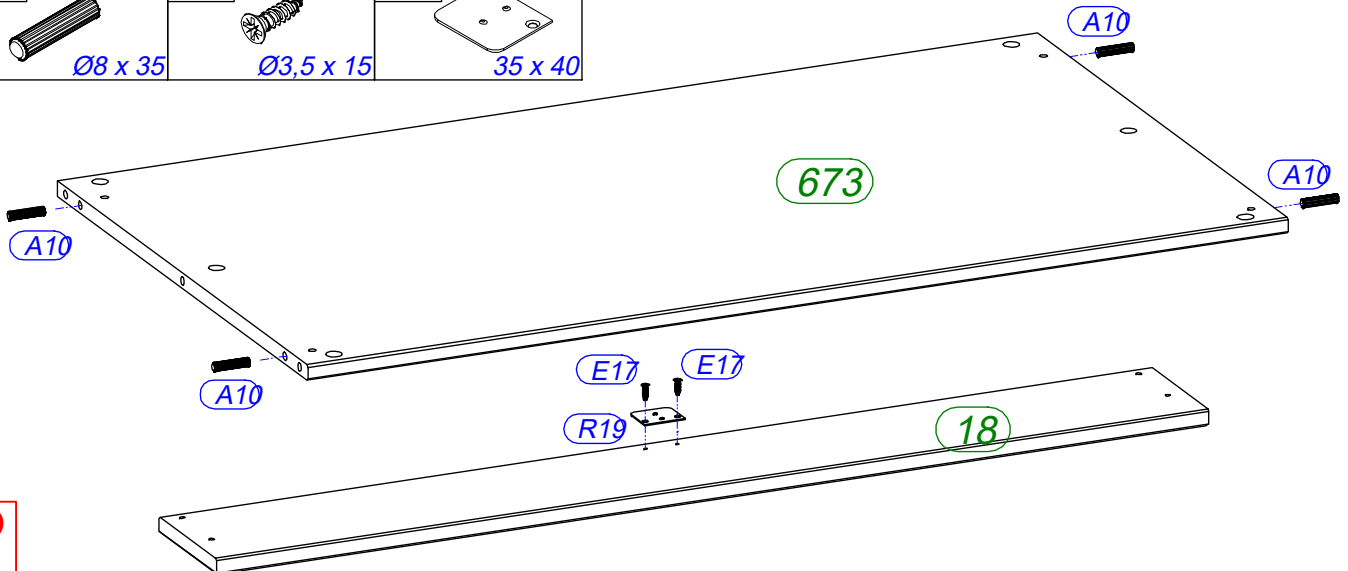

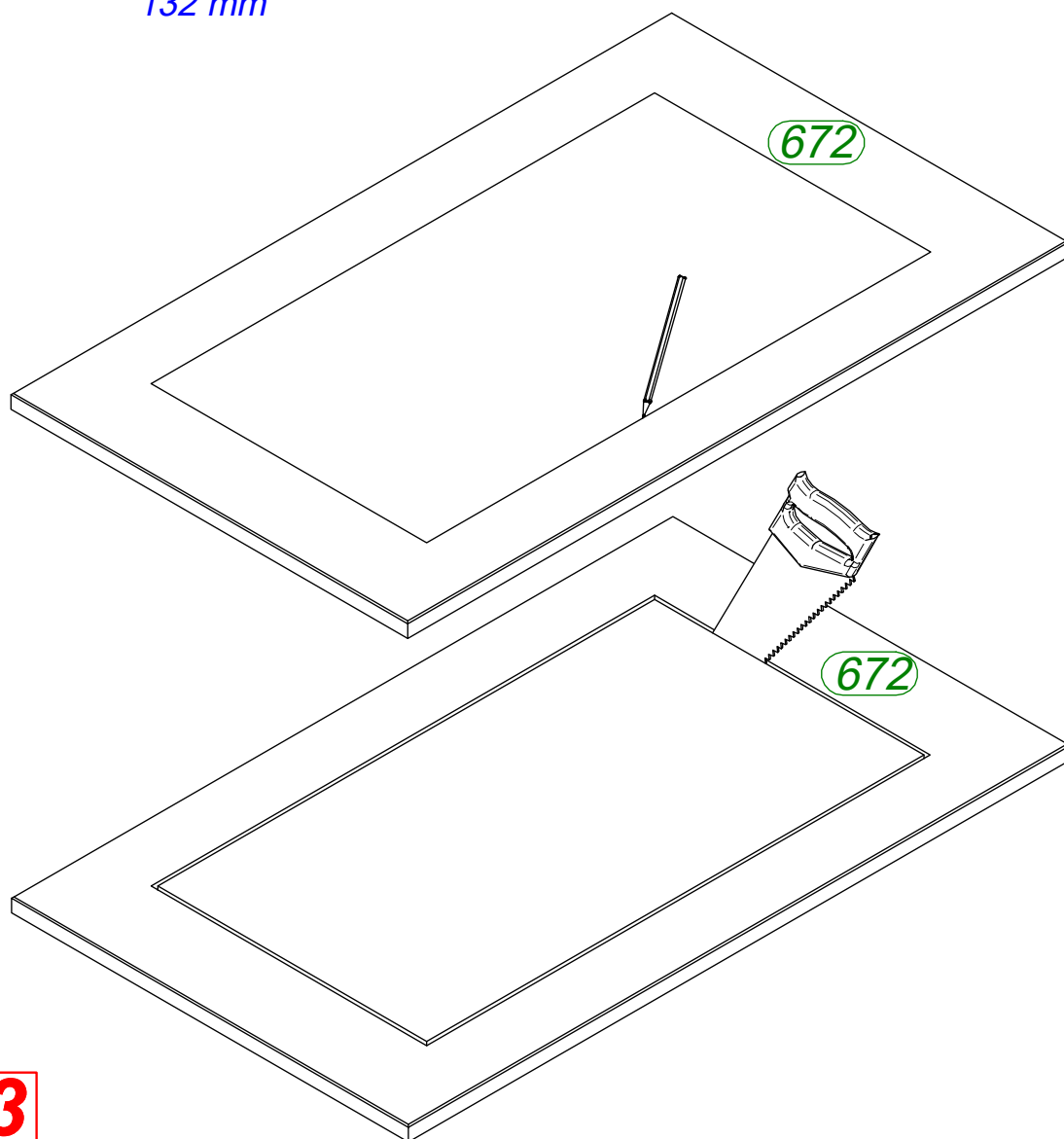
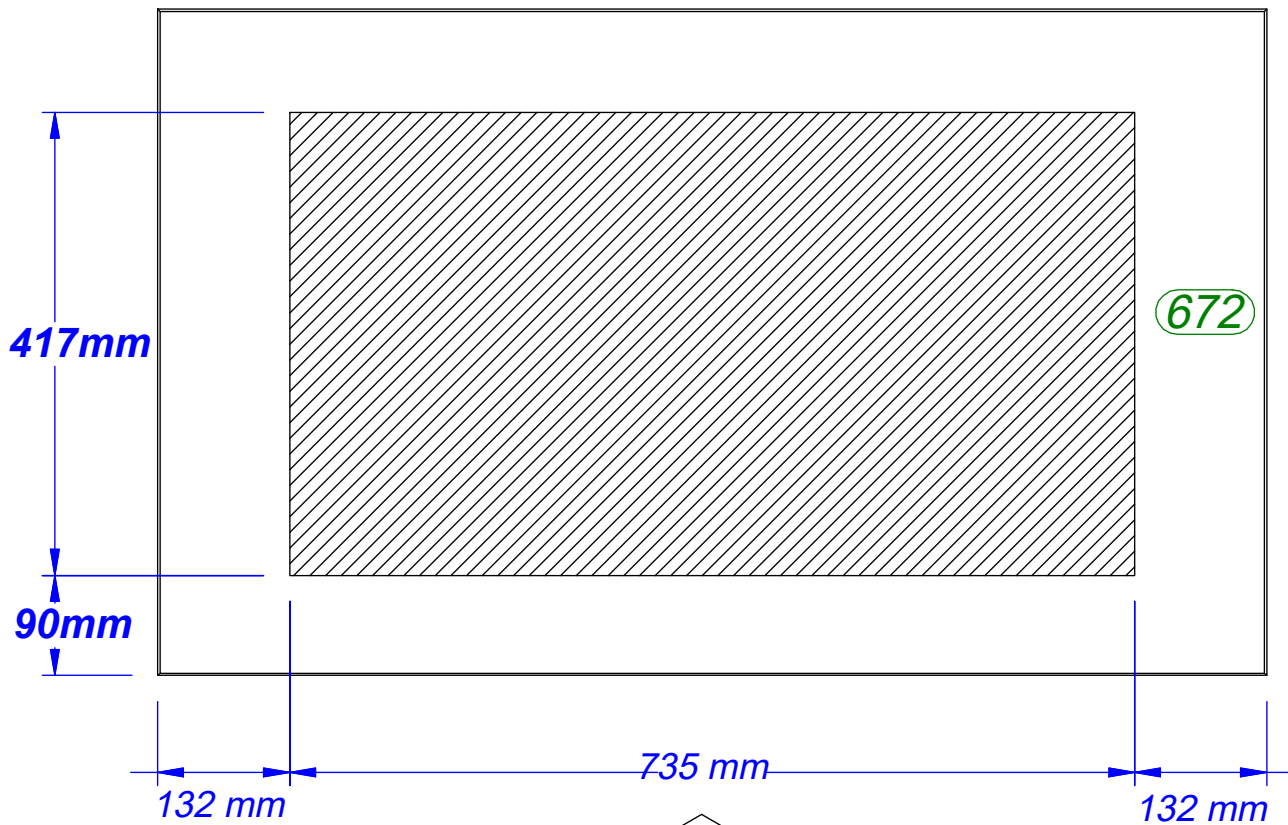

**3**

**Achtung • Attention • Attenzione • Opgelet • Uwaga • Pozor • Figyelem • Atenție •  
Dikkat • Вниманіе**

|             |  |
|-------------|--|
| <b>(D)</b>  | Bitte montieren Sie das Spülbecken auf der Topplatte laut Aufbauanleitung des Spülbeckens als erstes.      |
| <b>(GB)</b> | Please mount the basin onto the top plate first, as described in the manual.                               |
| <b>(NL)</b> | Plaats de bak eerst op de bovenste plaat zoals beschreven in de handleiding.                               |
| <b>(PL)</b> | W pierwszej kolejności zamontować zlewozmywak na górnym blacie zgodnie z instrukcją montażu zlewozmywaka.  |
| <b>(TR)</b> | İlk önce, kullanım kılavuzunda tanımladığı üzere evyenin en üst tabaka üzerinde kurulumunu gerçekleştirin. |
| <b>(RU)</b> | Сначала установите резервуар на верхнюю плиту как описано в руководстве.                                   |
| <b>(FR)</b> | S'il vous plaît installer le bassin sur la plaque du haut d'abord, comme décrit dans le manuel.            |
| <b>(IT)</b> | Si prega di montare il bacino sulla piastra superiore, come descritto nel manuale.                         |
| <b>(CZ)</b> | Prosím, držák pánve na horní desce první, jak je popsáno v manuálu.  |
| <b>(SK)</b> | Prosím, držiak panvice na hornej doske prvé, ako je popísané v manuáli.                                    |
| <b>(HU)</b> | Kérjük, szerelje fel a medencét rá a felső lemez első, ahogy az a kézikönyvben.                            |
| <b>(RO)</b> | Vă rugăm să mount bazinul pe placa de top în primul rând, așa cum este descris în manual.                  |

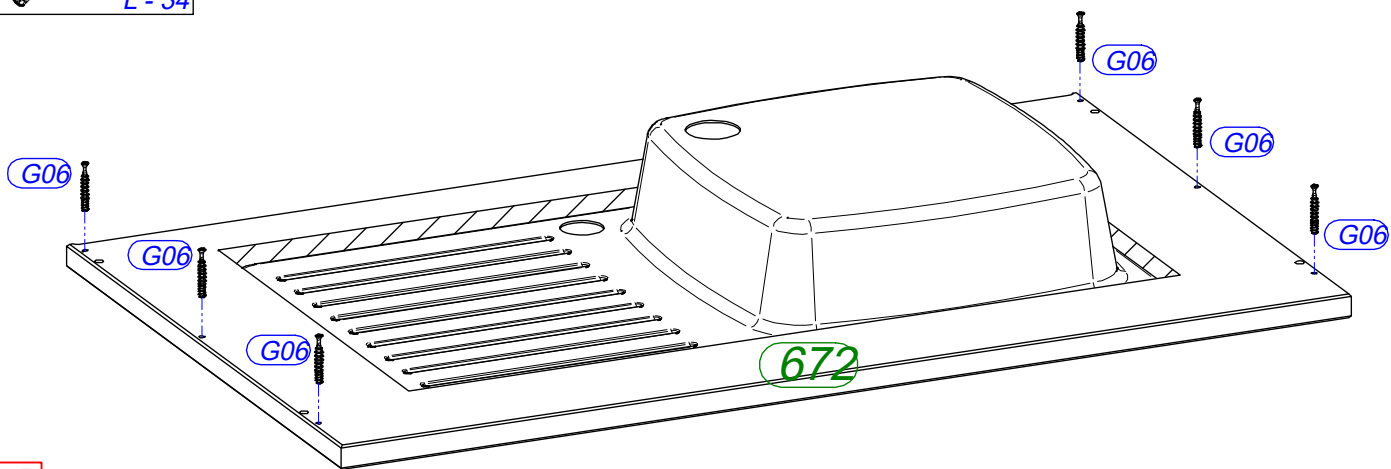
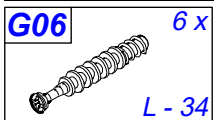

**4**

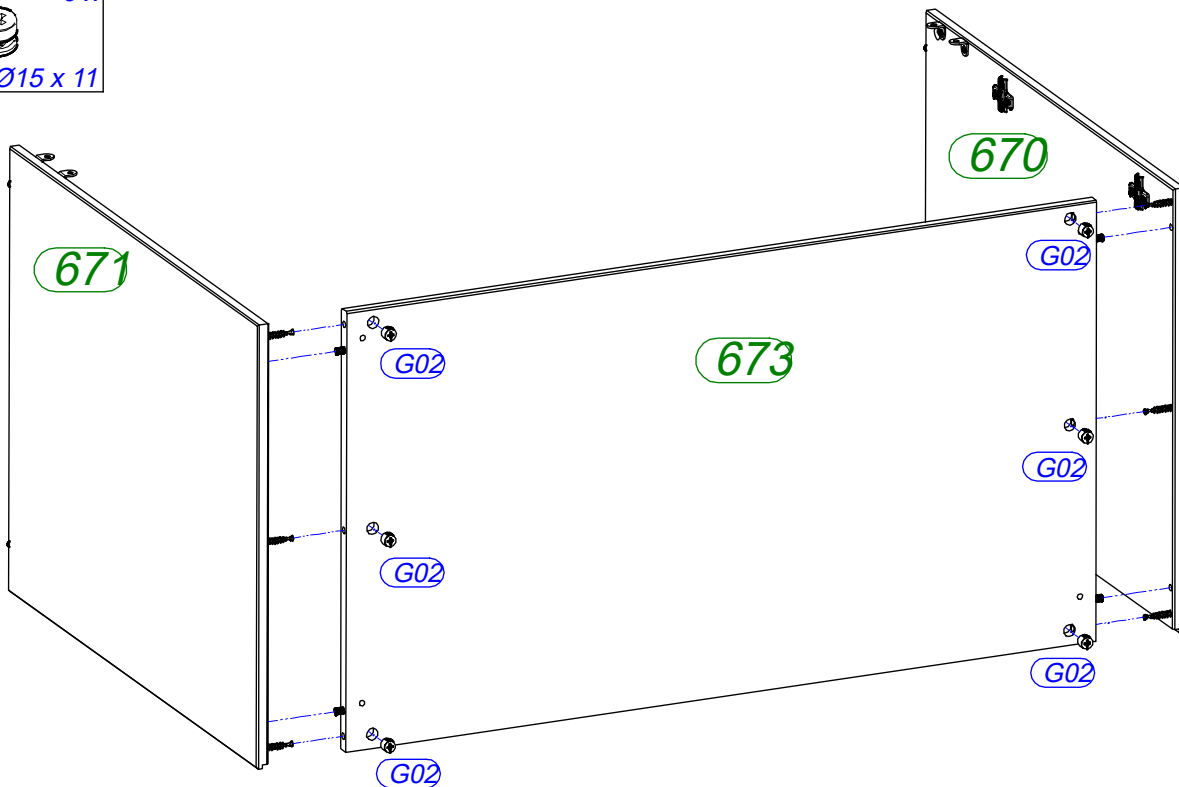
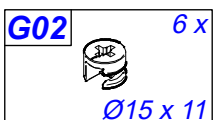

**5**

**G02** 6 x  
  
 Ø15 x 11

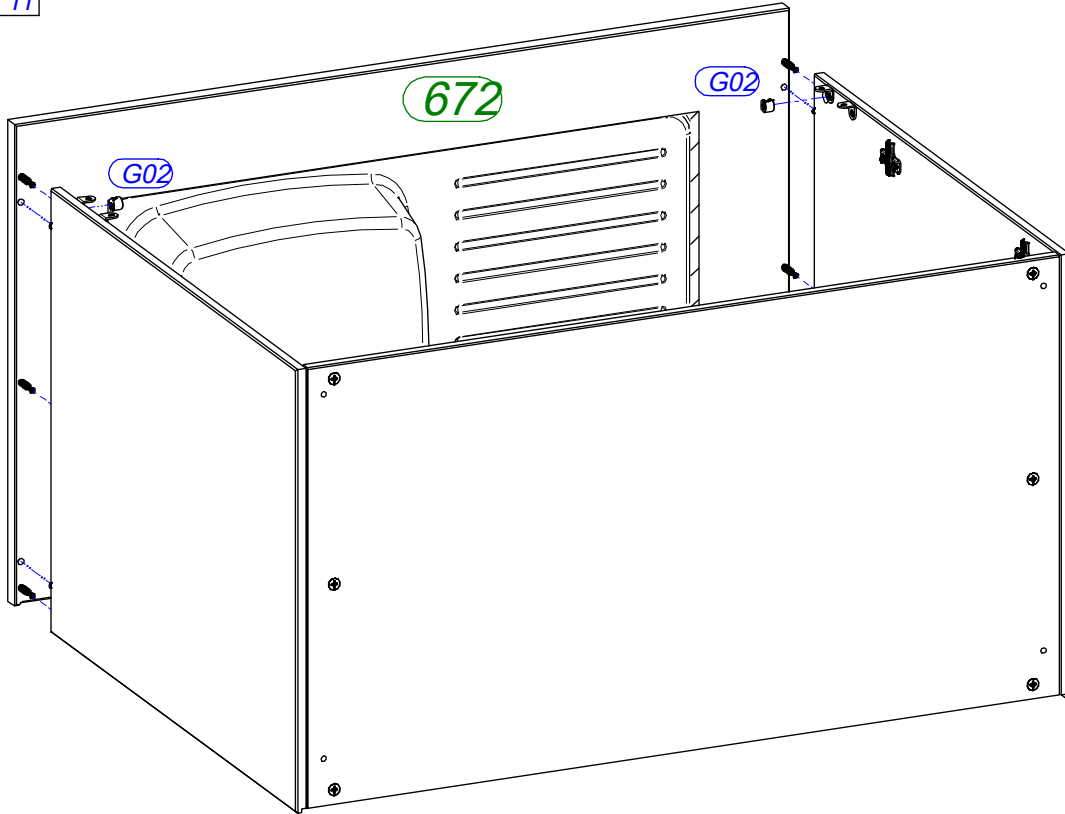

**6**

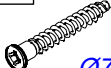
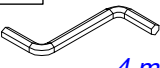
**B06** 4 x **B52** 4 x **F04** 1 x  
 Ø6,3 x 12  Ø7 x 50  4 mm

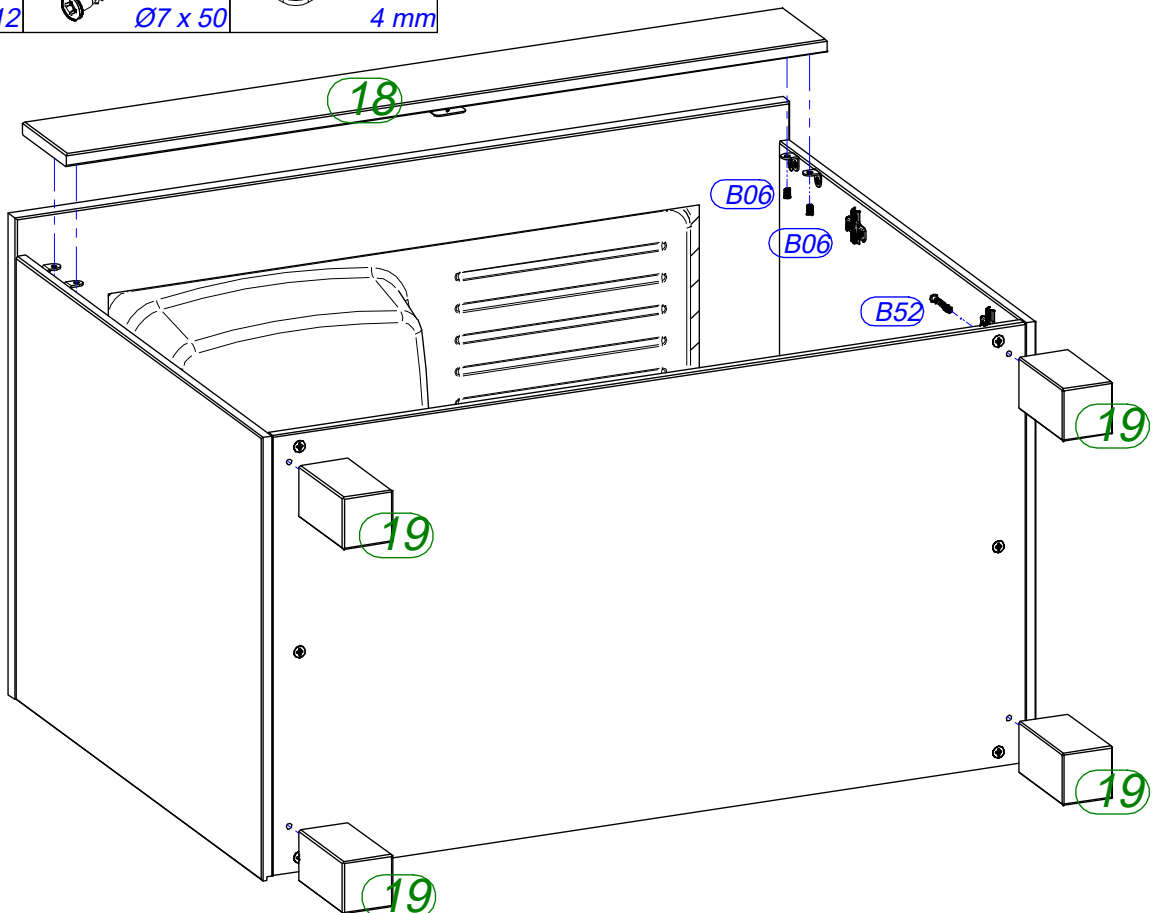

**7**



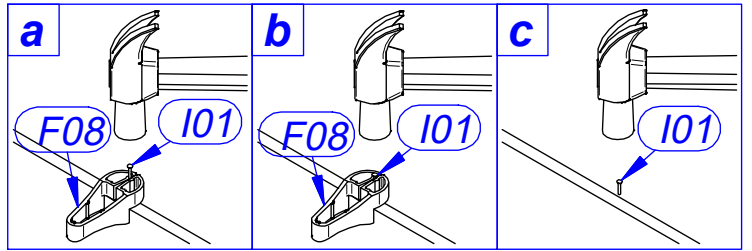
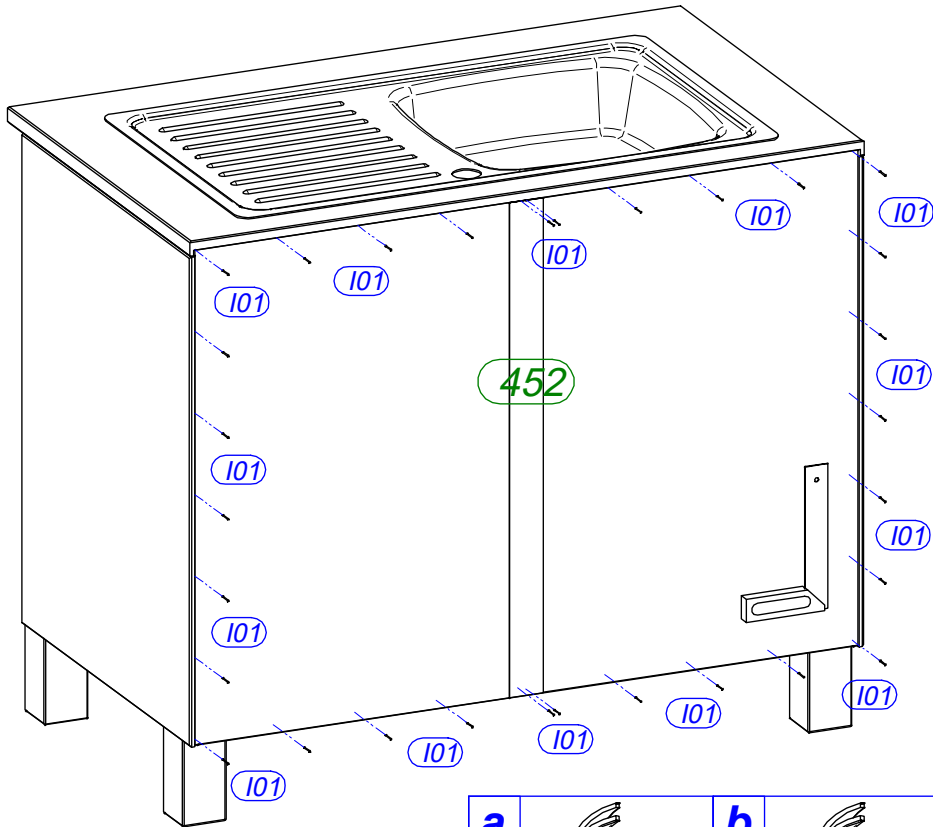
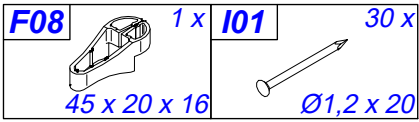

**8**

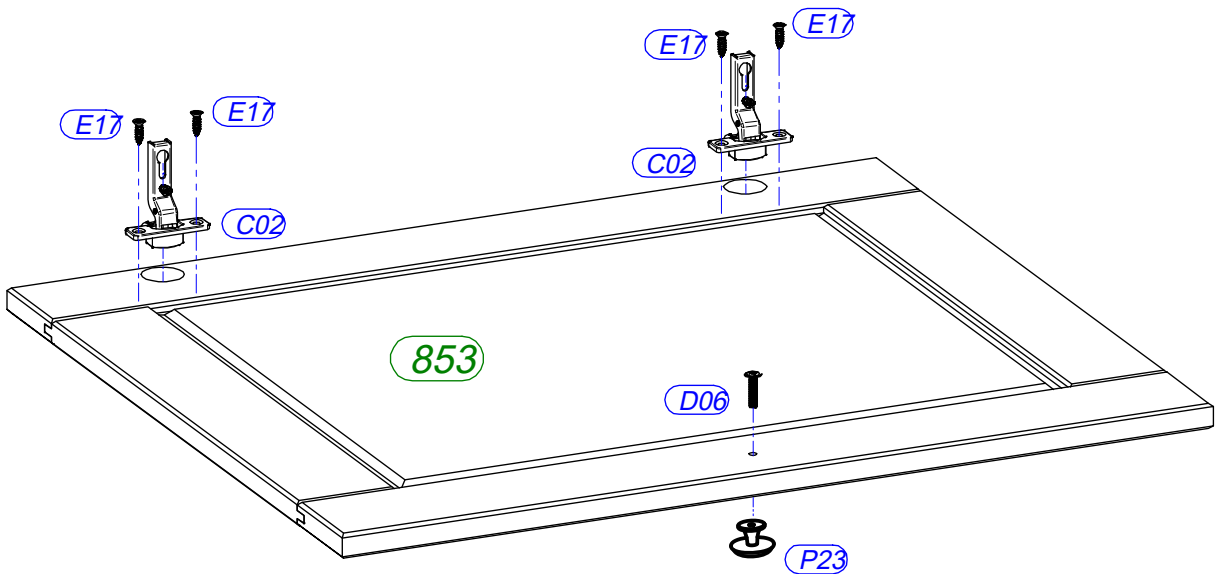
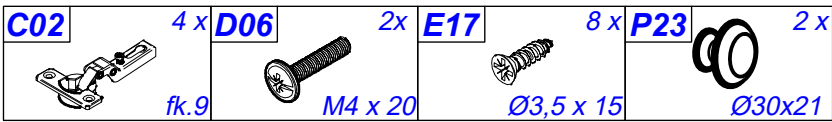

**9x 2**

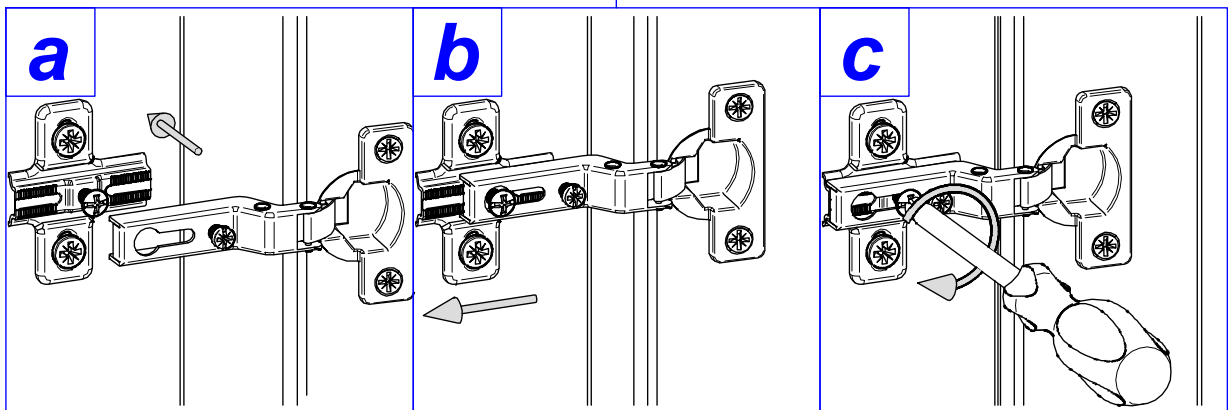
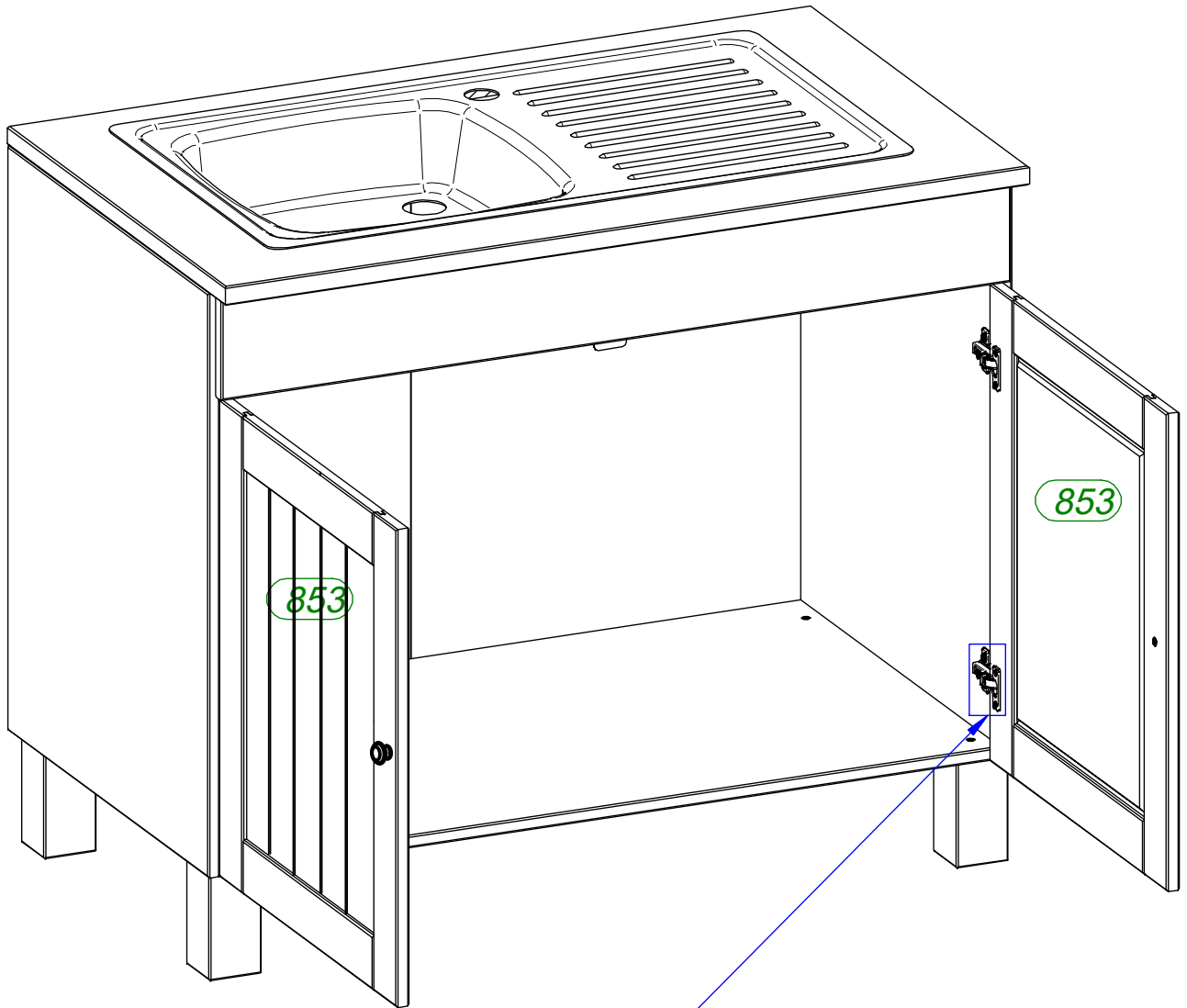

**! Achtung • Attention • Attenzione • Opgelet • Uwaga • Pozor • Figyelem • Atenție • Dikkat • Внимание !**

|             |   |
|-------------|---|
| <b>(D)</b>  | Türen einstellen (Scharniere justieren)           |
| <b>(GB)</b> | Adjusting the doors (adjusting the hinges)        |
| <b>(NL)</b> | Deuren instellen (scharnieren afstellen)          |
| <b>(PL)</b> | Nastawić drzwi (wyrównać zawiasy)                 |
| <b>(TR)</b> | Kapıların ayarlanması (menteşelerin seviye ayarı) |
| <b>(RU)</b> | Регулировка дверей (регулировка шарнира)          |
| <b>(FR)</b> | Régler les portes (ajuster les charnières)        |
| <b>(IT)</b> | Sistemare le porte (regolare le cerniere)         |
| <b>(CZ)</b> | Vyrovnejte dvířka (seřídte závěsy)                |
| <b>(SK)</b> | Nastavenie dverí (nastavenie závesov)             |
| <b>(HU)</b> | Állítsa be az ajtókat (állítsa be a zsanérokot)   |
| <b>(RO)</b> | Reglare ușii (ajustare balamale)                  |

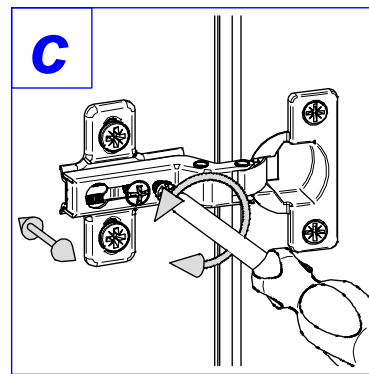
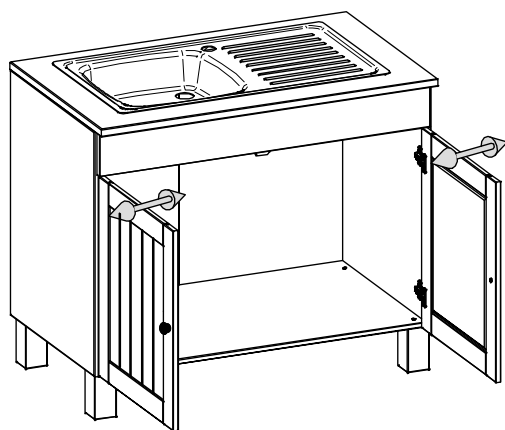
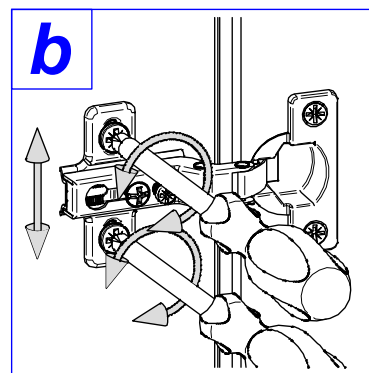
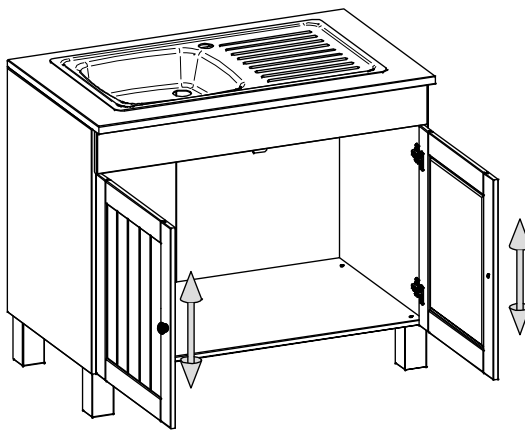
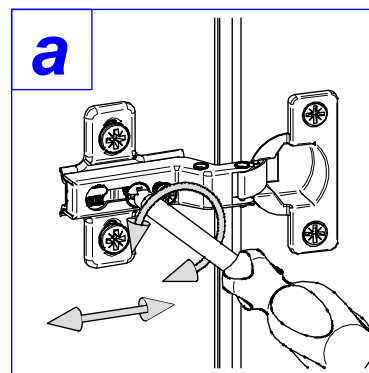
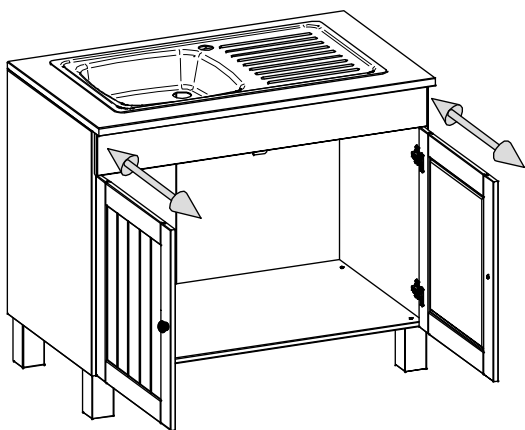

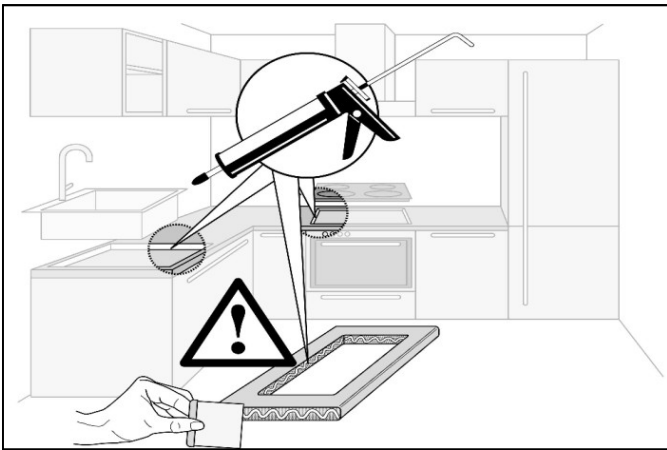
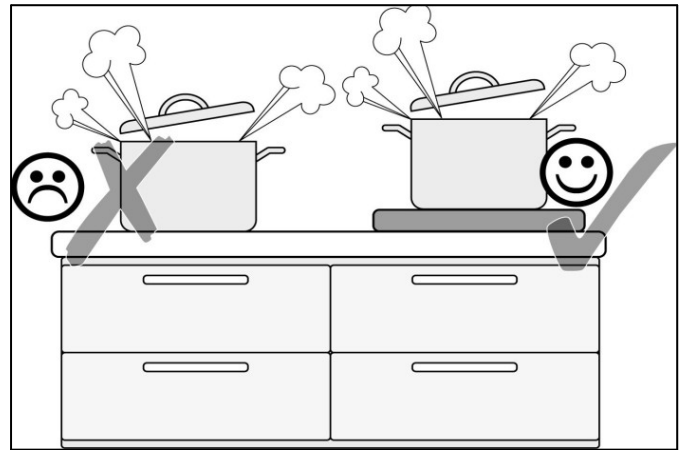
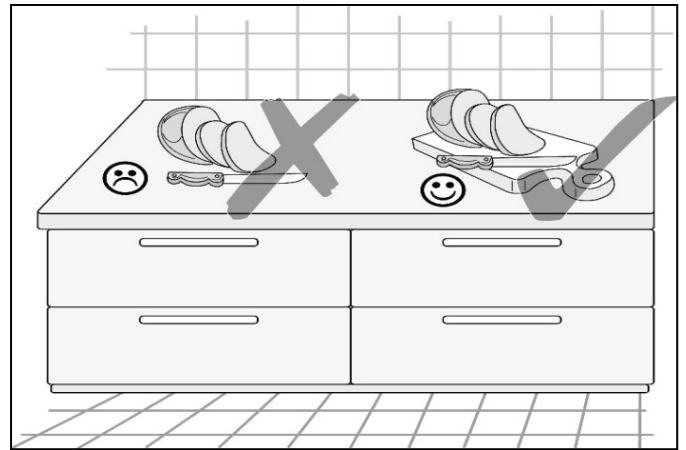
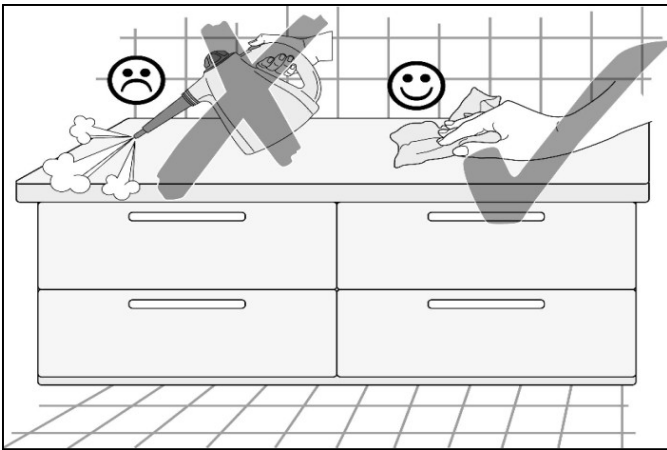
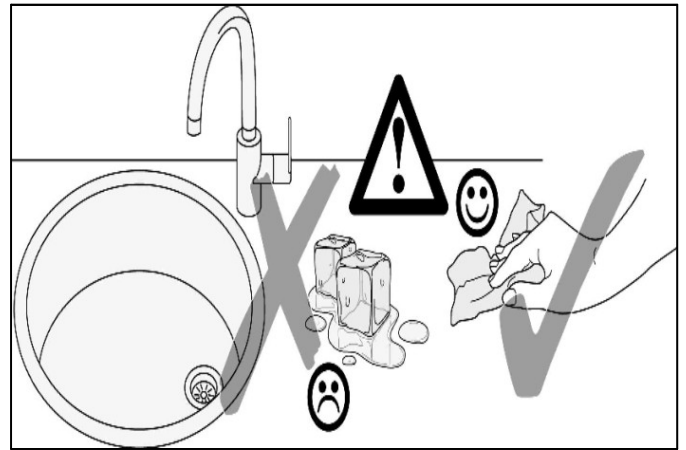
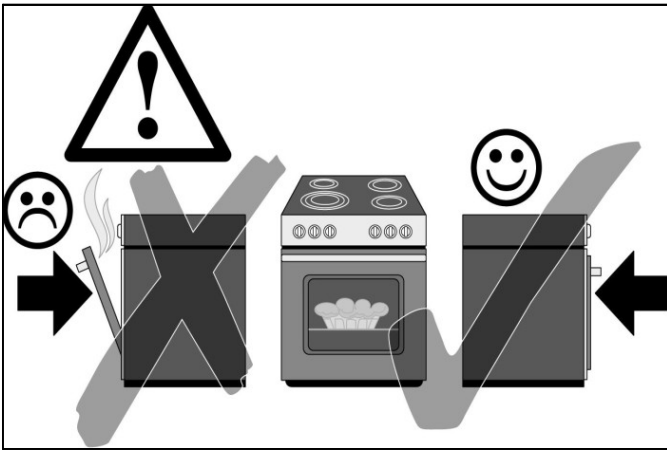

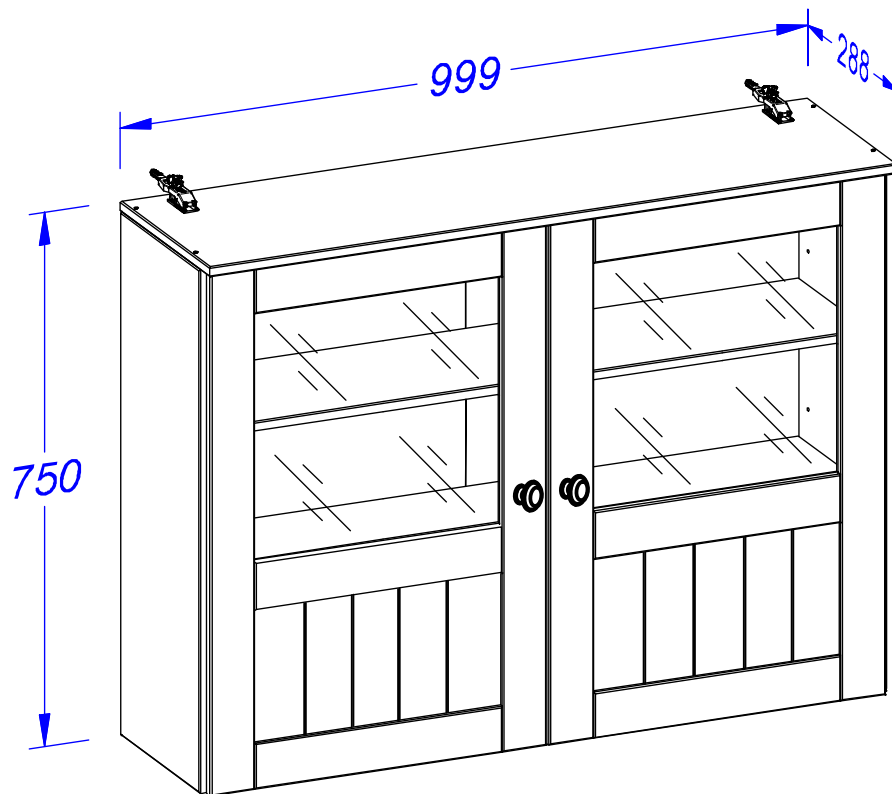

(D) *Montageanleitung*

(NL) *Handleiding voor de montage*

(TR) *Montaj talimatı*

(FR) *Notice de montage*

(CZ) *Montážní návod*

(HU) *Szerelési útmutató*

(GB) *Assembly instructions*

(PL) *Instrukcja montażu*

(RU) *Инструкция по монтажу*

(IT) *Istruzioni di montaggio*

(SK) *Návod na montáž*

(RO) *Instrucțiuni de montaj*









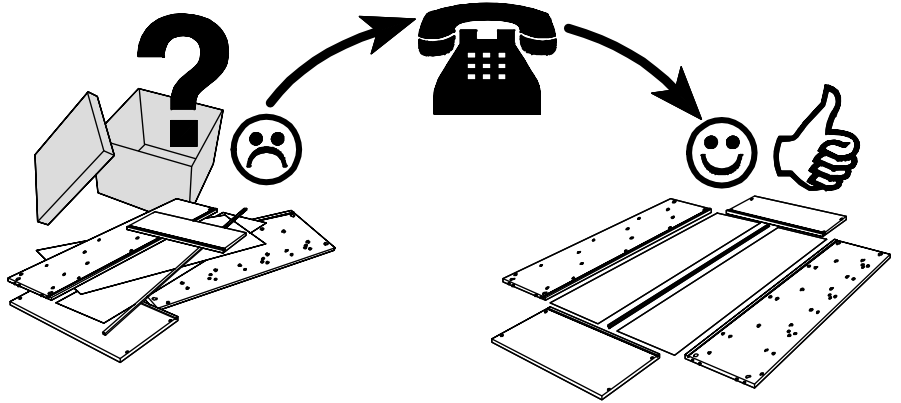
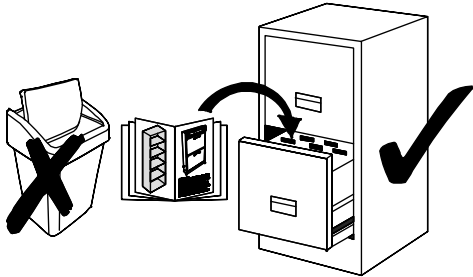

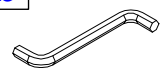

**Service • Dienstverlening • Serwis • Servis • Сервисная служба • Assistenza • Szerviz**

Name • Nom • Nome • Naam • Nazwa • Jméno •  
Názov • Név • Denumire • Isim • Название

Nr. • No. • N° • Номер • Č • Sz

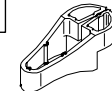
Typ • Type • Tip • Típus • Тіро • Тип



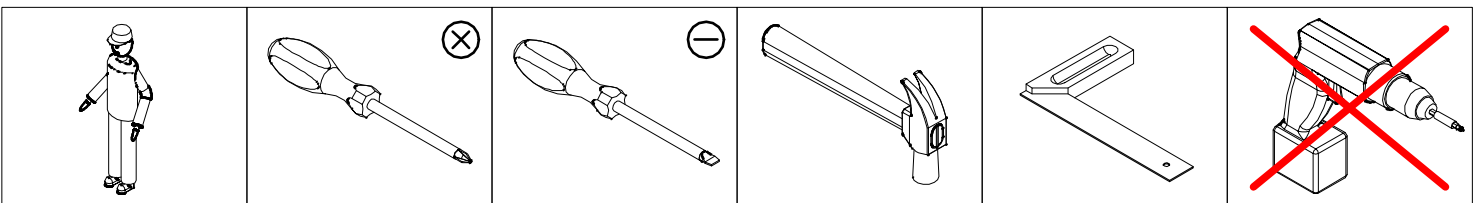

|   |     |   |     |  |     |  |      |  |     |  |     |
|---|-----|---|-----|--|-----|--|------|--|-----|--|-----|
| <b>A</b>  | 8 x | <b>C</b>  | 4 x | <b>Ce</b>  | 4 x | <b>Dd</b>  | 2 x  | <b>Ea</b>  | 8 x | <b>Fb</b>  | 1 x |
|    |     |    |     |   |     |   |      |   |     |   |     |
| $\varnothing 8 \times 35$   |     | 2 mm  |     | fk.9   |     | M4 x 20  |      | $\varnothing 3,5 \times 15$  |     | 3 mm   |     |
| <b>G</b>  | 4 x | <b>Ga</b>   | 4 x | <b>Hc</b>  | 4 x | <b>I</b>   | 50 x | <b>lb</b>  | 1 x | <b>Lk</b>  | 1 x |
|   |     |   |     |  |     |  |      |  |     |  |     |
| L - 34  |     | $\varnothing 15 \times 11$  |     | $\varnothing 5 \times 50$  |     | $\varnothing 1,2 \times 20$  |      | 45 x 20 x 16   |     | 2 set  |     |
| <b>N</b>  | 8 x | <b>No</b>   | 2 x |  |     |  |      |  |     |  |     |
|  |     |  |     |  |     |  |      |  |     |  |     |
| $\varnothing 5 / \varnothing 5$   |     | $\varnothing 30 \times 21$  |     |  |     |  |      |  |     |  |     |

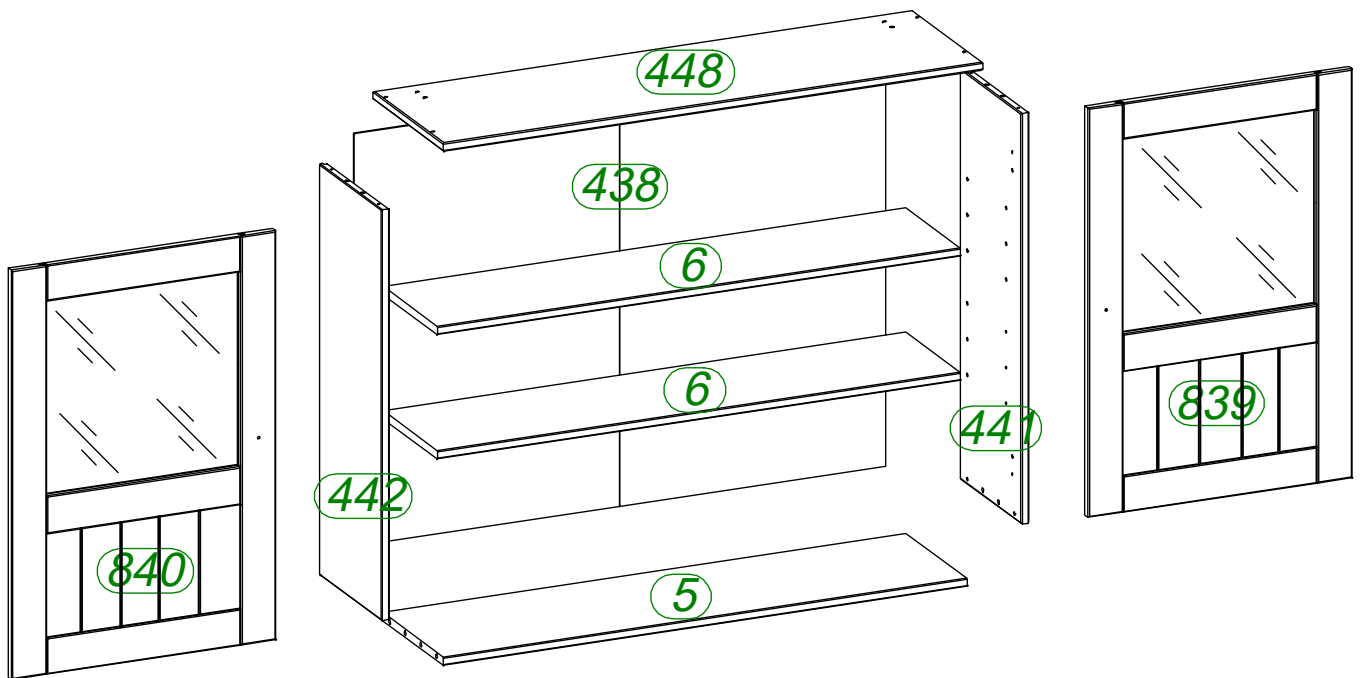

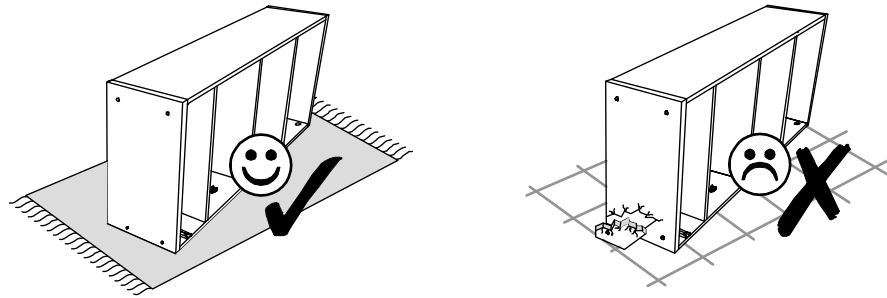



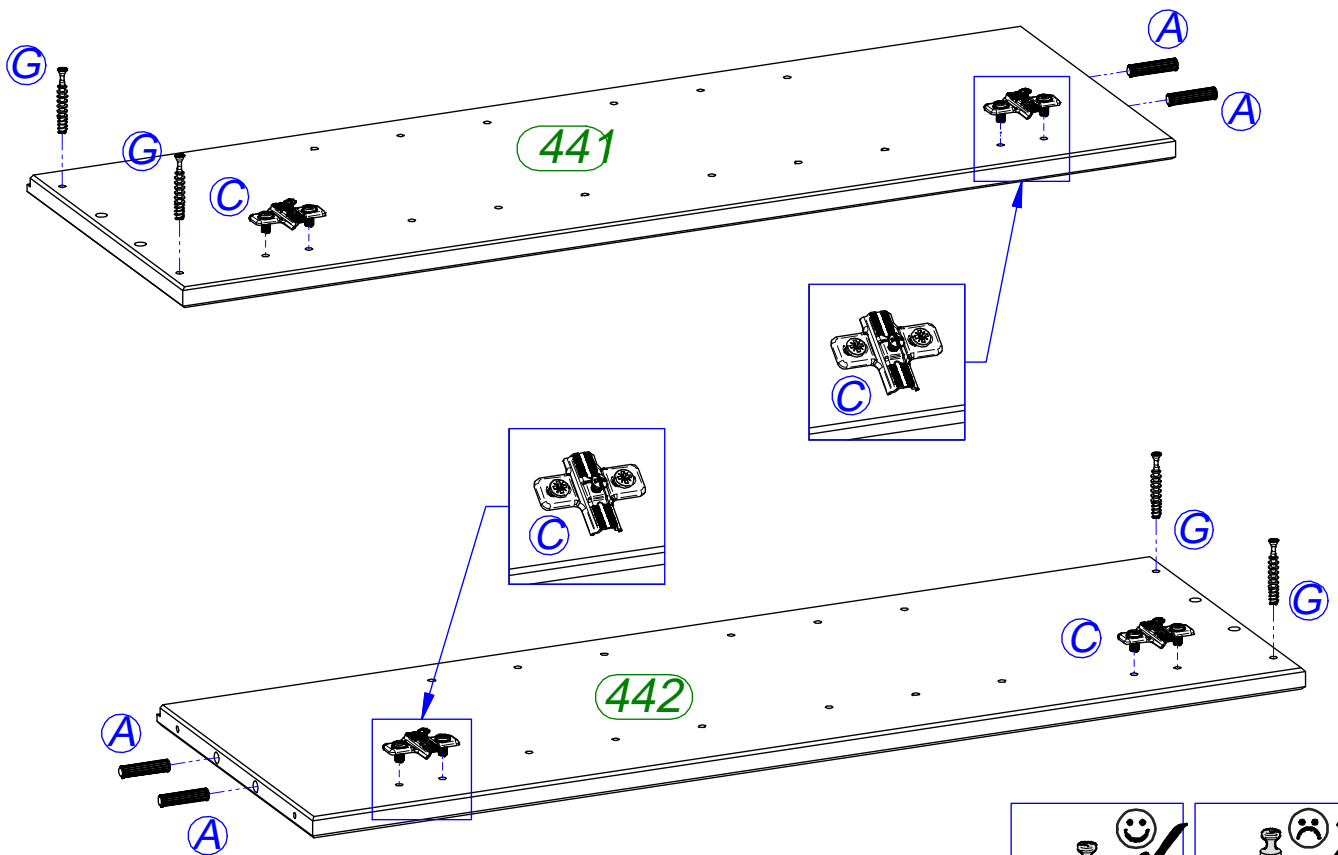

|   |     |   |     |   |     |
|---|-----|---|-----|---|-----|
| <b>A</b>  | 4 x | <b>C</b>  | 4 x | <b>G</b>  | 4 x |
|  |     |  |     |  |     |
| Ø8 x 35   |     | 2 mm  |     | L - 34  |     |

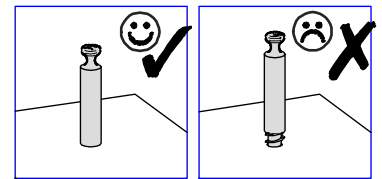

**1**



|   |     |
|---|-----|
| <b>A</b>  | 4 x |
|  |     |
| Ø8 x 35   |     |

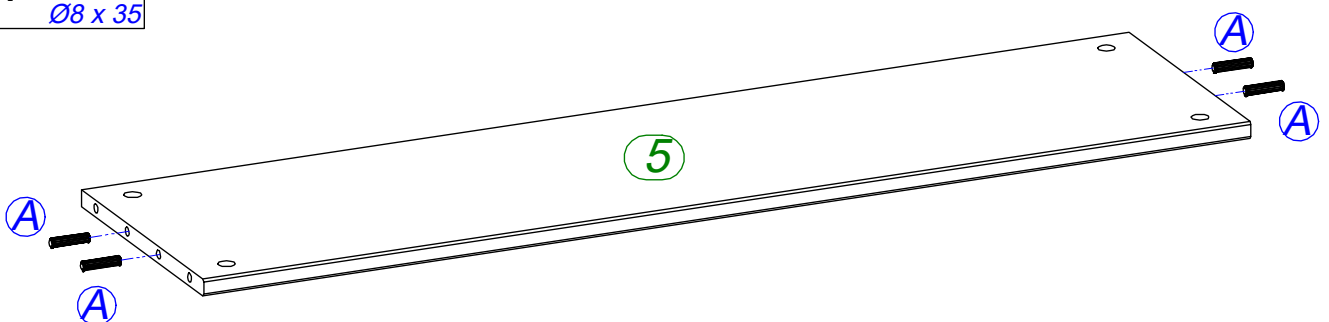

**2**



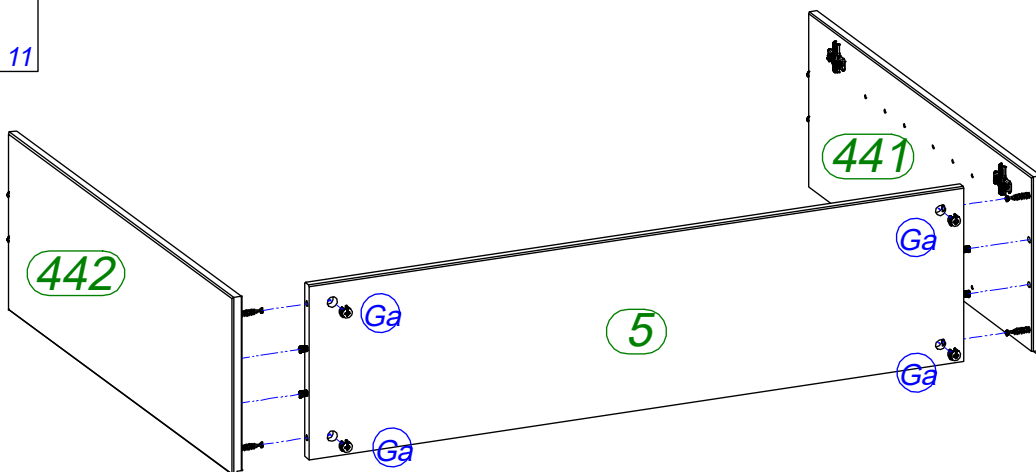
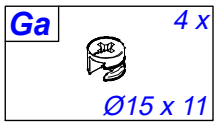

**3**

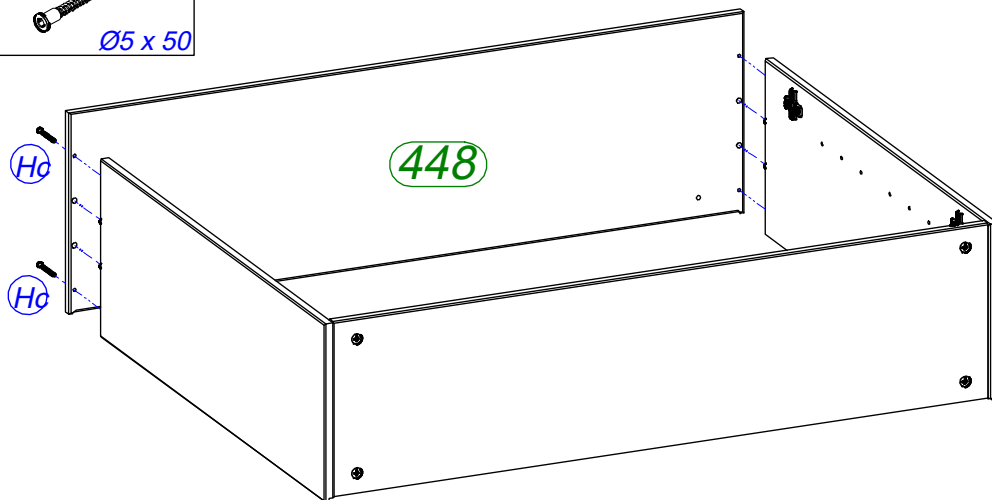
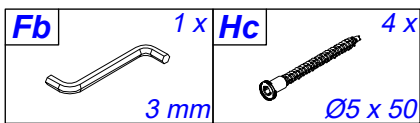

**4**

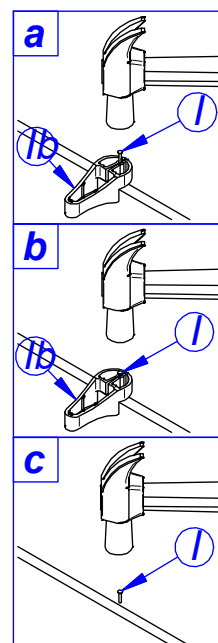
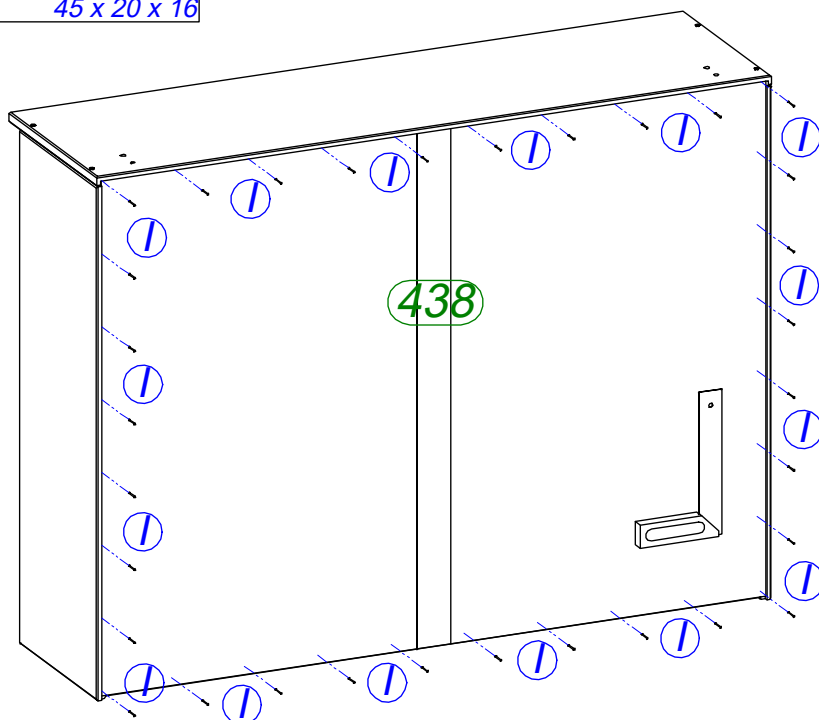
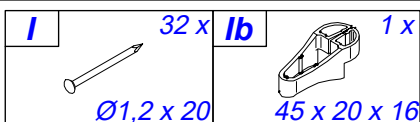

**5**

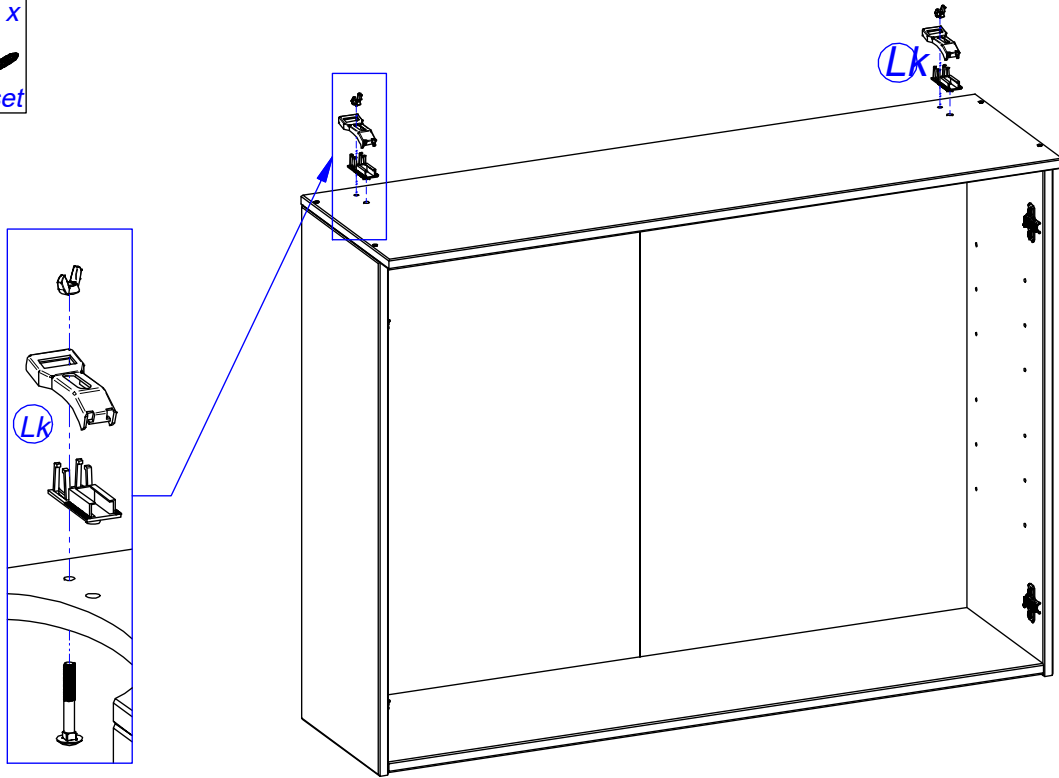
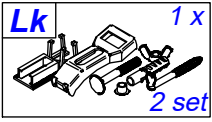

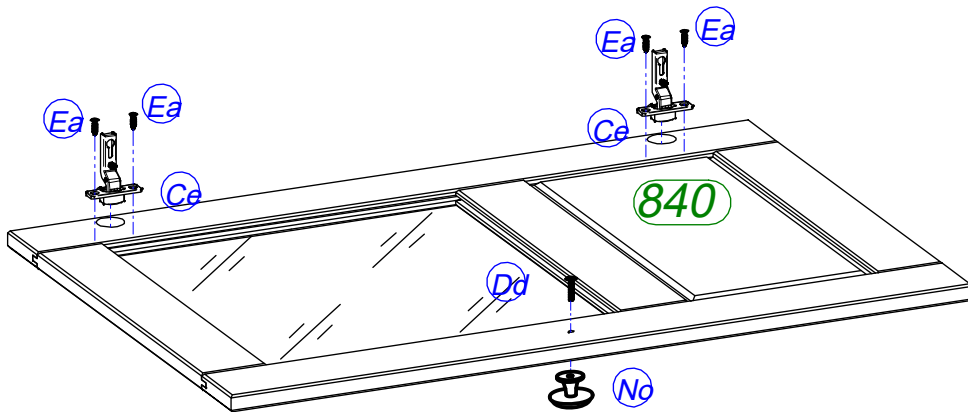
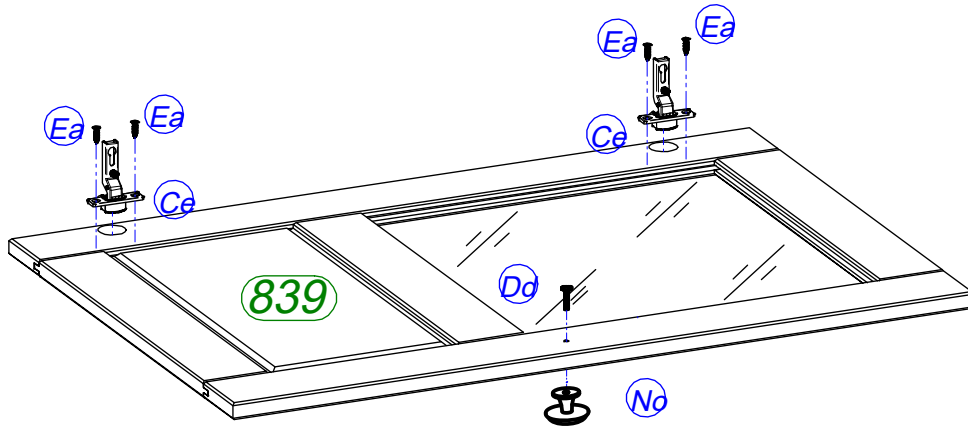
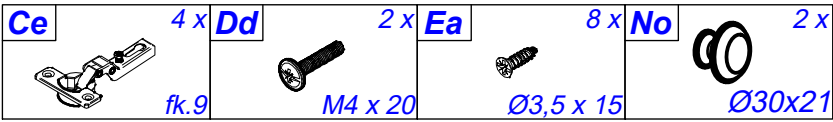

**6**



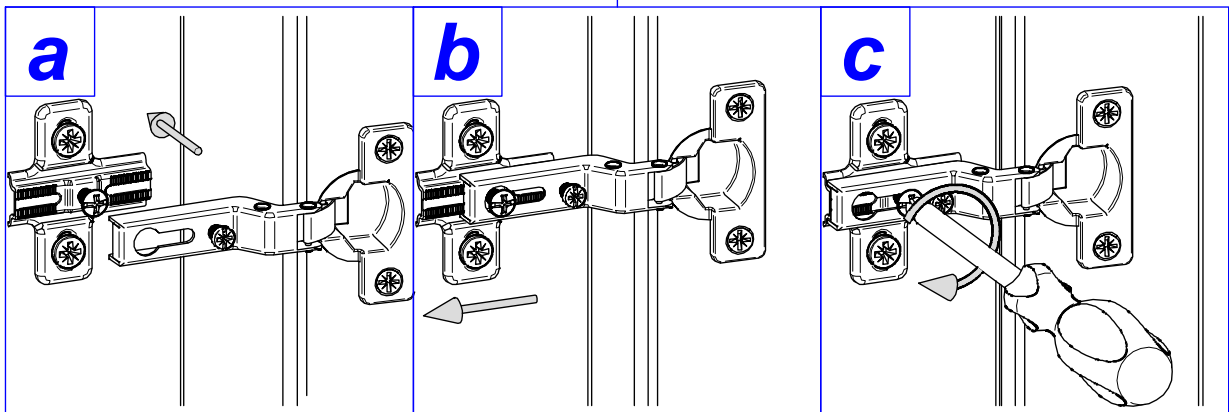
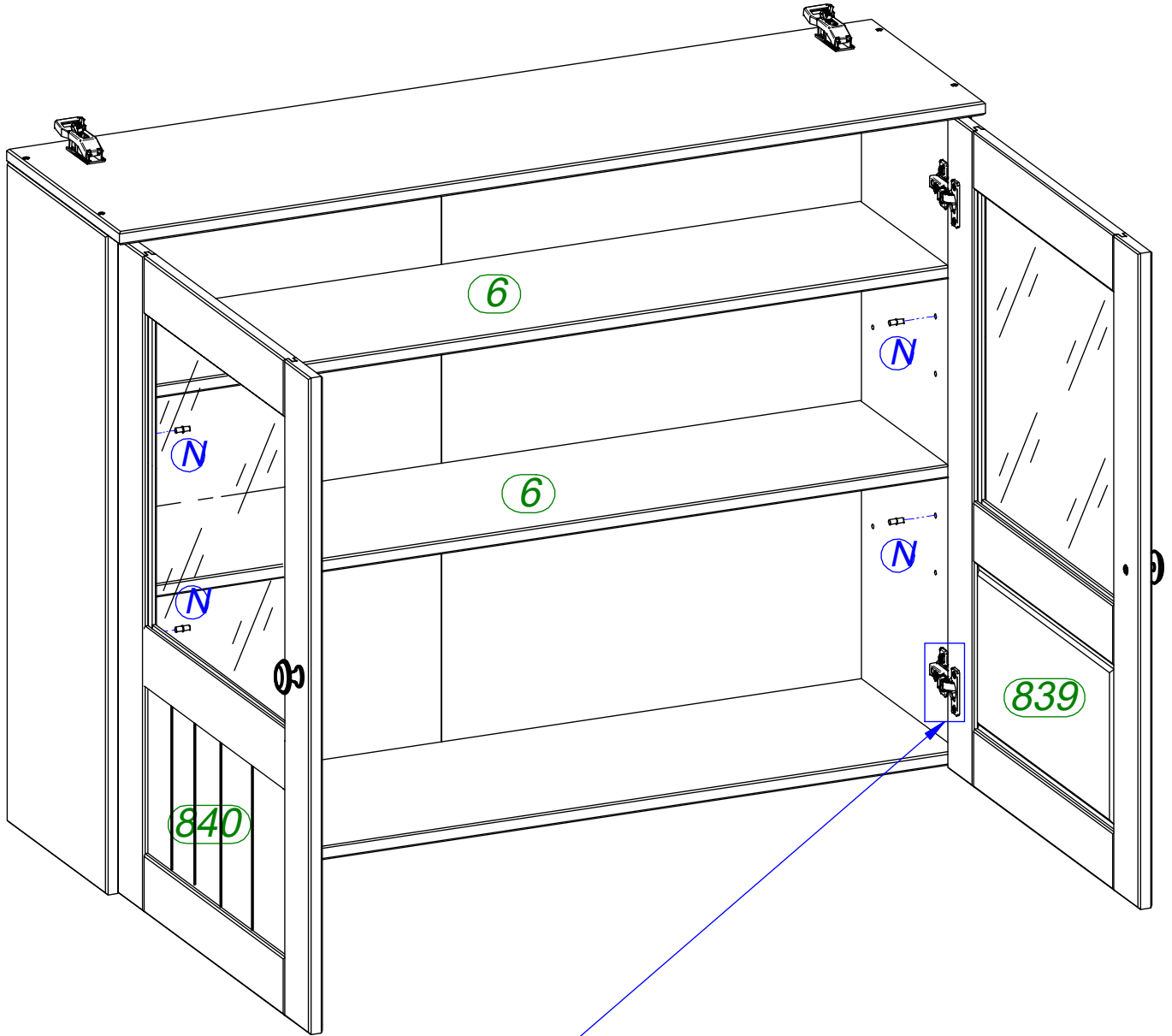
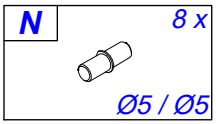

**7**

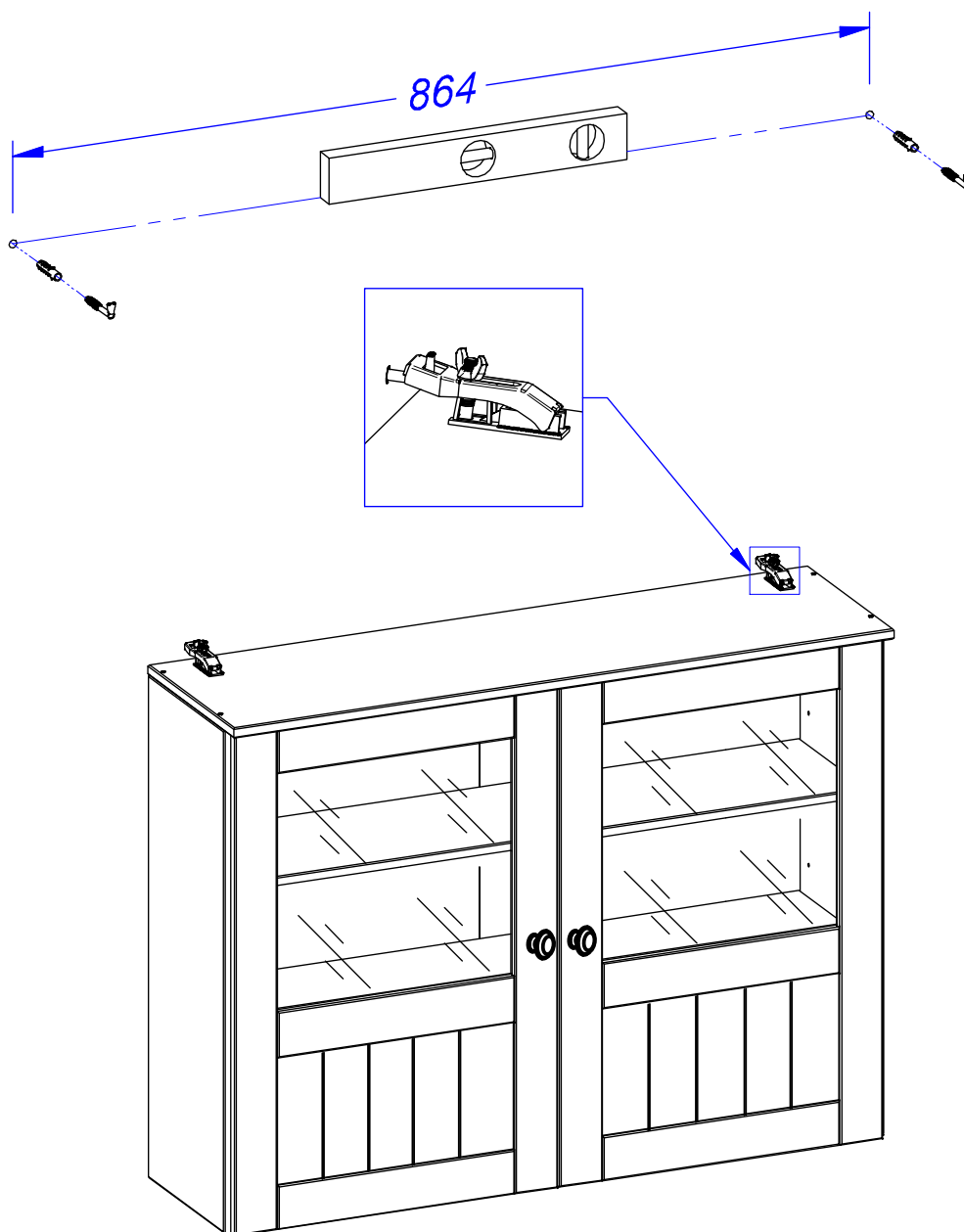

**8**

|  <b>Achtung • Attention • Attenzione • Opgelet • Uwaga • Pozor • Figyelem • Atenție • Dikkat • Внимание</b>  |   |
|---|---|
| <b>(D)</b>  | Bei einigen Wandtypen kann ein Spezialdübel erforderlich sein!              |
| <b>(GB)</b>   | For certain wall types, a special dowel may be necessary!                   |
| <b>(NL)</b>   | Bij enkele muurtypes is een speciale plug misschien vereist!                |
| <b>(PL)</b>   | Do niektórych rodzajów ścian konieczne mogą być specjalne wkręty!           |
| <b>(TR)</b>   | Bazı duvar tiplerinde bunun için özel bir dübel gerekli olabilir!           |
| <b>(RU)</b>   | Для некоторых типов стен может потребоваться специальный дюбель!            |
| <b>(FR)</b>   | Pour certains types de murs il faut des chevilles spéciales !               |
| <b>(IT)</b>   | Per alcune strutture di parete può essere necessario un tassello speciale!  |
| <b>(CZ)</b>   | U některých typů stěn může být zapotřebí speciální hmoždinka!               |
| <b>(SK)</b>   | Pre niektoré druhy stien môže byť potrebná špeciálna hmoždinka!             |
| <b>(HU)</b>   | Egyes faltípusoknál speciális tiplít kell használni!                        |
| <b>(RO)</b>   | Pentru unele tipuri de pereți este posibil să fie necesar un diblu special! |



|  <b>Achtung • Attention • Attenzione • Opgelet • Uwaga • Pozor • Figyelem • Atenție • Dikkat • Внимание</b>  |   |
|---|---|
| <b>(D)</b>  | Türen einstellen (Scharniere justieren)           |
| <b>(GB)</b>   | Adjusting the doors (adjusting the hinges)        |
| <b>(NL)</b>   | Deuren instellen (scharnieren afstellen)          |
| <b>(PL)</b>   | Nastawić drzwi (wyrównać zawiasy)                 |
| <b>(TR)</b>   | Kapıların ayarlanması (menteşelerin seviye ayarı) |
| <b>(RU)</b>   | Регулировка дверей (регулировка шарнира)          |
| <b>(FR)</b>   | Régler les portes (ajuster les charnières)        |
| <b>(IT)</b>   | Sistemare le porte (regolare le cerniere)         |
| <b>(CZ)</b>   | Vyrovnejte dvířka (seřídte závěsy)                |
| <b>(SK)</b>   | Nastavenie dverí (nastavenie závesov)             |
| <b>(HU)</b>   | Állítsa be az ajtókat (állítsa be a zsanérokat)   |
| <b>(RO)</b>   | Reglare ușii (ajustare balamale)                  |

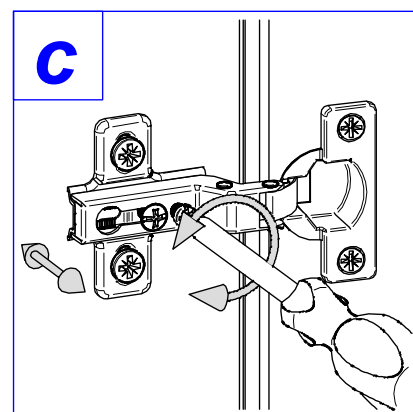
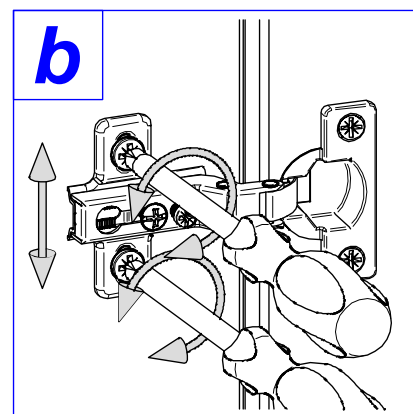
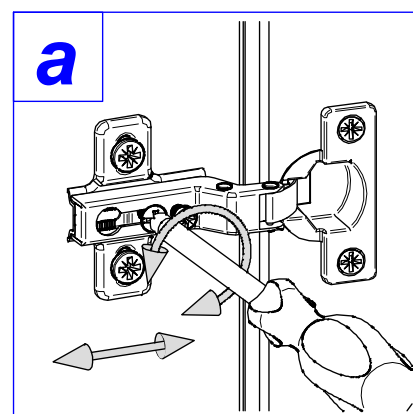
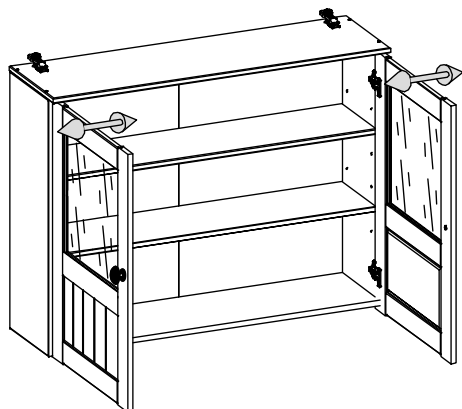
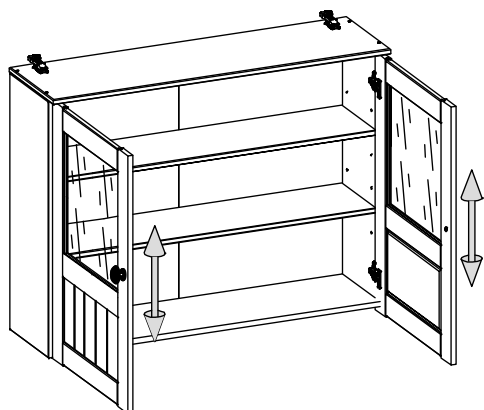
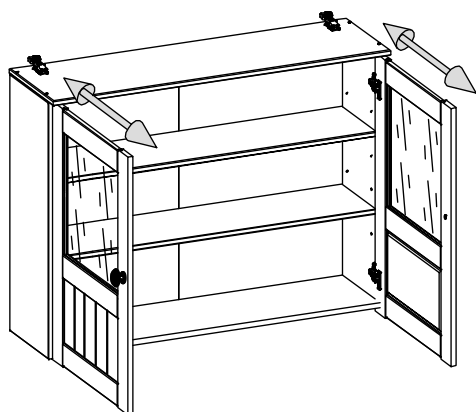

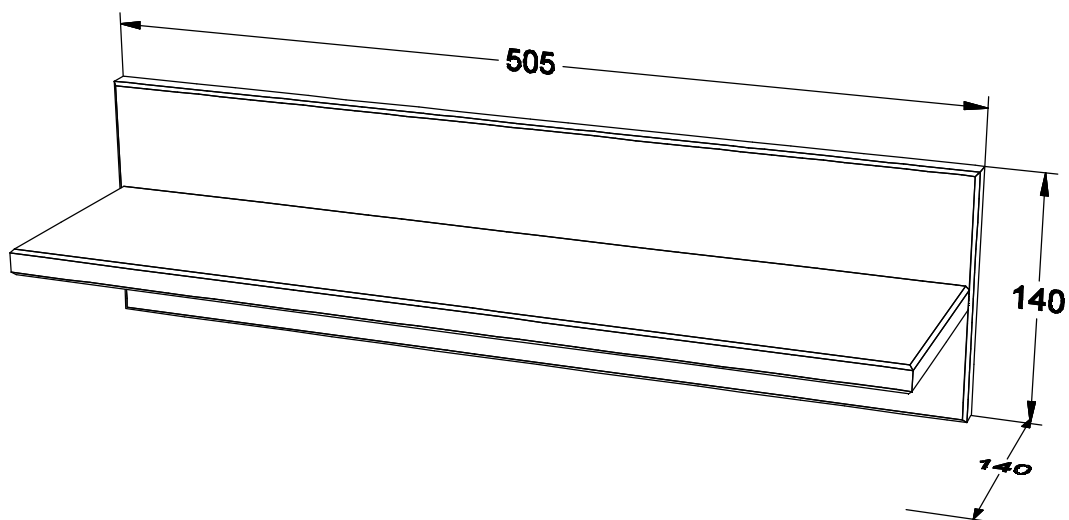

**(D)** *Montageanleitung*

**(NL)** *Handleiding voor de montage*

**(TR)** *Montaj talimatı*

**(FR)** *Notice de montage*

**(CZ)** *Montážní návod*

**(HU)** *Szerelési útmutató*

**(GB)** *Assembly instructions*

**(PL)** *Instrukcja montażu*

**(RU)** *Инструкция по монтажу*

**(IT)** *Istruzioni di montaggio*

**(SK)** *Návod na montáž*

**(RO)** *Instrucțiuni de montaj*

Name • Nom • Nome • Naam • Nazwa • Jméno •  
Názov • Név • Denumire • Isim • Название

Nr. • No. • N° • Номер • Č • Sz

Typ • Type • Tip • Típus • Tipo • Тип

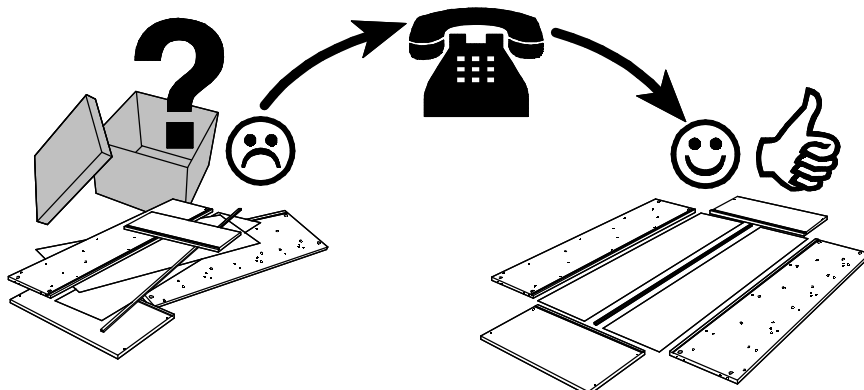
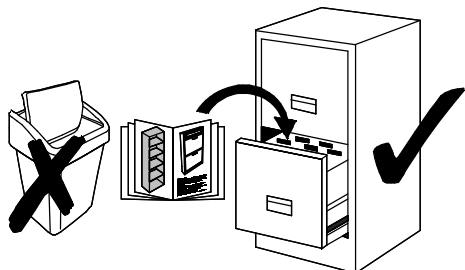

|          |     |           |     |           |     |           |     |          |     |           |     |
|----------|-----|-----------|-----|-----------|-----|-----------|-----|----------|-----|-----------|-----|
| <b>A</b> | 3 x | <b>AA</b> | 1 x | <b>AT</b> | 2 x | <b>Fa</b> | 1 x | <b>H</b> | 2 x | <b>P</b>  | 2 x |
|          |     |           |     |           |     |           |     |          |     |           |     |
| Ø8 x 35  |     | 4 mm      |     | Ø20 x 9   |     |           |     | Ø7 x 50  |     | Ø4,0 x 60 |     |

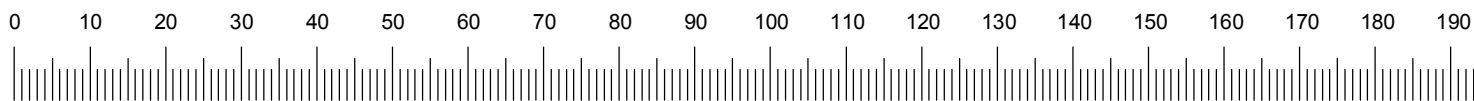
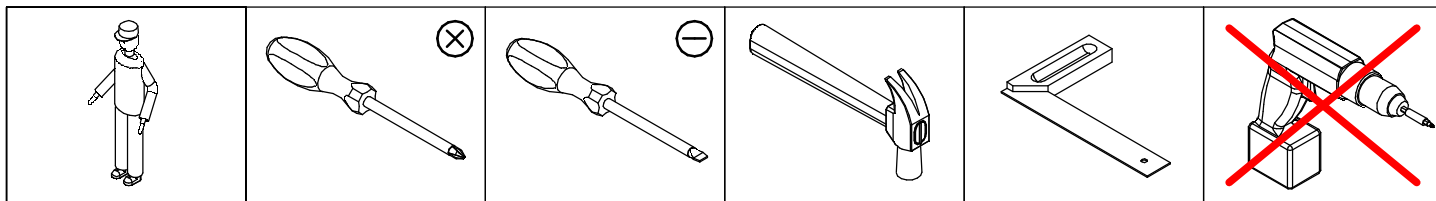
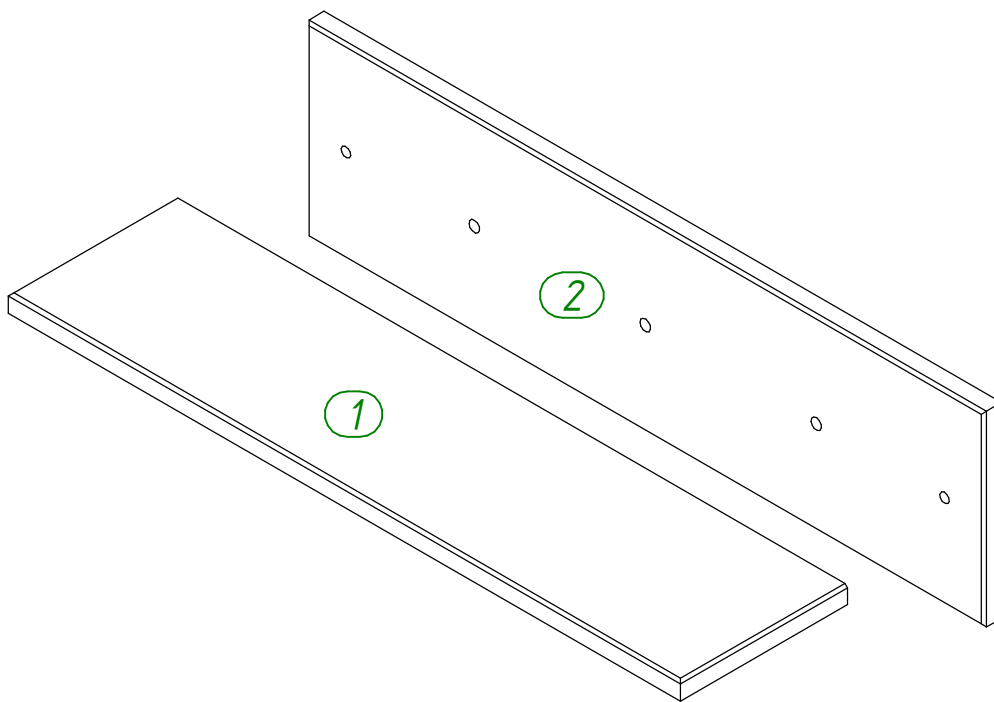

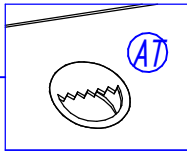
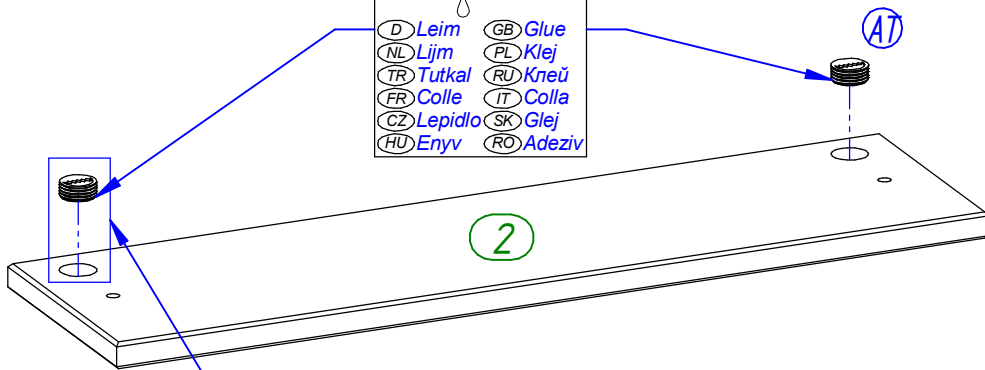
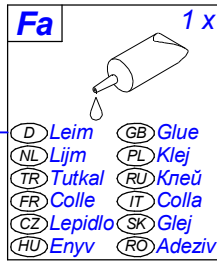
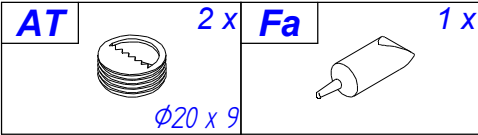
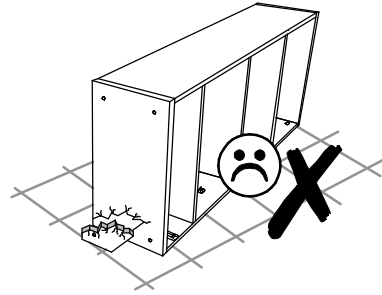
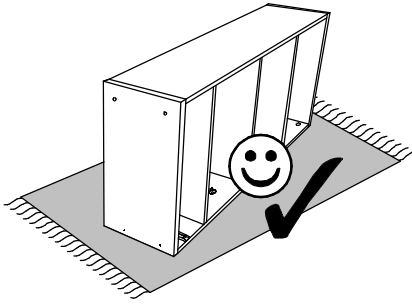

1

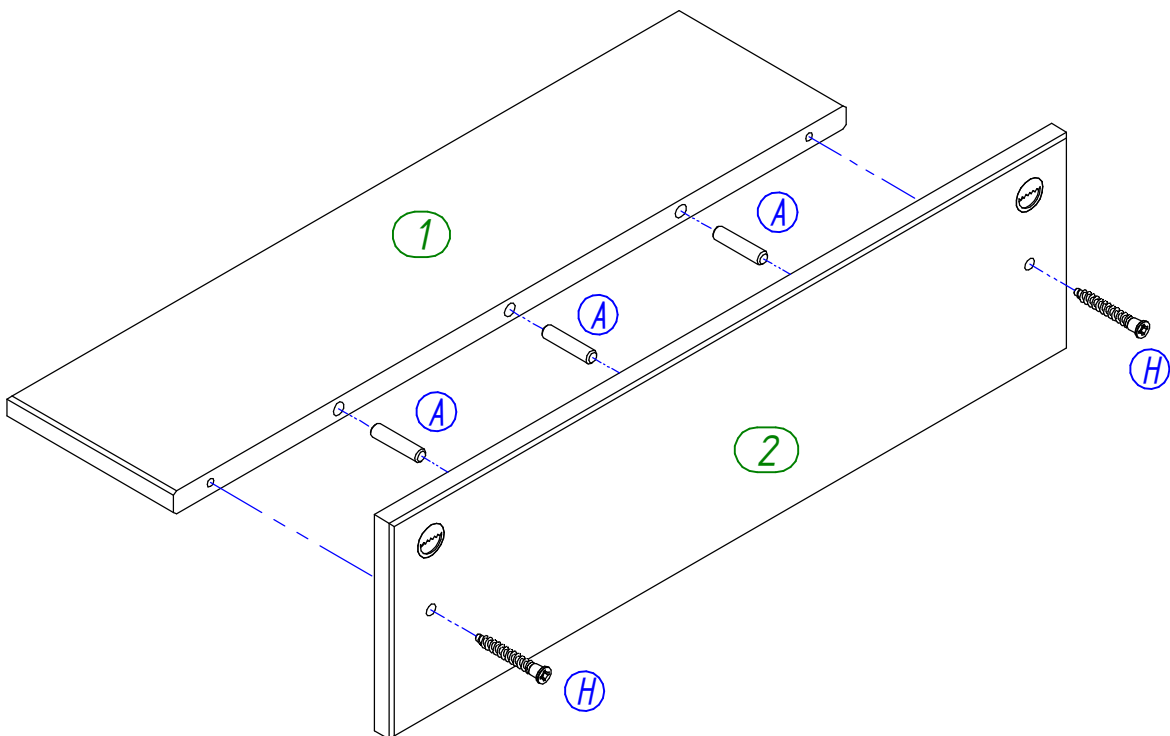
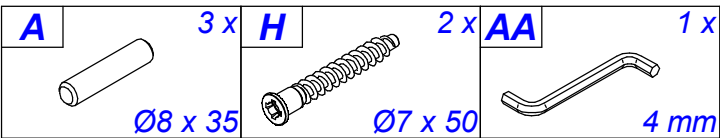
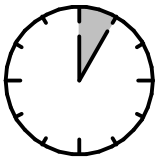

2



|             |   |
|-------------|---|
| <b>(D)</b>  | Bei einigen Wandtypen kann ein Spezialdübel erforderlich sein!              |
| <b>(GB)</b> | For certain wall types, a special dowel may be necessary!                   |
| <b>(NL)</b> | Bij enkele muurtypes is een speciale plug misschien vereist!                |
| <b>(PL)</b> | Do niektórych rodzajów ścian konieczne mogą być specjalne wkręty!           |
| <b>(TR)</b> | Bazı duvar tiplerinde bunun için özel bir dübel gerekli olabilir!           |
| <b>(RU)</b> | Для некоторых типов стен может потребоваться специальный дюбель!            |
| <b>(FR)</b> | Pour certains types de murs il faut des chevilles spéciales !               |
| <b>(IT)</b> | Per alcune strutture di parete può essere necessario un tassello speciale!  |
| <b>(CZ)</b> | U některých typů stěn může být zapotřebí speciální hmoždinka!               |
| <b>(SK)</b> | Pre niektoré druhy stien môže byť potrebná špeciálna hmoždinka!             |
| <b>(HU)</b> | Egyes faltípusoknál speciális tiplít kell használni!                        |
| <b>(RO)</b> | Pentru unele tipuri de pereți este posibil să fie necesar un diblu special! |

