

»2637«

- | | |
|----------------------------------|------------------------------|
| (D) Montageanleitung | (GB) Assembly instructions |
| (NL) Handleiding voor de montage | (PL) Instrukcja montażu |
| (TR) Montaj talimatı | (RU) Инструкция по монтажу |
| (FR) Notice de montage | (IT) Istruzioni di montaggio |
| (CZ) Montážní návod | (SK) Návod na montáž |
| (HU) Szerelési útmutató | (RO) Instrucțiuni de montaj |

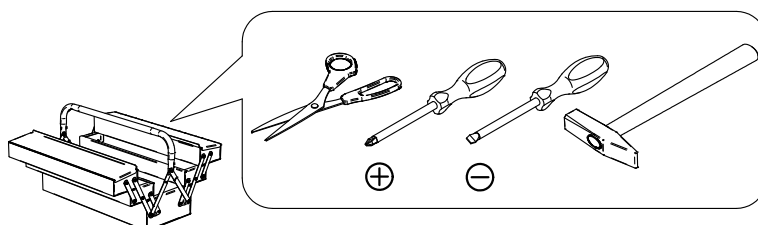
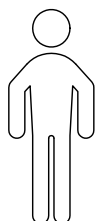

Name • Nom • Nome • Naam • Nazwa • Jméno •
Názov • Név • Denumire • Isim • Название

Nr. • No. • N° • Номер • Č • Sz

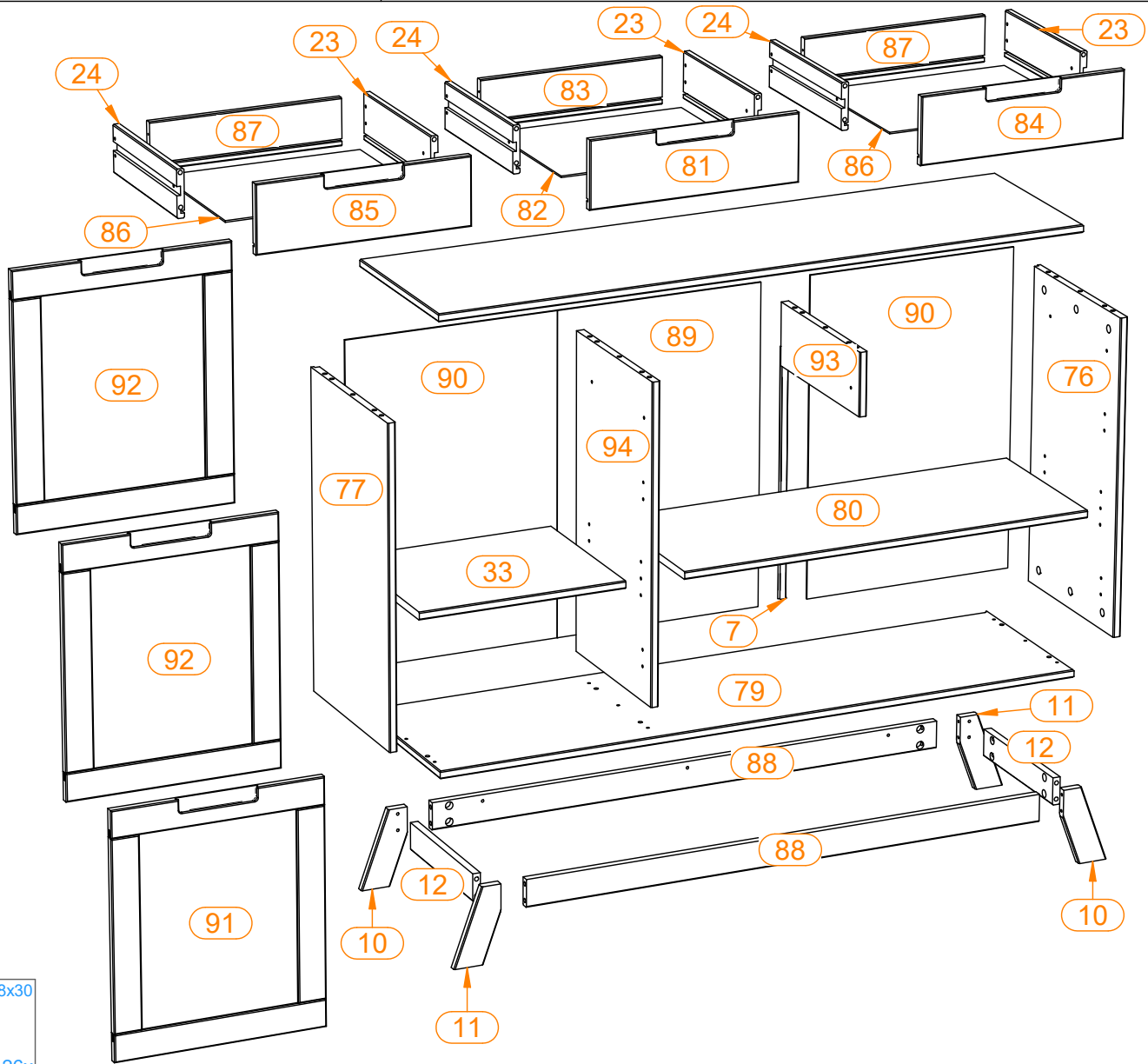
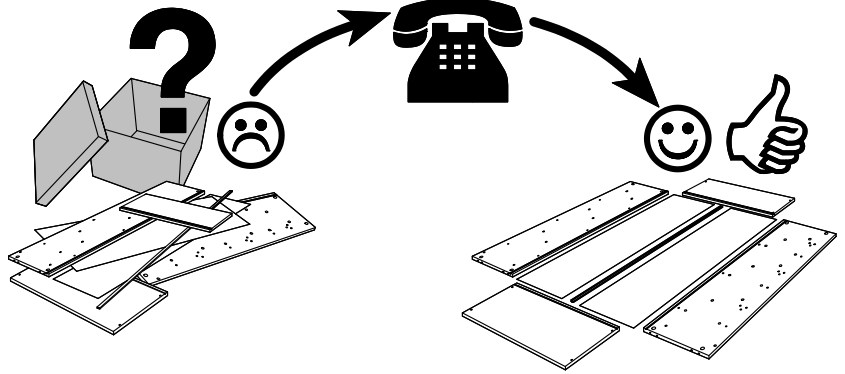
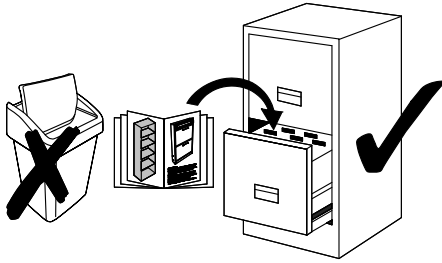

Typ • Type • Tip • Típus • Тíро • Тип

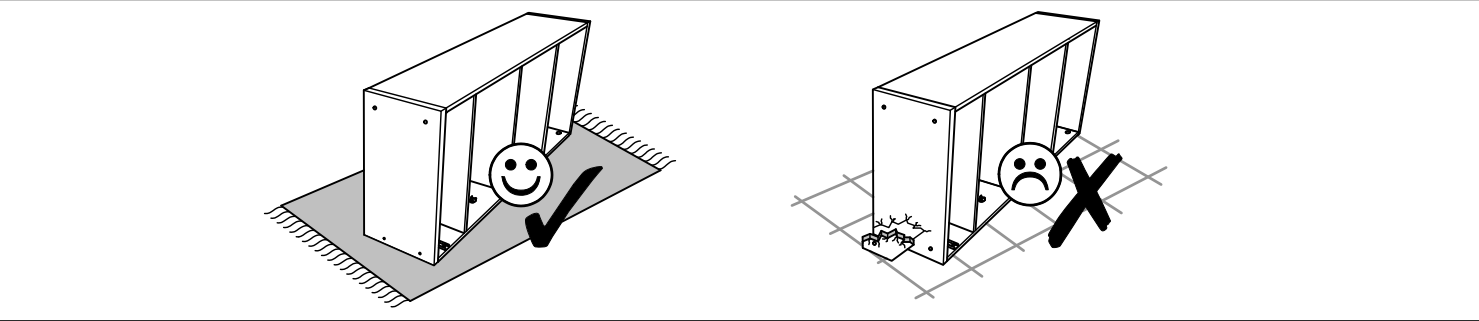

A	Ø8x30	26x	Ba	Ø6,3x12/7,7	12x	Bb	Ø5,8x8/6,5	12x	C	2 mm	6x	Cc	Ø26 (fk.9)	2x	Ce	Ø26 (fk.17)	4x	D	M4x10	6x	E	Ø3,5x35	12x	Eb	Ø3,5x15	12x	F	Glue Klej Kлей Colla Glej Adeziv 1x
G	Ø15x11	37x	Ga	Ø7x34/45	37x	I	Ø1,2x20	50x	Ia	45x20x16	1x	K	20x20x16/6,5	6x	N	Ø5/Ø5	8x	Q	17x278	6x	U	Ø17x3	4x					



1

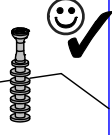

Ga Ø7x34/45	U Ø17x3
	
16x	4x

2x

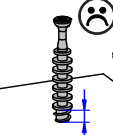



2

Ba Ø6,3x12/7,7	K 20x20x16/6,5
	
6x	6x

2x

3

G Ø15x11	
	
8x	



2x

4

G Ø15x11	
	
8x	

2x

5

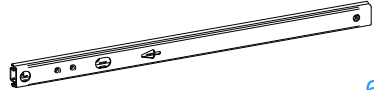
A	∅8x30	Bb	∅5,8x8/6,5	C	2 mm	Q	17x278
							
	14x		12x		6x		6x

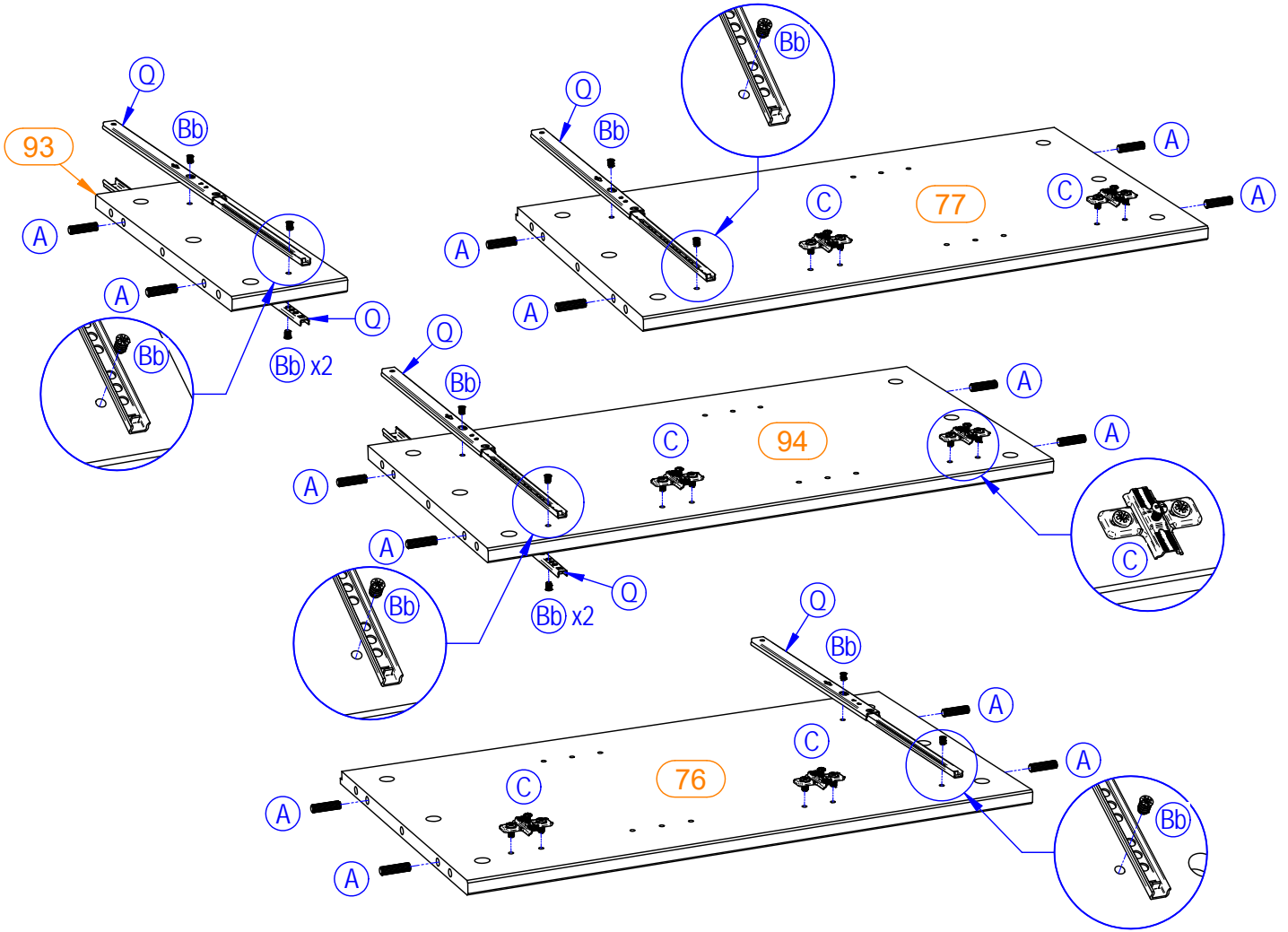

6

Ga	∅7x34/45
	
	21x

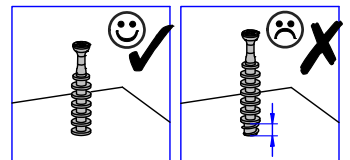
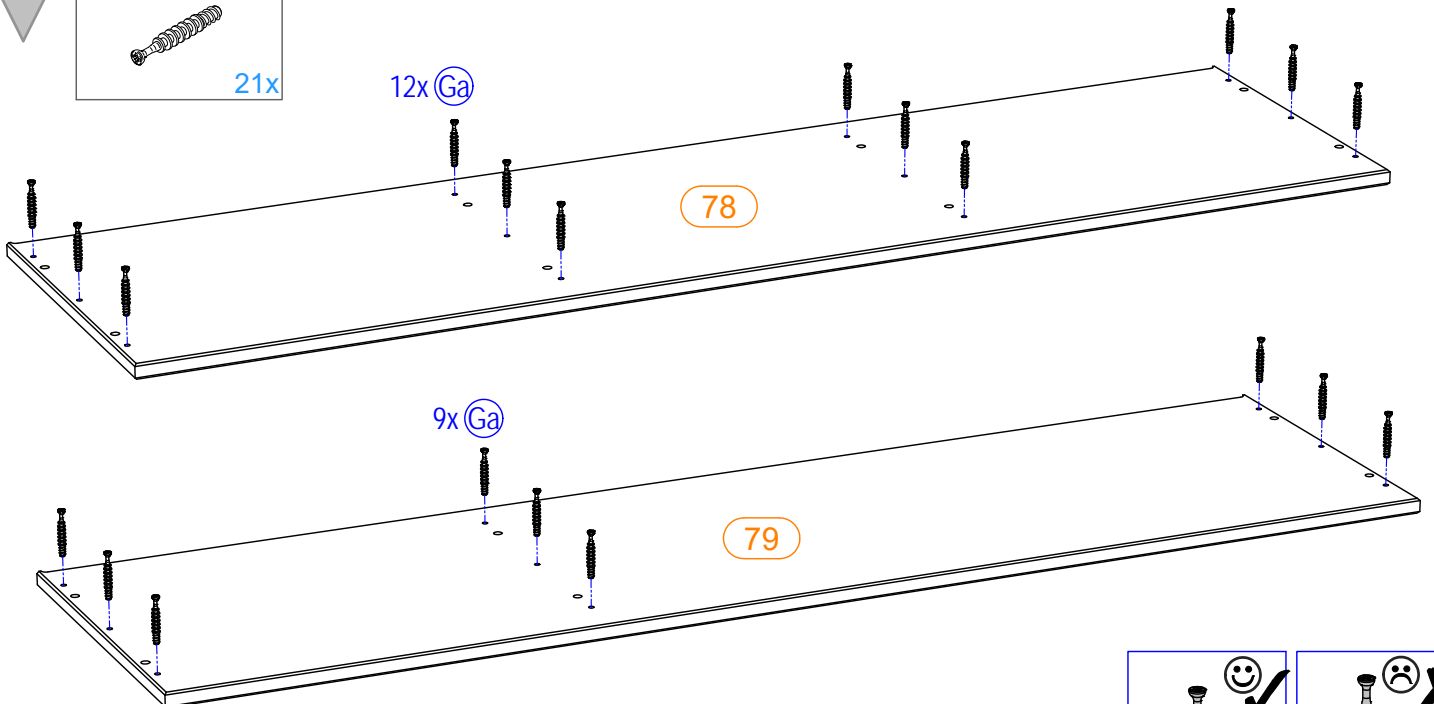

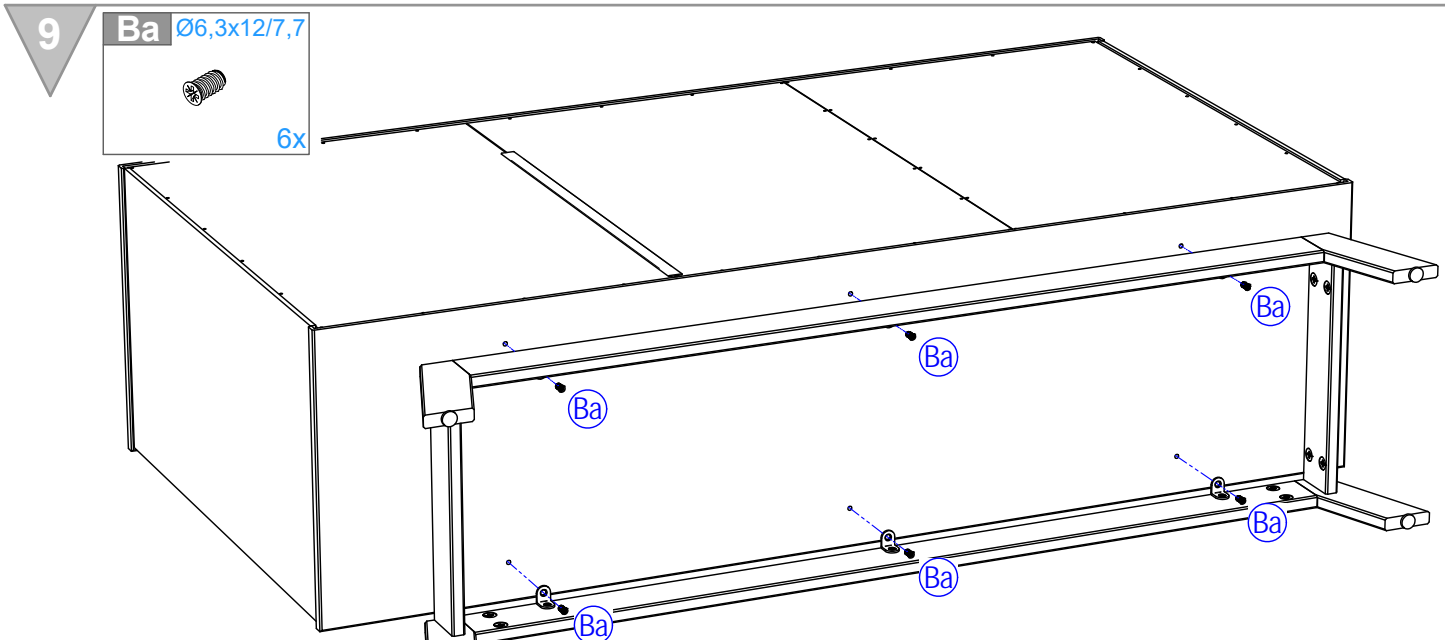
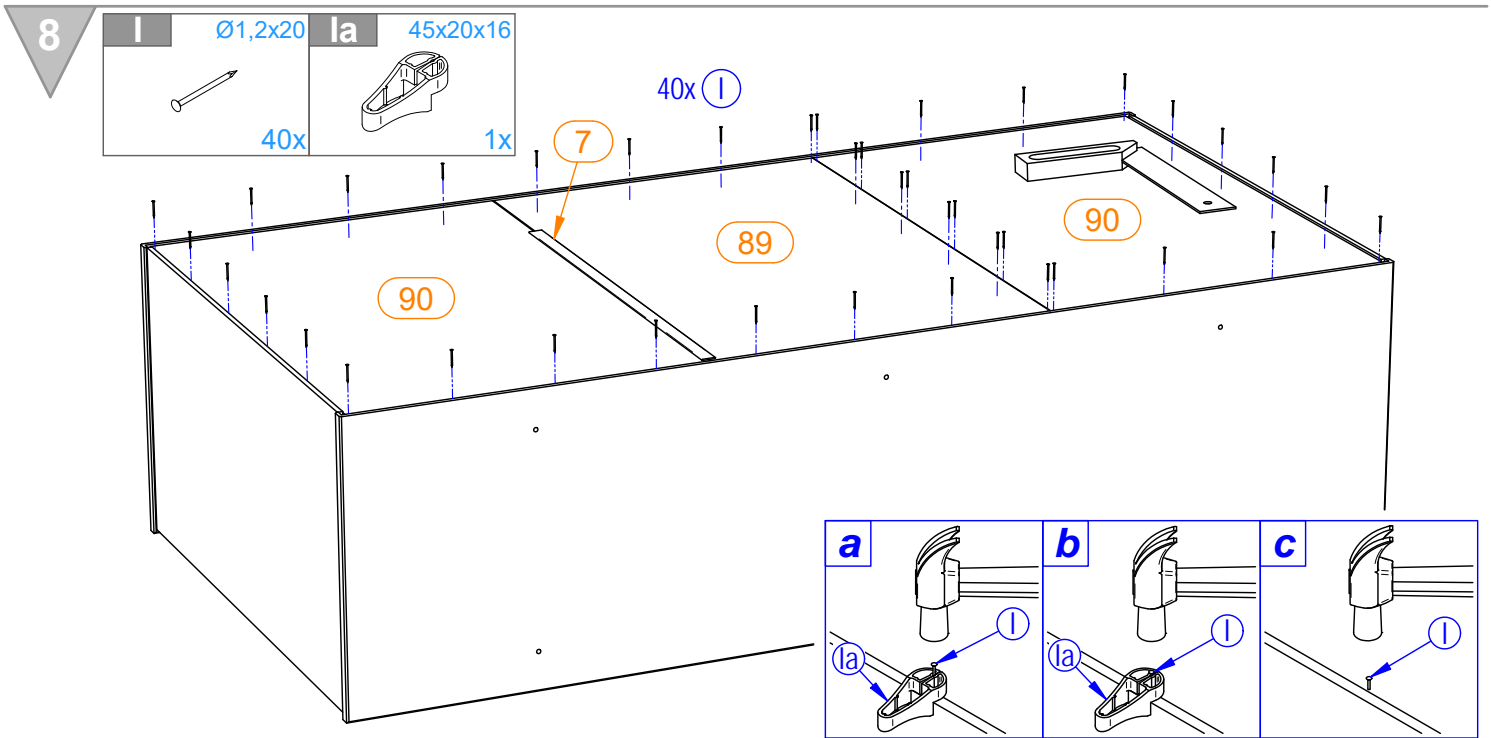
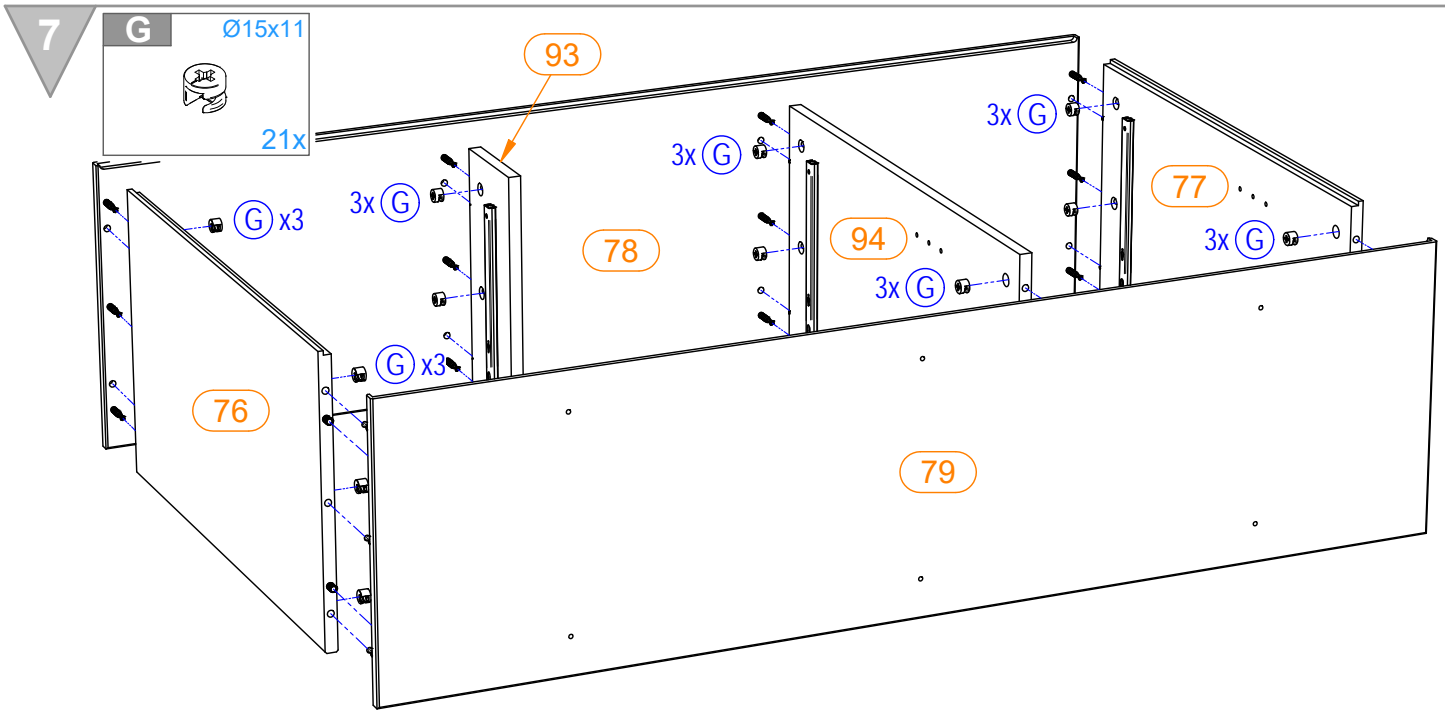

10

- A** Ø8x30
12x
- E** Ø3,5x35
12x
- F**
 GB Glue
 PL Klej
 RU Клей
 NL Lijm
 IT Colla
 TR Tutkal
 FR Colle
 CZ Lepidlo
 HU Enyv

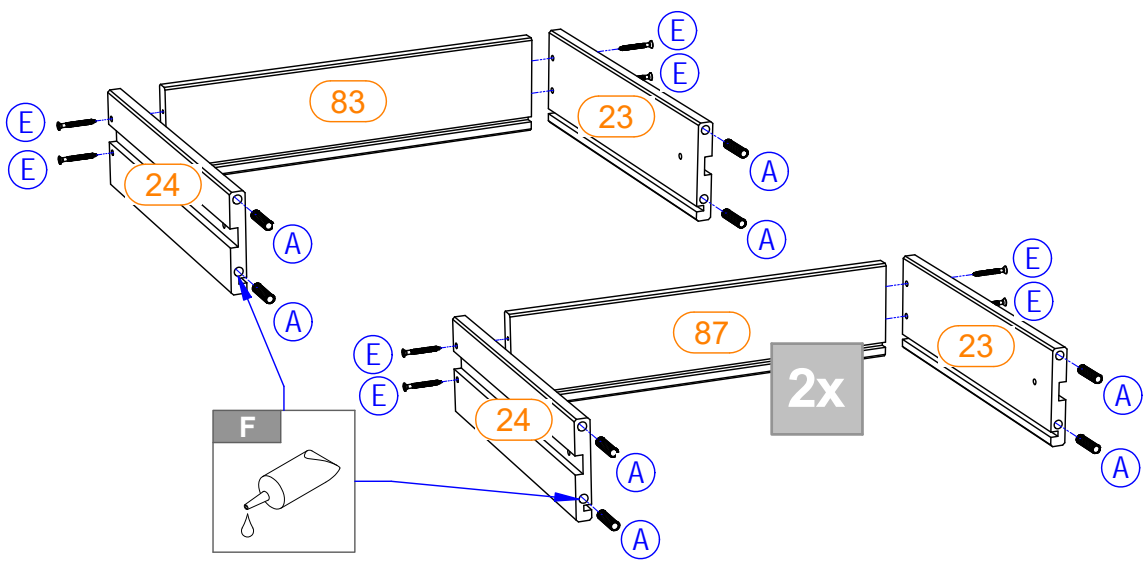

11

- F**
 GB Glue
 PL Klej
 RU Клей
 NL Lijm
 IT Colla
 TR Tutkal
 FR Colle
 CZ Lepidlo
 HU Enyv

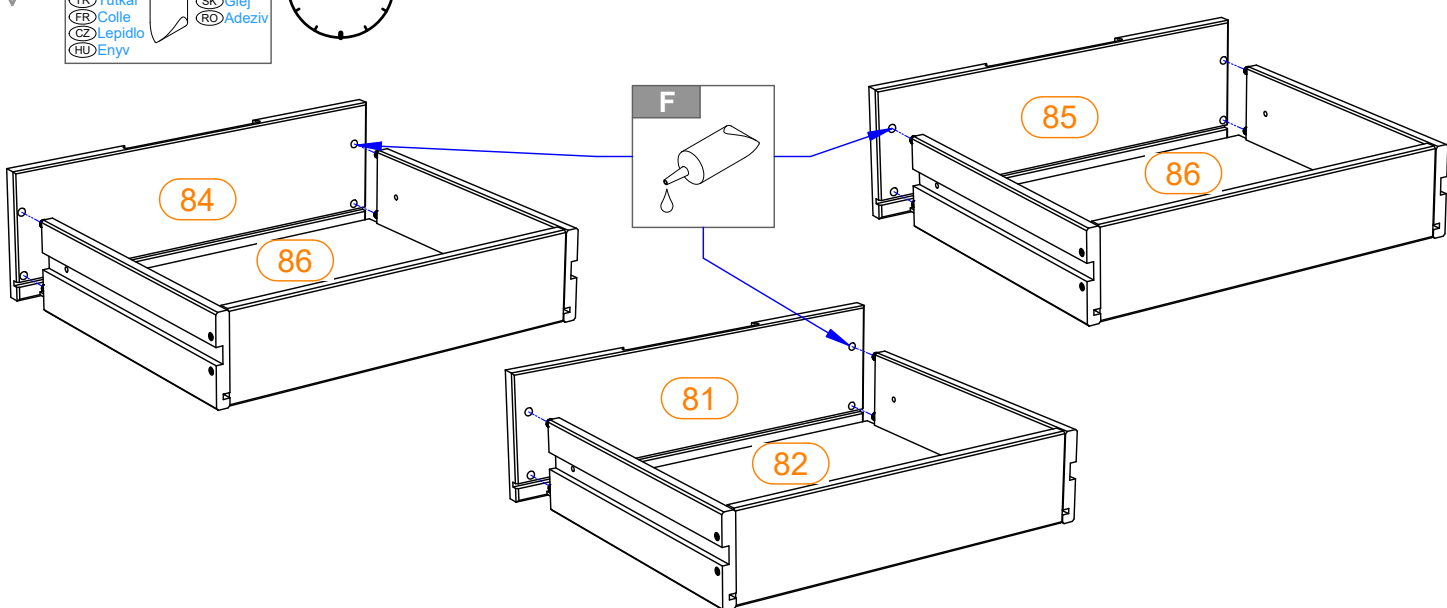
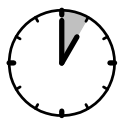

12

- Cc** Ø26 (fk.9) 2x
- Ce** Ø26 (fk.17) 4x
- Eb** Ø3,5x15 12x

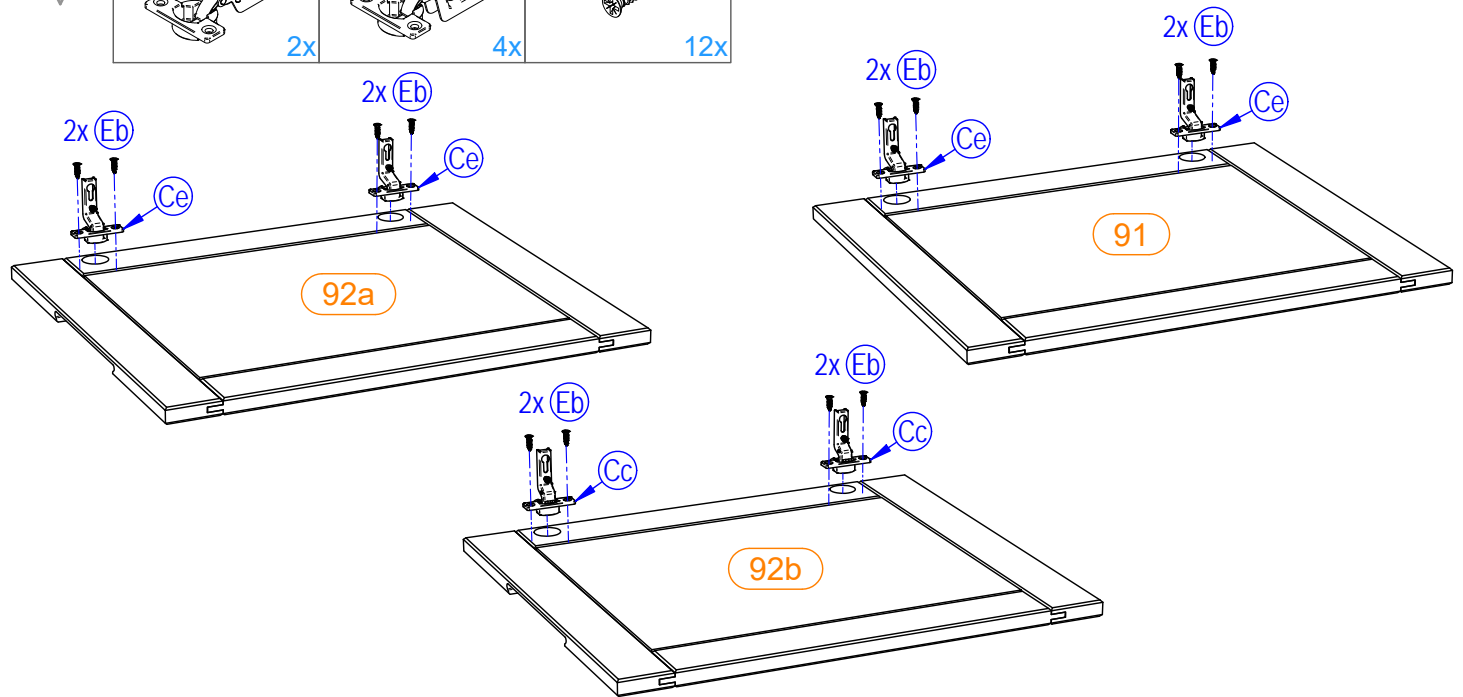

13

D

M4x10



6x

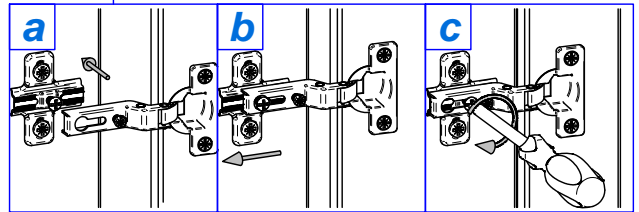
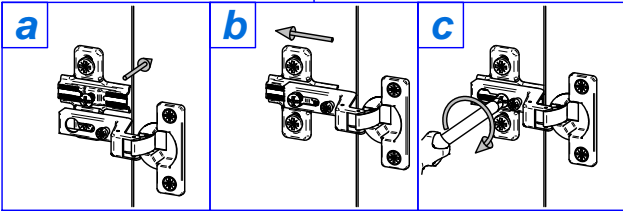
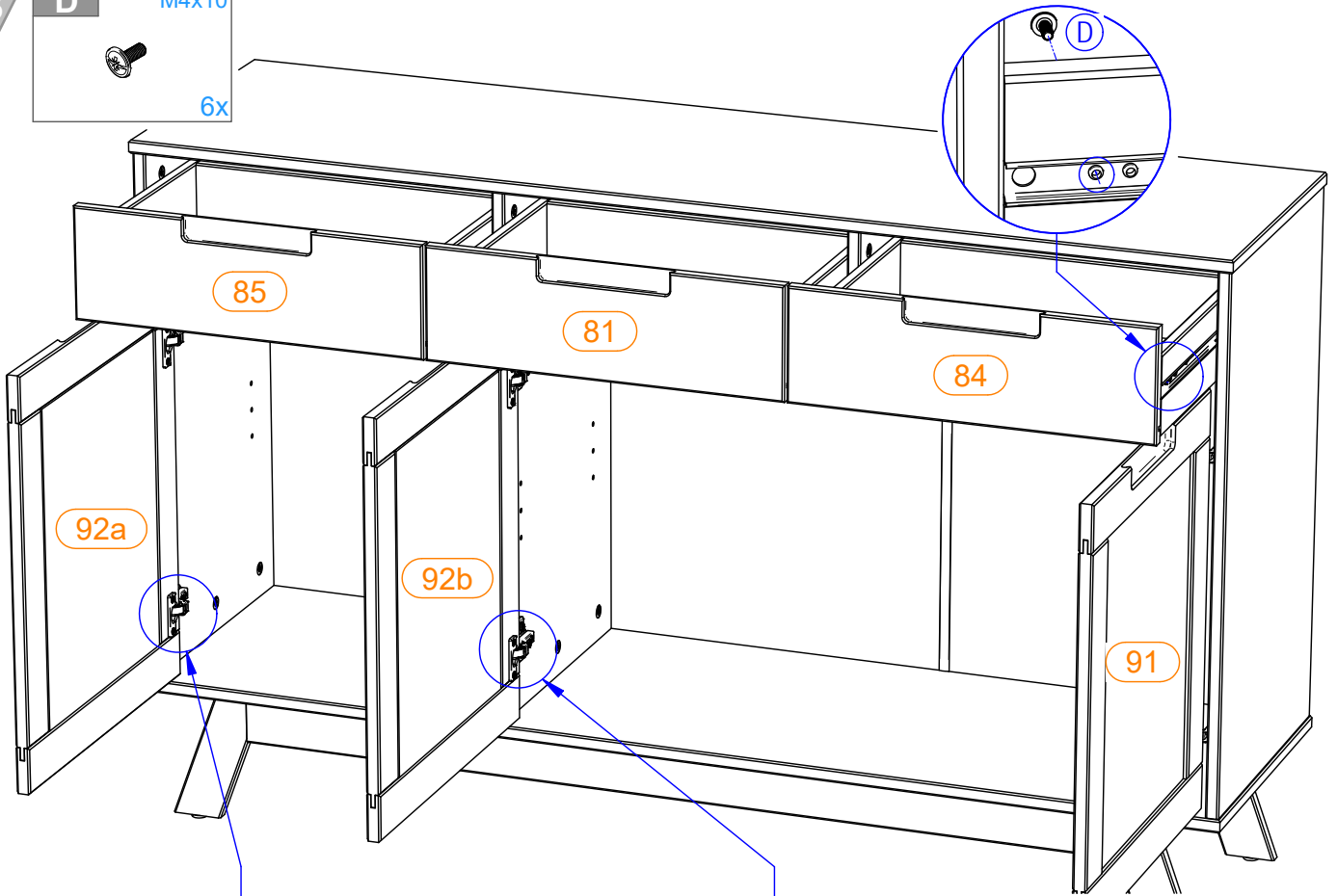

14

N

Ø5/Ø5



8x

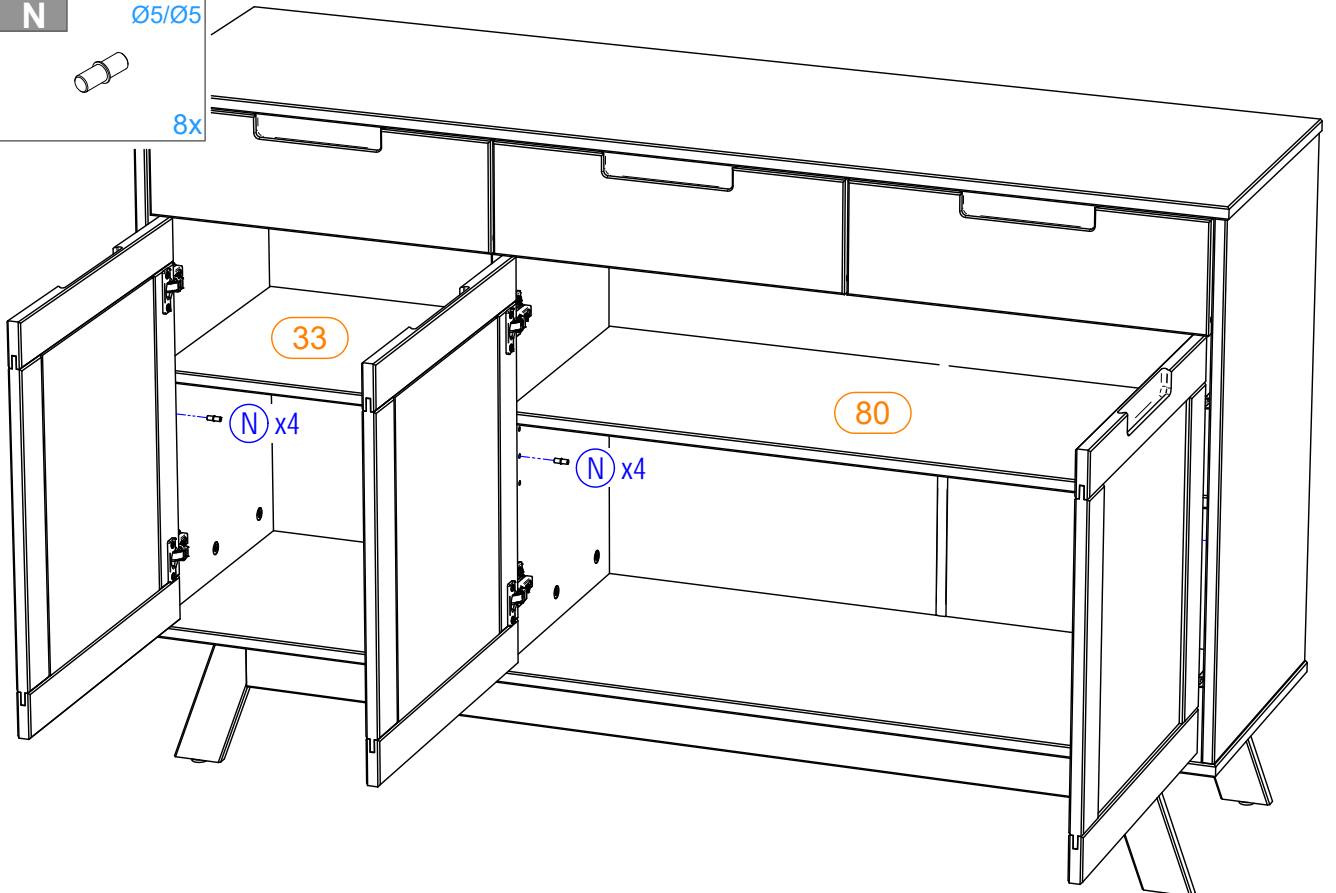

Achtung • Attention • Attenzione • Opgelet • Uwaga • Pozor • Figyelem • Atenție • Dikkat • Внимание	
(D) Türen einstellen (Scharniere justieren)	(FR) Régler les portes (ajuster les charnières)
(GB) Adjusting the doors (adjusting the hinges)	(IT) Sistemare le porte (regolare le cerniere)
(NL) Deuren instellen (scharnieren afstellen)	(CZ) Vyrovnajte dvířka (seříd'te závěsy)
(PL) Nastawić drzwi (wyrównać zawiasy)	(SK) Nastavenie dverí (nastavenie závesov)
(TR) Kapıların ayarlanması (menteşelerin seviye ayarı)	(HU) Állítsa be az ajtókat (állítsa be a zsanérokot)
(RU) Регулировка дверей (регулировка шарнира)	(RO) Reglare ușii (ajustare balamale)

15

