

Modell: CITY / GIRON 24

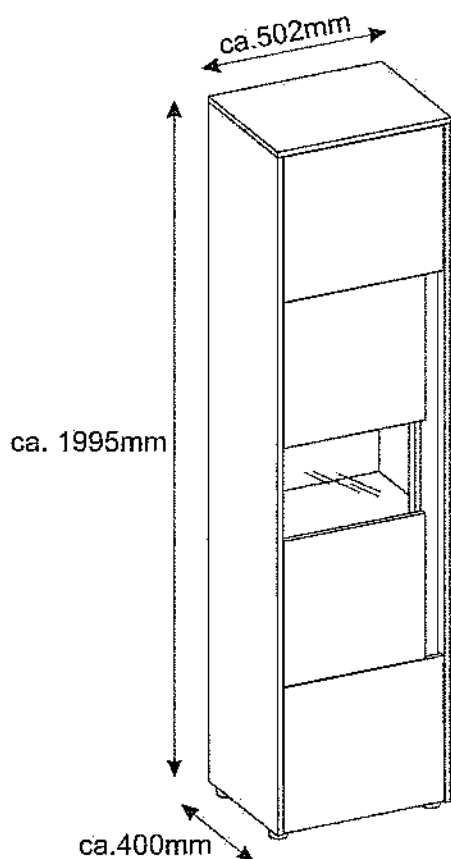

- Ⓛ Montageanleitung
- ⓃL Handleiding voor de montage
- ⓂR Montaj talimatı
- Ⓛ Notice de montage
- ⓃZ Montážní návod
- ⓂU Szerelési útmutató
- ⓂB Assembly Instructions
- Ⓛ Instrukcja montażu
- ⓂU Инструкция по монтажу
- ⓂT Istruzioni di montaggio
- ⓂK Návod na montáž
- ⓂO Instrucțiunile de montaj
- ⓂS Instrucciones de montaje
- ⓂR Montaj Talimatı

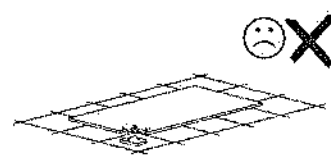

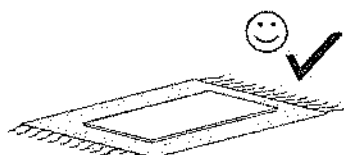
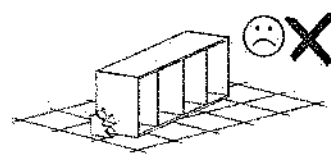
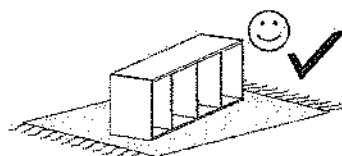
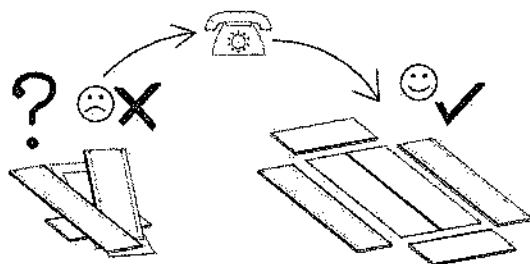
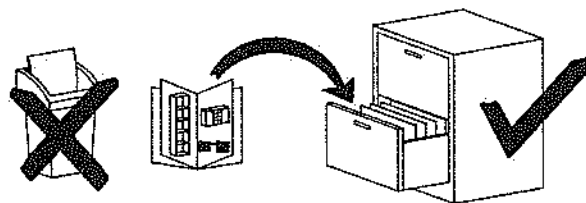
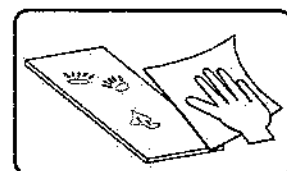
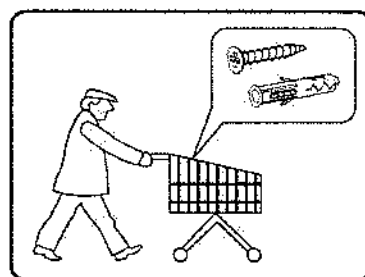
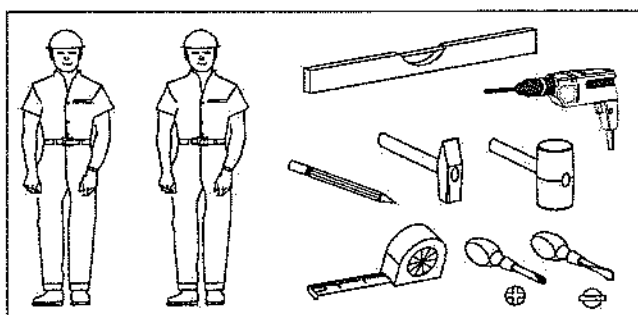



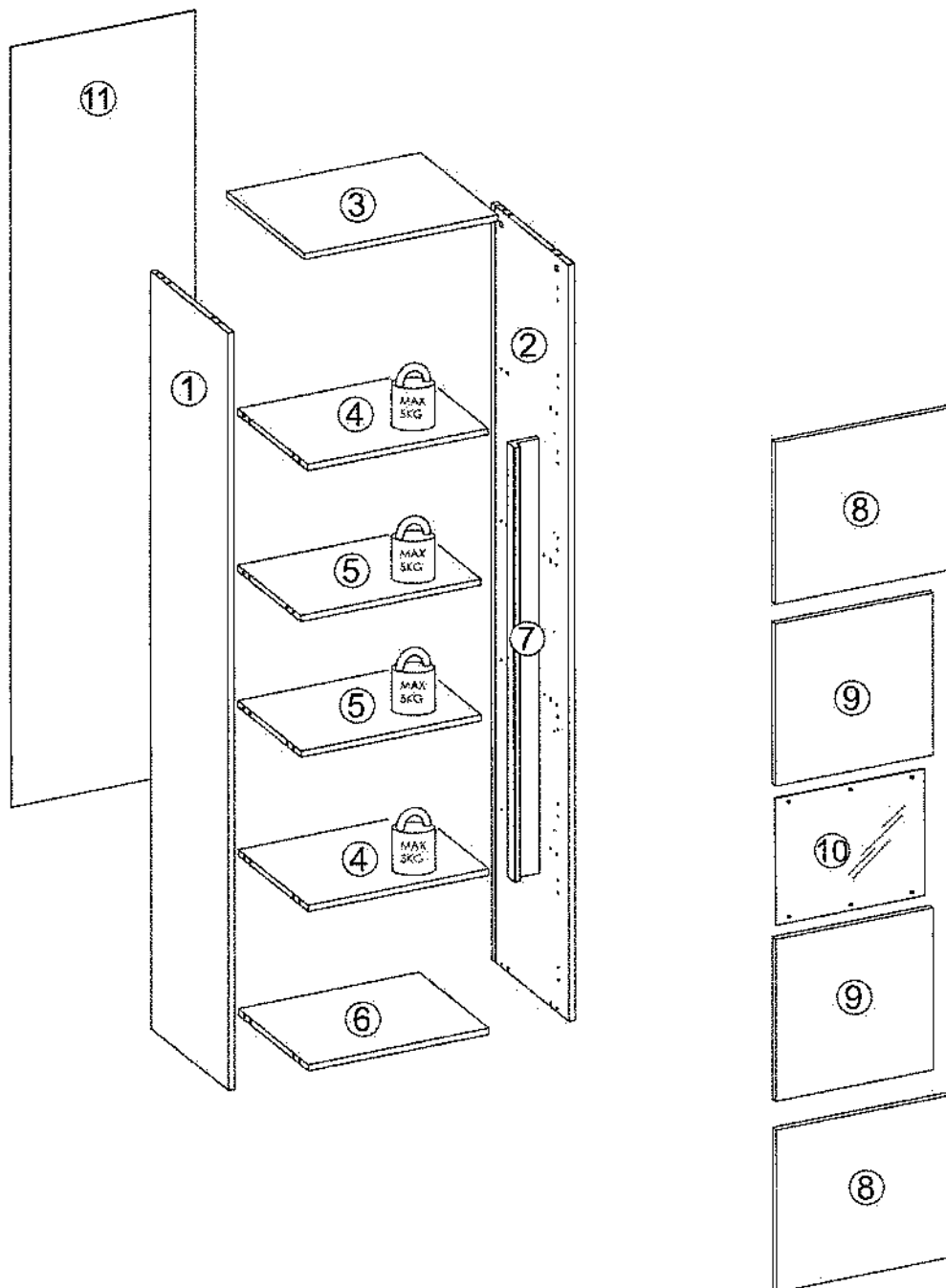

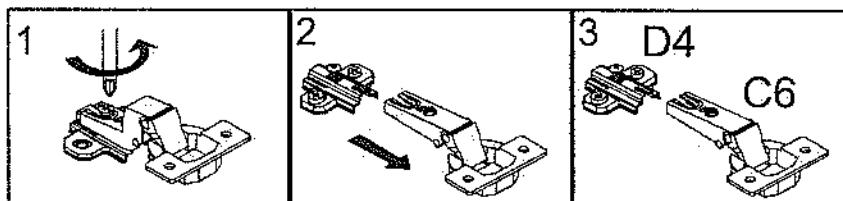
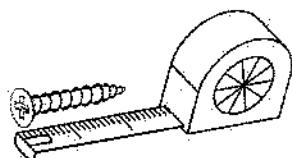
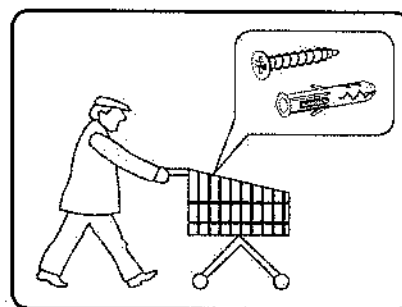
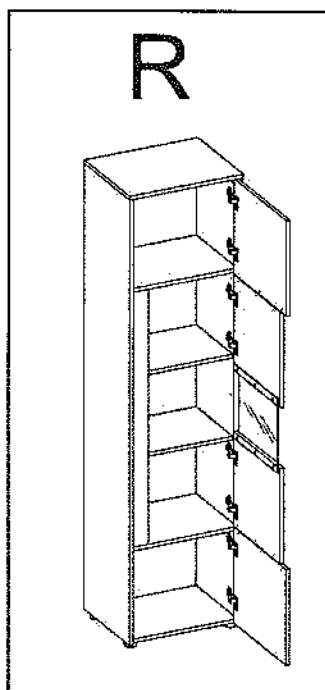
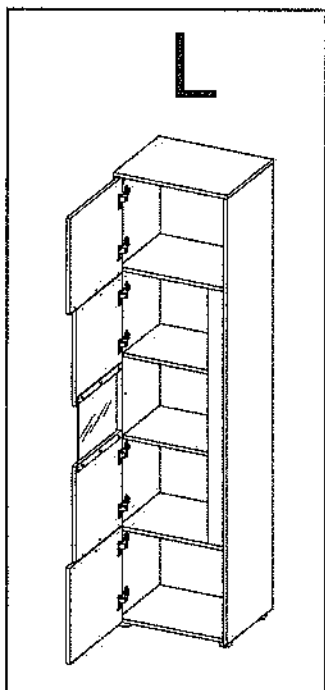
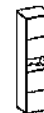







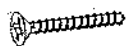

nr	L[mm]	B[mm]	T[mm]	Menge	Coil
1	1954	400	16	1	2/2
2	1954	400	16	1	2/2
3	502	401	16	1	1/2
4	468	362	16	2	2/2
5	468	325	16	2	2/2
6	468	362	16	1	1/2
7	1122	77	38	1	2/2
8	419	463	16	2	1/2
9	419	410	16	2	1/2
10	328	387	4	1	2/2
11	1963	478	3	1	2/2

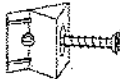



B1  ø8x35 x24	I7  x20	K1  x24	K10  x24	D4  x8
C6  x8	G36  4x30 x4	G34  3,5x16 x17	G49  4x16 x16	F13  x5
I1  x9	M11  x1	G50  3x20 x12	P10  x4	F20  x6

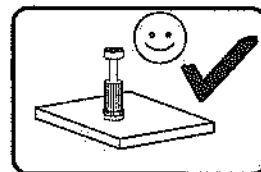
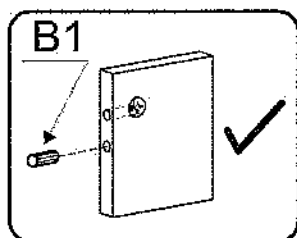
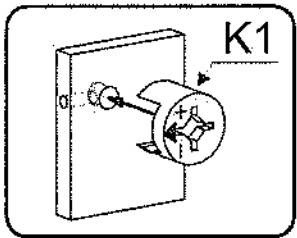
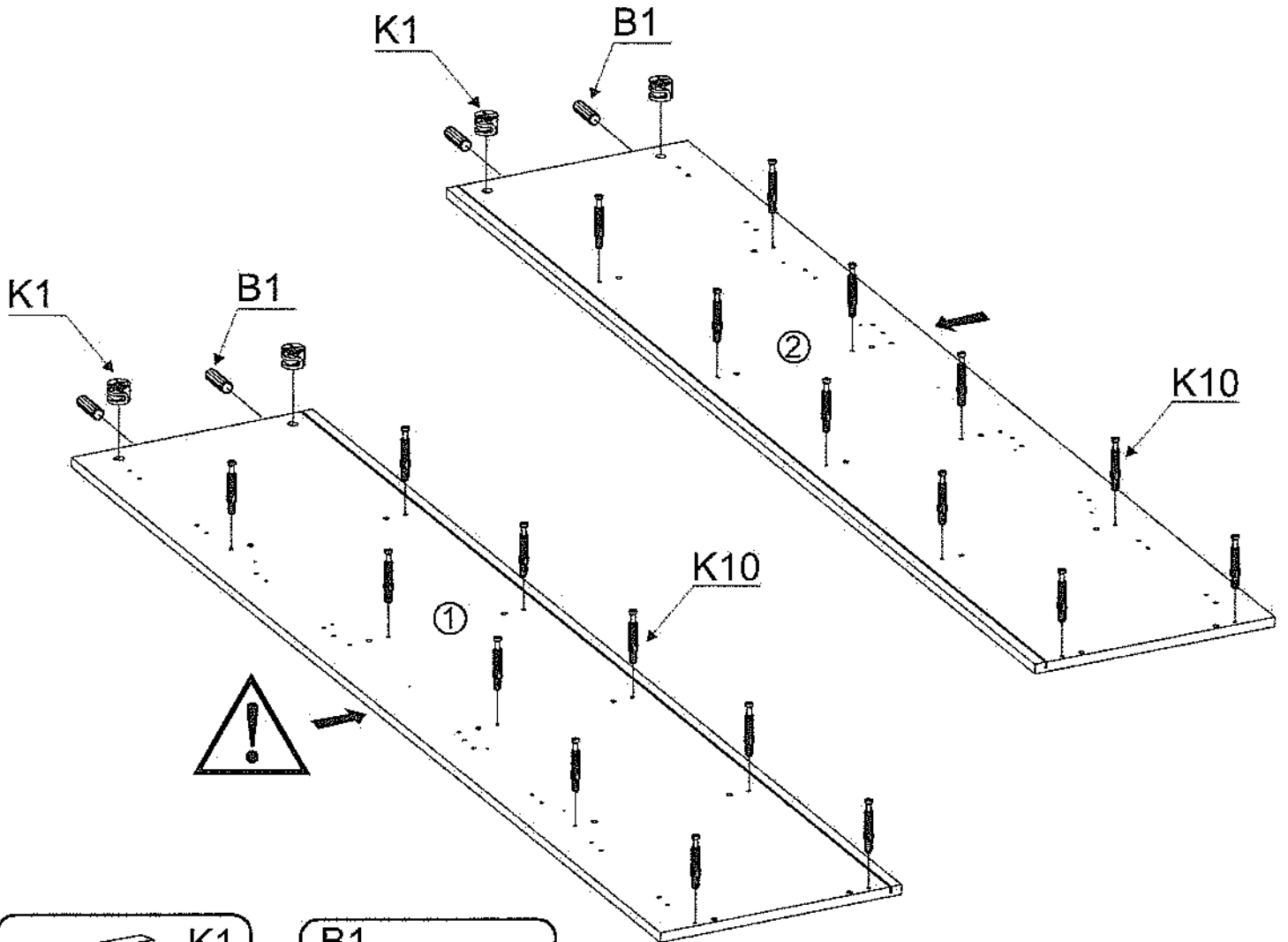
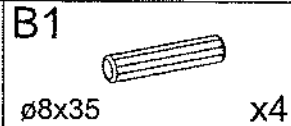
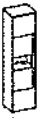

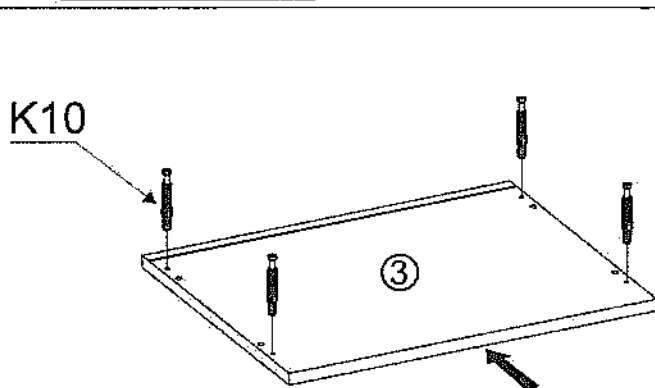

II

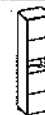



III

B1  $\varnothing 8 \times 35$ x20

K1  x20

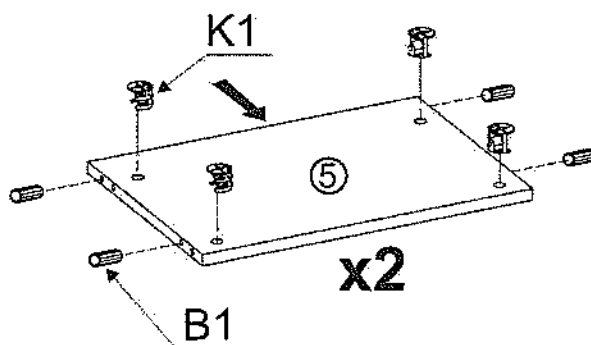
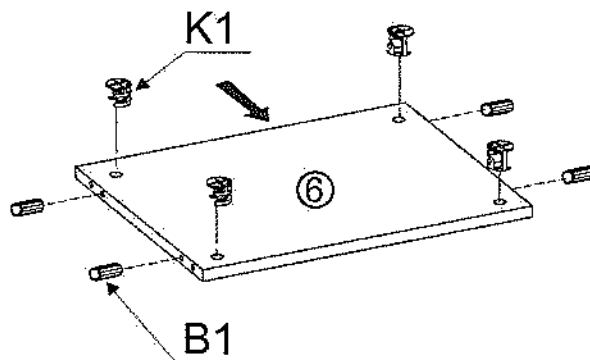
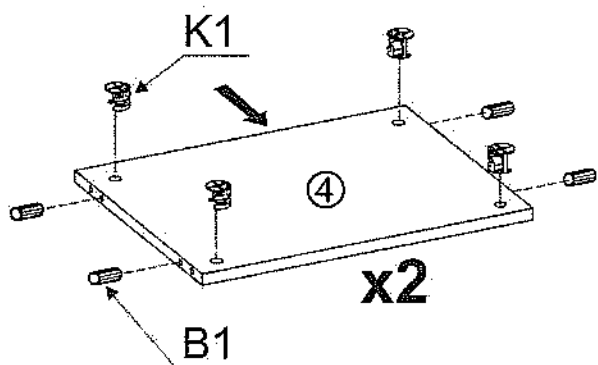

IV

F13  x5

G49  x5
4x16

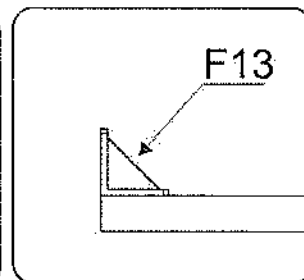
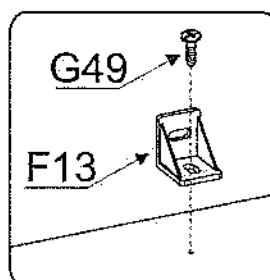
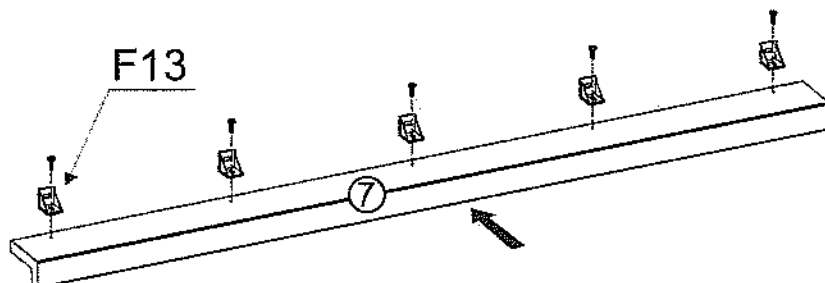



V

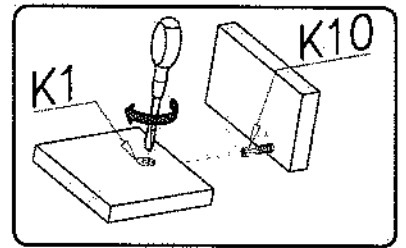
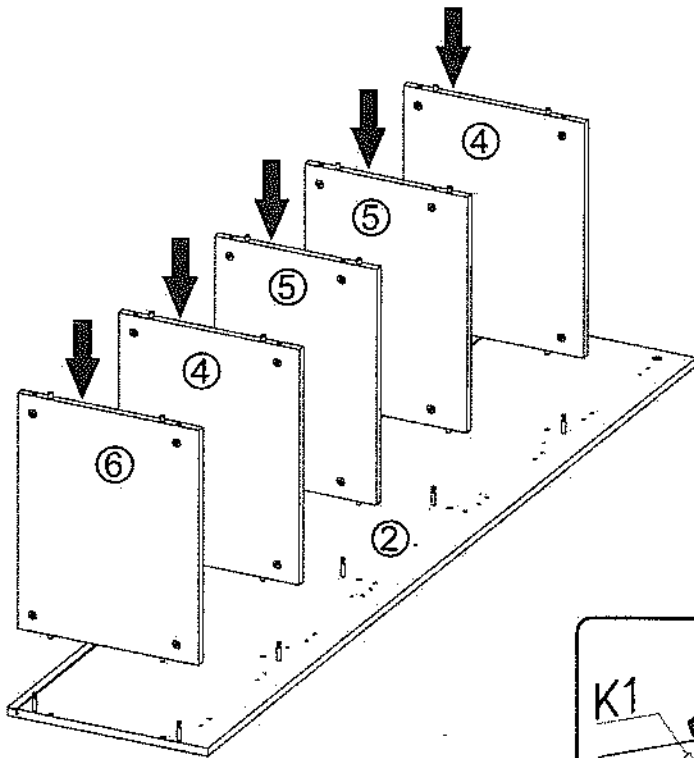
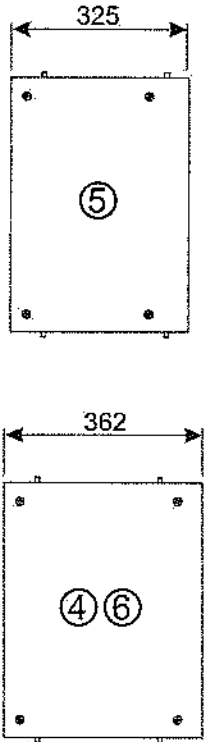

VI

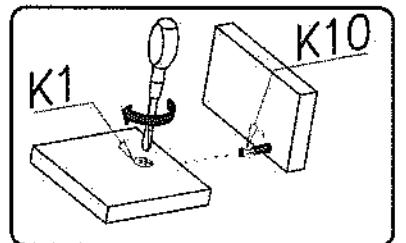
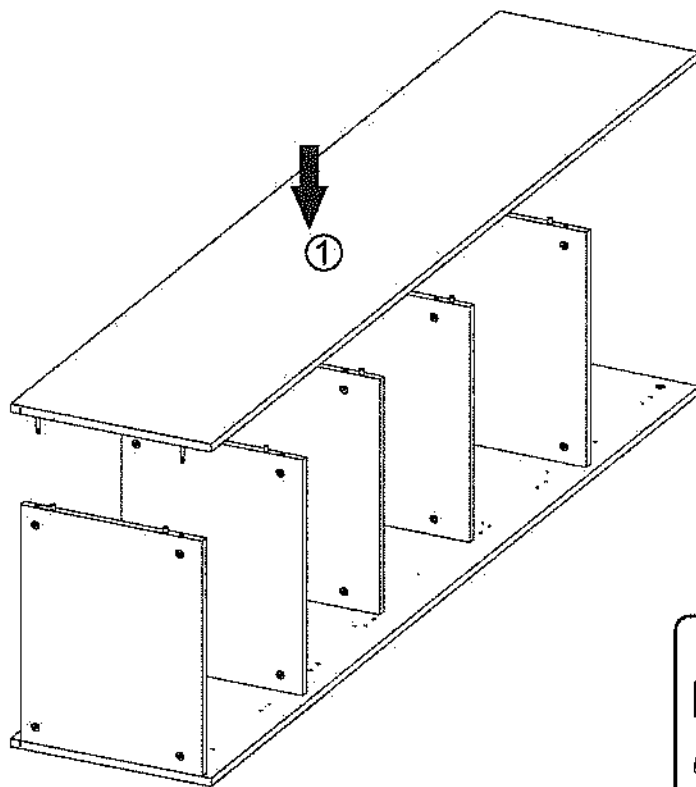

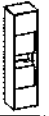

VII

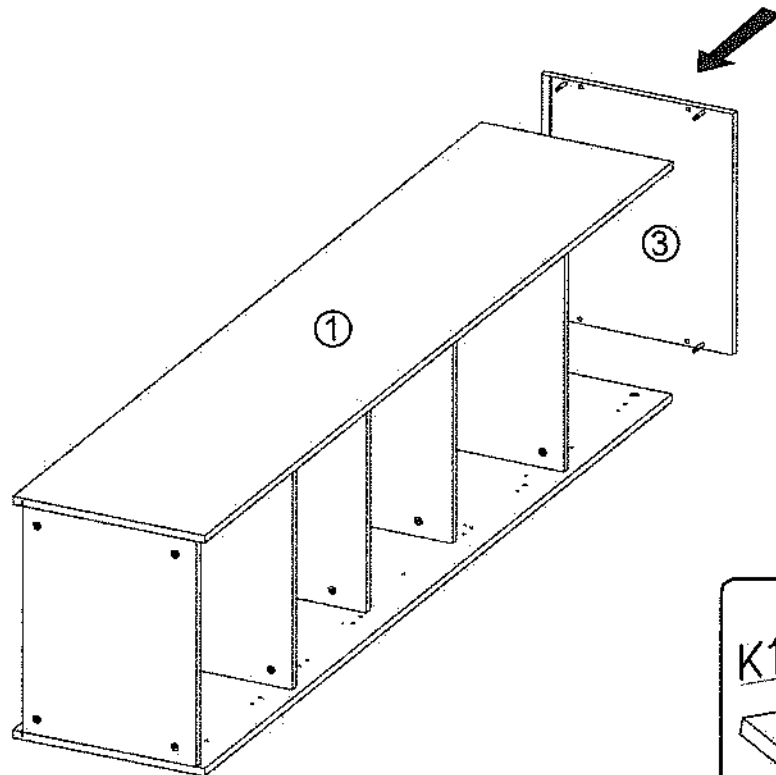

VIII

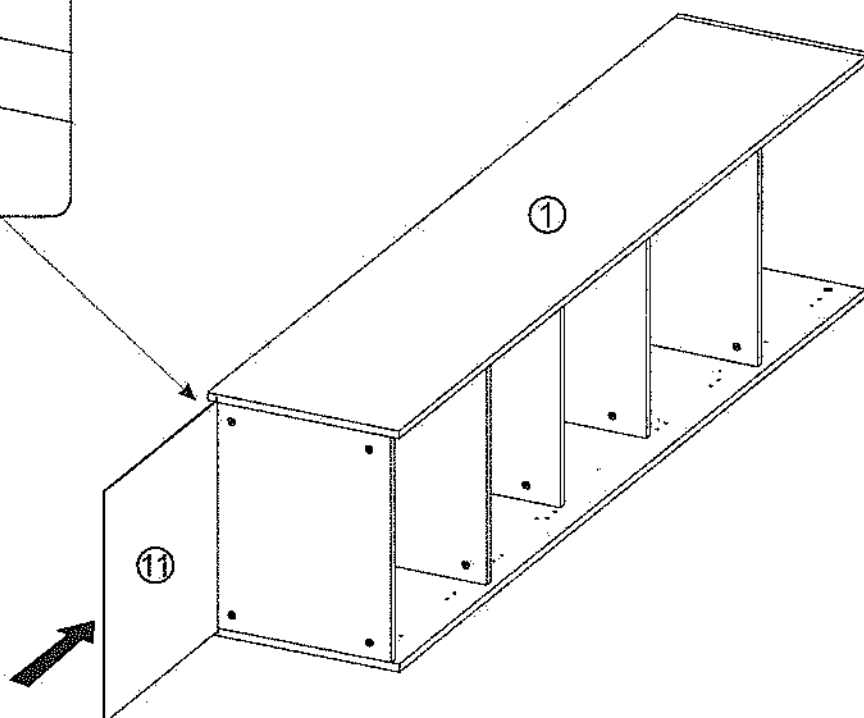
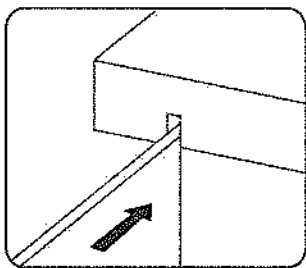

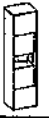

IX

G50

3x20



x12

I1

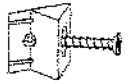

x9

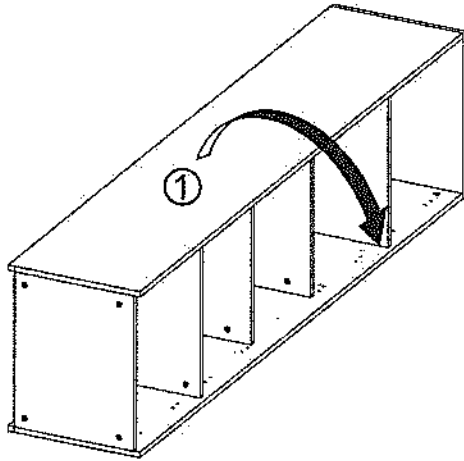

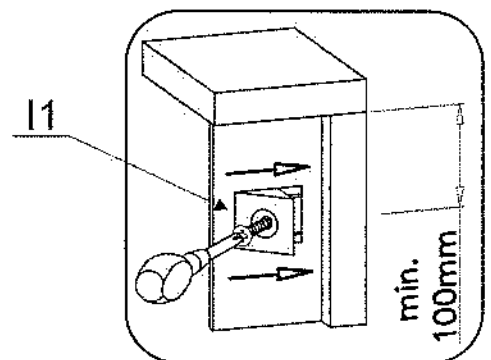
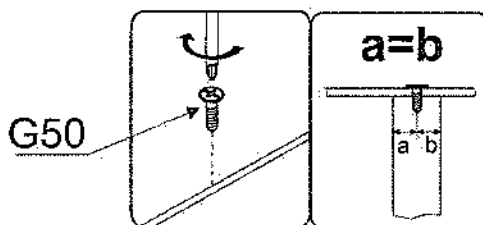
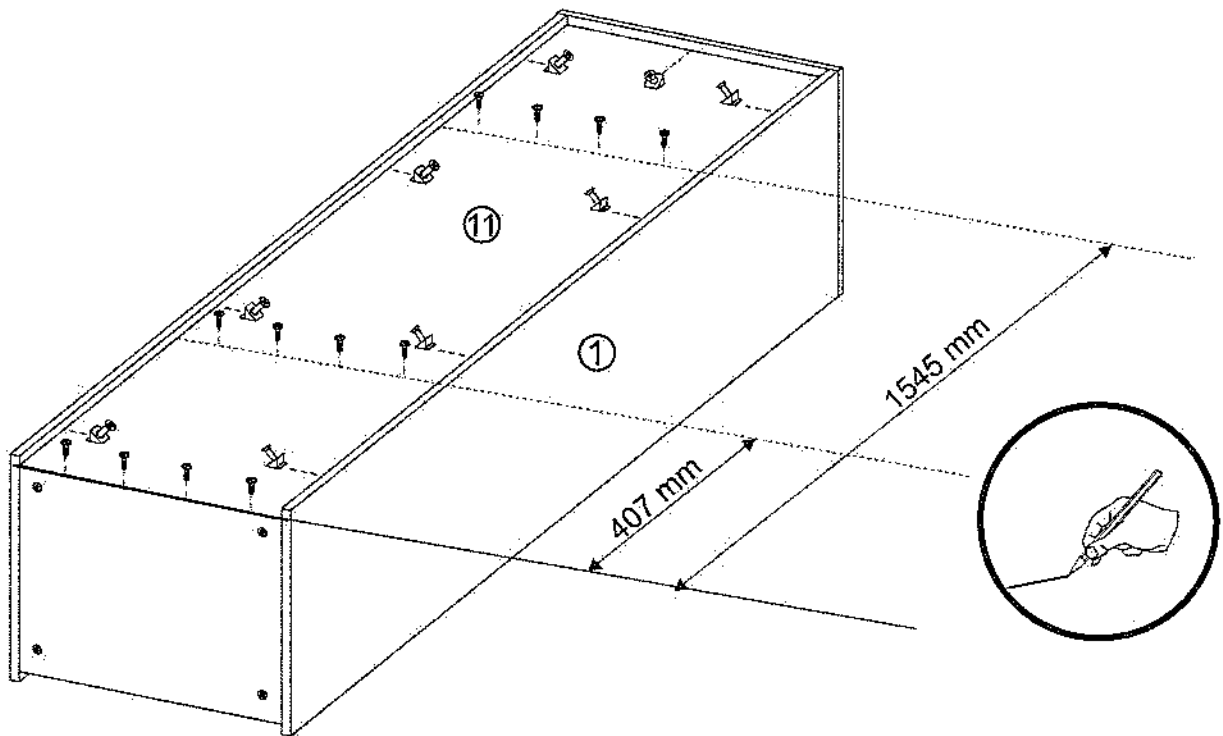
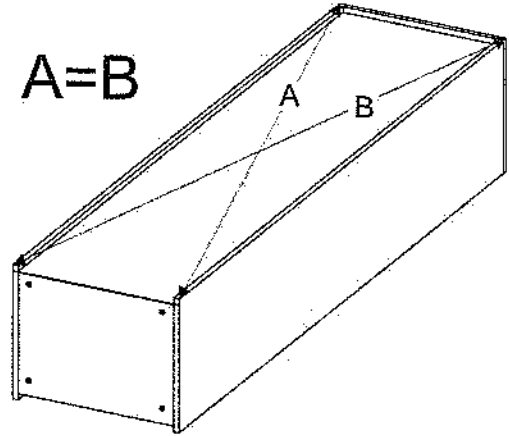

A=B

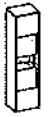

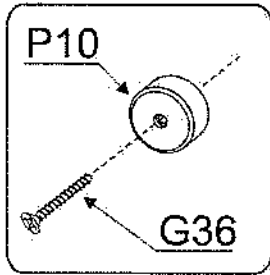

X

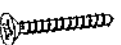

P10		x4
G36		x4
4x30		

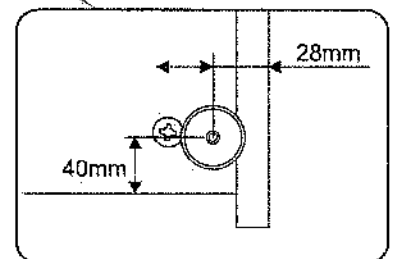
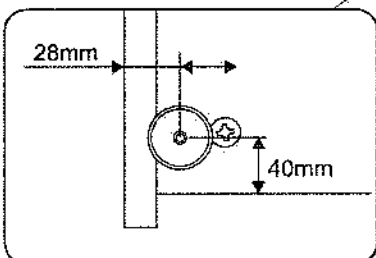
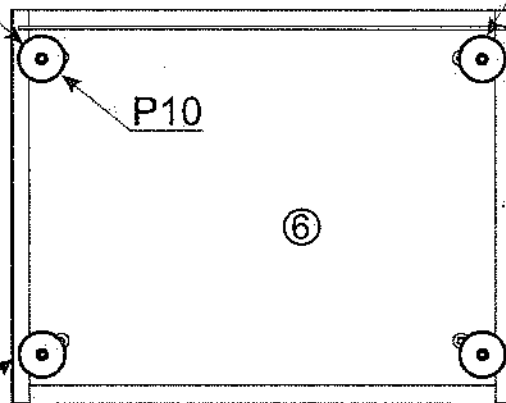
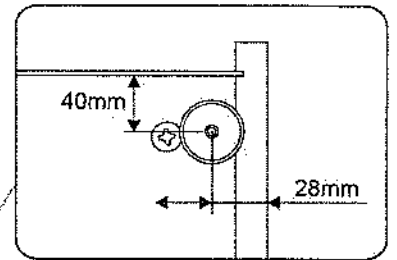
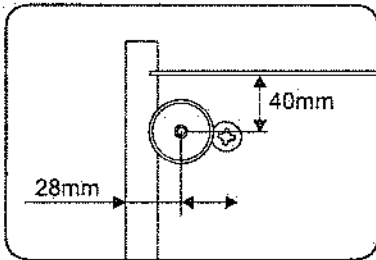
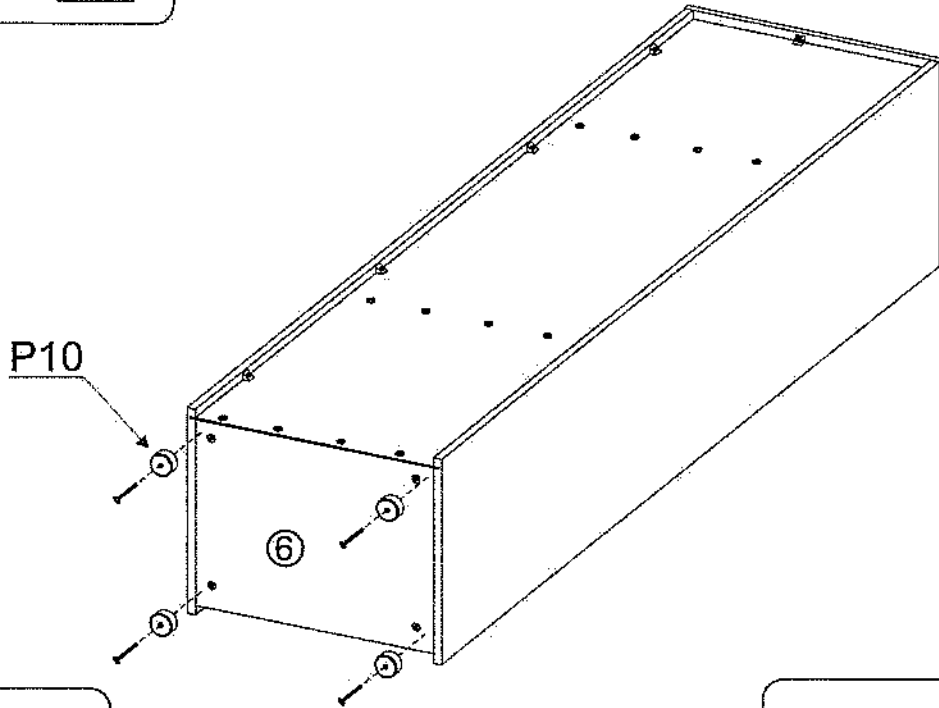



XI

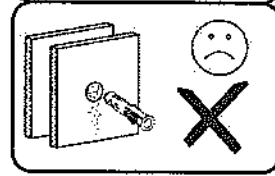
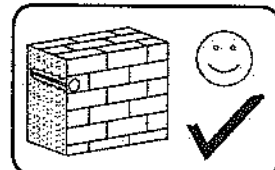
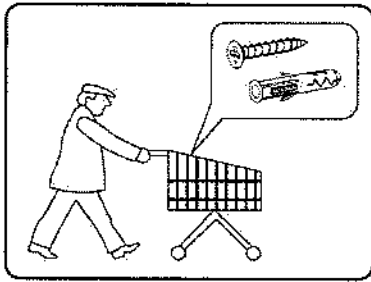

G34



3,5x16

x1

M11

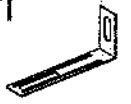

x1

I7



x20

M11

M11

G34

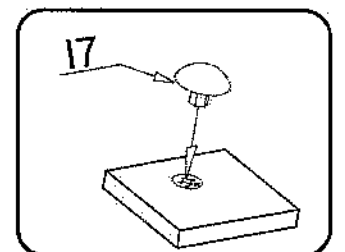
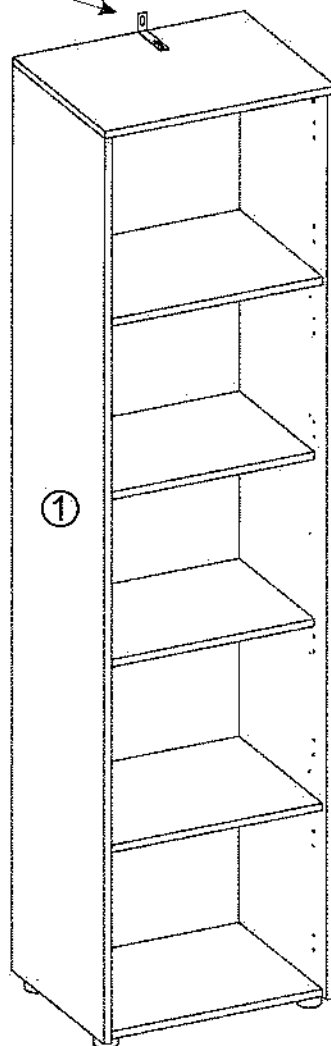
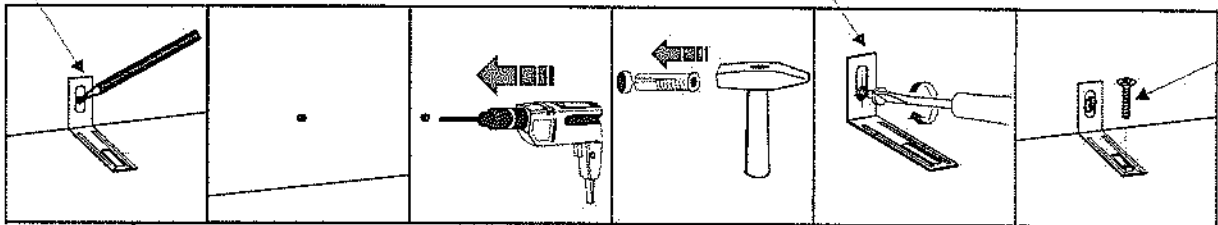

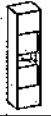

XII

F20



x6

G49



4x16

x6

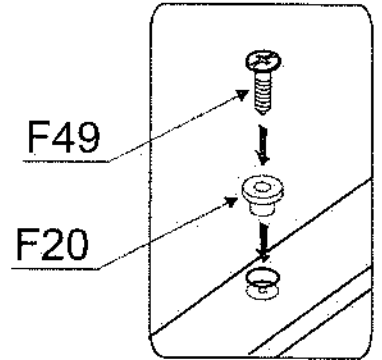
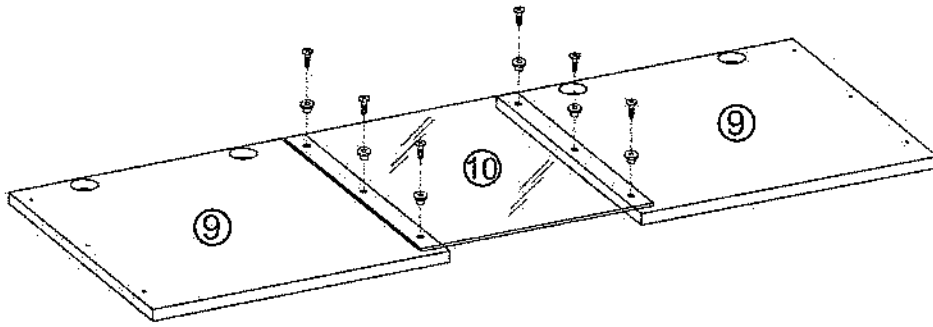

XIII

C6

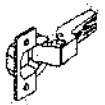

x8

G34



3,5x16

x16

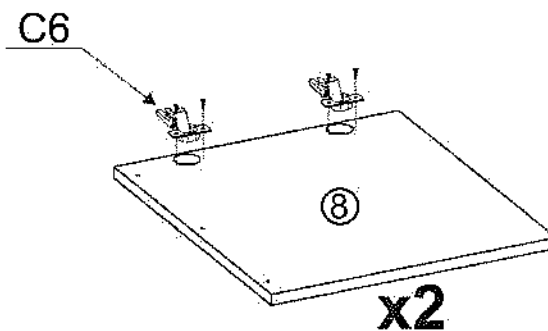
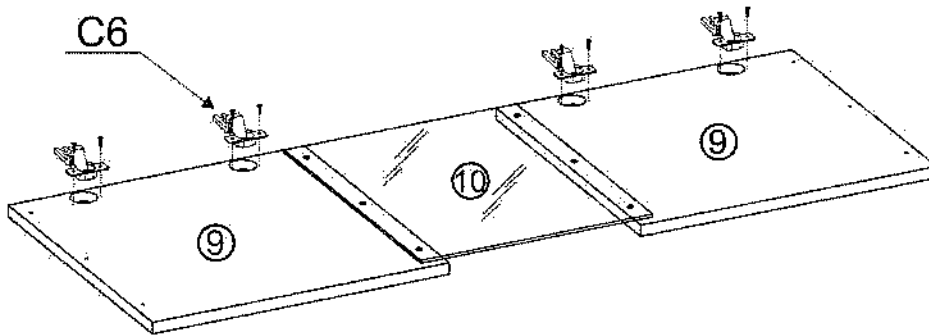

x2

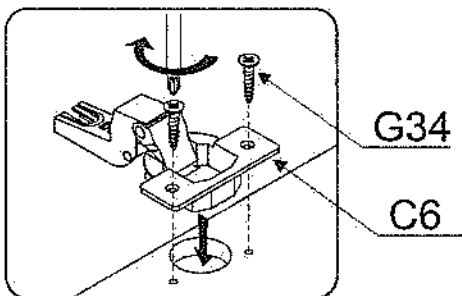



XIV

G49

4x16



x5

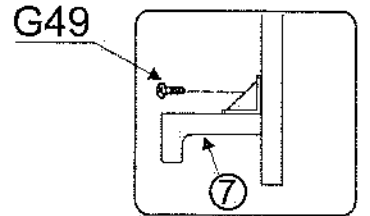
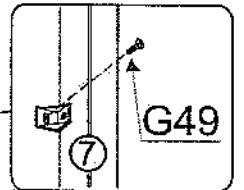
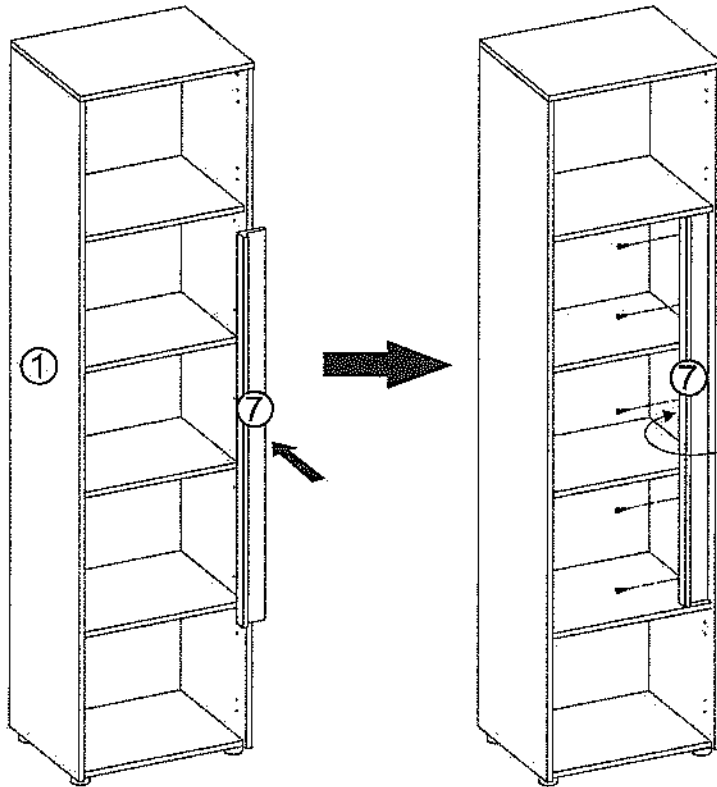
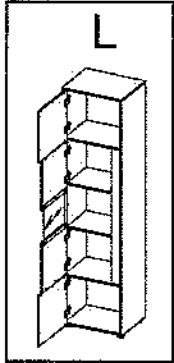

G49

4x16



x5

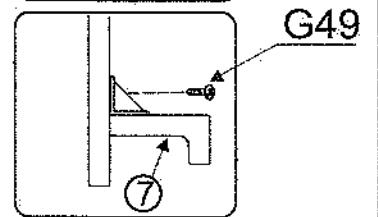
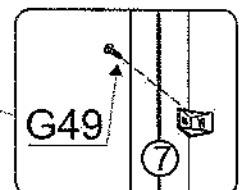
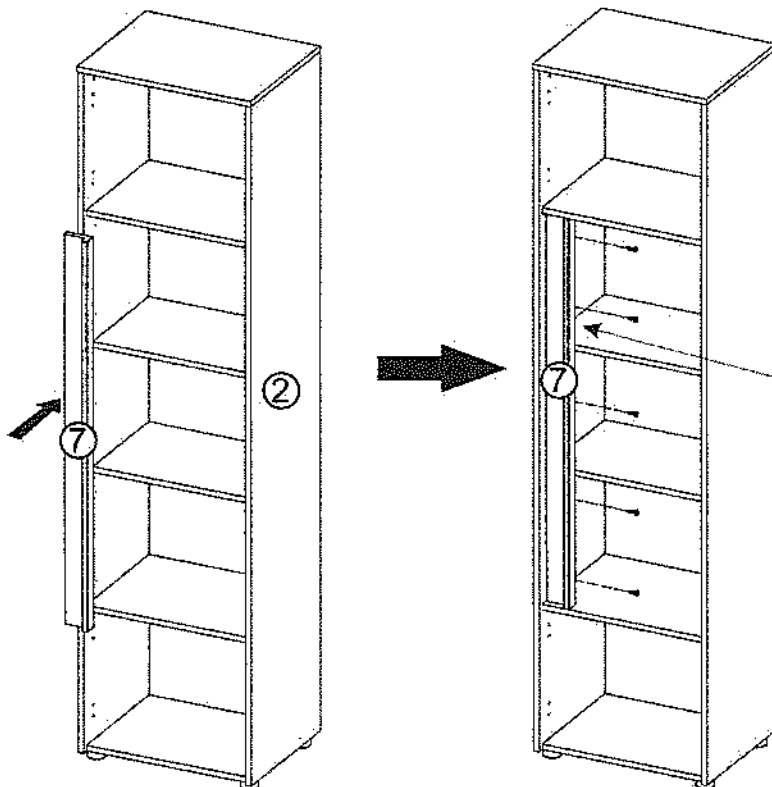
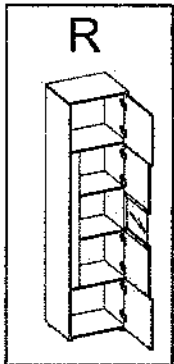



XV

D4



x8

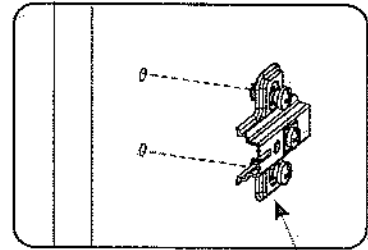
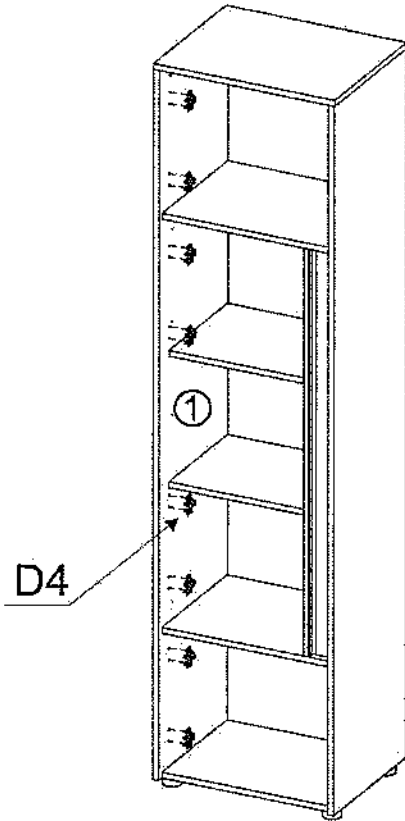
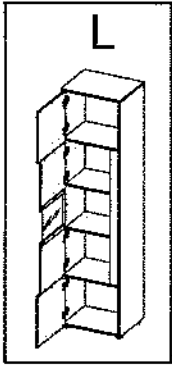

D4

D4



x8

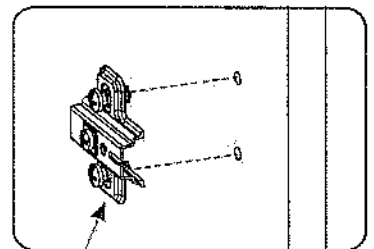
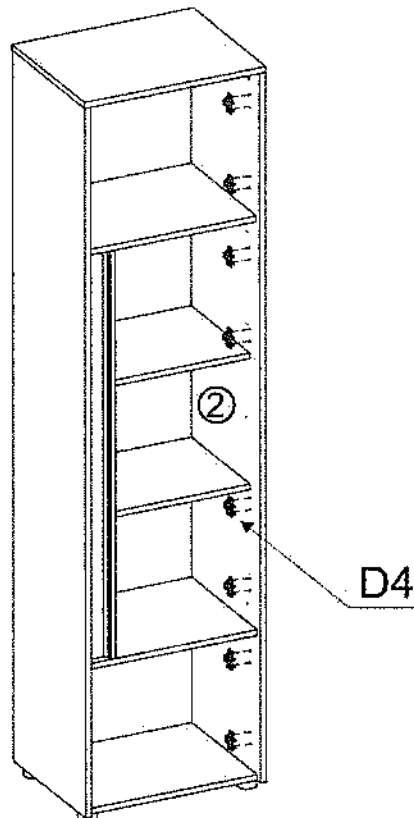
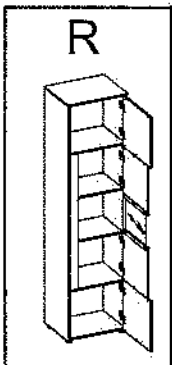

D4

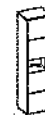

XVI

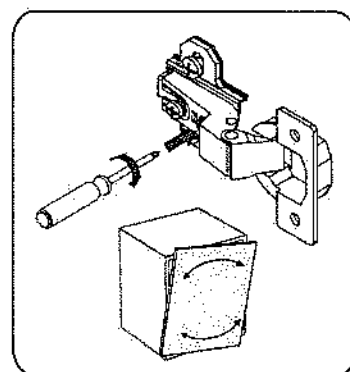
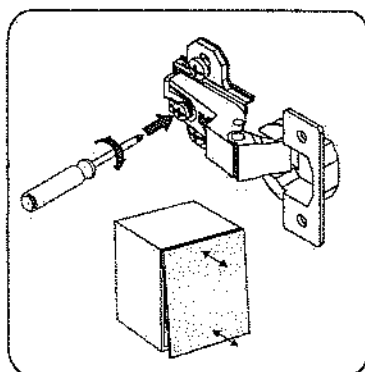
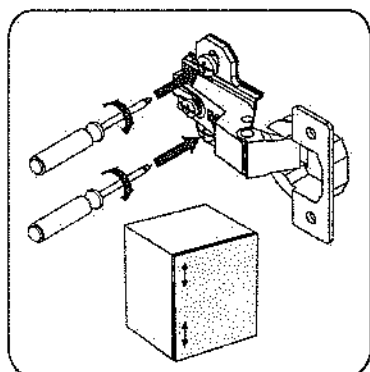
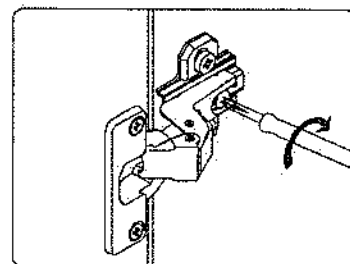
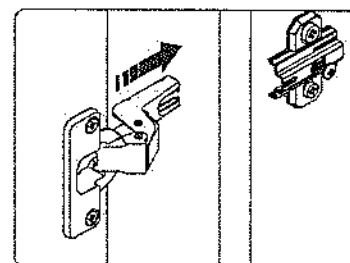
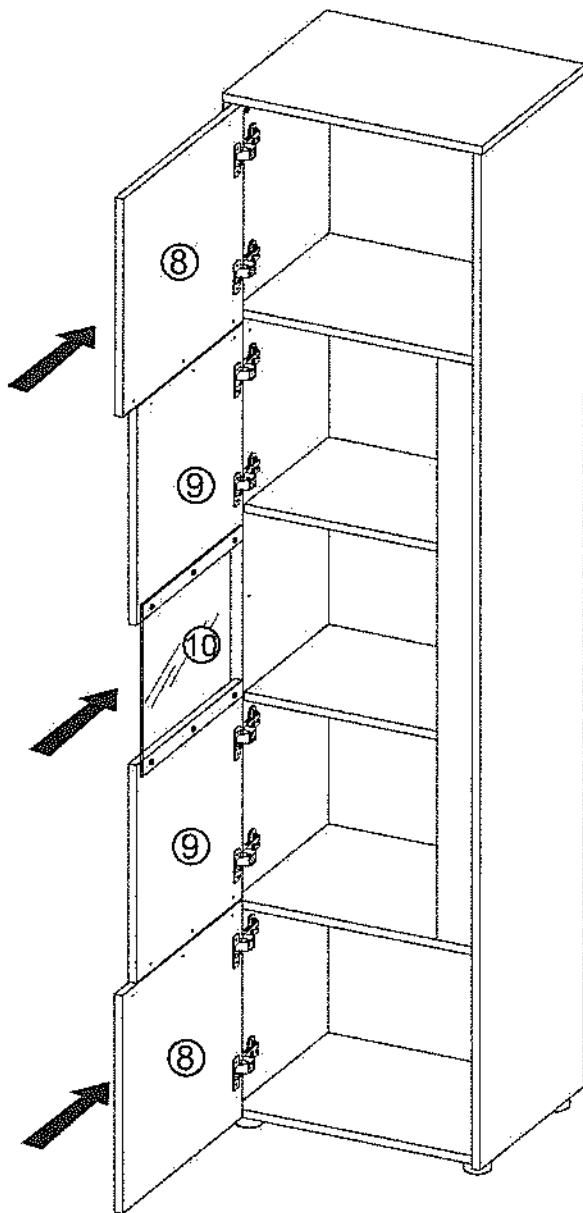
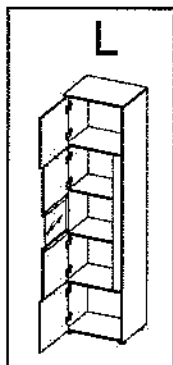

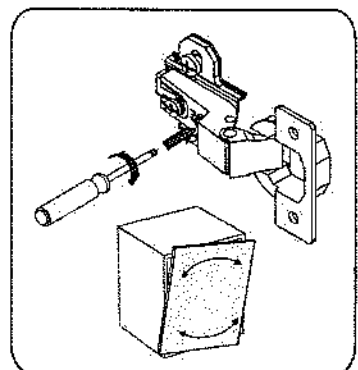
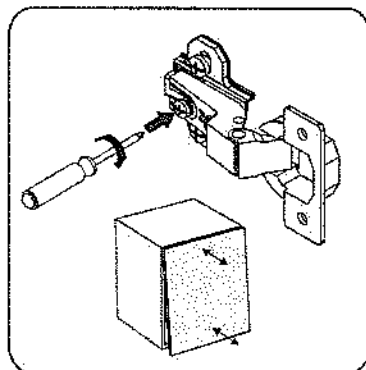
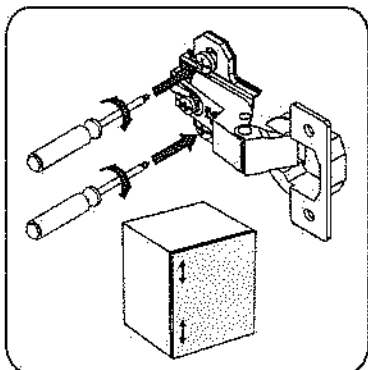
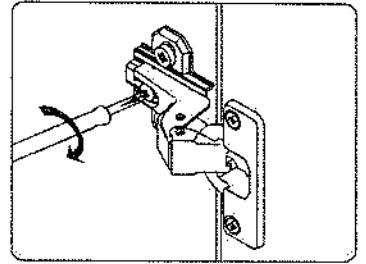
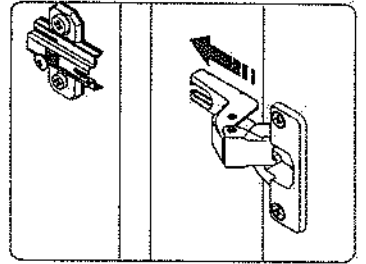
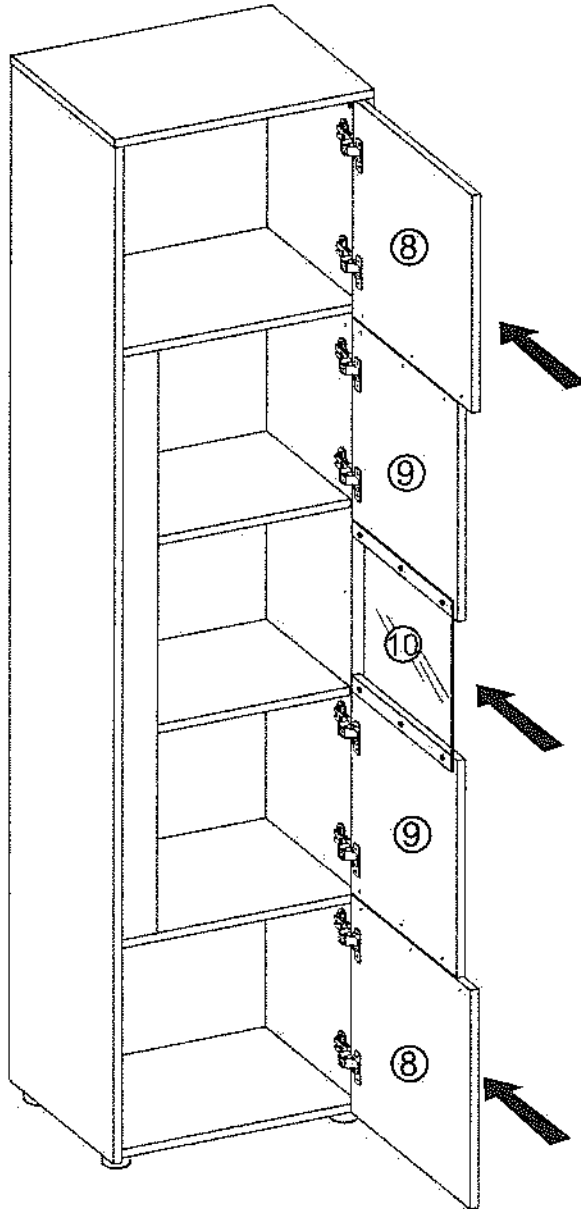
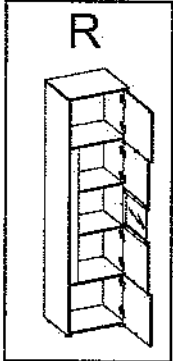

Name • Nom • Nome • Naam • Nazwa • Jméno
• Názov • Név • Denumire • Isim • Имя

Nr • No • N° • Номер • Č • Sz

Typ • Type • Tip • Тípus • Тип • Tun

CITY / GIRON

— —

24

Unser Direktservice für Beschlagteile

Sollte Ihnen ein Beschlagteil fehlen, können Sie diese Servicekarte direkt an die untenstehende Adresse mailen. Wir können allerdings nur Beschlagteile auf diesem Wege verschicken. Sollten Sie eine andere Beanstandung an Ihrem Möbelstück haben, so wenden sie sich bitte direkt an Ihr Möbelhaus.

Our direct order service for fitting

If a fitting part is missing, you can e-mail this service card directly to the address below. However, we can only send fitting parts in this way. If you have any other cause for complaint concerning your item of furniture, please contact your furniture store directly.

Naše online služba pro kování

Chybí-li vám nějaký díl z kování, můžete tuto servisní kartu odeslat e-mailem přímo na níže uvedenou adresu. Touto cestou však můžeme rozesílat jen díly kování. Pokud byste reklamovali jiný díl nábytku, obraťte se přímo na svého prodejce nábytku.

Bien étudier la notice de montage

Si il vous manque une ferrure, veuillez envoyer directement la présente carte service à l'adresse e-mail indiquée ci-dessous. Cependant, ceci nous permet uniquement d'envoyer des ferrures. Pour tout autre type de réclamation concernant votre meuble, veuillez contacter directement votre magasin d'ameublement.

Il nostro servizio diretto per l'ordine della ferramenta

Qualora Vi dovesse mancare un pezzo di fissaggio, allora Vi preghiamo di inviare questa carta di servizio immediatamente all'indirizzo sottostante. Possiamo inviare i pezzi di fissaggio solamente per mezzo di questo procedimento. Qualora dovete avere qualche altra reclamazione in merito al mobile, allora Vi preghiamo di rivolgerVi direttamente al Vostro Negoziò di mobili.

Нашата директна услуга за обков

Ако липсват части от комплекта, попълнете настоящата сервисна карта и ни я изпратете на e-mail адреса, посочен по-долу. По този начин можем да доставяме само липсващи елементи от обкова. Ако имате друг дефект по мебелите, Ви съветваме да се обърнете към мебелната къща/магазин, от която сте закупили стоката.

Onze directservice voor losse onderdelen

Wanneer er een onderdeel ontbreekt, kunt u deze servicekaart direct aan onderstaand e-mailadres sturen. Wij kunnen langs deze weg echter alleen beslagdelen versturen. Mocht u een ander probleem aan uw meubel hebben, verzoeken wij u contact op te nemen met uw meubeldealer.

Nasz bezpośredni serwis części montażowych

Jeżeli brakuje części koniecznych do montażu, prosimy o przesłanie nam niniejszej karty serwisowej na niżej podany adres e-mailowy. W ten sposób możemy przesyłać Państwu tylko brakujące części. W przypadku innych reklamacji dotyczących mebla, prosimy zgłosić się do salonu meblowego, w którym został dokonany zakup.

Servis za okove

U slučaju da nedostaje neki od dijelova molimo vas da na dole navedenu mail adresu pošaljete ovaj servisni obrazac. Na ovaj način mogu se dostaviti samo okovi. U slučaju da imate dodatne prigovore vezane uz komad namještaja molimo vas da se obratite izravno trgovini namještaja gdje je isti kupljen.

Direktszolgalatunk vasalatok eseten

Ha hiányzik egy vasalat, ezt a kártyát közvetlenül elküldheti az alább található címre. Azonban csak a vasalatokat tudunk így küldeni. Amennyiben másfajta reklamáció áll fenn a bútordarabjait illetően, forduljon közvetlenül a bűtörházhoz.

Naše online servis pro část kování

Ak by Vám chýbala nejaká časť kovania, môžete poslať túto servisnú kartu pošou na nižšie uvedenú adresu. Diely kovania vieme poslať iba týmto spôsobom. Ak by ste mali inú reklamáciu, ohľadom Vášho nábytku, obraťte sa priamo na Vašu predajňu nábytku.

Naše direktne uslužne službe za okovje

Če vam manjka kakšno okovje, lahko to servisno kartico pošljete po e-pošti direktno na spodnji naslov. Po tej poti vam lahko pošljemo samo okovje. Če želite reklamirati kakšen drug del pohištva, se obrnite neposredno na vašo trgovino pohištva.

Service-ul nostru direct pentru feroneria

În cazul în care vă lipsește o piesă de feronerie puteți să trimiteți direct acest card de service prin e-mail la adresa de mai jos. Noi nu putem expedia piese de feronerie decât pe această cale. Dacă aveți o altă reclamație referitoare la piesa de mobilier, atunci vă rugăm să vă adresați direct la magazinul dvs. de mobilă.

Наш прямой сервис для поставок фурнитуры

Если окажется, что Вам не хватает того или иного элемента фурнитуры, Вы можете отправить сервисную карту по факсу непосредственно на нижеприведенный адрес электронной почты. Однако, таким образом мы можем пересылать лишь фурнитуру. Если же у Вас возникнут иные претензии относительно приобретенной мебели, пожалуйста, обращайтесь непосредственно в организацию, осуществляющую продажу.

Vår direktservice för beslagdelar

Om du saknar en beslagsdel kan du skicka detta servicekort direkt till e-postadressen som anges nedan. Tänk på att detta är den enda möjligheten att skicka beslagdelar till dig. Om du vill reklamera ditt möbel av en annan anledning måste du kontakta ditt möbelhus direkt.









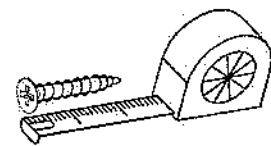

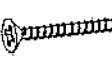

Nuestro servicio directo para accesorios

Si le falta algún accesorio, puede enviar esta tarjeta de servicio directamente a la siguiente dirección. No obstante, por este método solo podemos enviar accesorios. Si tiene alguna otra objeción sobre su mueble, consulte directamente con su mueblería.

Donatilor için doğrudan servisimiz

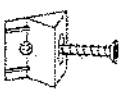
Bir donatınız eksikse bu servis kartını doğrudan aşağıda bulunan adrese doğrudan mail yazabilirsiniz. Sadece bu yolla doğrudan gönderilebilir. Mobilyanızda başka şikayetleriniz varsa diğer doğrudan mobilya satıcılarınıza danışın.



B1 ø8x35 X...	I7  X...	K1  X...
K10  X...	D4  X...	C6  X...
G36  4x30 X...	G34  3,5x16 X...	G49  4x16 X...
F13  X...	I1  X...	M11  X...
G50  3x20 X...	P10  X...	F20  X...

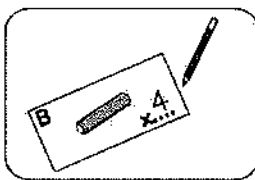

Name • Nom • Nome • Naam • Nazwa • Jméno
• Názov • Név • Denumire • İsim • Имя

Nr • No • N° • Номер • Č • Sz

Typ • Type • Tip • Típus • Tipo • Tun

CITY / GIRON

— —

24

Unser Direktservice für Beschädigte

Sollte Ihnen ein Beschädigtes fehlen, können Sie diese Servicekarte direkt an die untenstehende Adresse mailen. Wir können allerdings nur Beschädigte auf diesem Wege verschicken. Sollten Sie eine andere Beanstandung an Ihrem Möbelstück haben, so wenden Sie sich bitte direkt an Ihr Möbelhaus.

Our direct order service for fitting

If a fitting part is missing, you can e-mail this service card directly to the address below. However, we can only send fitting parts in this way. If you have any other cause for complaint concerning your item of furniture, please contact your furniture store directly.

Náše přímé služby pro kování

Čtyřlístí vám nějaký díl z kování, můžete tuto servisní kartu odeslat e-mailem přímo na níže uvedenou adresu. Touto cestou však můžeme rozesílat jen díly kování. Pokud byste reklamovali jiný díl nábytku, obraťte se přímo na svého prodejce nábytku.

Bien étudier la notice de montage

Si l'un vous manque une ferrure, veuillez envoyer directement la présente carte service à l'adresse e-mail indiquée ci-dessous. Cependant, ceci nous permet uniquement d'envoyer des ferrures. Pour tout autre type de réclamation concernant votre meuble, veuillez contacter directement votre magasin d'aménagement.

Il nostro servizio diretto per l'ordine della ferramenta

Qualora Vi dovesse mancare un pezzo di fissaggio, allora Vi preghiamo di inviare questa carta di servizio immediatamente all'indirizzo sottostante. Possiamo inviare i pezzi di fissaggio solamente per mezzo di questo procedimento. Qualora dovete avere qualche altra reclamazione in merito al mobile, allora Vi preghiamo di rivolgerVi direttamente al Vostro Negozio di mobili.

Нашата директна услуга за обков

Ако липневат части от комплекта, попълнете настоящата сервисна карта и ни я изпратете на e-mail адреса, посочен по-долу. По този начин можем да доставяме само липсващи елементи от обкова. Ако установите други дефекти по мебелите, Ви съветваме да се обърнете към мебелната къща/магазин, от който сте закупили стоката.

Onze directservice voor losse onderdelen

Wanneer er een onderdeel ontbreekt, kunt u deze servicekaart direct aan onderstaand e-mailadres sturen. Wij kunnen langs deze weg echter alleen beslagdelen versturen. Mocht u een ander probleem aan uw meubel hebben, verzoeken wij u contact op te nemen met uw meubeldealer.

Nasz bezpośredni serwis części montażowych

Jeżeli brakuje części koniecznych do montażu, prosimy o przesłanie nam niniejszej karty serwisowej na niżej podany adres e-mailowy. W ten sposób możemy przesyłać Państwu tylko brakujące części. W przypadku innych reklamacji dotyczących mebla, prosimy zgłosić się do salonu meblowego, w którym został dokonany zakup.

Servis za okove

U slučaju da nedostaje neki od dijelova molimo vas da na dole navedenu mail adresu pošaljete ovaj servisni obrazac. Na ovaj način mogu se dostaviti samo okovi. U slučaju da imate dodatne prigovore vezane uz komad namještaja molimo vas da se obraćate izravno trgovini namještaja gdje je isti kupljen.

Direktszolnalatunk vasalatok esetén

Ha hiányzik egy vasalat, ezt a kártyát közvetlenül elküldheti az alábbi található címre. Azonban csak vasalatoskat tudunk így küldeni. Amennyiben másfajta reklamáció áll fenn bültördarabját illetően, forduljon közvetlenül a boltiáruházhoz.

Náš priamy servis pre časti kovania

Ak by Vám chýbala niekaka časť kovania, môžete poslať túto servisnú kartu pošťou e-mailom na nižšie uvedenú adresu. Diely kovania vieme poslať iba týmto spôsobom. Ak by ste mali inú reklamáciu ohľadom Vášho nábytku, obráťte sa priamo na Vašu predajňu nábytku.

Náše direktno službene storitve za okovje

Če vam manjka kakšno okovje, lahko to servisno kartico pošljete po e-pošti direktno na spodnji naslov. Po tej poti vam lahko pošljemo samo okovje. Če želite reklamirati kakšen drug del pohištva, se običito neposredno na vašo trgovino pohištva.

Service-ul nostru direct pentru feronerie

În cazul în care vă lipsește o piesă de feronerie puteți să trimiteți direct acest card de service prin e-mail la adresa de mai jos. Noi nu putem expedia piese de feronerie decât pe această cale. Dacă aveți o altă reclamație referitoare la piesa de mobilier, atunci vă rugăm să vă adresați direct la magazinul dvs. de mobilă.

Наш прямой сервис для поставок фурнитуры

Если окажется, что Вам не хватает той или иного элемента фурнитуры, Вы можете отправить сервисную карту по факсу непосредственно на нижеприведенный адрес электронной почты. Однако, таким образом мы можем пересылать лишь фурнитуру. Если же у Вас возникнут иные претензии относительно приобретенной мебели, пожалуйста, обращайтесь непосредственно в организацию, осуществляющую продажу.

Vår direktservice för beslagdelar

Om du saknar en beslagsdel kan du skicka detta servicekort direkt till e-postadressen som anges nedan. Tenk på att detta är den enda möjligheten att skicka beslagdelar till dig. Om du vill reklamera din möbel av en annan anledning måste du kontakta ditt möbelhus direkt.

Nuestro servicio directo para accesorios

Si le falta algún accesorio, puede enviar esta tarjeta de servicio directamente a la siguiente dirección. No obstante, por este método solo podemos enviar accesorios. Si tiene alguna otra objeción sobre su mueble, consulte directamente con su mueblería.

Donatilar için doğrudan servisimiz

Bir donatılar eksikliği bu servis kartını doğrudan aşağıda bulunan adrese doğrudan mail yazabilirsiniz. Sadece bu yolla donatılar gönderebiliriz. Mobilyanızda başka şikayetleriniz varsa lütfen doğrudan mobilya satıcınıza danışın.

nr	L[mm]	B[mm]	T[mm]	Menge	Coll
1	1954	400	16	1	2/2
2	1954	400	16	1	2/2
3	502	401	16	1	1/2
4	468	362	16	2	2/2
5	468	325	16	2	2/2
6	468	362	16	1	1/2
7	1122	77	38	1	2/2
8	419	463	16	2	1/2
9	419	410	16	2	1/2
10	328	387	4	1	2/2
11	1963	478	3	1	2/2

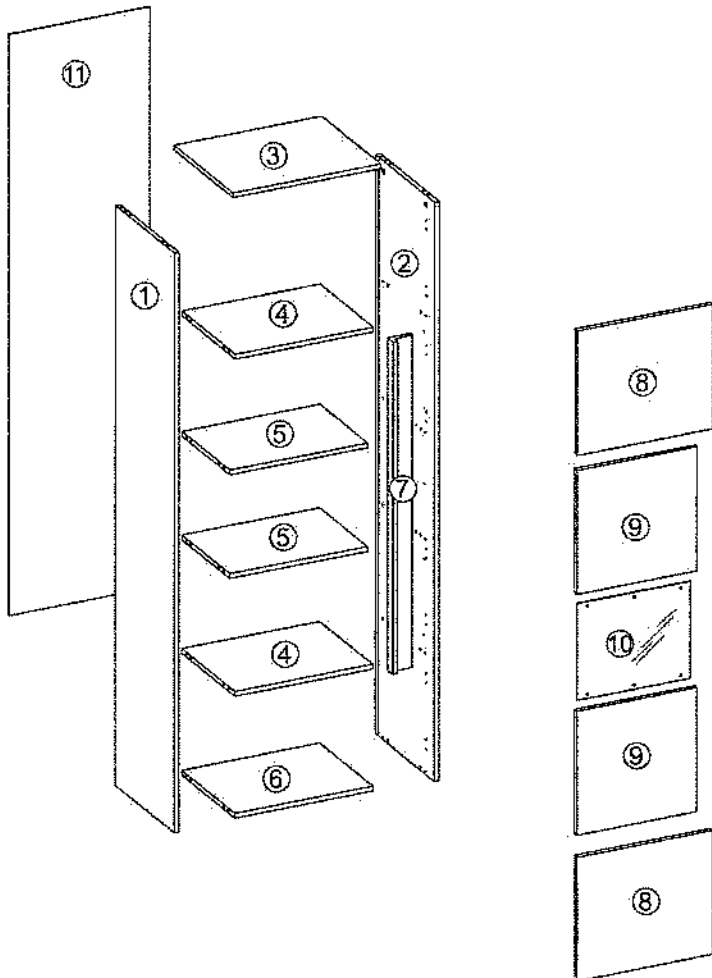

D
GB
CZ
F
I
BG
NL
PL
HR
HU
SK
SLO
RO
RUS
S
ES
TR

Modell: CITY / GIRON 33

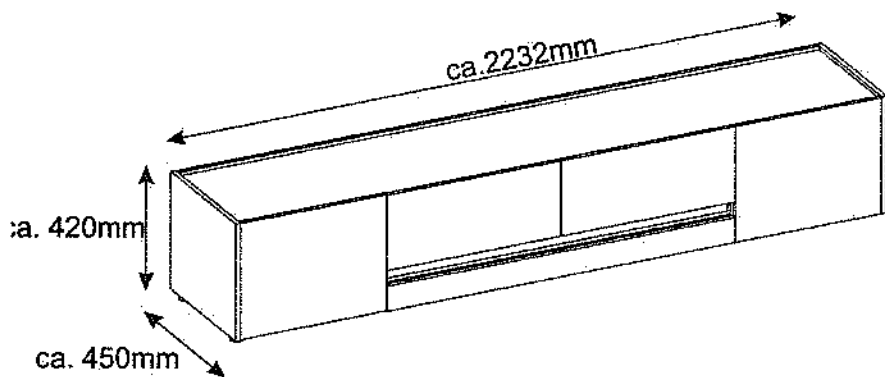

- Ⓛ Montageanleitung
- Ⓝ Handleiding voor de montage
- Ⓜ Montaj talimatı
- Ⓧ Notice de montage
- Ⓢ Montážní návod
- Ⓟ Szerelési útmutató
- Ⓠ Assembly Instructions
- Ⓡ Instrukcja montażu
- Ⓡ Инструкция по монтажу
- Ⓡ Istruzioni di montaggio
- Ⓡ Návod na montáž
- Ⓡ Instrucțiuni de montaj
- Ⓡ Instrucciones de montaje
- Ⓡ Montaj Talimatı

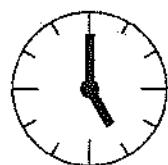
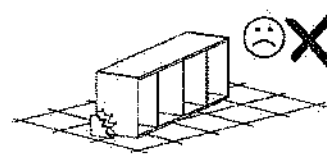
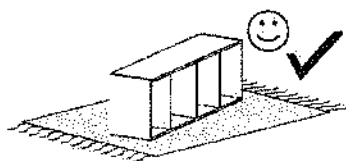
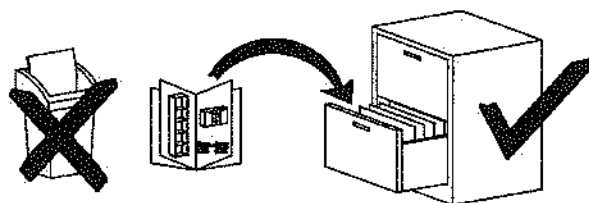
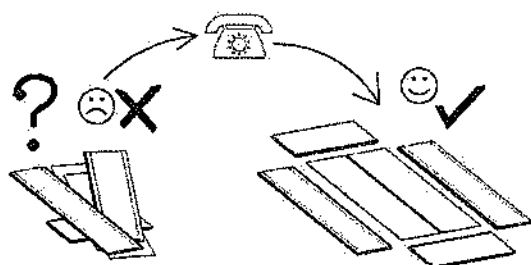
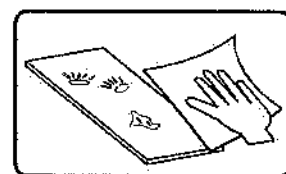
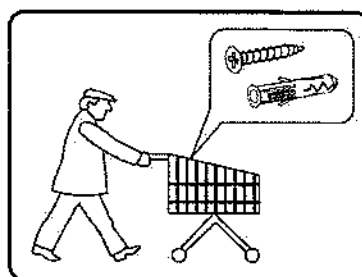
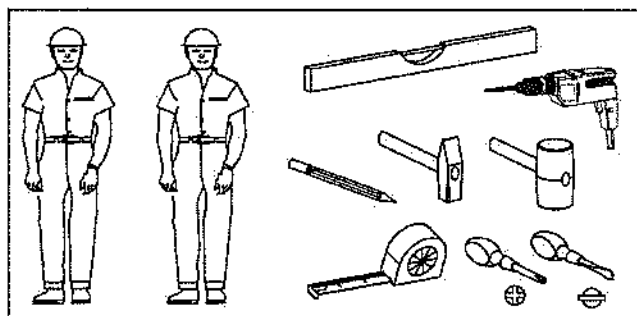

2,5h

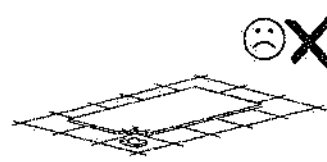
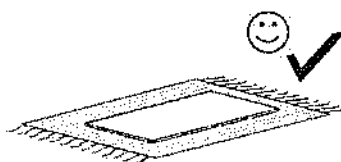

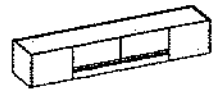





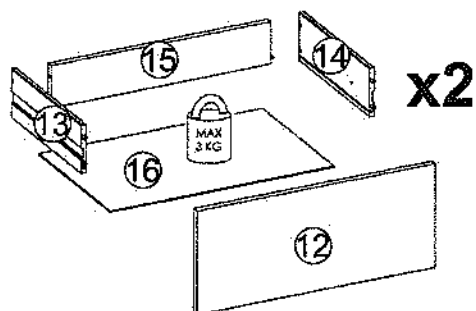
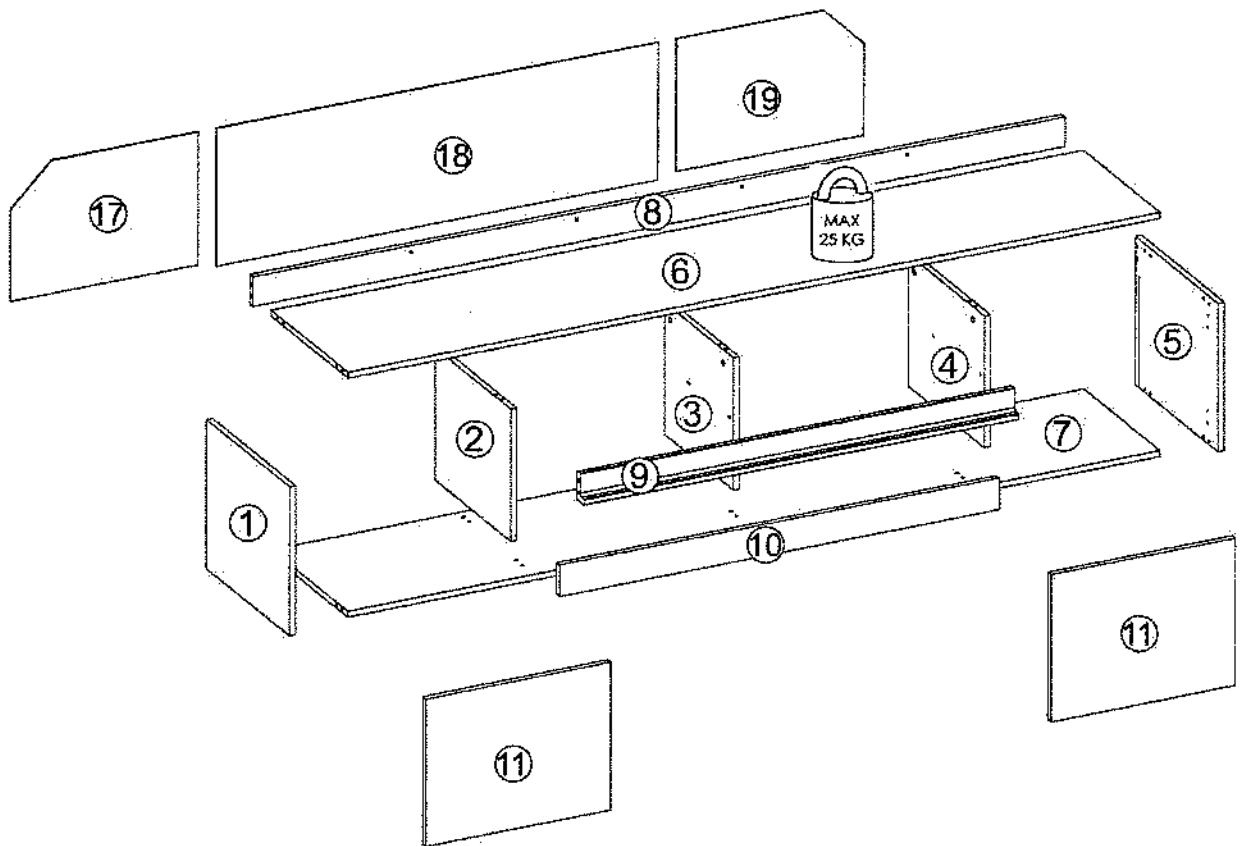

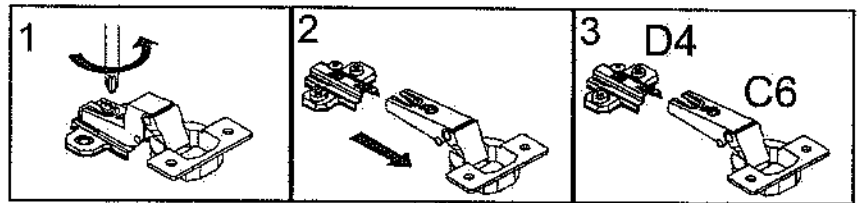
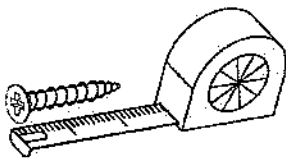
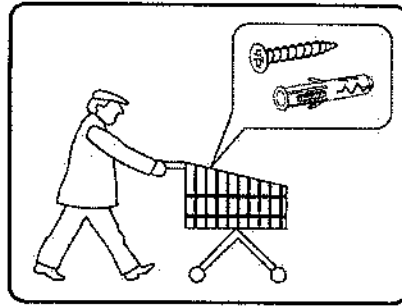





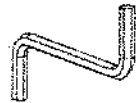





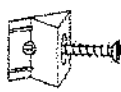
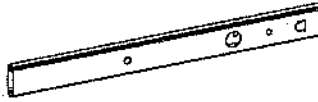

nr	L[mm]	B[mm]	T[mm]	Menge	Coll
1	400	450	16	1	1/2
2	355	411	16	1	1/2
3	355	373	16	1	1/2
4	355	411	16	1	1/2
5	400	450	16	1	1/2
6	2200	416	16	1	2/2
7	2200	412	16	1	2/2
8	2200	80	16	1	2/2
9	1178	77	38	1	2/2
10	1192	85	16	1	2/2
11	397	500	16	2	1/2

nr	L[mm]	B[mm]	T[mm]	Menge	Coll
12	595	258	16	2	1/2
13	350	120	12	2	1/2
14	350	120	12	2	1/2
15	548	105	12	2	1/2
16	558	358	3	2	2/2
17	371	508	3	1	2/2
18	371	1194	3	1	2/2
19	371	508	3	1	2/2



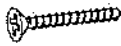

B1  $\varnothing 8 \times 35$ x26	B2  $\varnothing 6 \times 30$ x4	A1  $\varnothing 7 \times 50$ x14	W2  x1	I7  x10
K1  x16	K10  x16	D4  x4	C6  x4	G34  $3,5 \times 16$ x10
G47  $6,3 \times 13$ x8	G49  4×16 x24	F13  x4	N1  $M4 \times 9$ x4	I1  x4
H5  x4	W1  x1	M11  x2	G50  3×20 x36	
P10  x7	G36  4×30 x7	Z6  x4		

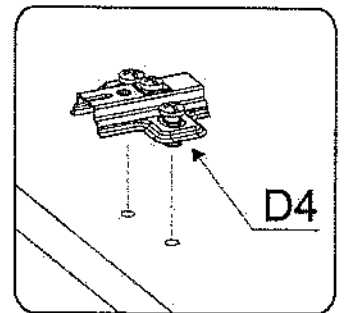
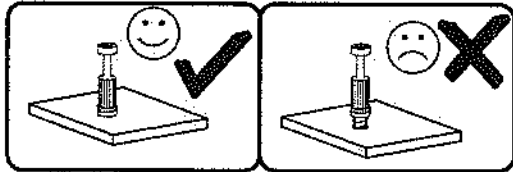
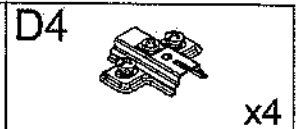
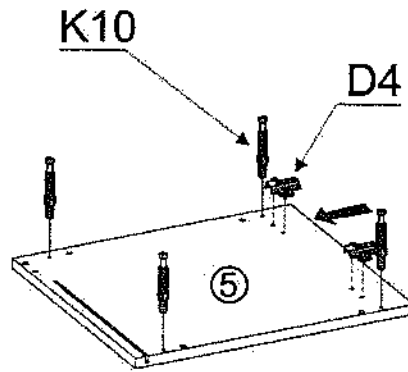
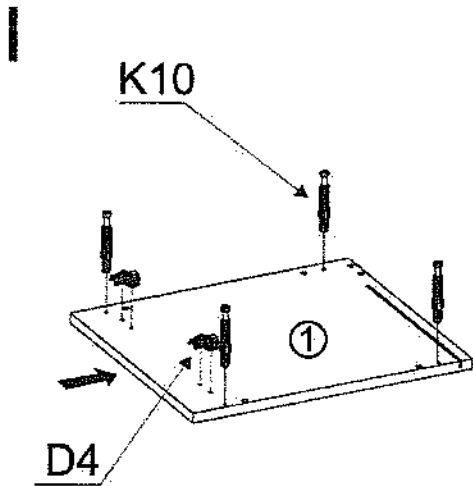

II

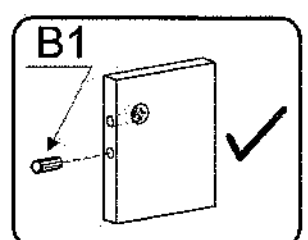
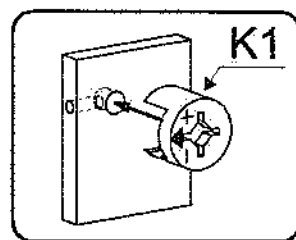
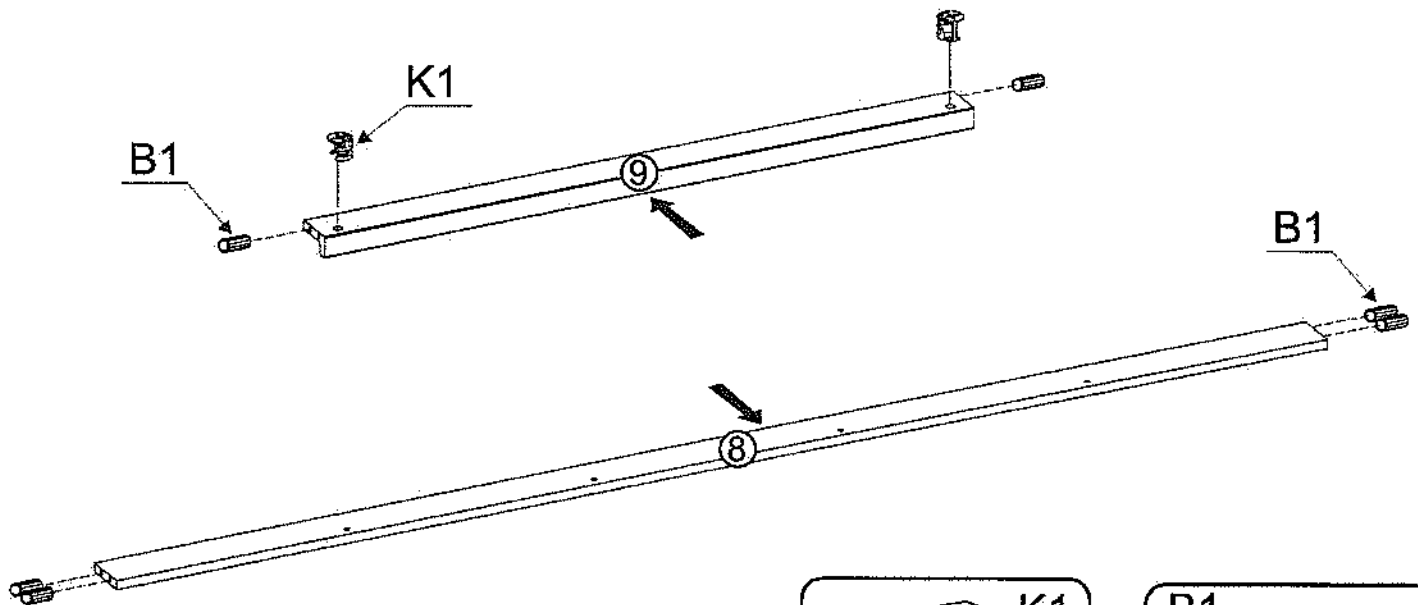
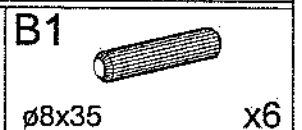

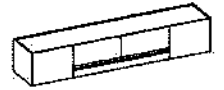

III

H5

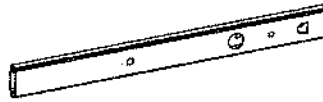

x2

K1



x8

K10



x8

G47



6,3x13

x4

B1



ø8x35

x12

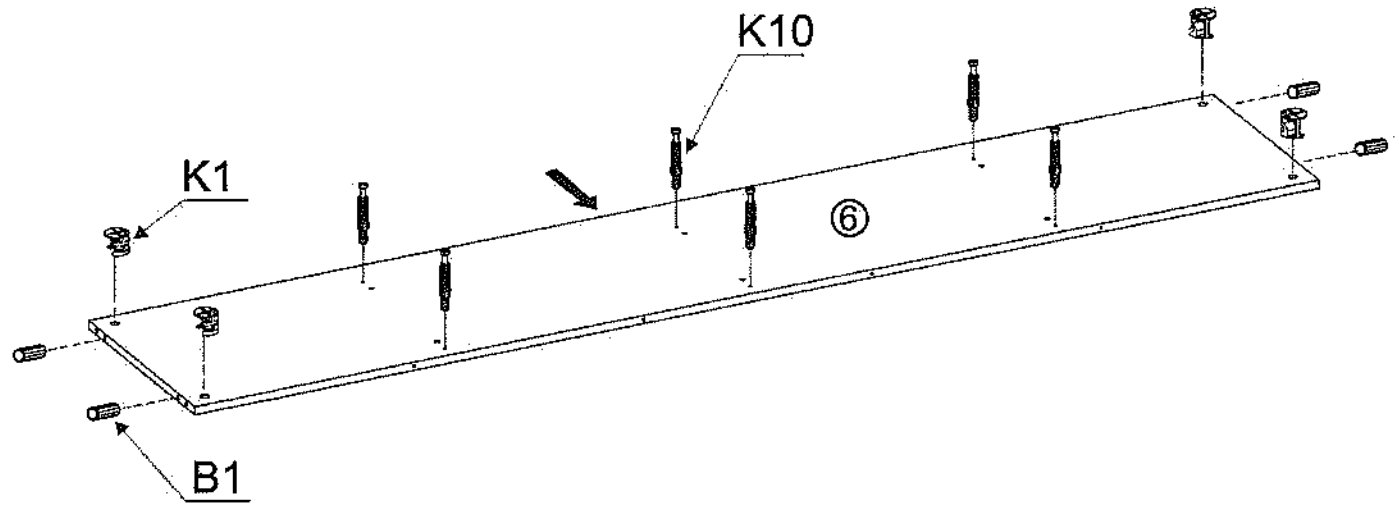
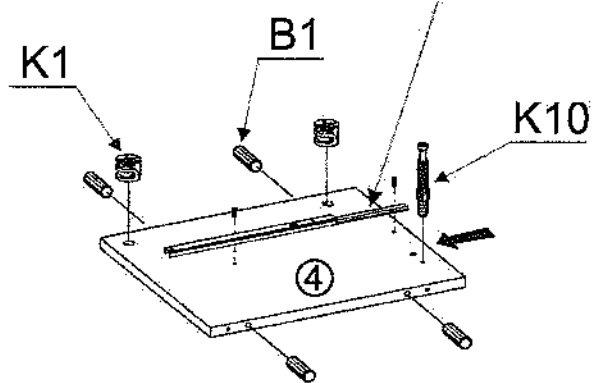
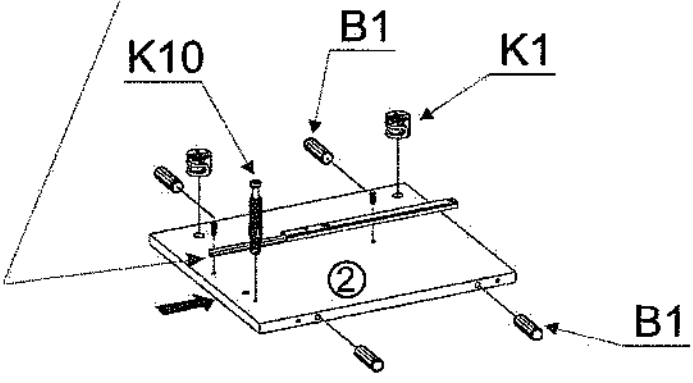
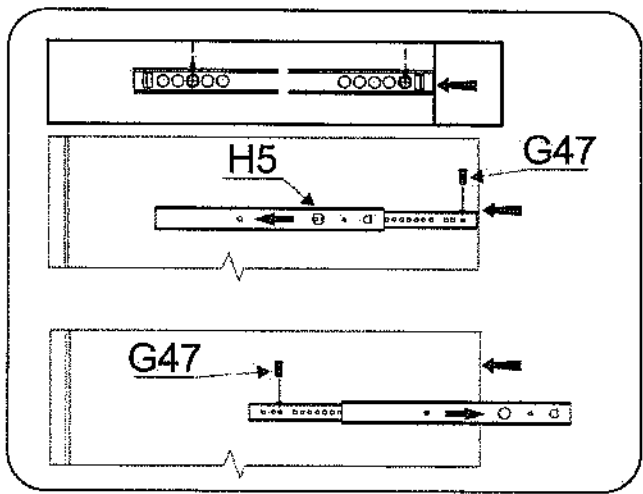
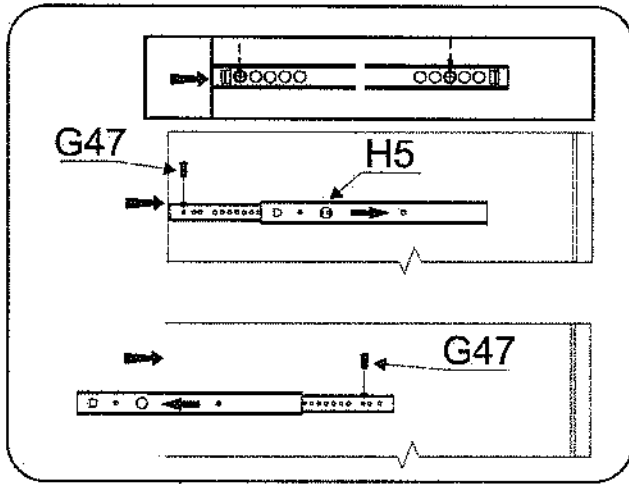



IV

H5

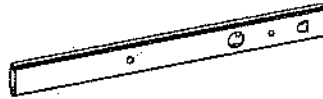

K1



x2

x2

G47



6,3x13

x4

B1



ø8x35

x4

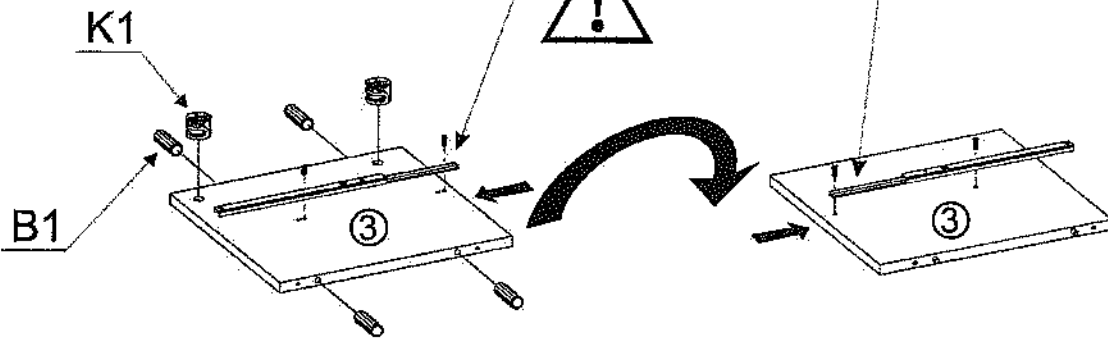
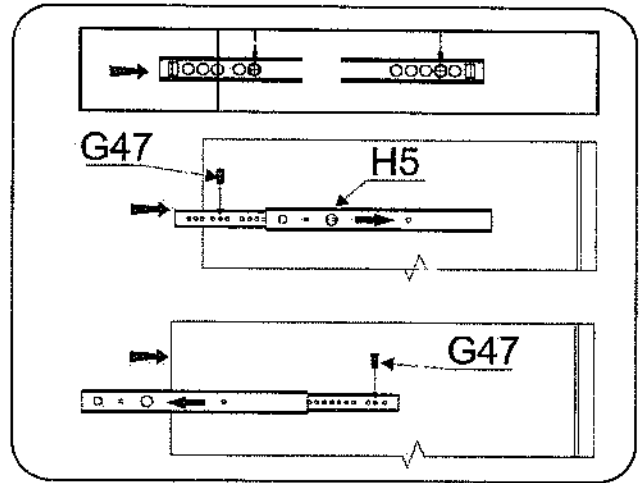
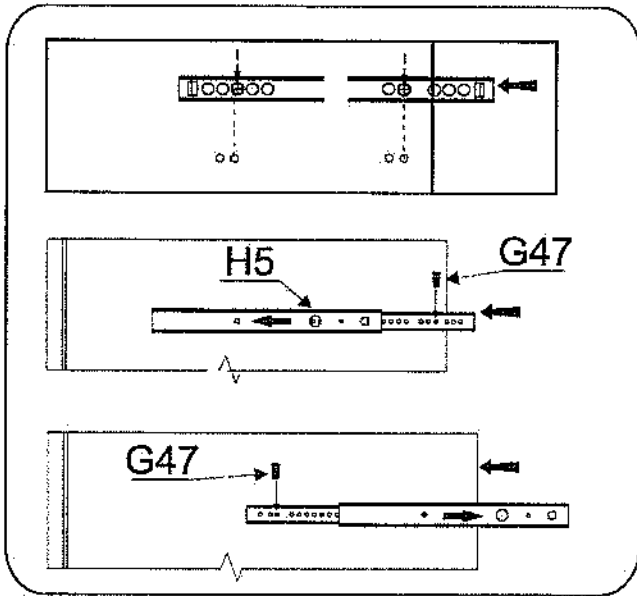



V

B1 ø8x35 x4	K1 x4	F13 x4	G49 4x16 x4
-------------------	----------	-----------	-------------------

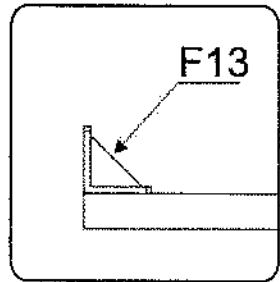
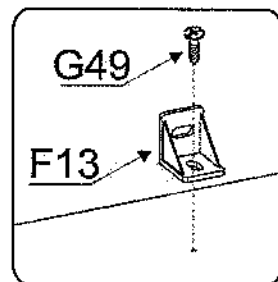
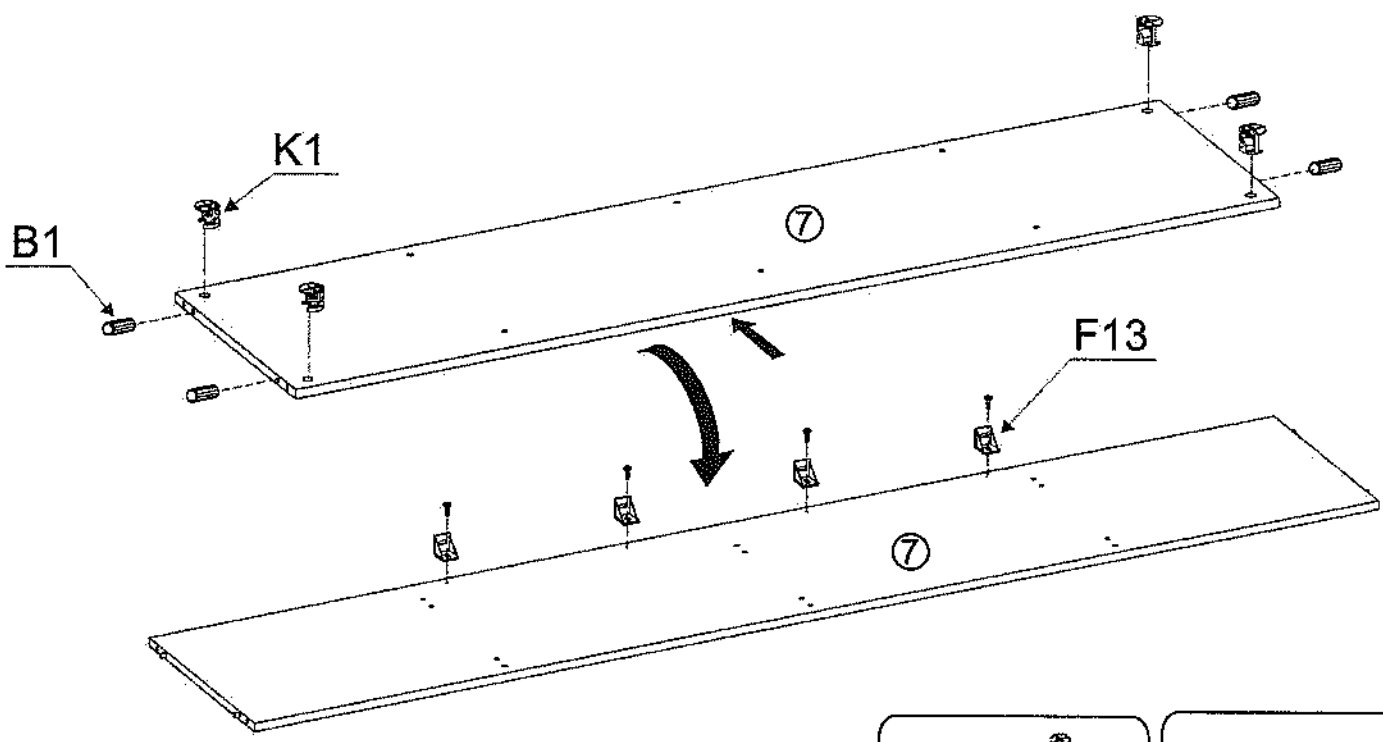

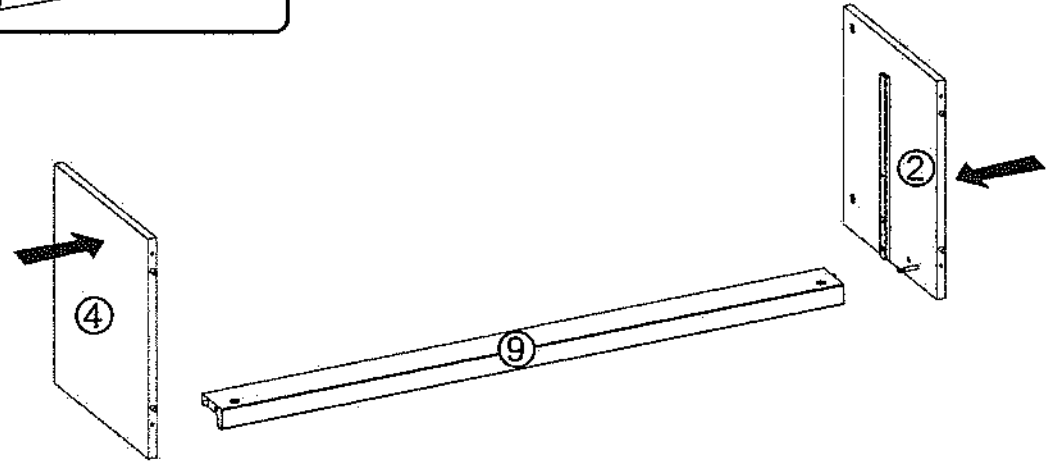
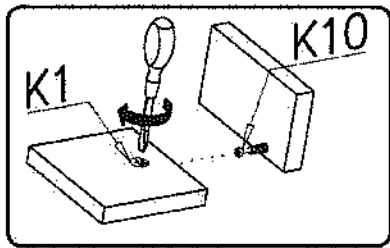

VI



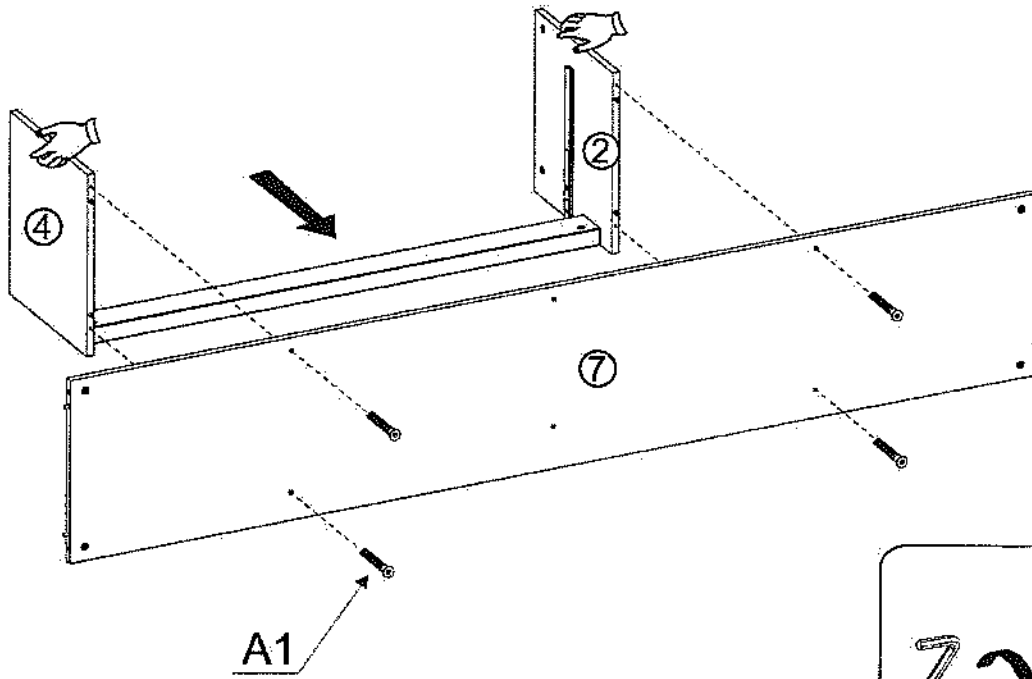

VII

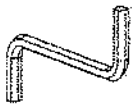

- A1  x4
- ø7x50
- W2  x1

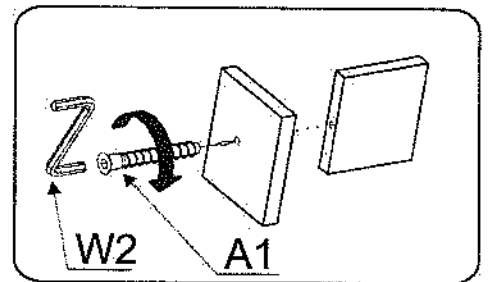

VIII

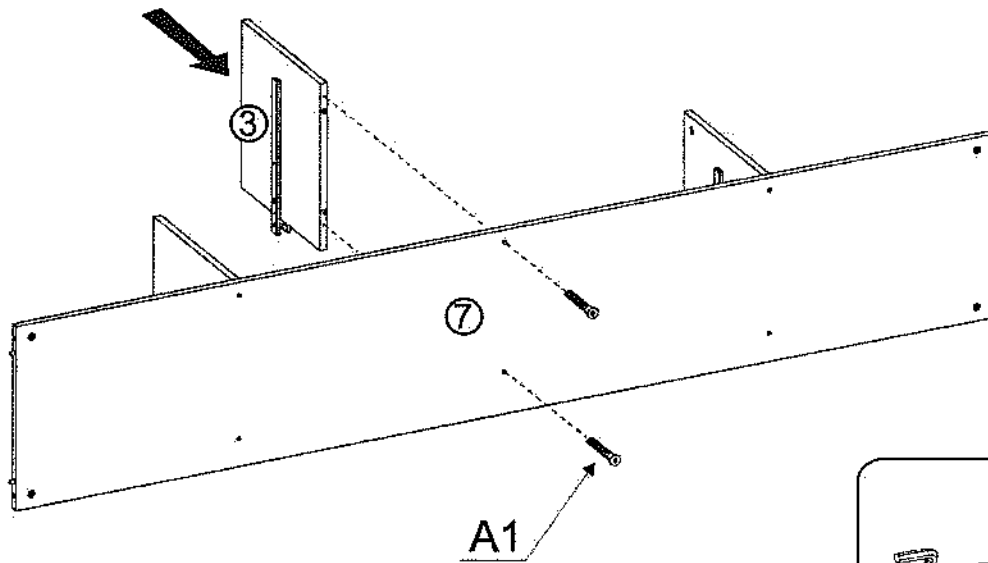

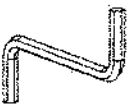
- A1  x2
- ø7x50
- W2  x1

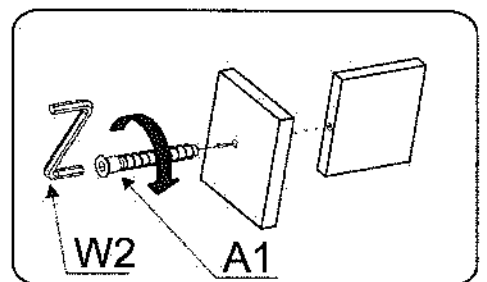



IX

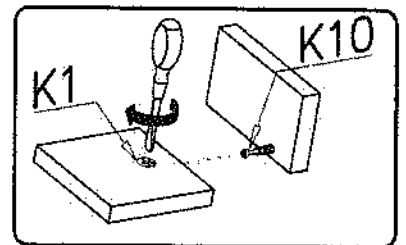
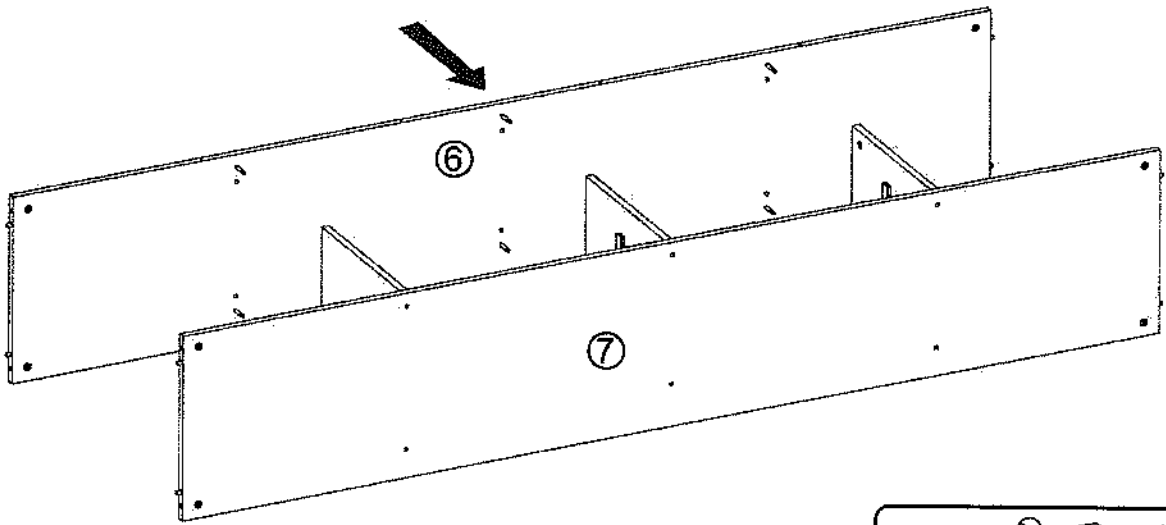

X

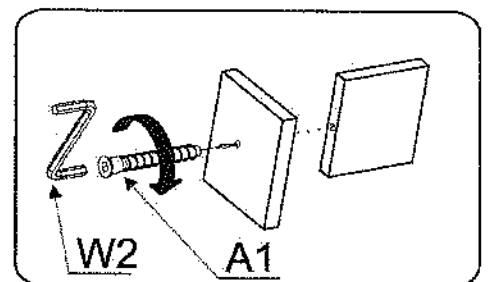
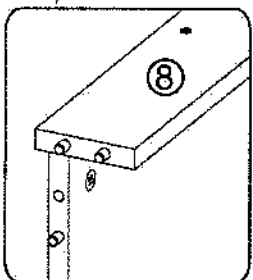
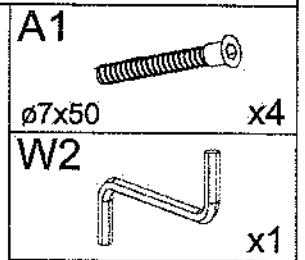
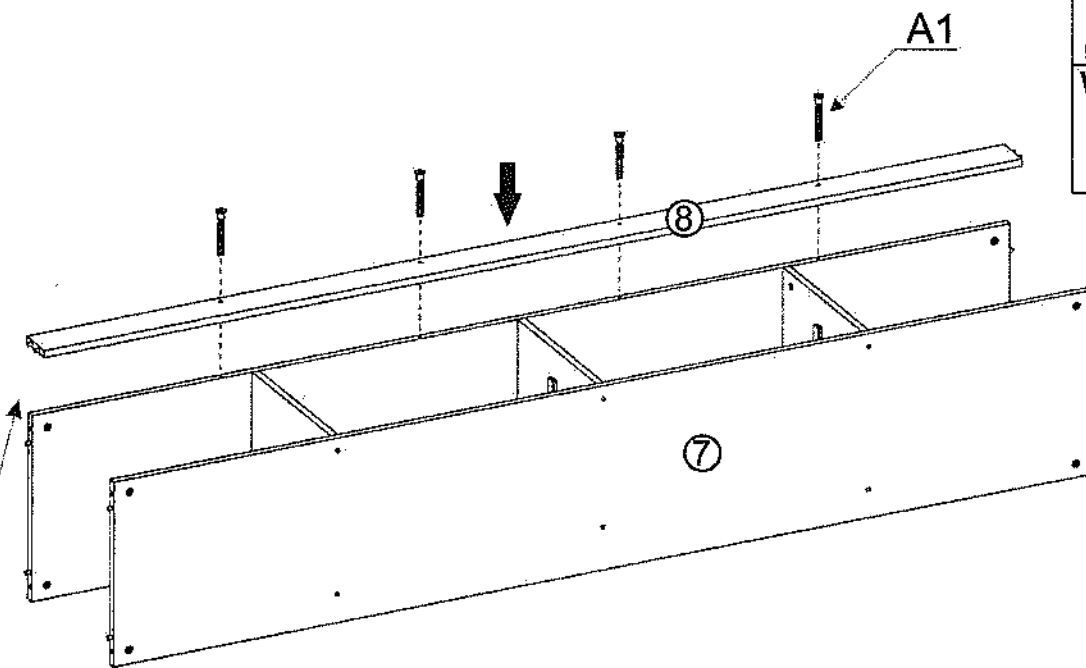



XI

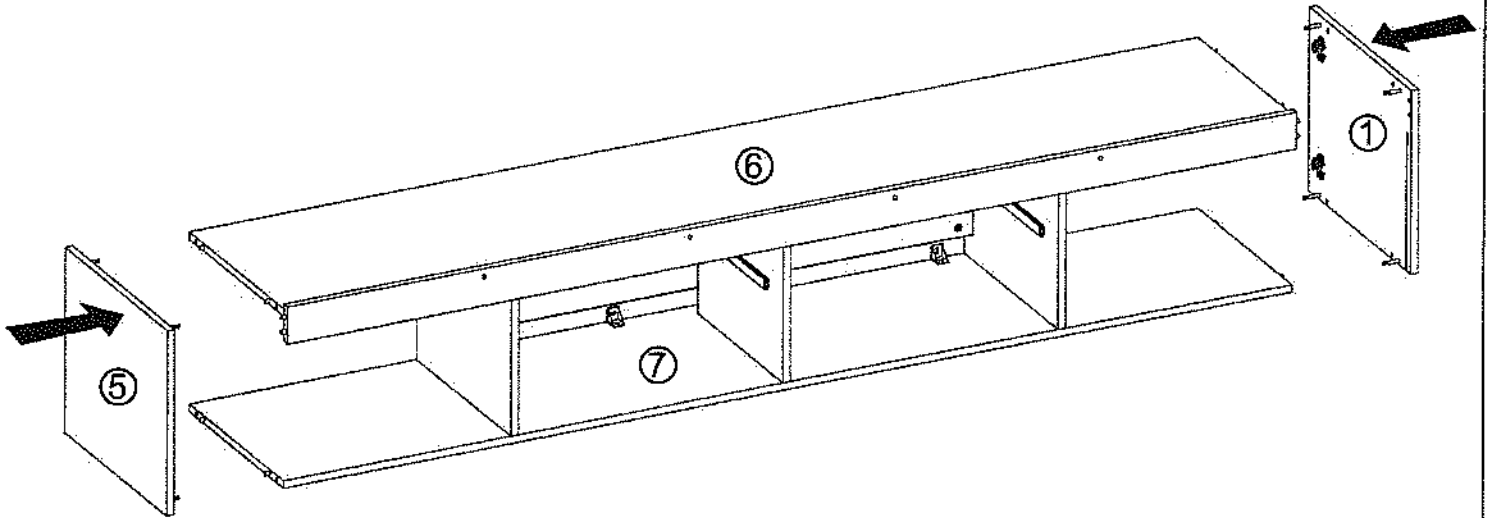
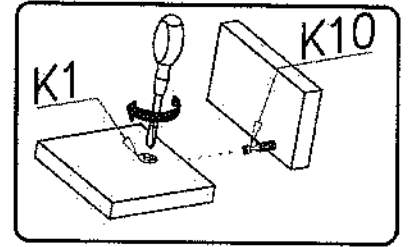
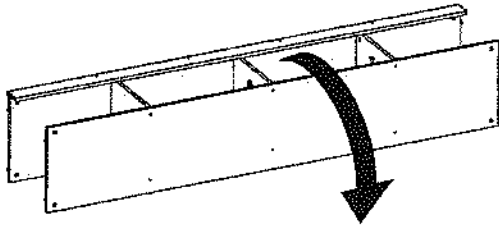

XII

G49

4x16



x4

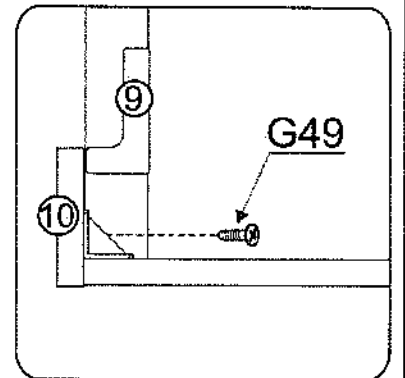
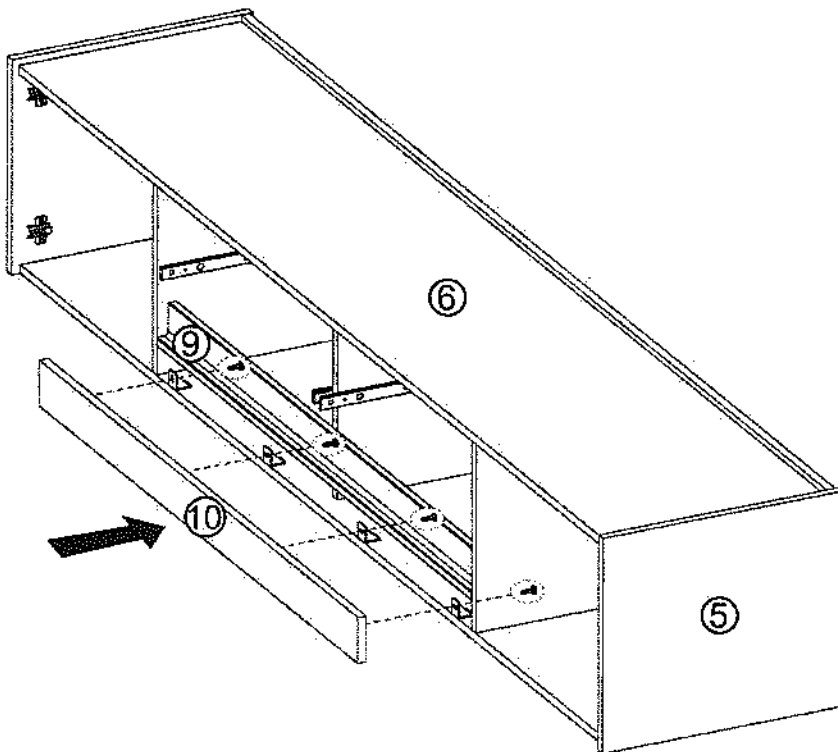

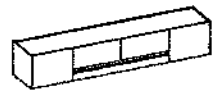



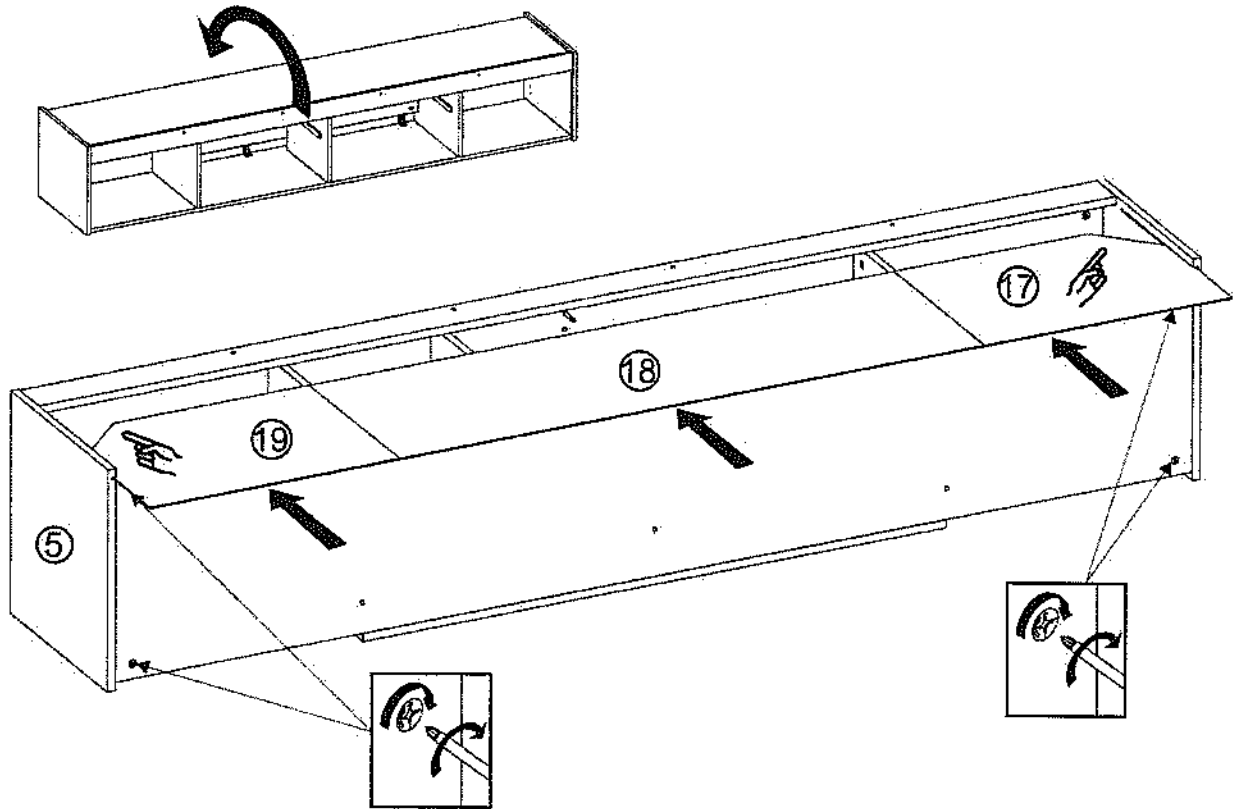

XIII

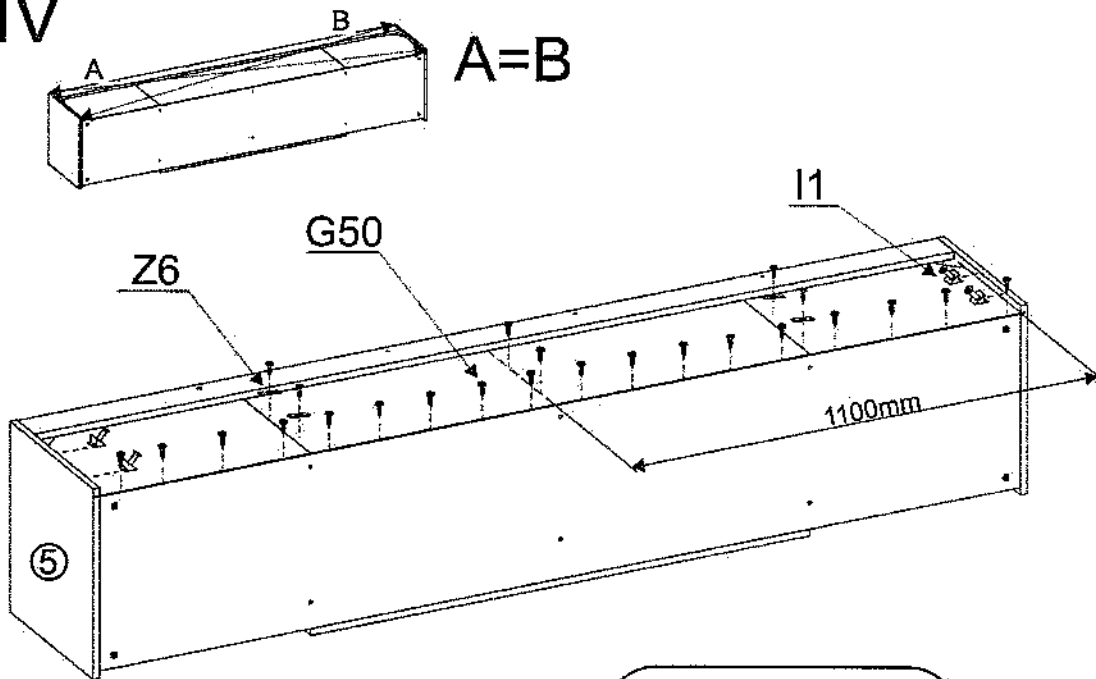

XIV

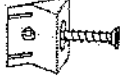

- G50  x24
- 3x20  x4
- I1  x4
- Z6  x4

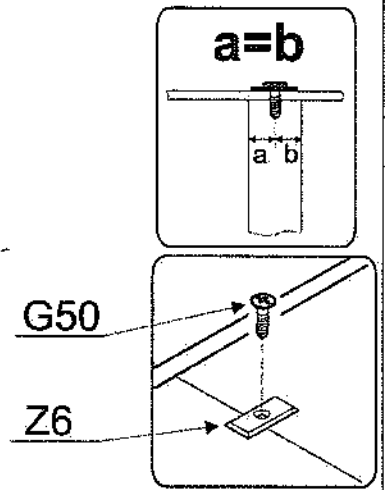
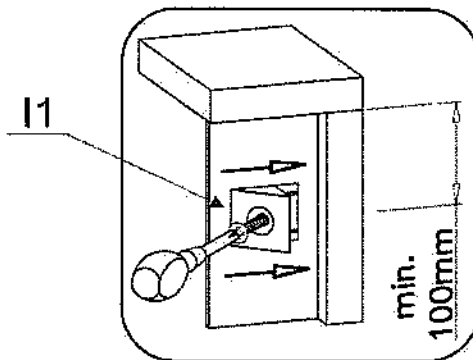
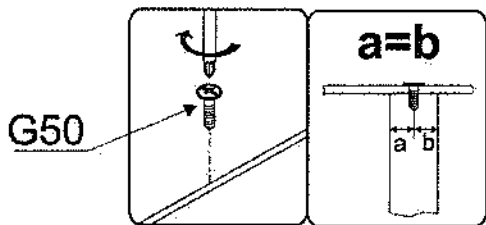



XV

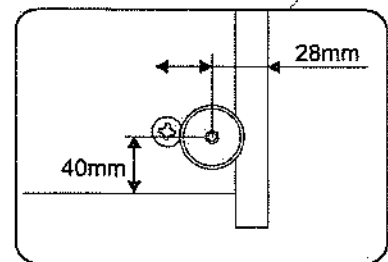
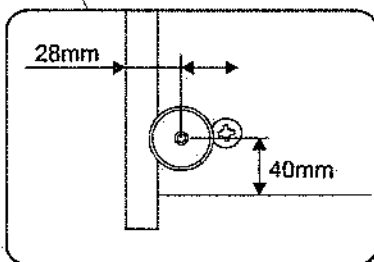
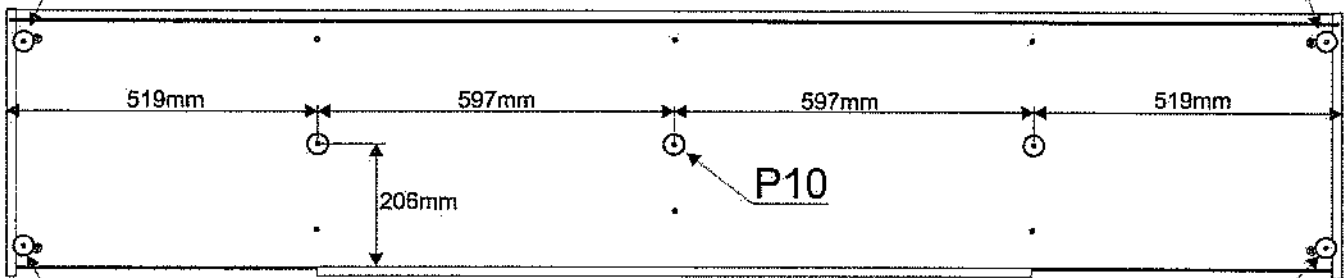
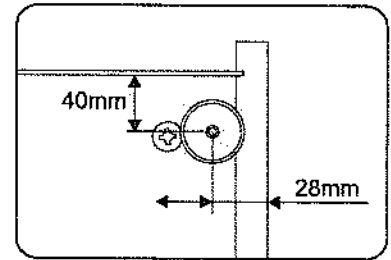
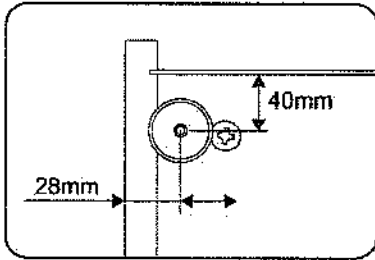
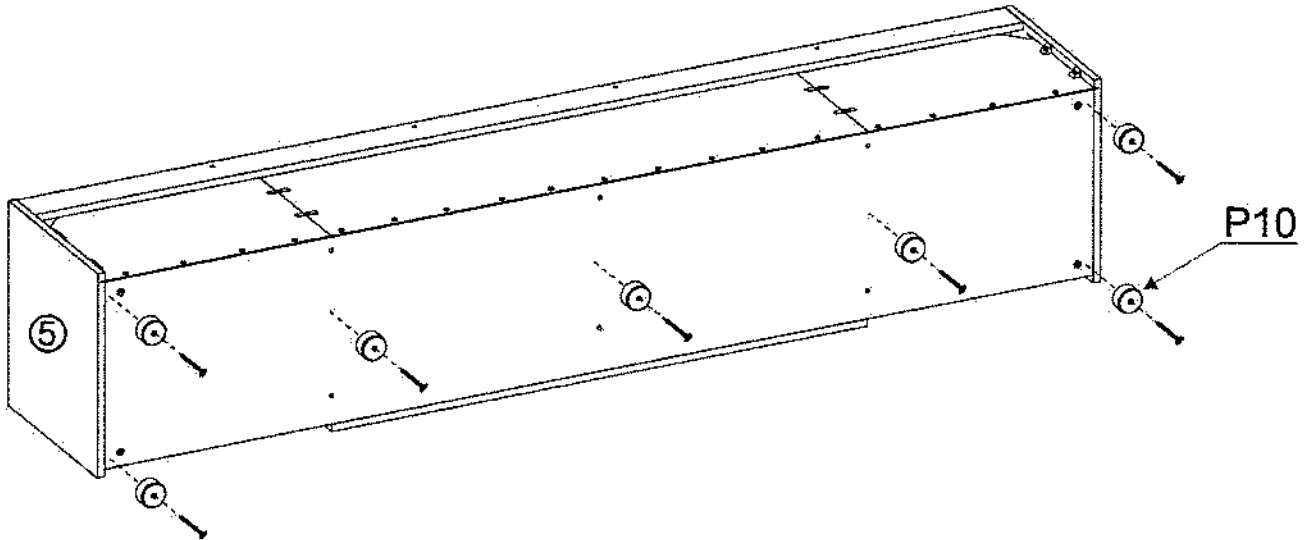
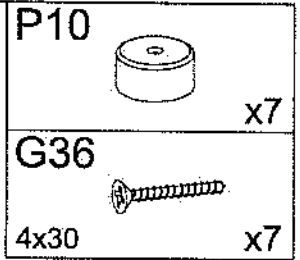
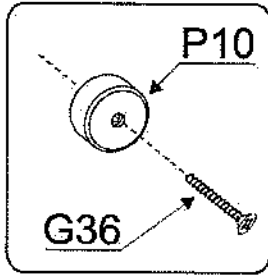

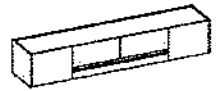

XVI

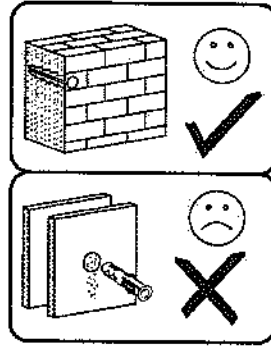
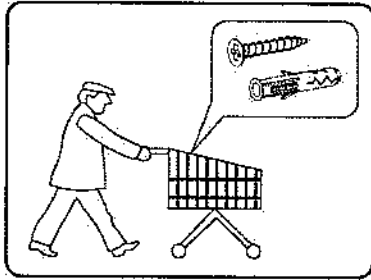

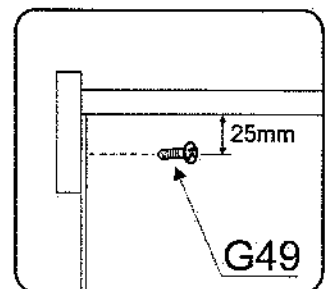
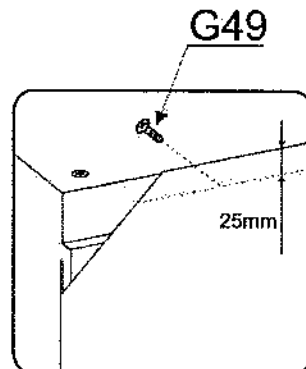
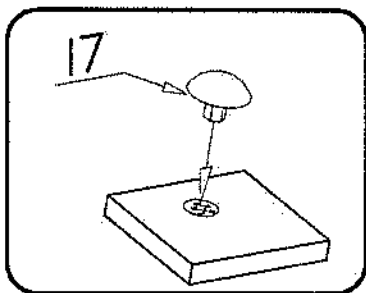
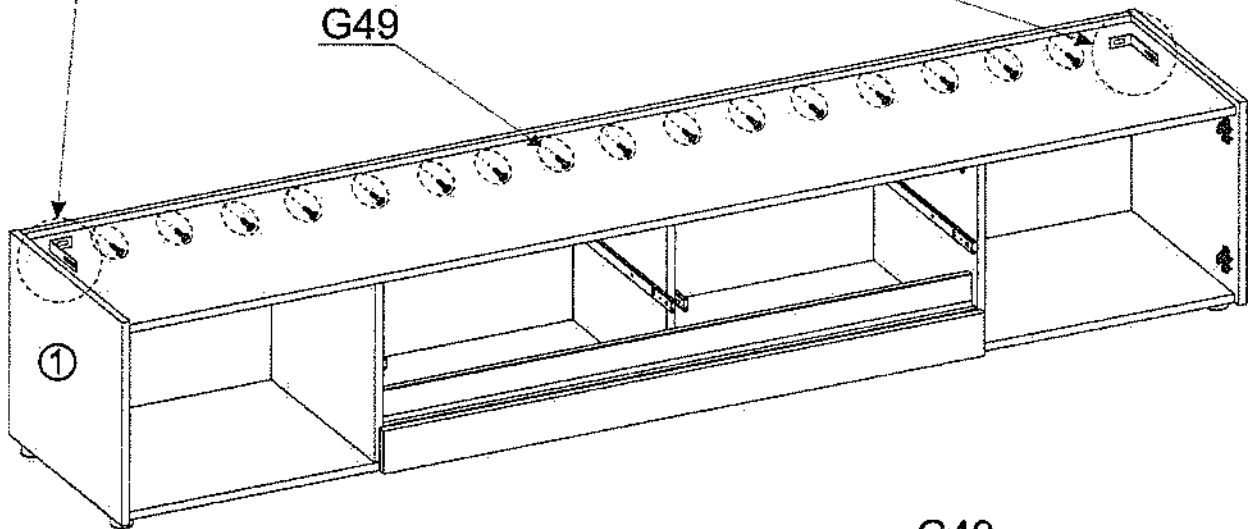
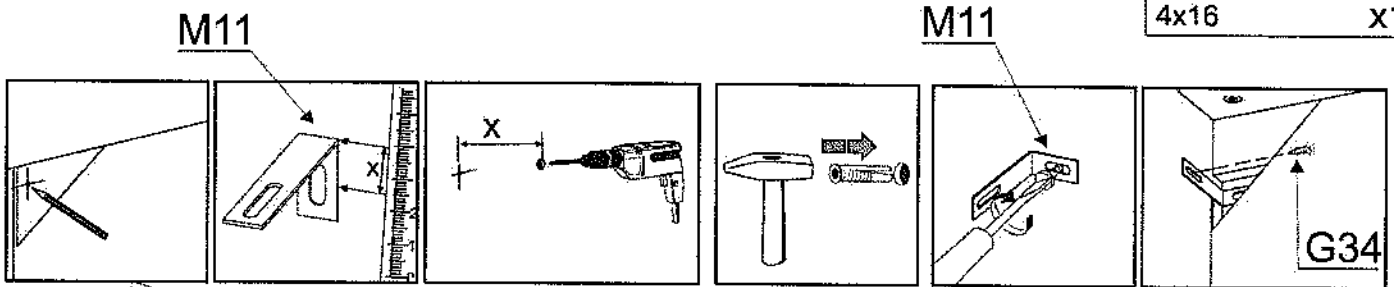

G34		
3,5x16		x2
M11		x2
I7		x10
G49		x16
4x16		

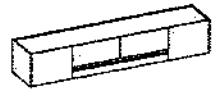



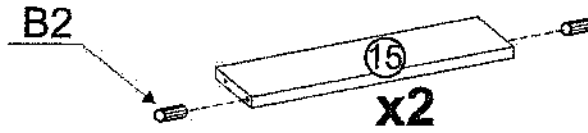

XVII

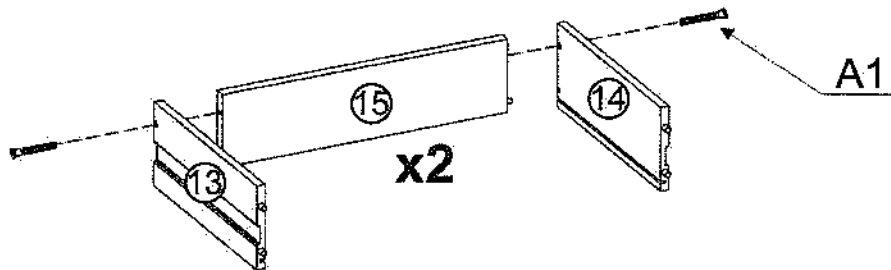

B2  x4
 ø6x30

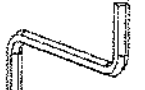

A1  x4
 ø7x50

W2  x1

W1  x1

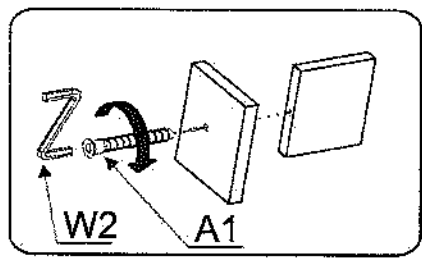
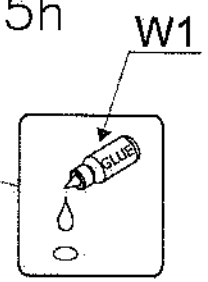
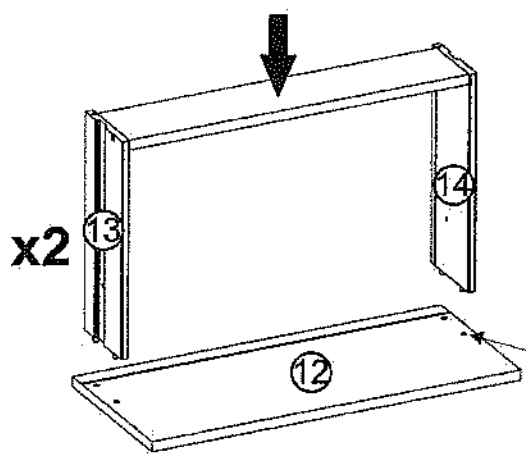

XVIII

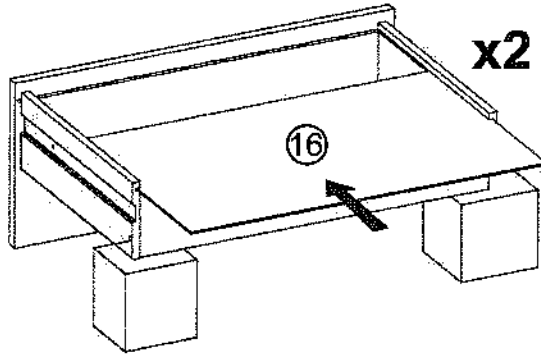

G50  x12
 3x20

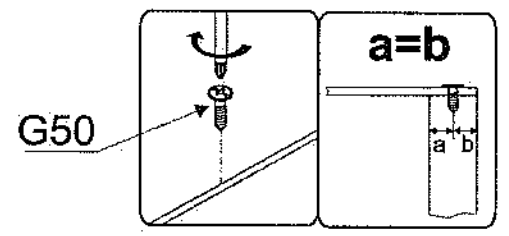
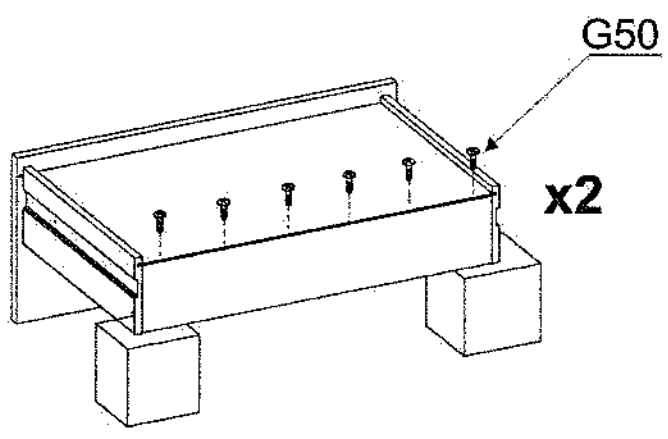



XIX

N1

M4X9



x4

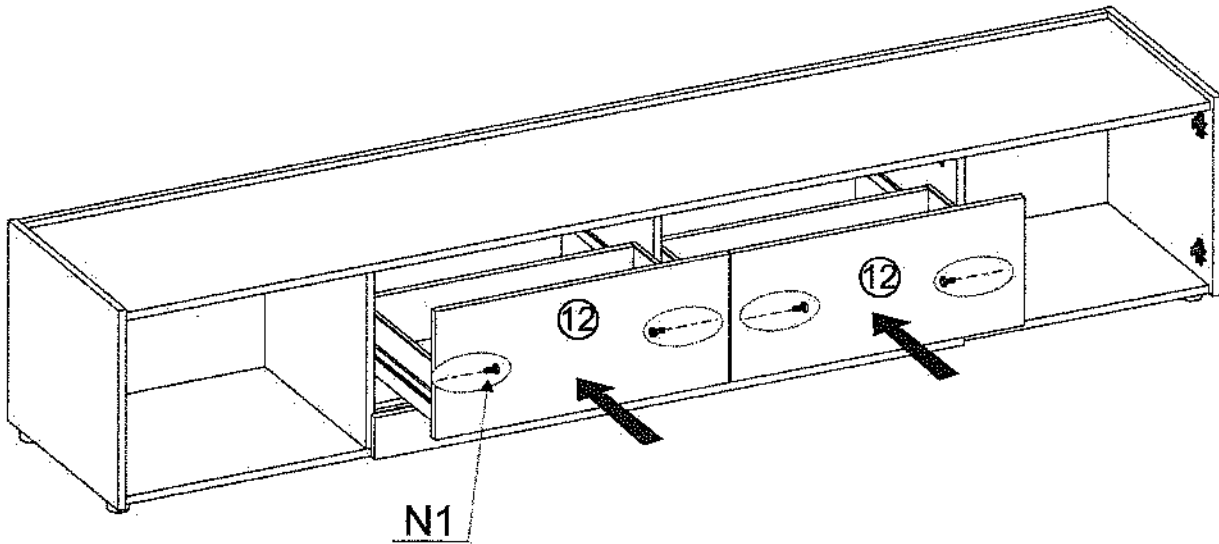
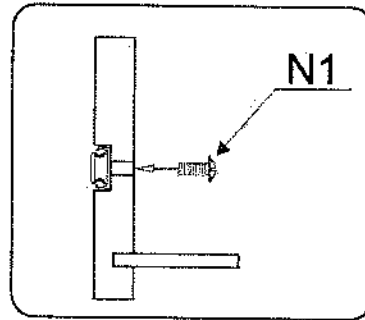
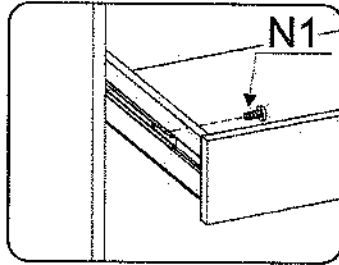
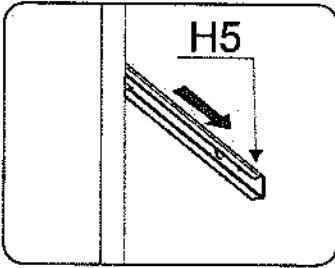

XX

C6

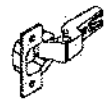

x4

G34



3,5x16

x8

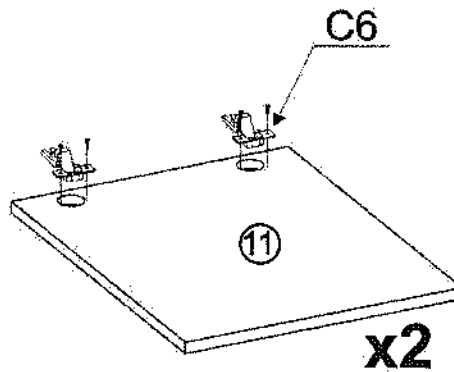

x2

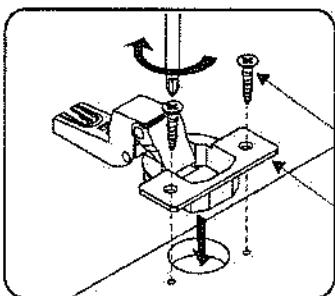

G34

C6



XXI

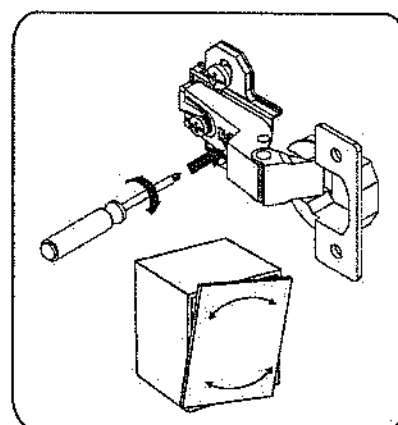
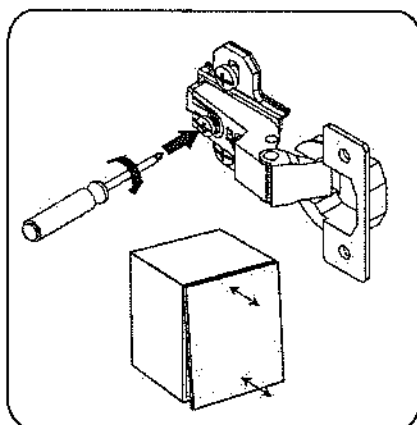
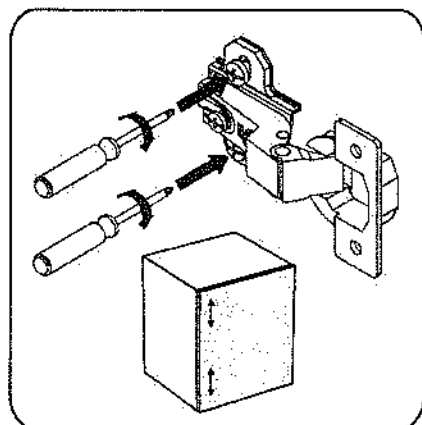
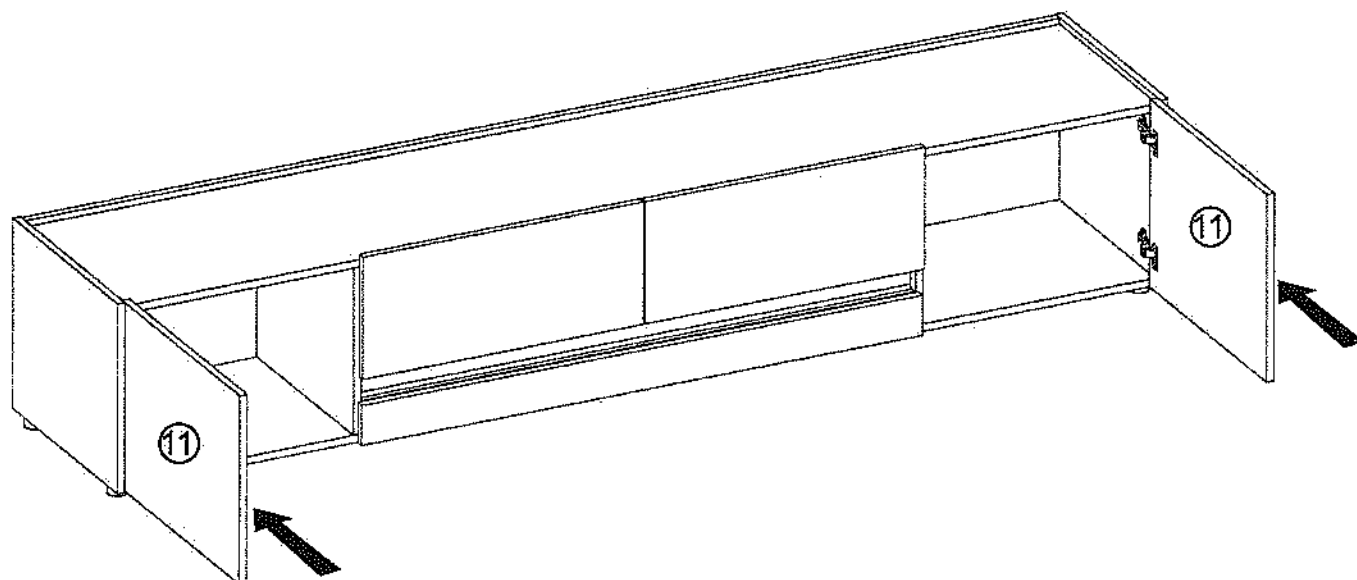
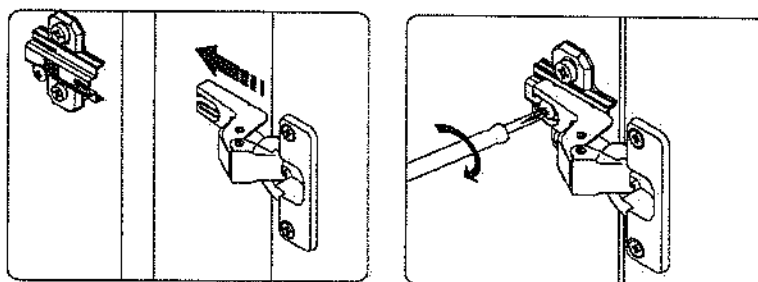

Name • Nom • Nome • Naam • Nazwa • Jméno
• Νόμος • Név • Denumire • Isim • Название

Nr • No • N° • Номер • Č • Sz

Typ • Type • Tip • Típus • Tipo • Tun

CITY / GIRON

33

D Unser Direktservice für Beschädigte
Sollte Ihnen ein Beschädigter fehlen, können Sie diese Servicekarte direkt an die untenstehende Adresse mailen. Wir können allerdings nur Beschädigte auf diesem Wege verschicken. Sollten Sie eine andere Beanstandung an Ihrem Möbelstück haben, so wenden sie sich bitte direkt an Ihr Möbelhaus.

GB Our direct order service for fittings
If a fitting part is missing, you can e-mail this service card directly to the address below. However, we can only send fitting parts in this way. If you have any other cause for complaint concerning your item of furniture, please contact your furniture store directly.

CZ Naše přímé služby pro kování
Chybí-li vám nějaký díl z kování, můžete tuto servisní kartu odeslat e-mailem přímo na níže uvedenou adresu. Touto cestou však můžeme rozeslat jen díly kování. Pokud byste reklamovali jiný díl nábytku, obraťte se přímo na svého prodejce nábytku.

F Bien servir la notice de montage
Si vous manquez une ferrure, veuillez envoyer directement la présente carte service / l'adresse e-mail indiquée ci-dessous. Cependant, ceci nous permet uniquement d'envoyer des ferrures. Pour tout autre type de réclamation concernant votre meuble, veuillez contacter directement votre magasin d'ameublement.

I Il nostro servizio diretto per l'ordine della ferramenta
Qualora Vi dovesse mancare un pezzo di fissaggio, allora Vi preghiamo di inviare questa carta di servizio immediatamente all'indirizzo sottostante. Possiamo inviare i pezzi di fissaggio solamente per mezzo di questo procedimento. Qualora dovete avere qualche altra reclamazione in merito al mobile, allora Vi preghiamo di rivolgerVi direttamente al Vostro Negozio di mobili.

BG Наши директна услуга за обков
Ако липсват части от комплекта, потърпете настоящата сервисна карта и ни я изпратете на e-mail адреса, посочен по-долу. По този начин можем да доставяме само липсващи елементи от обкова. Ако установите други дефекти по мебелите, Ви съветваме да се обвържете към мебелната къща/магазин, от който сте закупили стоката.

NL Onze directservice voor losse onderdelen
Wanneer er een onderdeel ontbreekt, kunt u deze servicekaart direct aan onderstaand e-mailadres sturen. Wij kunnen langs deze weg echter alleen beslagdelen versturen. Mocht u een ander probleem aan uw meubel hebben, verzoeken wij u contact op te nemen met uw meubeldealer.

PL Nasz bezpośredni serwis części montażowych
Jeżeli brakuje części koniecznych do montażu, prosimy o przesłanie nam niniejszej karty serwisowej na niżej podany adres e-mailowy. W ten sposób możemy przesłać Państwu tylko brakujące części. W przypadku innych reklamacji dotyczących mebla, prosimy zgłosić się do salonu meblowego, w którym został dokonany zakup.

HR Servis za obkove
U slučaju da nedostaje neki od dijelova molimo vas da na dole navedenu mail adresu pošaljete ovaj servisni obrazac. Na ovaj način mogu se dostaviti samo okovi. U slučaju da imate dodatne prigovora vezane uz komad namještaja molimo vas da se obratite izravno trgovini namještaja gdje je isti kupljen.

HU Direktszolgálatunk vasalókat esetén
Ha hiányzik egy vasalat, azt a kártyát közvetlenül elküldhetik az alább található címre. Azonban csakis vasalókat tudunk így küldeni. Amennyiben másfajta reklamáció áll fenn bútordarabját illetően, forduljon közvetlenül a bútortárházhoz.

SK Naša priama servisná časť kovaní
Ak by Vám chýbala niekako časť kovaní, môžete poslať túto servisnú kartu priamo e-mailom na nižšie uvedenú adresu. Diely kovaní vieme poslať iba týmto spôsobom. Ak by ste mali inú reklamáciu ohľadom Vášho nábytku, obraťte sa priamo na Vašu predajňu nábytku.

SLO Naše direktna uslužbna storitev za okovje
Če vam manjka kakšno okovje, lahko to servisno kartico pošljete po e-pošti direktno na spodnji naslov. Po tej poti vam lahko pošljemo samo okovje. Če želite reklamirati kakšen drug del pohištva, se obrnite neposredno na vašo trgovino pohištva.

RO Service-ul nostru direct pentru feronerie
În cazul în care vă lipsește o piesă de feronerie puteți să trimiteți direct acest card de service prin e-mail la adresa de mai jos. Noi nu putem expedia piese de feronerie decât pe această cale. Dacă aveți o altă reclamație referitoare la piesa de mobilier, atunci vă rugăm să vă adresați direct la magazinul dvs. de mobilă.

RUS Наша прямой сервис для поставок фурнитуры
Если окажется, что Вам не хватает того или иного элемента фурнитуры, Вы можете отправить сервисную карту по факсу непосредственно на нижеприведенный адрес электронной почты. Однако, таким образом мы можем пересылать лишь фурнитуру. Если же у Вас возникнут иные претензии относительно приобретенной мебели, пожалуйста, обращайтесь непосредственно в организацию, осуществившую продажу.

S Vir direktservice för beslagdelar
Om du saknar en beslagdel kan du skicka detta servicekort direkt till e-postadressen som anges nedan. Tank på att detta är den enda möjligheten att skicka beslagdelar till dig. Om du vill reklamera ditt möbel av en annan anledning måste du kontakta ditt möbelhus direkt.

ES Nuestro servicio directo para accesorios
Si le falta algún accesorio, puede enviar esta tarjeta de servicio directamente a la siguiente dirección. No obstante, por este método solo podemos enviar accesorios. Si tiene alguna otra objeción sobre su mueble, consulte directamente con su mueblería.

TR Donatılar için doğrudan servisimiz
Bir donatınız eksikse bu servis kartını doğrudan aşağıda bulunan adrese doğrudan mail yazabilirsiniz. Sadece bu yolla donatılar gönderiliriz. Mobilyanızda başka şikayetiniz varsa lütfen doğrudan mobilya satıcınıza danışın.

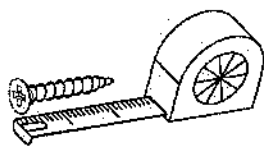

B1 ø8x35 X...	B2 ø6x30 X...	A1 ø7x50 X...
W2 X...	I7 X...	K1 X...
K10 X...	D4 X...	C6 X...
G34 3,5x16 X...	G47 6,3x13 X...	G49 4x16 X...
F13 X...	N1 M4x9 X...	I1 X...
H5 X...	G50 3x20 X...	Z6 X...
P10 X...	G36 4x30 X...	M11 X...
W1 X...		

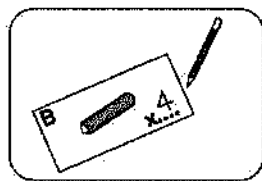

Name • Nom • Nome • Naam • Nazwa • Jméno
• Názov • Név • Denumire • Isim • Имя

Nr • No • N° • Номер • Č • Sz

Typ • Type • Tip • Түрүс • Типо • Tun

CITY / GIRON

33

Unser Direktservice für Beschädigte

Sollte Ihnen ein Beschädigtes fehlen, können Sie diese Servicekarte direkt an die untenstehende Adresse mailen. Wir können allerdings nur Beschädigte auf diesem Weg verschicken. Sollten Sie eine andere Beistandung an Ihrem Möbelstück haben, so wenden sie sich bitte direkt an Ihr Möbelhaus.

Our direct order service for fitting
If a fitting part is missing, you can e-mail this service card directly to the address below. However, we can only send fitting parts in this way. If you have any other cause for complaint concerning your item of furniture, please contact your furniture store directly.

Náša priama služba pre kování

Chybí-li vám nějaký díl z kování, můžete tuto servisní kartu odolat e-mailem přímo na níže uvedenou adresu. Touto cestou však můžeme zoslat jen díly kování. Pokud byste reklamovali jiný díl nábytku, obraťte se přímo na svého prodejce nábytku.

Bien studier la notice de montage

Si vous manqué une fermeture, veuillez envoyer directement la présente carte service à l'adresse e-mail indiquée ci-dessous. Cependant, ceci nous permet uniquement d'envoyer des fermetures. Pour tout autre type de réclamation concernant votre meuble, veuillez contacter directement votre magasin d'ameublement.

Il nostro servizio diretto per l'ordine della ferramenta

Qualora vi dovesse mancare un pezzo di fissaggio, allora vi preghiamo di inviare questa carta di servizio immediatamente all'indirizzo sottostante. Possiamo inviare i pezzi di fissaggio solamente per mezzo di questo procedimento. Qualora dovete avere qualche altra reclamazione in merito al mobile, allora vi preghiamo di rivolgerci direttamente al Vostro Negoziò di mobili.

Нашата директна услуга за обков

Ако липсва част от комплекта, потърнете настоящата сервисна карта и ни я изпратете на e-mail адреса, посочен по-долу. По този начин можем да доставяме само липсващи елементи от обкова. Ако установите други дефекти по мебелите, Ви съветваме да се обрънете към мебелната къща/магазин, от който сте закупили стоката.

Onze directservice voor losse onderdelen

Wanneer er een onderdeel ontbreekt, kunt u deze servicekaart direct aan onderstaand e-mailadres sturen. Wij kunnen langs deze weg echter alleen losse onderdelen versturen. Mocht u een ander probleem aan uw meubel hebben, verzoeken wij u contact op te nemen met uw meubeldealer.

Nasz bezpośredni serwis części montażowych

Jeżeli brakuje części koniecznych do montażu, prosimy o przesłanie nam niniejszej karty serwisowej na niżej podany adres e-mailowy. W ten sposób możemy przesyłać Państwu tylko brakujące części. W przypadku innych reklamacji dotyczących mebla, prosimy zgłosić się do salonu meblowego, w którym został dokonany zakup.

Сervis за оковје

U slučaju da nedostaje neki od dijelova molimo vas da na dole navedenu mail adresu pošaljete ovaj servisni obrazac. Na ovaj način mogu se dostaviti samo okovi. U slučaju da imate dodatne prigovore vezane uz komad namještaja molimo vas da se obratite izravno trgovini namještaja gdje je isti kupljen.

Direktzorgelstukken vastzetten

Ha hiányzik egy vasalat, ezt a kártyát közvetlenül elküldheti az alább található címre. Azonban csak vasalatokat tudunk így küldeni. Amennyiben másfélja reklamáció áll fenn bőtoráratját illetően, forduljon közvetlenül a bőtorárházhoz.

Náš priamy servis pre časti kovania

Ak by Vám chýbala nejaká časť kovania, môžete poslať túto servisnú kartu, poslať e-mailom na nižšie uvedené adresu. Diely kovania vieme poslať iba týmto spôsobom. Ak by ste mali inú reklamáciu ohľadom Vášho nábytku, obraťte sa priamo na Vašu predajňu nábytku.

Náša direktna uslužna storitva za okovje

Če vam manjka kakšno okovje, lahko to servisno kartico pošljete po e-pošti direktno na spodnji naslov. Po tej poti vam lahko pošljemo samo okovje. Če želite reklamirati kakšen drug del pohištva, se obrnite neposredno na vaše trgovino pohištva.

Service-ul nostru direct pentru feronerie

În cazul în care vă lipsește o piesă de feronerie puteți să trimiteți direct acest card de service prin e-mail la adresa de mai jos. Noi nu putem expedia piesa de feronerie decât pe această cale. Dacă aveți o altă reclamație referitoare la piesa de mobilier, atunci vă rugăm să vă adresați direct la magazinul dvs. de mobilier.

Наш прямой сервис для поставок фурнитуры

Если окажется, что Вам не хватает той или иного элемента фурнитуры, Вы можете отправить сервисную карту по факсу непосредственно на нижеприведенный адрес электронной почты. Однако, таким образом мы можем пересылать лишь фурнитуру. Если же у Вас возникнут иные претензии относительно приобретенной мебели, пожалуйста, обращайтесь непосредственно в организацию, осуществляющую продажу.

Vår direktservice för beslagsskedar

Om du saknar en beslagsskedar kan du skicka detta servicekort direkt till e-postadressen som anges nedan. Tänk på att detta är den enda möjligheten att skicka beslagsskedar till dig. Om du vill reklamera din möbel av en annan anledning måste du kontakta ditt möbelhus direkt.

Nuestro servicio directo para accesorios

Si le falta algún accesorio, puede enviar esta tarjeta de servicio directamente a la siguiente dirección. No obstante, por este método solo podemos enviar accesorios. Si tiene alguna otra objeción sobre su mueble, consulte directamente con su mueblería.

Donatılar için doğrudan servisimiz

Bir donatınız eksikse bu servis kartını doğrudan aşağıda bulunan adrese doğrudan mail yazabilirsiniz. Sadece bu yolla donatılar gönderiliriz. Mobilyanızda başka şikayetleriniz varsa lütfen doğrudan mobilya satıcınıza danışın.

nr	L[mm]	B[mm]	T[mm]	Menge	Coil
1	400	450	16	1	1/2
2	355	411	16	1	1/2
3	355	373	16	1	1/2
4	355	411	16	1	1/2
5	400	450	16	1	1/2
6	2200	416	16	1	2/2
7	2200	412	16	1	2/2
8	2200	80	16	1	2/2
9	1178	77	38	1	2/2
10	1192	85	16	1	2/2
11	397	500	16	2	1/2

nr	L[mm]	B[mm]	T[mm]	Menge	Coil
12	595	258	16	2	1/2
13	350	120	12	2	1/2
14	350	120	12	2	1/2
15	548	105	12	2	1/2
16	558	358	3	2	2/2
17	371	508	3	1	2/2
18	371	1194	3	1	2/2
19	371	508	3	1	2/2

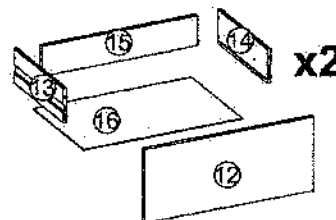
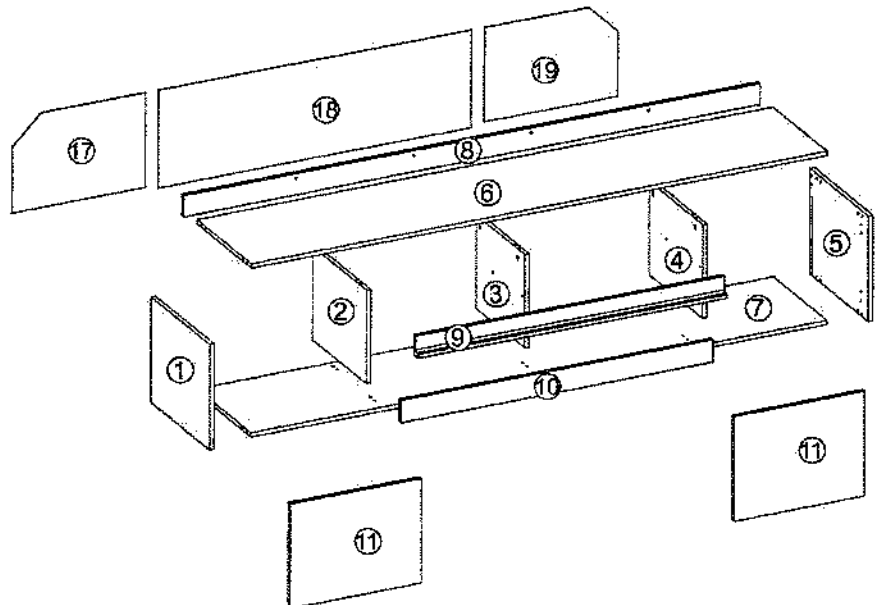

D

GB

CZ

F

I

BG

NL

PL

HR

HU

SK

SLO

RO

RUS

S

ES

TR

Modell: CITY / GIRON 72

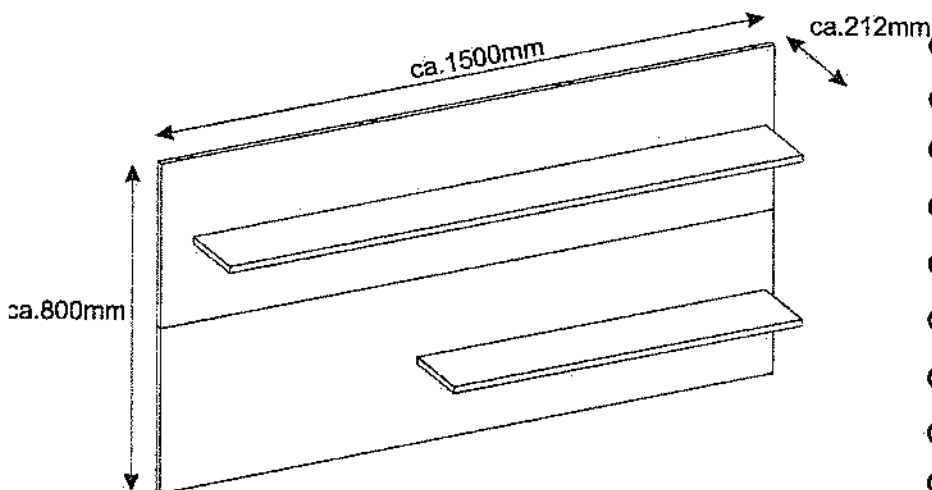

- Ⓓ Montageanleitung
- Ⓐ Handleiding voor de montage
- Ⓓ Montaj talimatı
- Ⓕ Notice de montage
- Ⓒ Montážní návod
- Ⓗ Szereelési útmutató
- Ⓒ Assembly Instructions
- Ⓐ Instrukcja montażu
- Ⓒ Инструкция по монтажу
- Ⓘ Istruzioni di montaggio
- Ⓐ Návod na montáž
- Ⓐ Instrucțiunile de montaj
- Ⓒ Instrucciones de montaje
- Ⓓ Montaj Talimatı

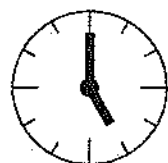
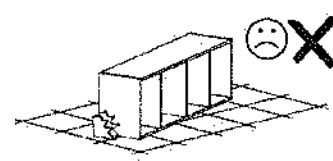
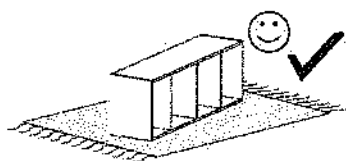
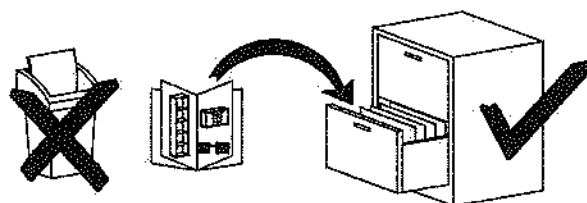
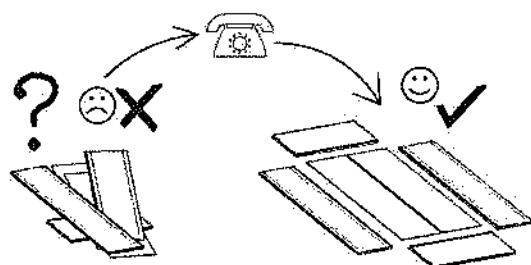
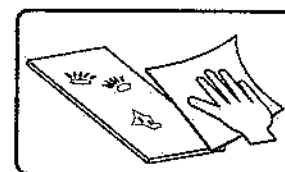
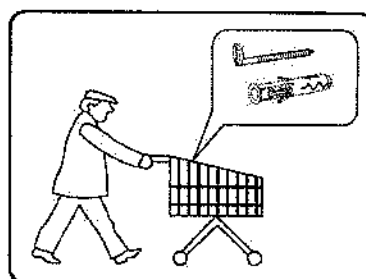
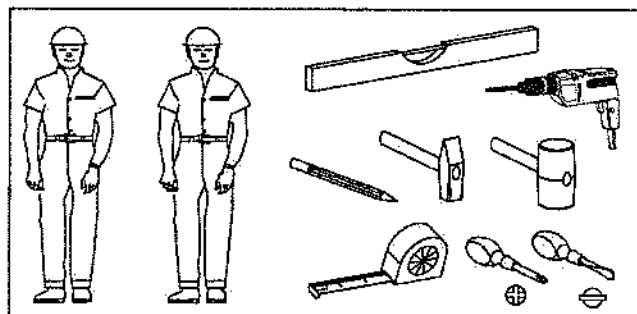

0,5h

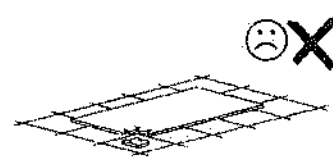
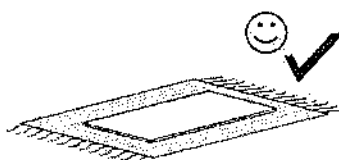





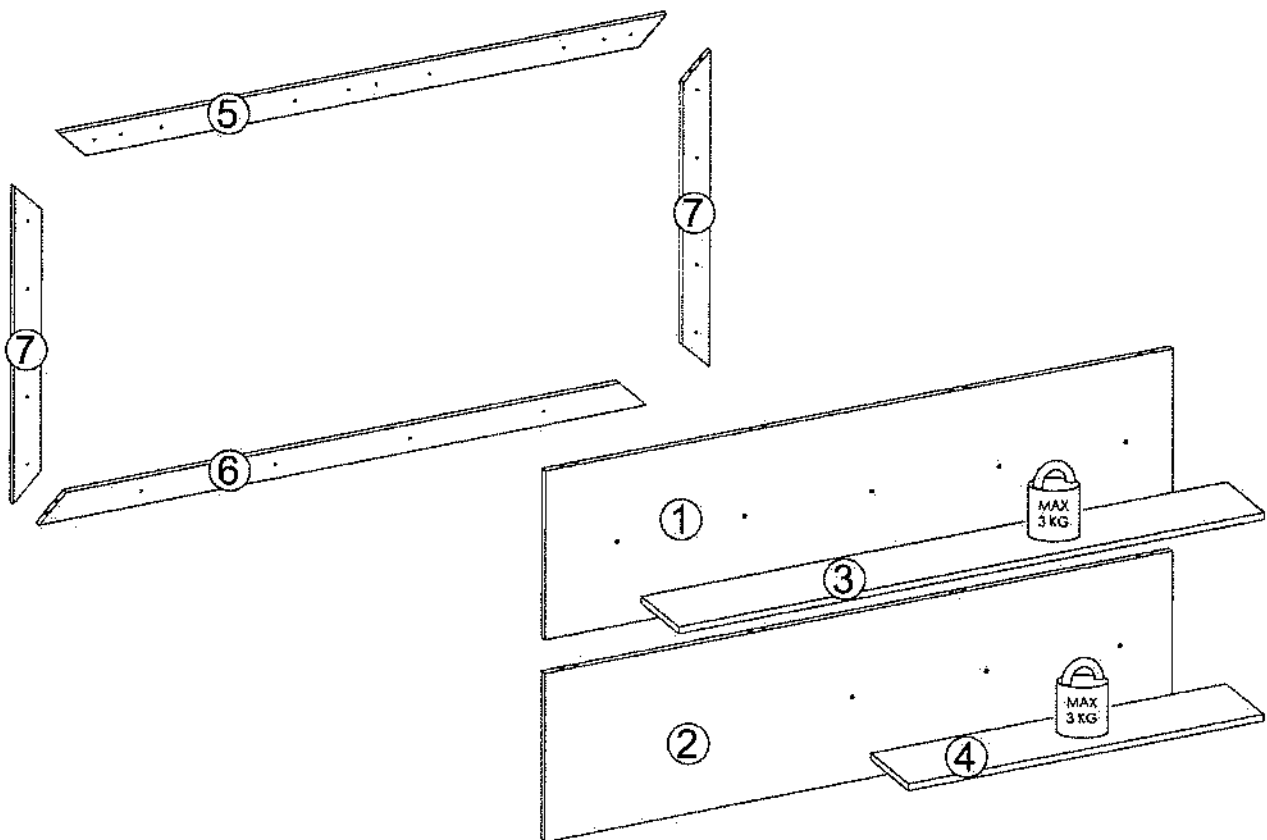

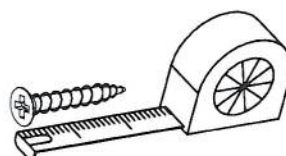
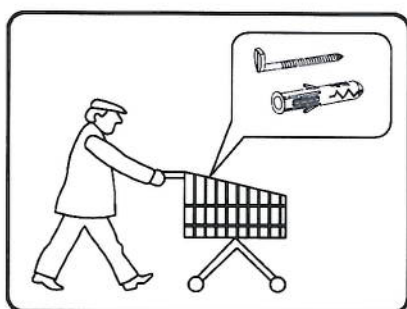
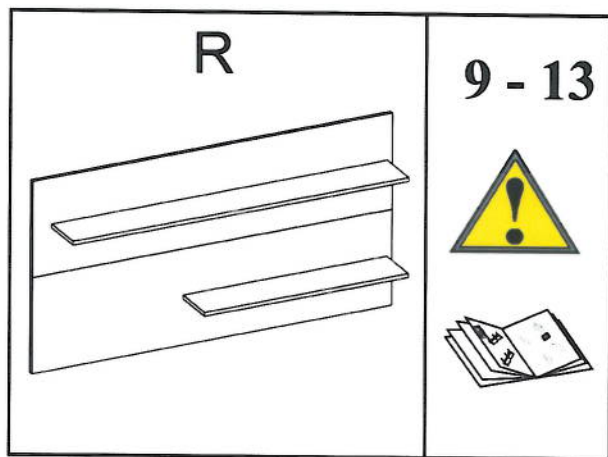
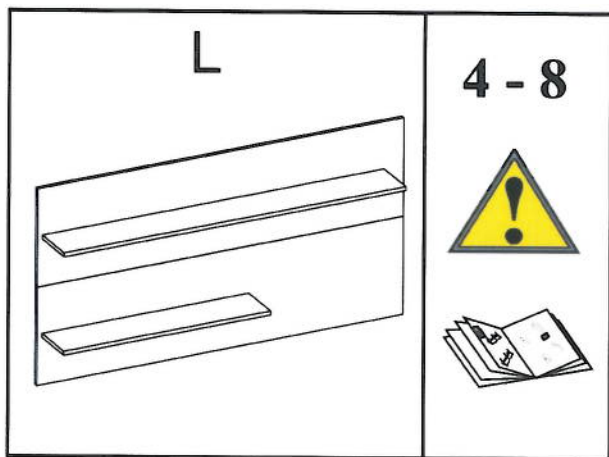



nr	L[mm]	B[mm]	T[mm]	Menge	Cell
1	1500	400	16	1	1/1
2	1500	400	16	1	1/1
3	1400	180	16	1	1/1
4	850	180	16	1	1/1
5	1450	65	16	1	1/1
6	1450	65	16	1	1/1
7	750	65	16	2	1/1



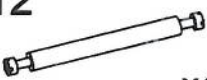
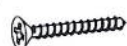

<p>A1</p>  <p>ø7x50 x8</p>	<p>W2</p>  <p>x1</p>	<p>G52</p>  <p>5x11 x6</p>	<p>P10</p>  <p>x3</p>	<p>B1</p>  <p>ø8x30 x12</p>
<p>K1</p>  <p>x8</p>	<p>K12</p>  <p>x4</p>	<p>G36</p>  <p>4x30 x22</p>	<p>I10</p>  <p>ø8 x16</p>	

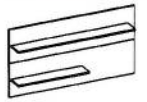

I



I10



x16

K1



x8

B1



ø8x30

x4

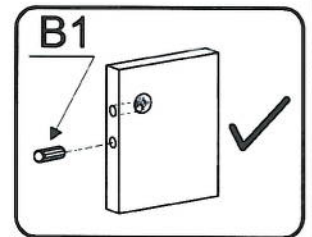
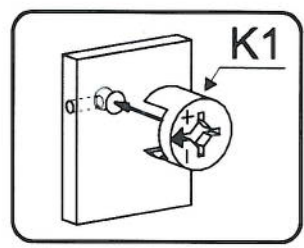
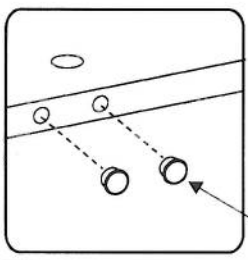
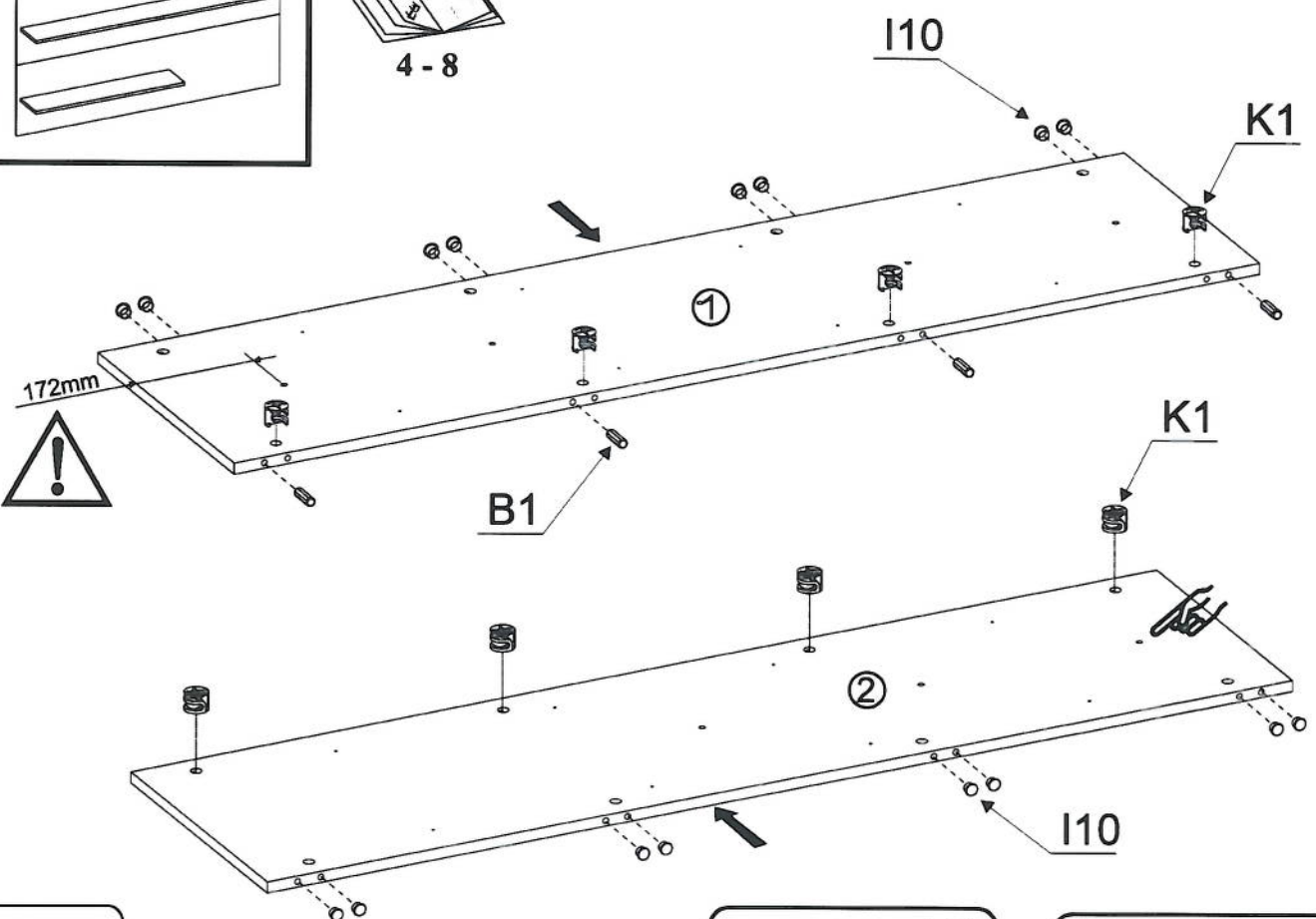
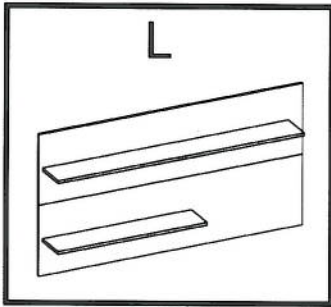

II

B1



ø8x30

x8

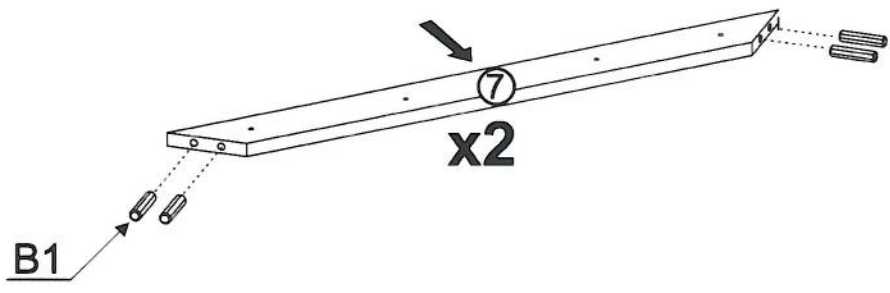

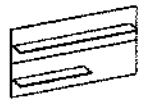

III

G52



5x11

x6

P10



x3

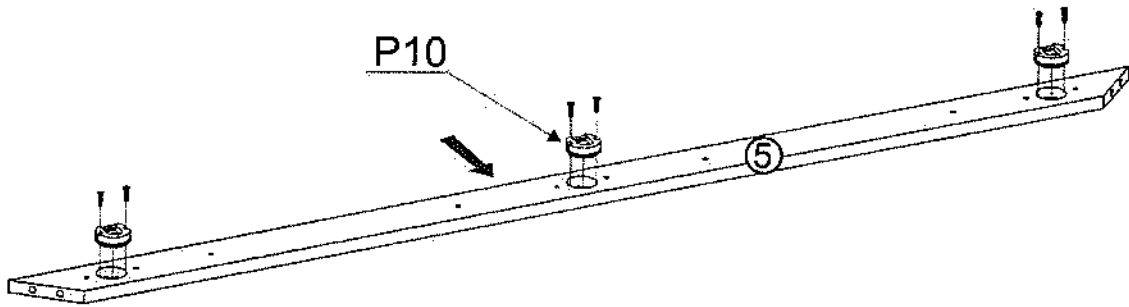

P10

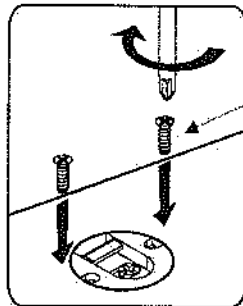
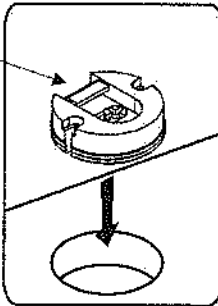

G52

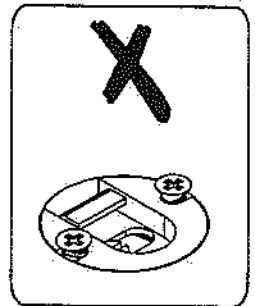
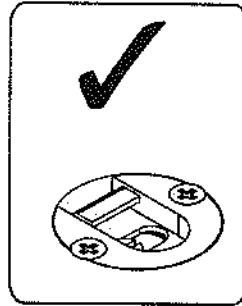

IV

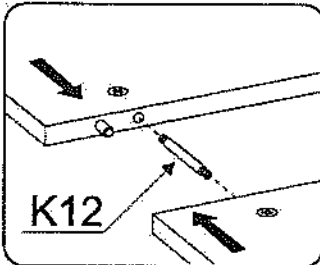

K12

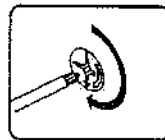
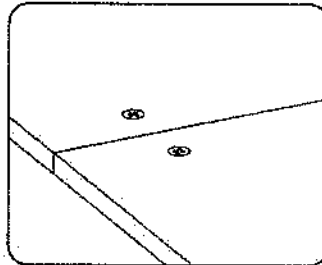

K12



x4

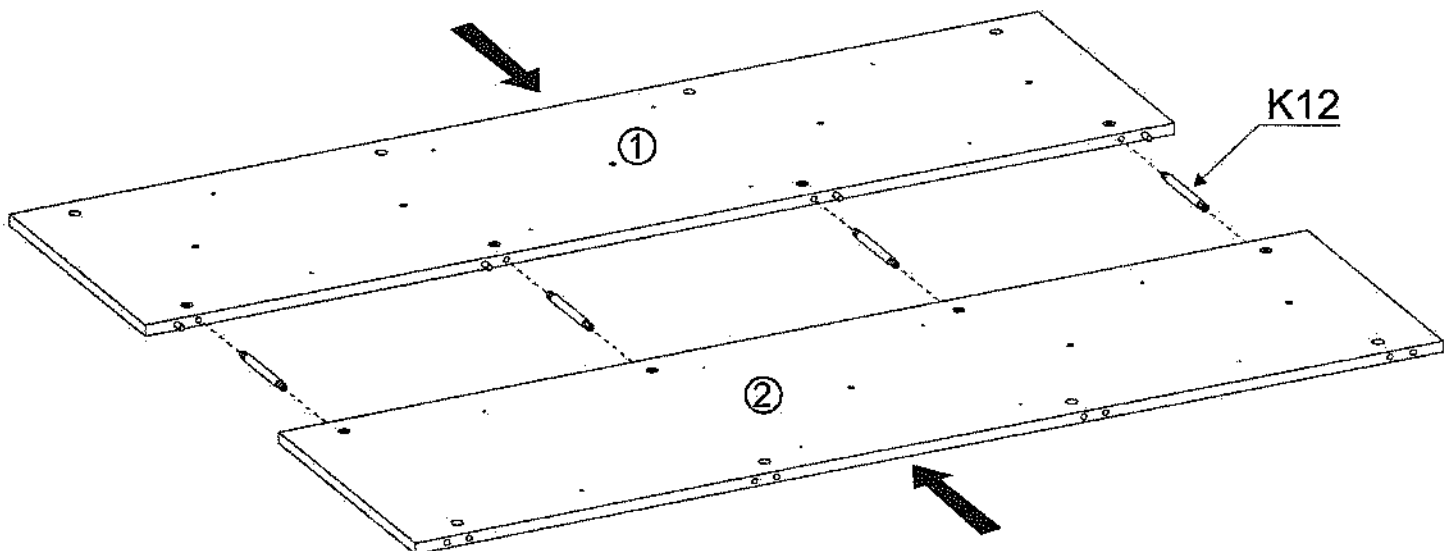

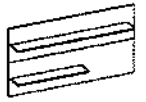

V

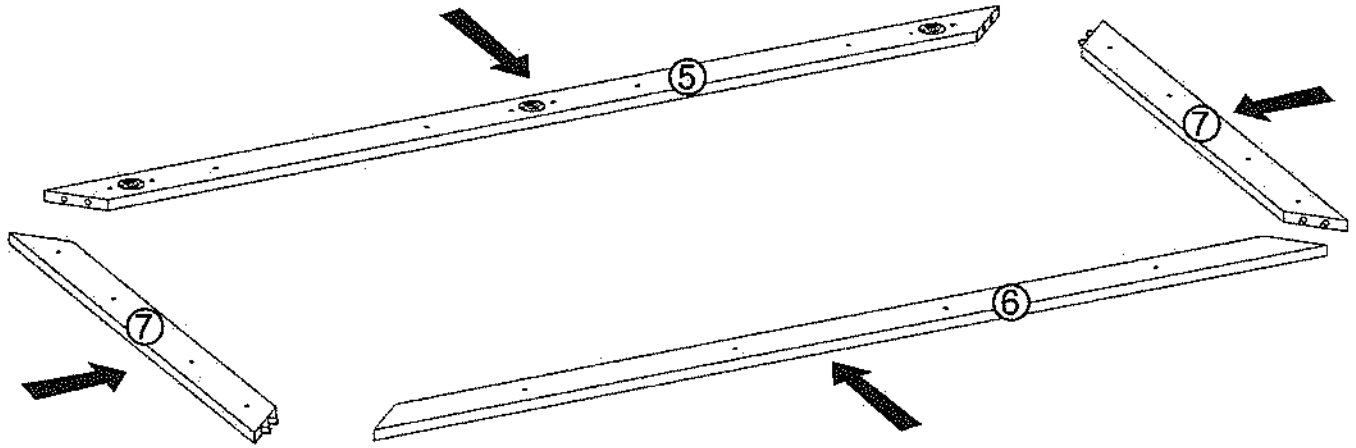

VI

G36

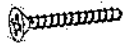

4x30

x22

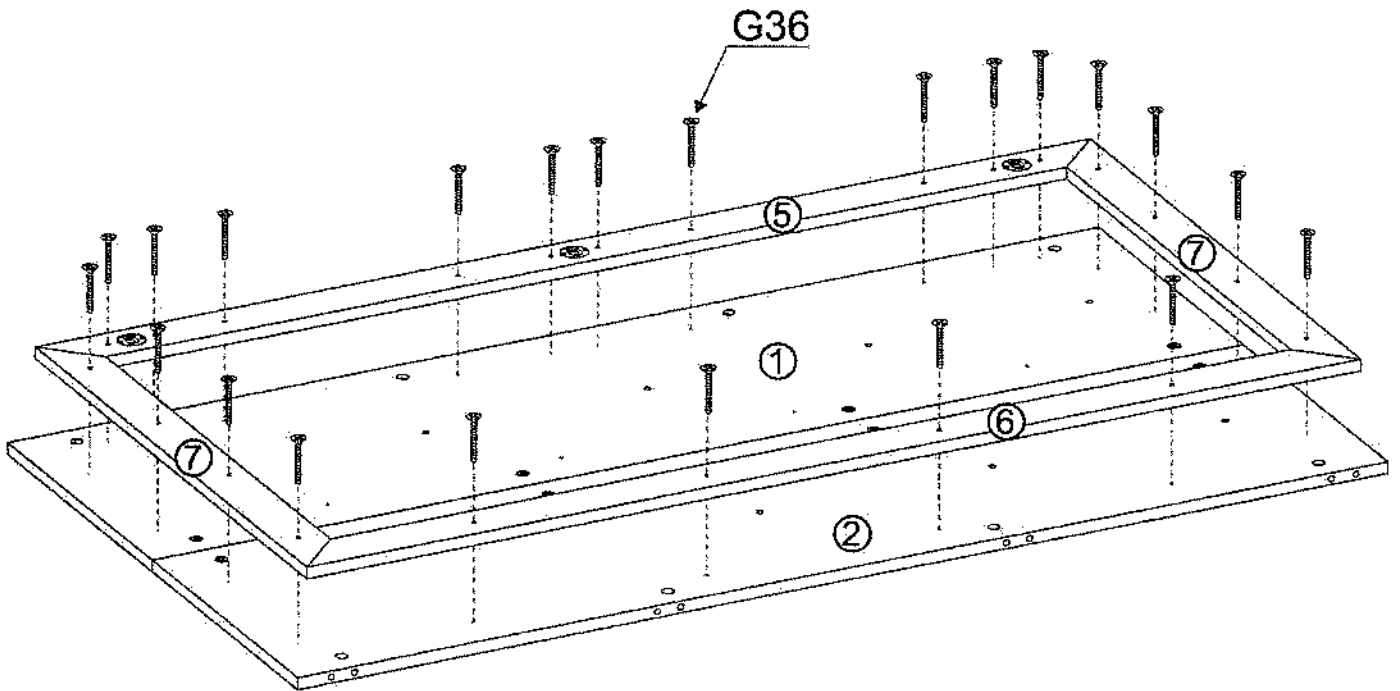

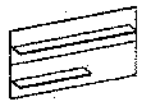

VII

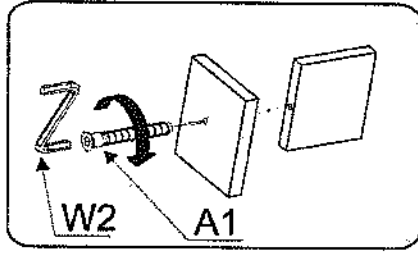

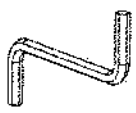
A1	
ø7x50	x8
W2	
	x1

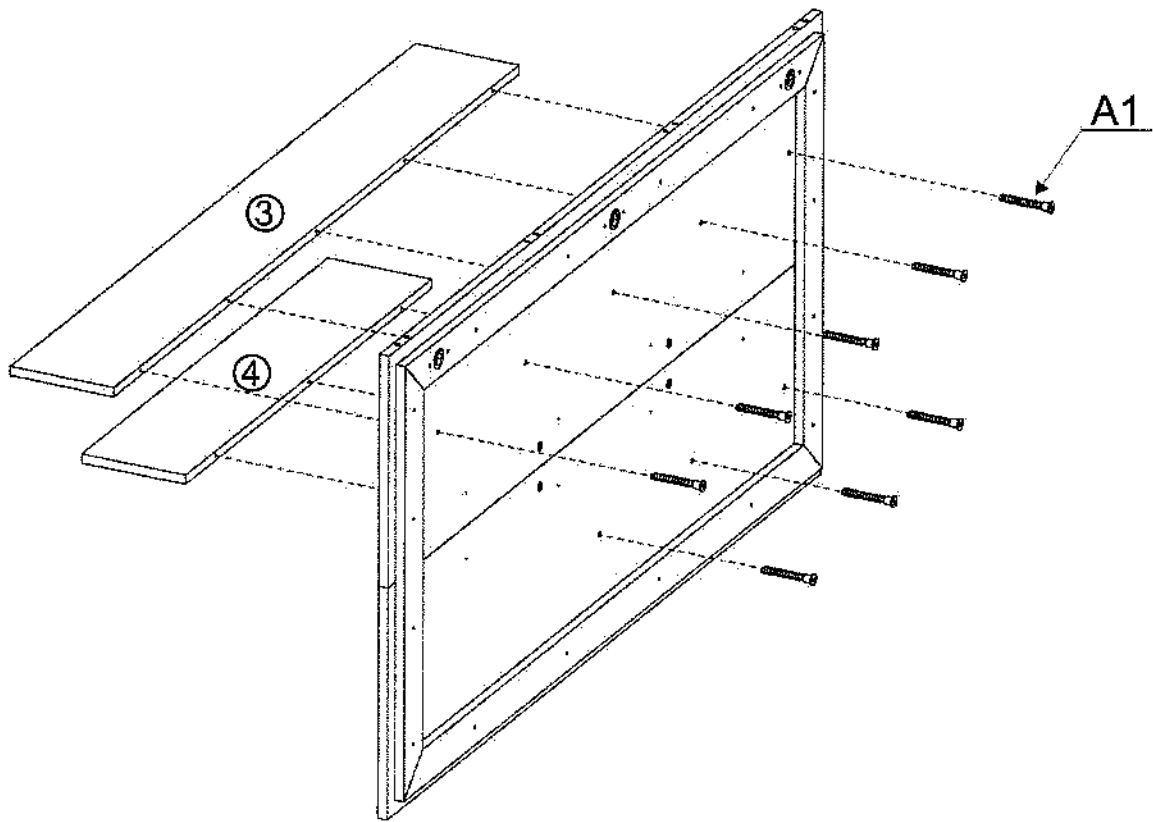

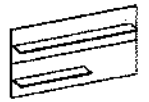

VIII

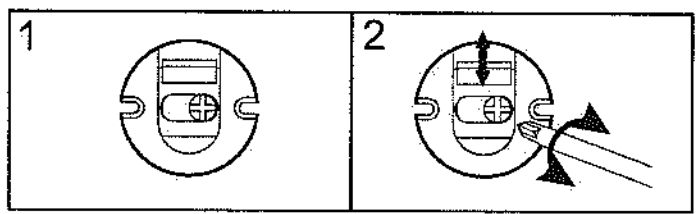
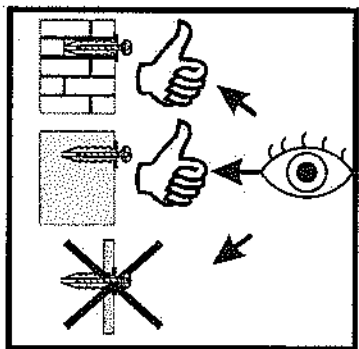
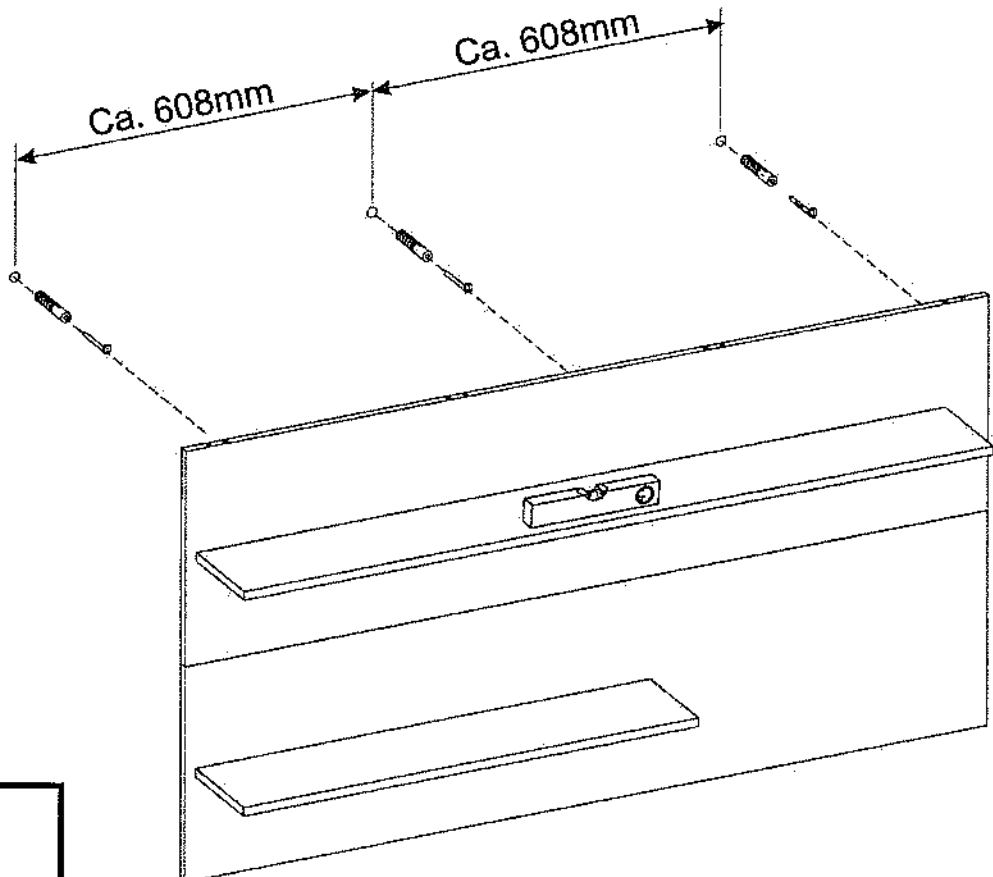
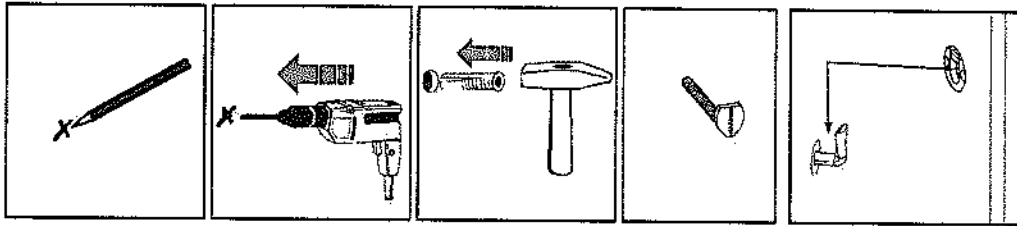
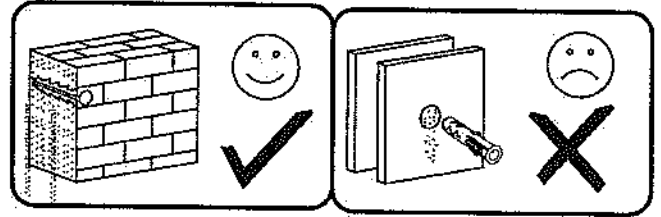
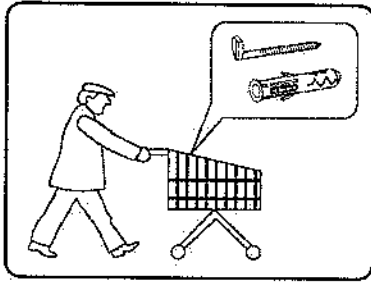

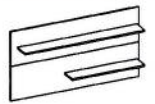

IX



I10



x16

K1



x8

B1

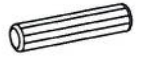

ø8x30

x4

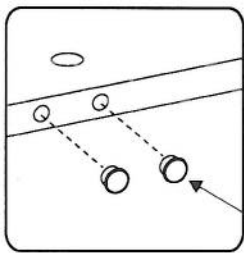
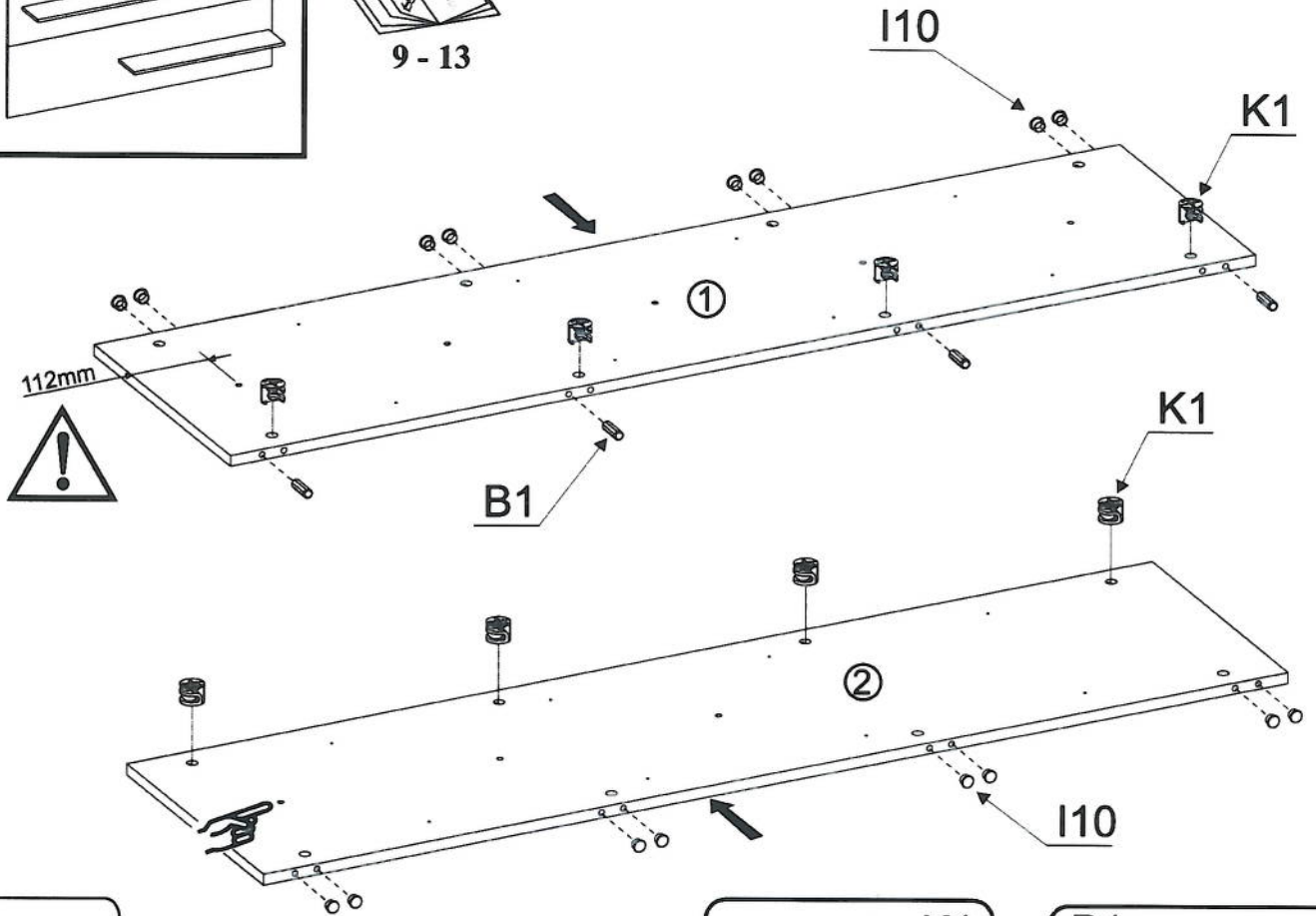
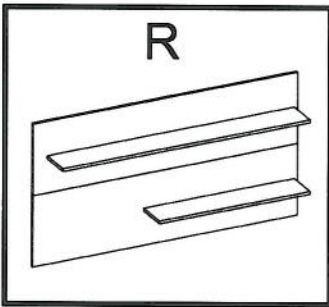

I10

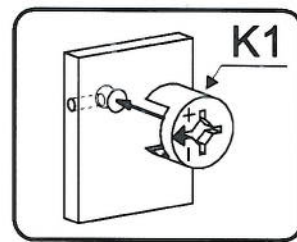

K1

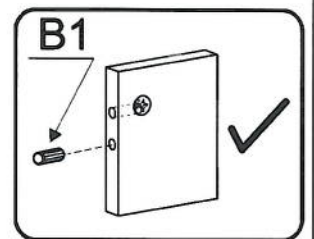

B1

X

B1



ø8x30

x8

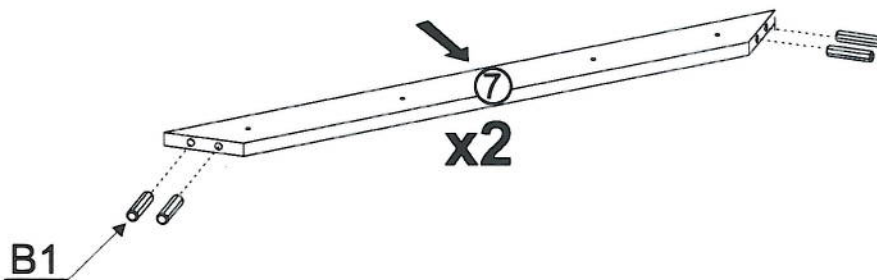



XI

G52

5x11



x6

P10



x3

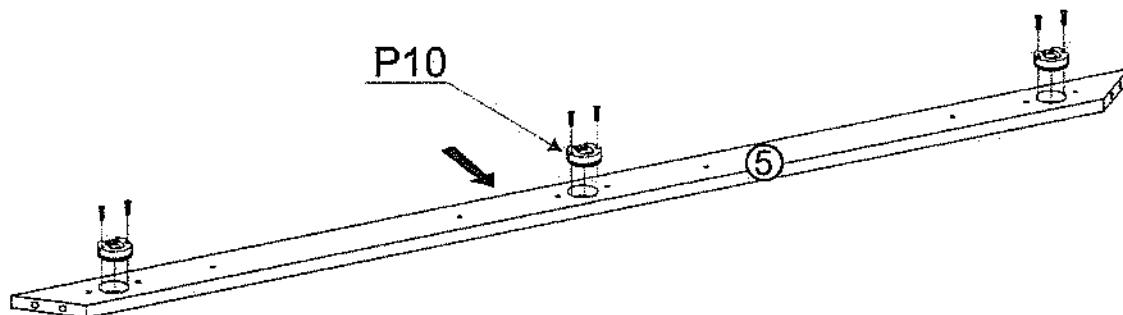

P10

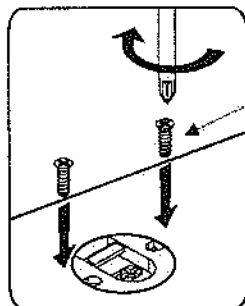
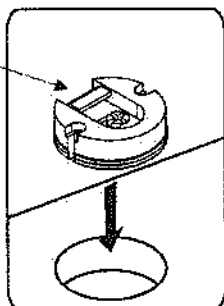

G52

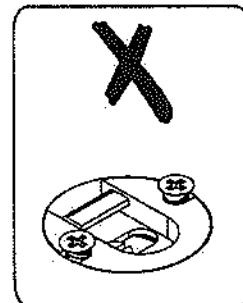
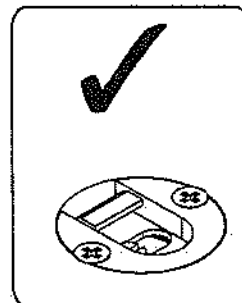

XII

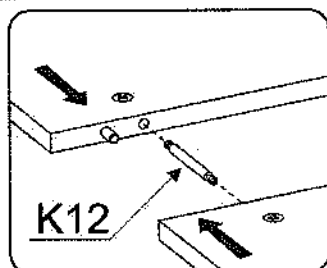

K12

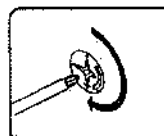
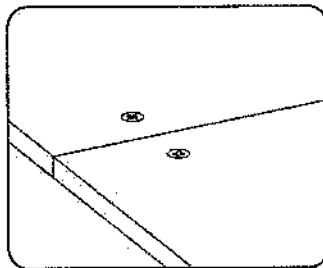

K12



x4

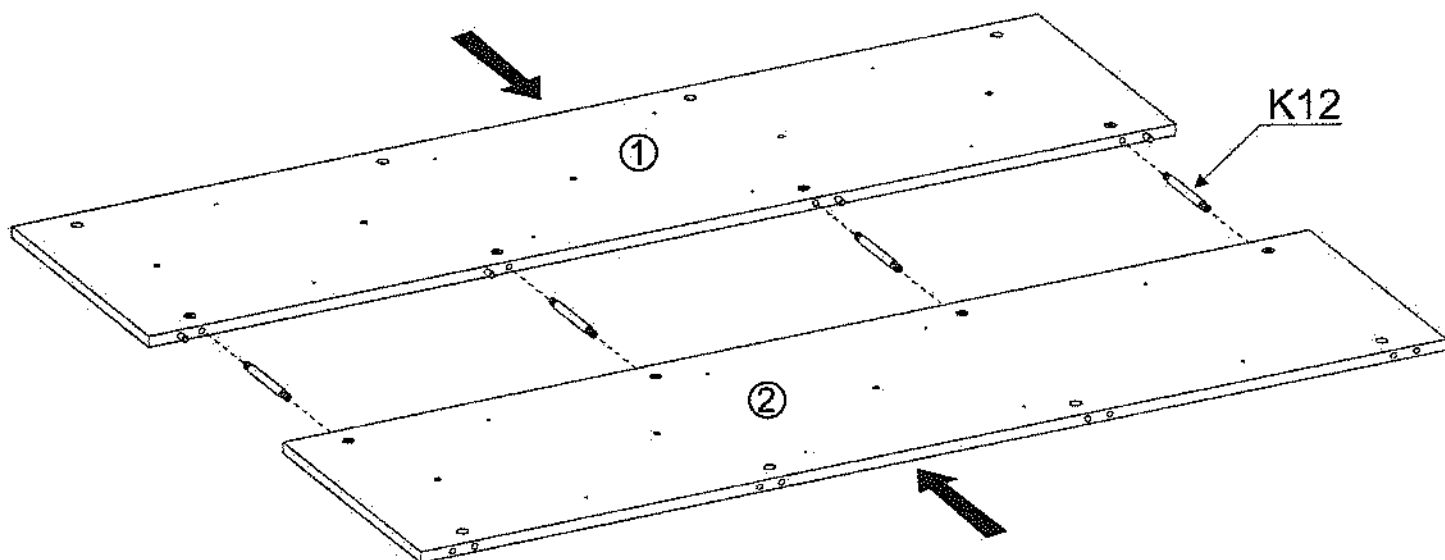



XIII

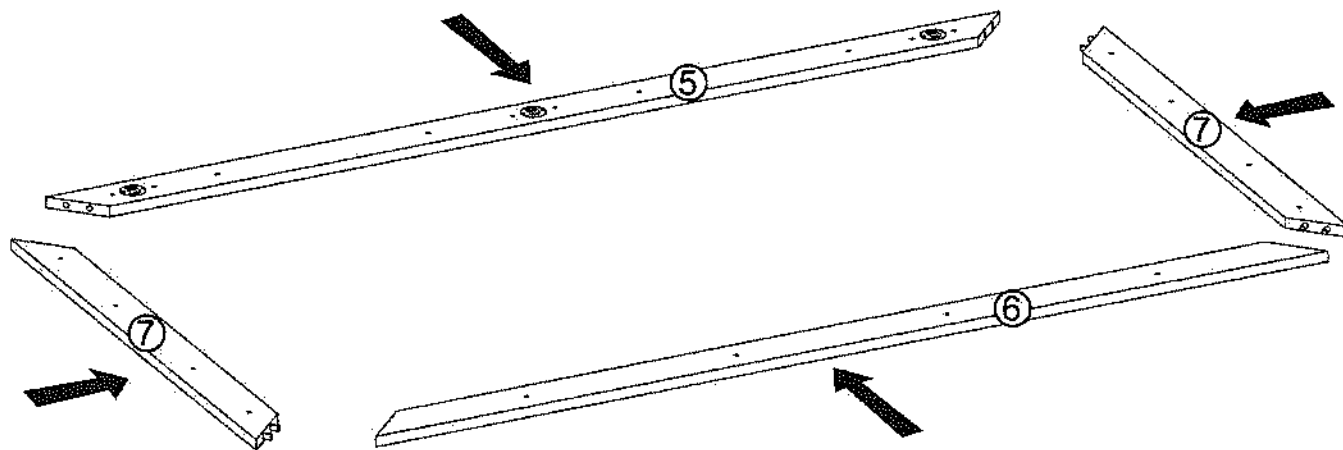

XIV

G36

4x30

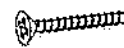

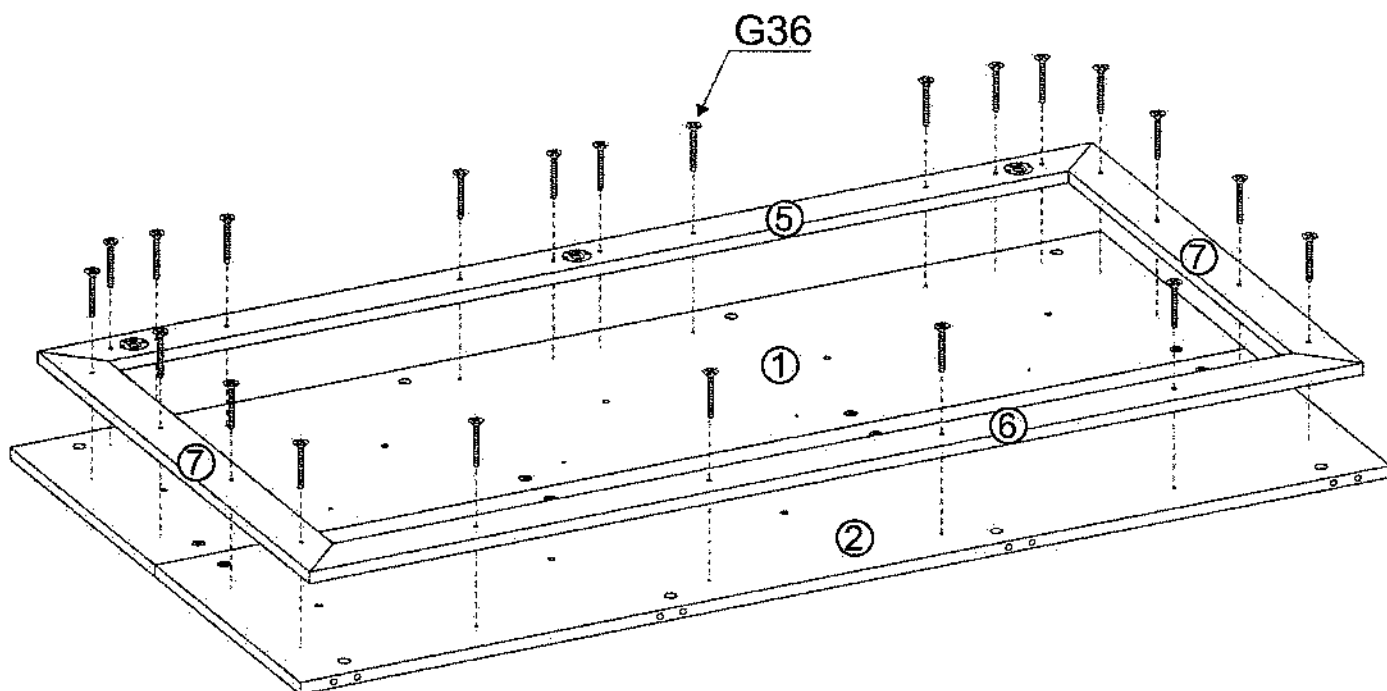

x22

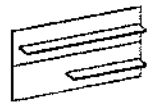

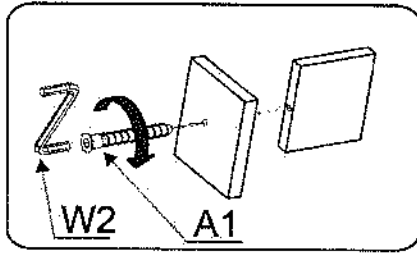

XV

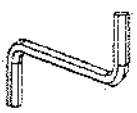

- A1  x8
- $\phi 7 \times 50$
- W2  x1

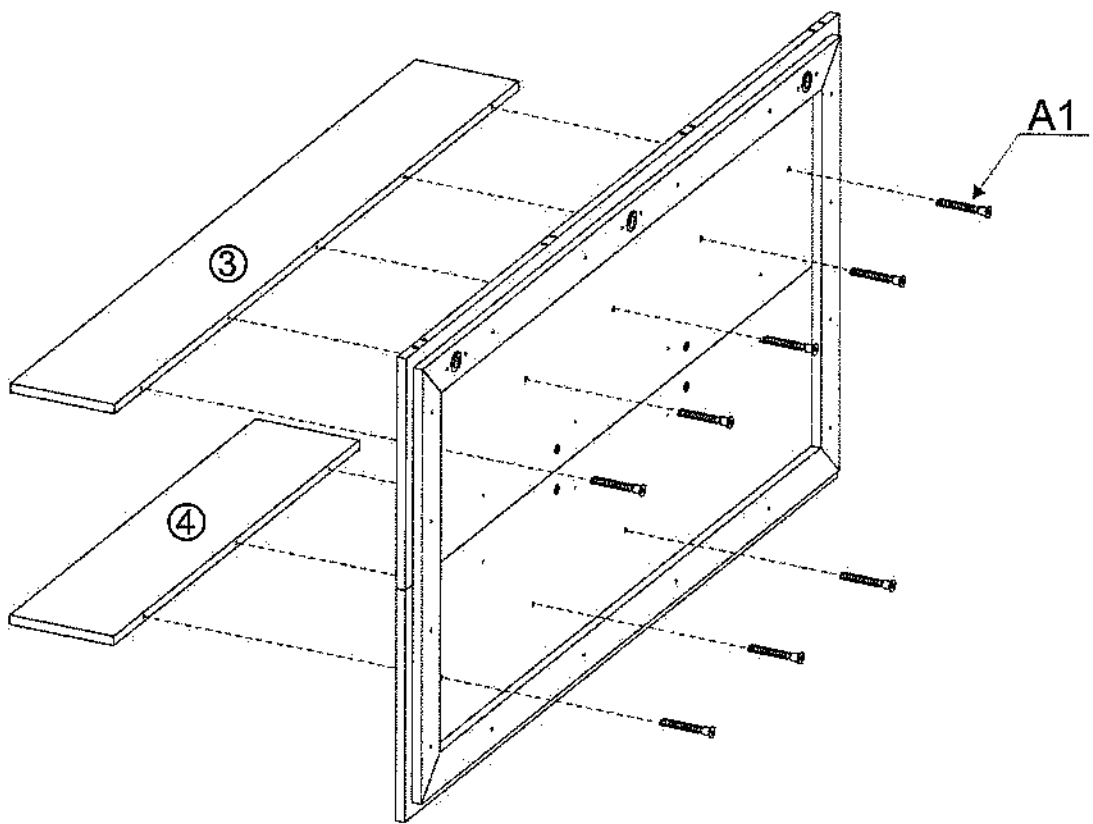

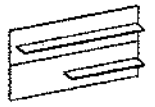

XVI

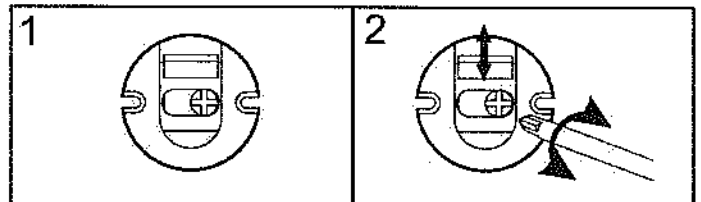
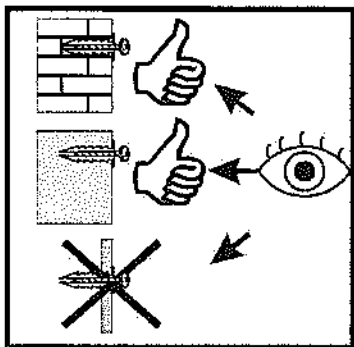
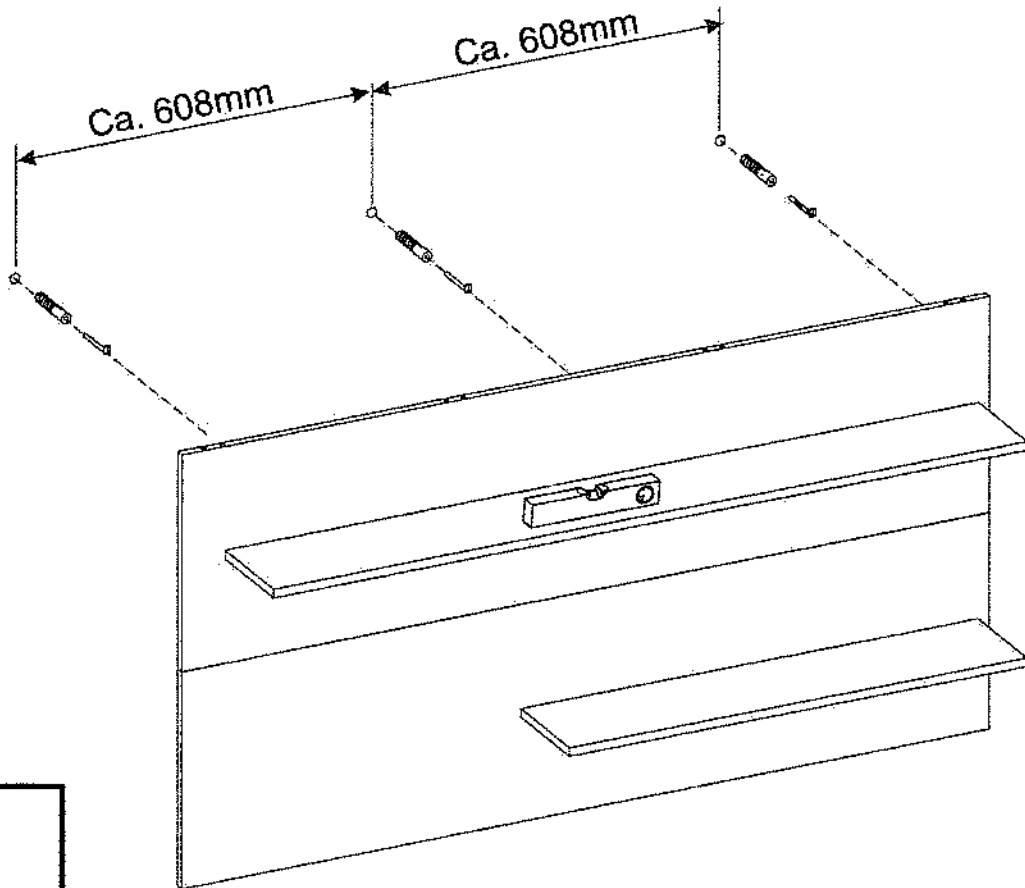
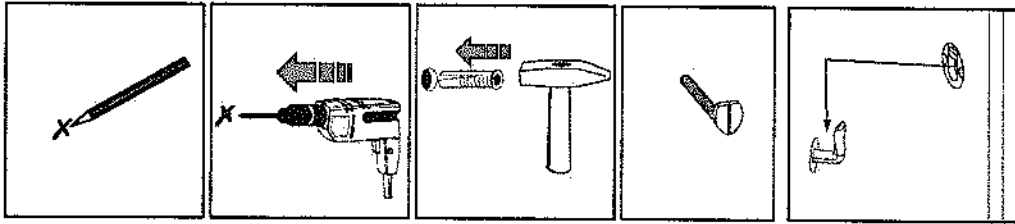
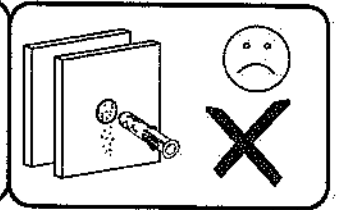
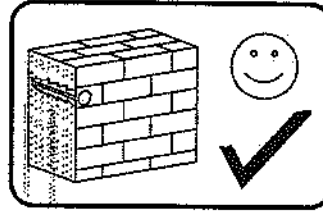
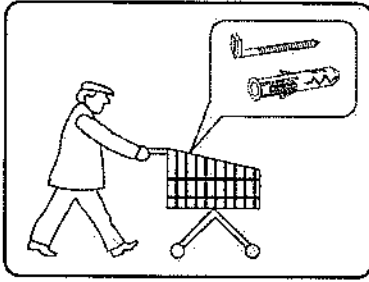

Name • Nom • Nome • Naam • Nazwa • Иméно
• Názov • Név • Denumire • isim • Извание

Nr • No • N° • Номер • Č • Sz

Typ • Type • Tip • Típus • Tipo • Tun

CITY / GIRON

72

D

Unser Direktservice für Beschädigte
Sollte Ihnen ein Beschädigter fehlen, können Sie diese Servicekarte direkt an die untenstehende Adresse mailen. Wir können allerdings nur Beschädigte auf diesem Wege verschicken. Sollten Sie eine andere Beanstandung an Ihrem Möbelstück haben, so wenden sie sich bitte direkt an Ihr Möbelhaus.

GB

Our direct order service for fitting
If a fitting part is missing, you can e-mail this service card directly to the address below. However, we can only send fitting parts in this way. If you have any other cause for complaint concerning your item of furniture, please contact your furniture store directly.

CZ

Naše přímé služby pro kování
Chybí-li vám nějaký díl z kování, můžete tuto servisní kartu odeslat e-mailem přímo na níže uvedenou adresu. Touto cestou však můžeme zoslat jen díly kování. Pokud byste reklamovali jiný díl nábytku, obraťte se přímo na svého prodejce nábytku.

F

Bien étudier la notice de montage
Si vous manquez une ferrure, veuillez envoyer directement la présente carte service à l'adresse e-mail indiquée ci-dessous. Cependant, ceci nous permet uniquement d'envoyer des ferrures. Pour tout autre type de réclamation concernant votre meuble, veuillez contacter directement votre magasin d'ameublement.

I

Il nostro servizio diretto per l'ordine della ferramenta
Qualora Vi dovesse mancare un pezzo di fissaggio, allora Vi preghiamo di inviare questa carta di servizio immediatamente all'indirizzo sottostante. Possiamo inviare i pezzi di fissaggio solamente per mezzo di questo procedimento. Qualora dovete avere qualche altra reclamazione in merito al mobile, allora Vi preghiamo di rivolgerVi direttamente al Vostro Negozio di mobili.

BG

Нашата директна услуга за обкова
Ако липсват части от комплекта, попълнете настоящата сервисна карта и я изпратете на e-mail адреса, посочен по-долу. По този начин можем да доставяме само липсващи елементи от обкова. Ако установите други дефекти по мебелите, Ви съветваме да се обърнете към мебелната къща/магазин. от който сте закупили стоката.

NL

Onze directservice voor leuze onderdelen
Wanneer er een onderdeel ontbreekt, kunt u deze servicekaart direct aan ons stuurend e-mailadres sturen. Wij kunnen langs deze weg echter alleen beslagdelen versluren. Mocht u een ander probleem aan uw meubel hebben, verzoeken wij u contact op te nemen met uw meubeldealer.

PL

Nasz bezpośredni serwis części montażowych
Jeżeli brakuje części koniecznych do montażu, prosimy o przesłanie nam niniejszej karty serwisowej na niżej podany adres e-mailowy. W ten sposób możemy przesyłać Państwu tylko brakujące części. W przypadku innych reklamacji dotyczących mebla, prosimy zgłosić się do salonu meblowego, w którym został dokonany zakup.

HR

Servis za okove
U slučaju da nedostaje neki od dijelova molimo vas da ne dolje navedenu mail adresu pošaljete ovaj servisni obrazac. Na ovaj način mogu se dostaviti samo okovi. U slučaju da imate dodatna prigovore vezane uz komad namještaja molimo vas da se obratite izravno trgovini namještaja gdje je isti kupljen.

HU

Direktizolnálóunk vasalatók esetén
Ha hiányzik egy vasalat, ezt a kártyát közvetlenül elküldheti az alábbi látható címre. Azonban csakis vasalatókat tudunk így küldeni. Amennyiben másfajta reklamáció áll fenn bútoráruját illetően, forduljon közvetlenül a bútorházhöz.

SK

Náš priamy servis pre časti kovania
Ak by Vám chýbala nejaká časť kovania, môžete poslať túto servisnú kartu poslať e-mailom na nižšie uvedenú adresu. Diely kovania vieme poslať iba týmto spôsobom. Ak by ste mali inú reklamáciu ohľadom Vášho nábytku, obráťte sa priamo na Vašu predajňu nábytku.

SLO

Naša direktna usluga storitve za okovje
Če vam manjka kakšno okovje, lahko to serviso kartico pošljete po e-pošti direktno na spodnji naslov. Po tej poti vam lahko pošljemo samo okovje. Če želite reklamirati kakšen drug del pohištva, se obrnite neposredno na vašo trgovino pohištva.

RO

Serviciul nostru direct pentru feronerie
In cazul in care va lipsesc o piesa de feronerie puteti sa trimitezi direct acest card de service prin e-mail la adresa de mai jos. Noi nu putem expedia piese de feronerie decat pe aceasta cale. Dacã aveți o altã reclamatie referitoare la piesa de mobilier, atunci va rugãm sã vã adresati direct la magazinul dvs. de mobilier.

RUS

Наш прямой сервис для поставок фурнитуры
Если ожидается, что Вам не хватает той или иного элемента фурнитуры, Вы можете отправить сервисную карту по факсу непосредственно на нижеприведенный адрес электронной почты. Однако, таким образом мы можем пересылать лишь фурнитуру. Если же у Вас возникнут иные претензии относительно приобретенной мебели, пожалуйста, обращайтесь непосредственно в организацию, осуществляющую продажу.

S

Vår direktservice för beslagdelar
Om du saknar en beslagdel kan du skicka detta servicekort direkt till e-postadressen som anges nedan. Tank på att detta är den enda möjligheten att skicka beslagdelar till dig. Om du vill reklamera din möbel av en annan anledning måste du kontakta ditt möbelhus direkt.

ES

Nuestro servicio directo para accesorios
Si le falta algún accesorio, puede enviar esta tarjeta de servicio directamente a la siguiente dirección. No obstante, por esta método solo podemos enviar accesorios. Si tiene alguna otra objeción sobre su mueble, consulte directamente con su mueblería.

TR

Donatılar için doğrudan servisimiz
Bir donatınız eksikse bu servis kartını doğrudan aşağıda bulunan adrese doğrudan mail yazabilirsiniz. Sadece bu yolla donatılar gönderiliriz. Mobilyanızda başka şikayetleriniz varsa lütfen doğrudan mobilya satışınıza danışın.

nr	L[mm]	B[mm]	T[mm]	Menge	Coll
1	1500	400	16	1	1/1
2	1500	400	16	1	1/1
3	1400	180	16	1	1/1
4	850	180	16	1	1/1
5	1450	65	16	1	1/1
6	1450	65	16	1	1/1
7	750	65	16	2	1/1

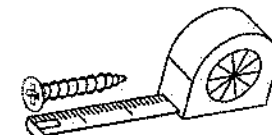
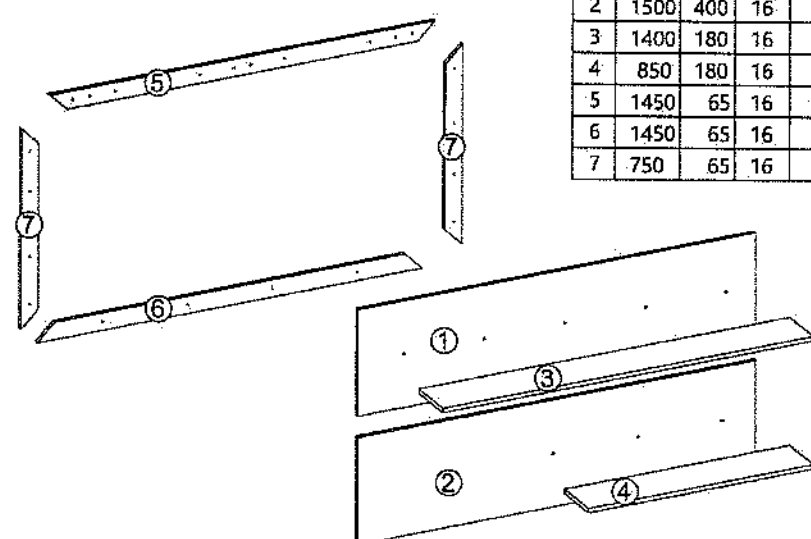

A1 ø7x50 X...	W2 X...	G52 5x11 X...
P10 X...	B1 ø8x30 X...	K1 X...
K12 X...	G36 4x30 X...	I10 ø8 X...

