

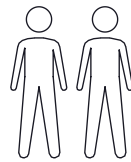

0 : 50

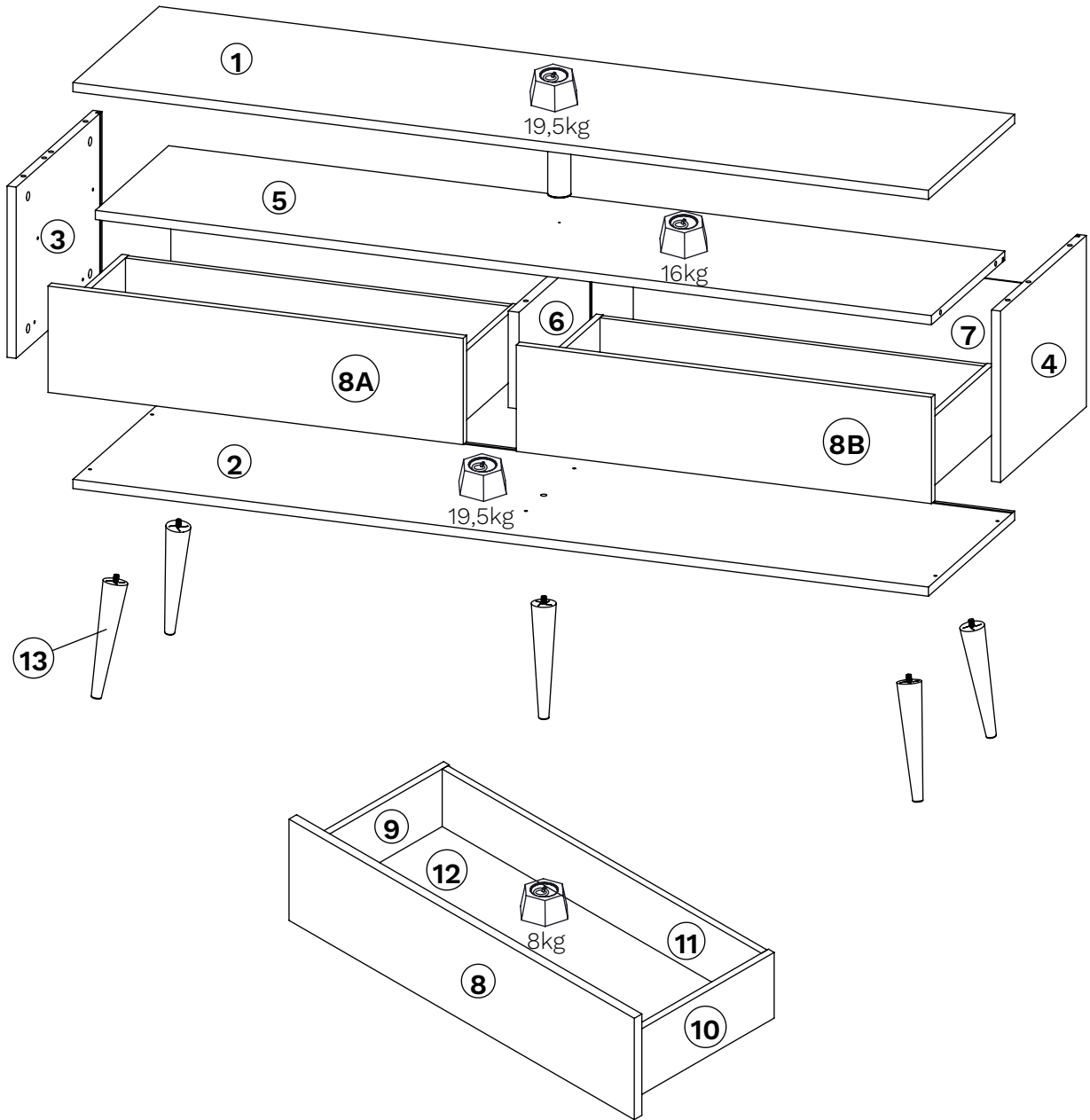

x 2



○	x	mm	
1	1	1500 x 400 x 16	2
2	1	1500 x 400 x 16	2
3	1	398 x 298 x 16	2
4	1	398 x 298 x 16	2
5	1	1466 x 340 x 16	2
6	1	338 x 168 x 16	2
7	2	734 x 180 x 4	2
8	2	728 x 185 x 16	2
9	2	295 x 120 x 12	1
10	2	295 x 120 x 12	1
11	2	676 x 120 x 12	1
12	2	688 x 289 x 4	1
13	5	Ø41x212	1

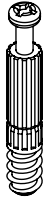
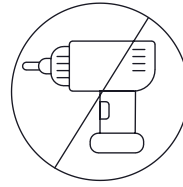
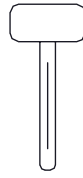
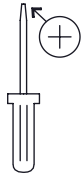

Ø7 x 41mm

BAA x 18



AAA x 18

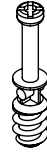

Ø7 x 32mm

BAC x16



AAC x16

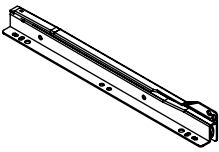

OHG x2

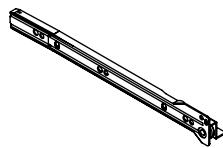

OHH x2



Ø3,5 x 12mm

GGQ x8

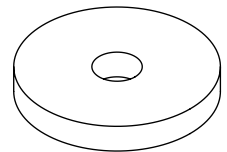

ERA x1



EDC x4



EFC x4

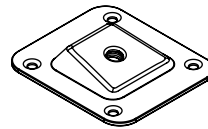

SAJ x4



Ø5x16mm

GGL x16

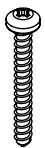

Ø4 x 40mm

GGX x2



Ø6 x 11mm

FB x8

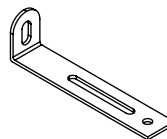

NET x1





Ø4 x 16mm

GGS x1



RWD x 1
RWC x 2

1

BAA x4  Ø7x41mm	RWC x1  Ø4x40mm	GGX x1  Ø4x40mm
--	--	--

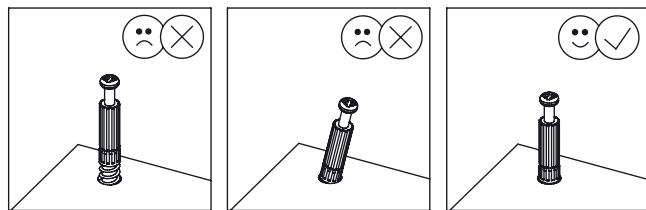
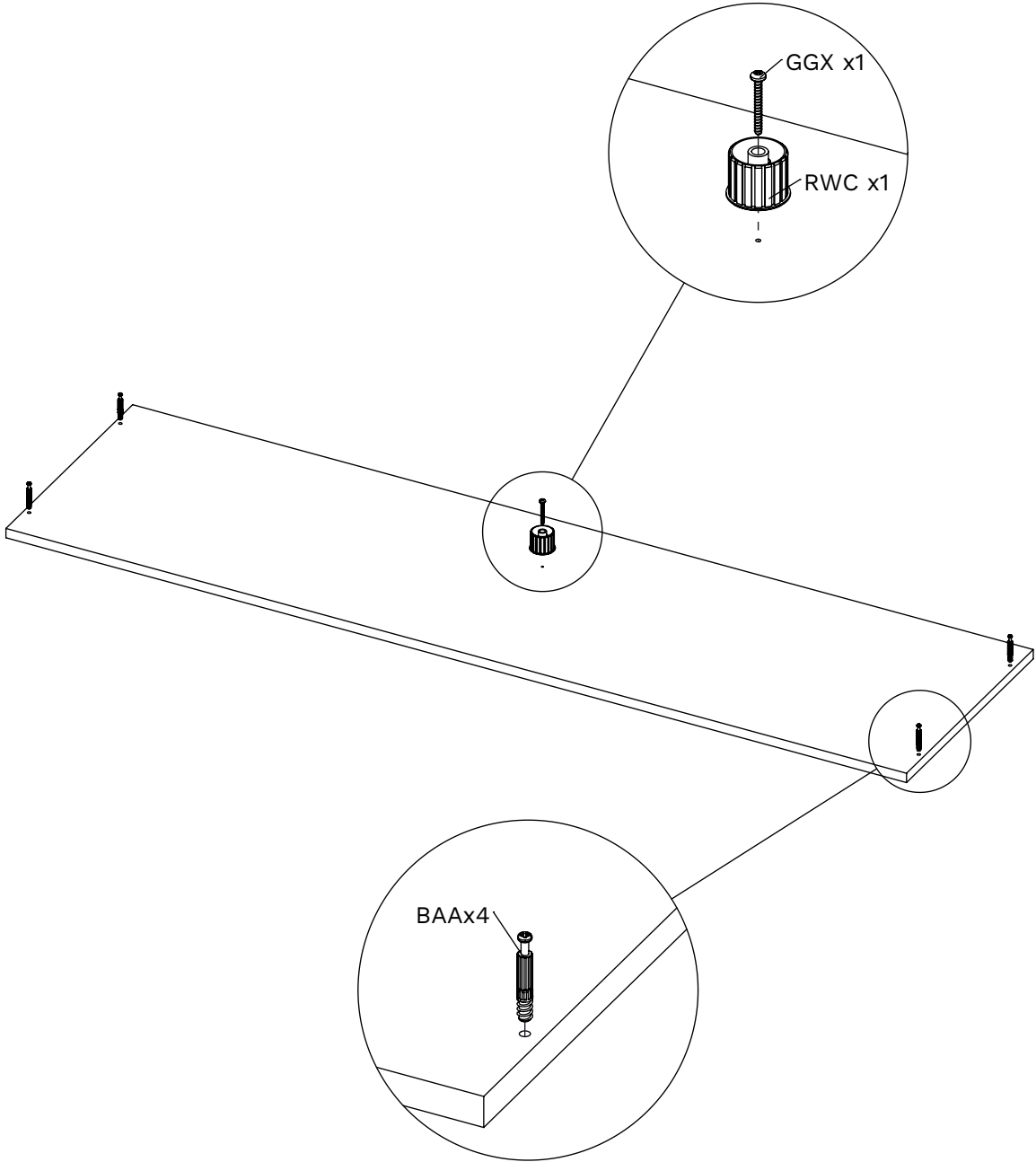
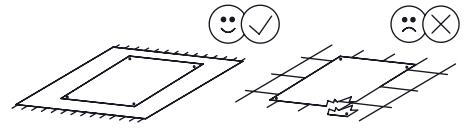

2

BAA x4



Ø7x41mm

AAA x12

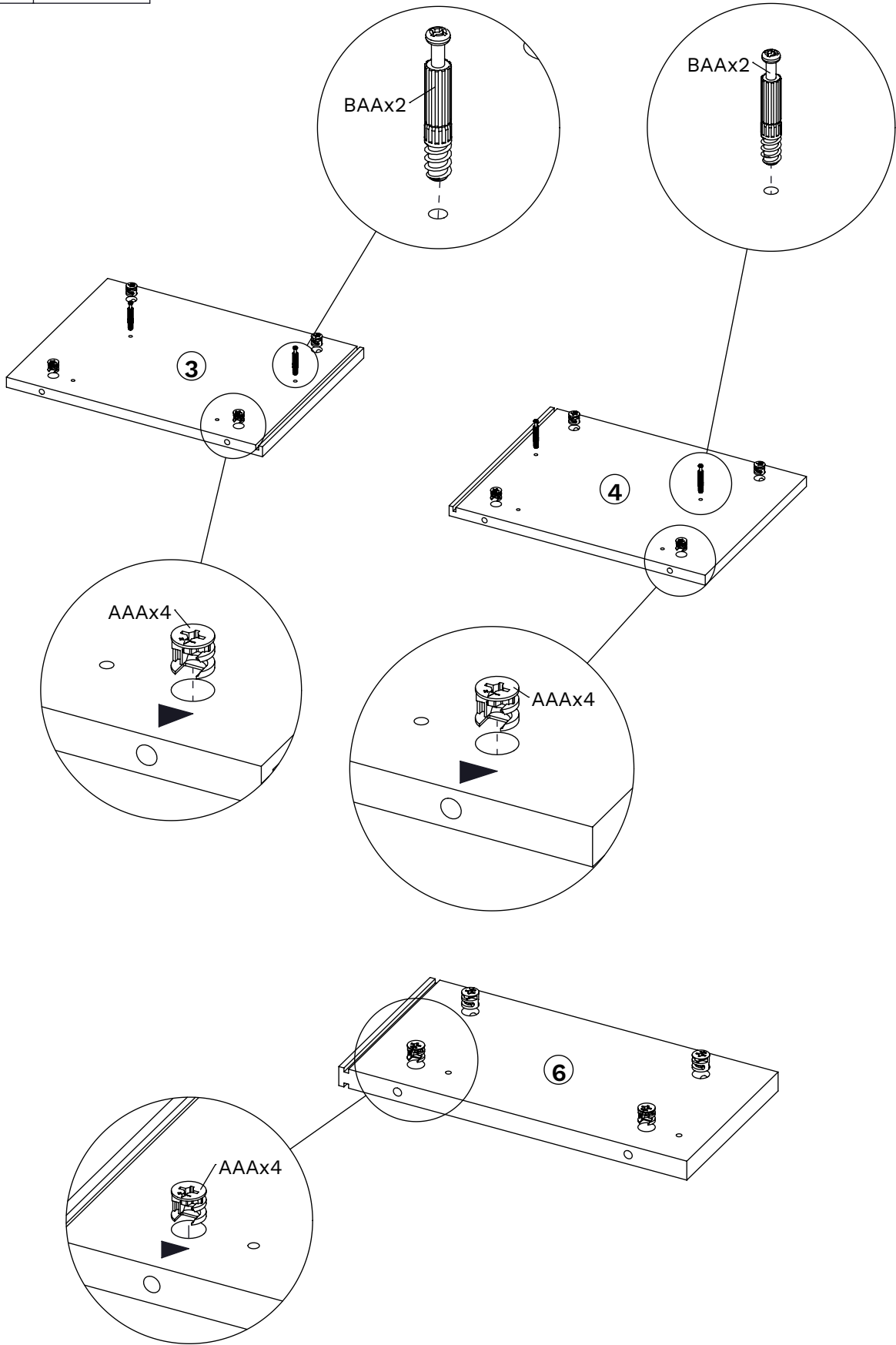
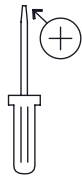

3

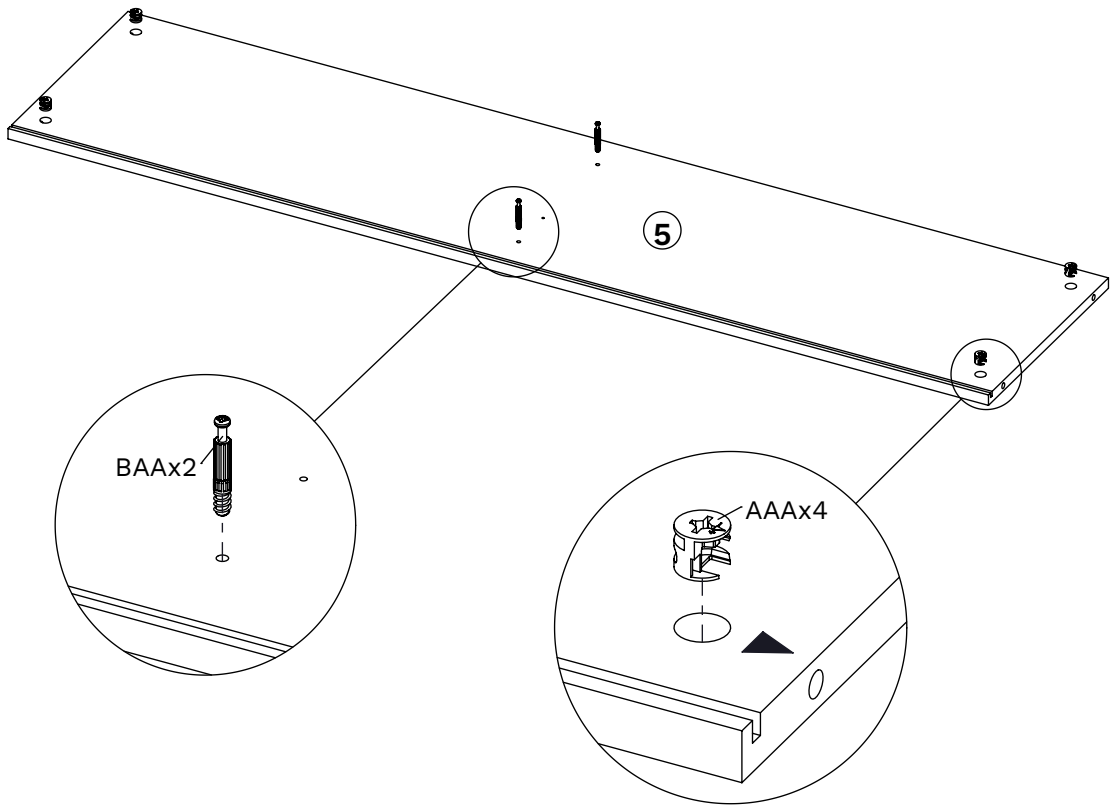
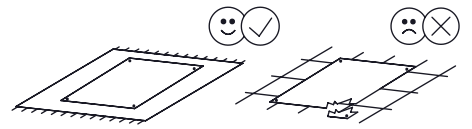
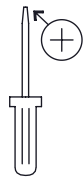
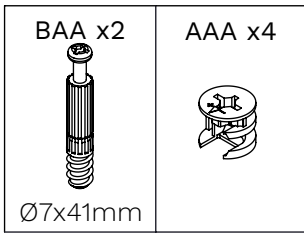

4

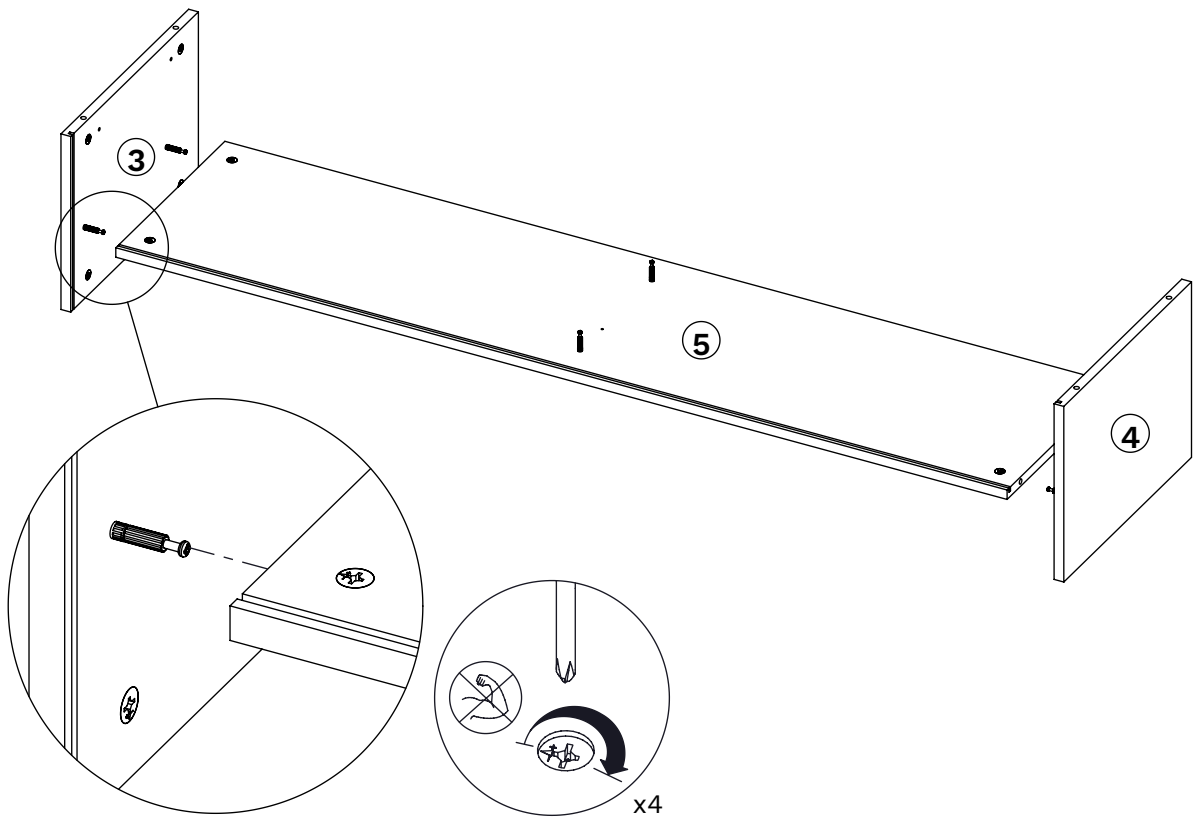
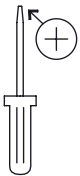

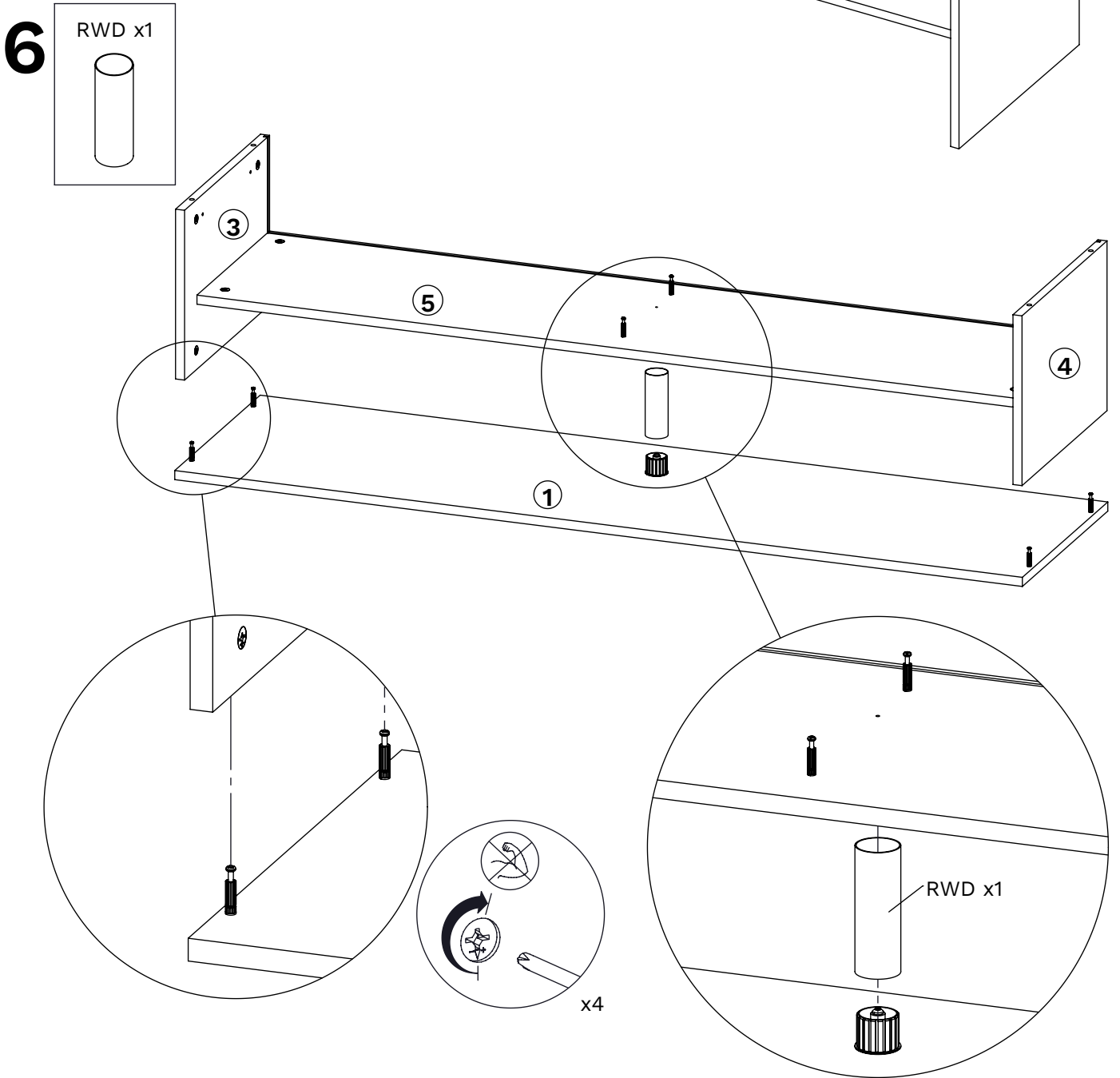
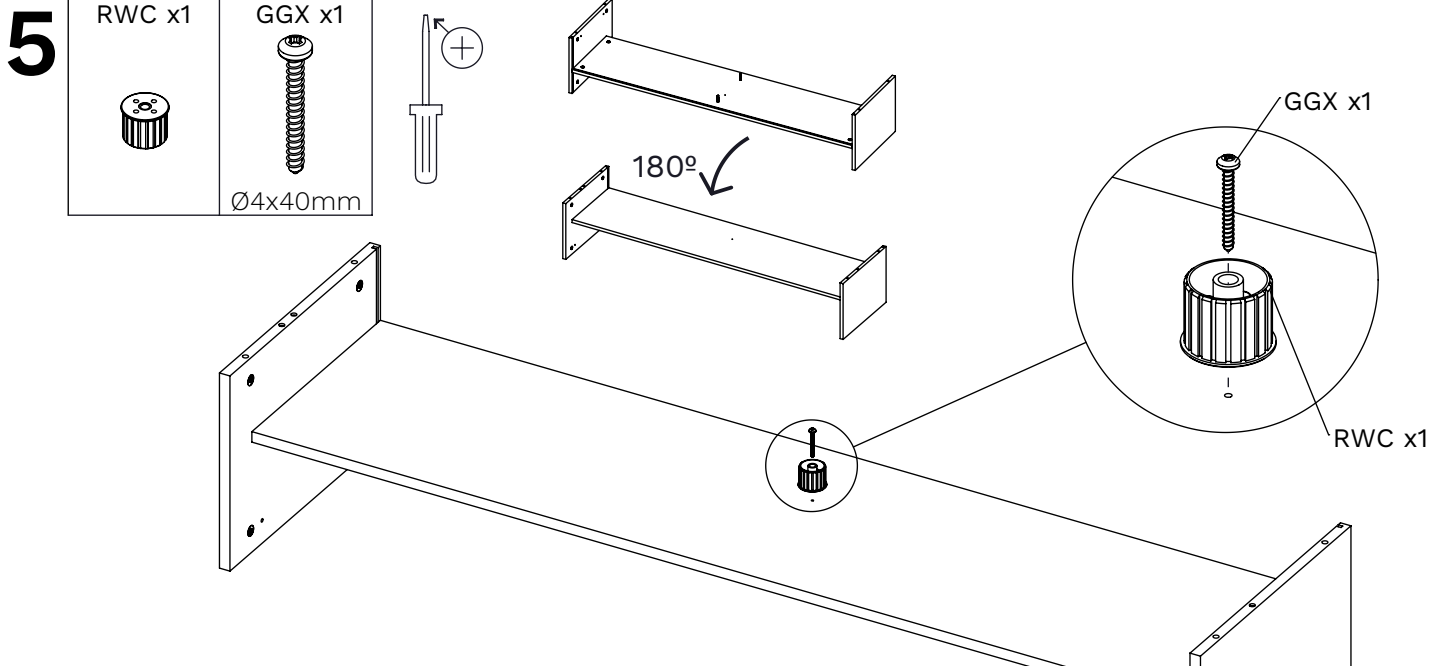

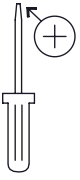
7 

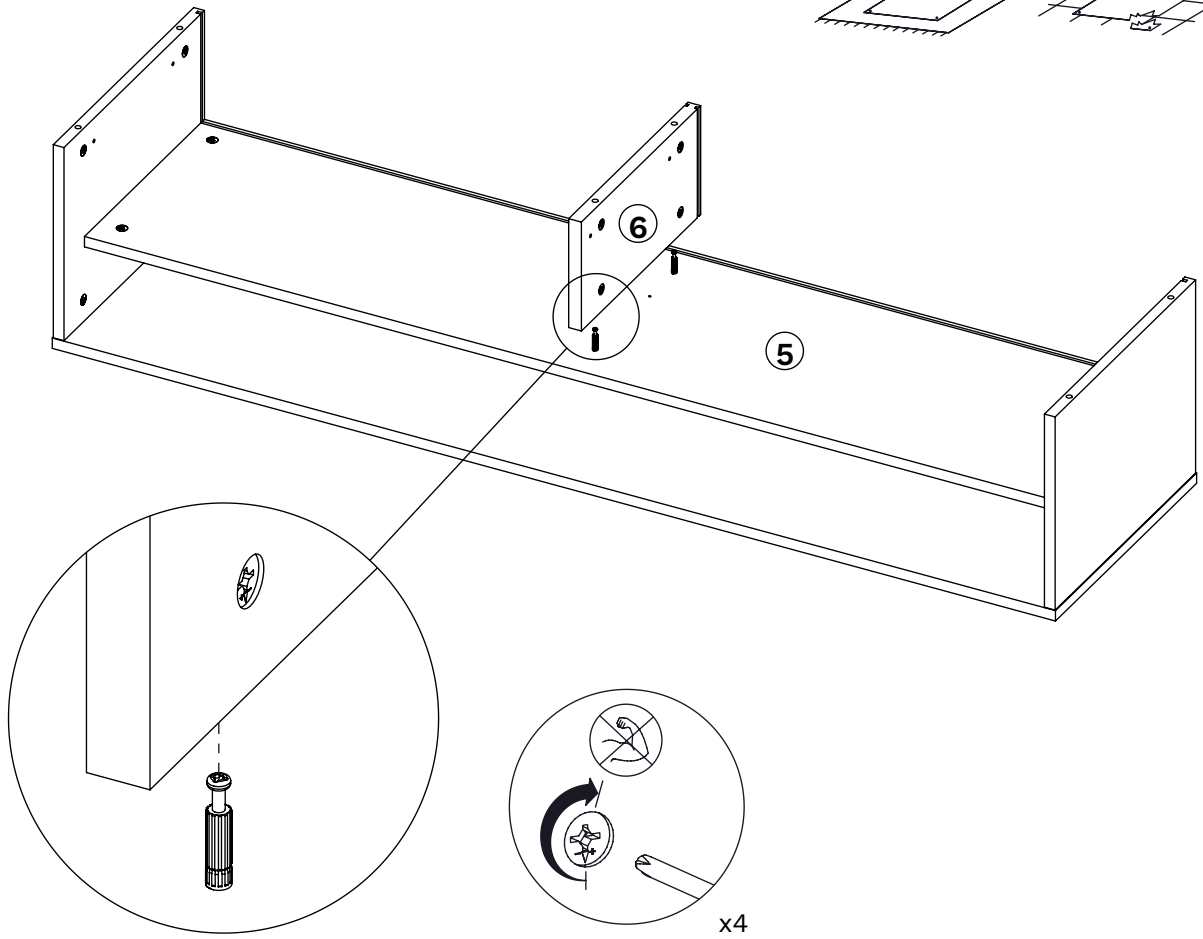
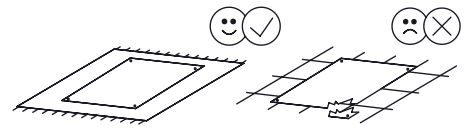

8

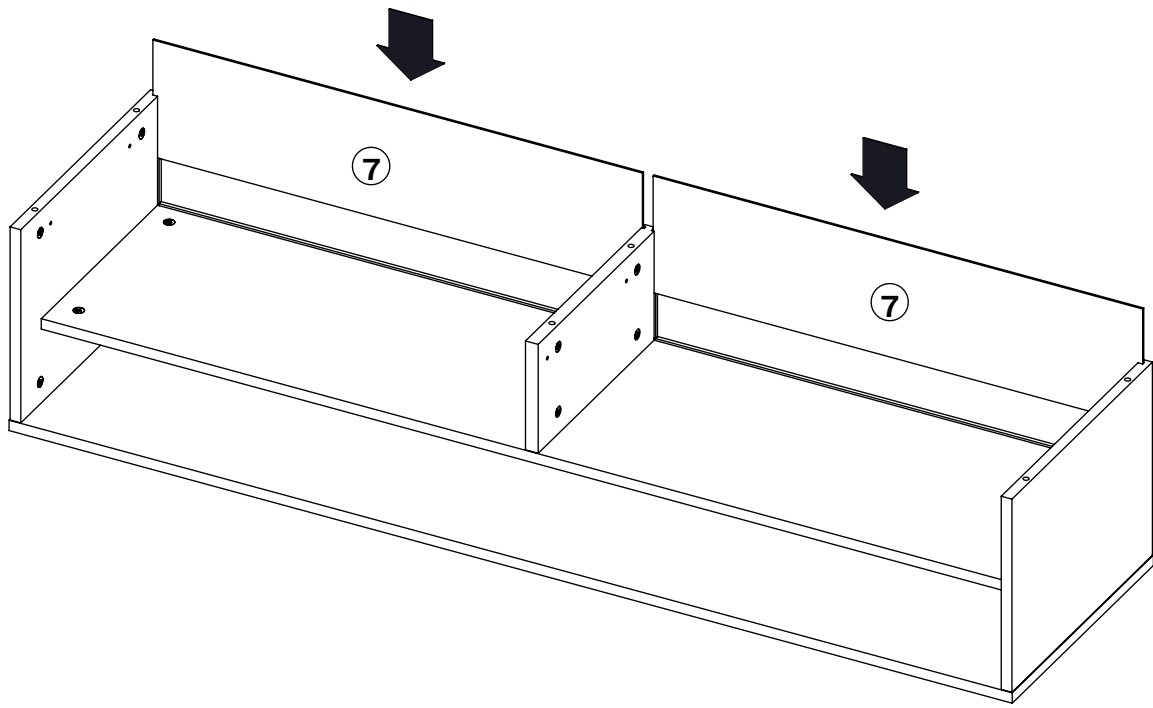

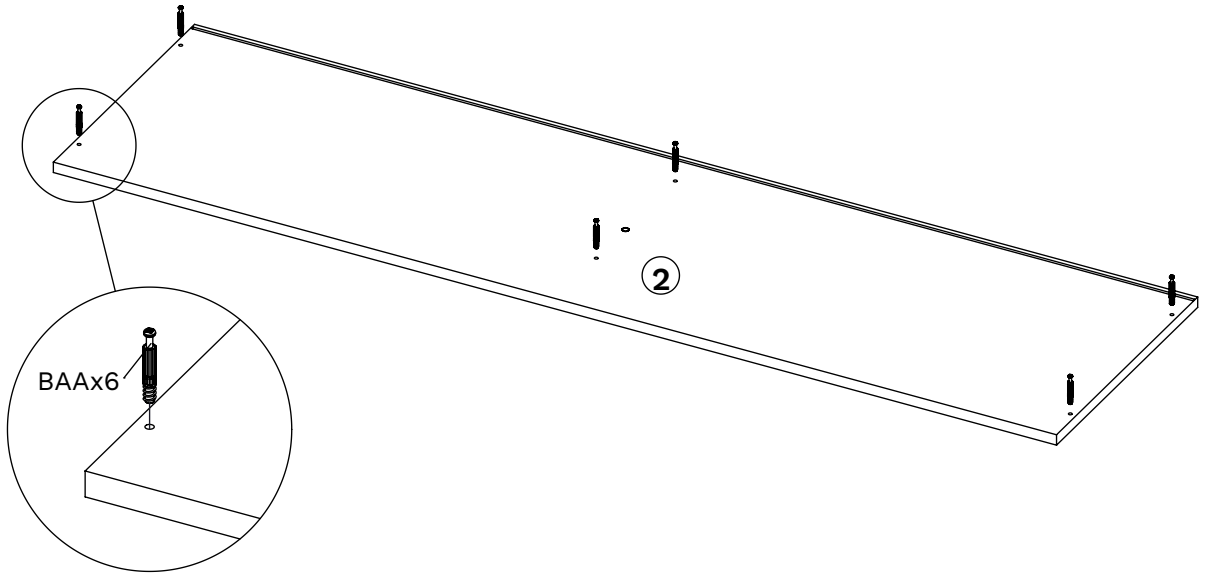
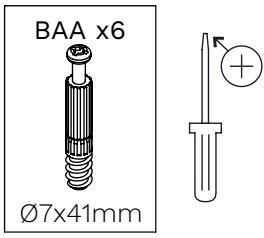

9

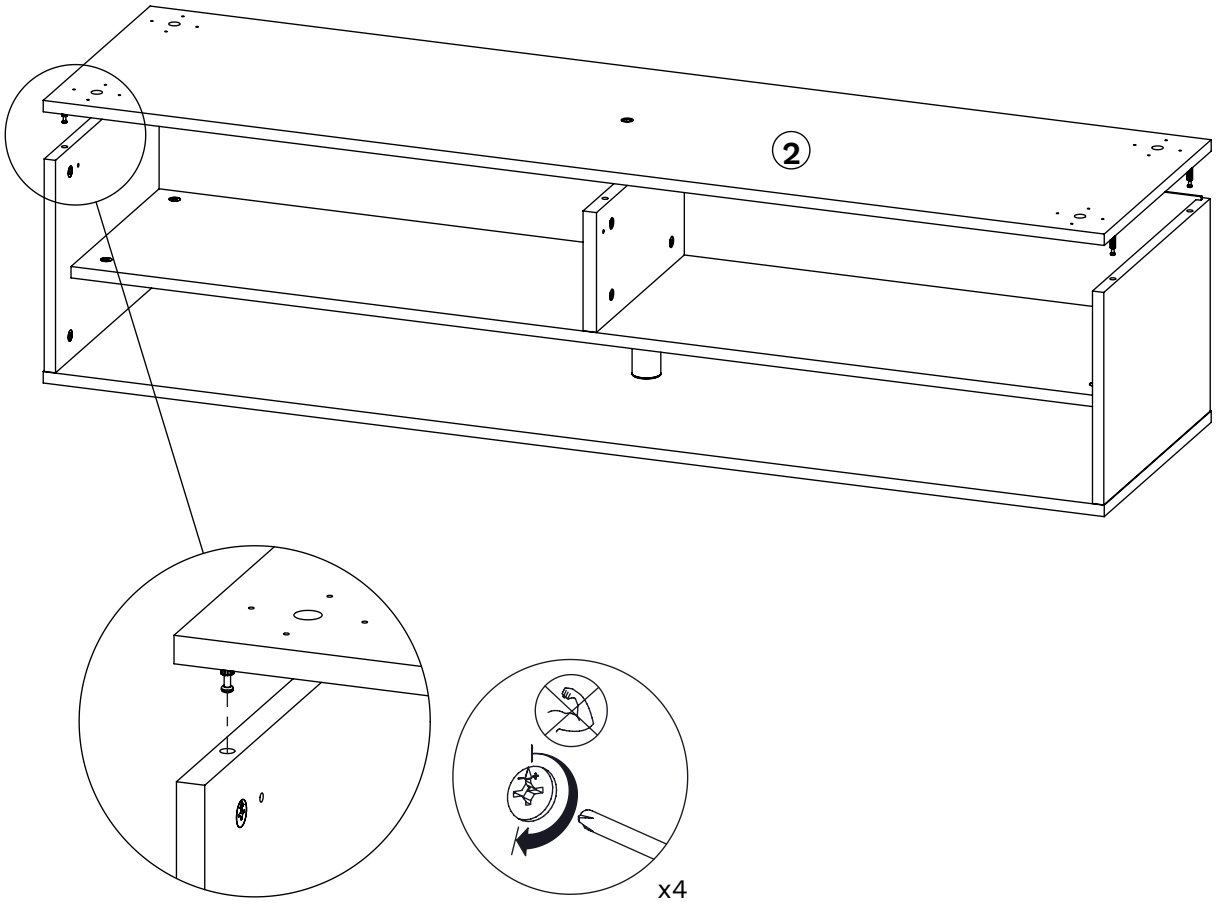

10



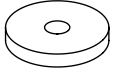

11

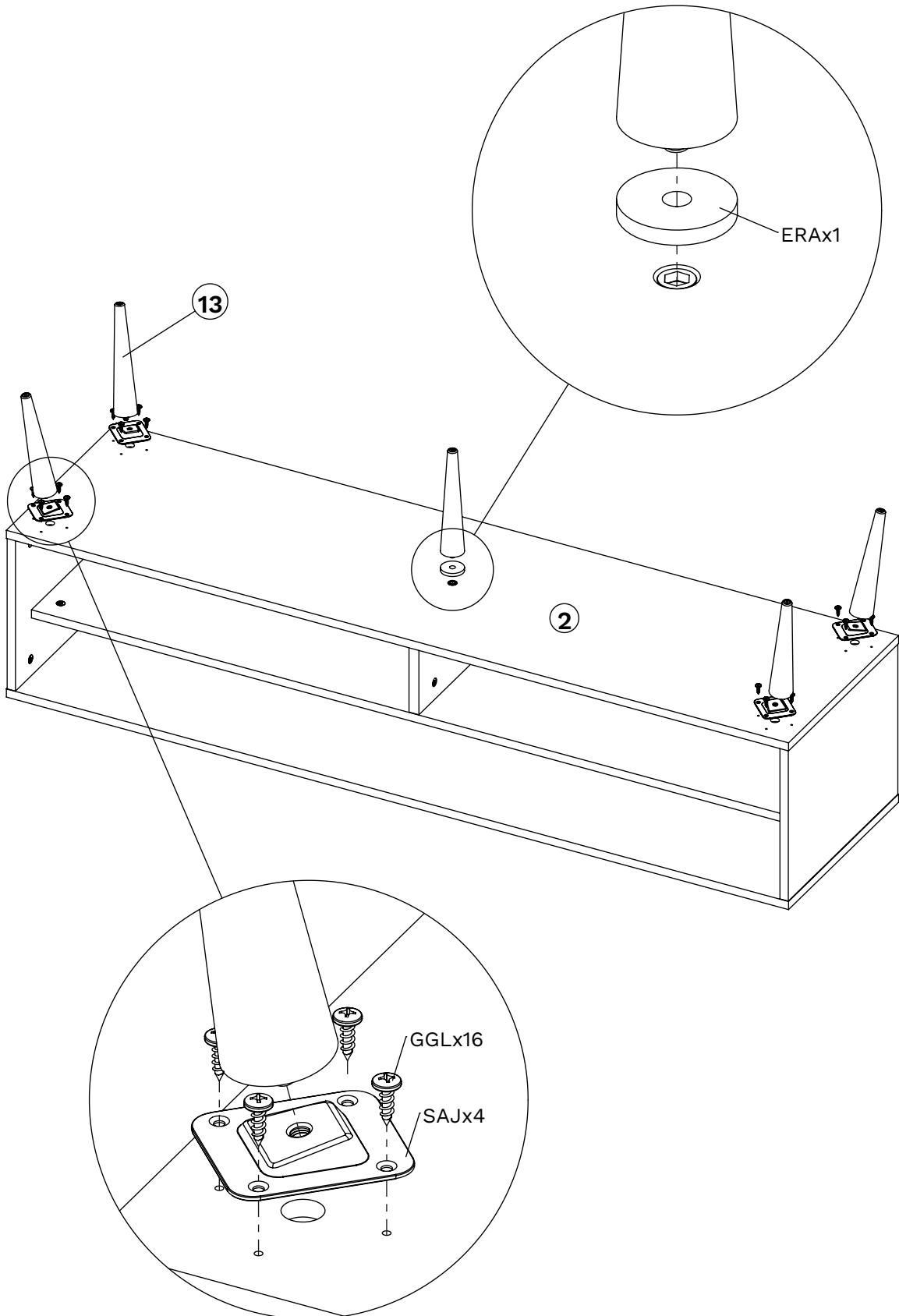
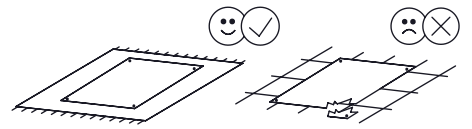
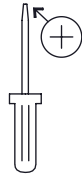
GGL x16	SAJ x4	ERA x1
		
Ø5x16mm		



12

FB x8  Ø6x11mm	OHG x2 	OHH x2 
---	---	---

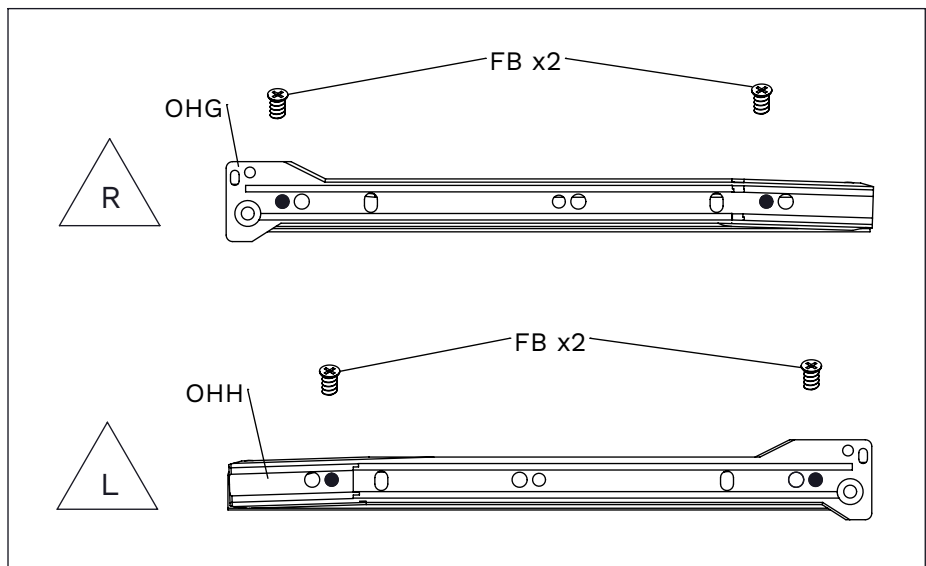
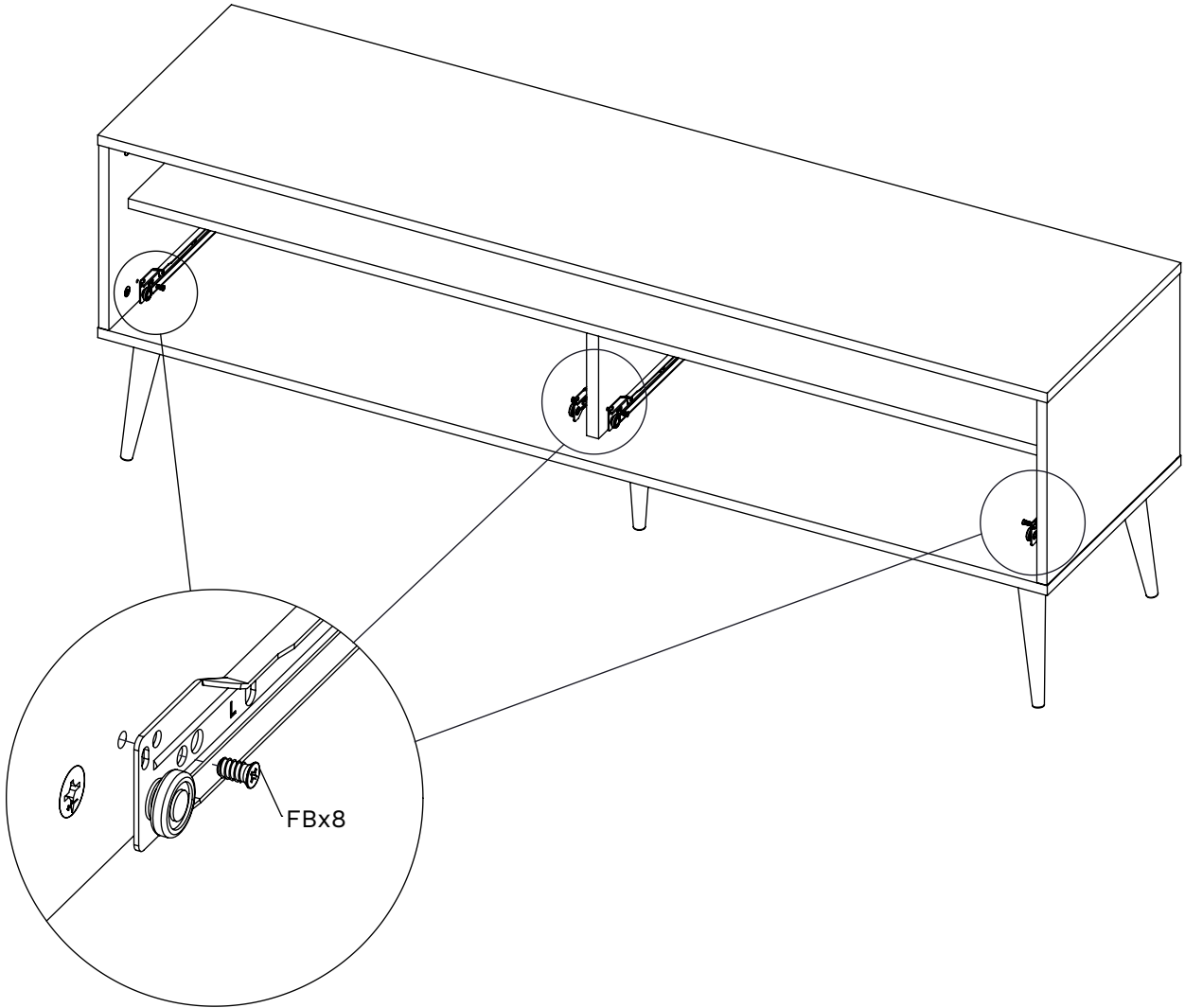
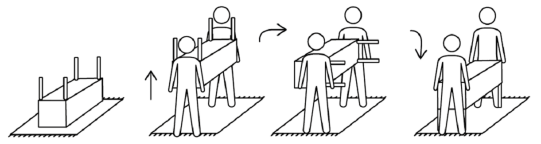
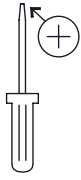

13

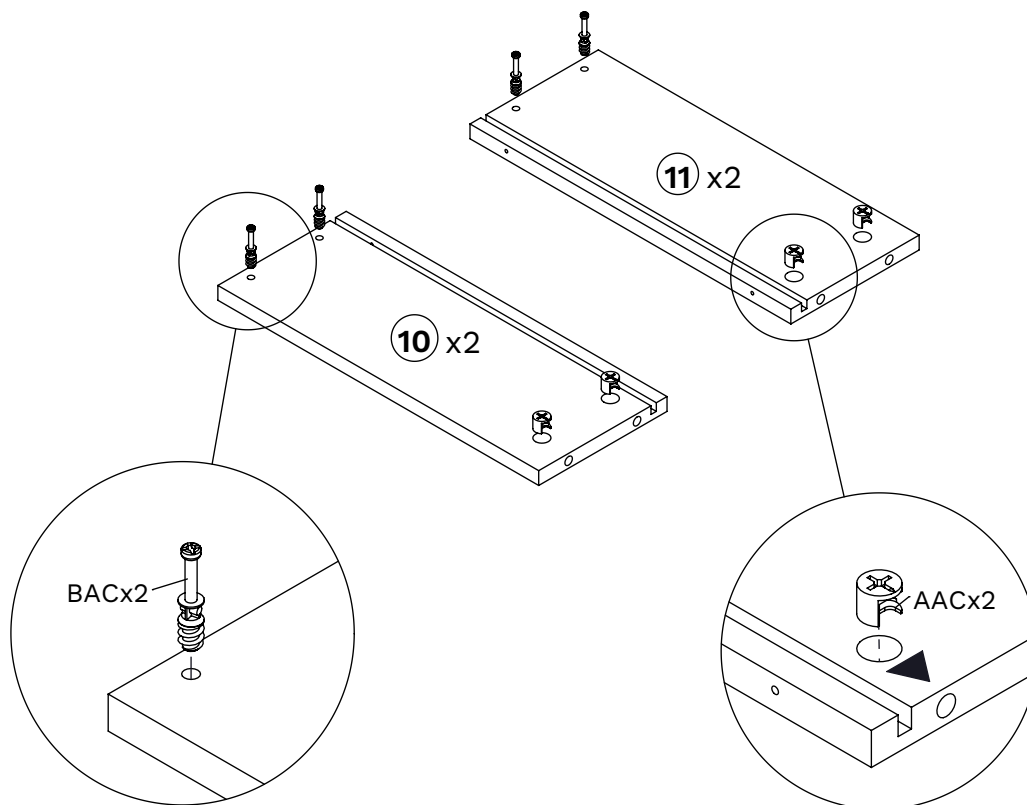
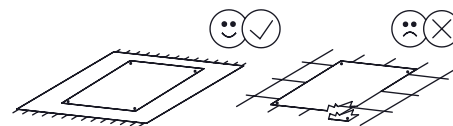
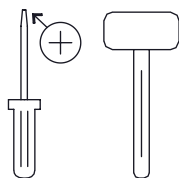
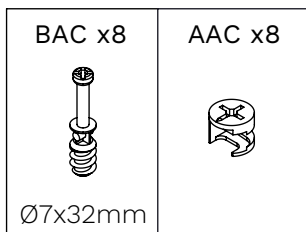

14

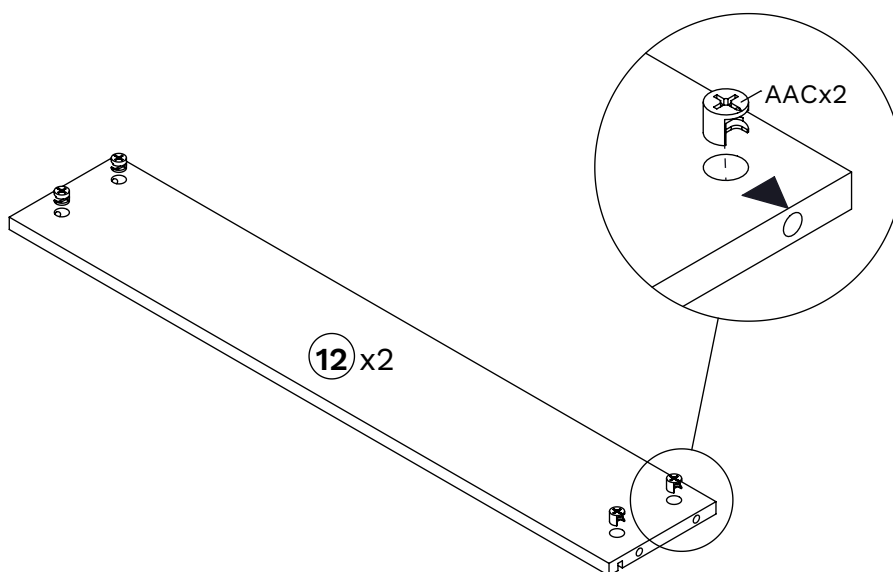
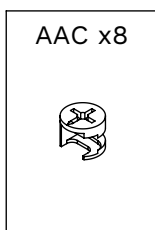

15

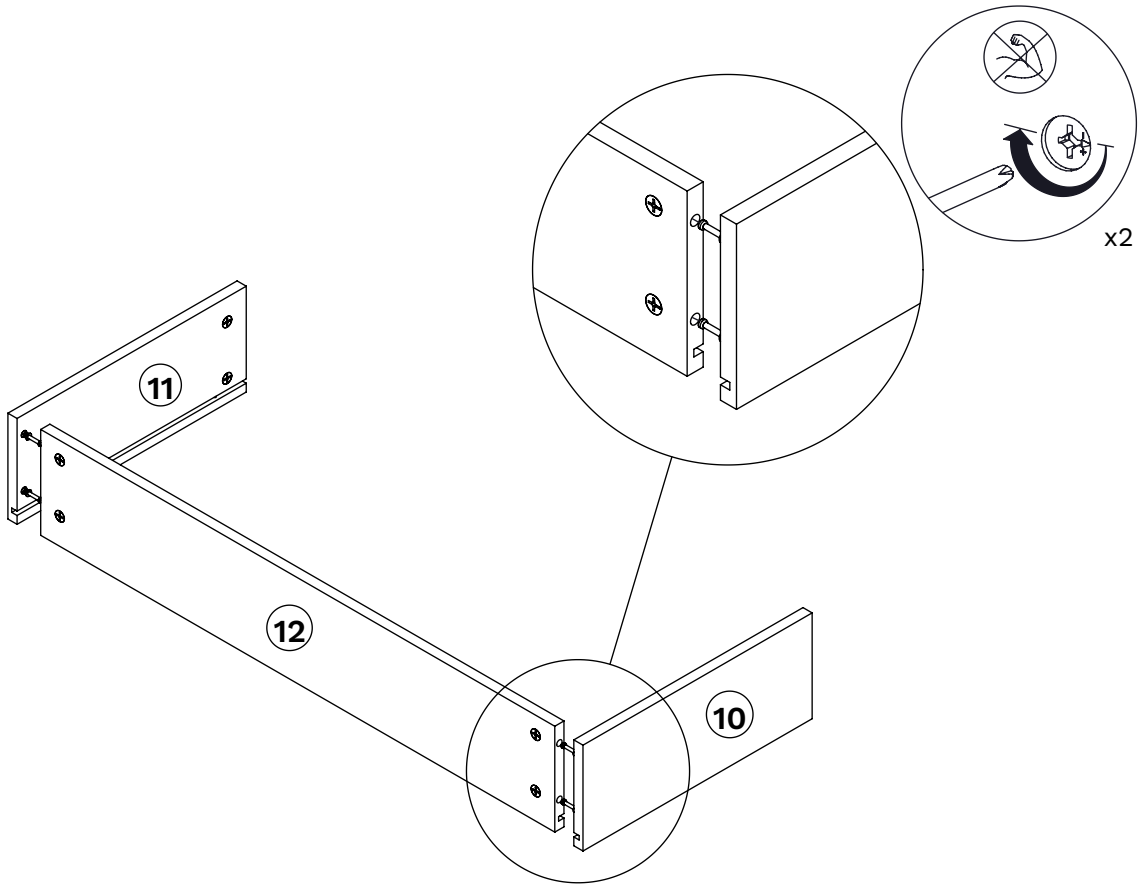
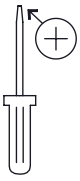

16

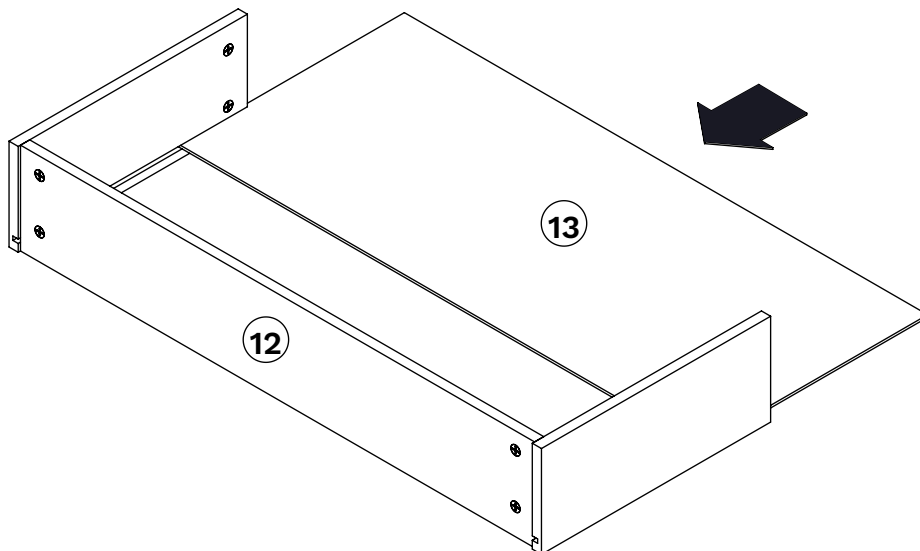

17

BAC x8



Ø7x32mm

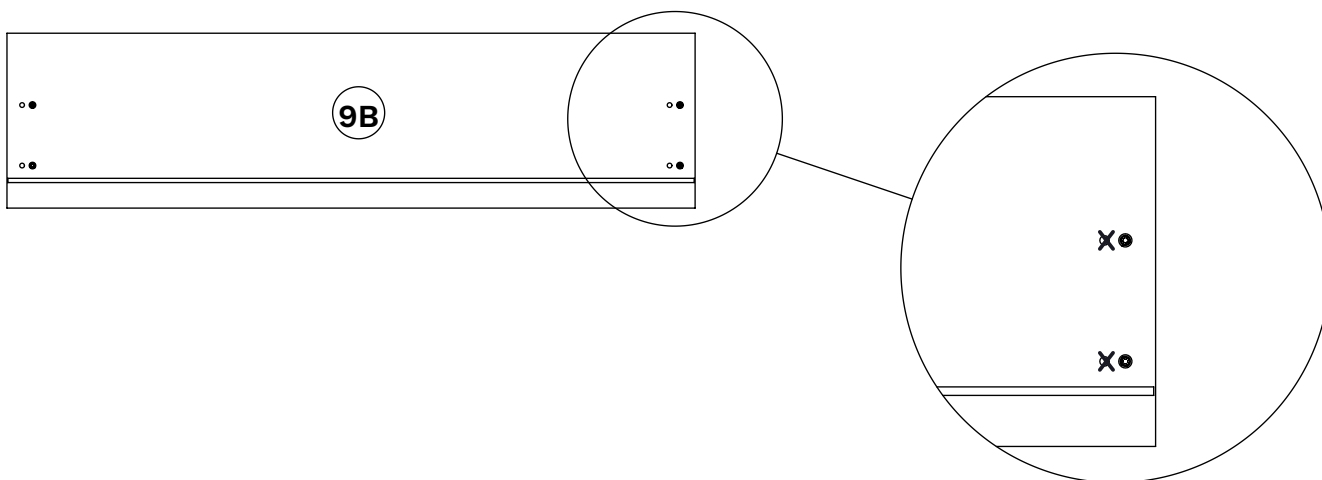
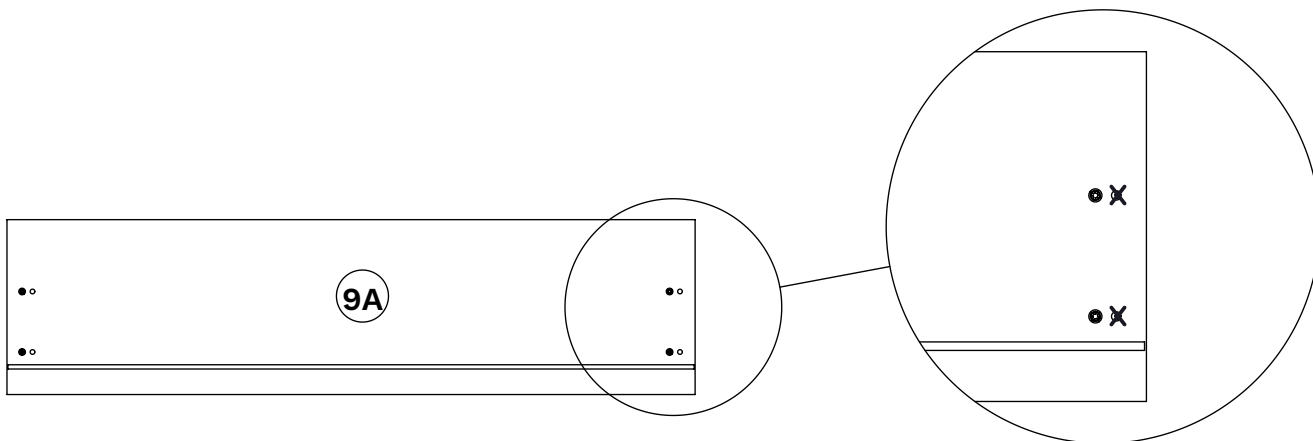
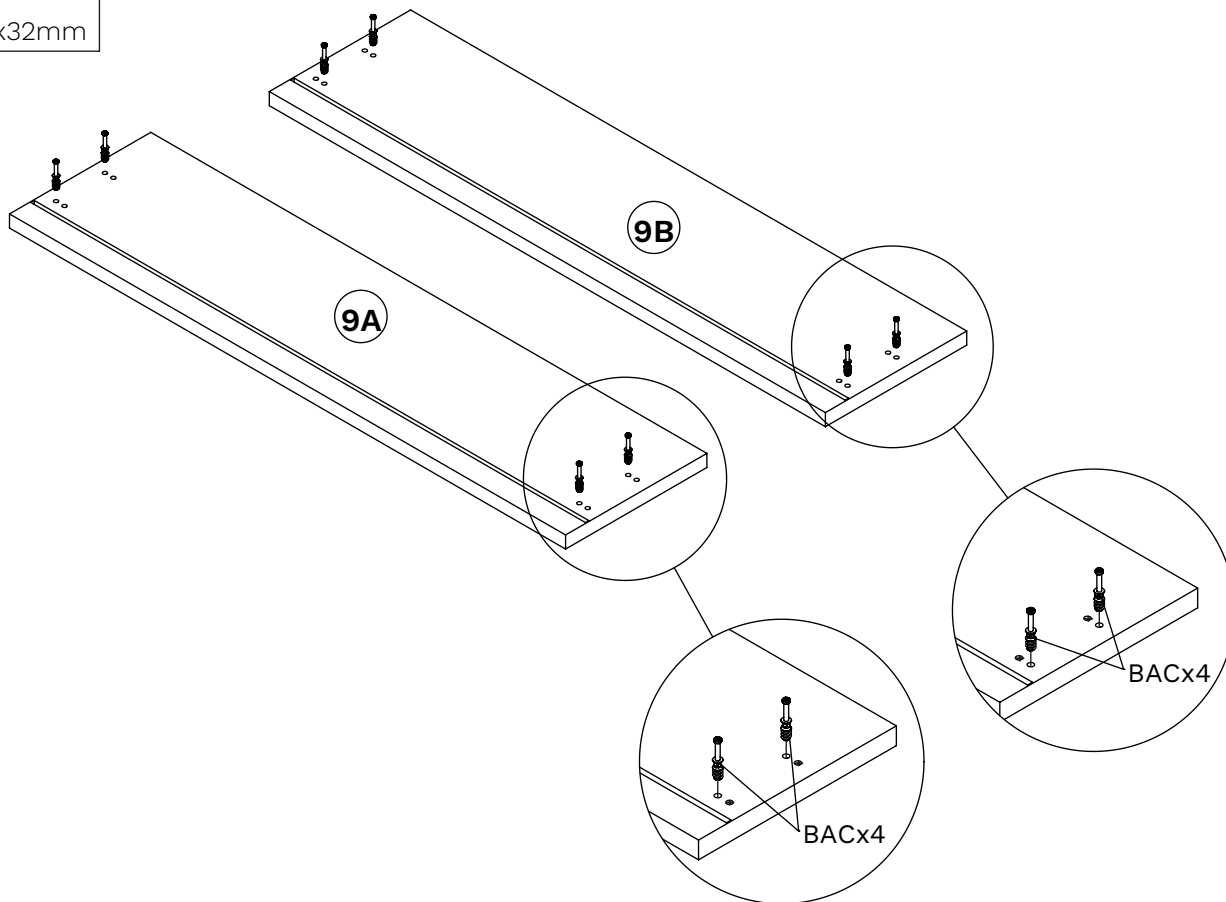
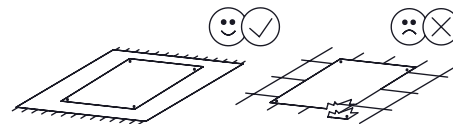

18

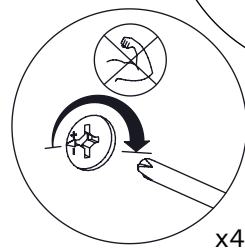
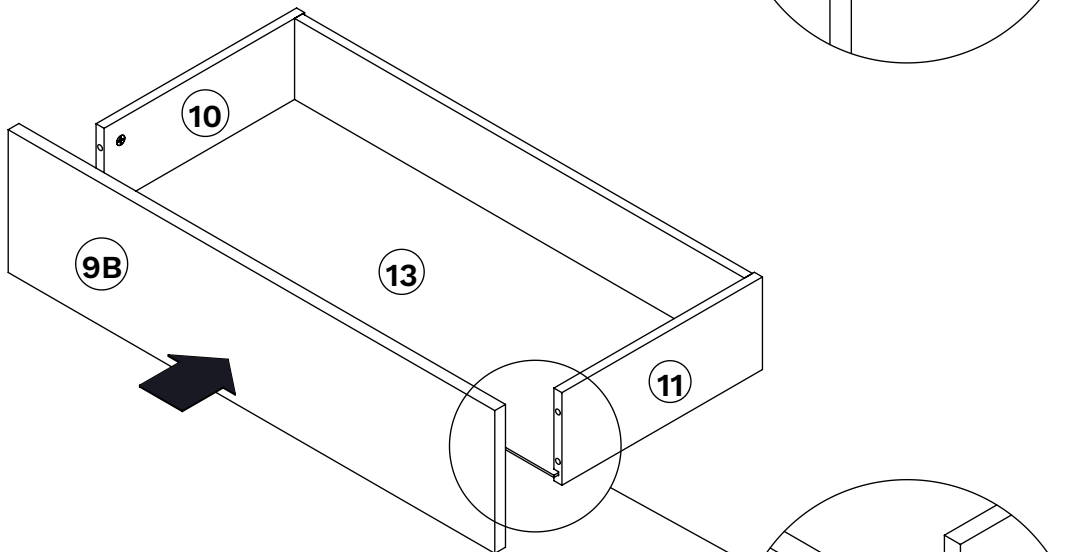
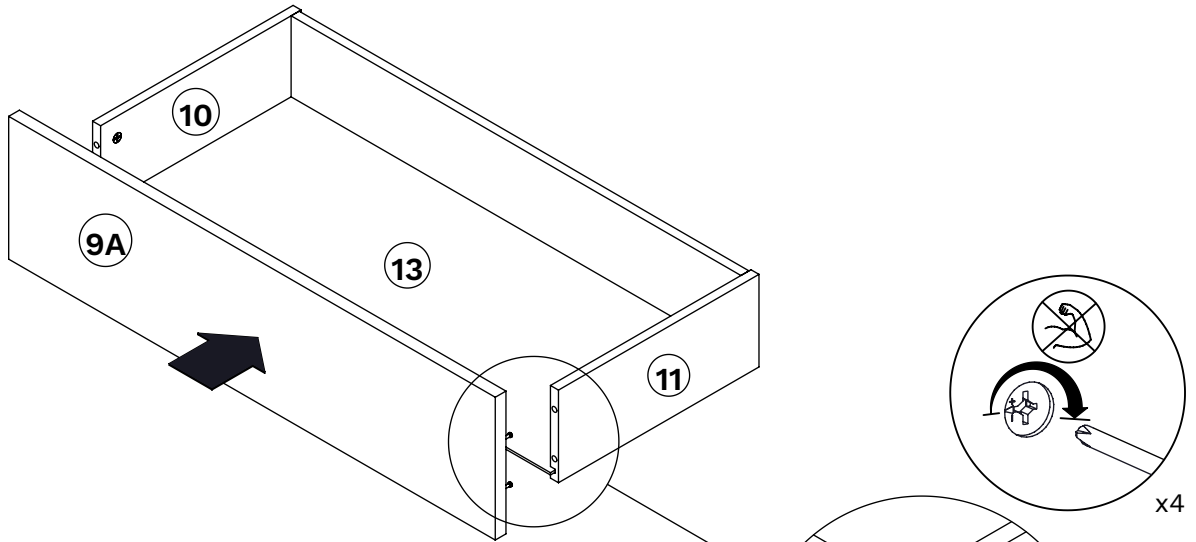
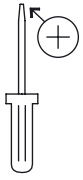

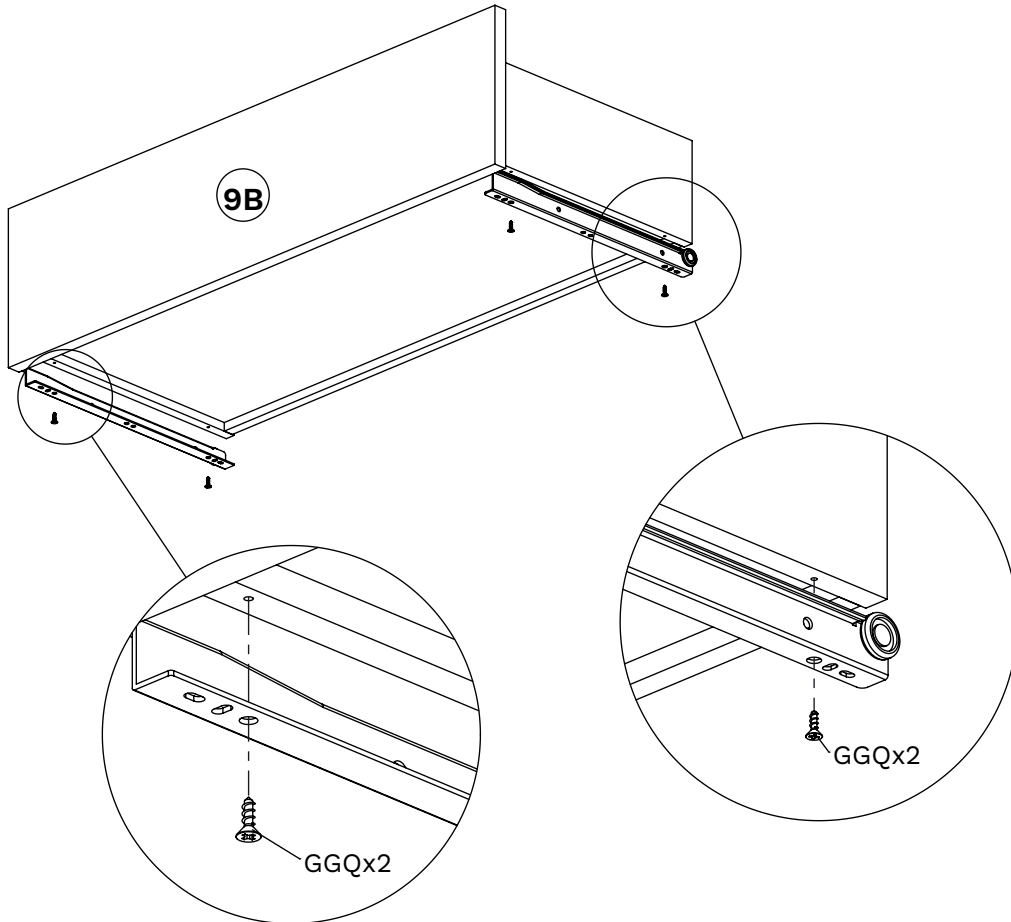
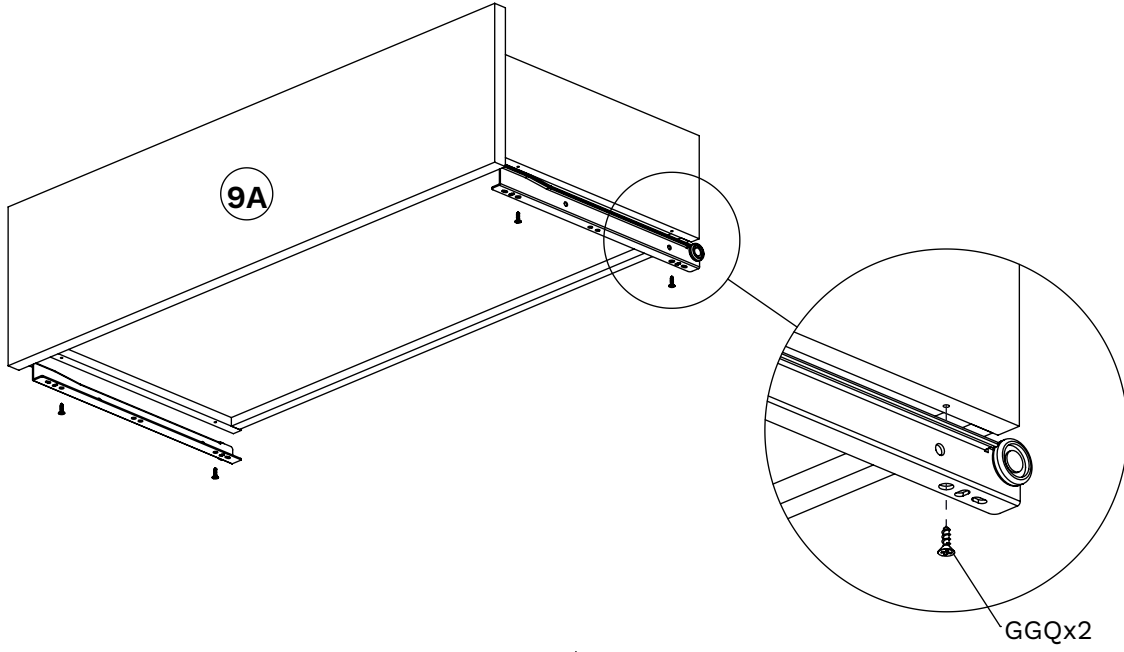
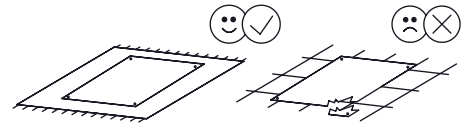
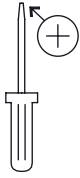

19

GGQ x8
Ø3,5x12mm



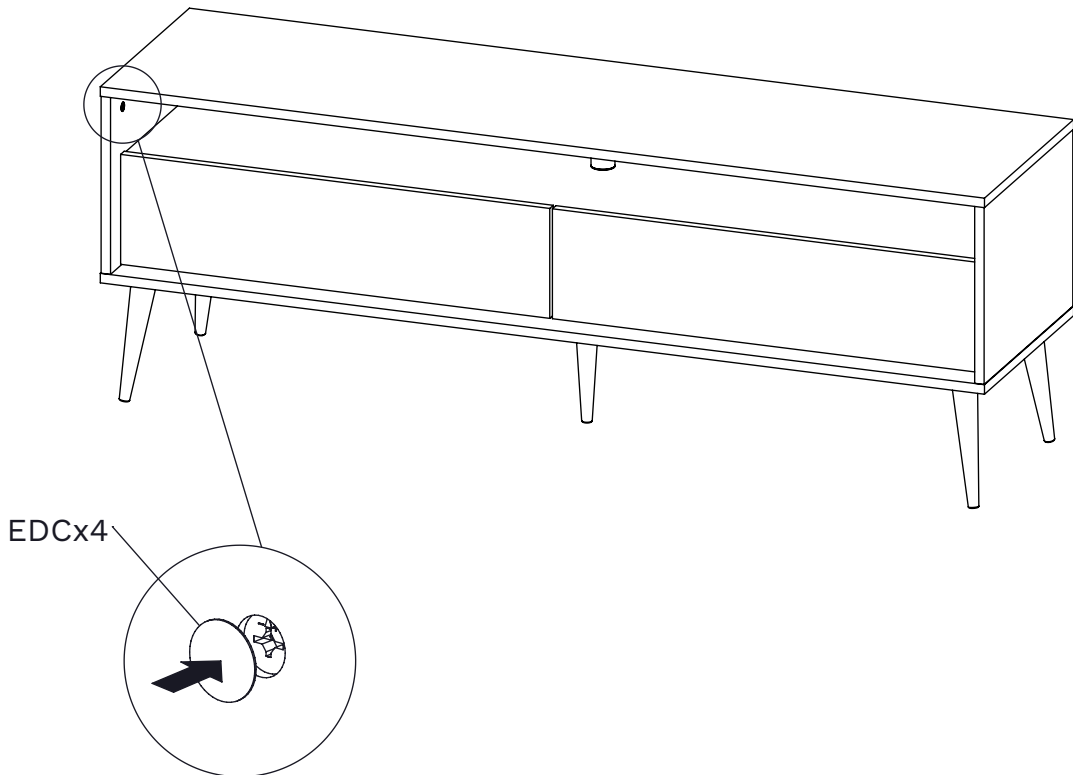
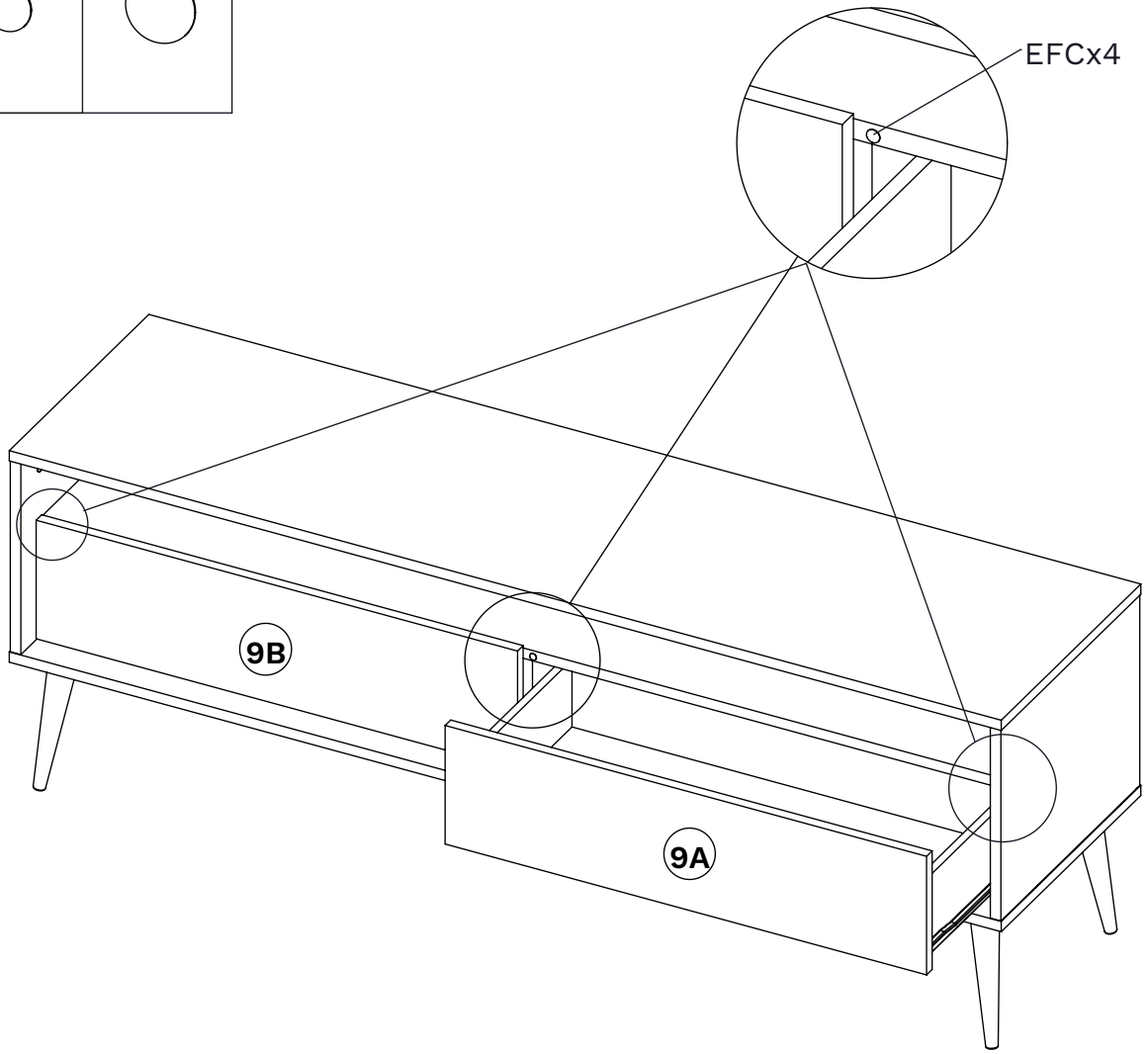

20

EFC x4	EDC x4
	

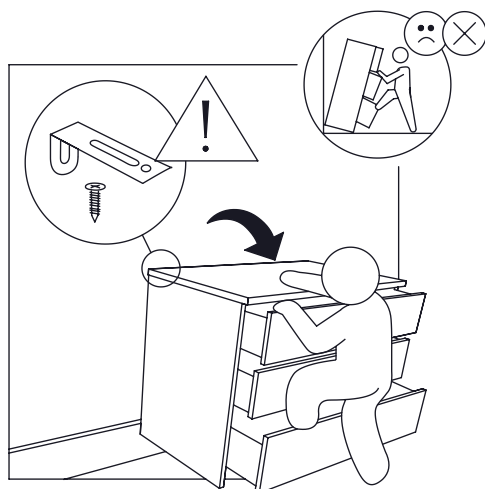
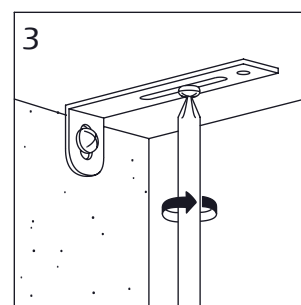
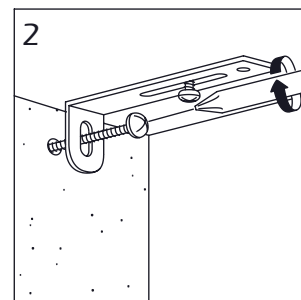
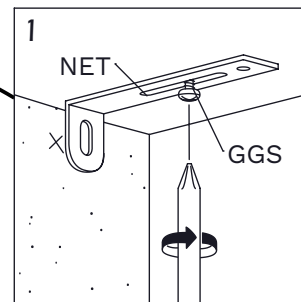
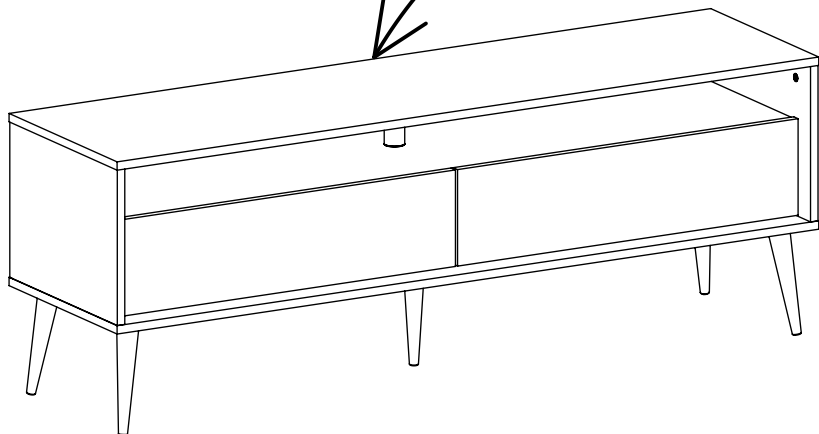
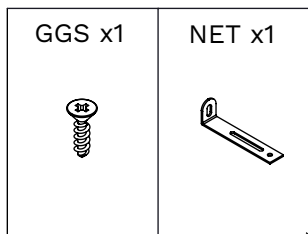

21



 Achtung • Attention • Attenzione • Opgelet • Uwaga • Pozor • Figelem Atenție • Dikkat • Внимание • Atención • Atencão 			
D	Wandbefestigung dient als Kippschutz - unbedingt anbringen! Bei einigen Wandtypen kann ein Spezialdübel erforderlich sein!	CZ	Montáž na stěnu slouží jako ochrana proti převrnutí - bezpodmínečně umístěte! U některých typů stěn může být zapotřebí speciální hmoždinka!
GB	The wall fastening serves to prevent tipping - be absolutely sure to mount it! For certain wall types, a special wall plug may be necessary!	SK	Upevnenie na stenu slúži ako ochrana proti prevráteniu – bezpodmienečne použite! Pre niektoré druhy stien môže byť potrebná špeciálna hmoždinka!
FR	La fixation murale sert de protection contre le basculement - à installer impérativement ! Pour certains types de murs il faut des chevilles spéciales !	HU	A terméket a falhoz kel rögzíténi, különben az felborulhat! Egyes faltípusoknál speciális tiplit kell használni!
IT	Il fissaggio alla parete serve da protezione anti-ribaltamento - attaccarla assolutamente! Per alcune strutture di parete può essere necessario un tassello speciale!	RO	Sistemul de fixare la perete servește ca protecție la rasturnare - de montat obligatoriu! Pentru unele tipuri de pereți este posibil să fie necesar un diblu special!
NL	Bevestiging aan de muur dient als kantelbescherming - zeker en vast bevestigen! Bij enkele muurtypes is een speciale plugmisschien vereist!	TR	Duvardaki sabitleme, devrilmeye karşı bir emniyet tedbiridir ve mutlaka monte edilmelidir! Bazı duvar tiplerinde bunun için özel bir dübel gerekli olabilir!
PL	Mocowanie do ściany jest jednocześnie zabezpieczeniem przed przewróceniem - koniecznie zamontować! Do niektórych rodzajów ścian koniecznie zastosować specjalne kołki mocujące.	PT	A fixação do produto à parede serve para prevenir que este tombe! Certifique-se que executa este passo correctamente. Para determinados tipos de parede pode ser necessário utilizar uma bucha especial!
ES	La fijación a la pared sirve para evitar vuelcos. ¡Asegúrate de montarlo! ¡Para ciertos tipos de pared, se necesitan tacos especiales!	RU	Обязательно установите крепление на стене во избежание опрокидывания! Для некоторых типов стен может потребо- ваться специальный дюбель!

