

# Modell: CITY 36

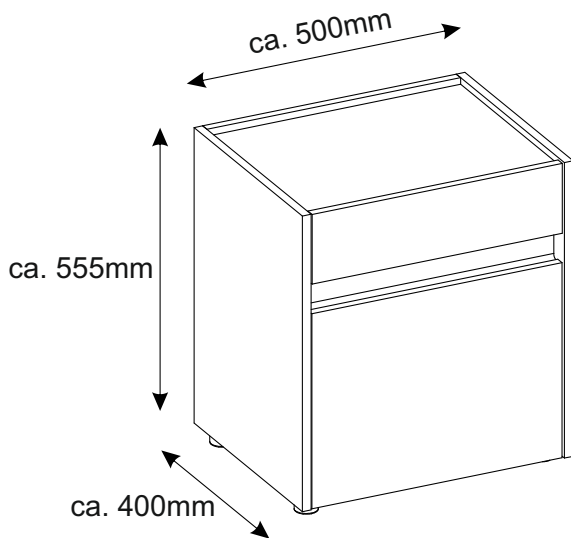

- Ⓛ Montageanleitung
- Ⓝ Handleiding voor de montage
- Ⓜ Montaj talimati
- ⓕ Notice de montage
- Ⓒ Montážní návod
- ⓗ Szerelési útmutató
- ⓖ Assembly instructions
- Ⓟ Instrukcja montażu
- Ⓡ Инструкция по монтажу
- Ⓜ Istruzioni di montaggio
- Ⓚ Návod na montáž
- Ⓡ Instrucțiuni de montaj
- ⓔ Instrucciones de montaje
- Ⓜ Montaj Talimati

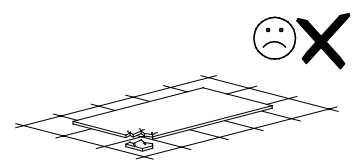

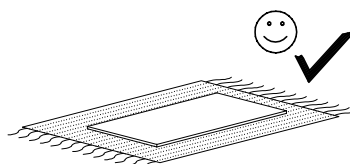
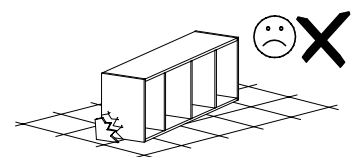
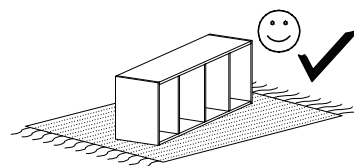
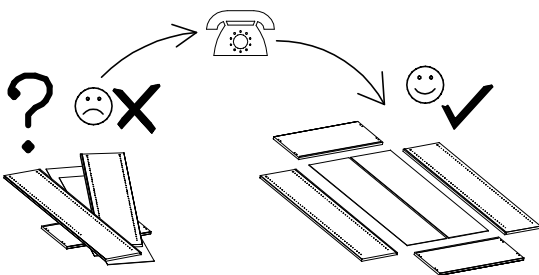
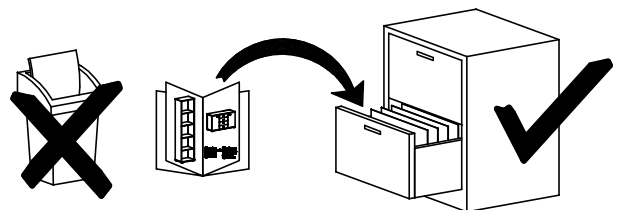
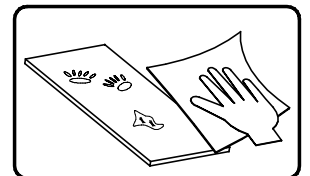
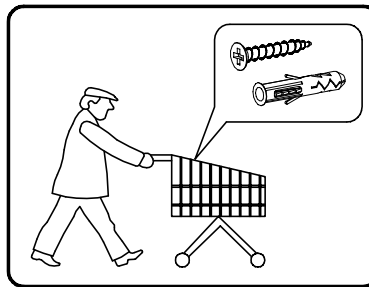
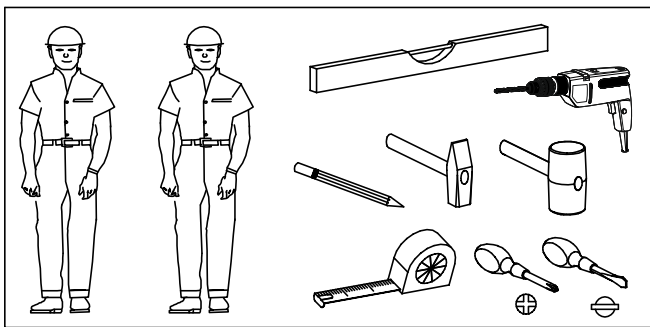
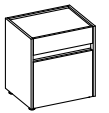



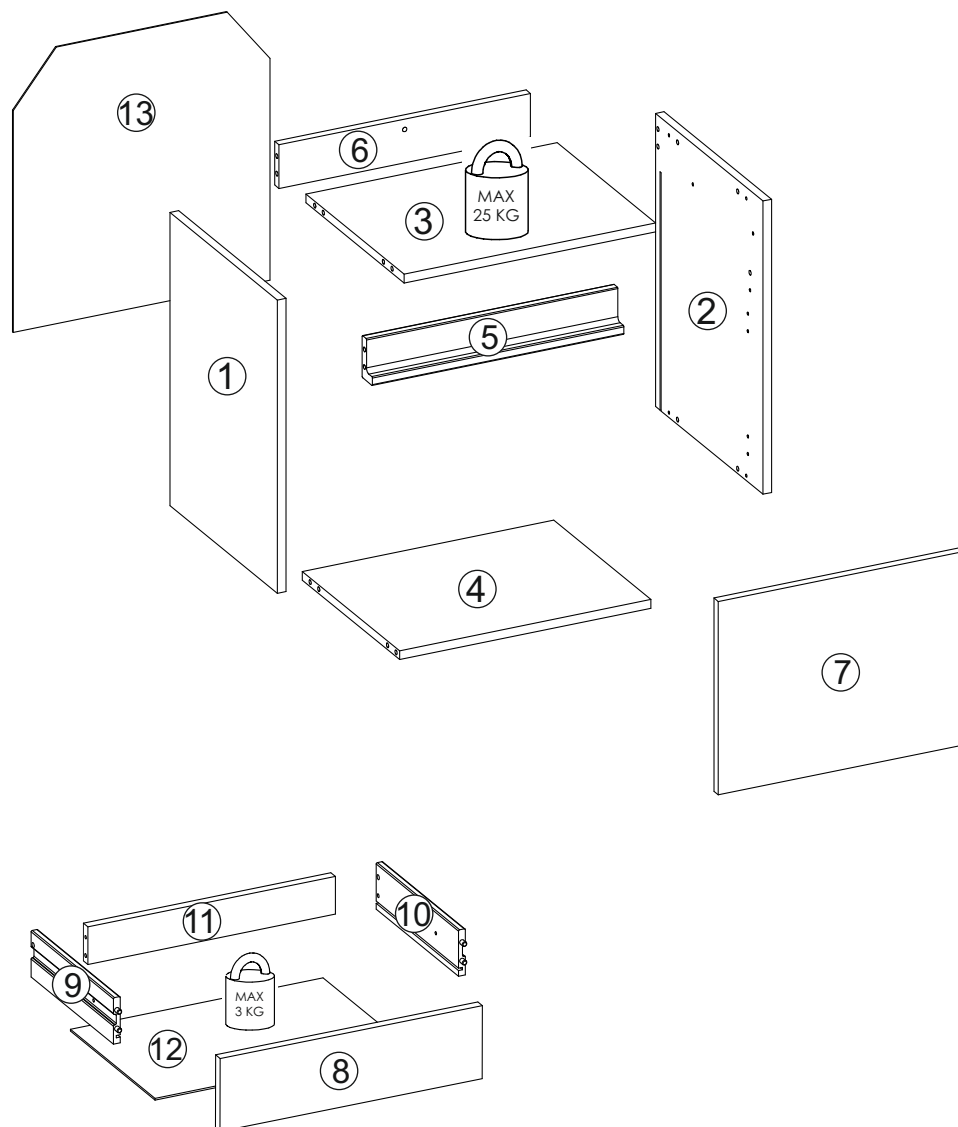

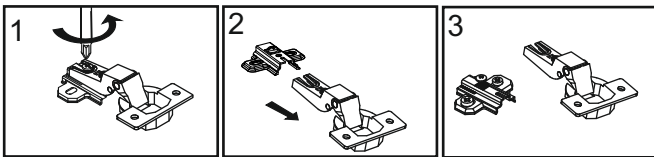
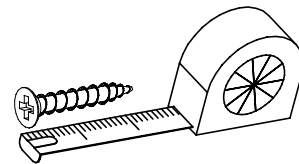
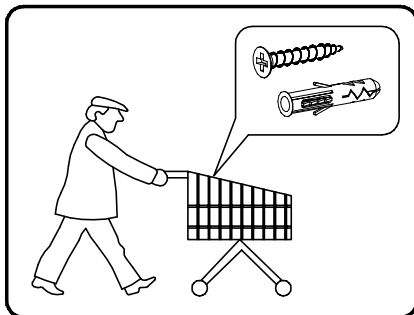
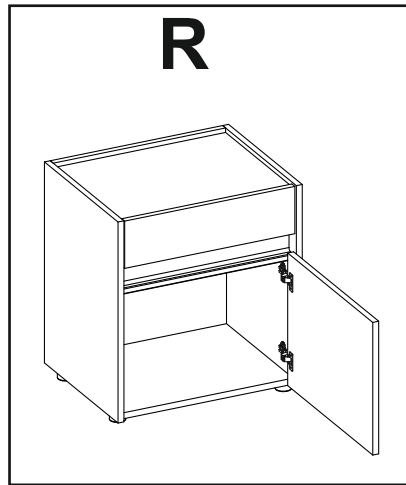
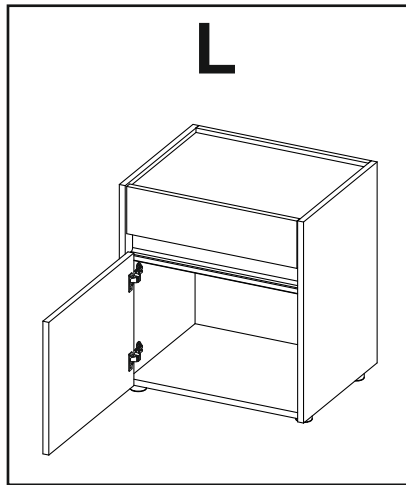
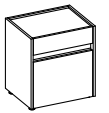



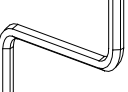

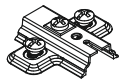
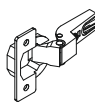

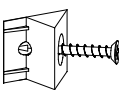
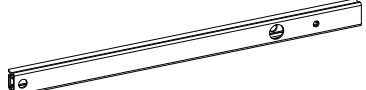

nr	L[mm]	B[mm]	T[mm]	Menge	Colli
1	535	400	16	1	1/1
2	535	400	16	1	1/1
3	468	366	16	1	1/1
4	468	362	16	1	1/1
5	468	77	38	1	1/1
6	468	80	16	1	1/1
7	462	353	16	1	1/1
8	462	126	16	1	1/1
9	290	80	12	1	1/1
10	290	80	12	1	1/1
11	436	65	12	1	1/1
12	446	297	3	1	1/1
13	505	478	3	1	1/1

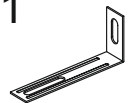



<b>B1</b>  ø8x35 x14	<b>B2</b>  ø6x30 x2	<b>A1</b>  ø7x50 x3	<b>W2</b>  x1	<b>K1</b>  x10
<b>K10</b>  x10	<b>D4</b>  x2	<b>C6</b>  x2	<b>G34</b>  3,5x16 x5	<b>G47</b>  6,3x13 x4
<b>G49</b>  4x16 x3	<b>N1</b>  M4x9 x2	<b>I1</b>  x4	<b>H5</b>  x2	
<b>W1</b>  x1	<b>M11</b>  x1	<b>G50</b>  3x20 x8	<b>P10</b>  x4	<b>G36</b>  4x30 x4

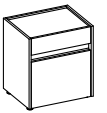

K10



x10

H5



x2

G47



6,3x13

x4

B1



ø8x35

x4

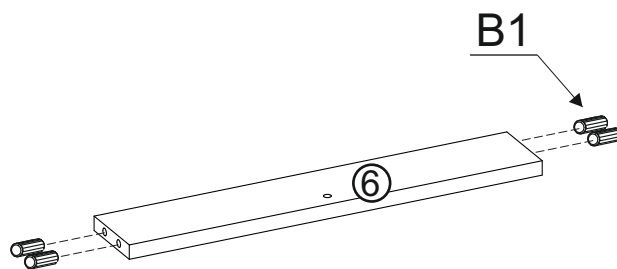
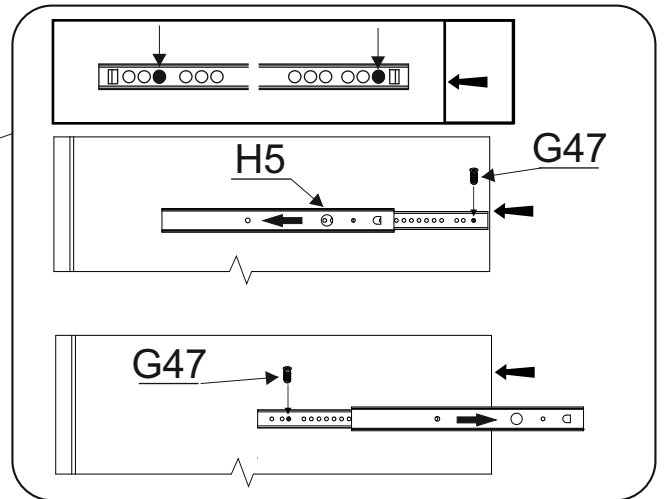
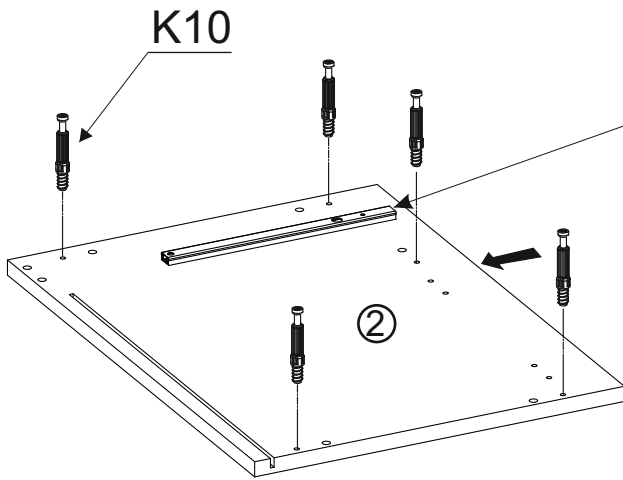
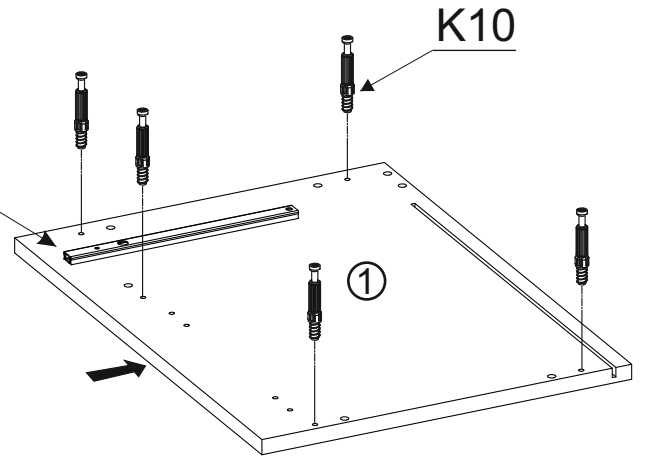
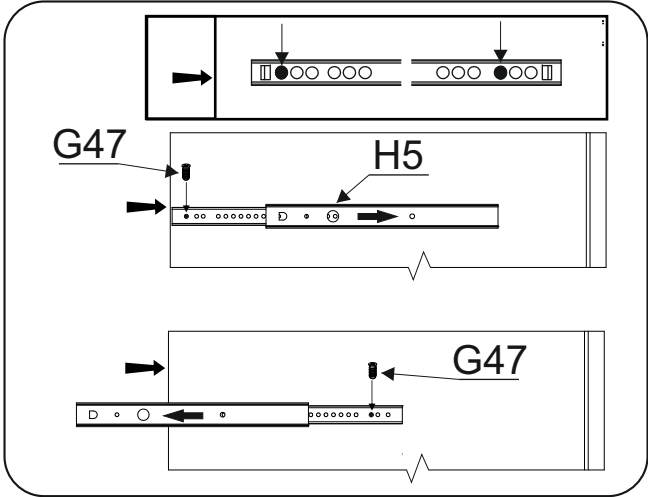
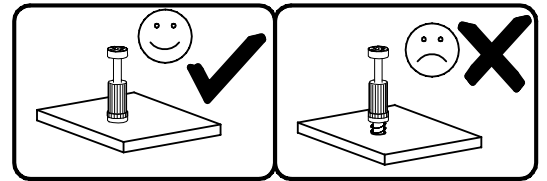

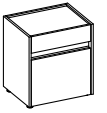

II

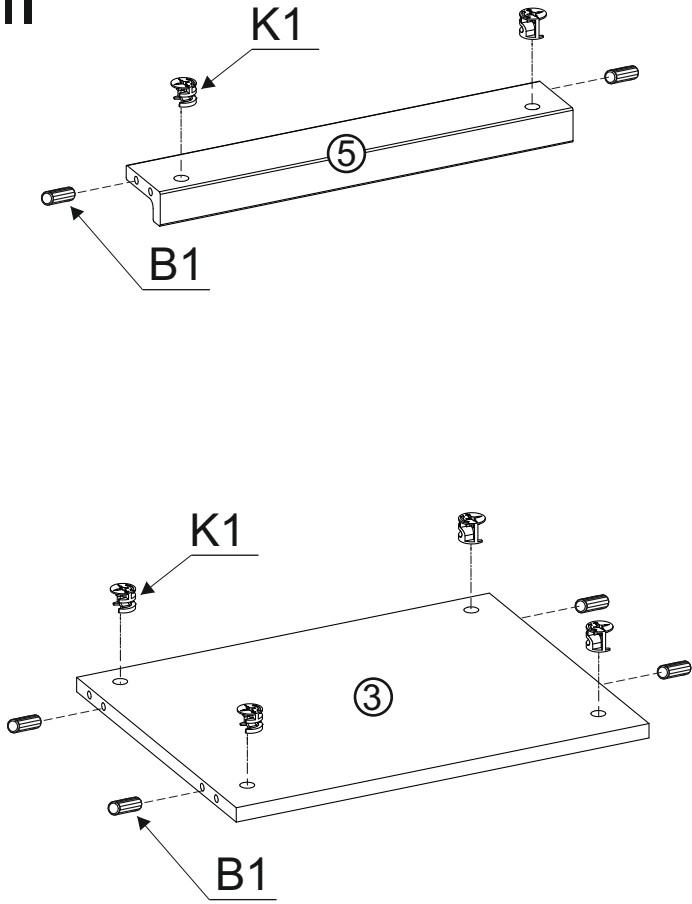

K1



x10

B1



ø8x35

x10

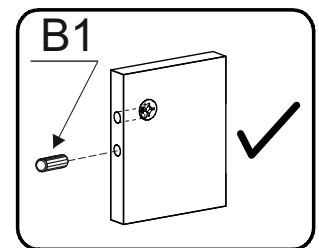
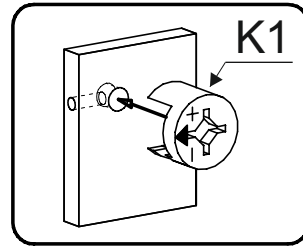

III

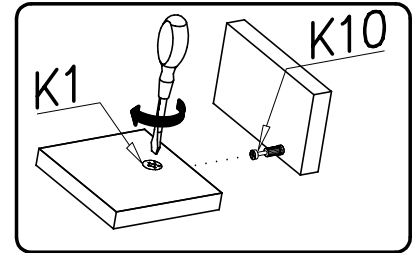
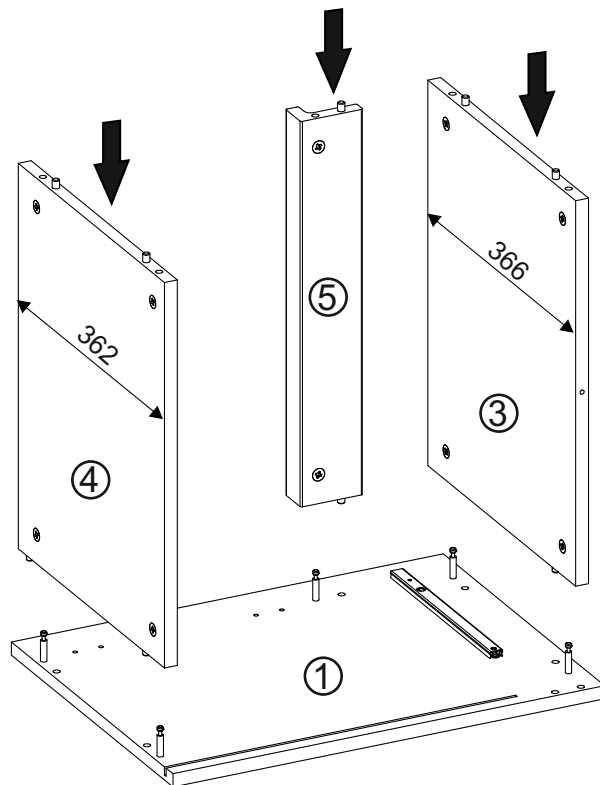

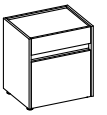

IV

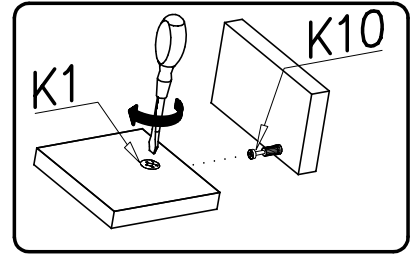
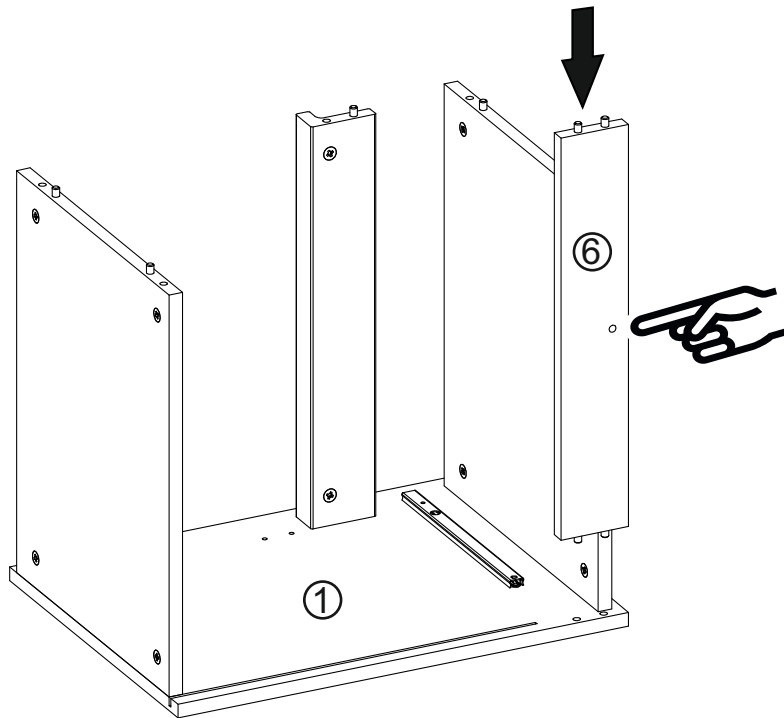

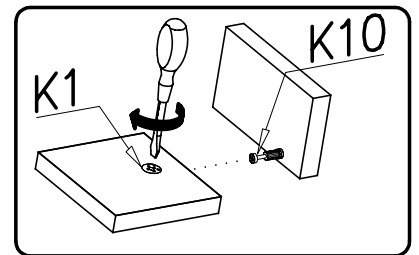
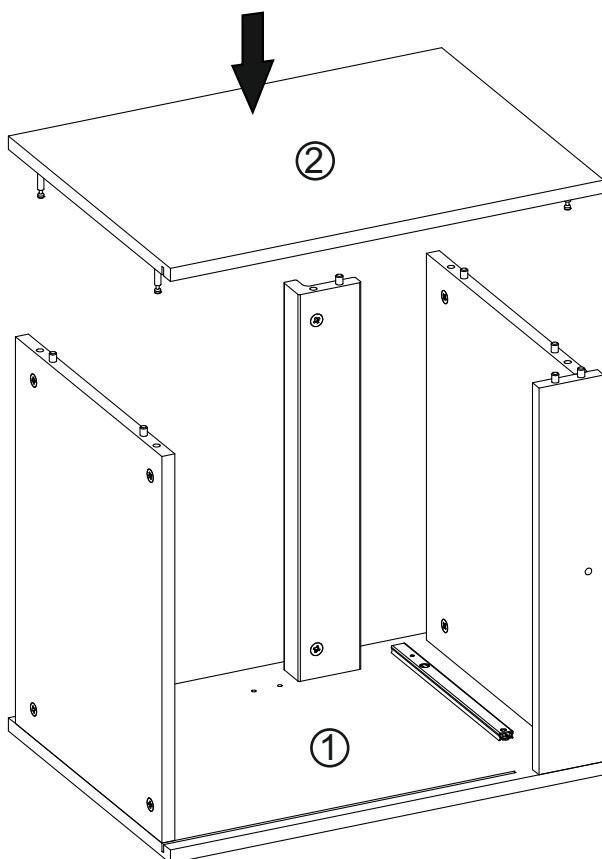

V

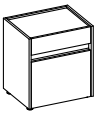

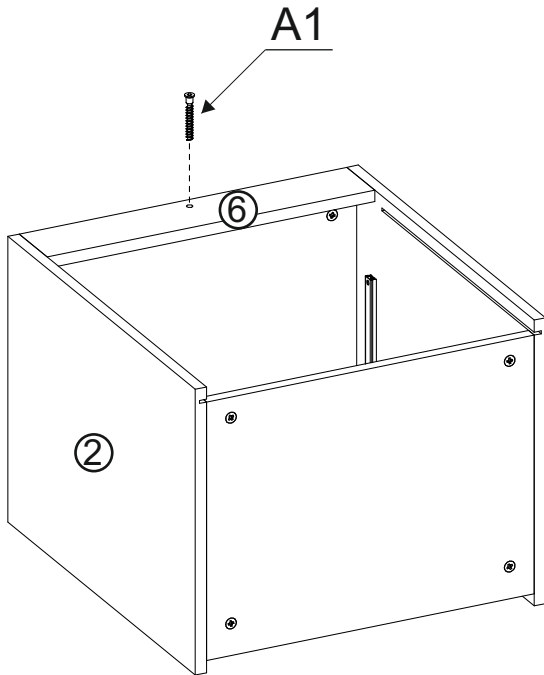

VI

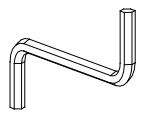

**A1**  
  
 ø7x50 x1

**W2**  
  
 x1

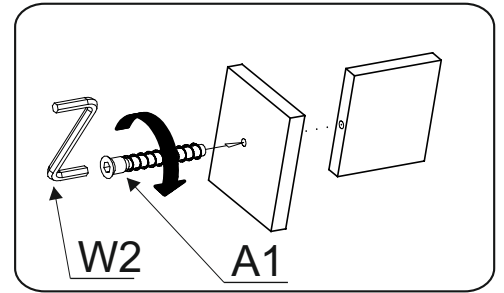

VII

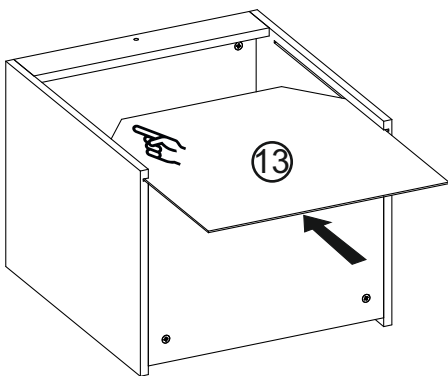

A=B

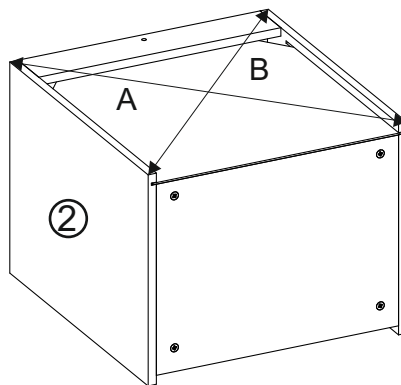

**G50**  
  
 3x20 x4

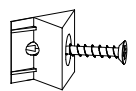
**I1**  
  
 x4

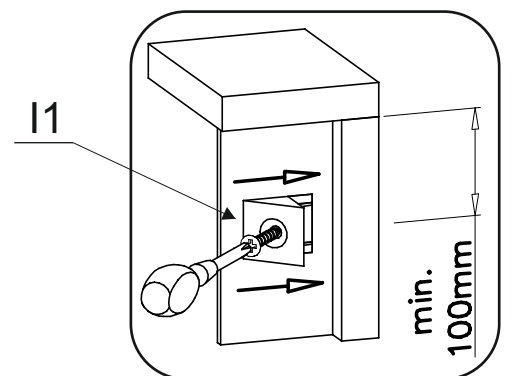
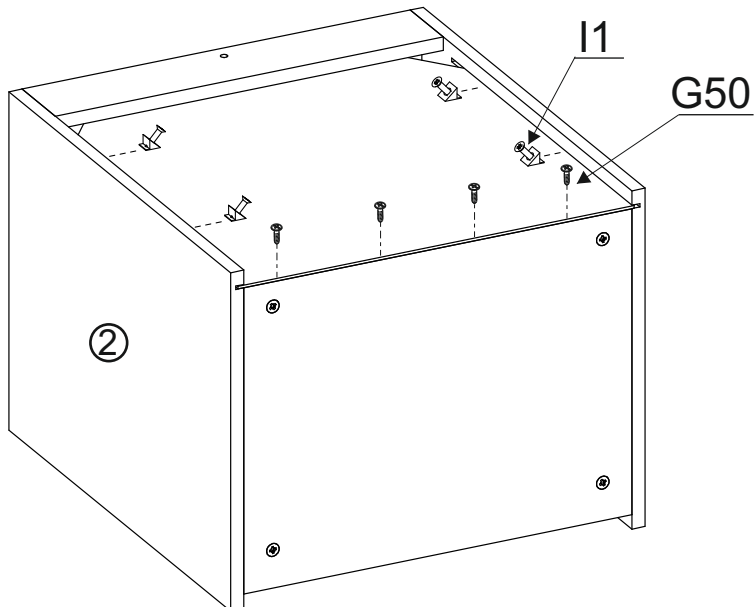
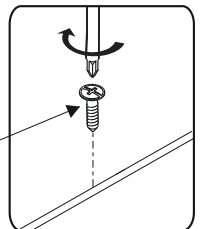
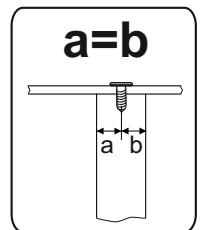

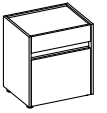

VIII

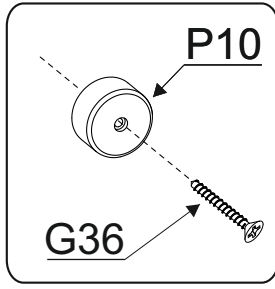

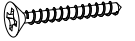
P10		x4
G36		x4
4x30		

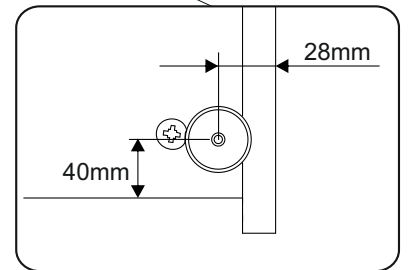
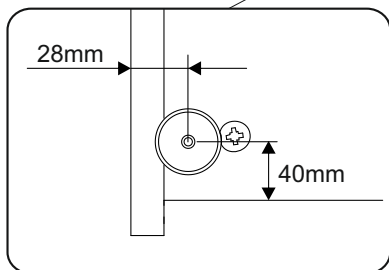
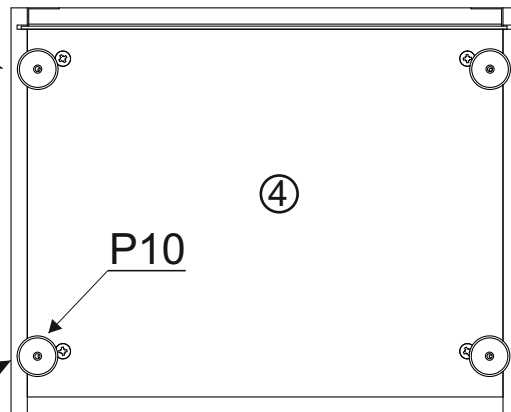
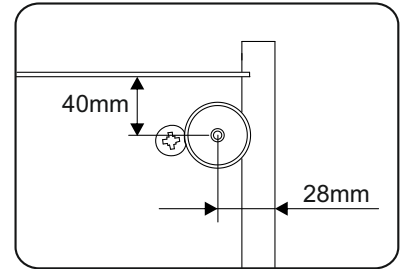
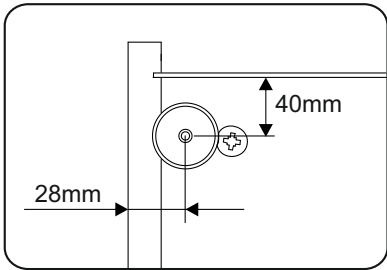
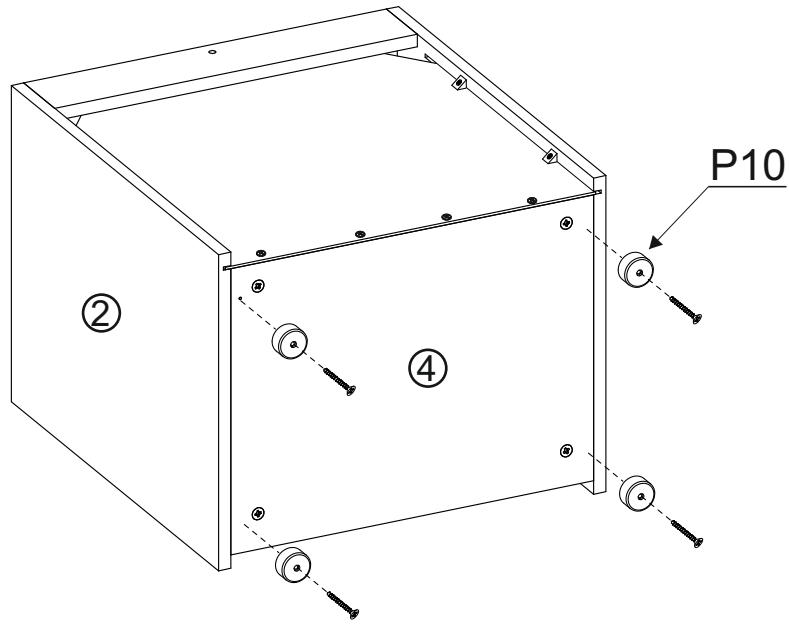



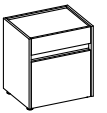

# IX

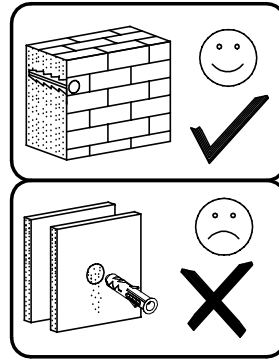
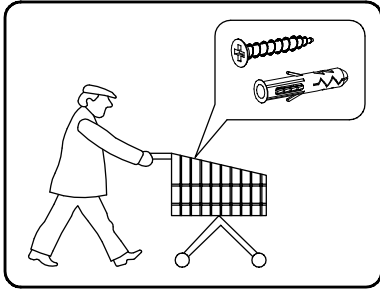

G34



3,5x16

x1

M11

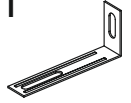

x1

G49



4x16

x3

M11

M11

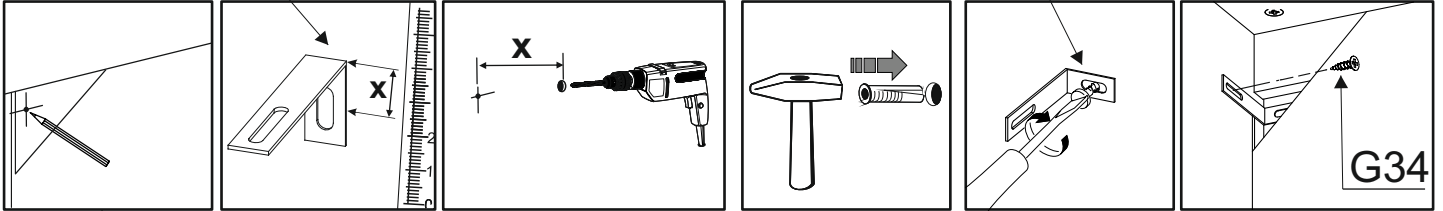

G49

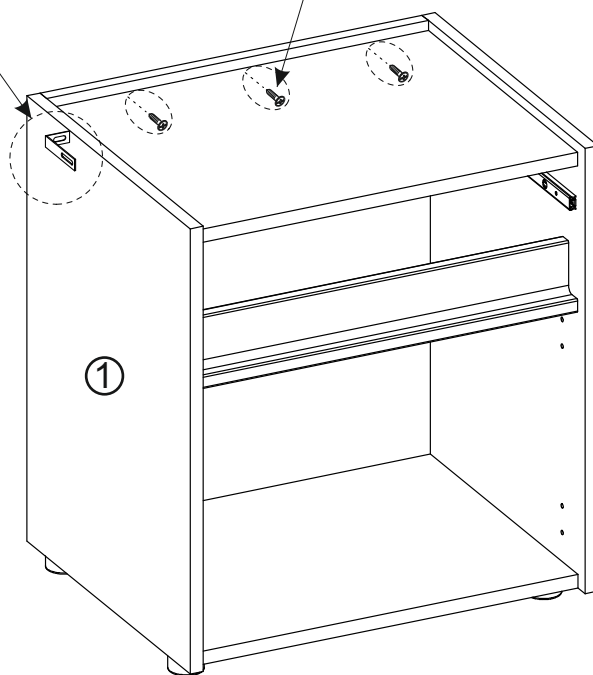

G49

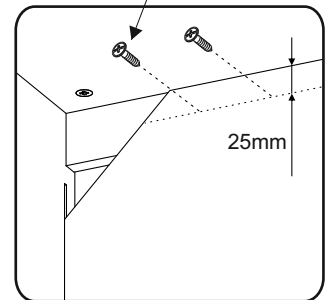

25mm

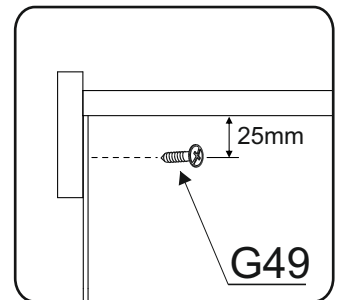

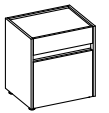

25mm

G49



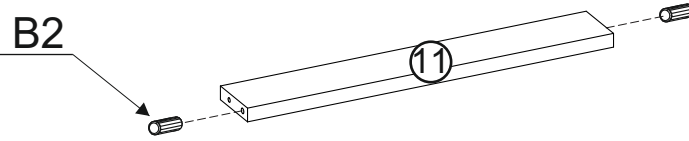

X

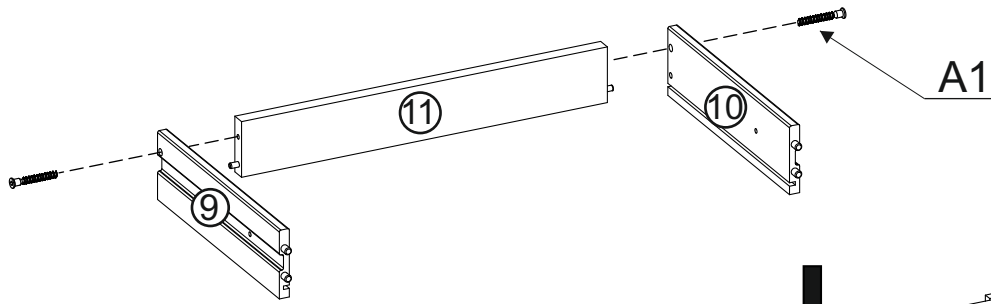

**B2** 

∅6x30 x2



**A1** 

∅7x50 x2

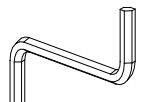
**W2** 

x1

**W1** 

Glue x1

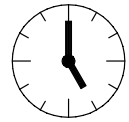
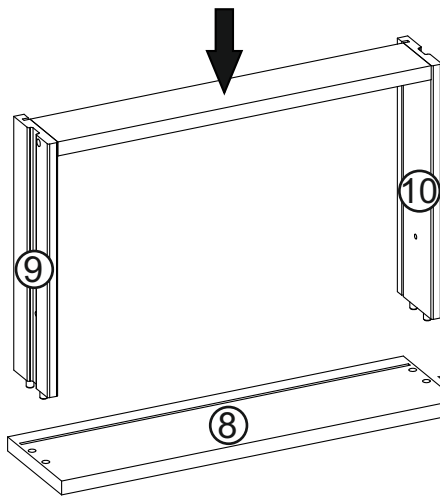

0,5h

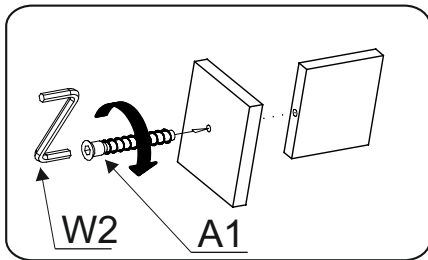
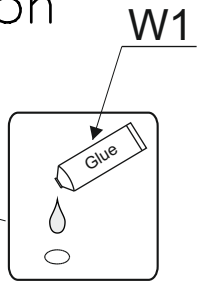

XI

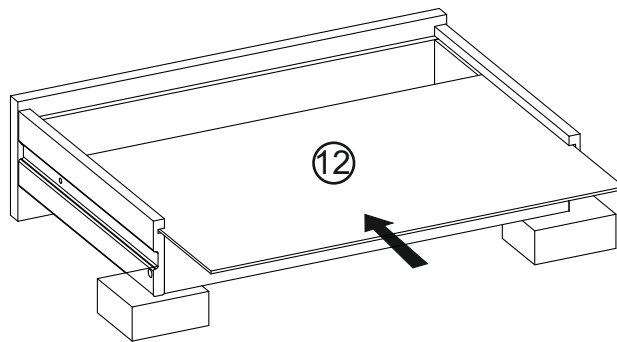

**G50** 

3x20 x4

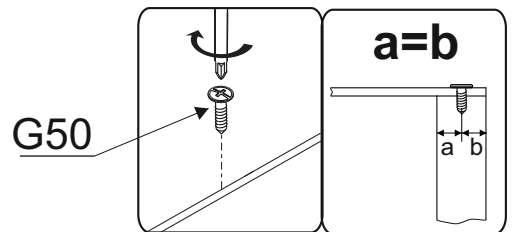
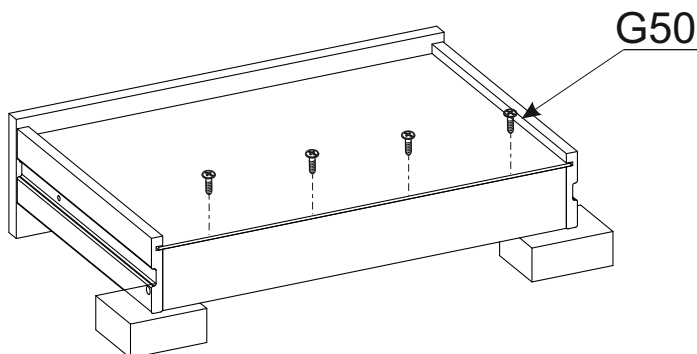

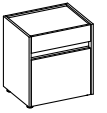

# XII

N1

M4X9



x2

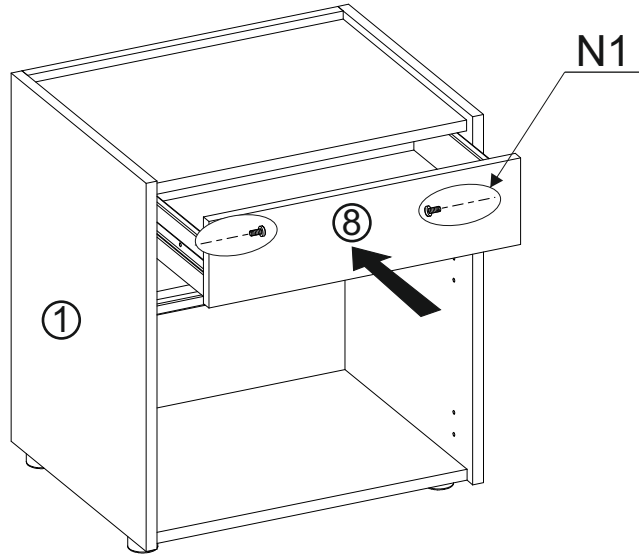
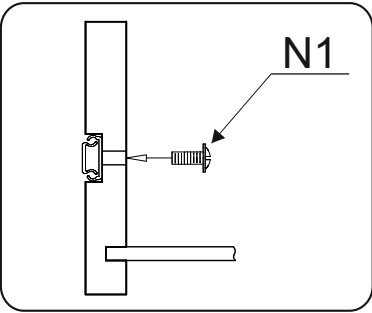
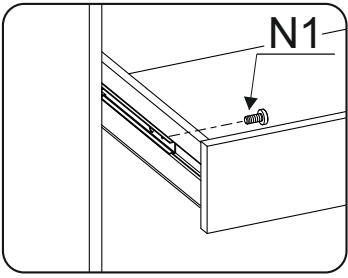
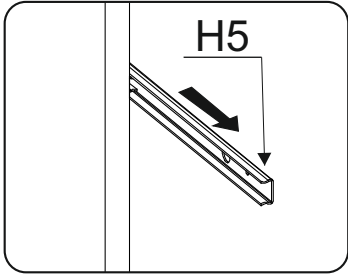

# XIII

L

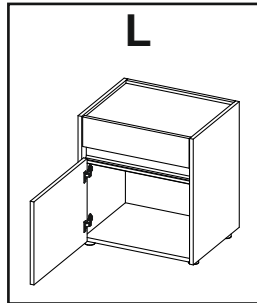

R

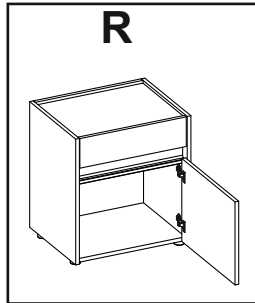

D4

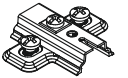

x2

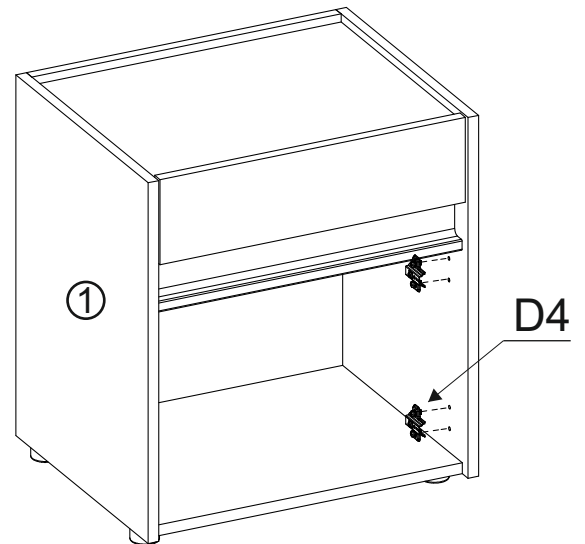
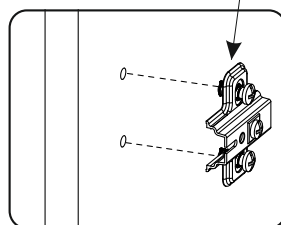
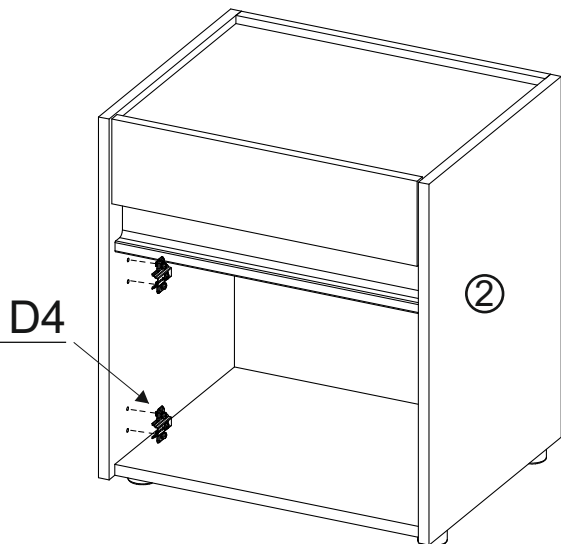

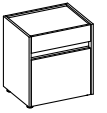

# XIV

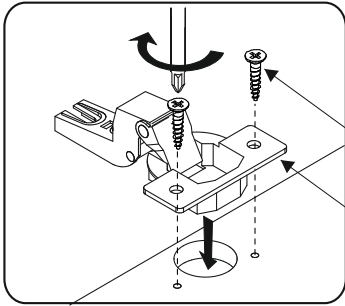

G34

C6

C6

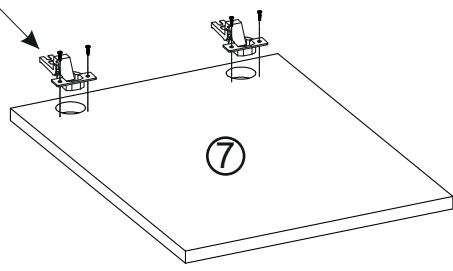

⑦

C6

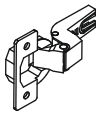

x2

G34



3,5x16

x4

# XV

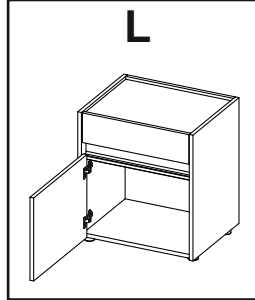

L

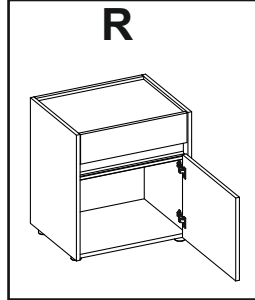

R

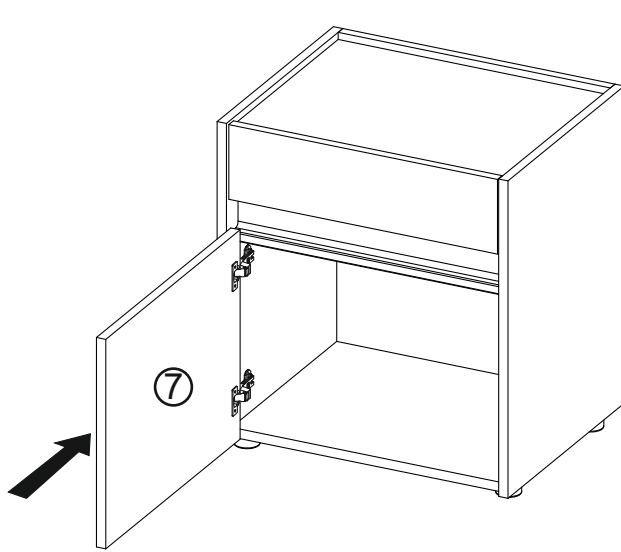

⑦

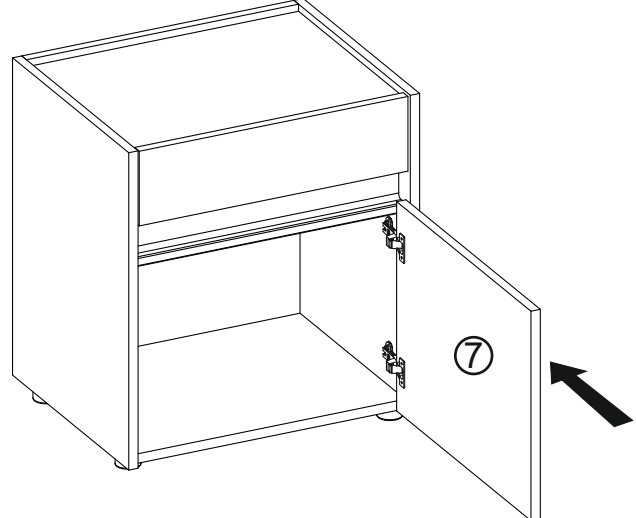

⑦

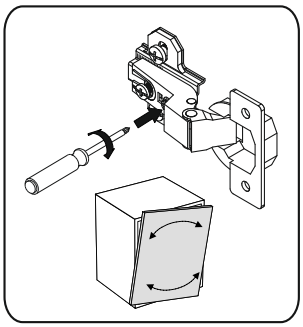
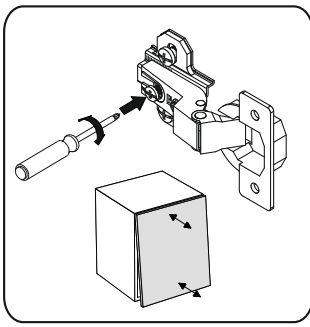
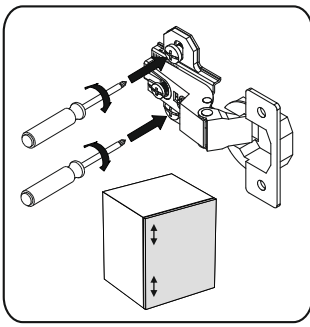
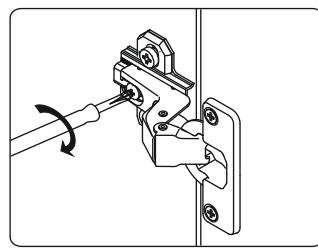
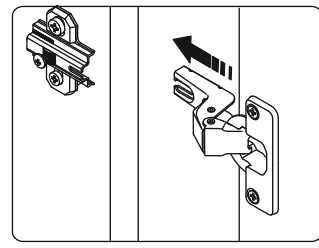

Name • Nom • Nome • Naam • Nazwa • Imięno • Názov • Név • Denumire • Isim • Имяние  
 CITY 36 — — 53

**Unser Direktservice für Beschlagteile**

Sollte Ihnen ein Beschlagteil fehlen, können Sie diese Servicekarte direkt an die untenstehende Adresse mailen. Wir können allerdings nur Beschlagteile auf diesem Wege verschicken. Sollten Sie eine andere Beanstandung an Ihrem Möbelstück haben, so wenden Sie sich bitte direkt an Ihr Möbelhaus.

**Our direct order service for fitting**

If a fitting part is missing, you can e-mail this service card directly to the address below. However, we can only send fitting parts in this way. If you have any other cause for complaint concerning your item of furniture, please contact your furniture store directly.

**Naše přímé služby pro kování**

Chybí-li vám nějaký díl z kování, můžete tuto servisní kartu odeslat e-mailem přímo na níže uvedenou adresu. Touto cestou však můžeme zoslat jen díly kování. Pokud byste reklamovali jiný díl nábytku, obraťte se přímo na svého prodejce nábytku.

**Bien etudier la notice de montage**

S'il vous manque une ferrure, veuillez envoyer directement la présente carte service à l'adresse e-mail indiquée ci-dessous. Cependant, ceci nous permet uniquement d'envoyer des ferrures. Pour tout autre type de réclamation concernant votre meuble, veuillez contacter directement votre magasin d'ameublement.

**Il nostro servizio diretto per l'ordine della ferramenta**

Qualora Vi dovesse mancare un pezzo di fissaggio, allora Vi preghiamo di inviare questa carta di servizio immediatamente all'indirizzo sottostante. Possiamo inviare i pezzi di fissaggio solamente per mezzo di questo procedimento. Qualora dovete avere qualche altra reclamazione in merito al mobile, allora Vi preghiamo di rivolgerVi direttamente al Vostro Negozio di mobili.

**Нашата директна услуга за обков**

Ако липсват части от комплекта, попълнете настоящата сервисна карта и ни я изпратете на e-mail адреса, посочен по-долу. По този начин можем да доставяме само липсващи елементи от обкова. Ако установите други дефекти по мебелите, Ви съветваме да се обърнете към мебелната къща/магазин, от който сте закупили стоката.

**Onze directservice voor losse onderdelen**

Wanneer er een onderdeel ontbreekt, kunt u deze servicekaart direct aan onderstaand e-mailadres sturen. Wij kunnen langs deze weg echter alleen beslagdelen versturen. Mocht u een ander probleem aan uw meubel hebben, verzoeken wij u contact op te nemen met uw meubeldealer.

**Nasz bezpośredni serwis części montażowych**

Jeżeli brakuje części koniecznych do montażu, prosimy o przesłanie nam niniejszej karty serwisowej na niżej podany adres e-mailowy. W ten sposób możemy przesłać Państwu tylko brakujące części. W przypadku innych reklamacji dotyczących mebla, prosimy zgłosić się do salonu meblowego, w którym został dokonany zakup.

**Servis za okove**

U slučaju da nedostaje neki od dijelova molimo vas da na dolje navedenu mail adresu pošaljete ovaj servisni obrazac. Na ovaj način mogu se dostaviti samo okovi. U slučaju da imate dodatne prigovore vezane uz komad namještaja molimo vas da se obratite izravno trgovini namještaja gdje je isti kupljen.

**Direktszolgáltatunk vasalatok esetén**

Ha hiányzik egy vasalat, ezt a kártyát közvetlenül elküldheti az alább található címre. Azonban csakis vasalatókat tudunk így küldeni. Amennyiben másfajta reklamáció áll fenn bútordarabját illetően, forduljon közvetlenül a bútorházhoz.

**Náš priamy servis pre časti kovania**

Ak by Vám chýbala nejaká časť kovania, môžete poslať túto servisnú kartu poslať e-mailom na nižšie uvedenu adresu. Diely kovania vieme poslať iba týmto spôsobom. Ak by ste mali inú reklamáciu ohľadom Vášho nábytku, obráťte sa priamo na Vašu predajňu nábytku.

**Naše direktne uslužne storitve za okovje**

Če vam manjka kakšno okovje, lahko to servisno kartico pošljete po e-pošti direktno na spodnji naslov. Po tej poti vam lahko pošljemo samo okovje. Če želite reklamirati kakšen drug del pohištva, se obrnite neposredno na vašo trgovino pohištva.

**Service-ul nostru direct pentru feronerie**

În cazul în care vă lipsește o piesă de feronerie puteți să trimiteți direct acest card de service prin e-mail la adresa de mai jos. Noi nu putem expedia piese de feronerie decât pe această cale. Dacă aveți o altă reclamație referitoare la piesa de mobilier, atunci vă rugăm să vă adresați direct la magazinul dvs. de mobilă.

**Наш прямой сервис для поставок фурнитуры**

Если окажется, что Вам не хватает того или иного элемента фурнитуры, Вы можете отправить сервисную карту по факсу непосредственно на нижеприведенный адрес электронной почты. Однако, таким образом мы можем пересылать лишь фурнитуру. Если же у Вас возникнут иные претензии относительно приобретенной мебели, пожалуйста, обращайтесь непосредственно в организацию, осуществившую продажу.

**Vår direktservice för beslagsdelar**

Om du saknar en beslagsdel kan du skicka detta servicekort direkt till e-postadressen som anges nedan. Tänk på att detta är den enda möjligheten att skicka beslagsdelar till dig. Om du vill reklamera din möbel av en annan anledning måste du kontakta ditt möbelhus direkt.









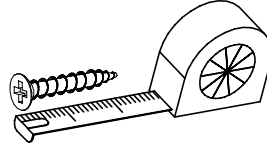



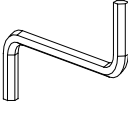

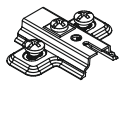
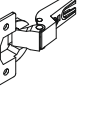
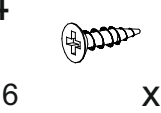
**Nuestro servicio directo para accesorios**

Si le falta algún accesorio, puede enviar esta tarjeta de servicio directamente a la siguiente dirección. No obstante, por este método solo podemos enviar accesorios. Si tiene alguna otra objeción sobre su mueble, consulte directamente con su mueblería.

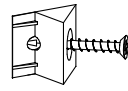
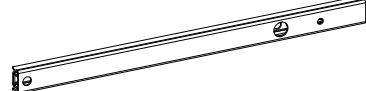

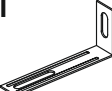

**Donatilar için doğrudan servisimiz**

Bir donatınız eksikse bu servis kartını doğrudan aşağıda bulunan adrese doğrudan mail yazabilirsiniz. Sadece bu yölla donatıları gönderebiliriz. Mobilyanızda başka şikayetleriniz varsa lütfen doğrudan mobilya satıcınıza danışın.

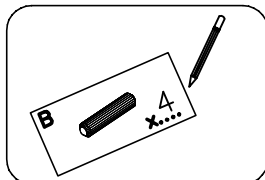

<b>B1</b>  ø8x35 X...	<b>B2</b>  ø6x30 X...	<b>A1</b>  ø7x50 X...
<b>W2</b>  X...	<b>K1</b>  X...	<b>K10</b>  X...
<b>D4</b>  X...	<b>C6</b>  X...	<b>G34</b>  3,5x16 X...
<b>G47</b>  6,3x13 X...	<b>G49</b>  4x16 X...	<b>N1</b>  M4x9 X...
<b>I1</b>  X...	<b>H5</b>  X...	
<b>W1</b>  X...	<b>M11</b>  X...	<b>G50</b>  3x20 X...
<b>P10</b>  X...	<b>G36</b>  4x30 X...	





 +49 5233 95 290 10  

 service@mv-steinheim.de

Name • Nom • Nome • Naam • Nazwa • Иméно  
• Názov • Néв • Denumire • Isim • Извание

Nr • No • N° • Номер • Č • Sz

Typ • Type • Tip • Típus • Tipo • Tun

CITY 36

— —

53

**Under Direktservice für Beschlagteile**

Sollte Ihnen ein Beschlagteil fehlen, können Sie diese Servicekarte direkt an die untenstehende Adresse mailen. Wir können allerdings nur Beschlagteile auf diesem Wege verschicken. Sollten Sie eine andere Beanstandung an Ihrem Möbelstück haben, so wenden Sie sich bitte direkt an Ihr Möbelhaus.

**Our direct order service for fitting**

If a fitting part is missing, you can e-mail this service card directly to the address below. However, we can only send fitting parts in this way. If you have any other cause for complaint concerning your item of furniture, please contact your furniture store directly.

**Naše přímé služby pro kování**

Chybí-li vám nějaký díl z kování, můžete tuto servisní kartu odeslat e-mailem přímo na níže uvedenou adresu. Touto cestou však můžeme rozesílat jen díly kování. Pokud byste reklamovali jiný díl nábytku, obraťte se přímo na svého prodejce nábytku.

**Bien etudier la notice de montage**

S'il vous manque une ferrure, veuillez envoyer directement la présente carte service à l'adresse e-mail indiquée ci-dessous. Cependant, ceci nous permet uniquement d'envoyer des ferrures. Pour tout autre type de réclamation concernant votre meuble, veuillez contacter directement votre magasin d'ameublement.

**Il nostro servizio diretto per l'ordine della ferramenta**

Qualora Vi dovesse mancare un pezzo di fissaggio, allora Vi preghiamo di inviare questa carta di servizio immediatamente all'indirizzo sottostante. Possiamo inviare i pezzi di fissaggio solamente per mezzo di questo procedimento. Qualora dovete avere qualche altra reclamazione in merito al mobile, allora Vi preghiamo di rivolgerVi direttamente al Vostro Negozio di mobili.

**Нашата директна услуга за обков**

Ако липсват части от комплекта, попълнете настоящата сервисна карта и ни я изпратете на e-mail адреса, посочен по-долу. По този начин можем да доставяме само липсващи елементи от обкова. Ако установите други дефекти по мебелите, Ви съветваме да се обърнете към мебелната къща/магазин, от който сте закупили стоката.

**Onze directservice voor losse onderdelen**

Wanneer er een onderdeel ontbreekt, kunt u deze servicekaart direct aan onderstaand e-mailadres sturen. Wij kunnen langs deze weg echter alleen beslagdelen versturen. Mocht u een ander probleem aan uw meubel hebben, verzoeken wij u contact op te nemen met uw meubeldealer.

**Nasz bezpośredni serwis części montażowych**

Jeżeli brakuje części koniecznych do montażu, prosimy o przesłanie nam niniejszej karty serwisowej na niżej podany adres e-mailowy. W ten sposób możemy przesłać Państwu tylko brakujące części. W przypadku innych reklamacji dotyczących mebla, prosimy zgłosić się do salonu meblowego, w którym został dokonany zakup.

**Servis za okove**

U slučaju da nedostaje neki od dijelova molimo vas da na dolje navedenu mail adresu pošaljete ovaj servisni obrazac. Na ovaj način mogu se dostaviti samo okovi. U slučaju da imate dodatne prigovore vezane uz komad namještaja molimo vas da se obratite izravno trgovini namještaja gdje je isti kupljen.

**Direktszolgálatunk vasalatok esetén**

Ha hiányzik egy vasalat, ezt a kártyát közvetlenül elküldheti az alább található címre. Azonban csakis vasalatoskat tudunk így küldeni. Amennyiben másfajta reklamáció áll fenn bűtorárabját illetően, forduljon közvetlenül a bűtorházhoz.

**Náš priamy servis pre časti kovania**

Ak by Vám chýbala nejaká časť kovania, môžete poslať túto servisnú kartu poslať e-mailom na nižšie uvedenú adresu. Diely kovania vieme poslať iba týmto spôsobom. Ak by ste mali inú reklamáciu ohľadom Vášho nábytku, obráťte sa priamo na Vašu predajňu nábytku.

**Naše direktne uslužne storitve za okovje**

Če vam manjka kakšno okovje, lahko to servisno kartico pošljete po e-pošti direktno na spodnji naslov. Po tej poti vam lahko pošljemo samo okovje. Če želite reklamirati kakšen drug del pohištva, se obrnite neposredno na vašo trgovino pohištva.

**Service-ul nostru direct pentru feronerie**

În cazul în care vă lipsește o piesă de feronerie puteți să trimiteți direct acest card de service prin e-mail la adresa de mai jos. Noi nu putem expedia piese de feronerie decât pe această cale. Dacă aveți o altă reclamație referitoare la piesa de mobilier, atunci vă rugăm să vă adresați direct la magazinul dvs. de mobilă.

**Наш прямой сервис для поставок фурнитуры**

Если окажется, что Вам не хватает того или иного элемента фурнитуры, Вы можете отправить сервисную карту по факсу непосредственно на нижеприведенный адрес электронной почты. Однако, таким образом мы можем пересылать лишь фурнитуру. Если же у Вас возникнут иные претензии относительно приобретенной мебели, пожалуйста, обращайтесь непосредственно в организацию, осуществившую продажу.

**Vår direktservice för beslagsdelar**

Om du saknar en beslagsdel kan du skicka detta servicekort direkt till e-postadressen som anges nedan. Tank på att detta är den enda möjligheten att skicka beslagsdelar till dig. Om du vill reklamera din möbel av en annan anledning måste du kontakta ditt möbelhus direkt.

**Nuestro servicio directo para accesorios**

Si le falta algún accesorio, puede enviar esta tarjeta de servicio directamente a la siguiente dirección. No obstante, por este método solo podemos enviar accesorios. Si tiene alguna otra objeción sobre su mueble, consulte directamente con su mueblería.

**Donatilar için doğrudan servisimiz**

Bir donatınız eksikse bu servis kartını doğrudan aşağıda bulunan adrese doğrudan mail yazabilirsiniz. Sadece bu yolla donatılarınızı gönderilebiliriz. Mobilyanızda başka şikayetleriniz varsa lütfen doğrudan mobilya satıcınıza danışın.

nr	L[mm]	B[mm]	T[mm]	Menge	Colli
1	535	400	16	1	1/1
2	535	400	16	1	1/1
3	468	366	16	1	1/1
4	468	362	16	1	1/1
5	468	77	38	1	1/1
6	468	80	16	1	1/1
7	462	353	16	1	1/1
8	462	126	16	1	1/1
9	290	80	12	1	1/1
10	290	80	12	1	1/1
11	436	65	12	1	1/1
12	446	297	3	1	1/1
13	505	478	3	1	1/1

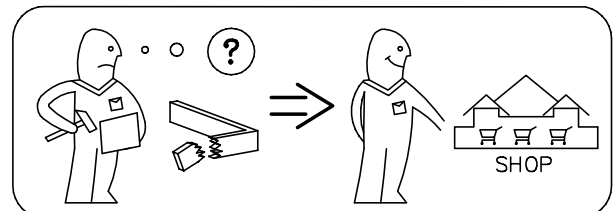
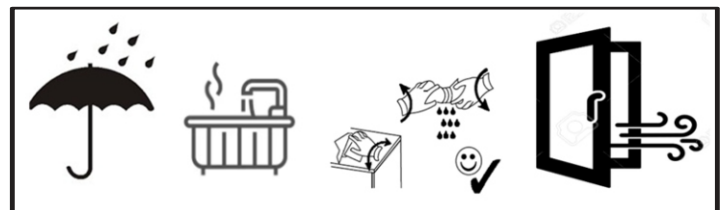
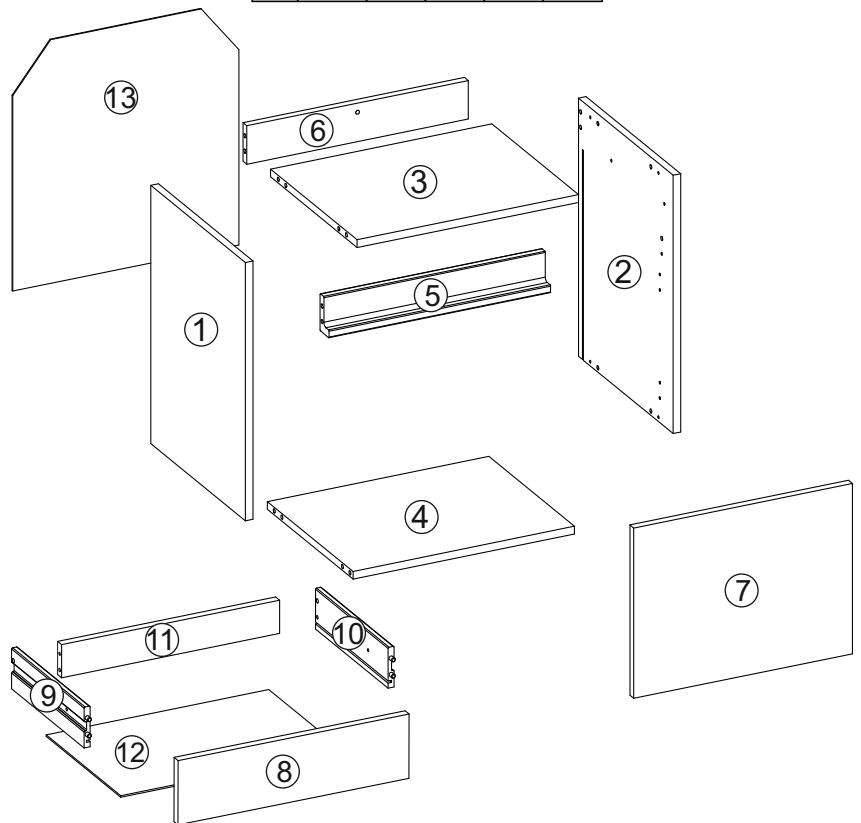

D

GB

CZ

F

I

BG

NL

PL

HR

HU

SK

SLO

RO

RUS

S

ES

TR