

»1363«

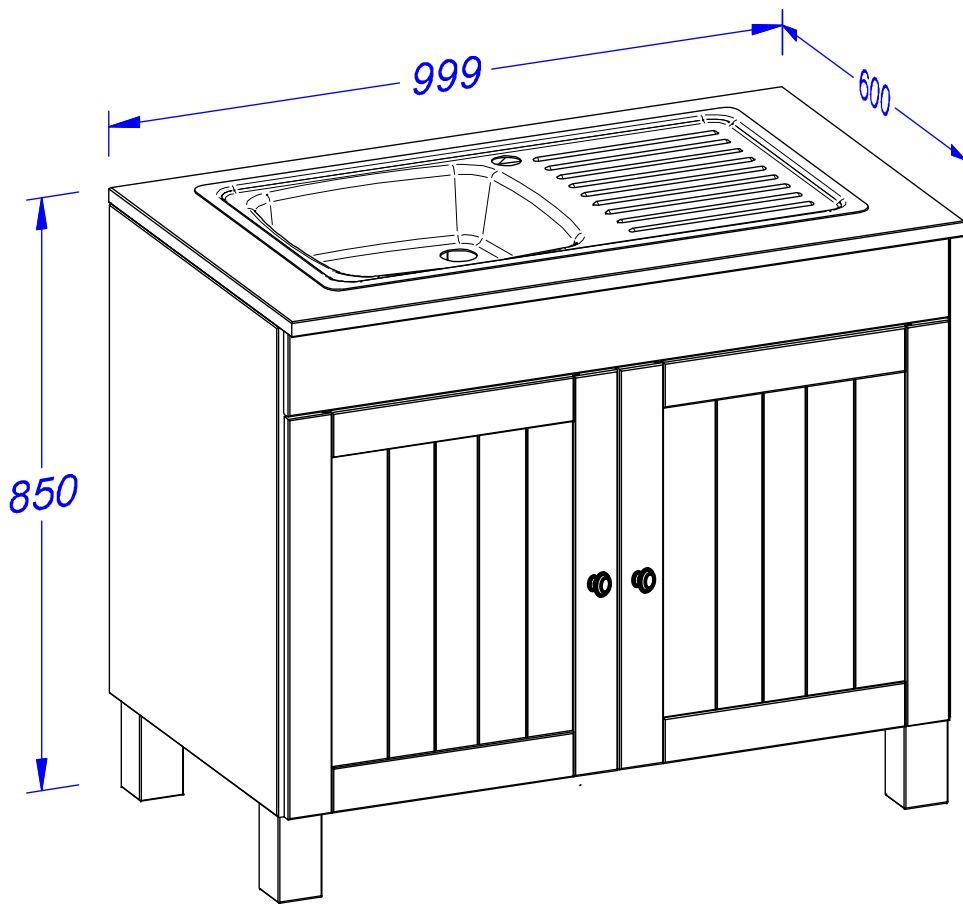

(D) *Montageanleitung*

(NL) *Handleiding voor de montage*

(TR) *Montaj talimatı*

(FR) *Notice de montage*

(CZ) *Montážní návod*

(HU) *Szerelési útmutató*

(GB) *Assembly instructions*

(PL) *Instrukcja montażu*

(RU) *Инструкция по монтажу*

(IT) *Istruzioni di montaggio*

(SK) *Návod na montáž*

(RO) *Instrucțiuni de montaj*









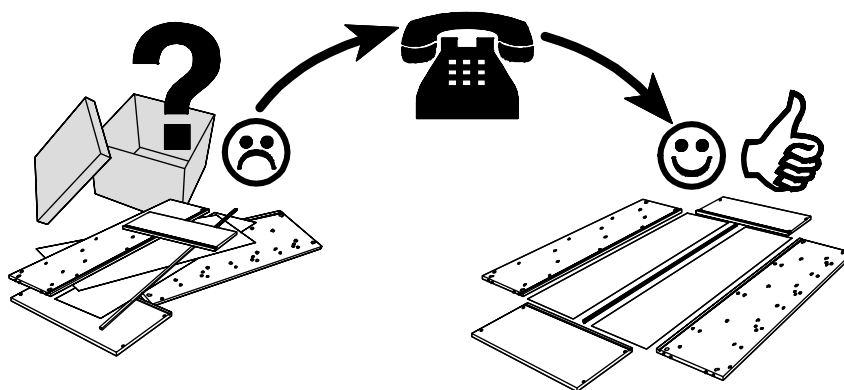
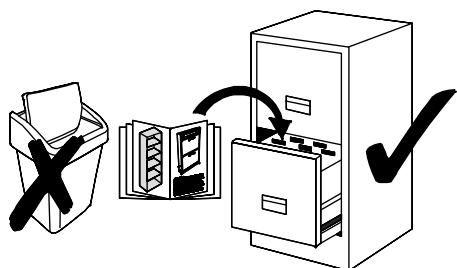

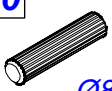
Service • Dienstverlening • Serwis • Servis • Сервисная служба • Assistenza • Szerviz

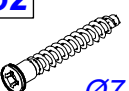
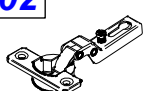
Name • Nom • Nome • Naam • Nazwa • Jméno •
Názov • Név • Denumire • Isim • Название

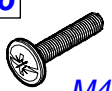
Nr. • No. • N° • Номер • Č • Sz

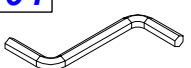
Typ • Type • Tip • Tipus • Тiпо • Тип

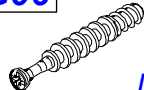
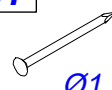

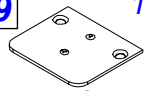

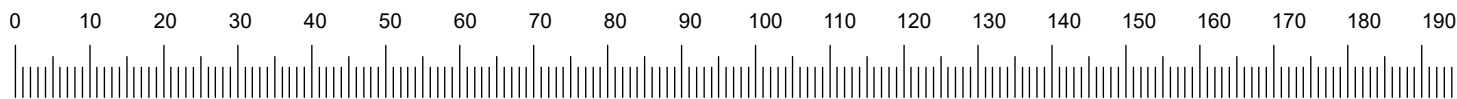
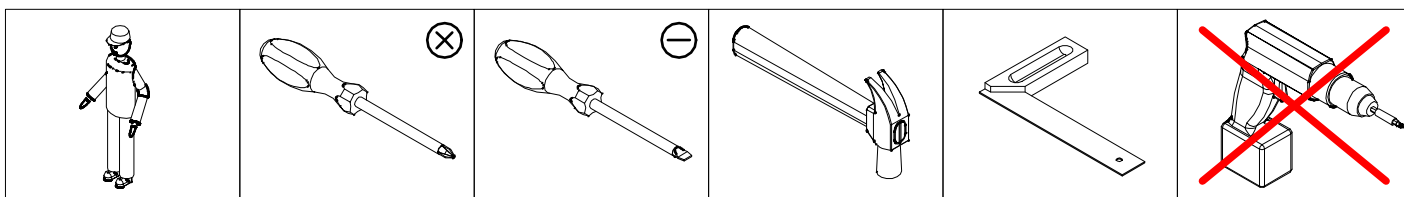

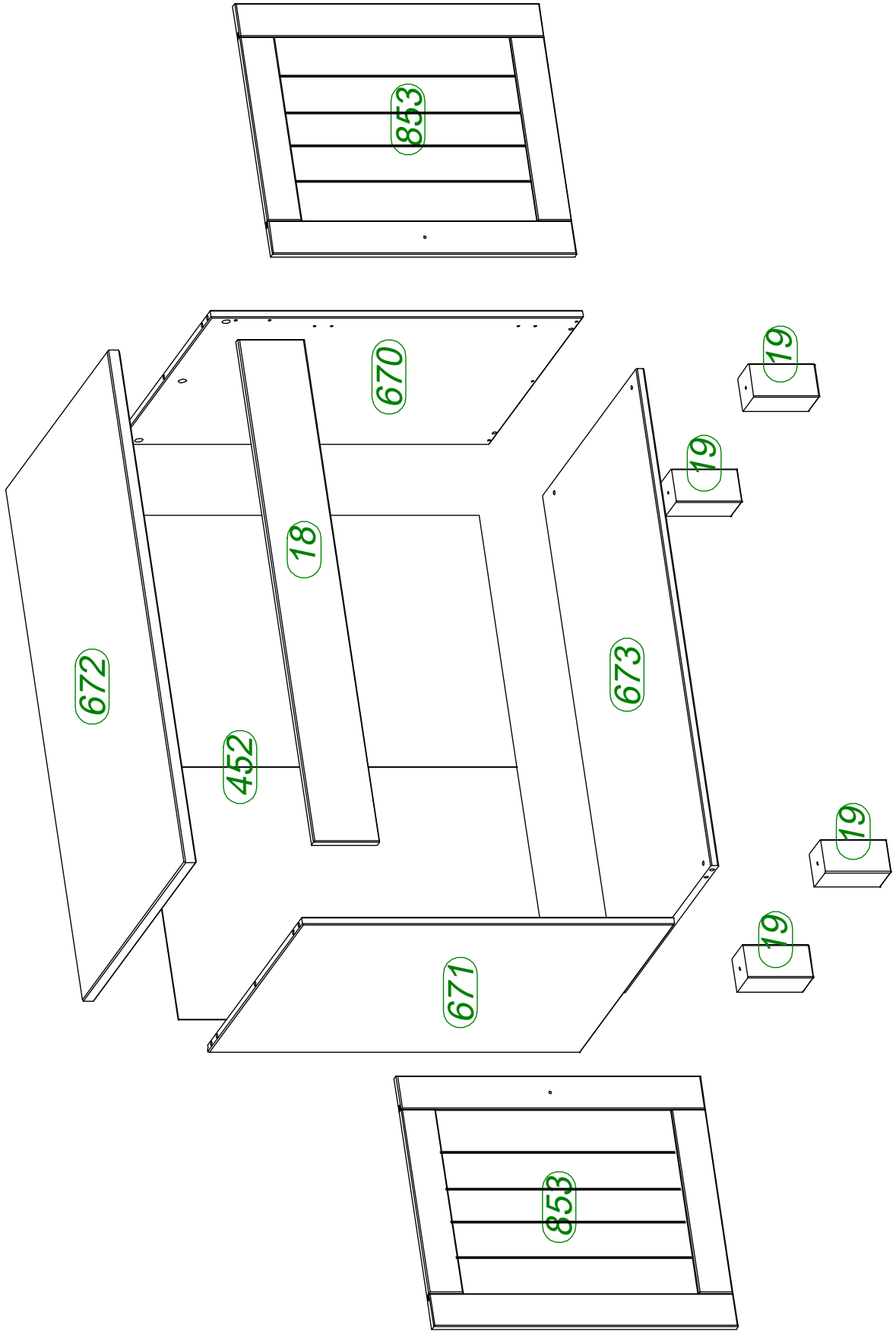
A10 8 x  Ø8 x 35	B06 8 x  Ø6,3 x 12	B52 4 x  Ø7 x 50	C02 4 x  fk.9	C20 4 x  2 mm	D06 2x  M4 x 20
E17 10 x  Ø3,5 x 15	F04 1 x  4 mm	F08 1 x  45 x 20 x 16	G02 12 x  Ø15 x 11	G06 12 x  L - 34	I01 50 x  Ø1,2 x 20
K01 4 x  20 x 20 x 16 / 6,5	P23 2 x  Ø30x21	R19 1 x  35 x 40			

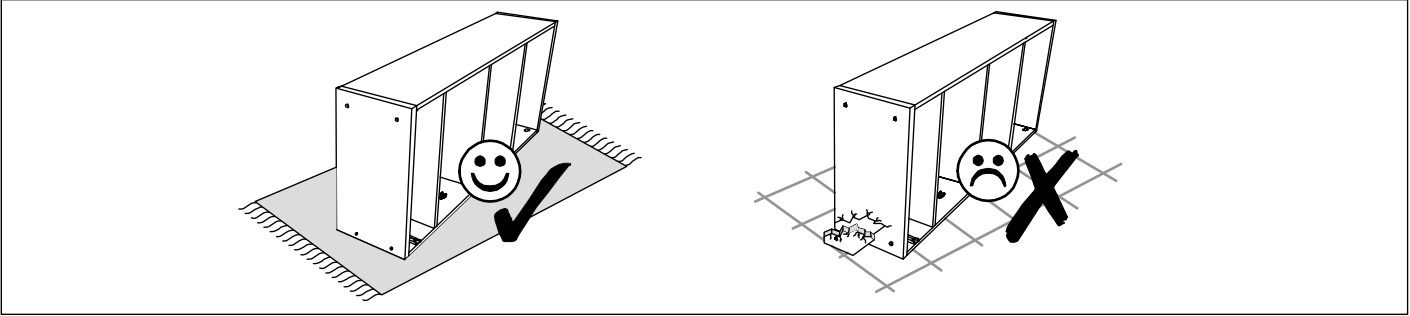



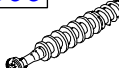

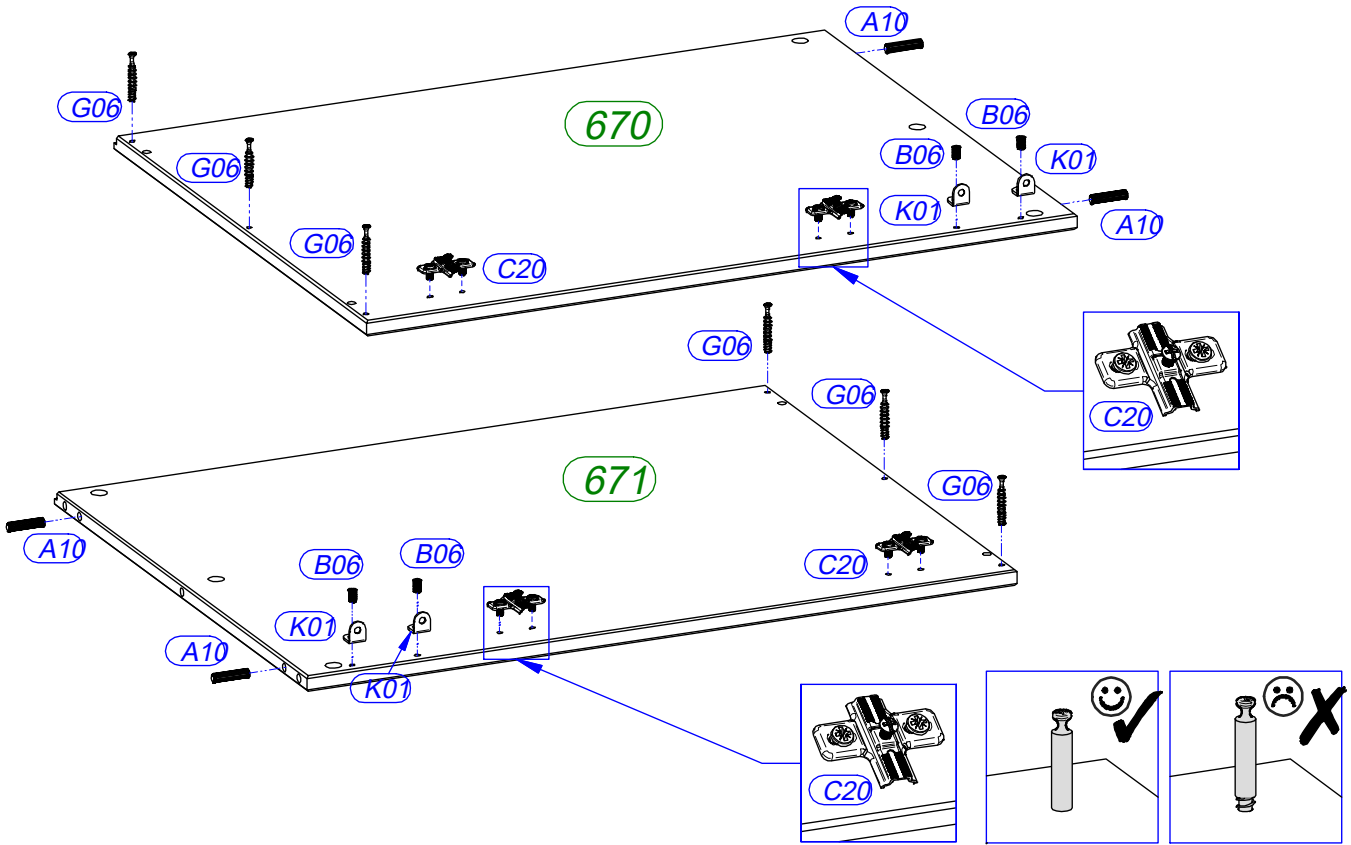

A10	4 x	B06	4 x	C20	4 x	G06	6 x	K01	4 x
									
$\varnothing 8 \times 35$		$\varnothing 6,3 \times 12$		2 mm		L - 34		20 x 20 x 16 / 6,5	



1

A10	4 x	E17	2 x	R19	1 x
					
$\varnothing 8 \times 35$		$\varnothing 3,5 \times 15$		35 x 40	

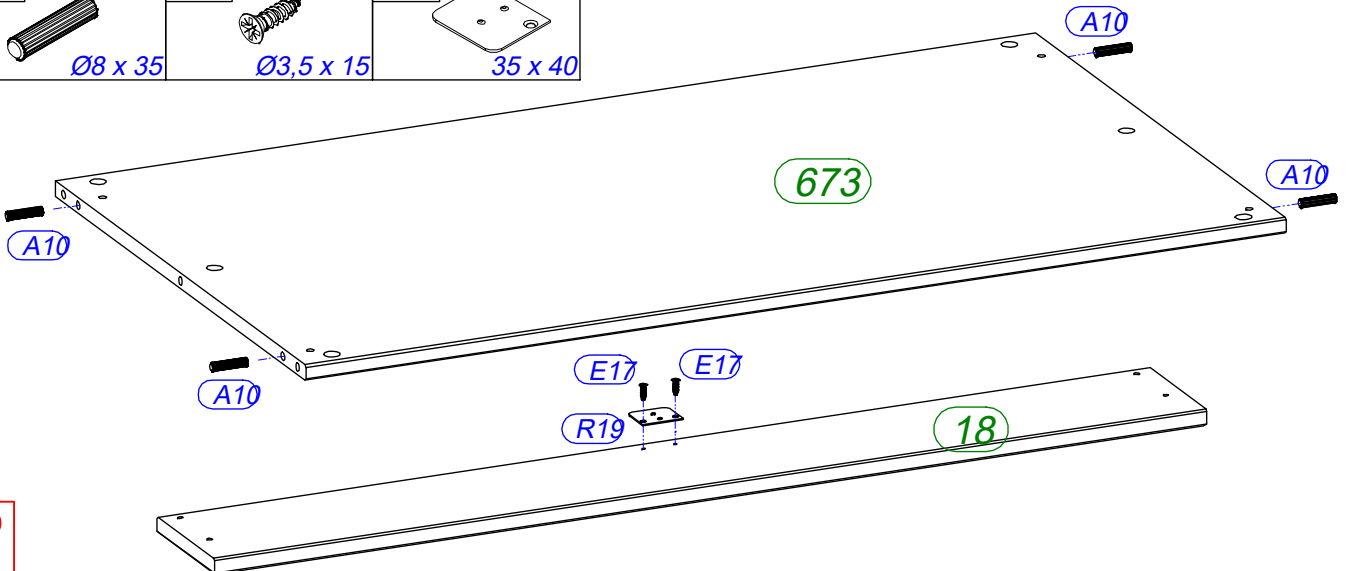

2

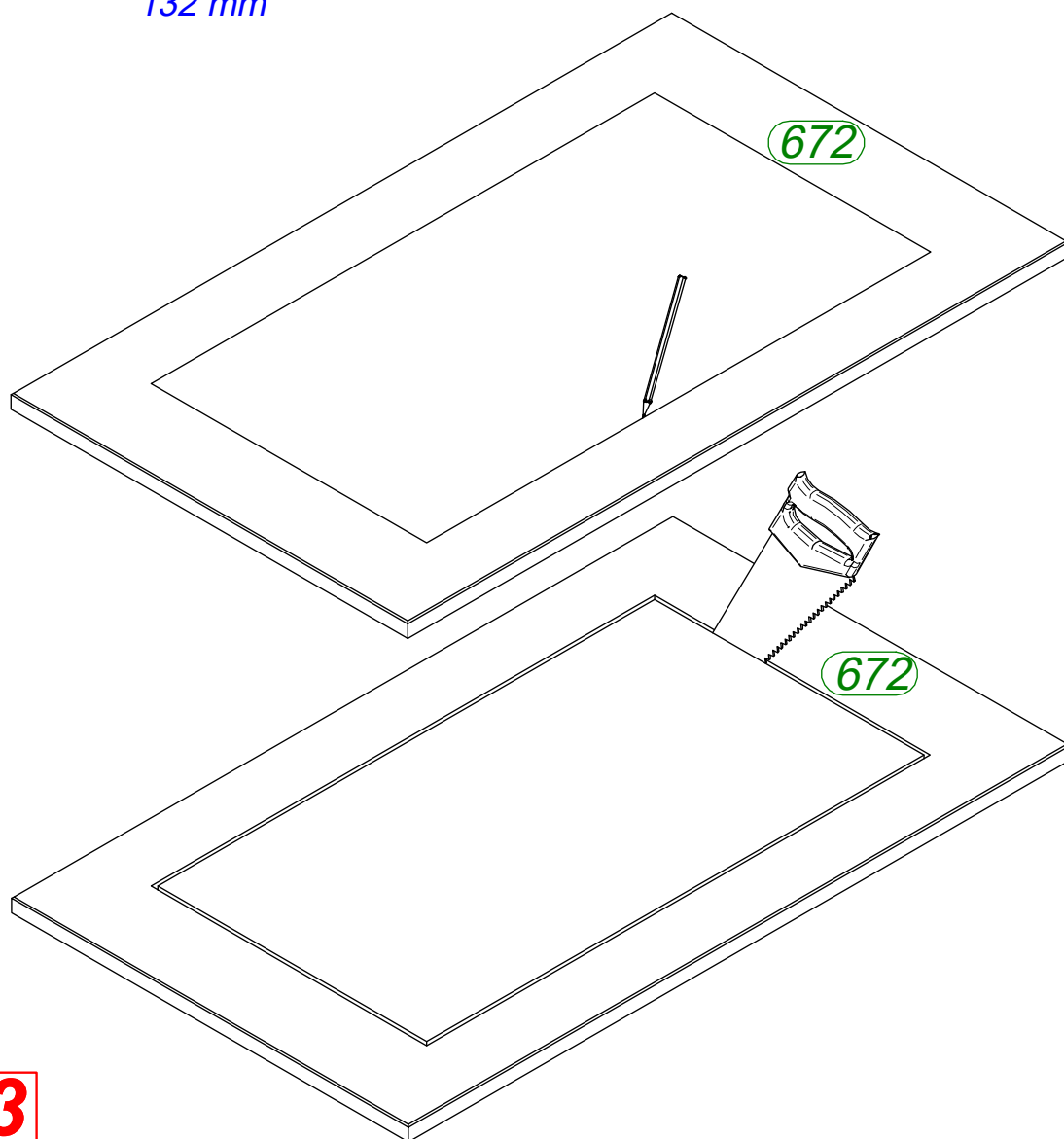
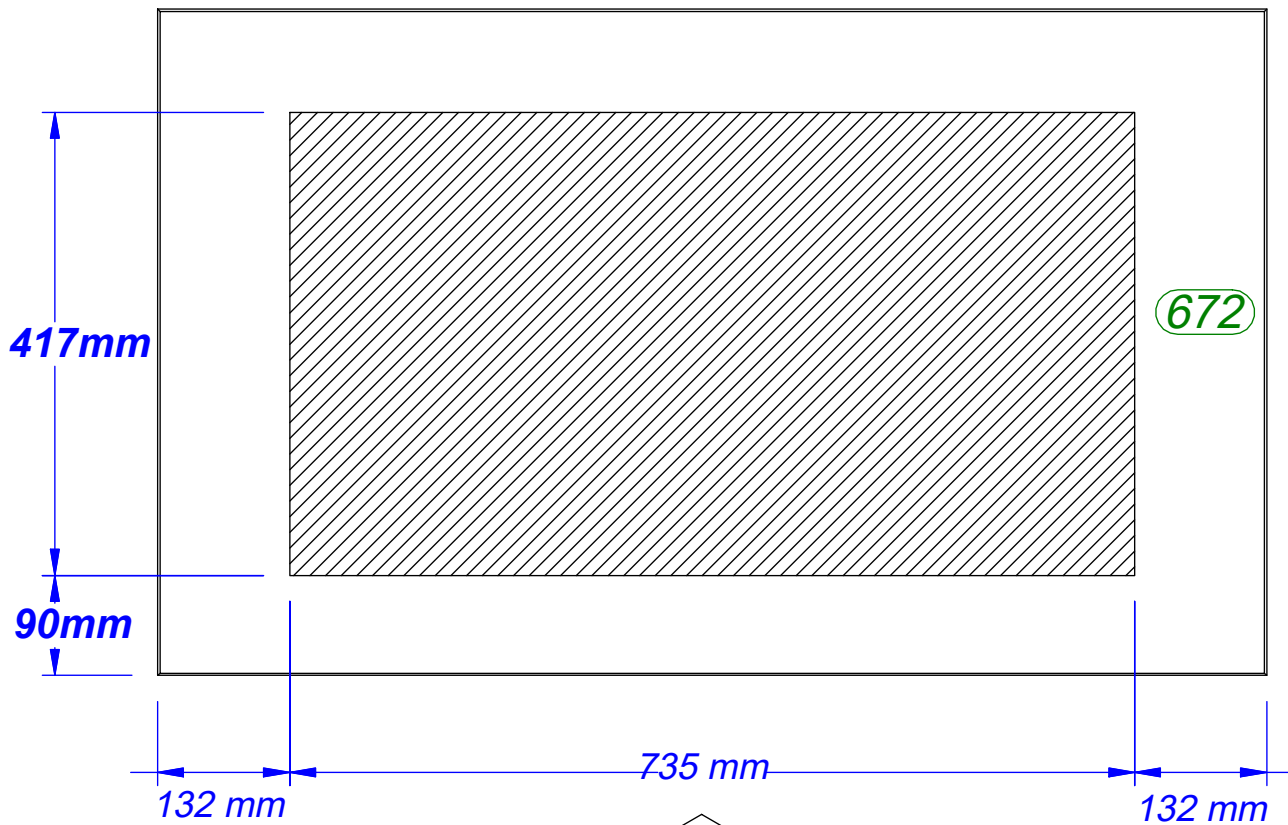

3

Achtung • Attention • Attenzione • Opgelet • Uwaga • Pozor • Figyelem • Atenție • Dikkat • Вниманіе

(D)	Bitte montieren Sie das Spülbecken auf der Topplatte laut Aufbauanleitung des Spülbeckens als erstes.
(GB)	Please mount the basin onto the top plate first, as described in the manual.
(NL)	Plaats de bak eerst op de bovenste plaat zoals beschreven in de handleiding.
(PL)	W pierwszej kolejności zamontować zlewozmywak na górnym blacie zgodnie z instrukcją montażu zlewozmywaka.
(TR)	İlk önce, kullanım kılavuzunda tanımladığı üzere evyenin en üst tabaka üzerinde kurulumunu gerçekleştirin.
(RU)	Сначала установите резервуар на верхнюю плиту как описано в руководстве.
(FR)	S'il vous plaît installer le bassin sur la plaque du haut d'abord, comme décrit dans le manuel.
(IT)	Si prega di montare il bacino sulla piastra superiore, come descritto nel manuale.
(CZ)	Prosím, držák pánve na horní desce první, jak je popsáno v manuálu.
(SK)	Prosím, držiak panvice na hornej doske prvé, ako je popísané v manuáli.
(HU)	Kérjük, szerelje fel a medencét rá a felső lemez első, ahogy az a kézikönyvben.
(RO)	Vă rugăm să mount bazinul pe placa de top în primul rând, așa cum este descris în manual.

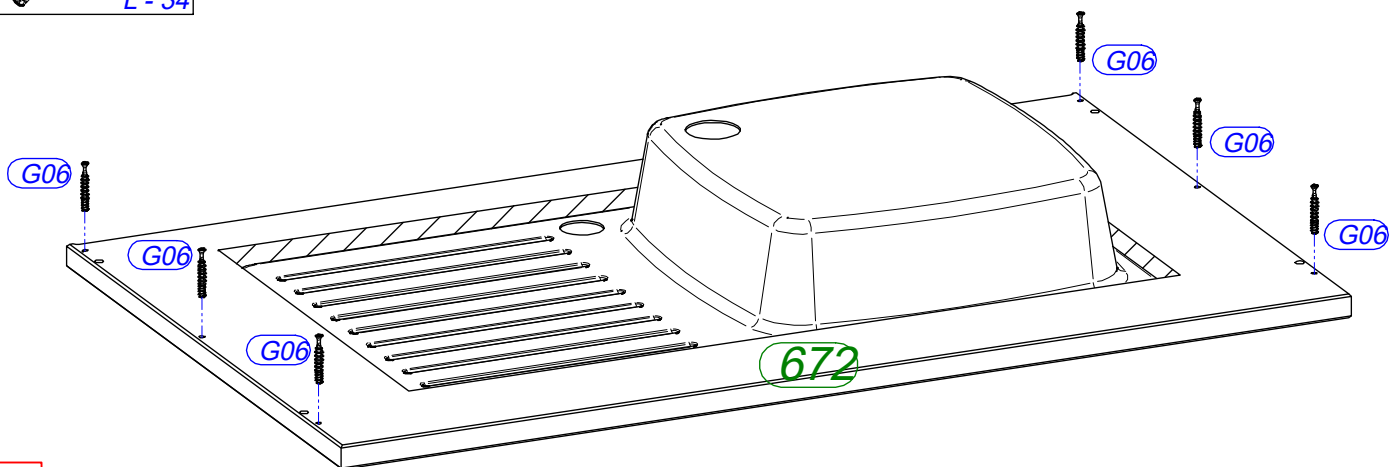
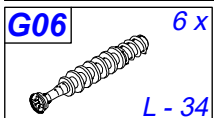

4

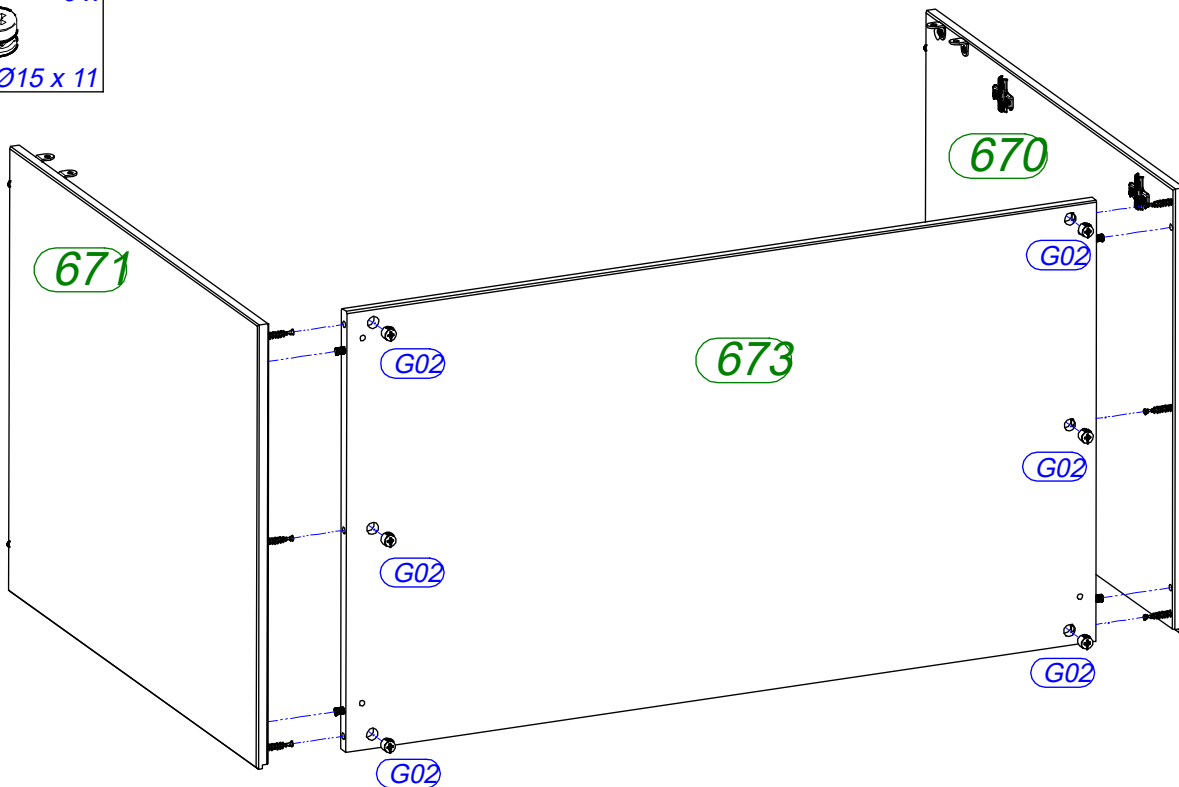
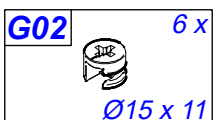

5

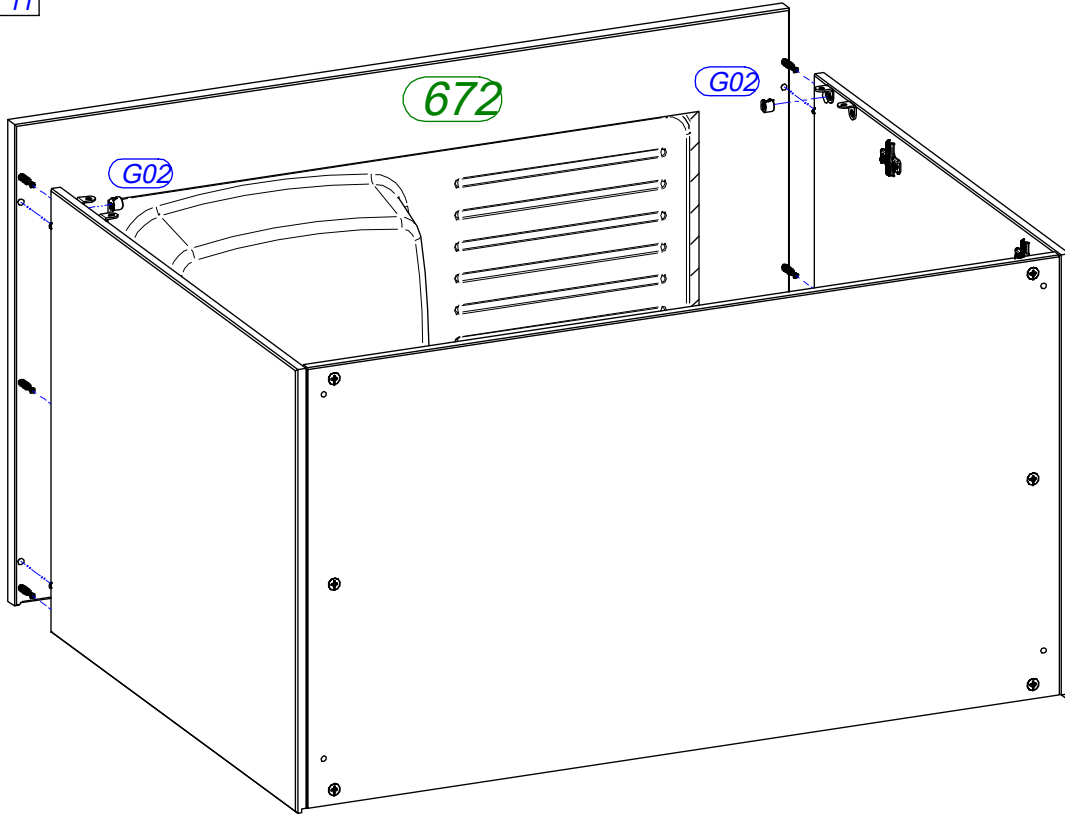
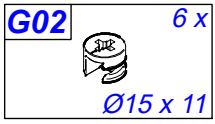

6

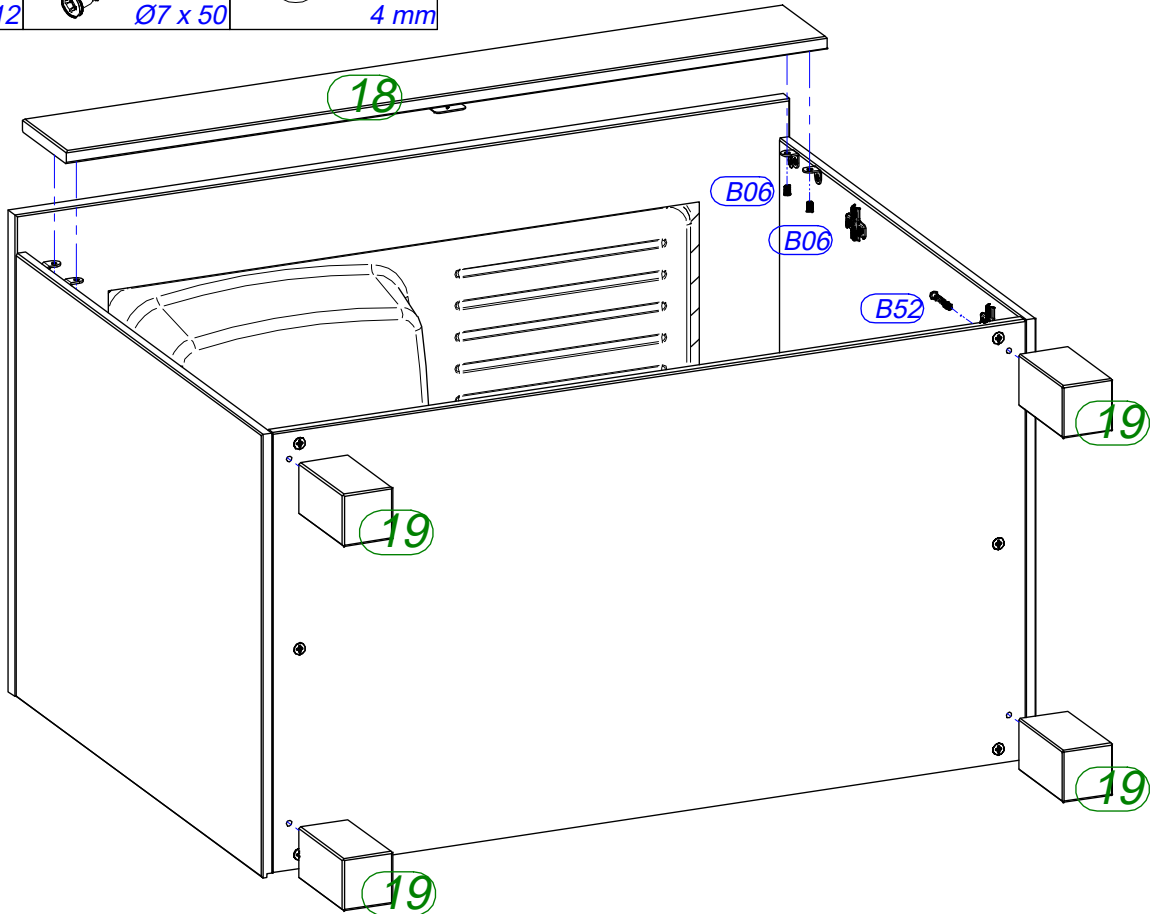
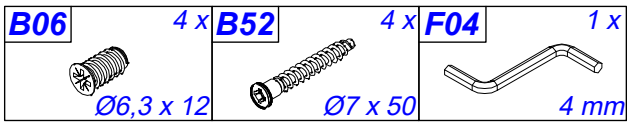

7

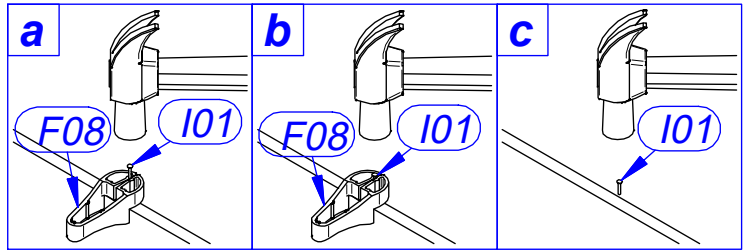
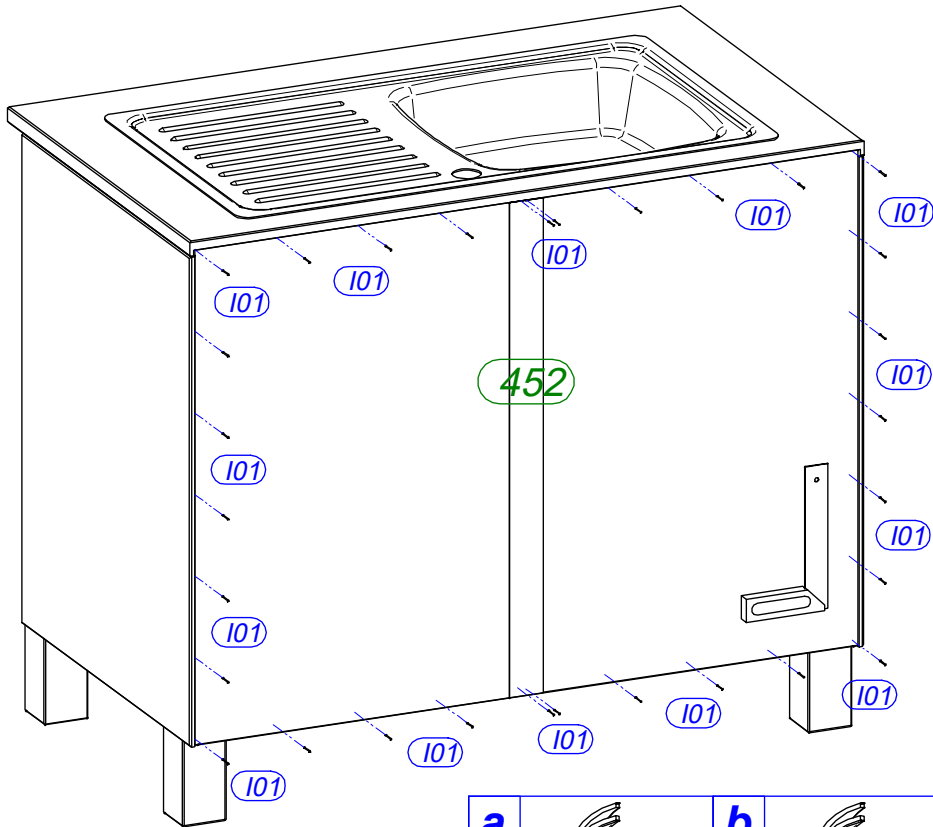
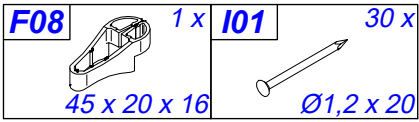

8

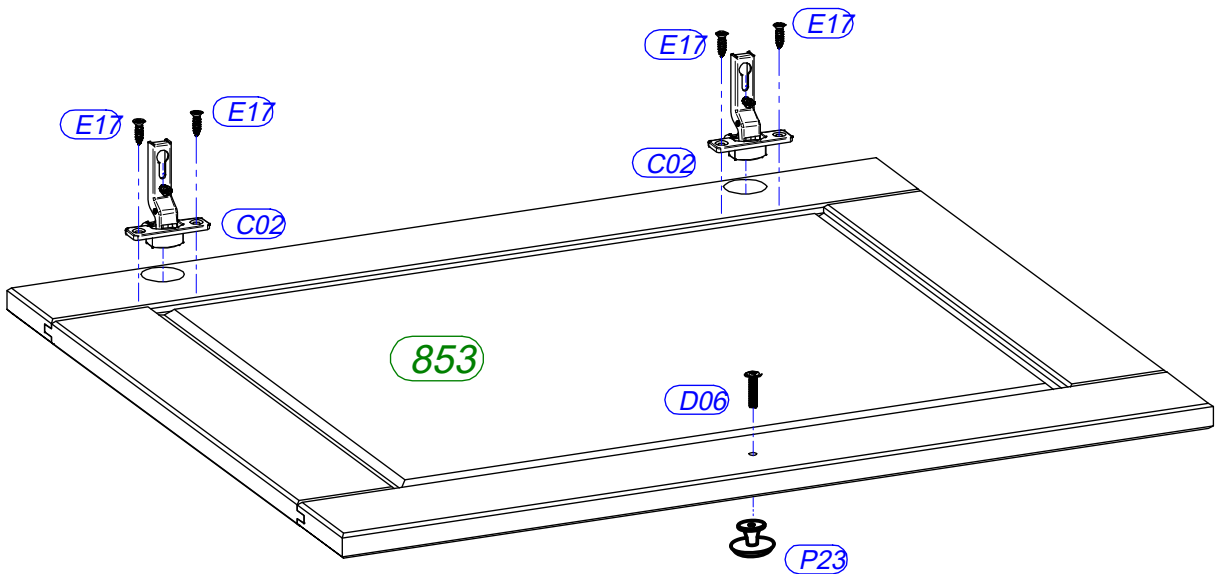
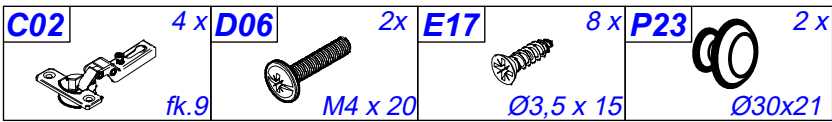

9x 2

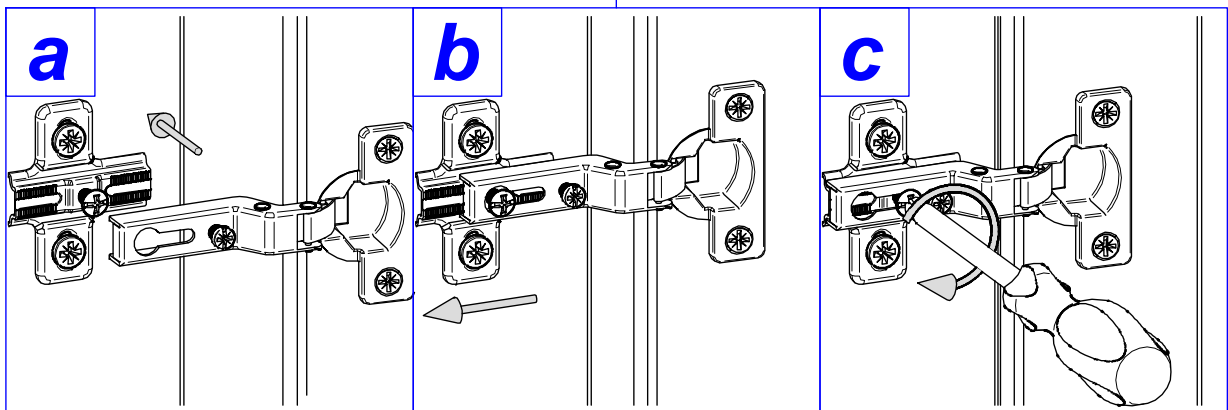
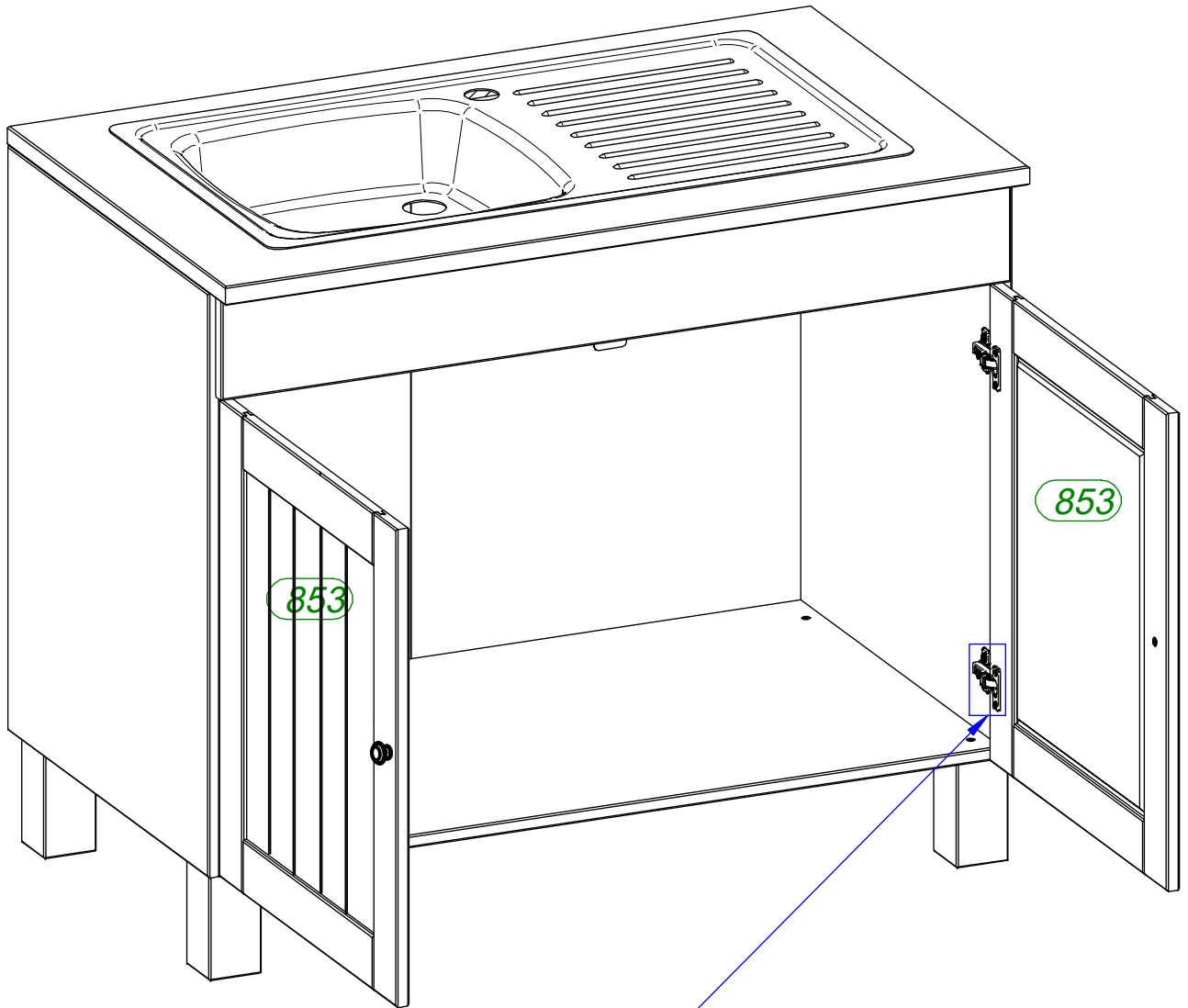

10

! Achtung • Attention • Attenzione • Opgelet • Uwaga • Pozor • Figyelem • Atenție • Dikkat • Внимание !

(D)	Türen einstellen (Scharniere justieren)
(GB)	Adjusting the doors (adjusting the hinges)
(NL)	Deuren instellen (scharnieren afstellen)
(PL)	Nastawić drzwi (wyrównać zawiasy)
(TR)	Kapıların ayarlanması (menteşelerin seviye ayarı)
(RU)	Регулировка дверей (регулировка шарнира)
(FR)	Régler les portes (ajuster les charnières)
(IT)	Sistemare le porte (regolare le cerniere)
(CZ)	Vyrovnejte dvířka (seřídte závěsy)
(SK)	Nastavenie dverí (nastavenie závesov)
(HU)	Állítsa be az ajtókat (állítsa be a zsanérokot)
(RO)	Reglare ușii (ajustare balamale)

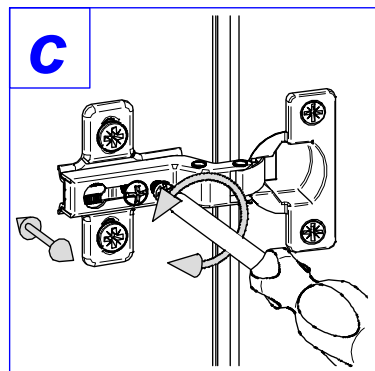
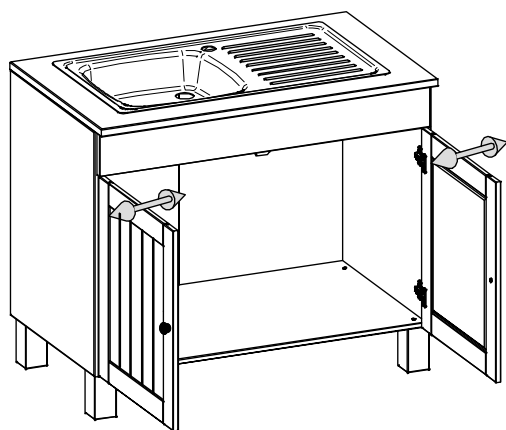
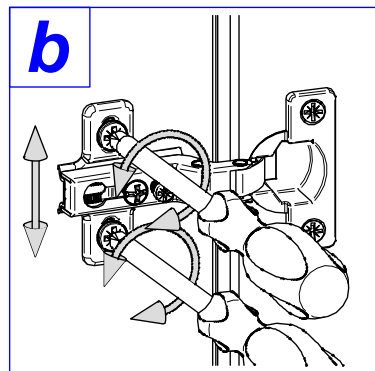
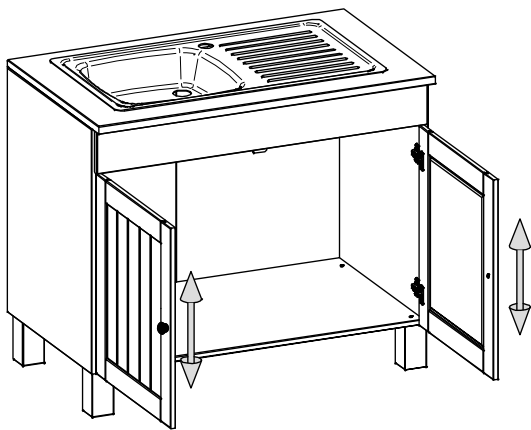
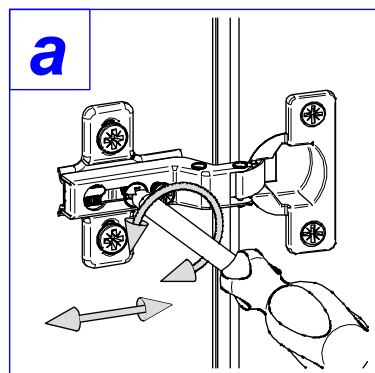
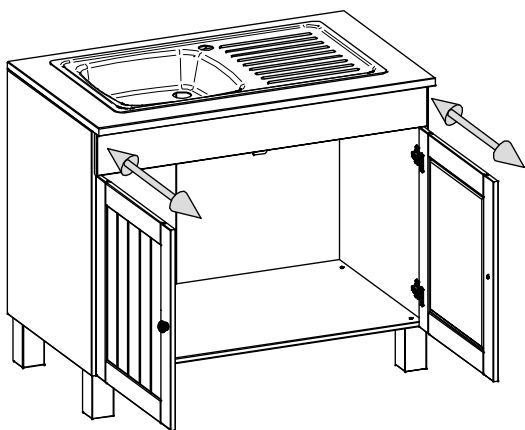

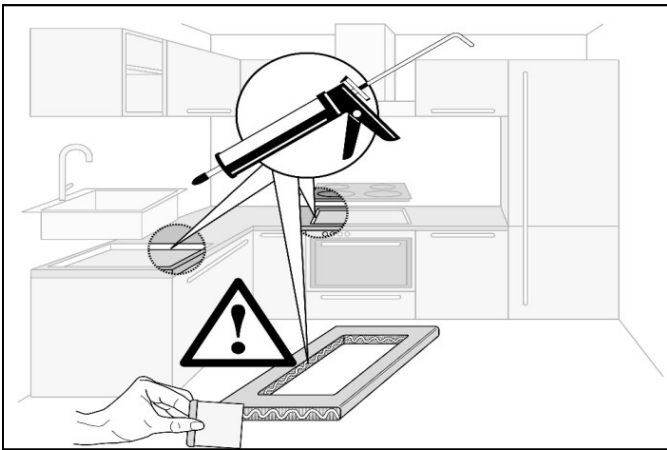
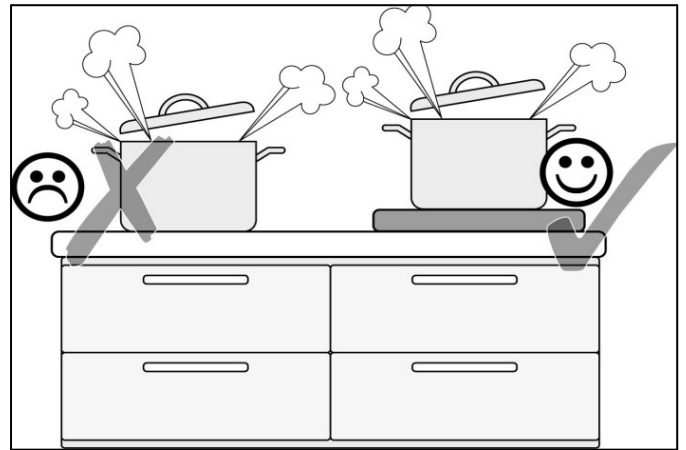
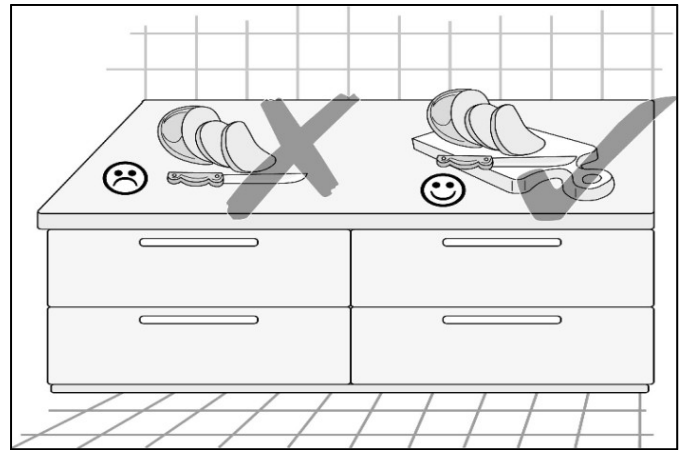
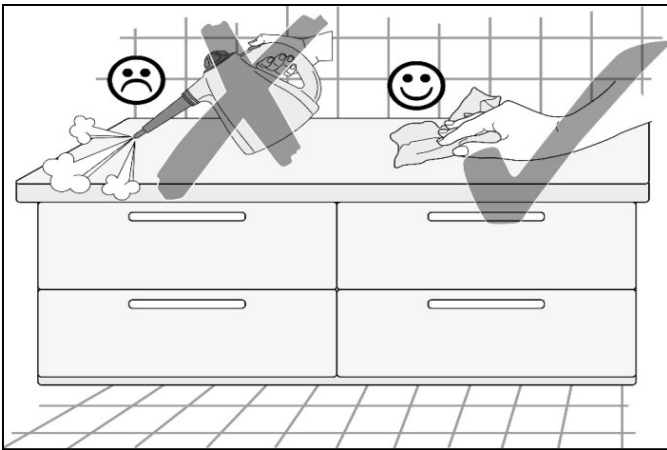
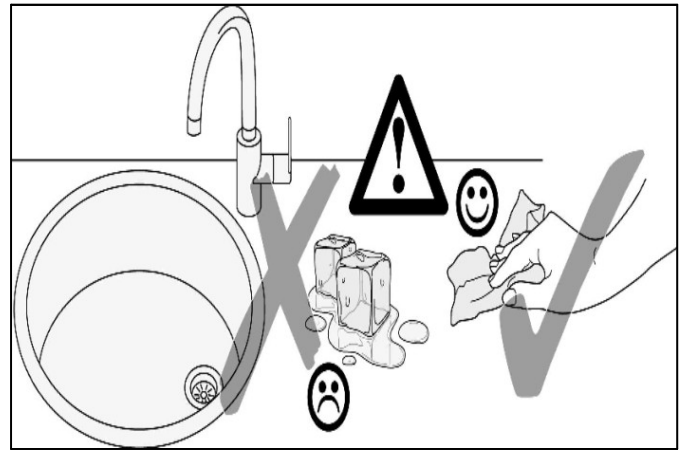
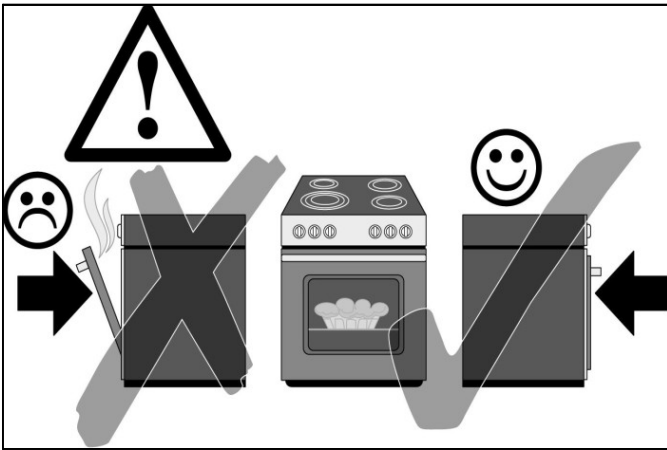

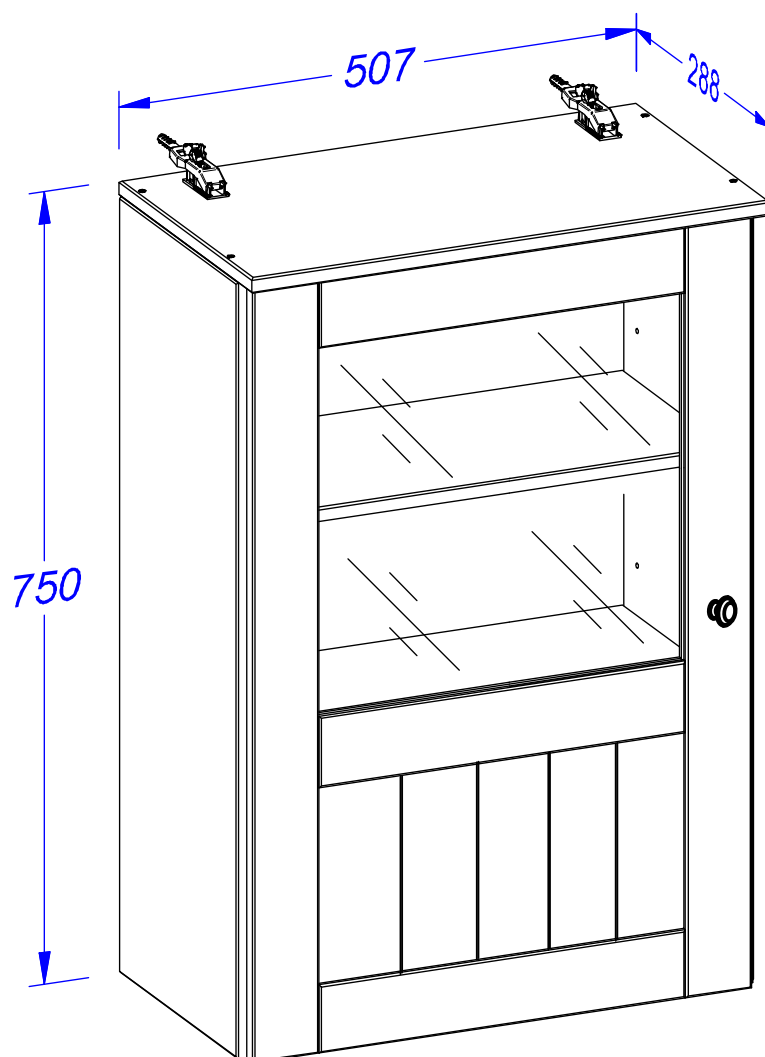

(D) *Montageanleitung*

(NL) *Handleiding voor de montage*

(TR) *Montaj talimatı*

(FR) *Notice de montage*

(CZ) *Montážní návod*

(HU) *Szerelési útmutató*

(GB) *Assembly instructions*

(PL) *Instrukcja montażu*

(RU) *Инструкция по монтажу*

(IT) *Istruzioni di montaggio*

(SK) *Návod na montáž*

(RO) *Instrucțiuni de montaj*

Service • Dienstverlening • Serwis • Servis • Сервисная служба • Assistenza • Szerviz

Name • Nom • Nome • Naam • Nazwa • Jméno •
Názov • Név • Denimire • Isim • Название

Nr. • No. • N° • Номер • Č • Sz

Typ • Type • Tip • Tipus • Тиро • Тип

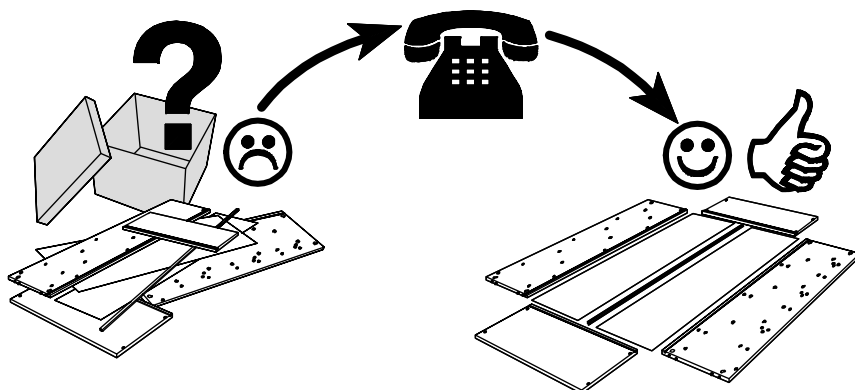
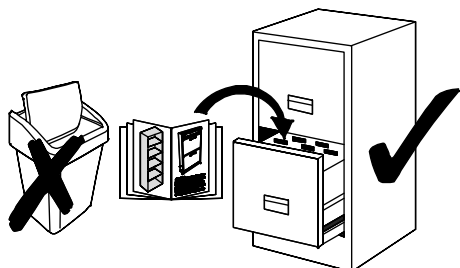

A	8 x	C	2 x	Ce	2 x	Dd	1 x	Ea	4 x	Fb	1 x
	Ø8 x 35		2 mm		fk.9		M4 x 20		Ø3,5 x 15		3 mm
G	4 x	Ga	4 x	Hc	4 x	I	25 x	lb	1 x	Lk	1 x
	L - 34		Ø15 x 11		Ø5 x 50		Ø1,2 x 20		45 x 20 x 16		2 set
N	8 x	No	1 x								
	Ø5 / Ø5		Ø30x21								

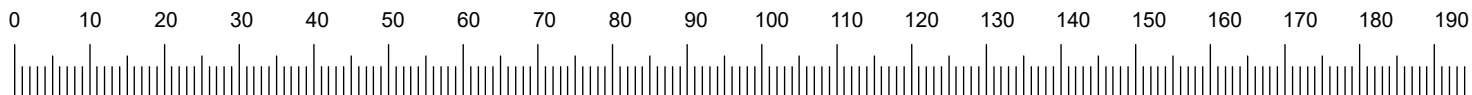
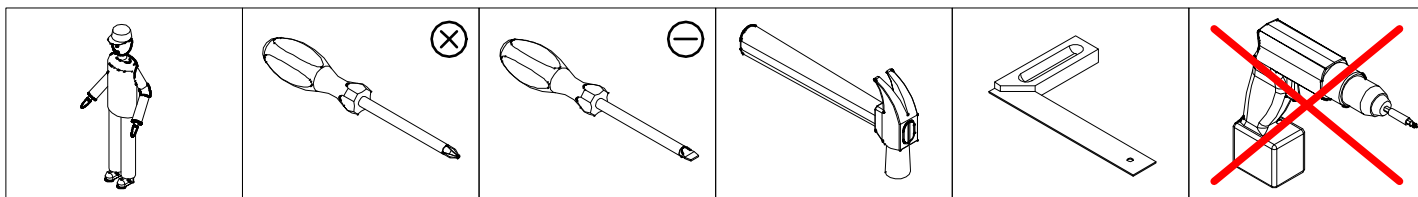

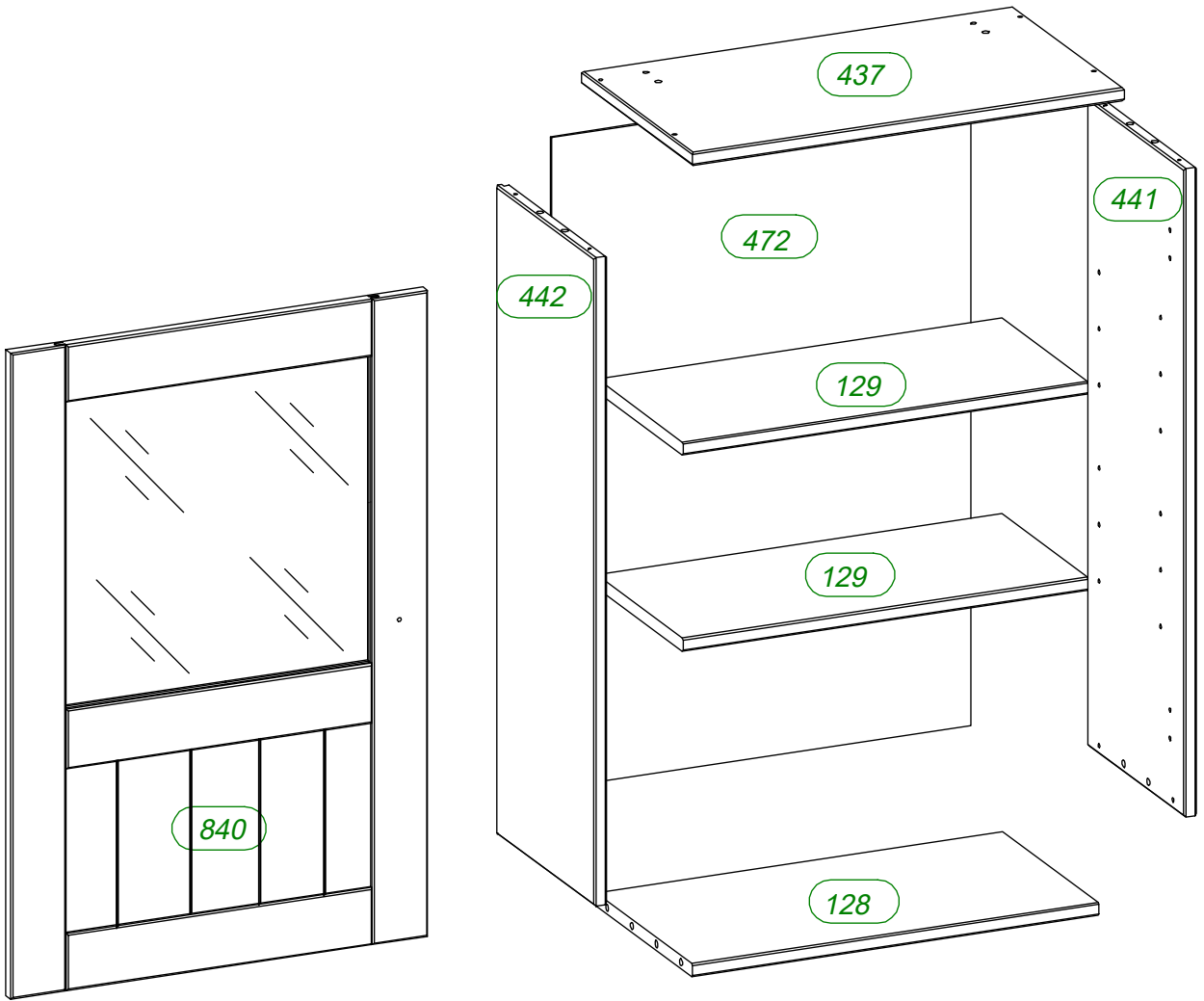

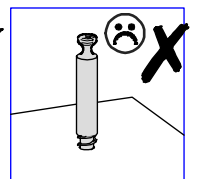
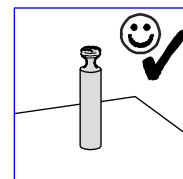
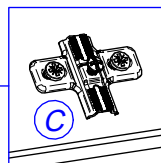
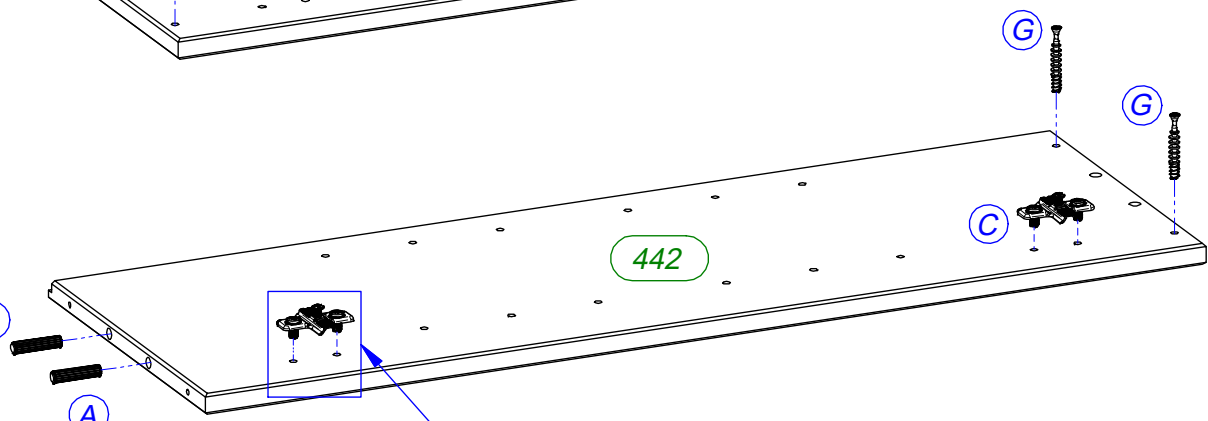
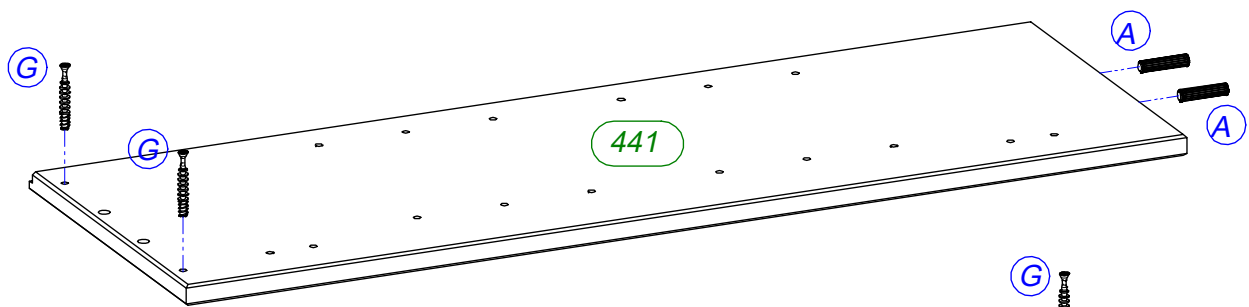
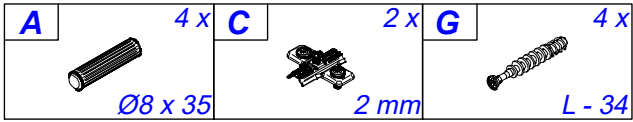
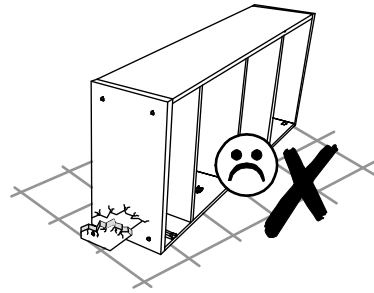
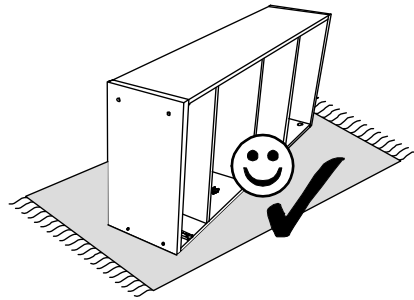

1

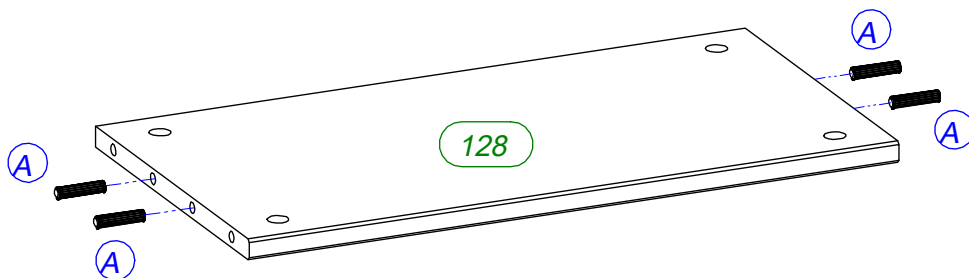
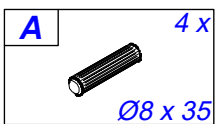

2

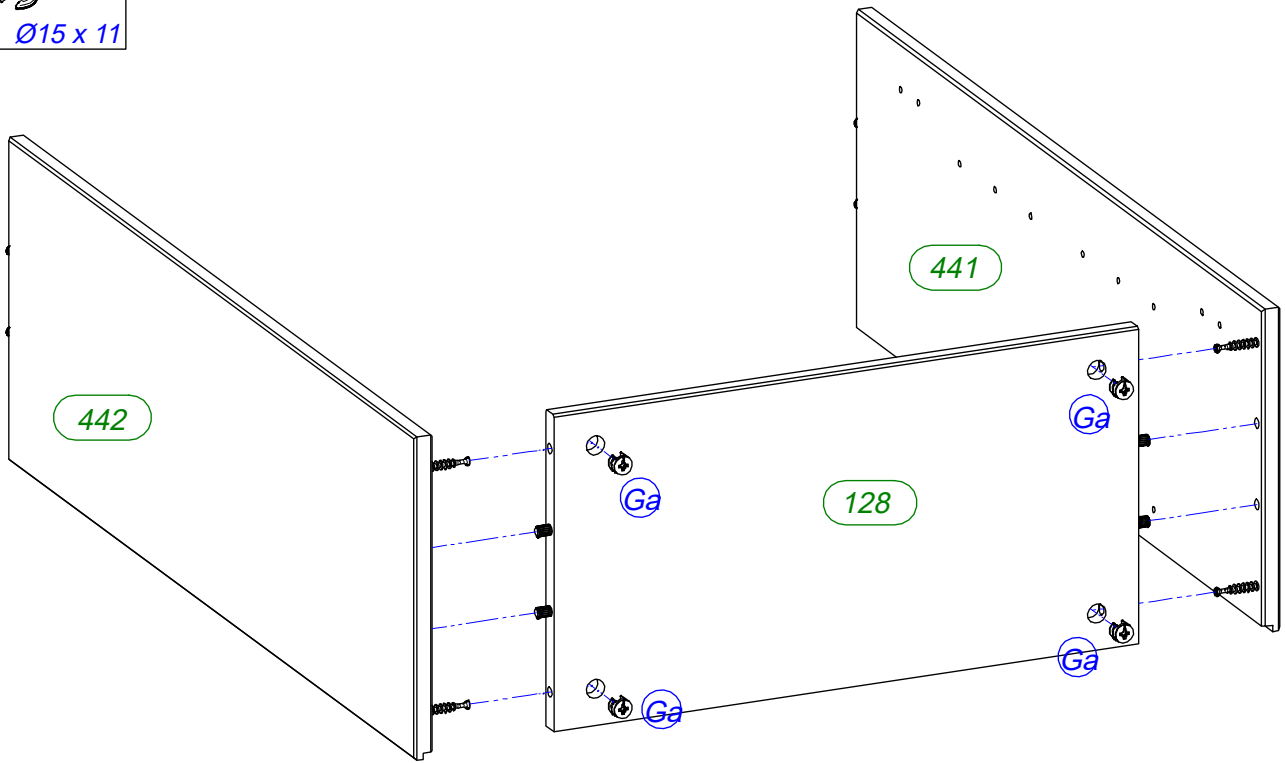
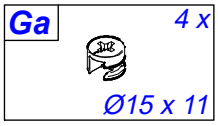

3

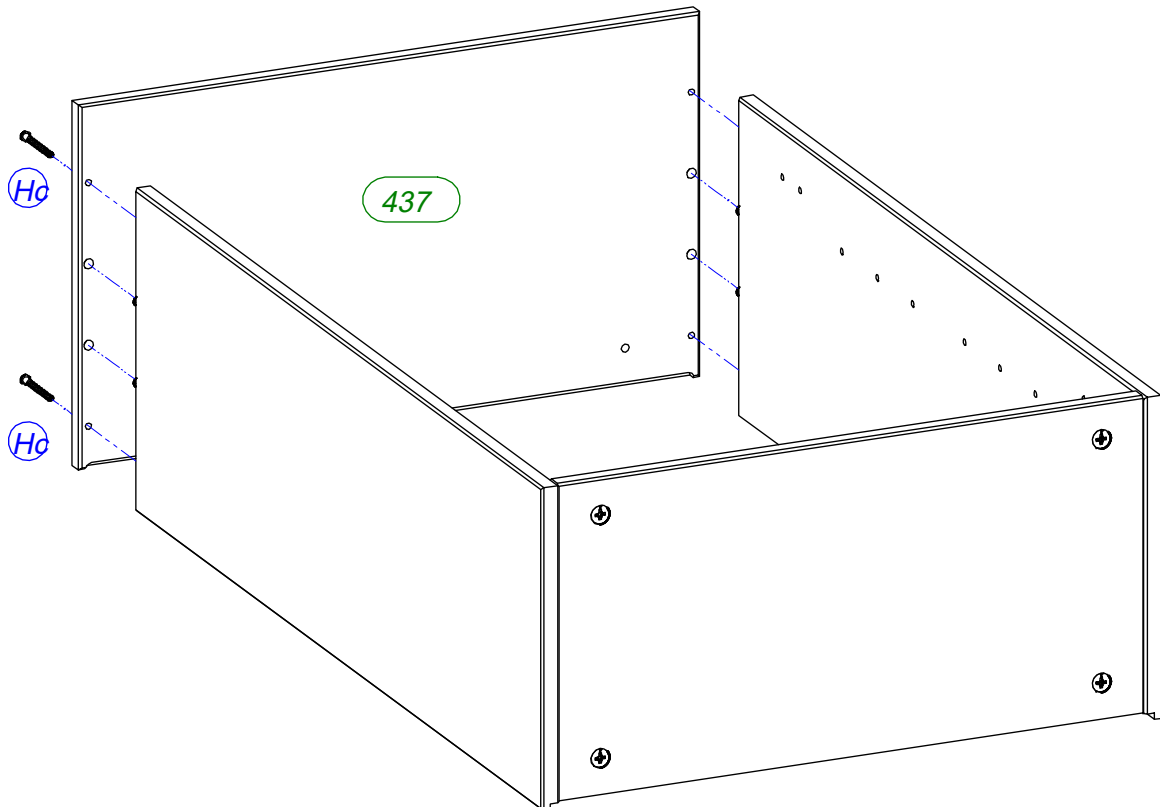
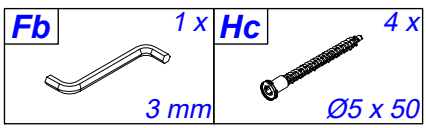



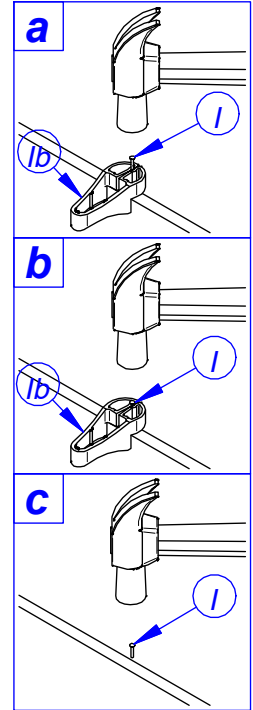
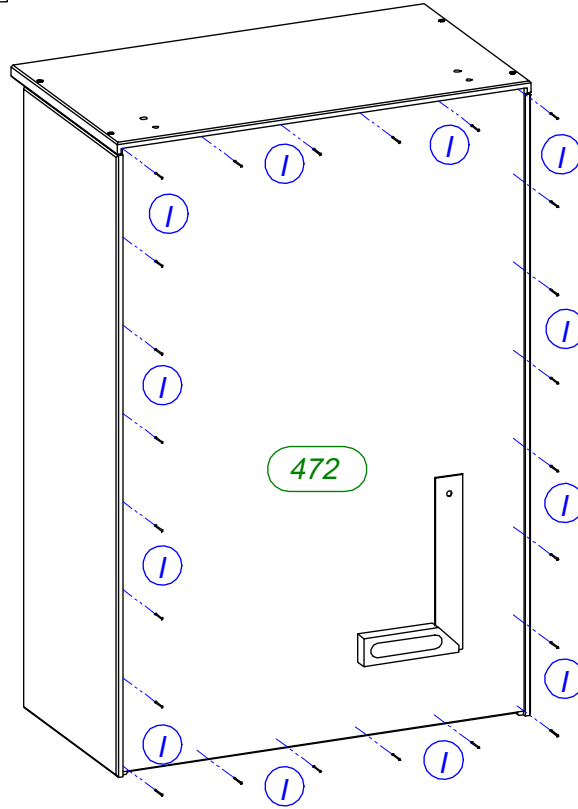
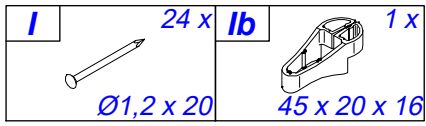

4

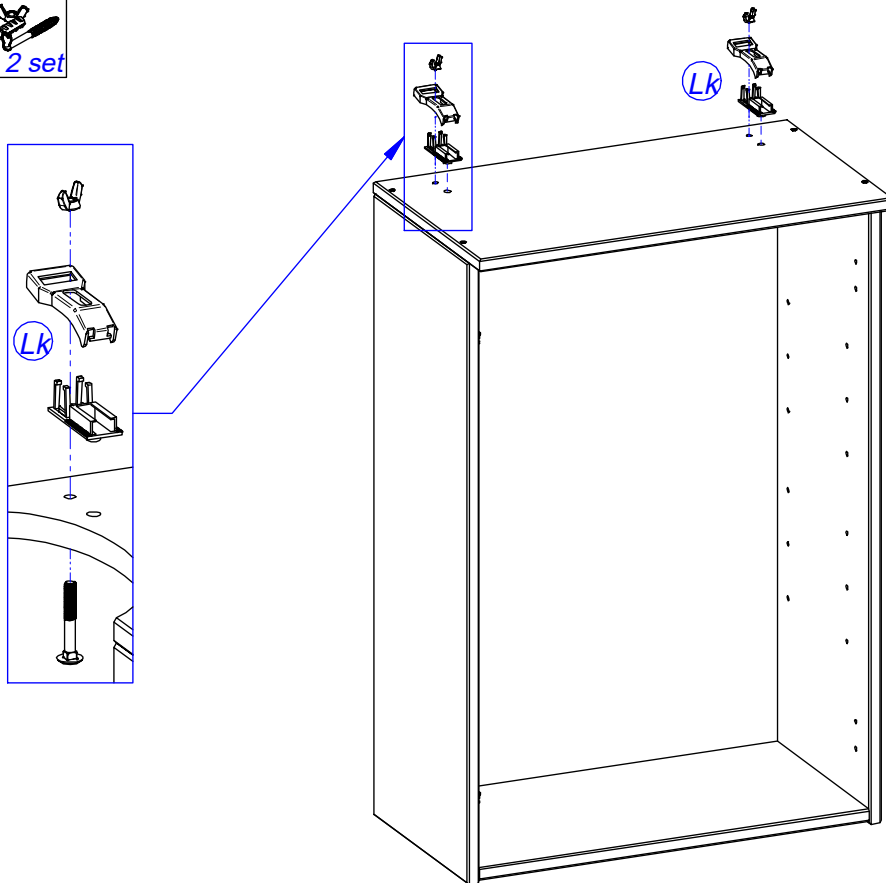
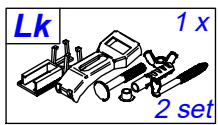

5

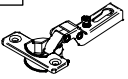

6

Ce	2 x	Dd	1 x	Ea	4 x	No	1 x
							
	fk.9	M4 x 20		Ø3,5 x 15		Ø30x21	

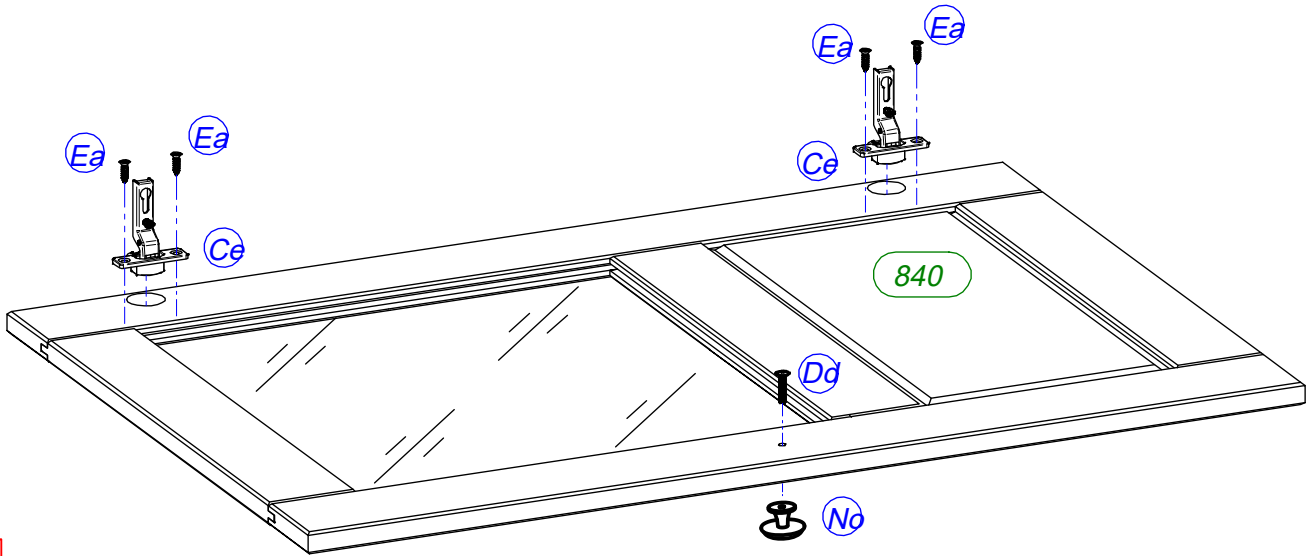

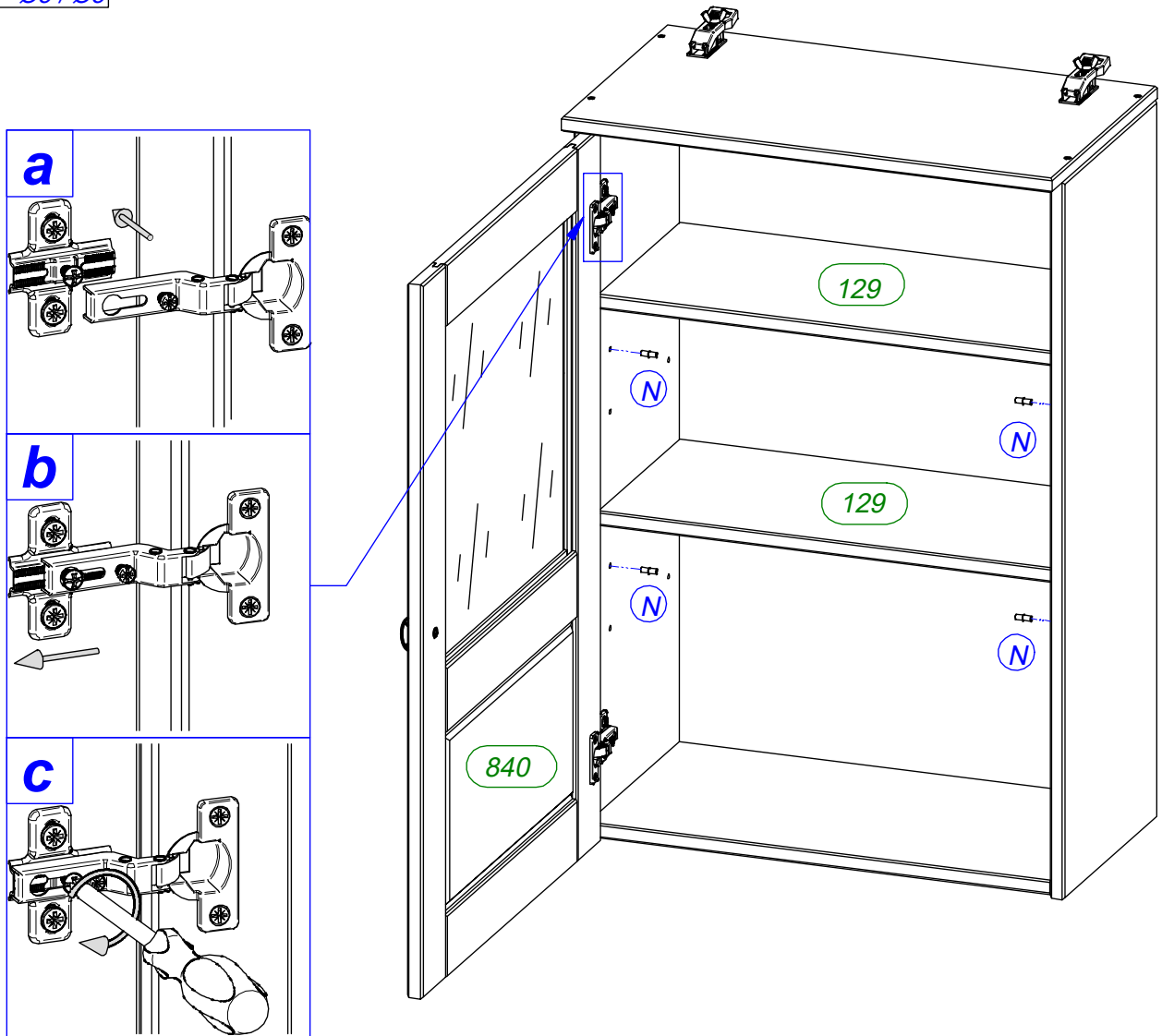

7

N	8 x
	
	Ø5 / Ø5



8

 Achtung • Attention • Attenzione • Opgelet • Uwaga • Pozor • Figyelem • Atenție • Dikkat • Вниманіе 	
(D)	Bei einigen Wandtypen kann ein Spezialdübel erforderlich sein!
(GB)	For certain wall types, a special dowel may be necessary!
(NL)	Bij enkele muurtypes is een speciale plug misschien vereist!
(PL)	Do niektórych rodzajów ścian konieczne mogą być specjalne wkręty!
(TR)	Bazı duvar tiplerinde bunun için özel bir dübel gerekli olabilir!
(RU)	Для некоторых типов стен может потребоваться специальный дюбель!
(FR)	Pour certains types de murs il faut des chevilles spéciales !
(IT)	Per alcune strutture di parete può essere necessario un tassello speciale!
(CZ)	U některých typů stěn může být zapotřebí speciální hmoždinka!
(SK)	Pre niektoré druhy stien môže byť potrebná špeciálna hmoždinka!
(HU)	Egyes faltípusoknál speciális tiplit kell használni!
(RO)	Pentru unele tipuri de pereți este posibil să fie necesar un diblu special!

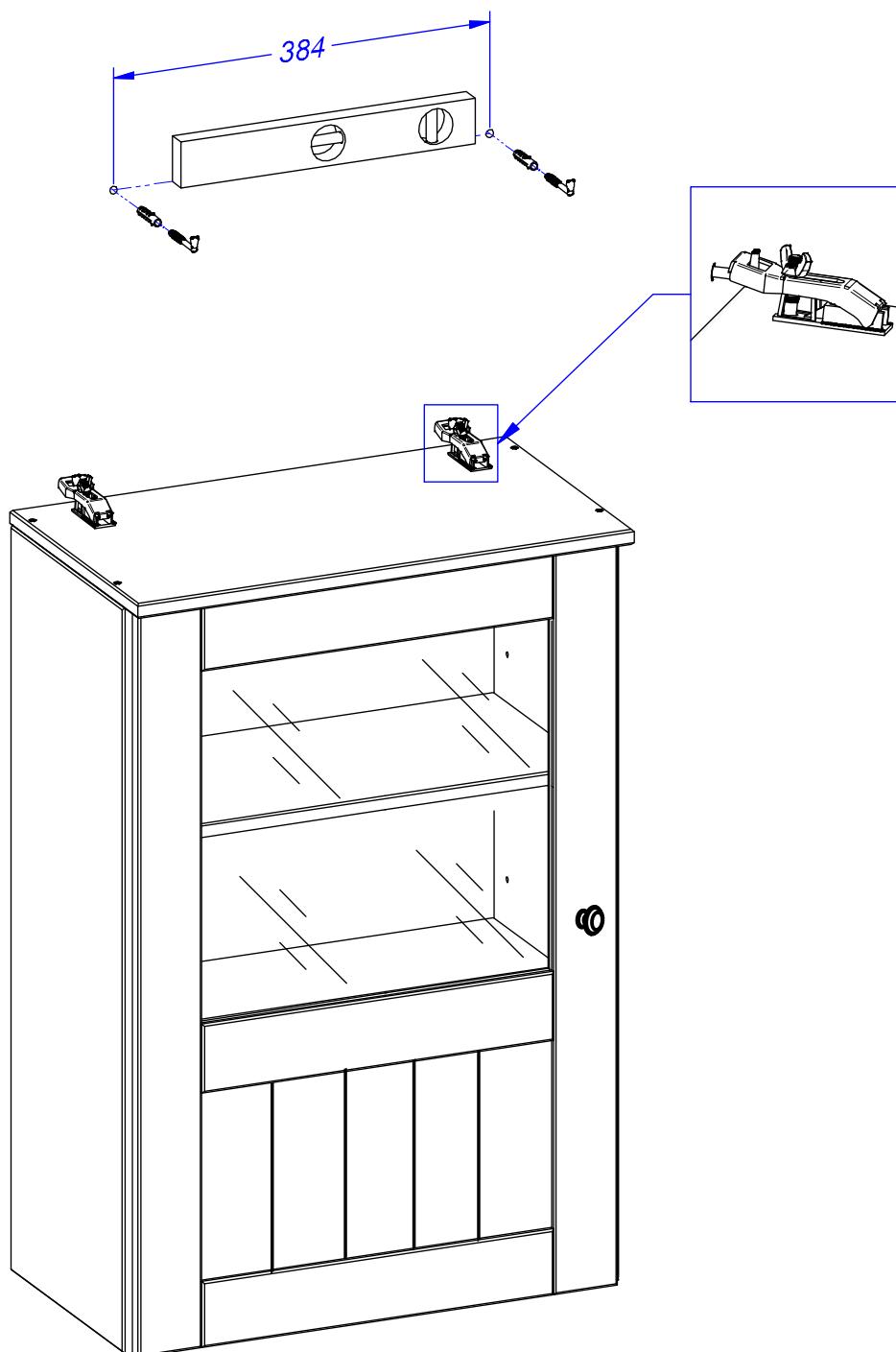



**Achtung • Attention • Attenzione • Opgelet • Uwaga • Pozor • Figyelem • Atenție •
Dikkat • Внимание**



(D)	Türen einstellen (Scharniere justieren)
(GB)	Adjusting the doors (adjusting the hinges)
(NL)	Deuren instellen (scharnieren afstellen)
(PL)	Nastawić drzwi (wyrównać zawiasy)
(TR)	Kapıların ayarlanması (menteşelerin seviye ayarı)
(RU)	Регулировка дверей (регулировка шарнира)
(FR)	Régler les portes (ajuster les charnières)
(IT)	Sistemare le porte (regolare le cerniere)
(CZ)	Vyrovnejte dvířka (seřďte závěsy)
(SK)	Nastavenie dverí (nastavenie závesov)
(HU)	Állítsa be az ajtókat (állítsa be a zsanérokat)
(RO)	Reglare ușii (ajustare balamale)

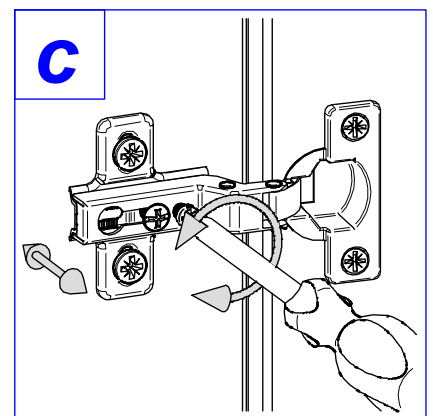
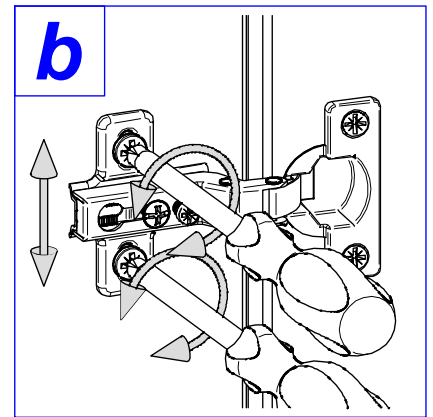
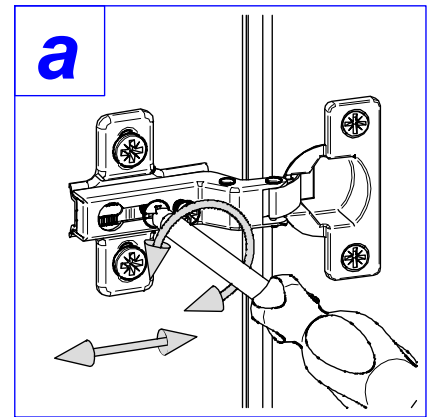
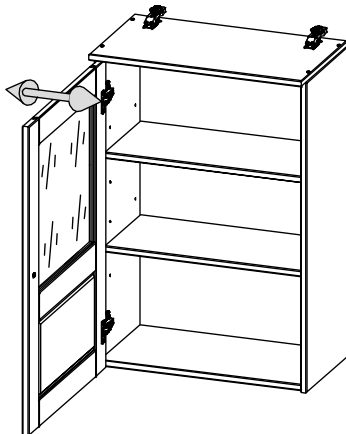
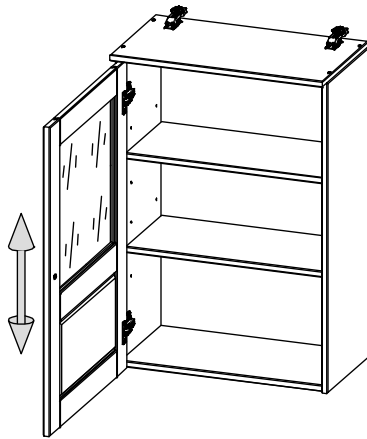
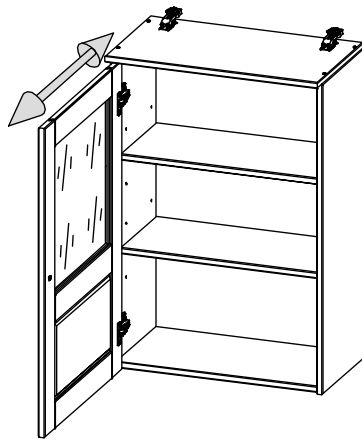

»1360«

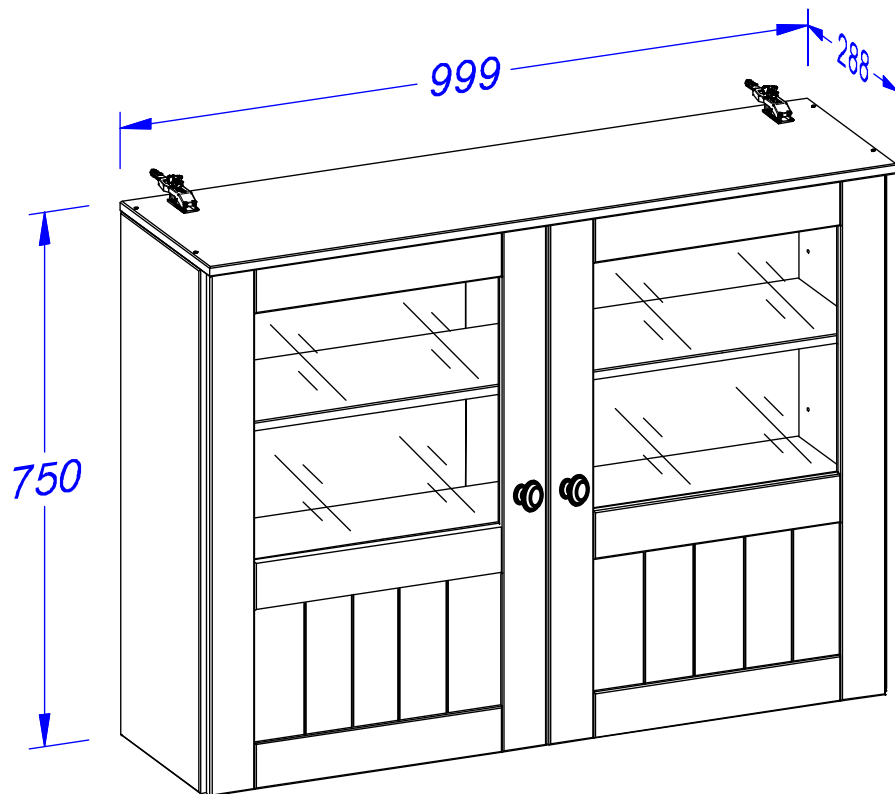

(D) *Montageanleitung*

(NL) *Handleiding voor de montage*

(TR) *Montaj talimatı*

(FR) *Notice de montage*

(CZ) *Montážní návod*

(HU) *Szerelési útmutató*

(GB) *Assembly instructions*

(PL) *Instrukcja montażu*

(RU) *Инструкция по монтажу*

(IT) *Istruzioni di montaggio*

(SK) *Návod na montáž*

(RO) *Instrucțiuni de montaj*

Service • Dienstverlening • Serwis • Servis • Сервисная служба • Assistenza • Szerviz

Name • Nom • Nome • Naam • Nazwa • Jméno •
Názov • Név • Denumire • Isim • Название

Nr. • No. • N° • Номер • Č • Sz

Typ • Type • Tip • Tipus • Тiпо • Тип

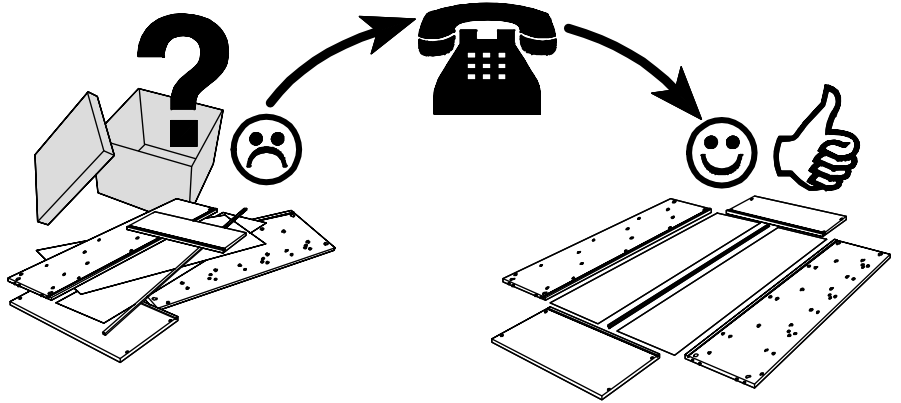
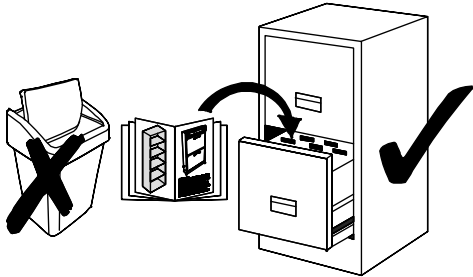

A	8 x	C	4 x	Ce	4 x	Dd	2 x	Ea	8 x	Fb	1 x
Ø8 x 35		2 mm		fk.9		M4 x 20		Ø3,5 x 15		3 mm	
G	4 x	Ga	4 x	Hc	4 x	I	50 x	lb	1 x	Lk	1 x
L - 34		Ø15 x 11		Ø5 x 50		Ø1,2 x 20		45 x 20 x 16		2 set	
N	8 x	No	2 x								
Ø5 / Ø5		Ø30x21									

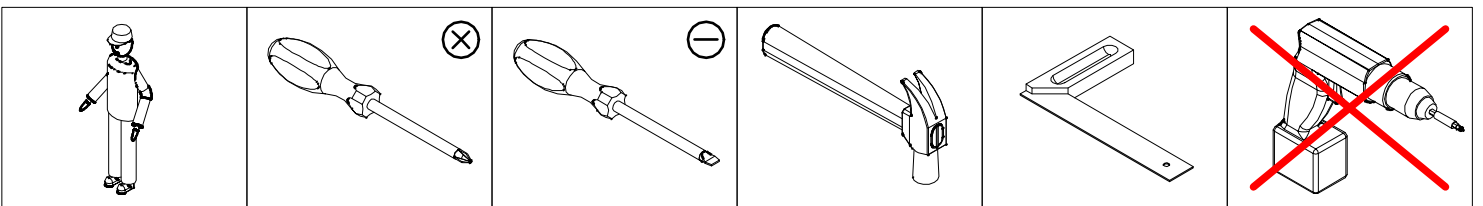

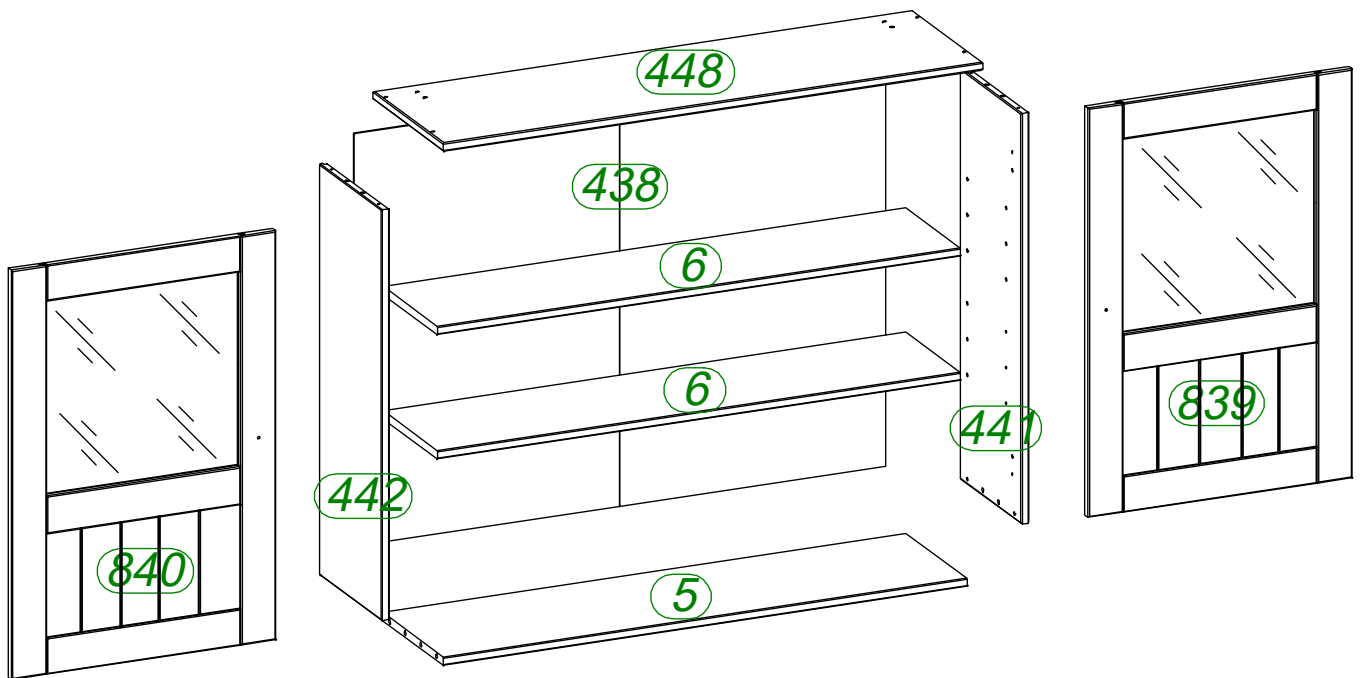

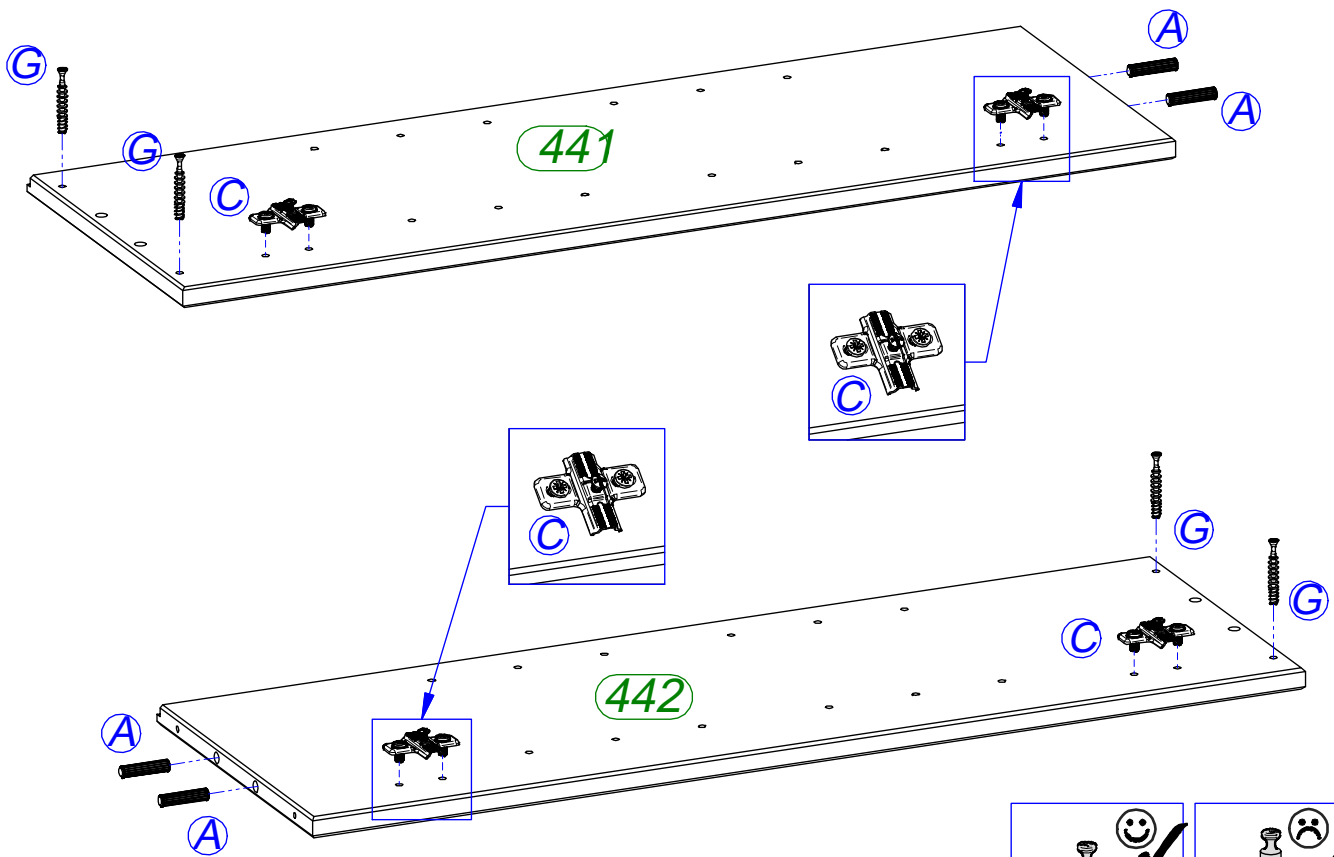
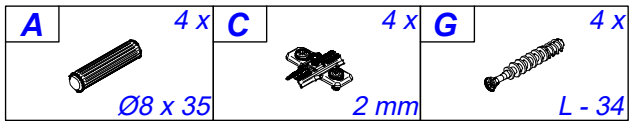
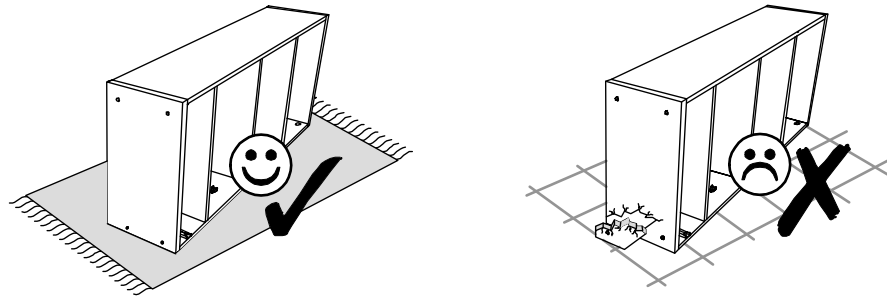

1

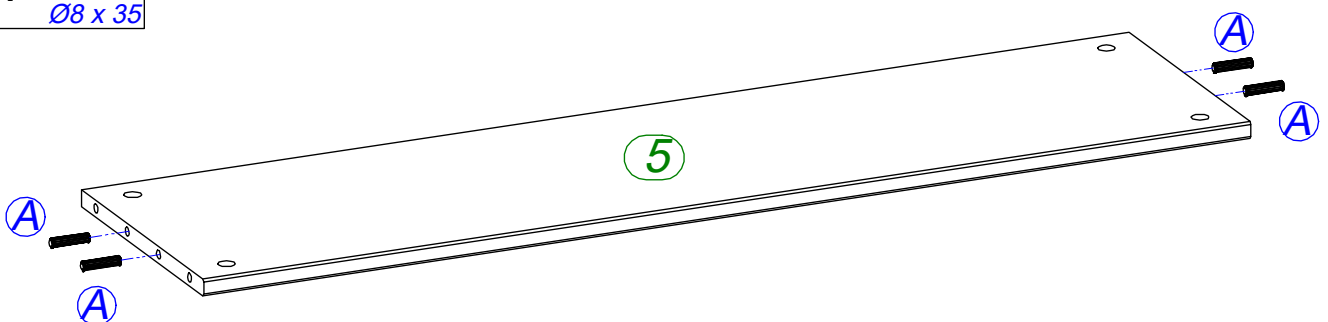
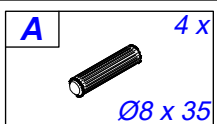

2

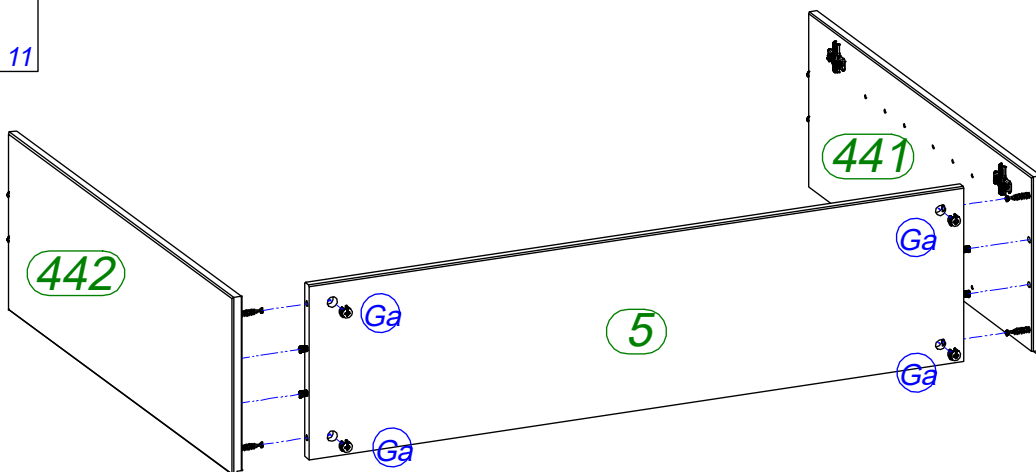
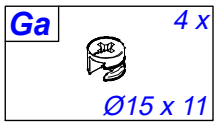

3

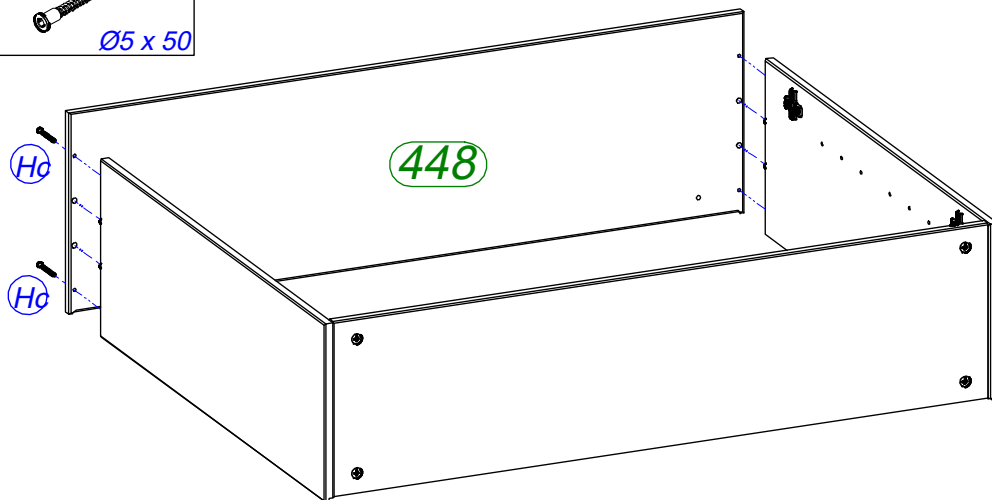
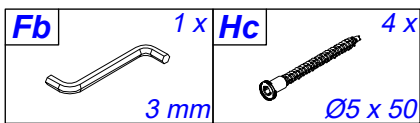

4

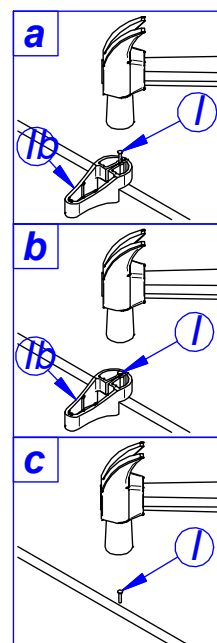
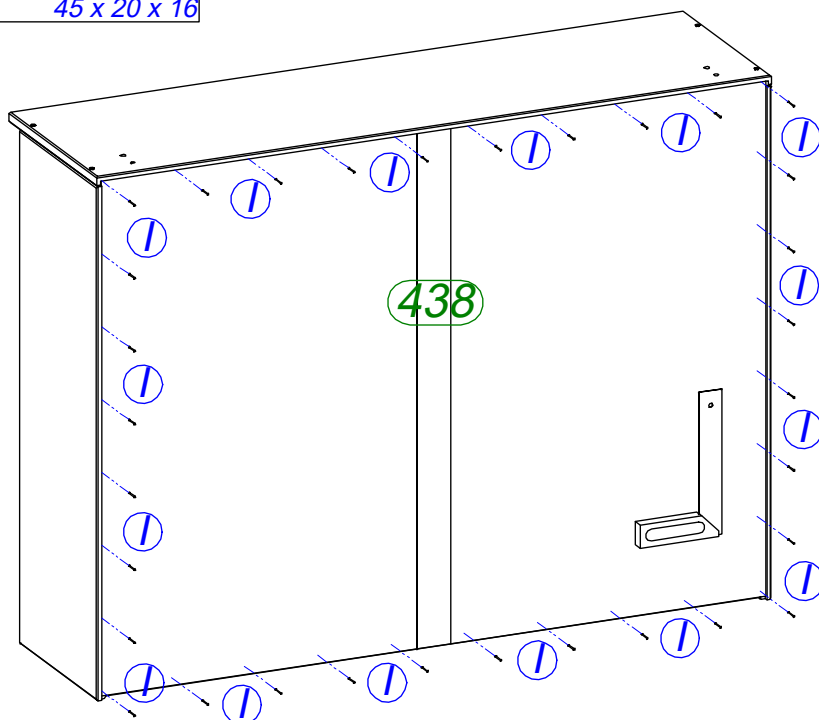
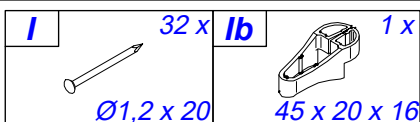

5

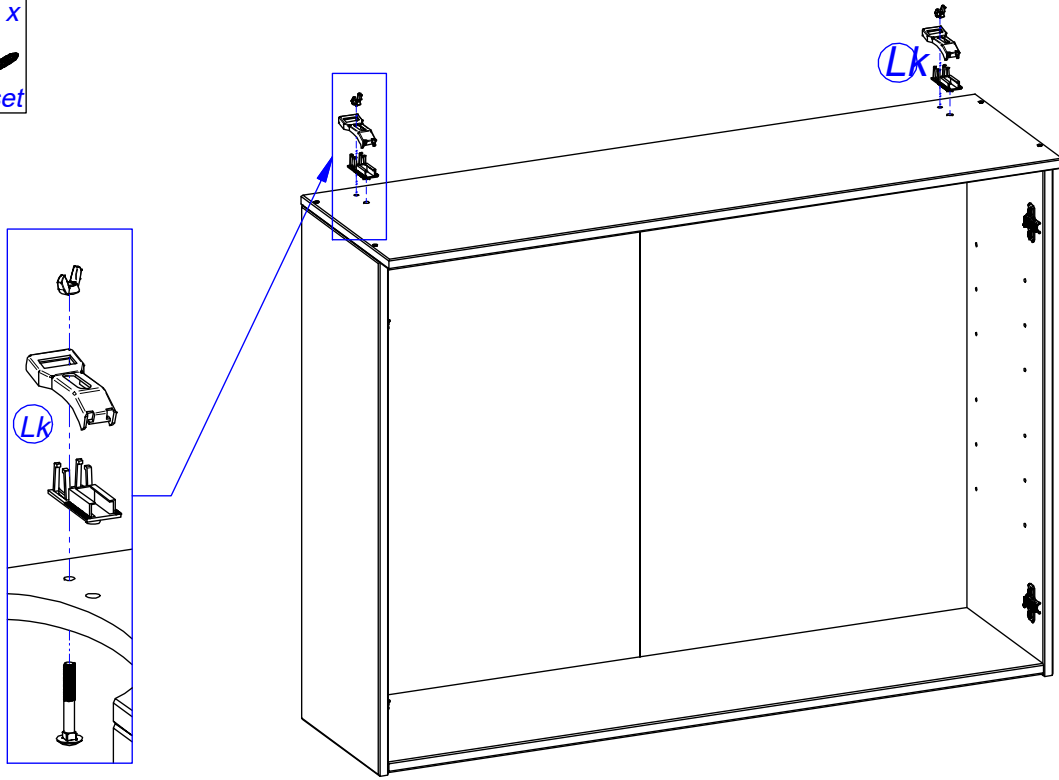
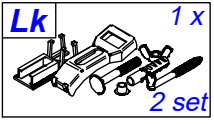

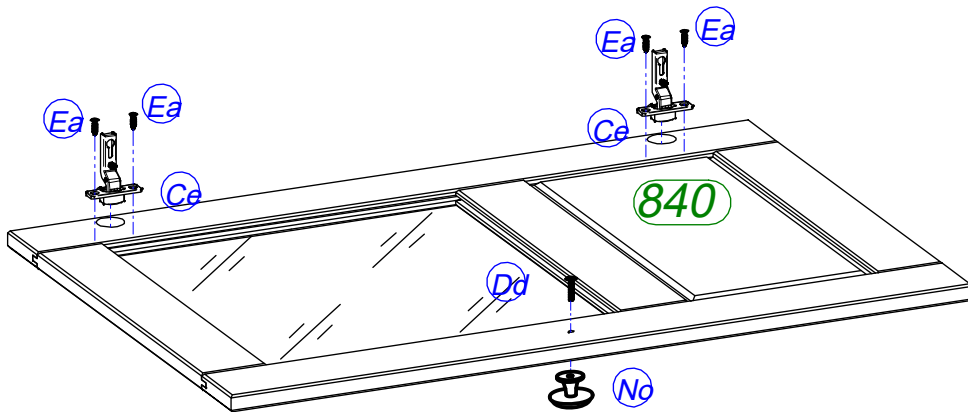
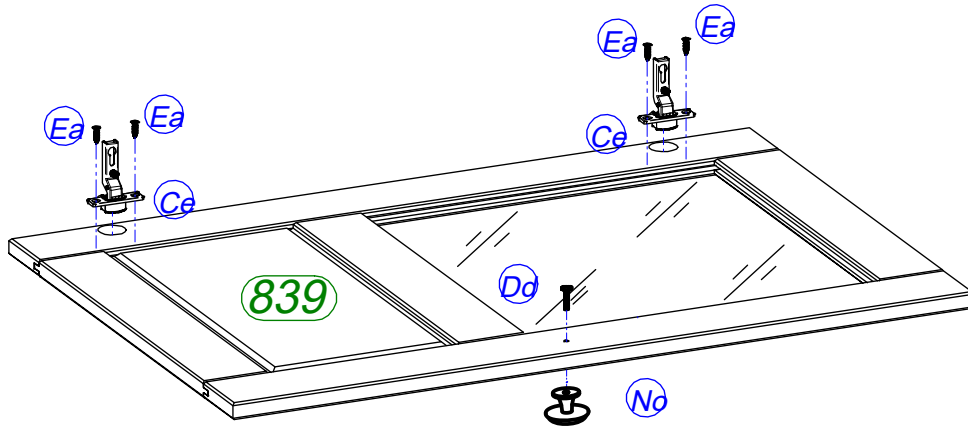
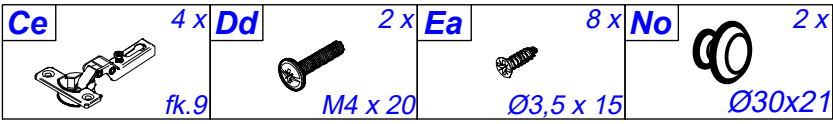

6



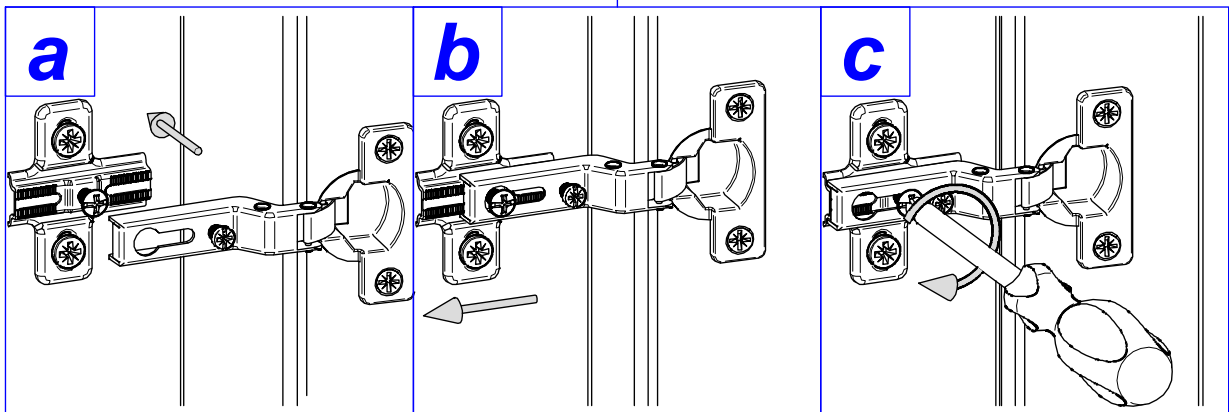
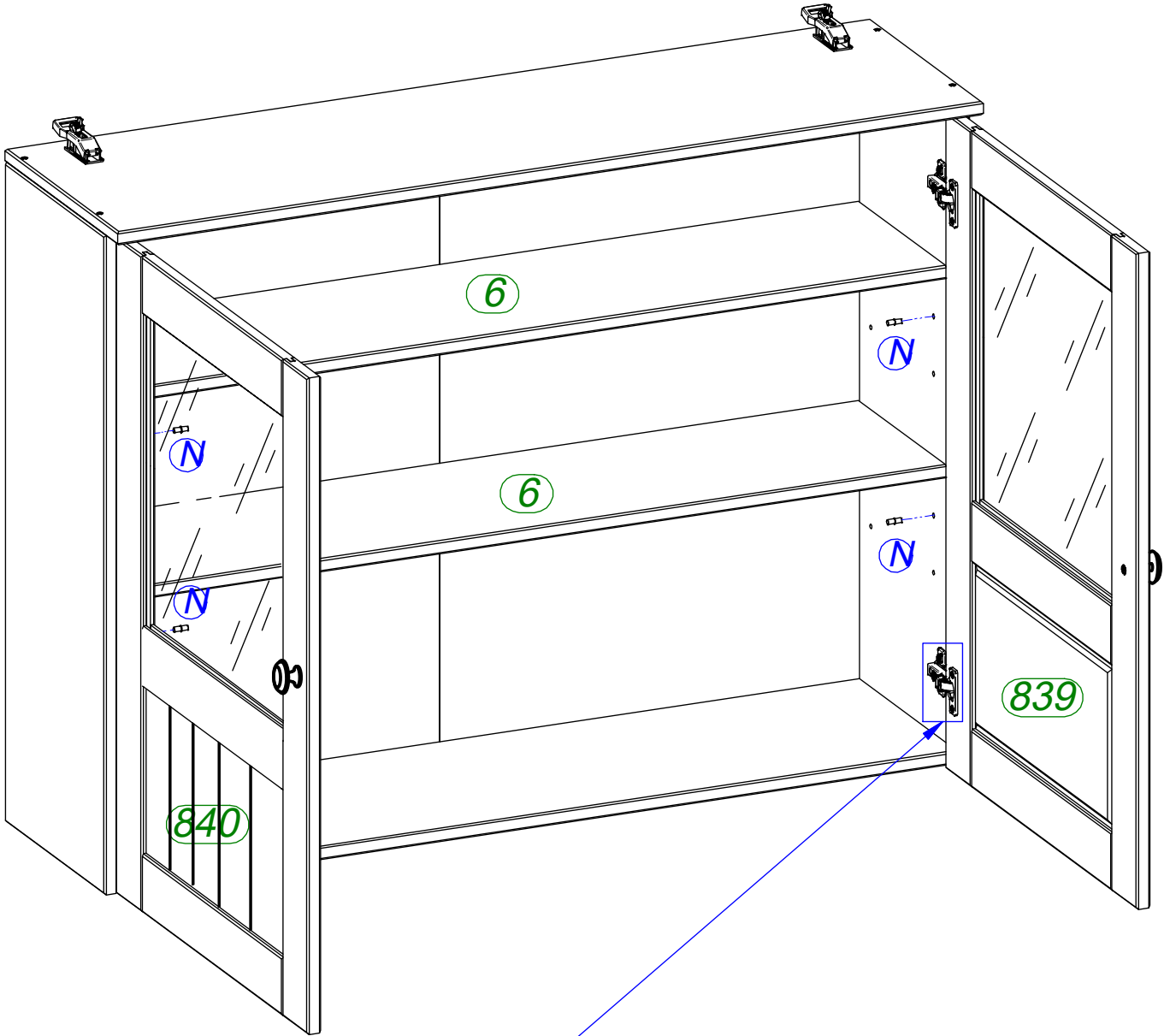
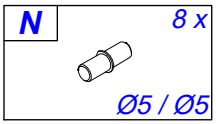

7

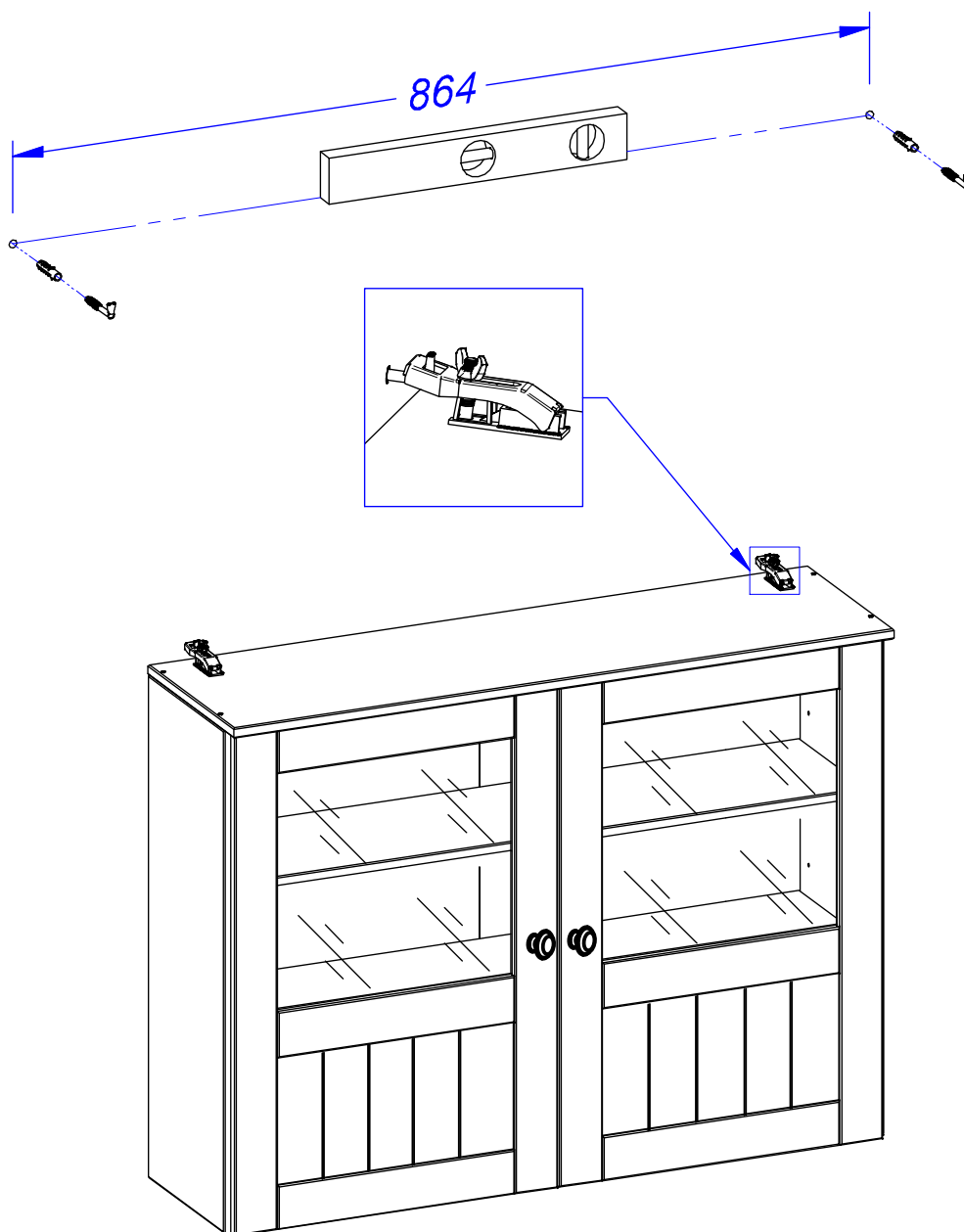

8

 Achtung • Attention • Attenzione • Opgelet • Uwaga • Pozor • Figyelem • Atenție • Dikkat • Внимание 	
(D)	Bei einigen Wandtypen kann ein Spezialdübel erforderlich sein!
(GB)	For certain wall types, a special dowel may be necessary!
(NL)	Bij enkele muurtypes is een speciale plug misschien vereist!
(PL)	Do niektórych rodzajów ścian konieczne mogą być specjalne wkręty!
(TR)	Bazı duvar tiplerinde bunun için özel bir dübel gerekli olabilir!
(RU)	Для некоторых типов стен может потребоваться специальный дюбель!
(FR)	Pour certains types de murs il faut des chevilles spéciales !
(IT)	Per alcune strutture di parete può essere necessario un tassello speciale!
(CZ)	U některých typů stěn může být zapotřebí speciální hmoždinka!
(SK)	Pre niektoré druhy stien môže byť potrebná špeciálna hmoždinka!
(HU)	Egyes faltípusoknál speciális tiplít kell használni!
(RO)	Pentru unele tipuri de pereți este posibil să fie necesar un diblu special!



 Achtung • Attention • Attenzione • Opgelet • Uwaga • Pozor • Figyelem • Atenție • Dikkat • Вниманіе 	
(D)	Türen einstellen (Scharniere justieren)
(GB)	Adjusting the doors (adjusting the hinges)
(NL)	Deuren instellen (scharnieren afstellen)
(PL)	Nastawić drzwi (wyrównać zawiasy)
(TR)	Kapıların ayarlanması (menteşelerin seviye ayarı)
(RU)	Регулировка дверей (регулировка шарнира)
(FR)	Régler les portes (ajuster les charnières)
(IT)	Sistemare le porte (regolare le cerniere)
(CZ)	Vyrovnejte dvířka (seříd'te závěsy)
(SK)	Nastavenie dverí (nastavenie závesov)
(HU)	Állítsa be az ajtókat (állítsa be a zsanérokat)
(RO)	Reglare ușii (ajustare balamale)

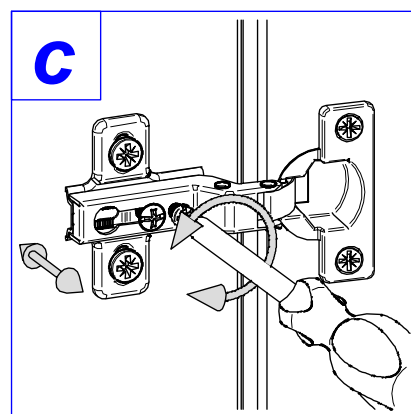
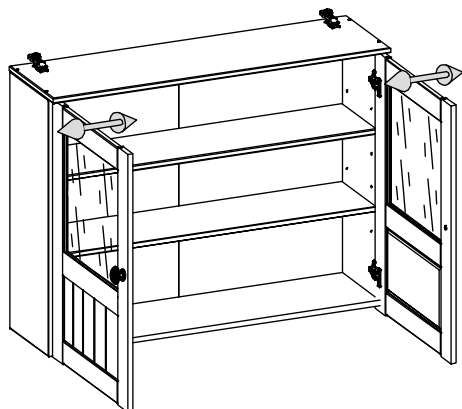
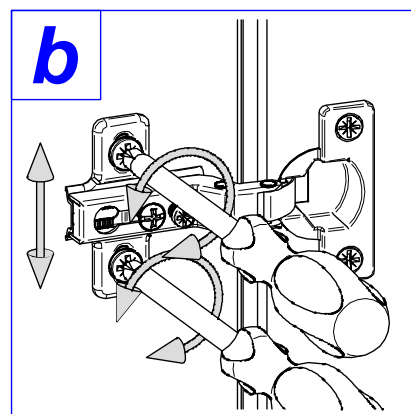
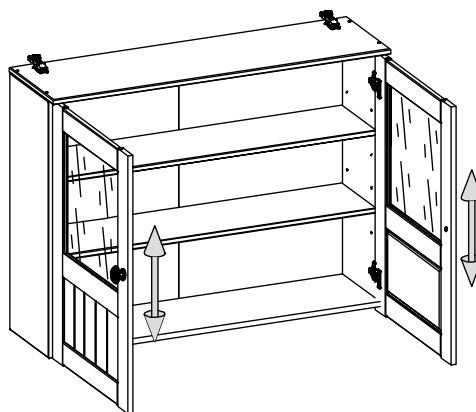
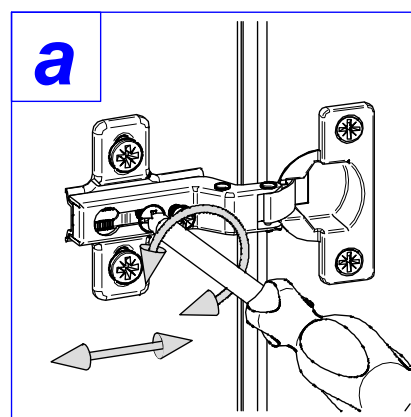
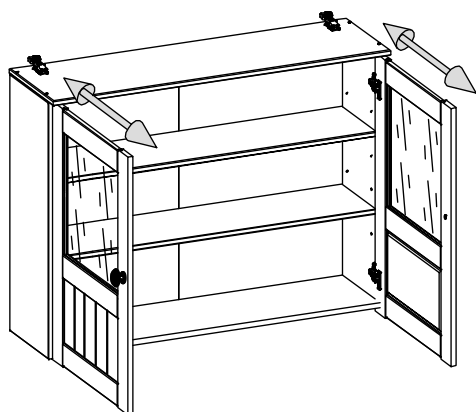

»1366«

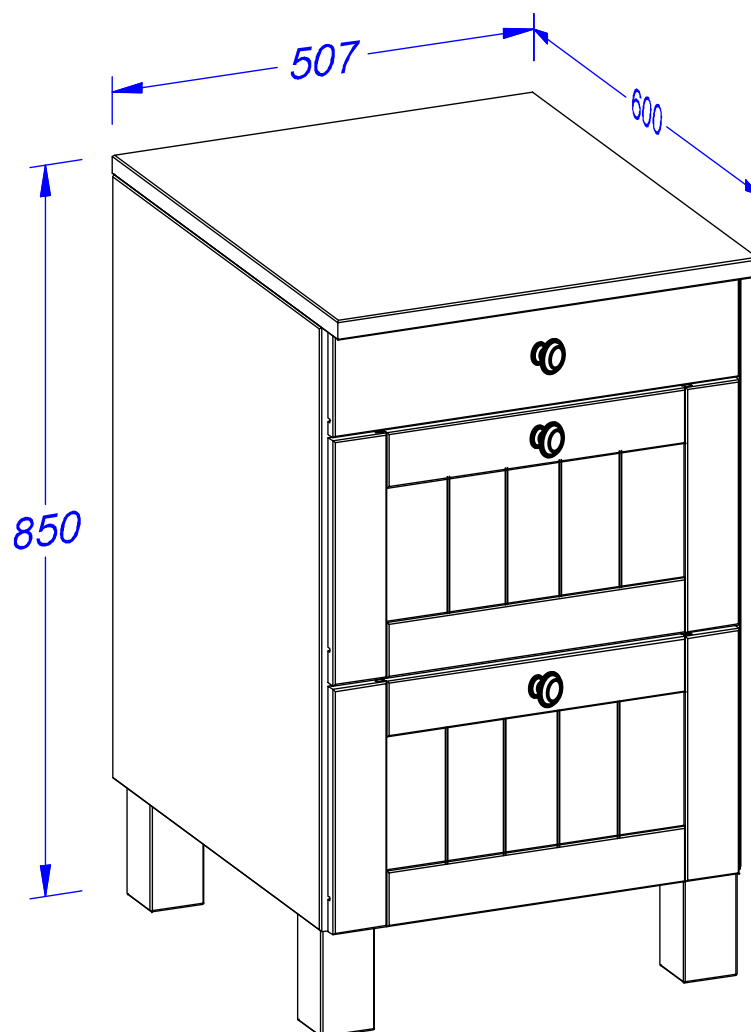

(D) *Montageanleitung*

(NL) *Handleiding voor de montage*

(TR) *Montaj talimatı*

(FR) *Notice de montage*

(CZ) *Montážní návod*

(HU) *Szerelési útmutató*

(GB) *Assembly instructions*

(PL) *Instrukcja montażu*

(RU) *Инструкция по монтажу*

(IT) *Istruzioni di montaggio*

(SK) *Návod na montáž*

(RO) *Instrucțiuni de montaj*









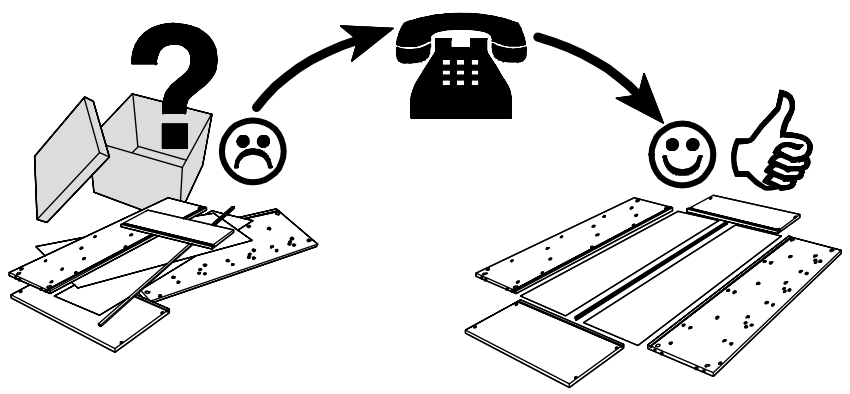
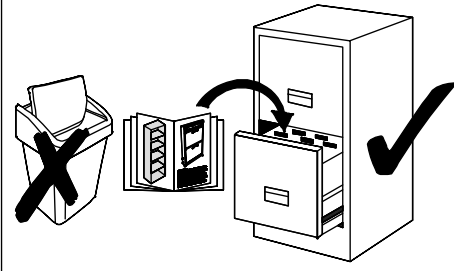

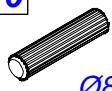

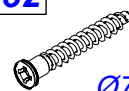

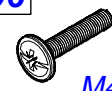
Service • Dienstverlening • Serwis • Servis • Сервисная служба • Assistenza • Szerviz

Name • Nom • Nome • Naam • Nazwa • Jméno •
Názov • Név • Denumire • Isim • Название

Nr. • No. • N° • Номер • Č • Sz

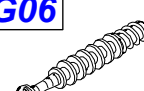
Typ • Type • Tip • Tipus • Тиро • Тип

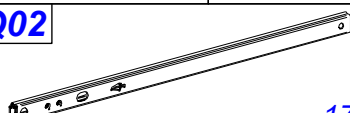
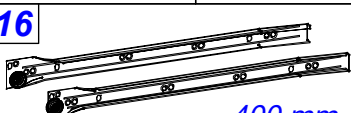

A10 22 x  Ø8 x 35	B01 18 x  Ø5,8 x 8	B52 4 x  Ø7 x 50	D02 2 x  M4 x 10	D06 3 x  M4 x 20	E17 12 x  Ø3,5 x 15
E22 16 x  Ø3,5 x 35	F04 1 x  4 mm	F08 1 x  45 x 20 x 16	G02 20 x  Ø15 x 11	G06 20 x  L - 34	I01 25 x  Ø1,2 x 20
P23 3 x  Ø30x21	Q02 2 x  17 x 430		Q16 2 x  400 mm, L + R		
Q17 2 x  400 mm, L + R					

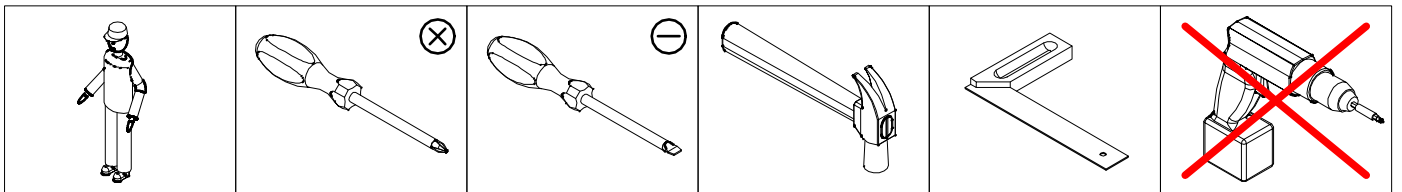

0 10 20 30 40 50 60 70 80 90 100 110 120 130 140 150 160 170 180 190

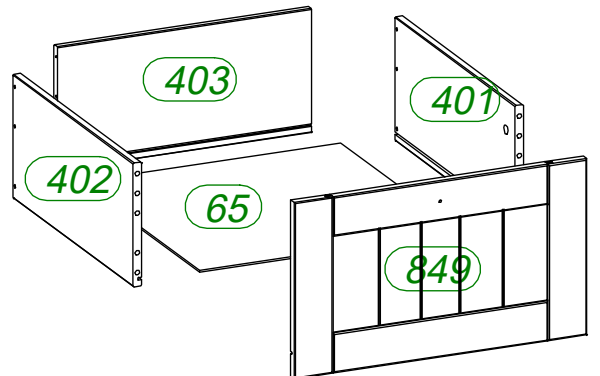
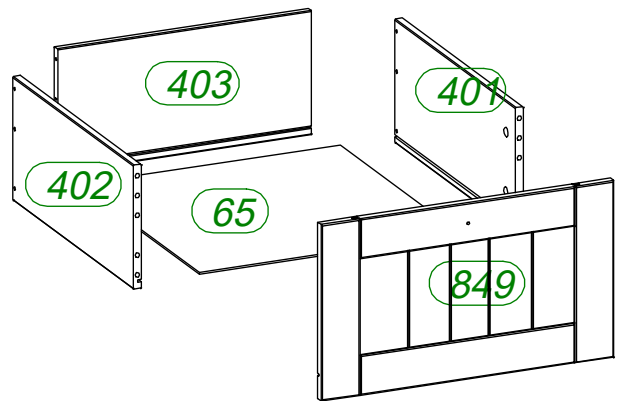
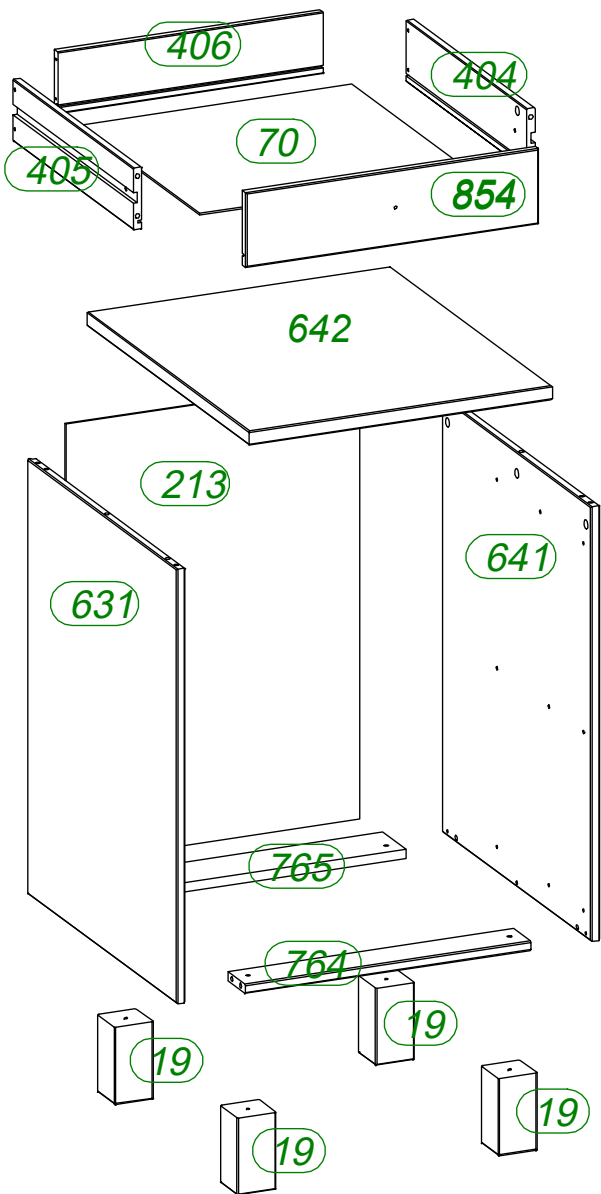



Achtung • Attention • Attenzione • Opgelet • Uwaga • Pozor • Figyelem • Atenție •
Dikkat • Внимание

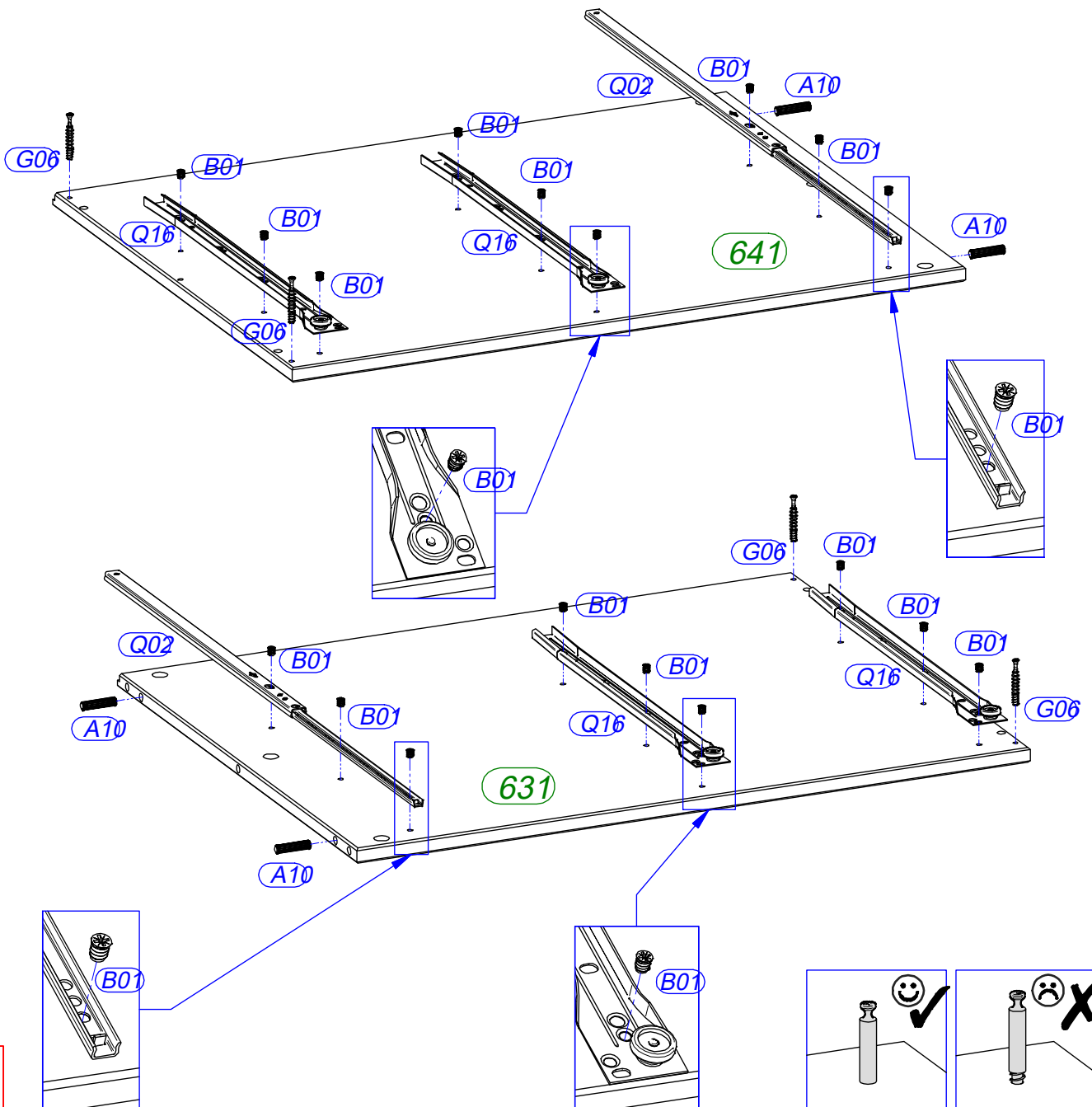
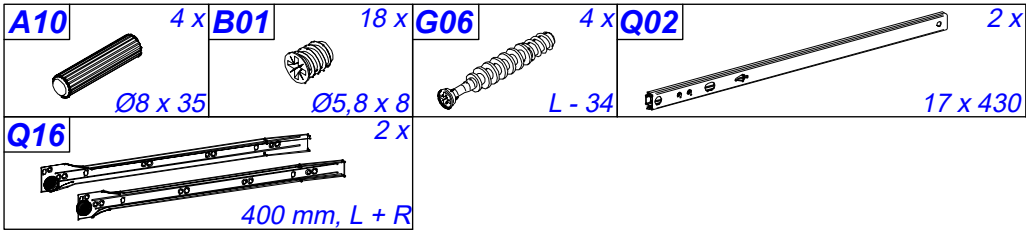
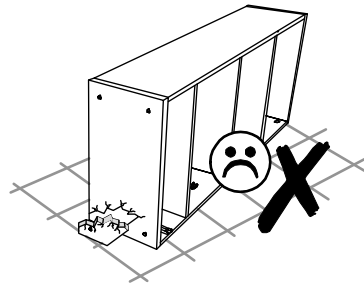
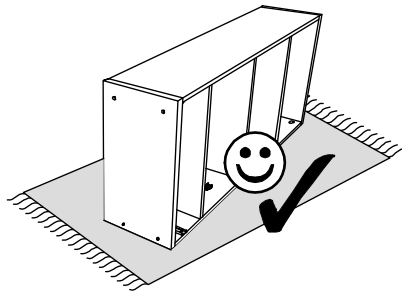

1

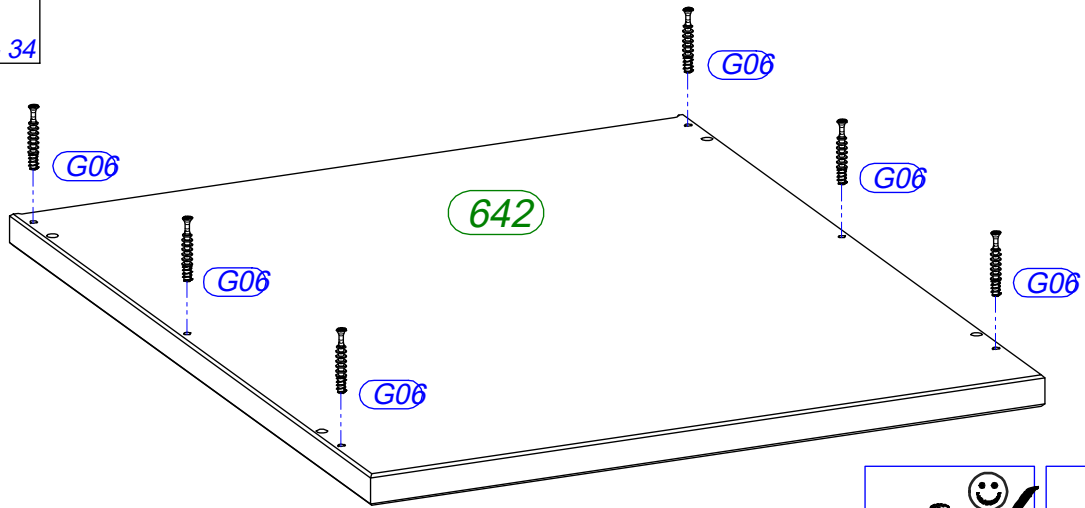
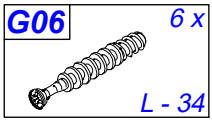

2

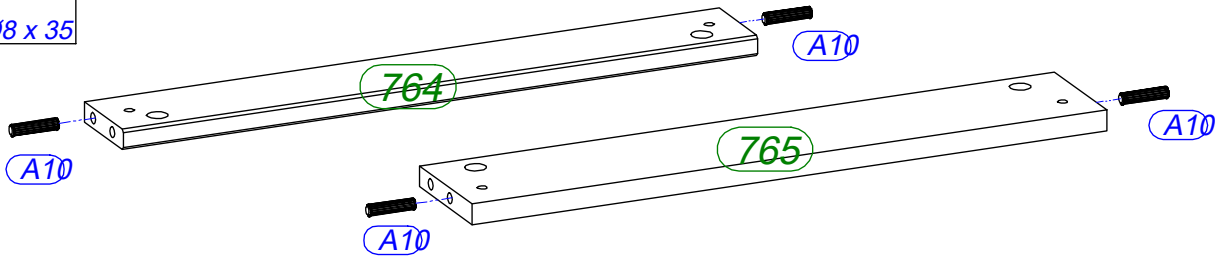
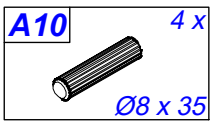
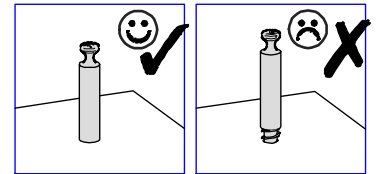

3

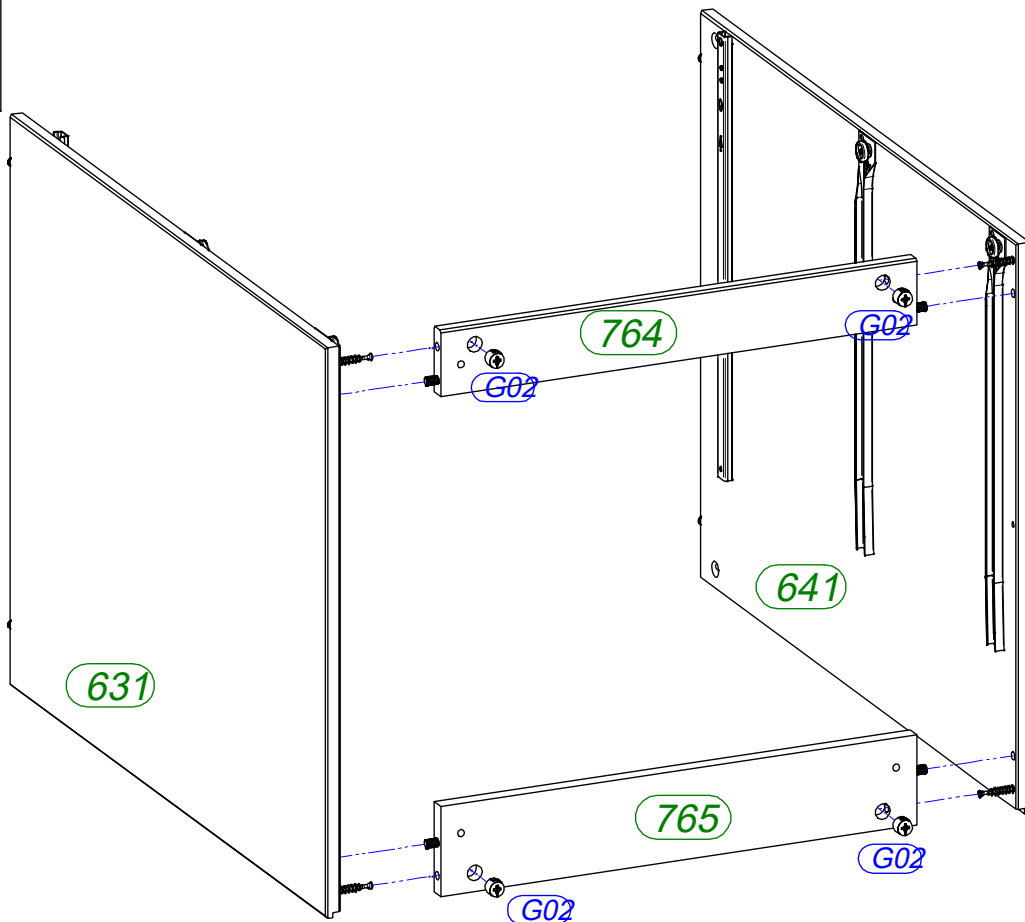
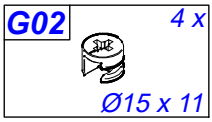

4

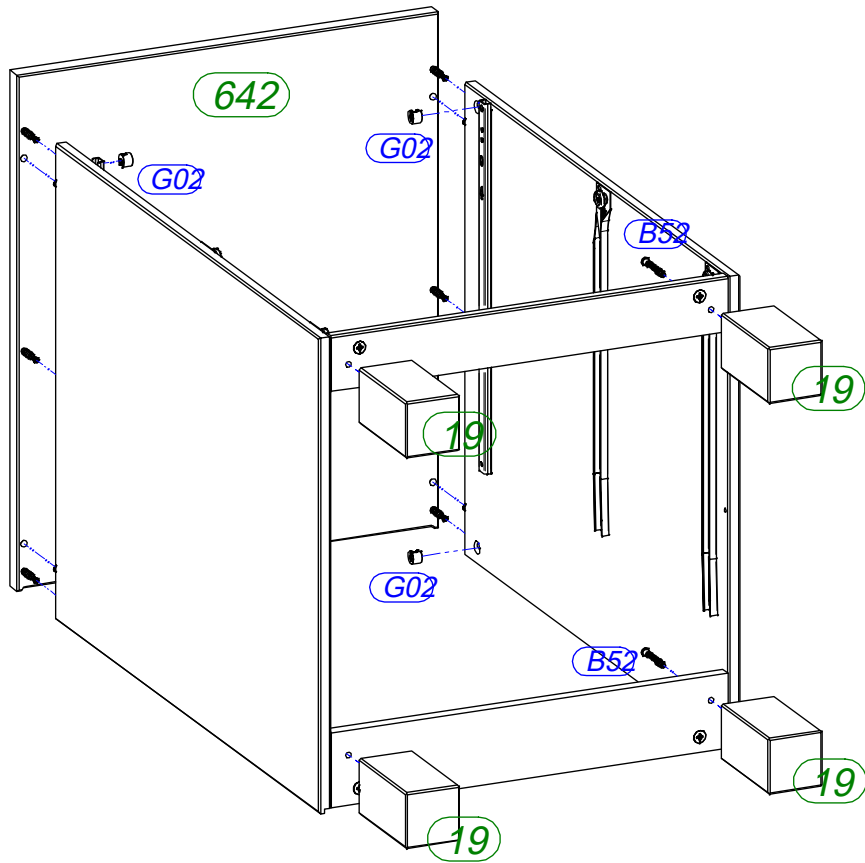
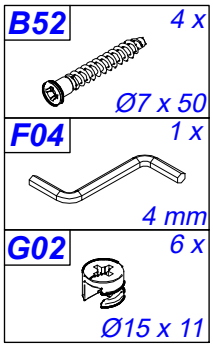

5

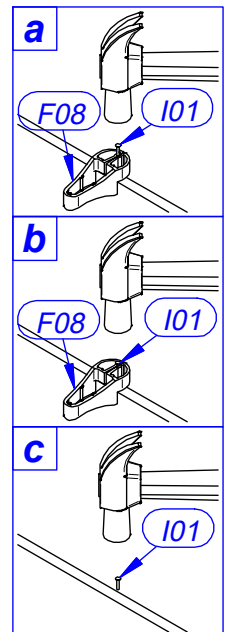
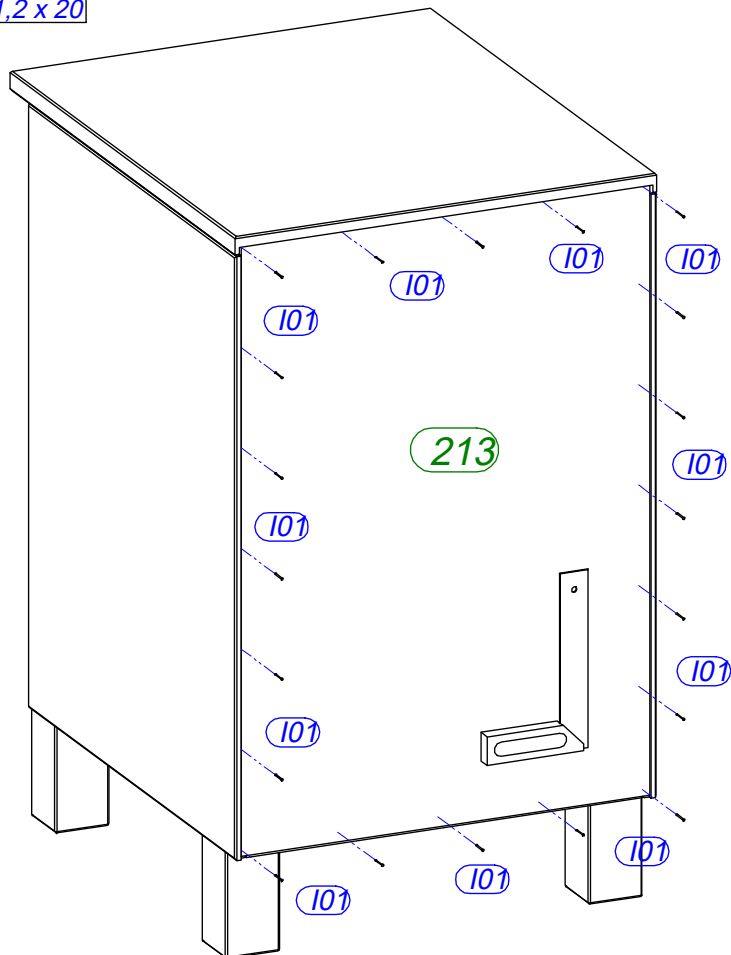
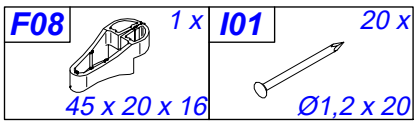

6

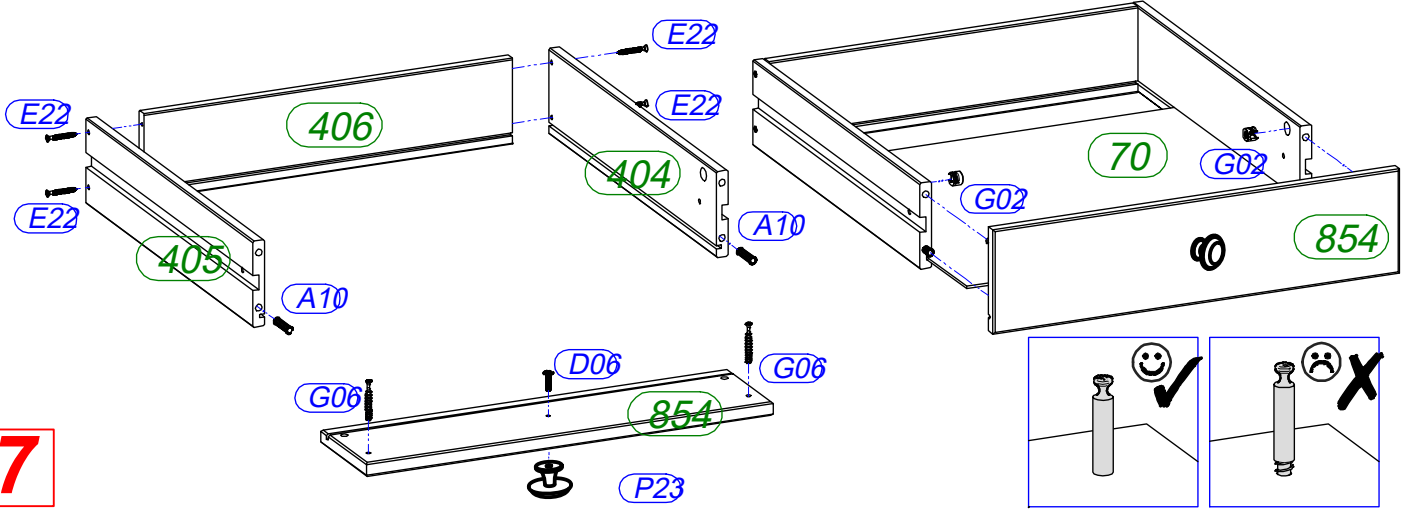
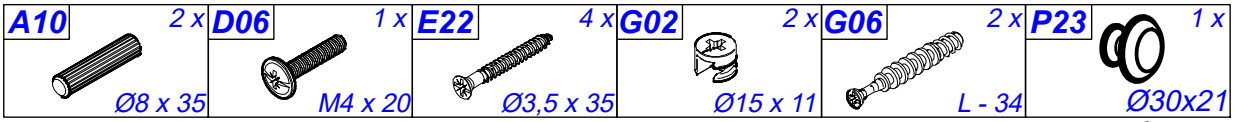

7

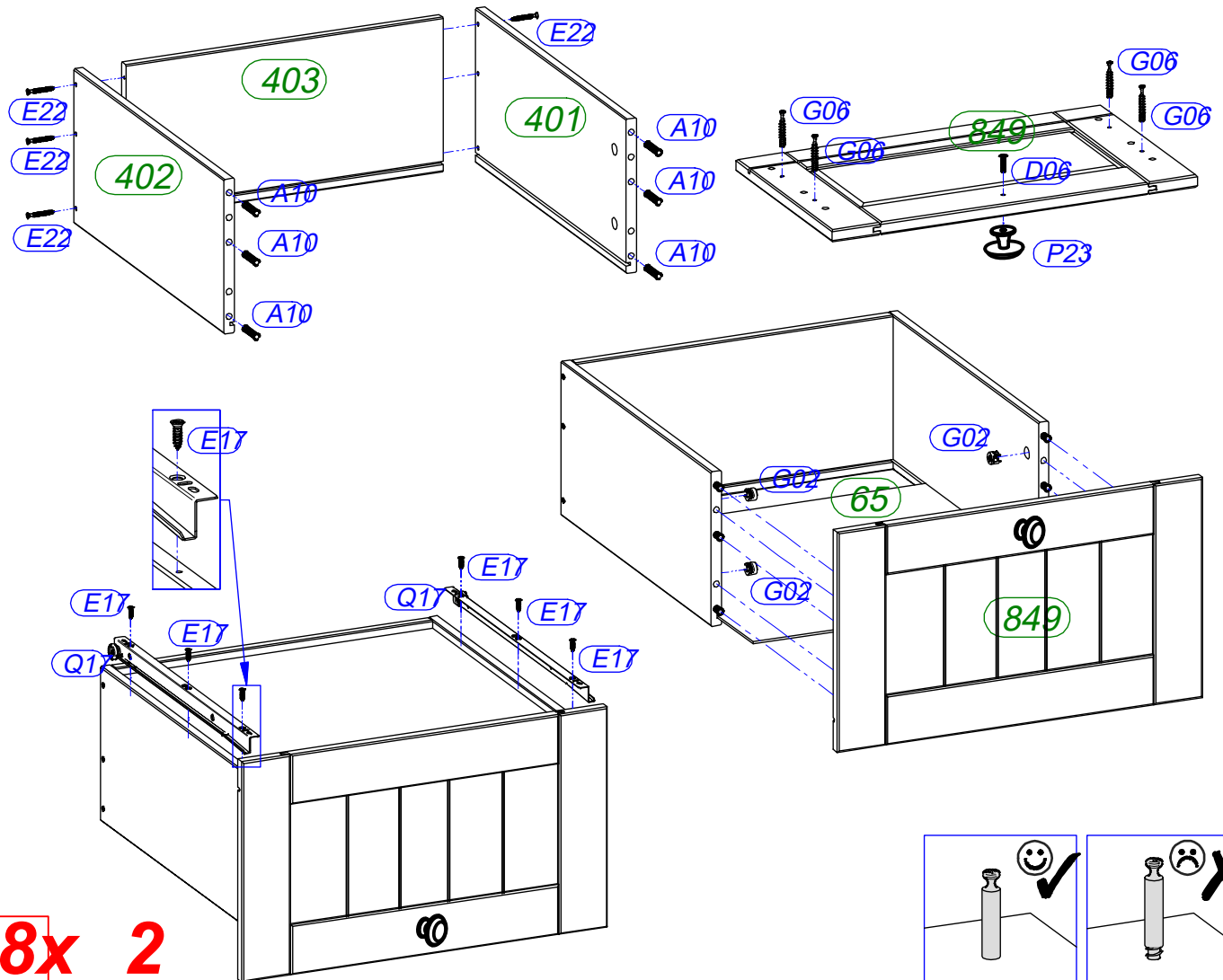
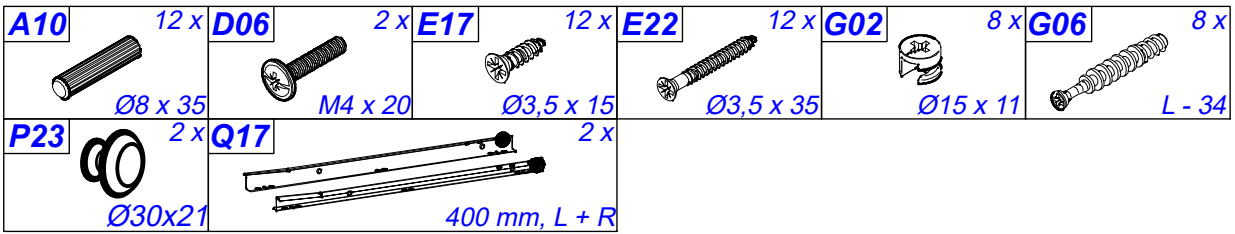

8x 2

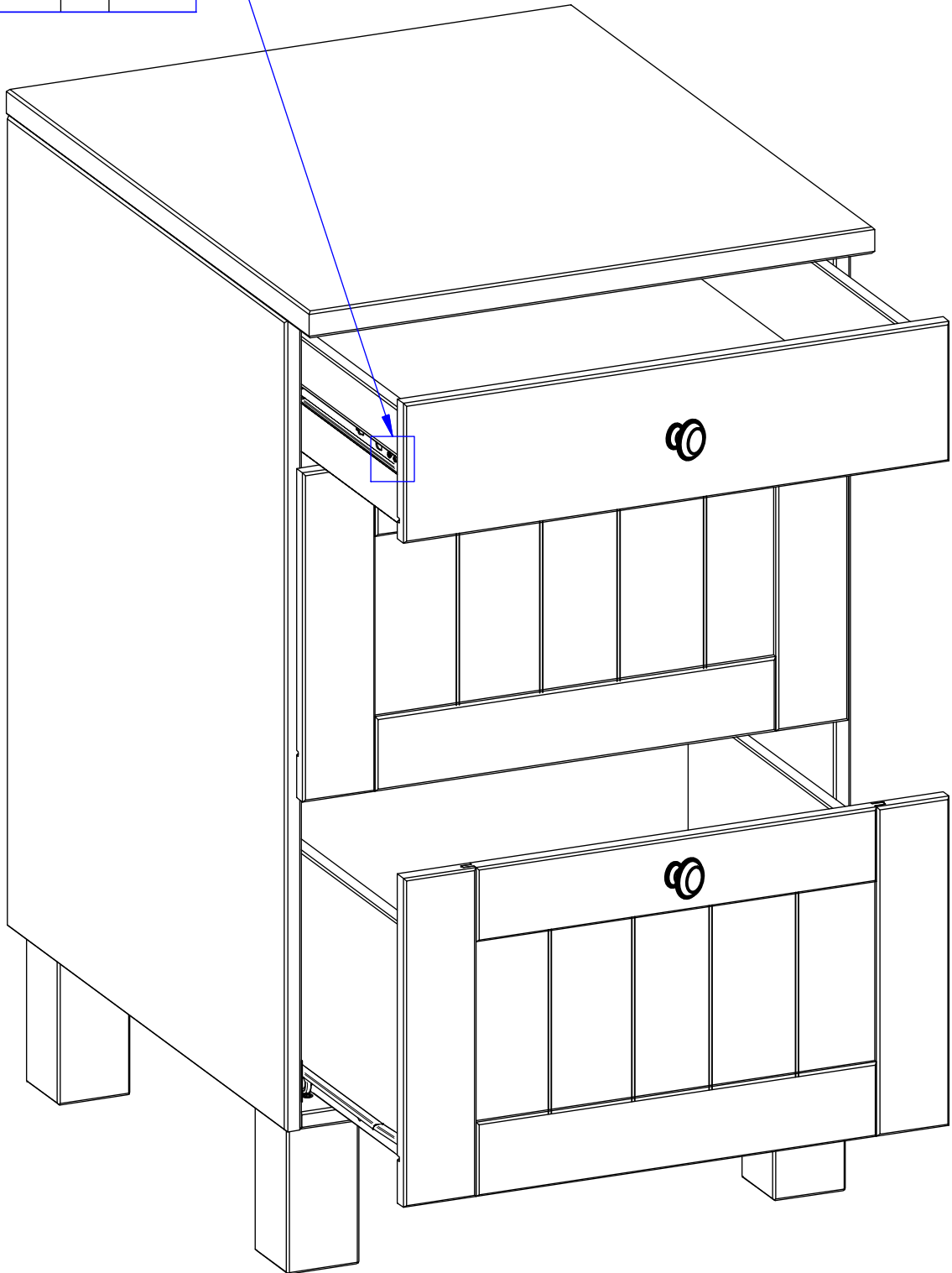
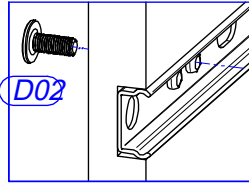
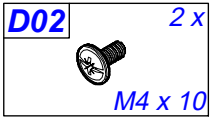

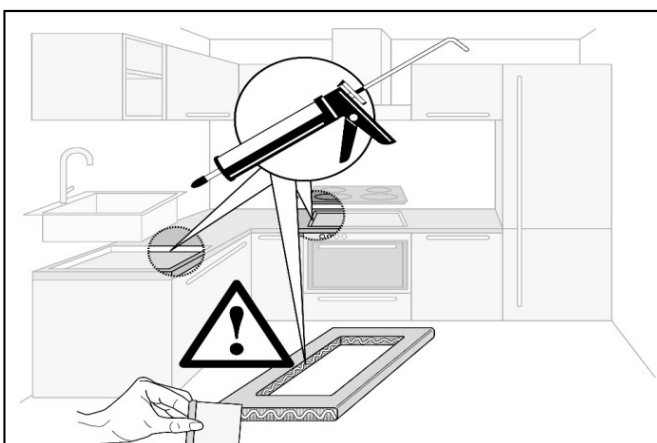
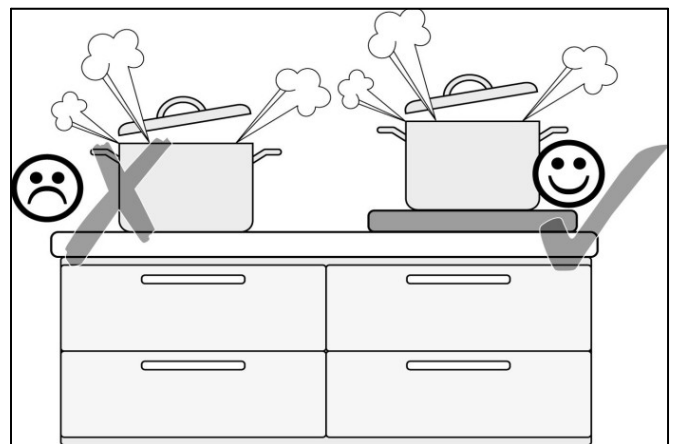
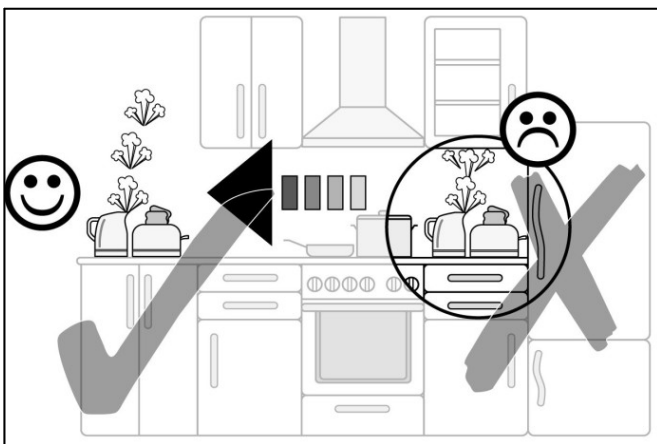
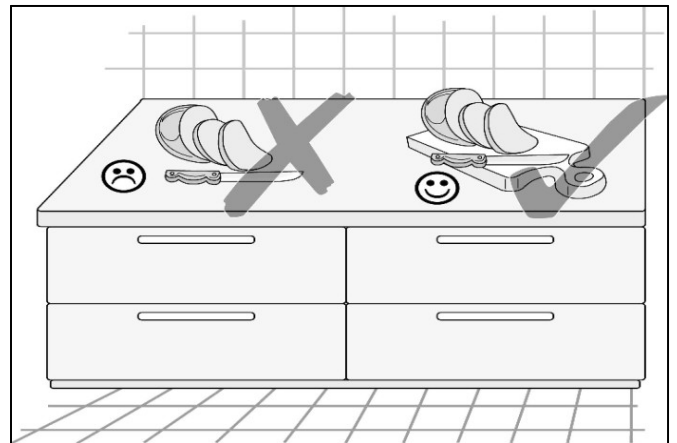
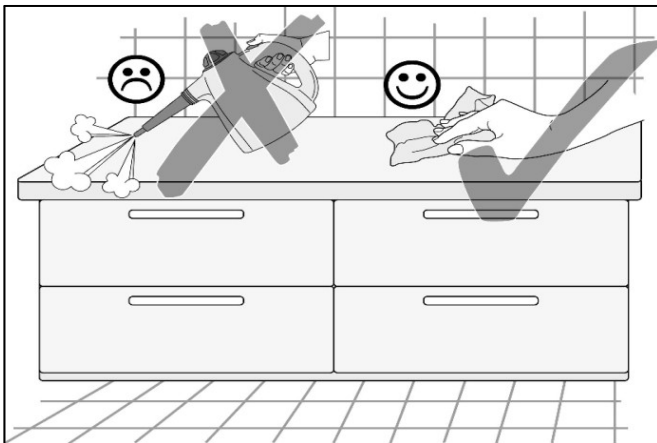
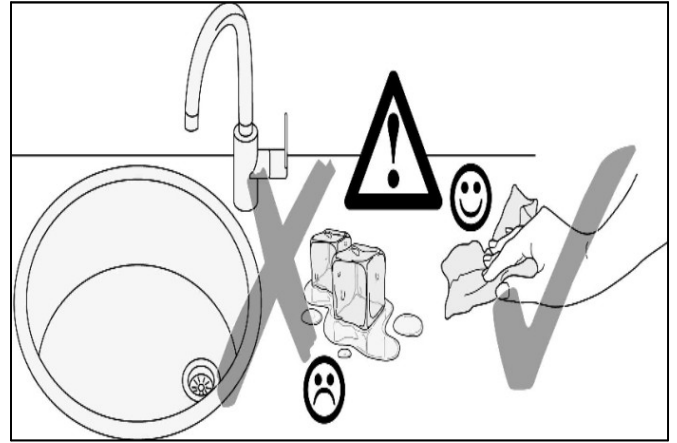
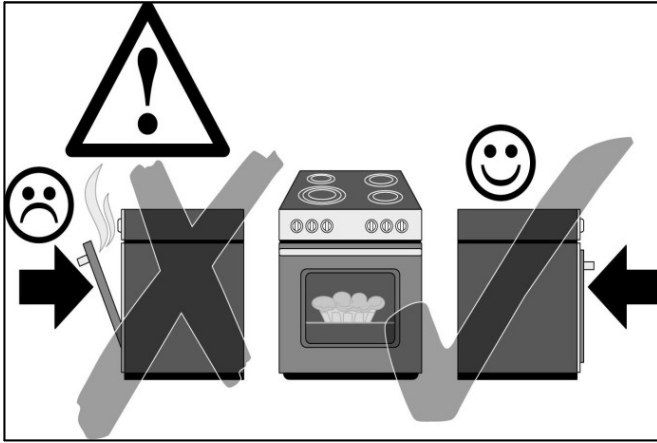

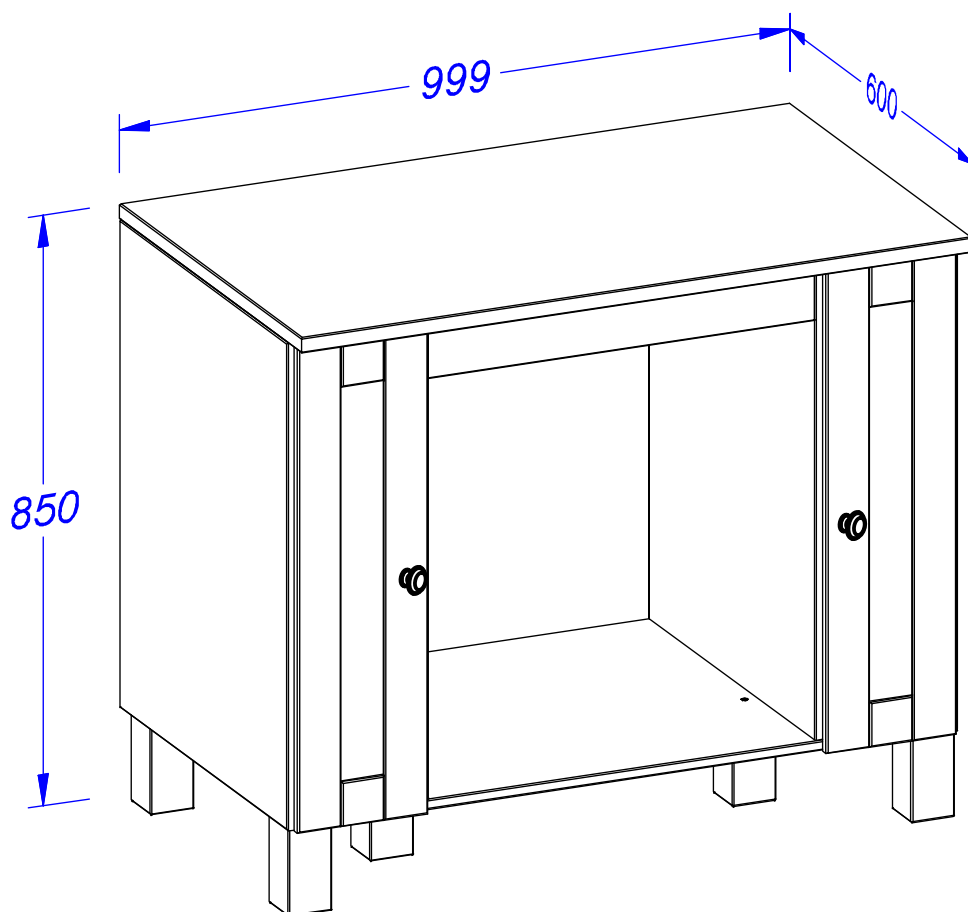

(D) *Montageanleitung*

(NL) *Handleiding voor de montage*

(TR) *Montaj talimatı*

(FR) *Notice de montage*

(CZ) *Montážní návod*

(HU) *Szerelési útmutató*

(GB) *Assembly instructions*

(PL) *Instrukcja montażu*

(RU) *Инструкция по монтажу*

(IT) *Istruzioni di montaggio*

(SK) *Návod na montáž*

(RO) *Instrucțiuni de montaj*

Service • Dienstverlening • Serwis • Servis • Сервисная служба • Assistenza • Szerviz

Name • Nom • Nome • Naam • Nazwa • Jméno •
Názov • Név • Denumire • Isim • Название

Nr. • No. • N° • Номер • Č • Sz

Typ • Type • Tip • Tipus • Тipo • Тип

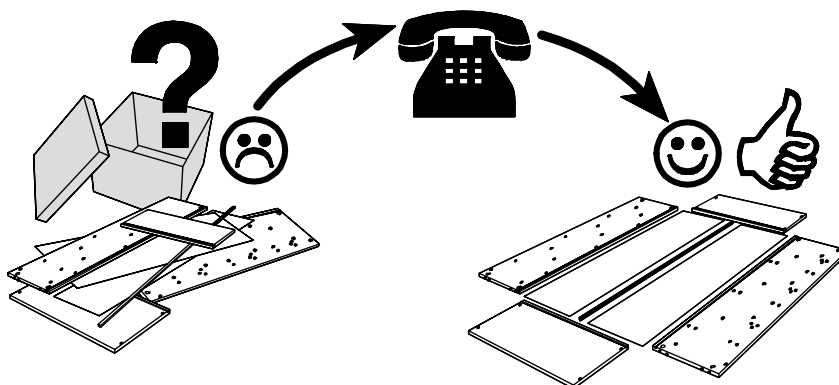
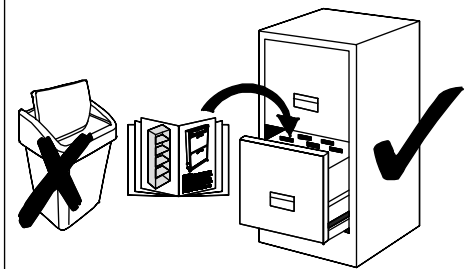

A10 22 x Ø8 x 35	B06 2 x Ø6,3 x 12	B52 12 x Ø7 x 50	C02 4 x fk.9 20 x	C20 4 x 2 mm 20 x	D06 2 x M4 x 20 50 x
E17 8 x Ø3,5 x 15	F04 1 x 4 mm	F08 1 x 45 x 20 x 16	G02 Ø15 x 11	G06 L - 34 20 x	I01 Ø1,2 x 20
K01 1 x 20 x 20 x 16 / 6,5	N01 24 x Ø5 / Ø5	P23 2 x Ø30x21			

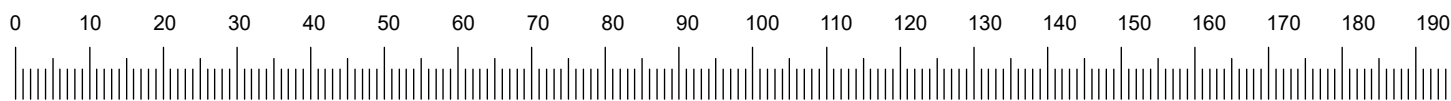
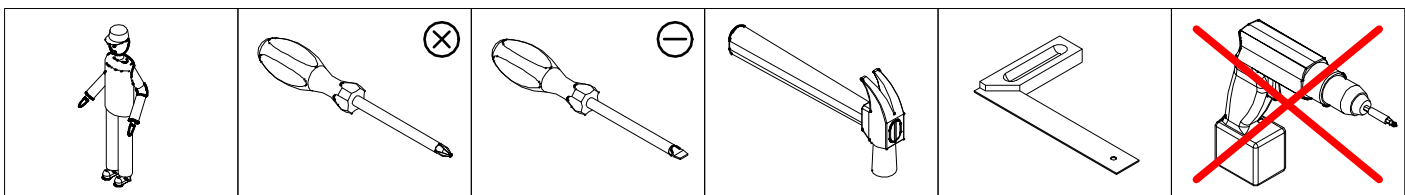

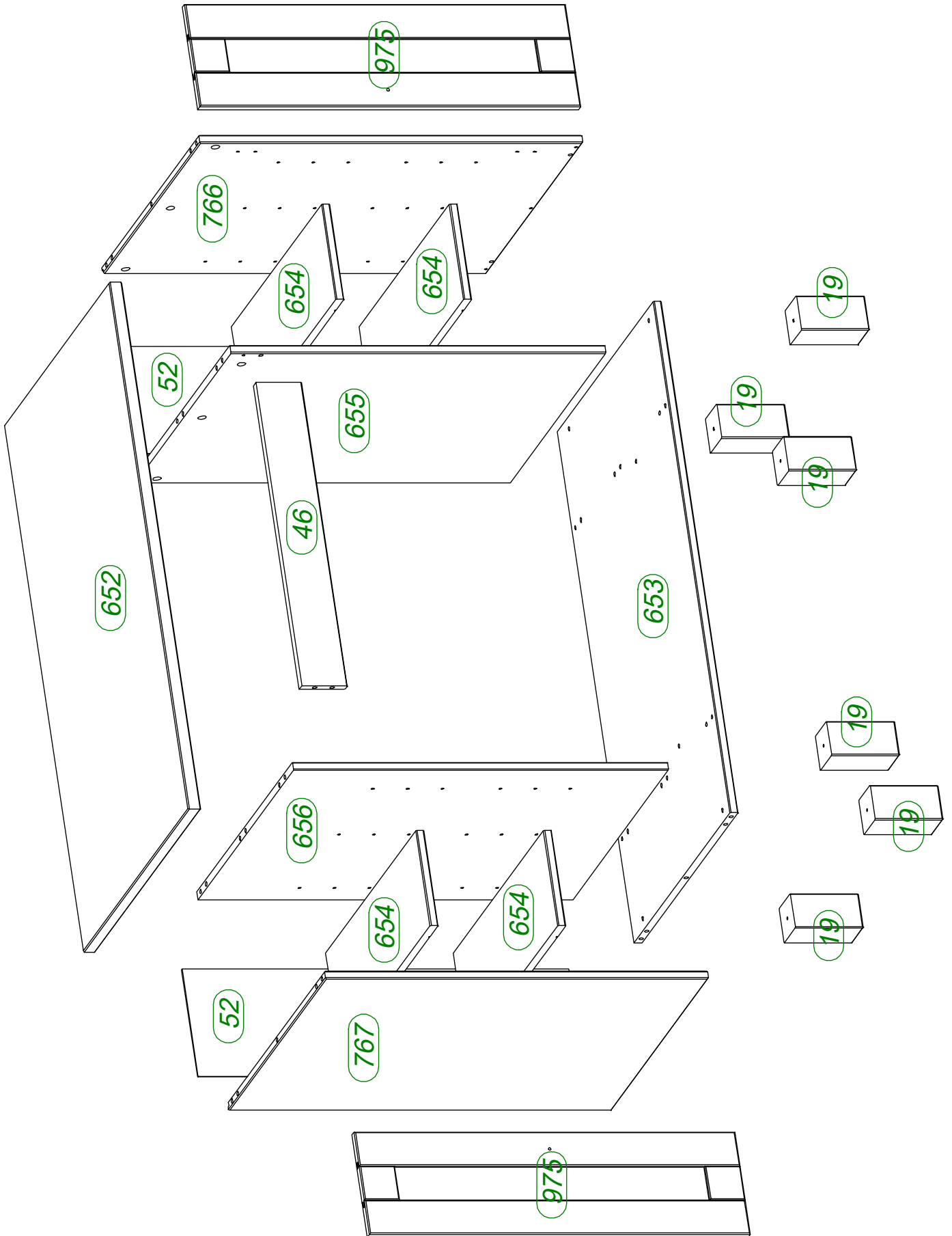



Achtung • Attention • Attenzione • Opgelet • Uwaga • Pozor • Figyelem • Atenție •
Dikkat • Вниманіе

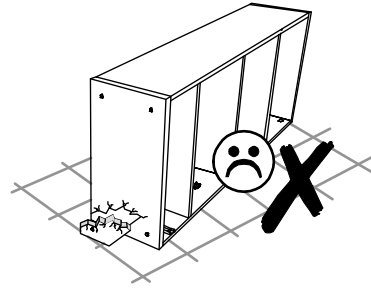
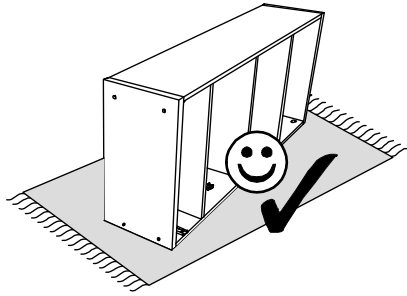

A10	16 x	C20	4 x	G06	8 x
Ø8 x 35		2 mm		L - 34	

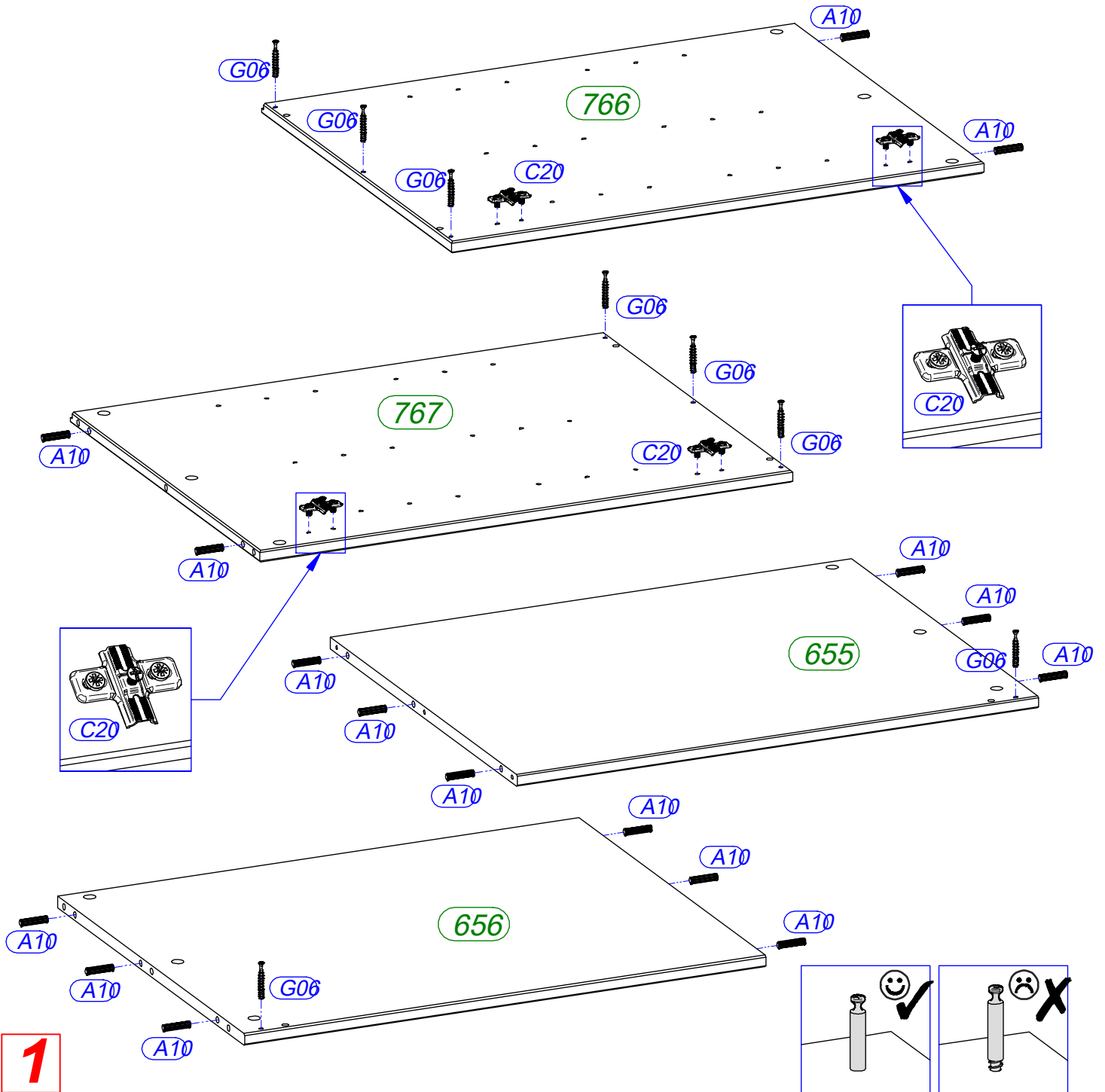

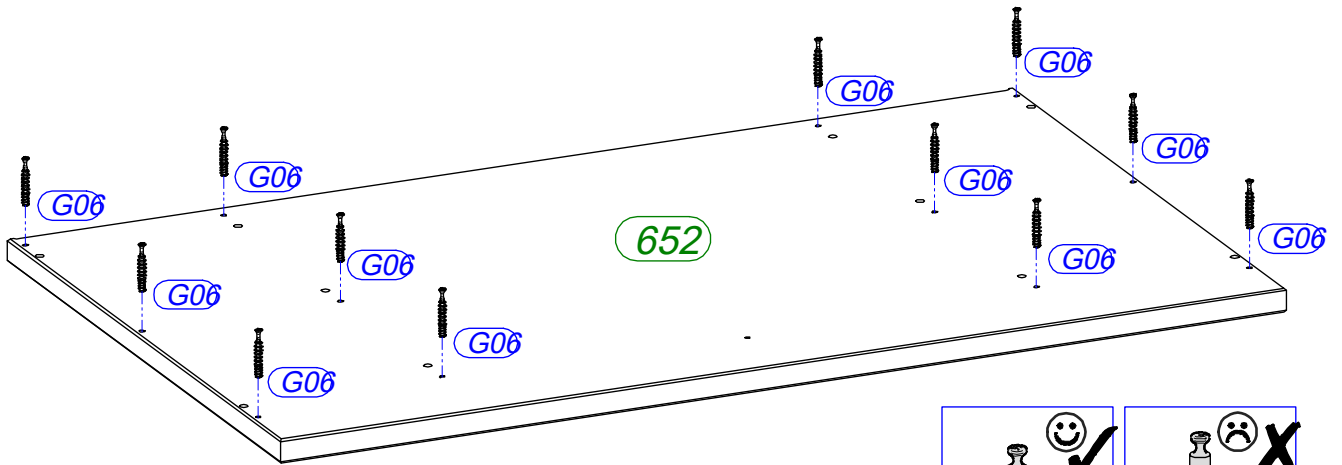
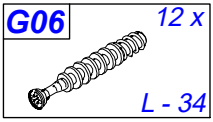

2

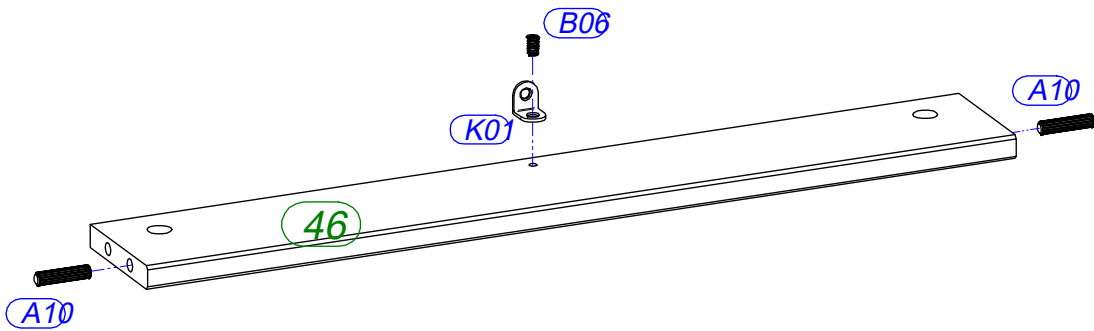
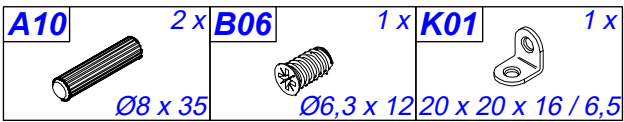
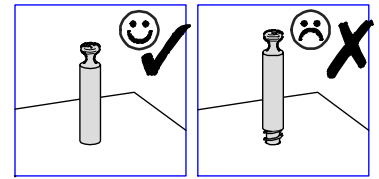

3

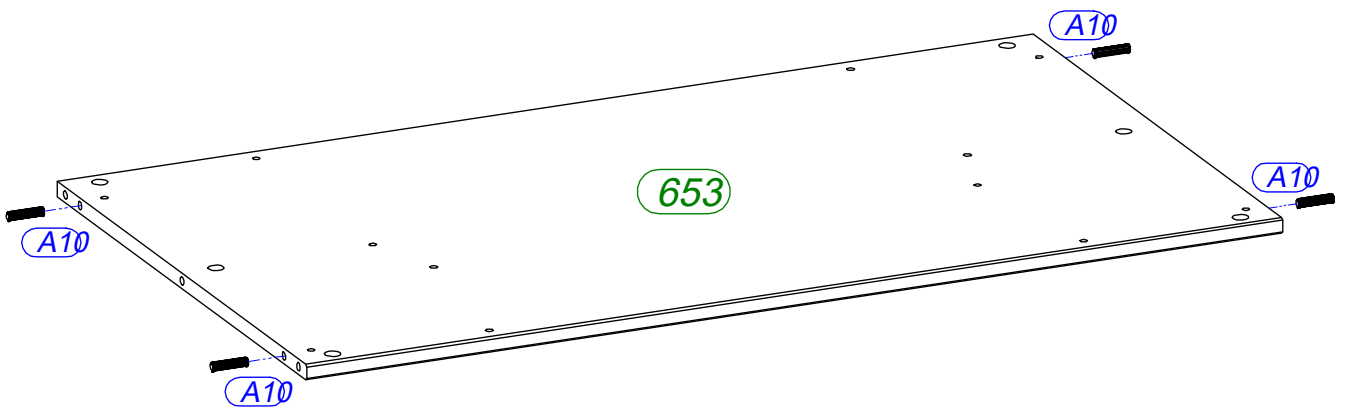
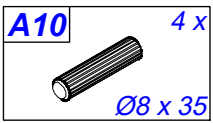

4

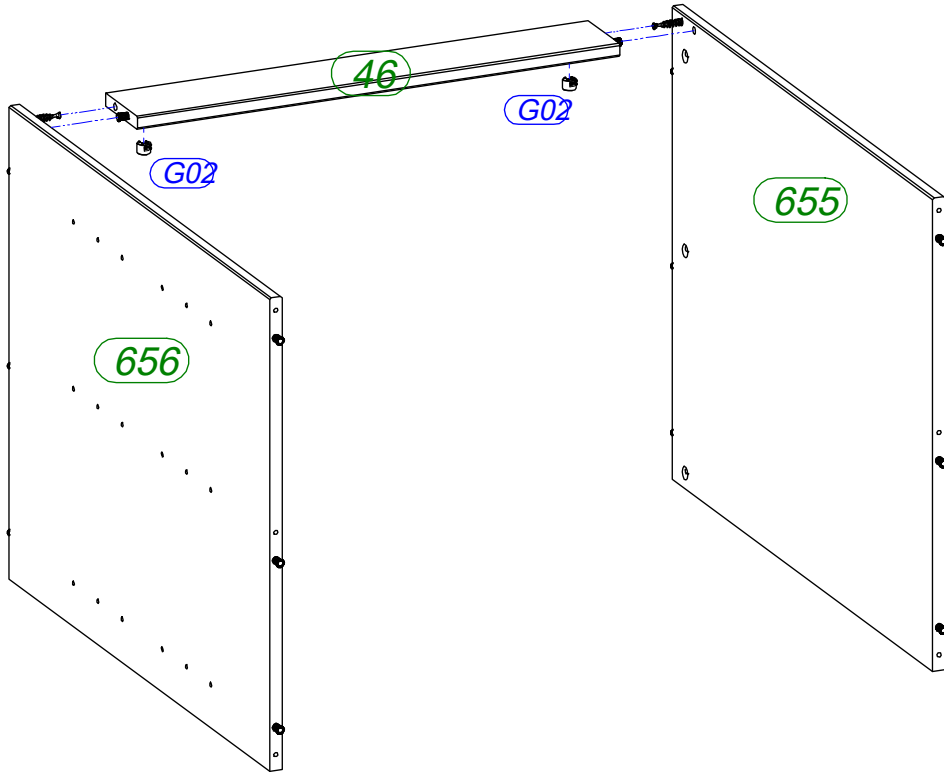
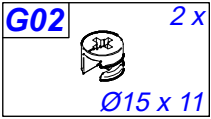

5

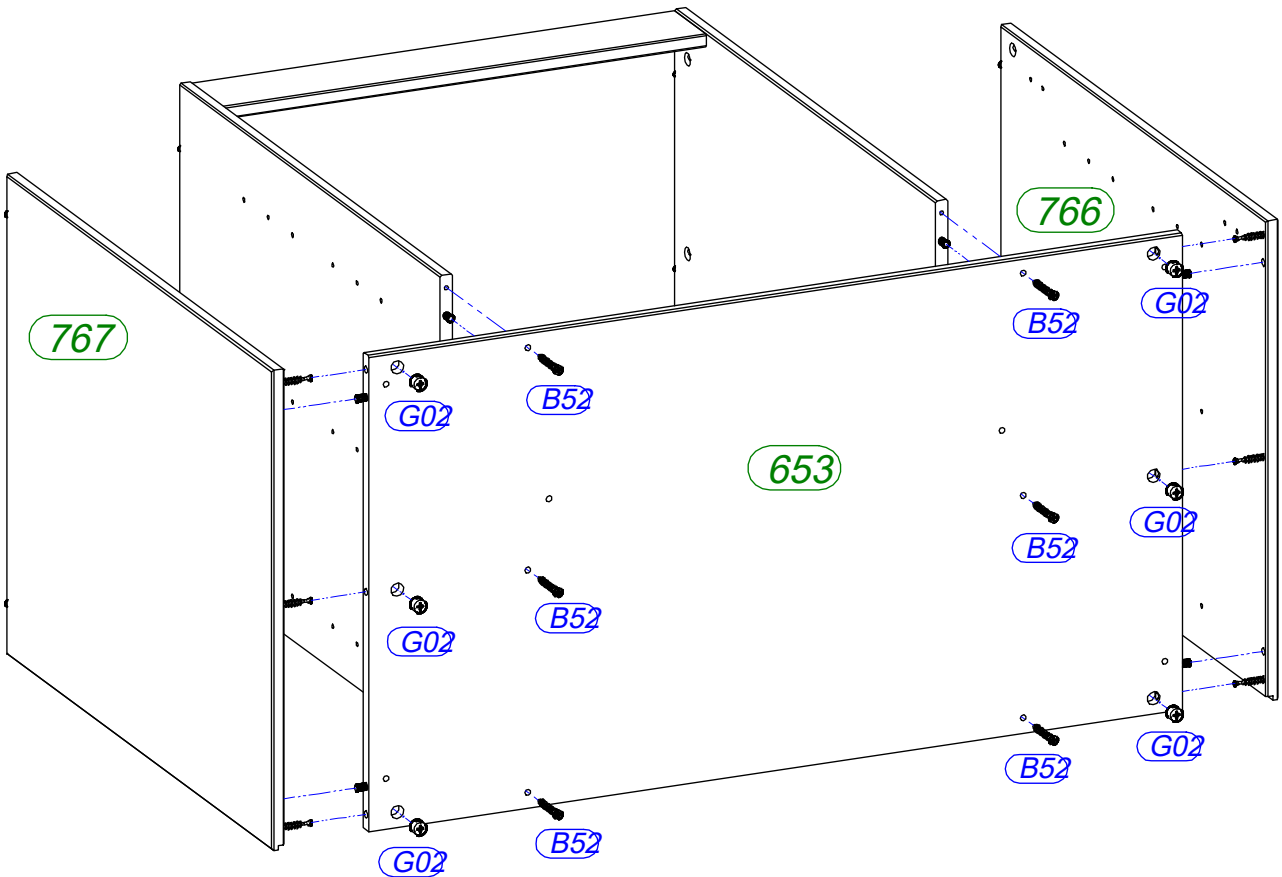
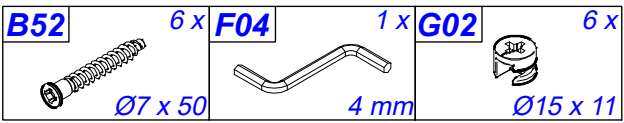

6

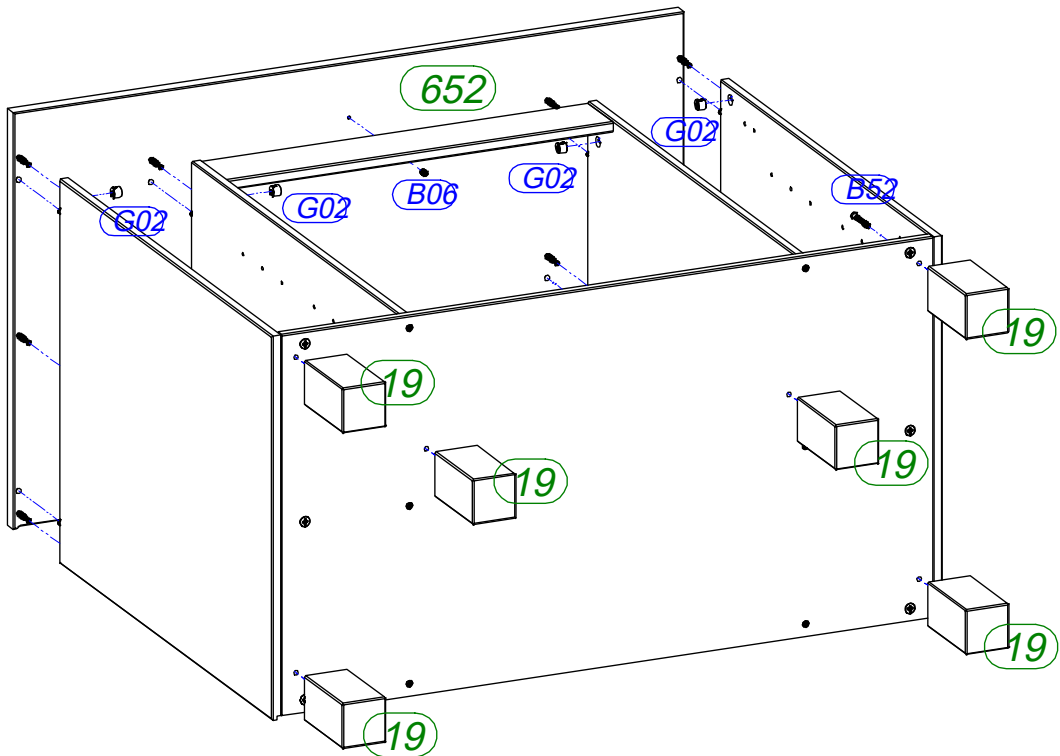
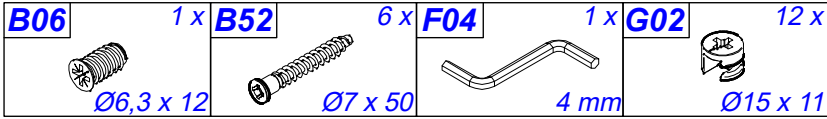



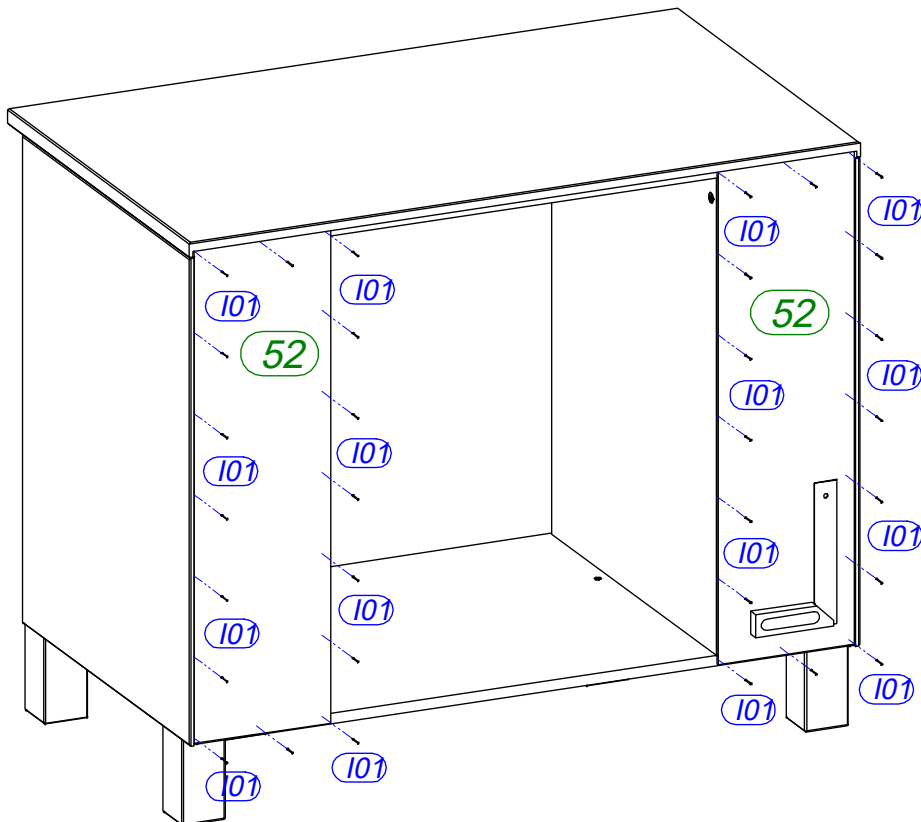
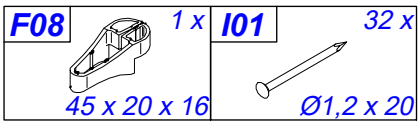

7

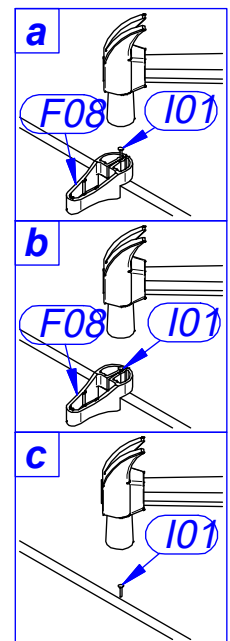

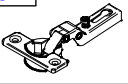
8



C02	4 x	D06	2 x	E17	8 x	P23	2 x
	fk.9		M4 x 20		Ø3,5 x 15		Ø30x21

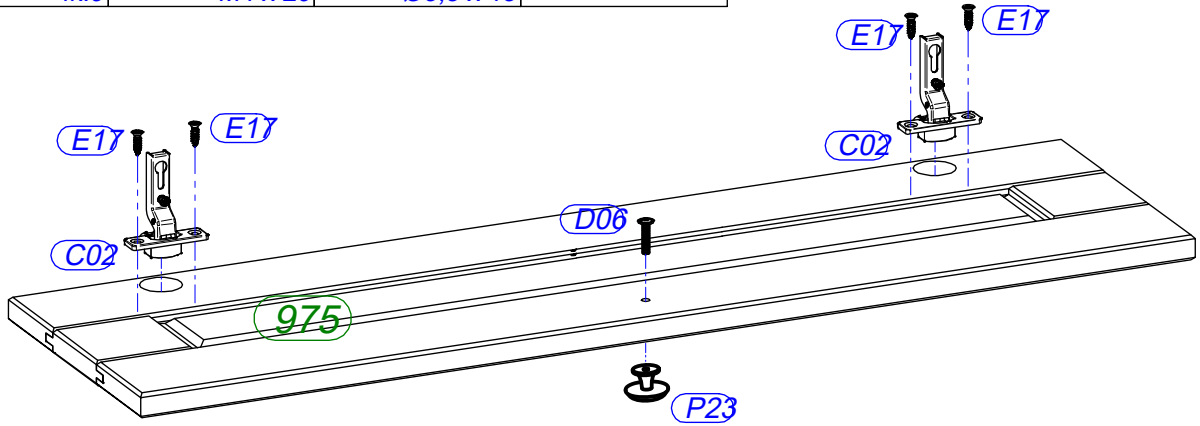

9x 2

N01	24 x
	Ø5 / Ø5

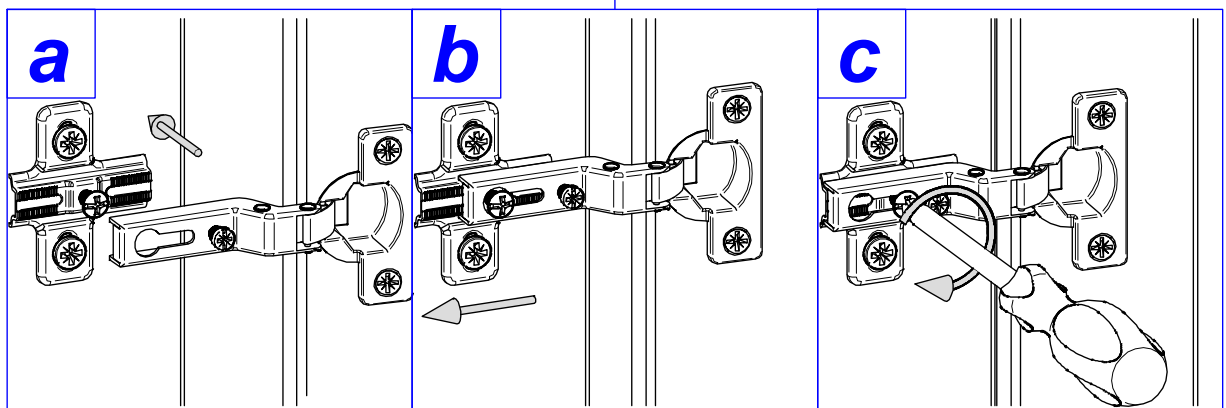
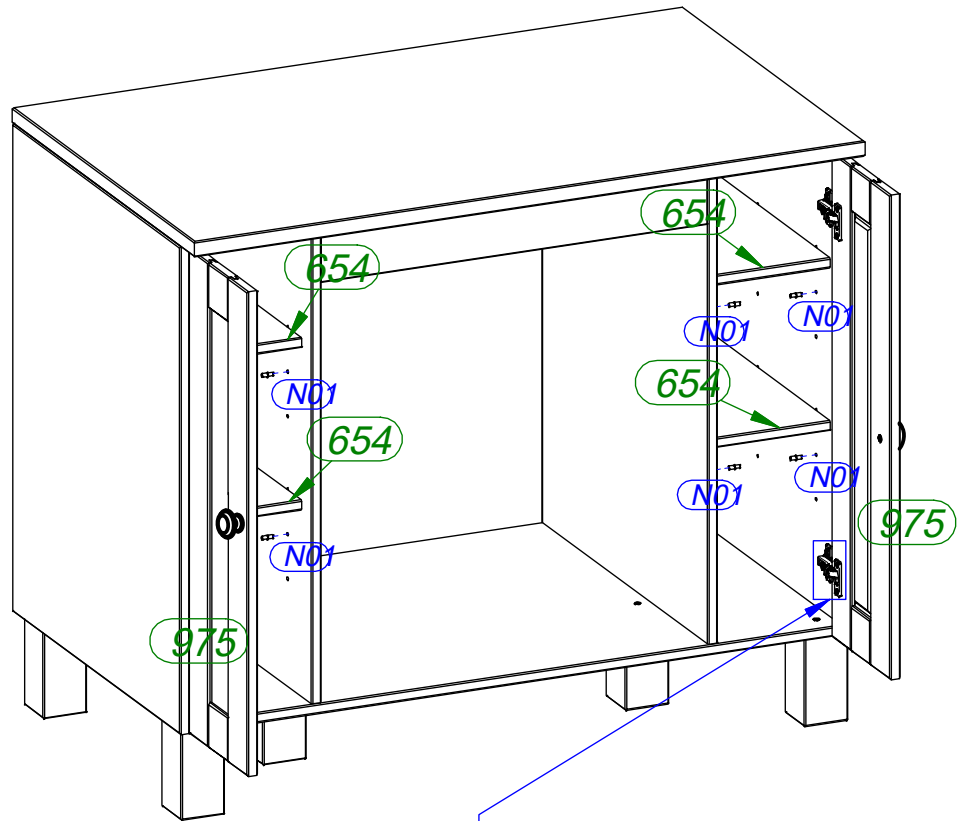

10



**Achtung • Attention • Attenzione • Opgelet • Uwaga • Pozor • Figyelem • Atenție •
Dikkat • Вниманіе**



(D)	Türen einstellen (Scharniere justieren)
(GB)	Adjusting the doors (adjusting the hinges)
(NL)	Deuren instellen (scharnieren afstellen)
(PL)	Nastawić drzwi (wyrównać zawiasy)
(TR)	Kapıların ayarlanması (menteşelerin seviye ayarı)
(RU)	Регулировка дверей (регулировка шарнира)
(FR)	Régler les portes (ajuster les charnières)
(IT)	Sistemare le porte (regolare le cerniere)
(CZ)	Vyrovnejte dvířka (seřďte závěsy)
(SK)	Nastavenie dverí (nastavenie závesov)
(HU)	Állítsa be az ajtókat (állítsa be a zsanérokat)
(RO)	Reglare ușii (ajustare balamale)

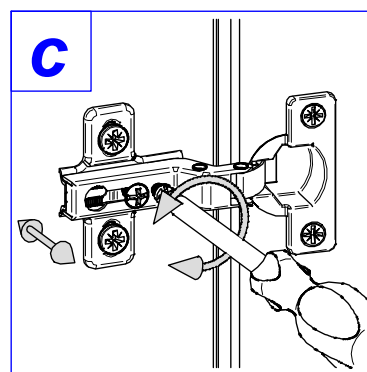
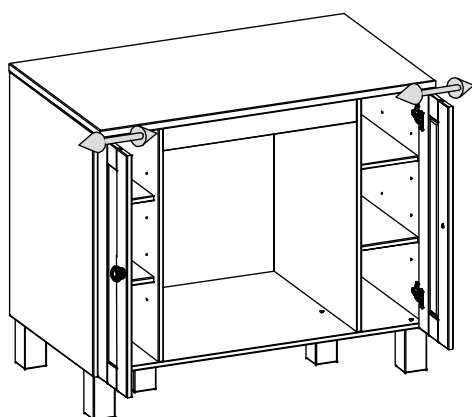
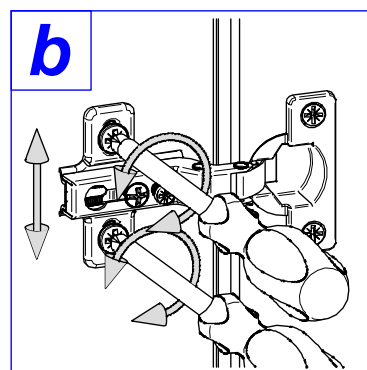
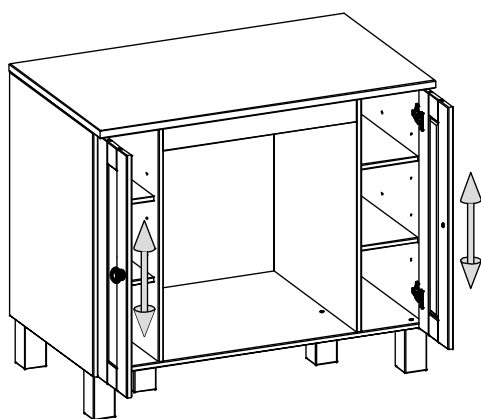
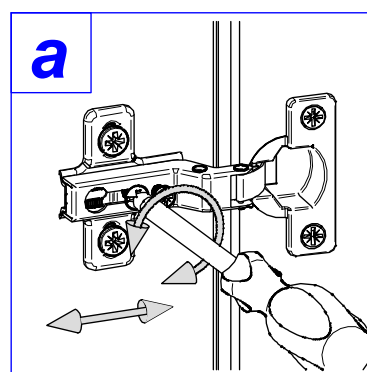
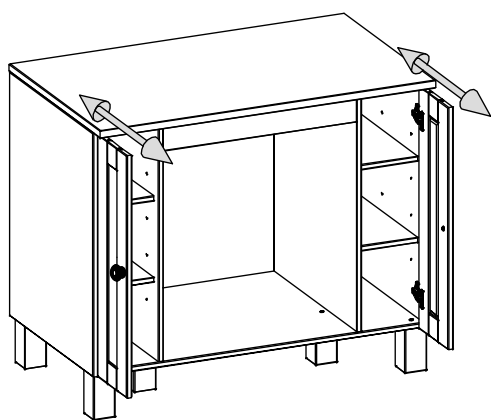

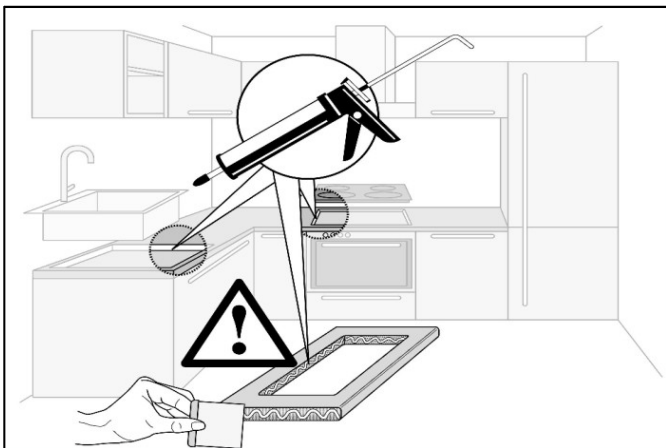
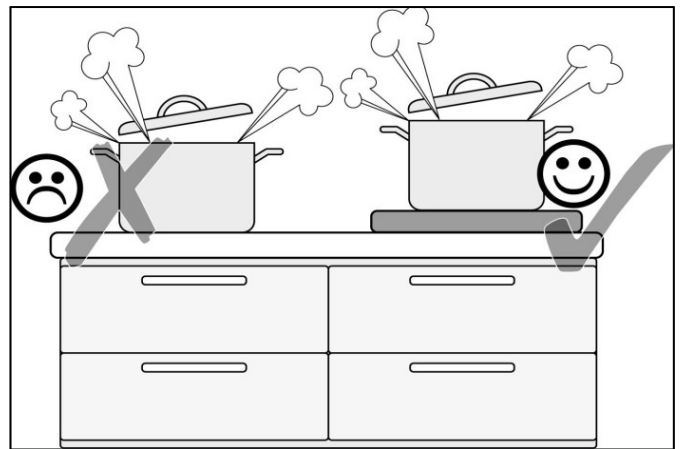
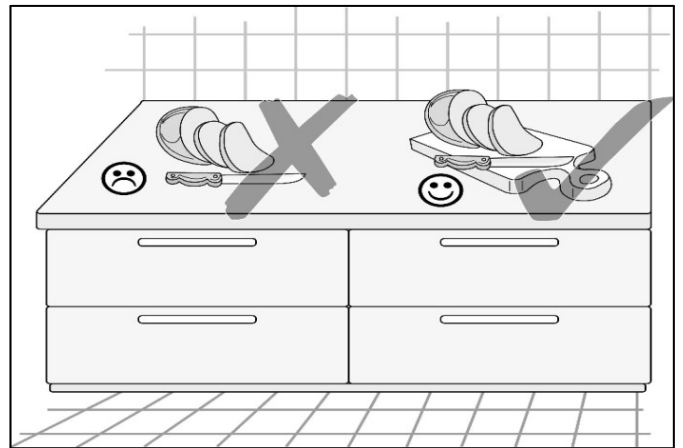
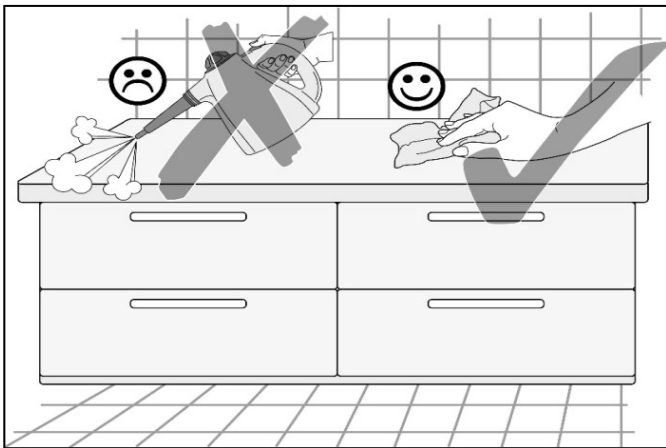
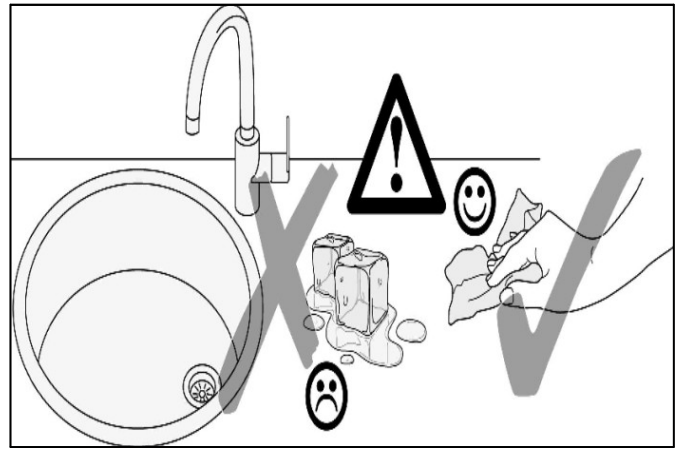
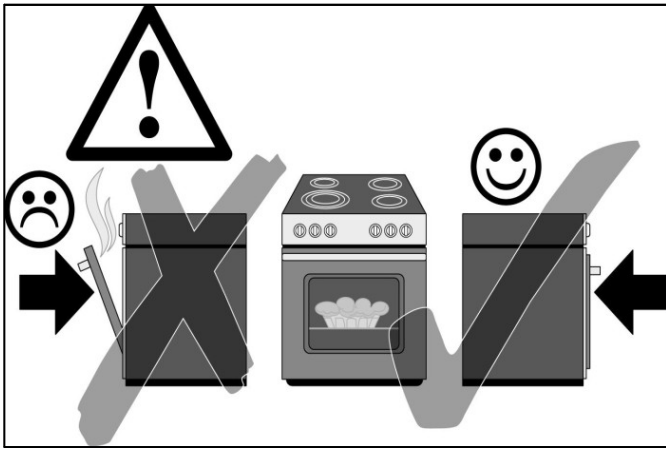

»1362«

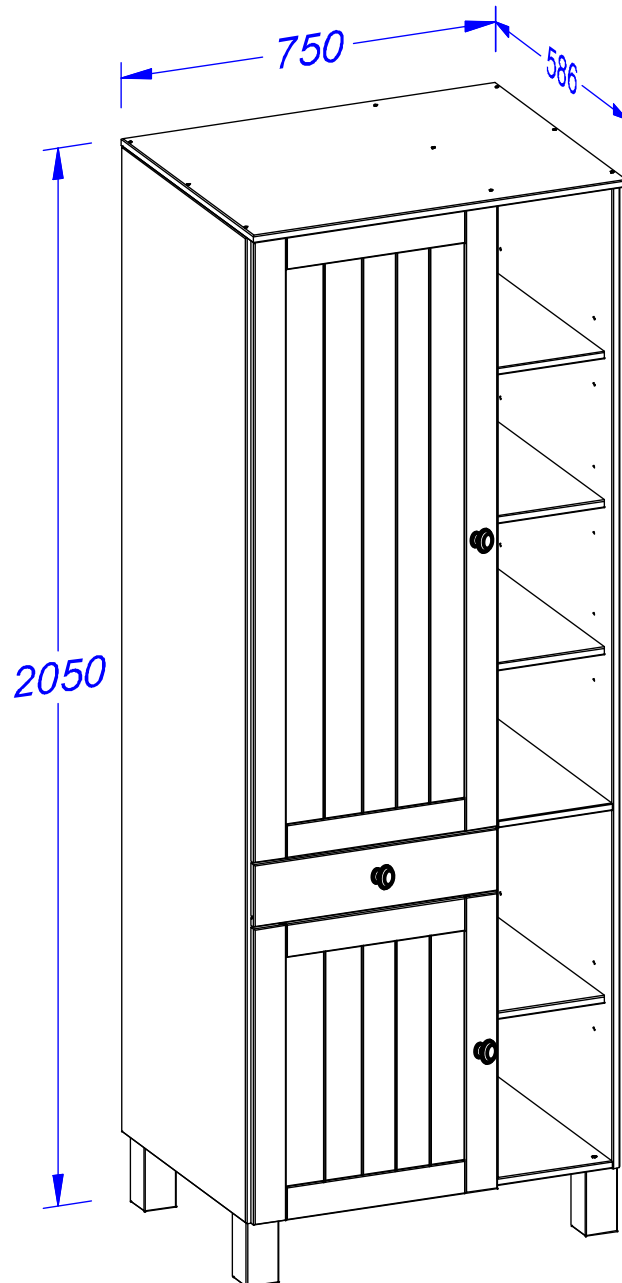

(D) *Montageanleitung*

(NL) *Handleiding voor de montage*

(TR) *Montaj talimatı*

(FR) *Notice de montage*

(CZ) *Montážní návod*

(HU) *Szerelési útmutató*

(GB) *Assembly instructions*

(PL) *Instrukcja montażu*

(RU) *Инструкция по монтажу*

(IT) *Istruzioni di montaggio*

(SK) *Návod na montáž*

(RO) *Instrucțiuni de montaj*

Service • Dienstverlening • Serwis • Servis • Сервисная служба • Assistenza • Szerviz

Name • Nom • Nome • Naam • Nazwa • Jméno •
Názov • Név • Denumire • Isim • Название

Nr. • No. • N° • Номер • Č • Sz

Turp • Type • Tip • Tipus • Tipo • Тип

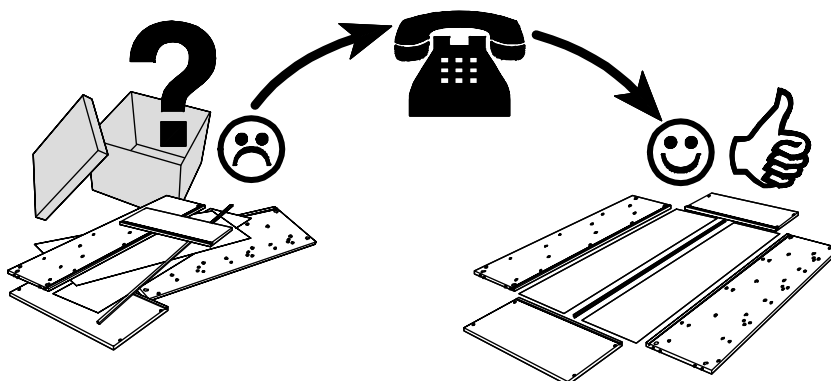
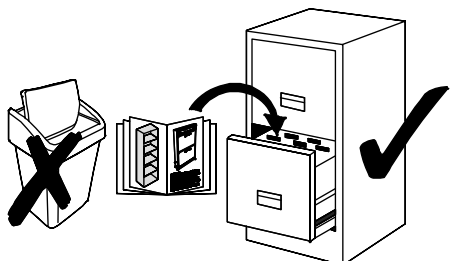

A10 18 x Ø8 x 35	A13 2 x Ø8 x 60	B03 6 x Ø5,8 x 11	B50 12 x Ø5 x 50	B52 4 x Ø7 x 50	C02 4 x fk.9
C20 4 x 2 mm	D02 2 x M4 x 10	D06 3 x M4 x 20	E17 10 x Ø3,5 x 15	E22 4 x Ø3,5 x 35	E38 1 x Ø4,0 x 60
F02 1 x 3 mm	F04 1 x 4 mm	F08 1 x 45 x 20 x 16	G02 20 x Ø15 x 11	G06 14 x L - 34	G08 6 x M4 / 7,0 x 34
G12 3 x M4 x Ø5 x 14	I01 75 x Ø1,2 x 20	K03 1 x 20 x 42 x 70	N01 28 x Ø5 / Ø5	P23 3 x Ø30x21	
Q02 2 x 17 x 430					

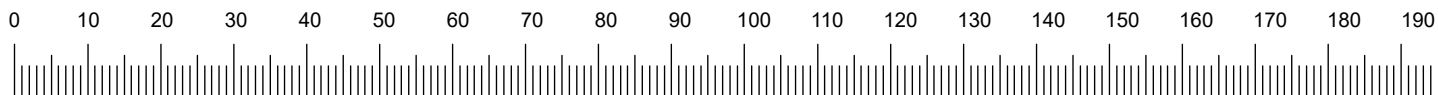
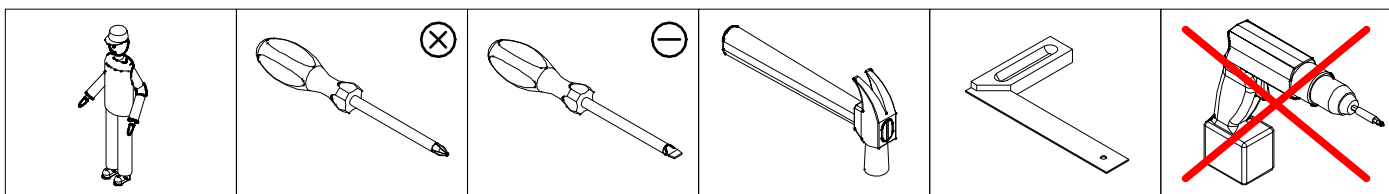

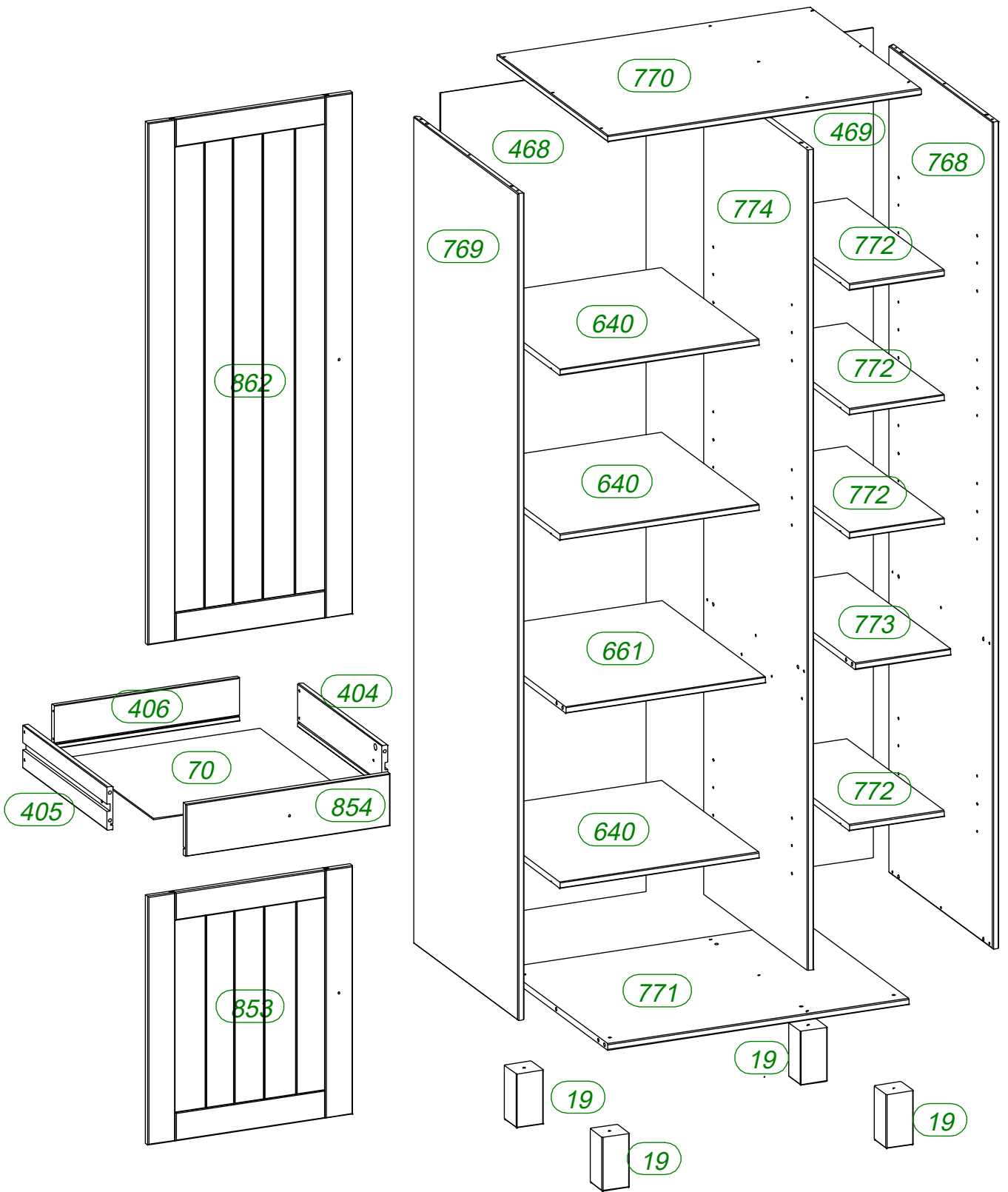

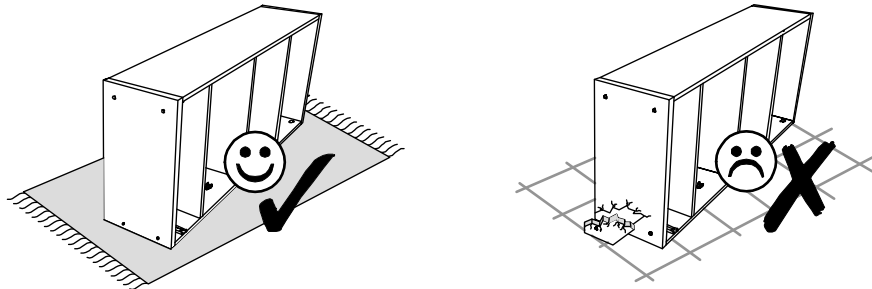

A10	4 x	B03	3 x	C20	4 x	G06	12 x	Q02	1 x
Ø8 x 35		Ø5,8 x 11		2 mm		L - 34		17 x 430	

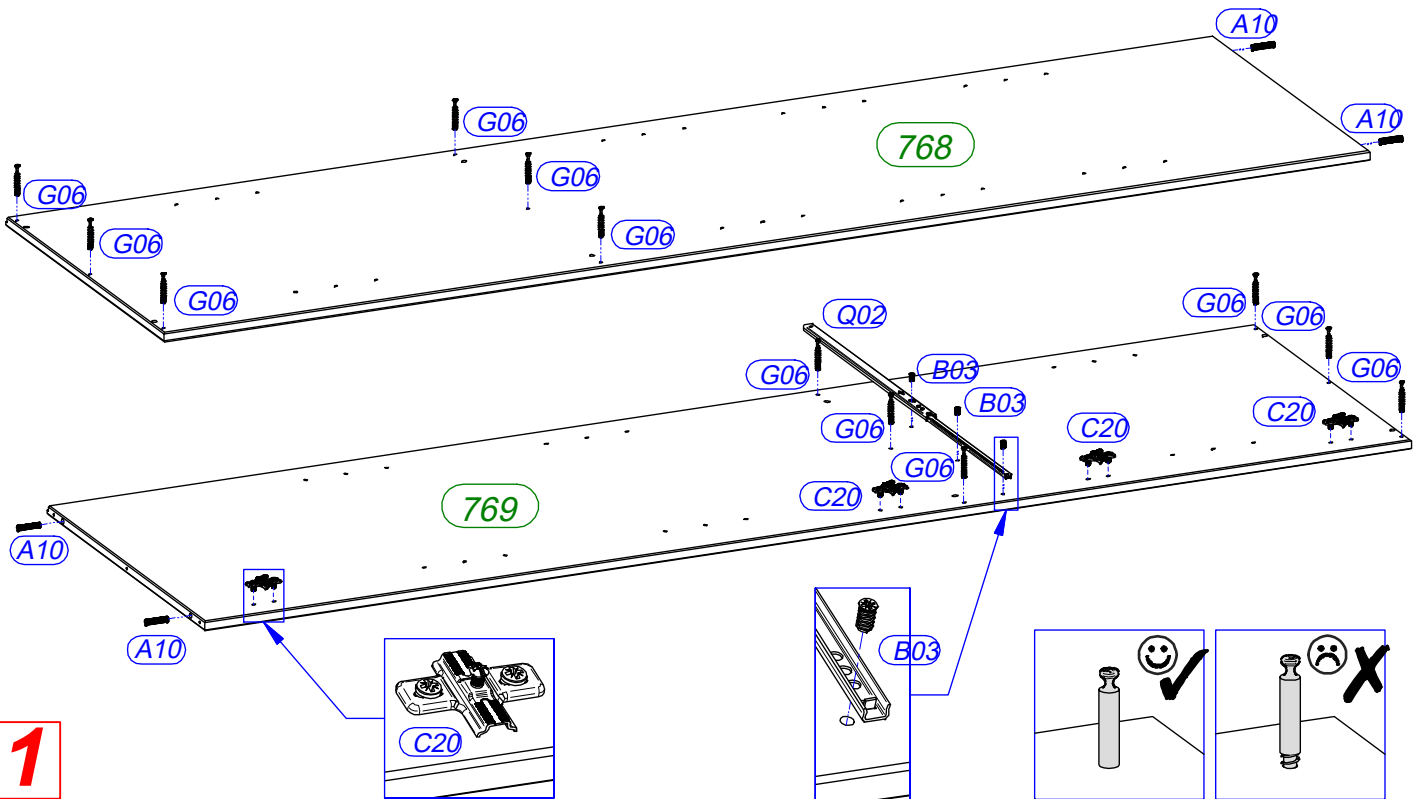

A10	4 x	B03	3 x	G08	6 x	G12	3 x	Q02	1 x
Ø8 x 35		Ø5,8 x 11		M4 / 7,0 x 34		M4 x Ø5 x 14		17 x 430	

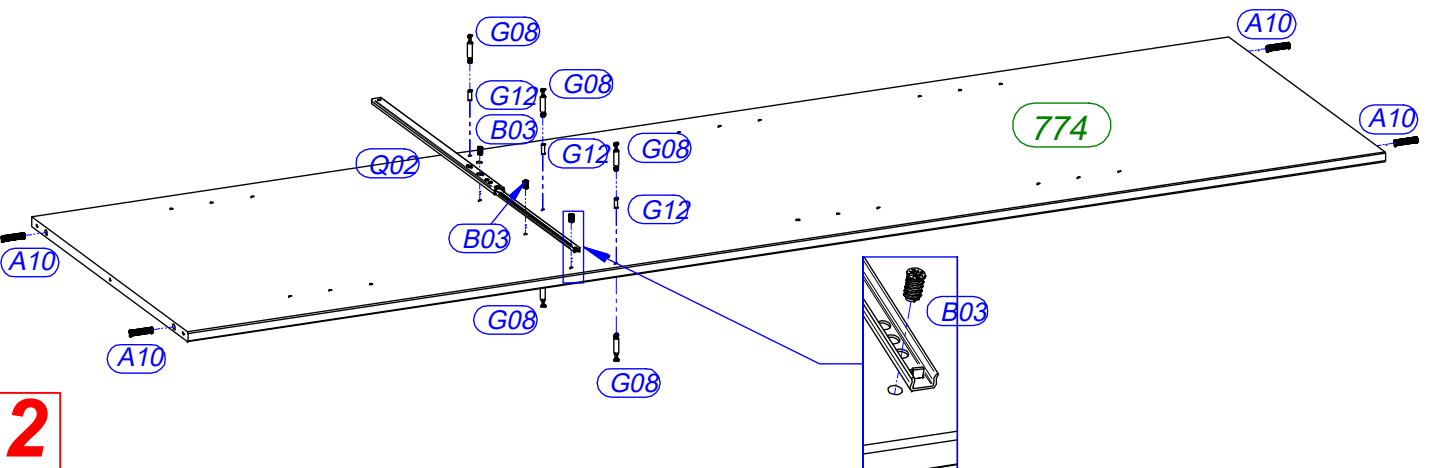

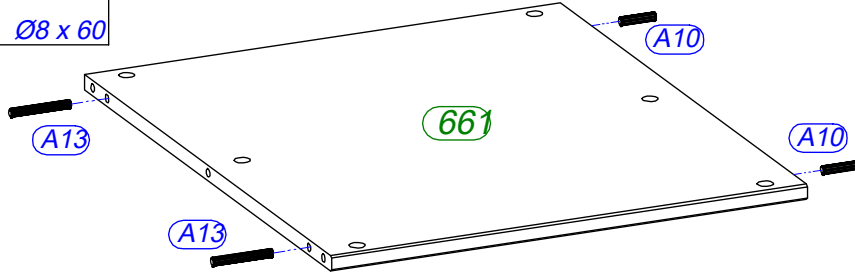
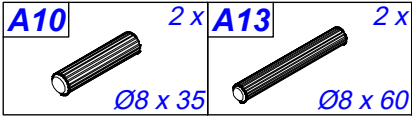

3

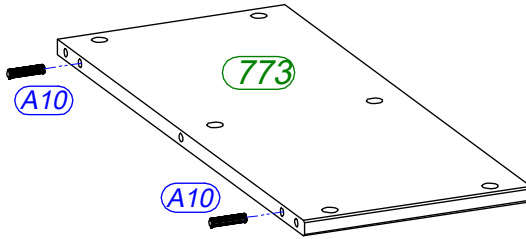
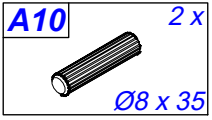

4

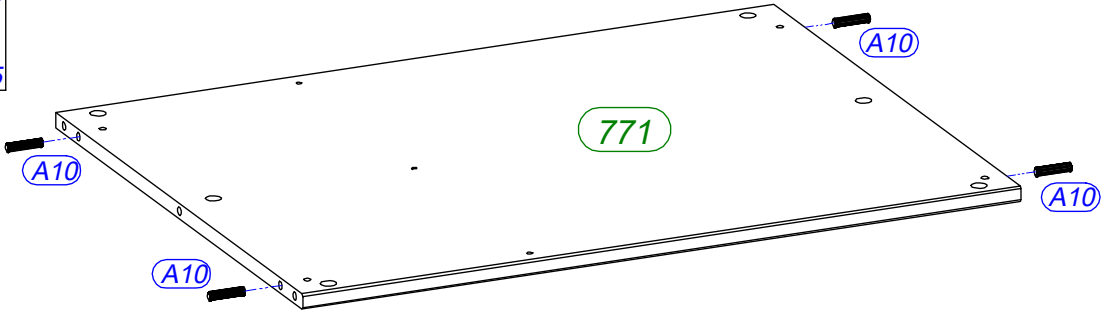
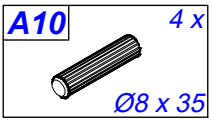

5

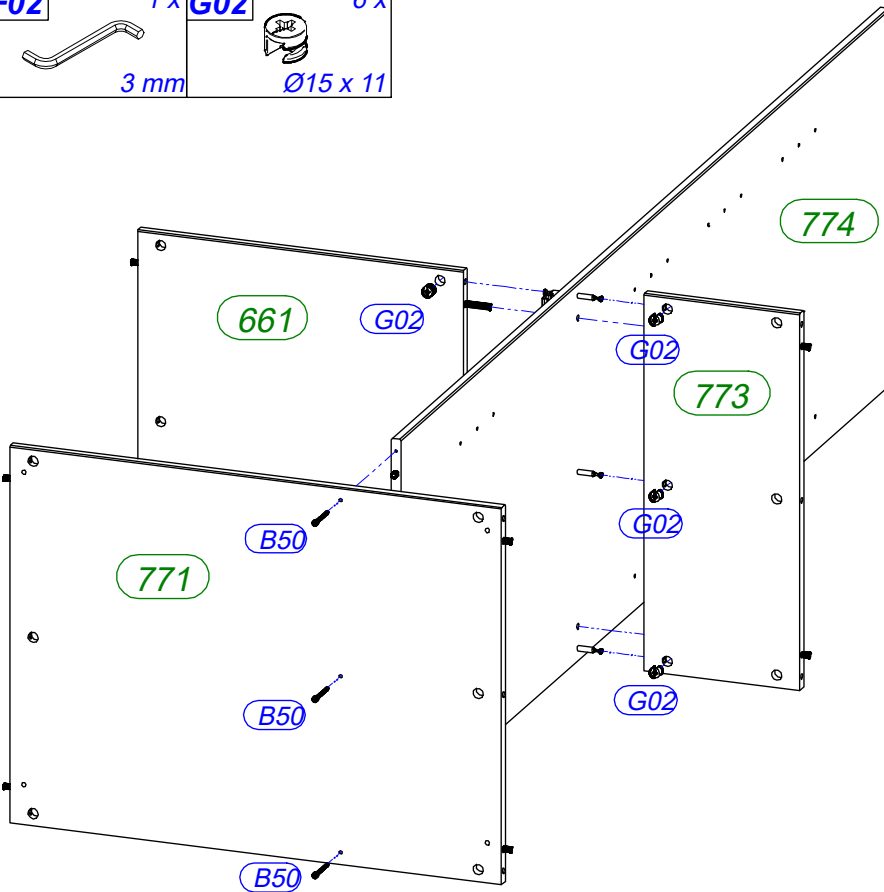
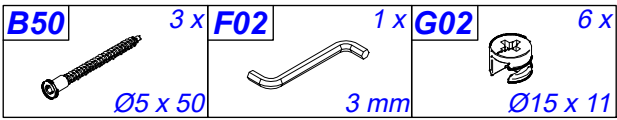

6

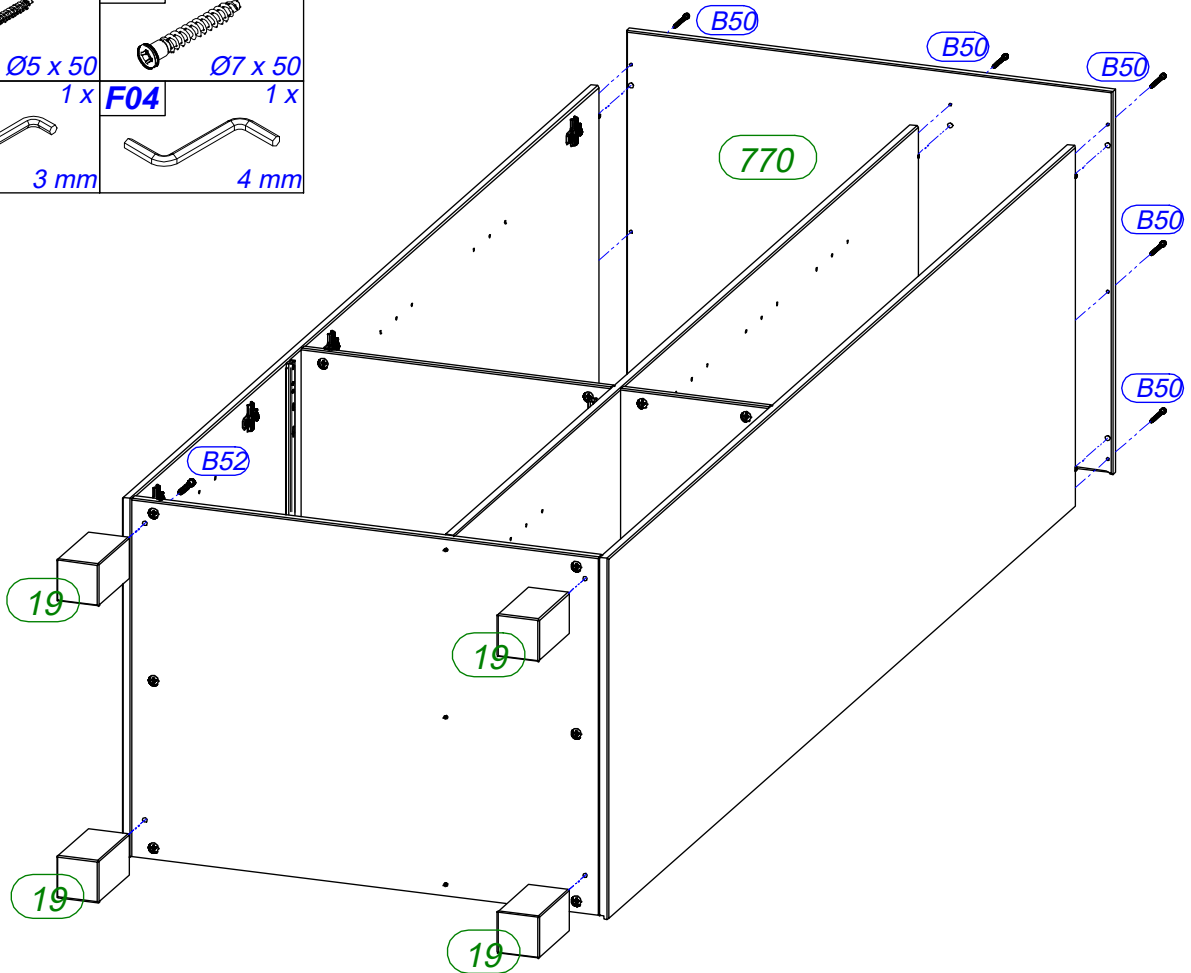
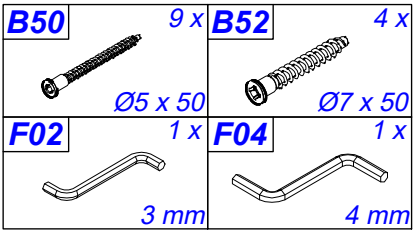
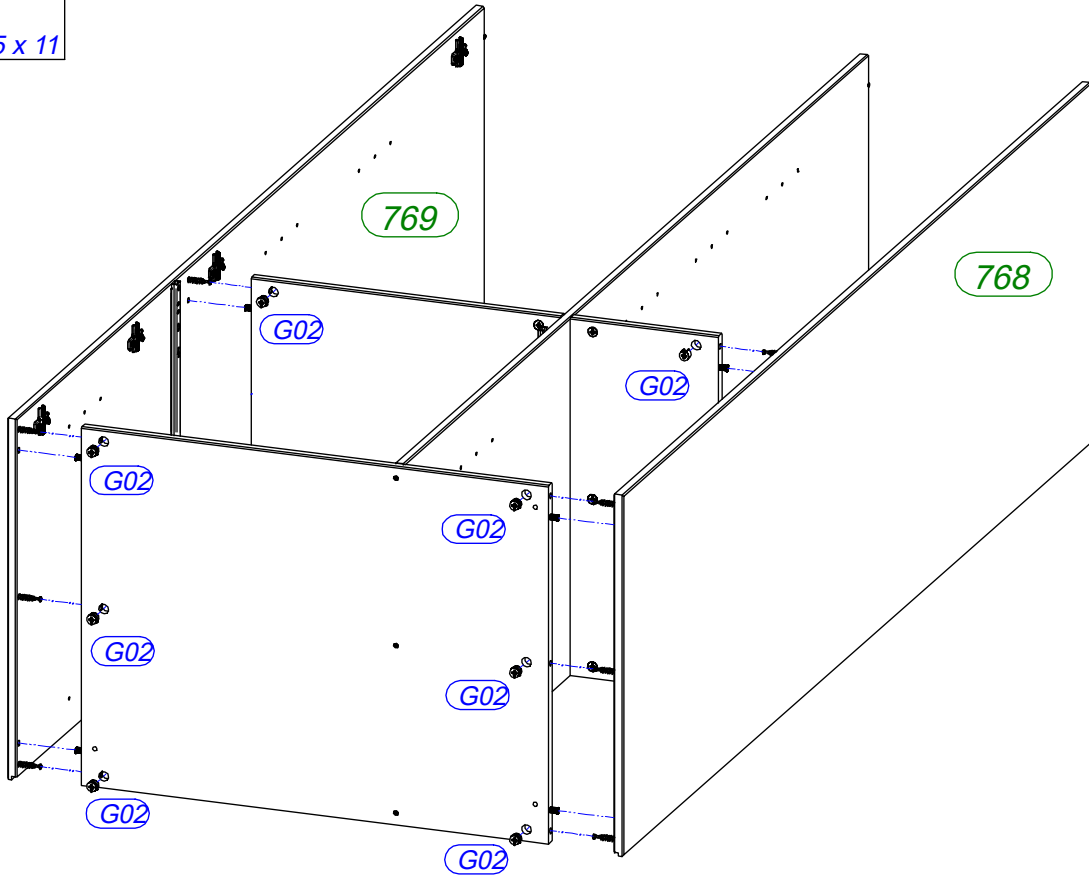
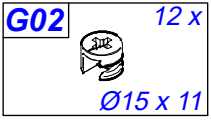

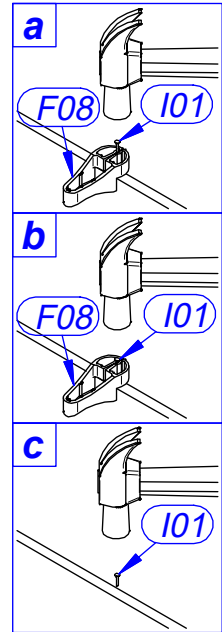
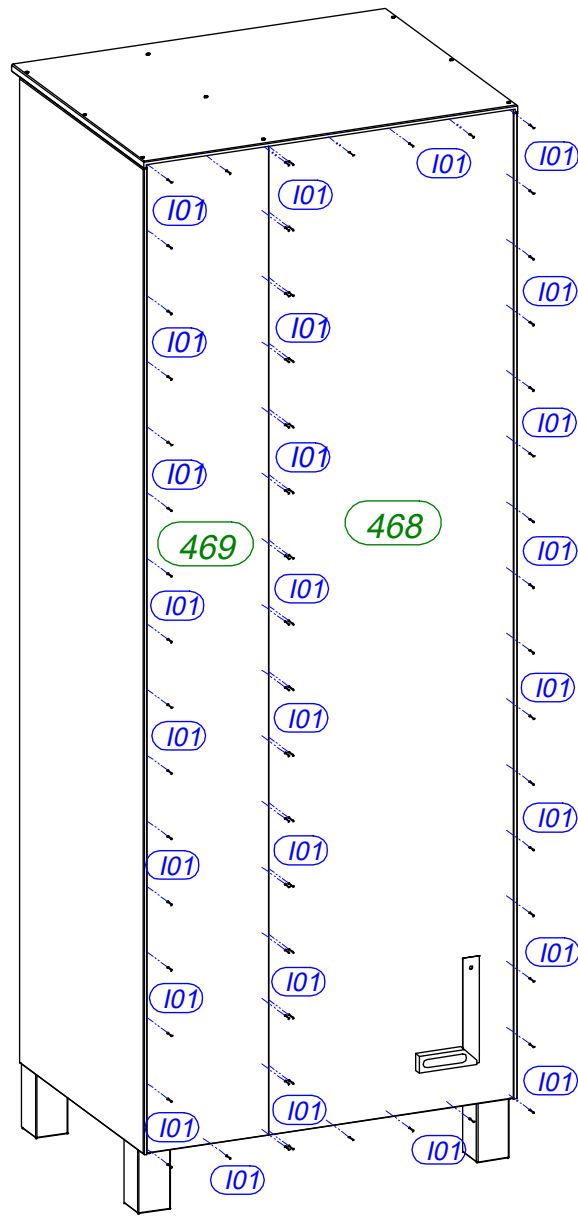
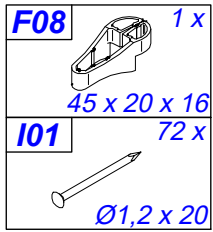

9

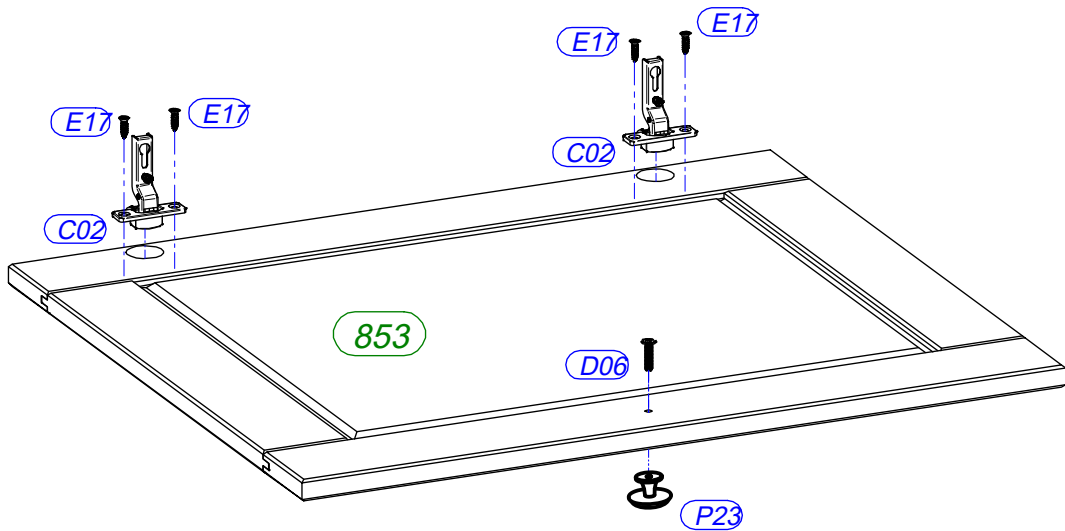
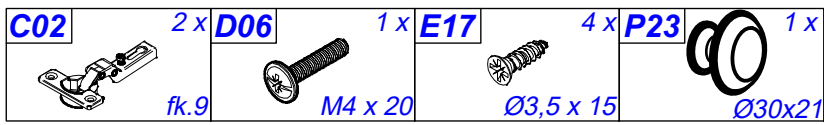

10

C02	2 x	D06	1 x	E17	4 x	P23	1 x
fk.9		M4 x 20		Ø3,5 x 15		Ø30x21	

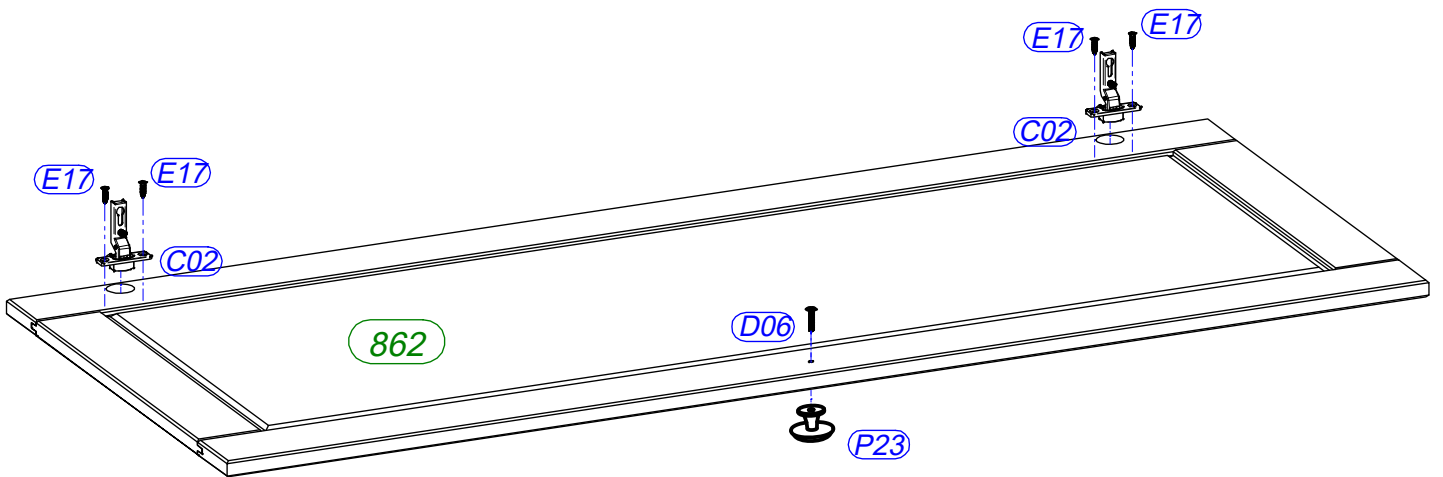

11

A10	2 x	D06	1 x	E22	4 x	G02	2 x	G06	2 x	P23	1 x
Ø8 x 35		M4 x 20		Ø3,5 x 35		Ø15 x 11		L - 34		Ø30x21	

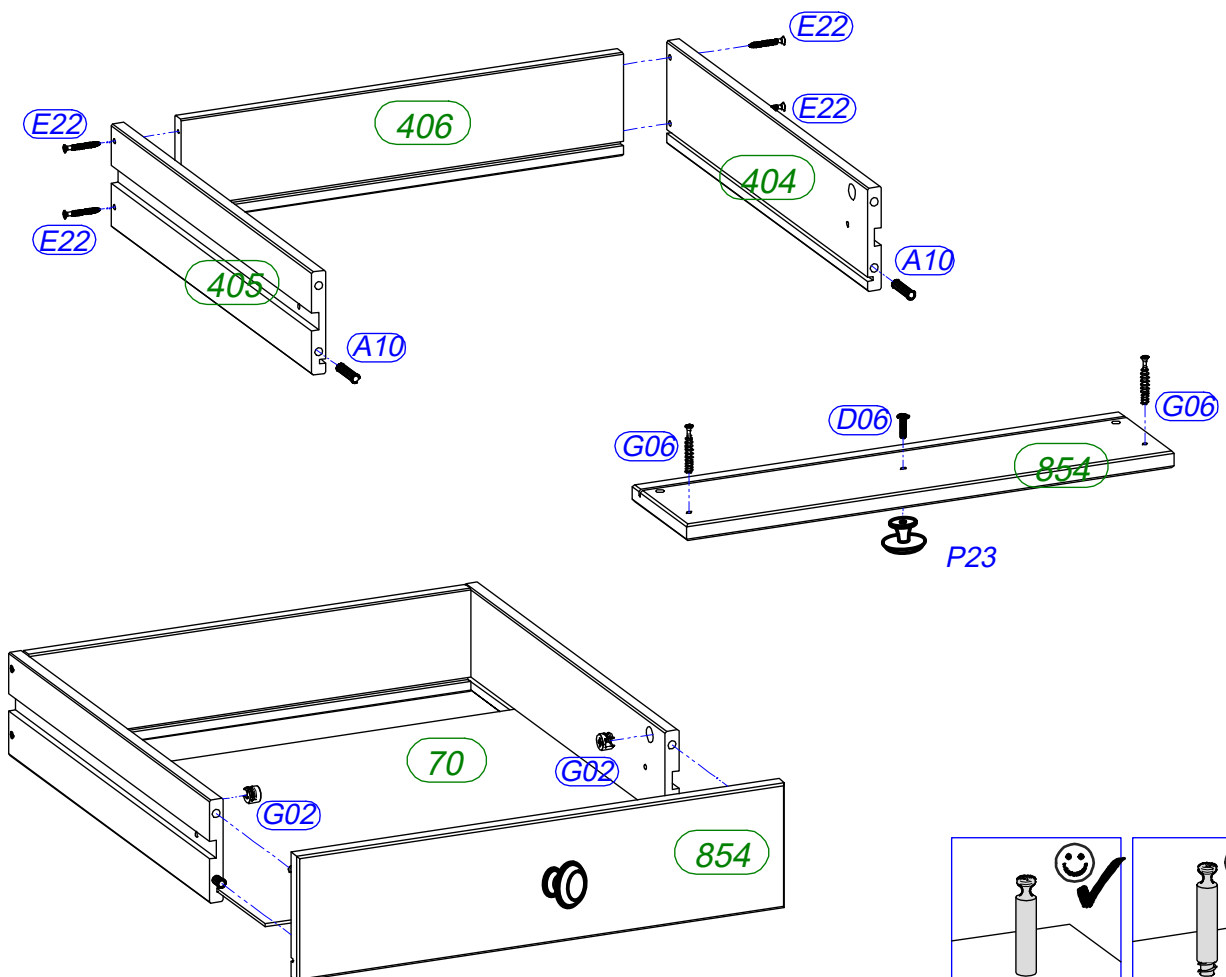

12

Achtung • Attention • Attenzione • Opgelet • Uwaga • Pozor • Figyelem • Atenție • Dikkat • Вниманіе	
(D)	Wandbefestigung dient als Kippschutz – unbedingt anbringen! Bei einigen Wandtypen kann ein Spezialdübel erforderlich sein!
(GB)	The wall fastening serves to prevent tipping – be absolutely sure to mount it! For certain wall types, a special dowel may be necessary!
(NL)	Bevestiging aan de muur dient als kantelbescherming – zeker en vast bevestigen! Bij enkele muurtypes is een speciale plug misschien vereist!
(PL)	Mocowanie do ściany jest jednocześnie zabezpieczeniem przed przewróceniem – koniecznie zamontować! Do niektórych rodzajów ścian konieczne mogą być specjalne wkrety!
(TR)	Duvardaki sabitleme, devrilmeye karşı bir emniyet tedbiridir ve mutlaka monte edilmelidir! Bazı duvar tiplerinde bunun için özel bir dübel gerekli olabilir!
(RU)	Обязательно установите крепление на стене во избежание опрокидывания! Для некоторых типов стен может потребоваться специальный дюбель!
(FR)	La fixation murale sert de protection contre le basculement – à installer impérativement ! Pour certains types de murs il faut des chevilles spéciales !
(IT)	Il fissaggio alla parete serve da protezione anti-ribaltamento – attaccarla assolutamente! Per alcune strutture di parete può essere necessario un tassello speciale!
(CZ)	Montáž na stěnu slouží jako ochrana proti převrnutí – bezpodmínečně umístěte! U některých typů stěn může být zapotřebí speciální hmoždinka!
(SK)	Upevnenie na stenu slúži ako ochrana proti prevráteniu – bezpodmienečne použite! Pre niektoré druhy stien môže byť potrebná špeciálna hmoždinka!
(HU)	A termék a falhoz kel rögzíténi, különben az felborulhat! Egyes faltípusoknál speciális tiplít kell használni!
(RO)	Sistemul de fixare la perete servește ca protecție la răsturnarede montat obligatoriu! Pentru unele tipuri de pereți este posibil să fie necesar un diblu special!

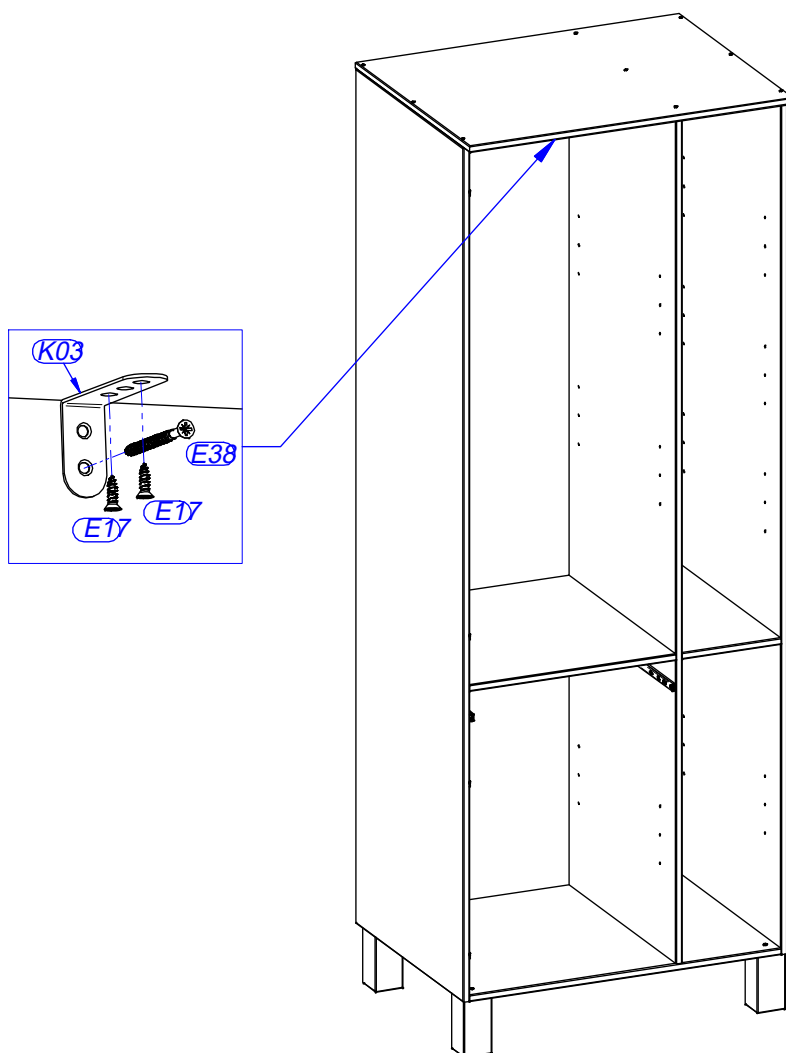

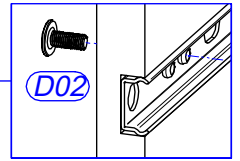
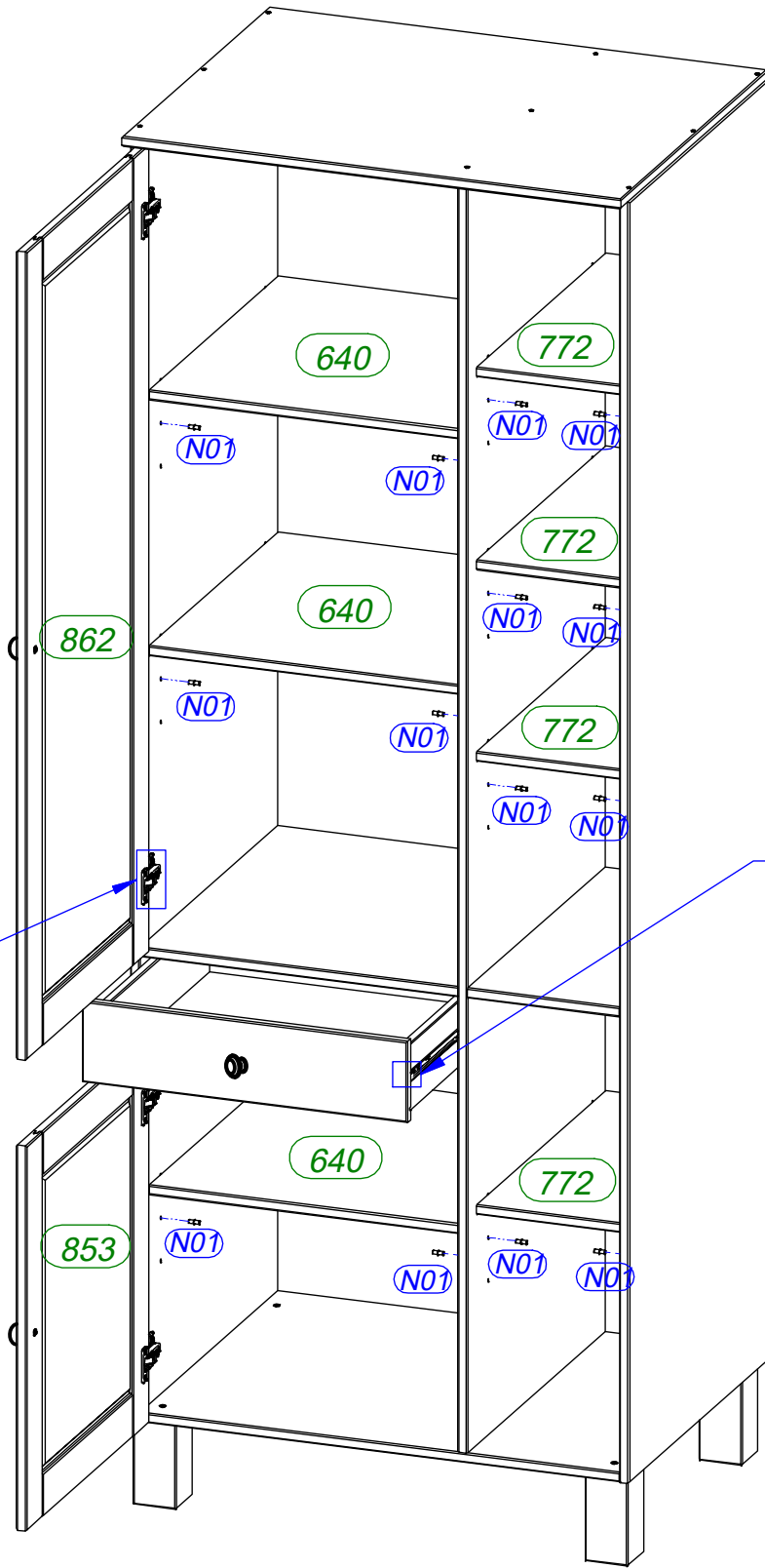
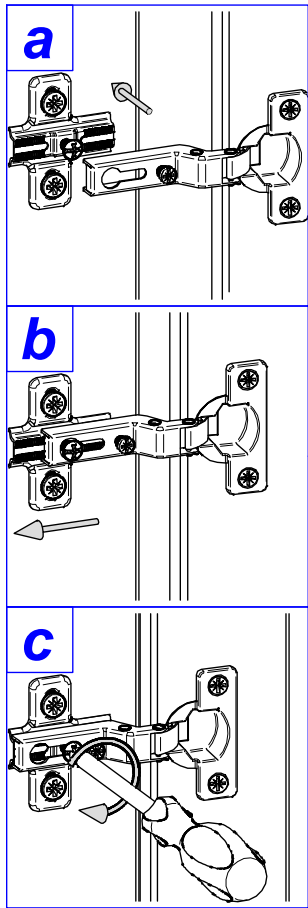
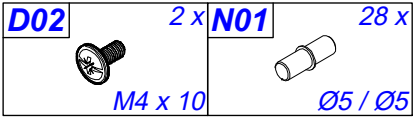

**Achtung • Attention • Attenzione • Opgelet • Uwaga • Pozor • Figyelem • Atenție •
Dikkat • Внимание**

D	Türen einstellen (Scharniere justieren)
GB	Adjusting the doors (adjusting the hinges)
NL	Deuren instellen (scharnieren afstellen)
PL	Nastawić drzwi (wyrównać zawiasy)
TR	Kapıların ayarlanması (menteşelerin seviye ayarı)
RU	Регулировка дверей (регулировка шарнира)
FR	Régler les portes (ajuster les charnières)
IT	Sistemare le porte (regolare le cerniere)
CZ	Vyrovnejte dvířka (seřďte závěsy)
SK	Nastavenie dverí (nastavenie závesov)
HU	Állítsa be az ajtókat (állítsa be a zsanérokat)
RO	Reglare ușii (ajustare balamale)

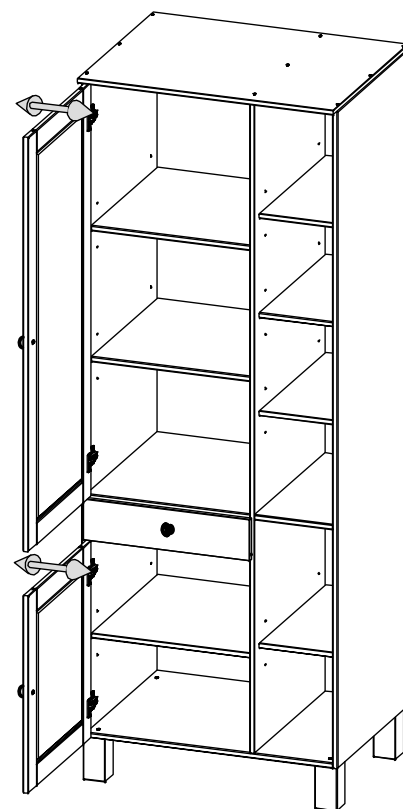
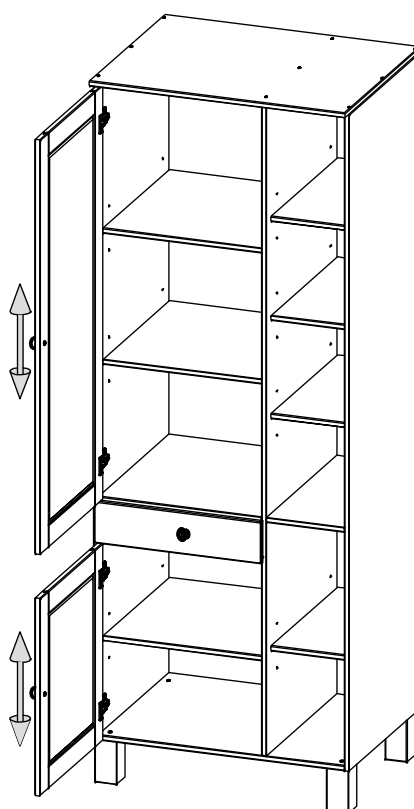
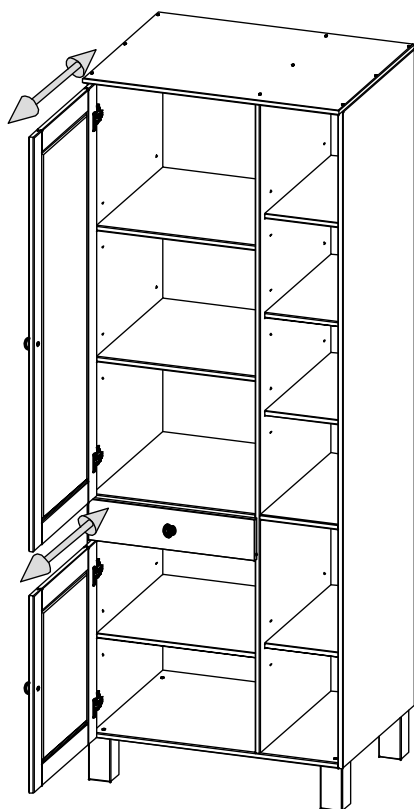
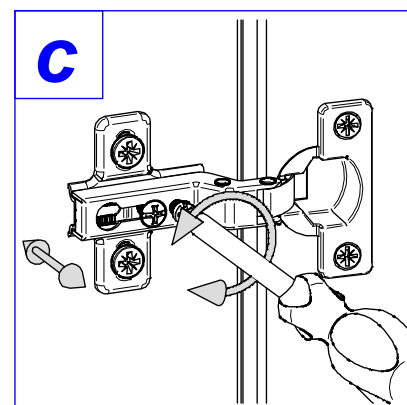
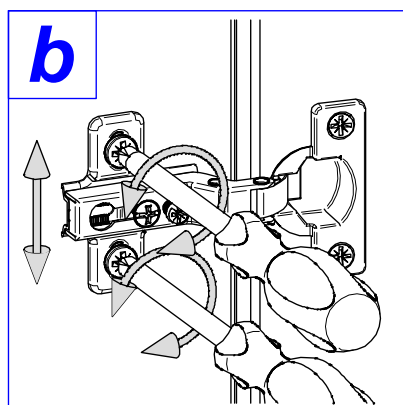
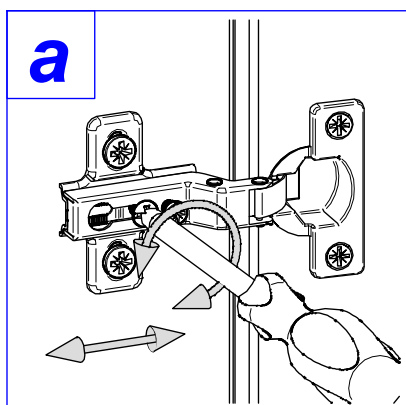

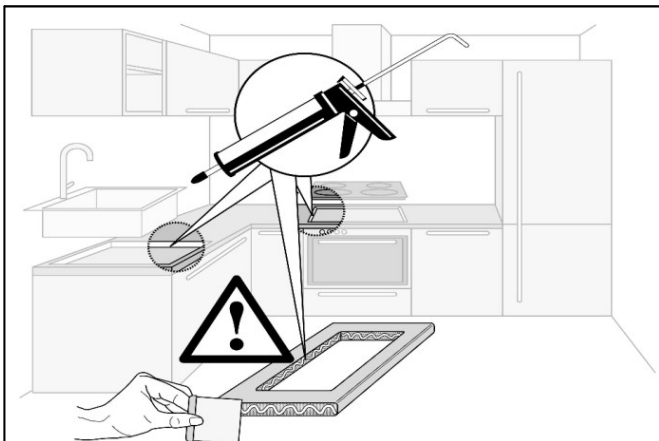
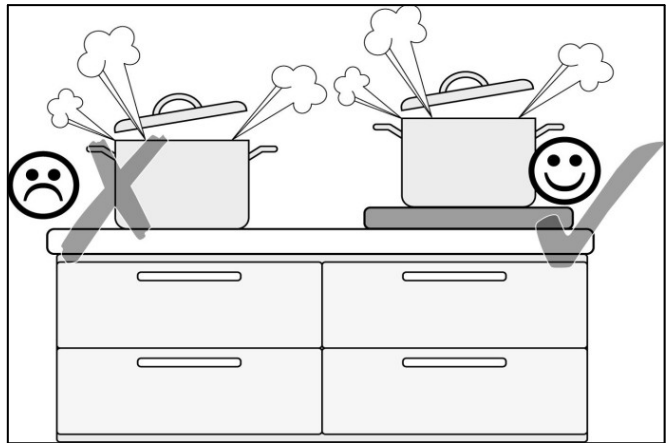
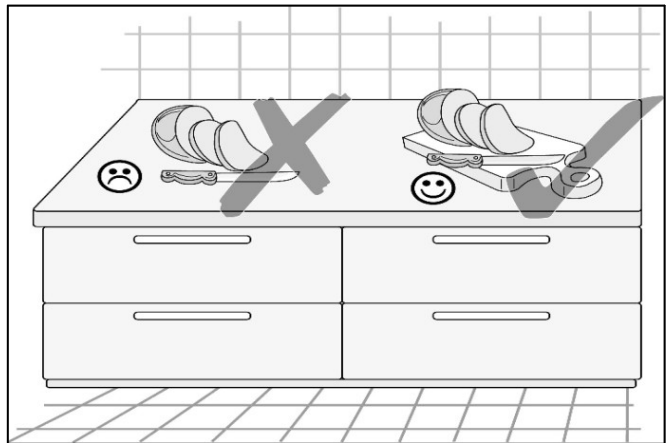
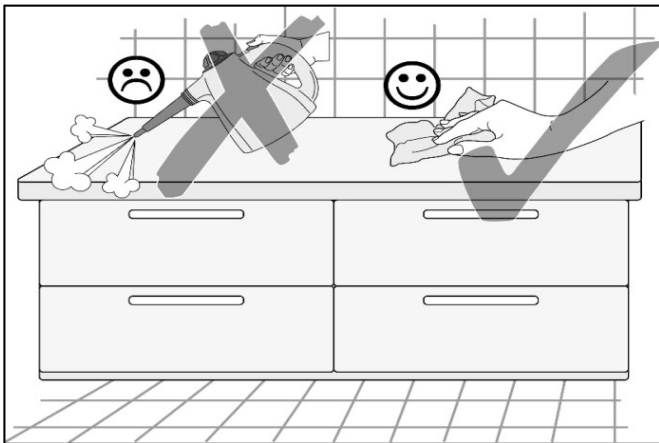
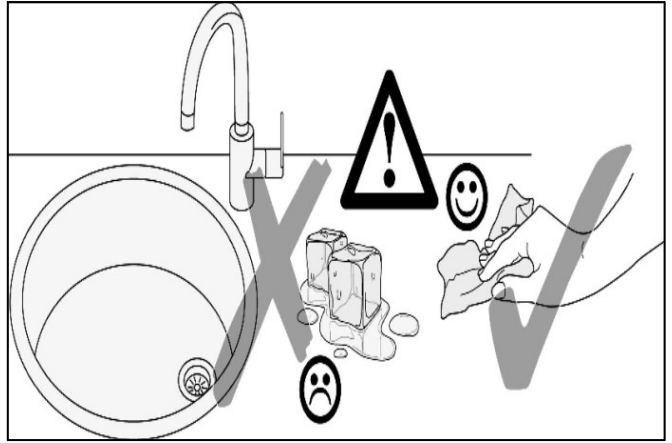
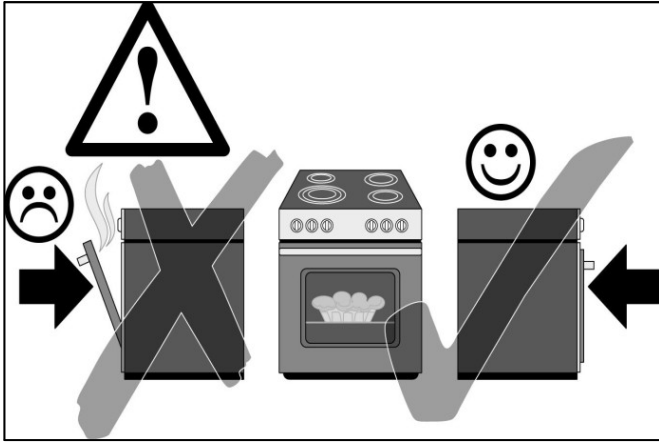

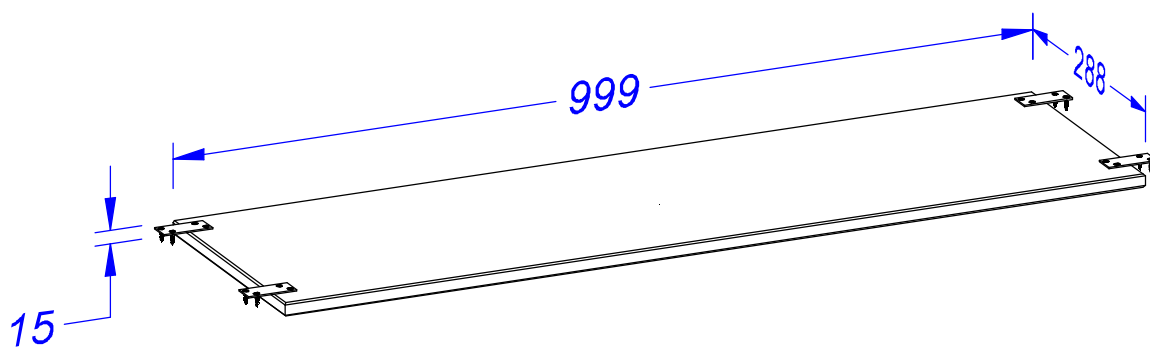

(D) *Montageanleitung*

(NL) *Handleiding voor de montage*

(TR) *Montaj talimatı*

(FR) *Notice de montage*

(CZ) *Montážní návod*

(HU) *Szerelési útmutató*

(GB) *Assembly instructions*

(PL) *Instrukcja montażu*

(RU) *Инструкция по монтажу*

(IT) *Istruzioni di montaggio*

(SK) *Návod na montáž*

(RO) *Instrucțiuni de montaj*

Name • Nom • Nome • Naam • Nazwa • Jméno •
Názov • Név • Denumire • Isim • Название

Nr. • No. • N° • Номер • Č • Sz

Typ • Type • Tip • Tipus • Tipo • Тип

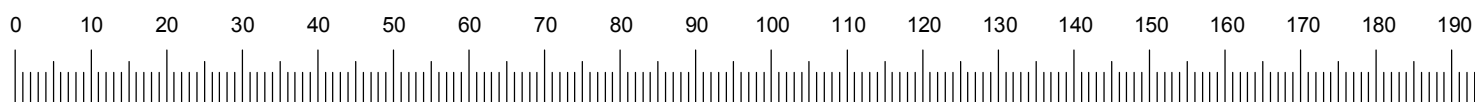
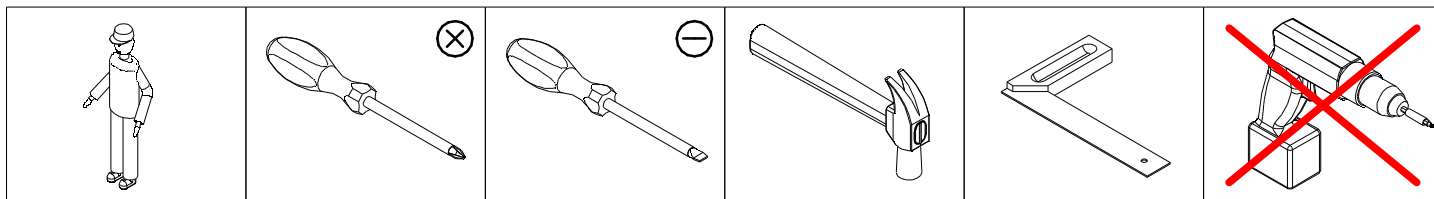
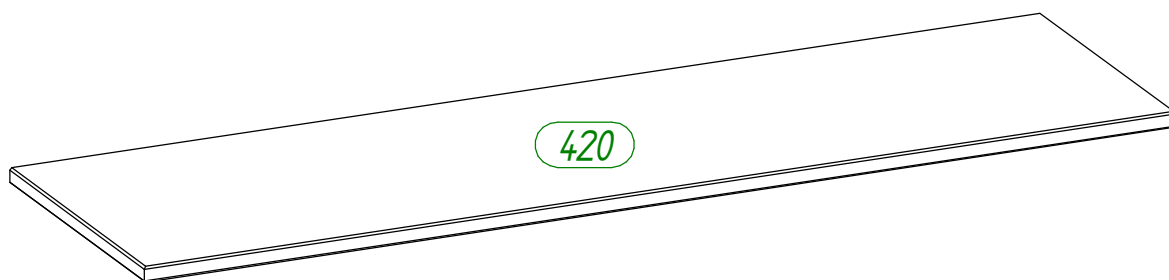
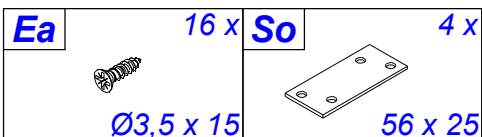
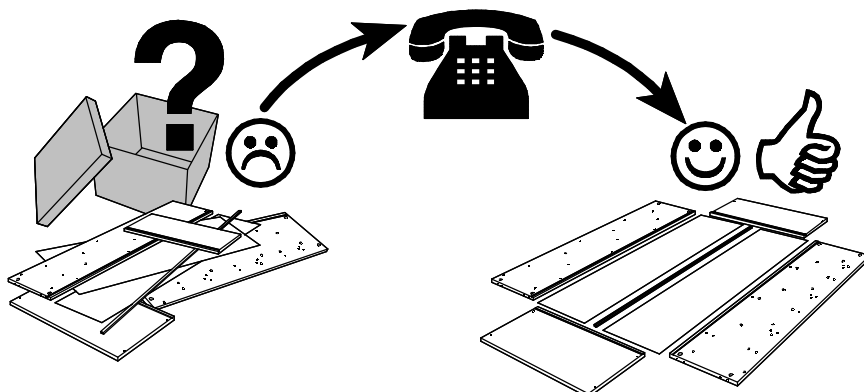
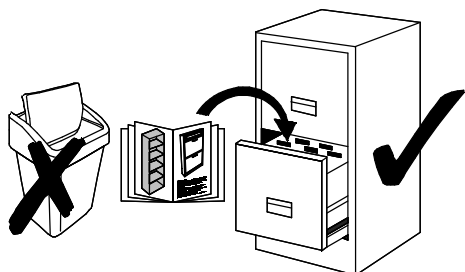

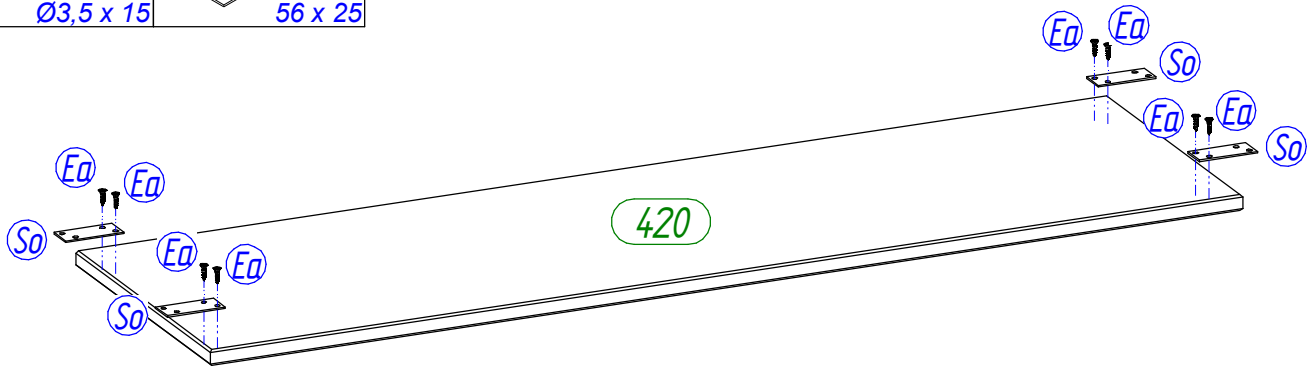
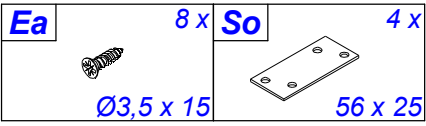
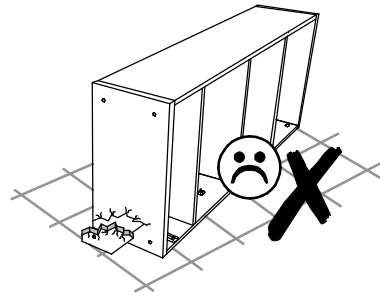
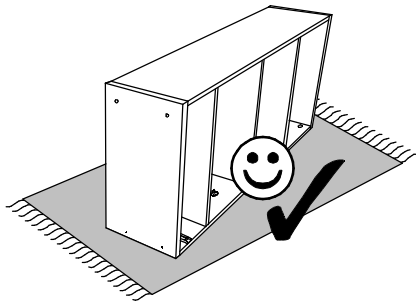

1

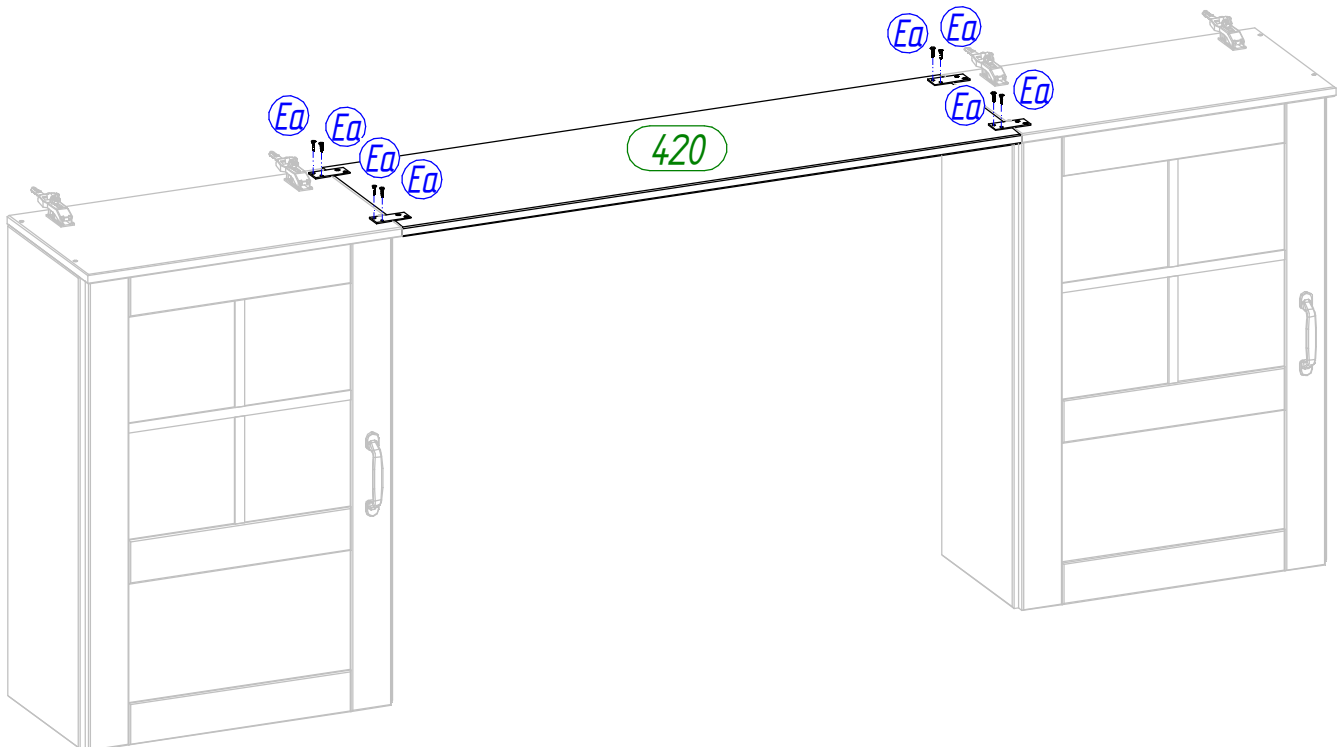
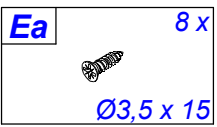

2