

- FR** NOTICE DE MONTAGE
- EN** ASSEMBLY INSTRUCTIONS
- DE** MONTAGEANLEITUNG
- ES** INSTRUCCIONES DE MONTAJE
- NL** MONTAGEVOORSCHRIFT
- IT** ISTRUZIONI DI MONTAGGIO
- PT** INSTRUÇÕES DE MONTAGEM
- PL** INSTRUKCJA MONTAŻU
- CR** NAPUTCI ZA MONTAŽU

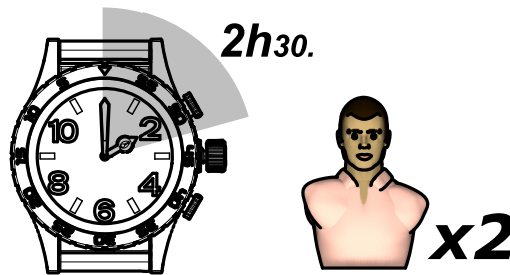

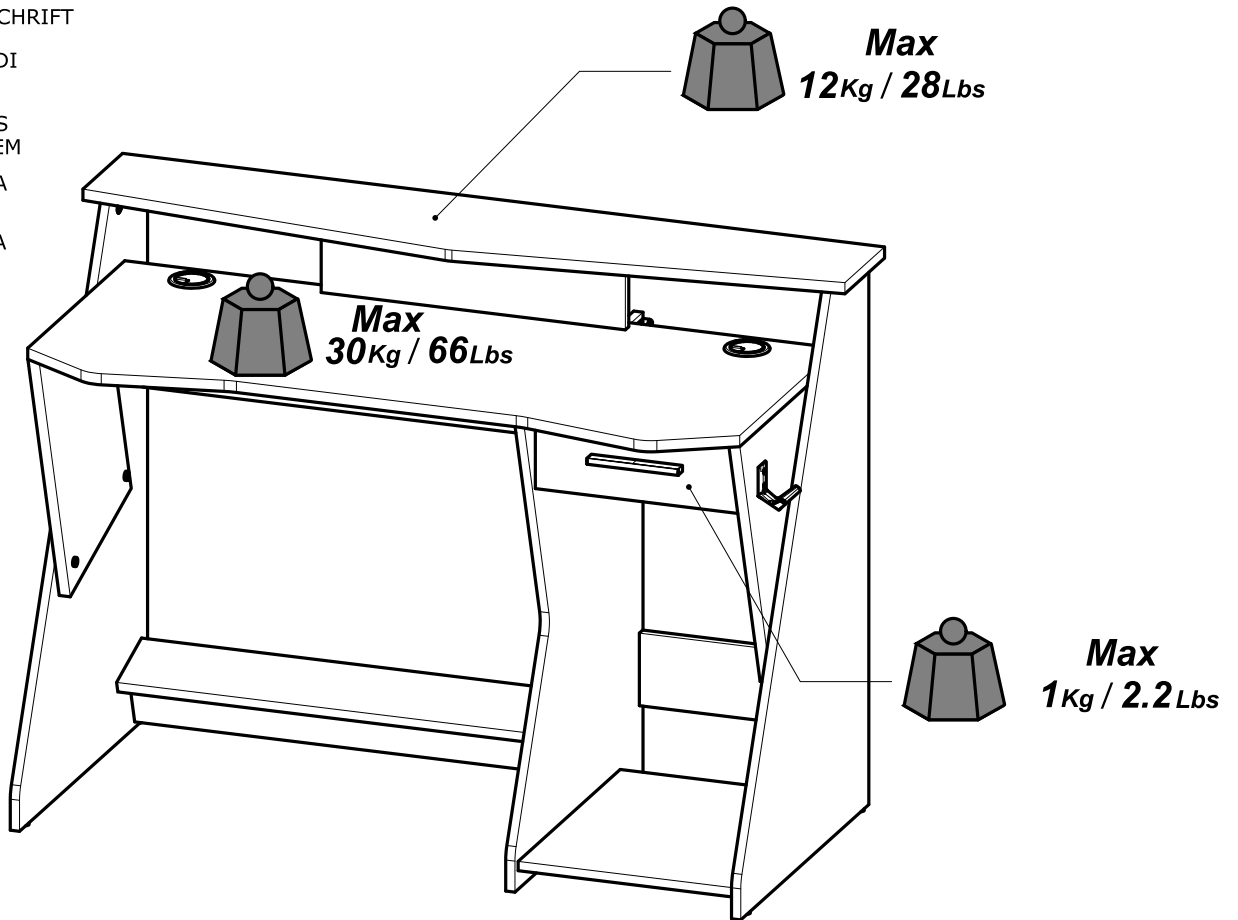
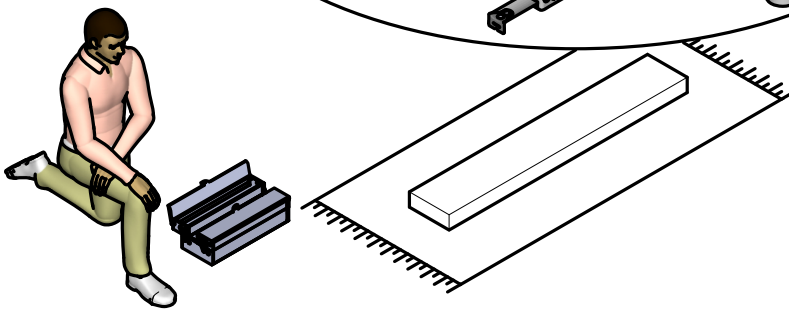
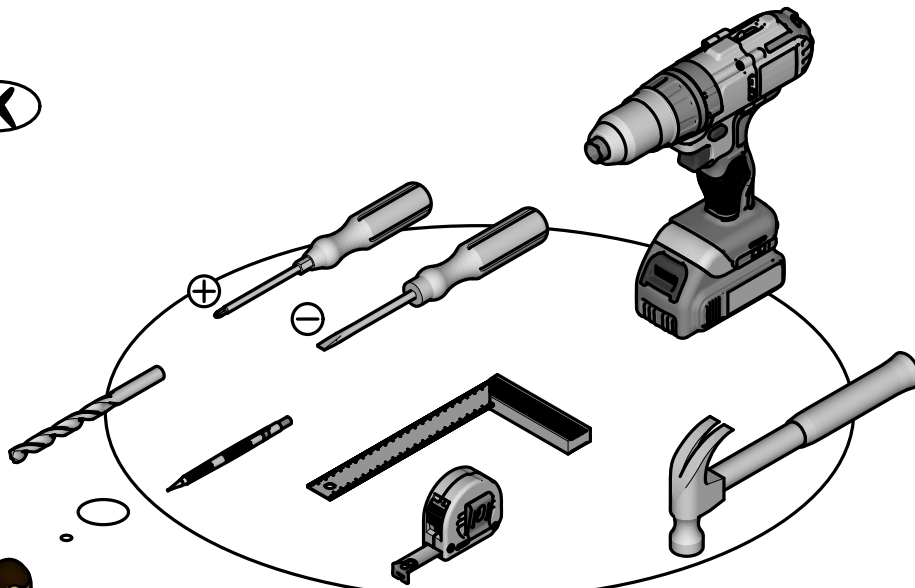
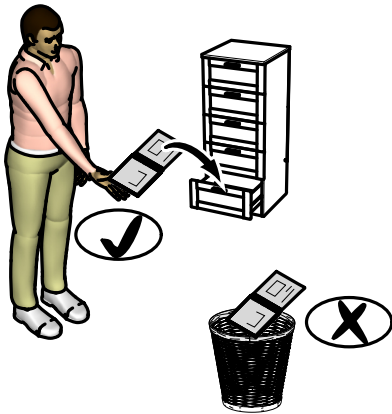
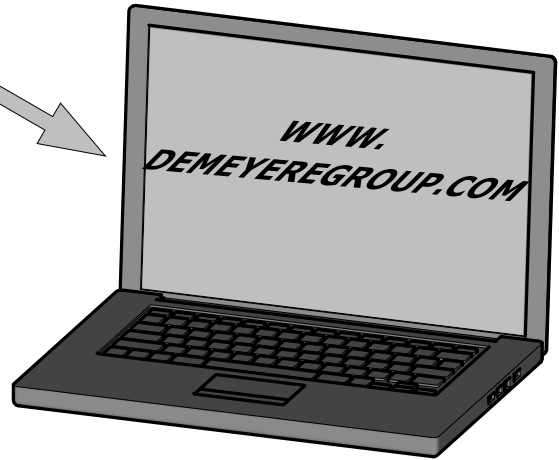
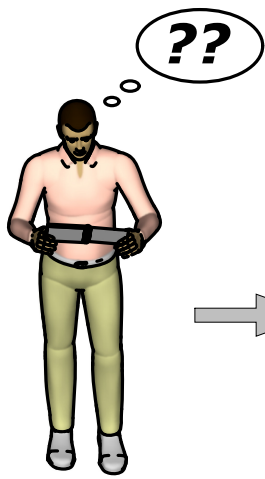

Donnez ou recyclez vos meubles.

Association

ou

Magasin

ou

Déchèterie

<https://www.demeyseregroup.com/fr>

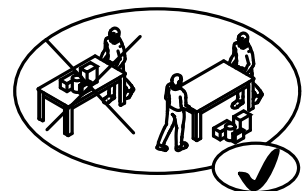
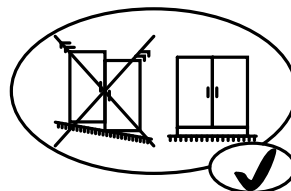
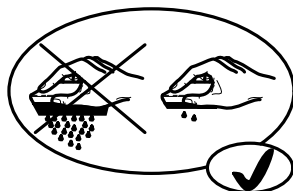
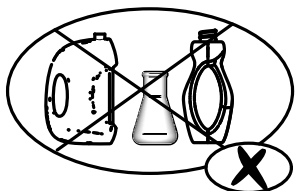



A x4



B x1

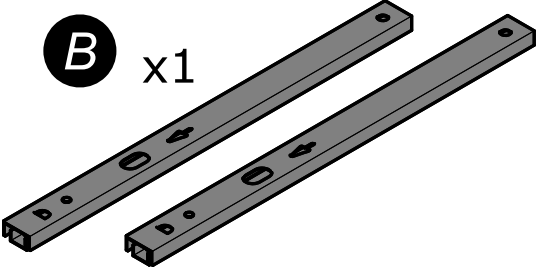

C x6



8x30mm
5/16" x 1 3/16"

D x12

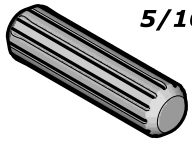

E x2



4x30mm
5/32" x 1 3/16"

F x1

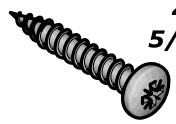

4x25mm
5/32" x 1"

G x4



6,3x9mm
1/4" x 11/32"

H x6

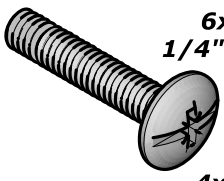

6x30mm
1/4" x 1 3/16"

I x2



4x9mm
5/32" x 11/32"

J x5



K x1

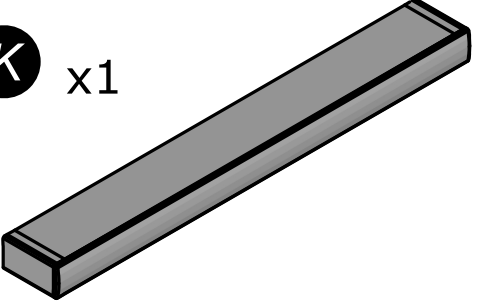

L x28



M x26



Ø15mm
Ø19/32"

N x1

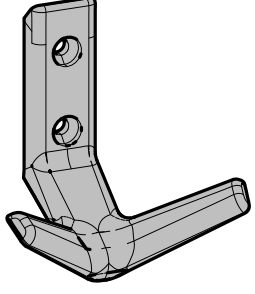

O x2

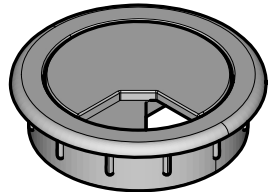

P x2

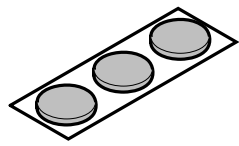

Q x4

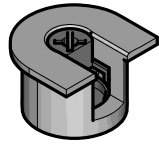

R x6



S x12

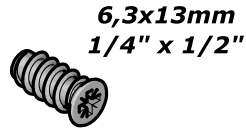

T x2

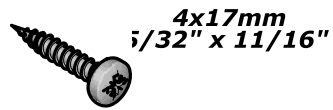

U x4

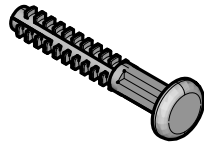

V x1

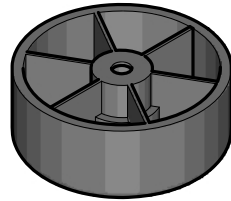

W x2

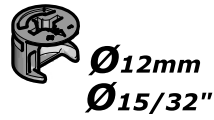

X x1

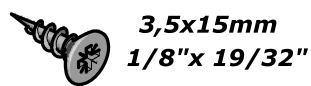

Y x1

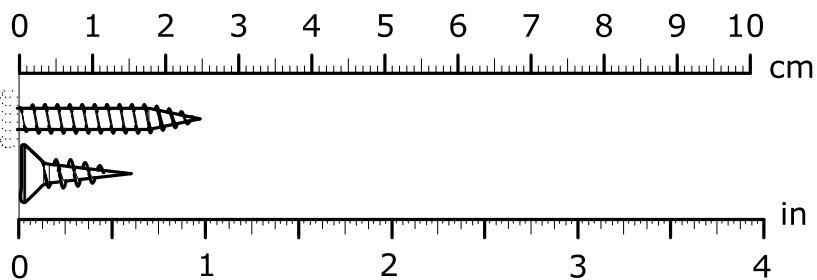
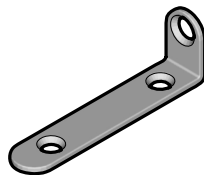

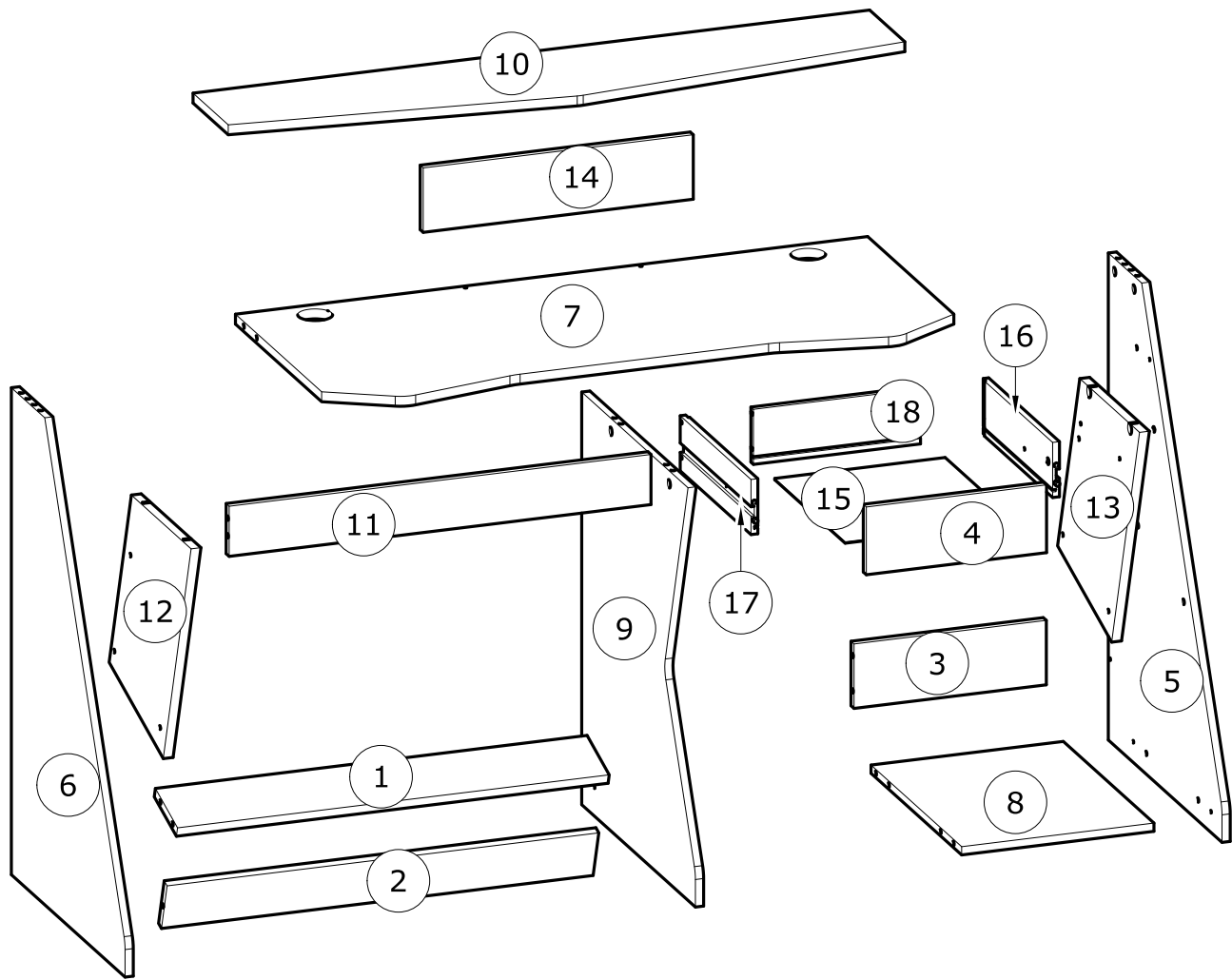

N°	MM		INCH		QTY
1	788	x 115	31	x 4 8/16	1
2	788	x 91	31	x 3 9/16	1
3	351	x 117	13 13/16	x 4 10/16	1
4	329	x 123	12 15/16	x 4 13/16	1
5	884	x 562	34 13/16	x 22 2/16	1
6	884	x 562	34 13/16	x 22 2/16	1
7	1 154	x 498	45 7/16	x 19 10/16	1
8	351	x 448	13 13/16	x 17 10/16	1
9	749	x 562	29 8/16	x 22 2/16	1

N°	MM		INCH		QTY
10	1 235	x 242	48 10/16	x 9 8/16	1
11	770	x 91	30 5/16	x 3 9/16	1
12	448	x 281	17 10/16	x 11 1/16	1
13	448	x 281	17 10/16	x 11 1/16	1
14	493	x 117	19 7/16	x 4 10/16	1
15	311	x 348	12 4/16	x 13 11/16	1
16	350	x 100	13 12/16	x 3 15/16	1
17	350	x 100	13 12/16	x 3 15/16	1
18	305	x 100	12	x 3 15/16	1

FR

AVERTISSEMENT : MEUBLE A FIXER IMPERATIVEMENT AU MUR AFIN D'EVITER SON BASCULEMENT

- Pour installer correctement ce produit et éliminer les risques pour votre sécurité, merci de suivre exactement ce manuel d'instruction.
- Fixer le meuble au mur avec les attaches prévues à cet effet
- Les vis et les chevilles ne sont pas fournies. Utiliser des vis et des chevilles adaptées au support.

EN

WARNING: FURNITURE TO BE ATTACHED TO THE WALL TO PREVENT OVERTURNING

- Installation shall be carried out exactly according to those instructions-otherwise a safety risk can occur if incorrectly installed;
- Attach the furniture to the wall with the fastening provided for this purpose
- Screw and Pegs are not supplied. Use Screws and pegs adapted to the support.

DE

WARNUNG: DAS MÖBEL MUSS AN DER WAND BEFESTIGT WERDEN, UM ZU VERHINDEN DASS ES KIPPT

- Um das Produkt korrekt zu installieren und um Risiken für Ihre Sicherheit zu verhindern, die Gebrauchsanleitung genauestens befolgen.
- Das Möbel mit den vorgesehenen Befestigungen an einer Wand befestigen.
- Schrauben und Dübel sind nicht im Lieferumfang enthalten. Passende Schrauben und Dübel verwenden.

ES

ADVERTENCIA: ESTE MUEBLE DEBE ESTAR SIEMPRE FIJO EN LA PARED PARA EVITAR QUE VUELQUE

- Para instalar correctamente este producto y eliminar los riesgos para la seguridad, seguir exactamente las instrucciones del manual.
- Fijar el mueble a la pared con las sujeciones previstas a este efecto.
- Los tornillos y los tacos no están incluidos. Utilizar tornillos y tacos adaptados al soporte.

NL

WAARSCHUWING: MEUBEL MOET VERPLICHT AAN DE MUUR BEVESTIGD WORDEN ZODAT HET NIET KAN OMVALLEN

- Om dit product correct te installeren en alle risico's voor uw veiligheid te elimineren, gelieve de instructies in deze handleiding nauwgezet op te volgen.
- Zet het meubel vast aan de muur met de hiertoe voorziene bevestigingen.
- De schroeven en pluggen zijn niet meegeleverd. Gebruik schroeven en pluggen die geschikt zijn voor het materiaal van de muur.

IT

AVVERTENZA: MOBILE DA FISSARE IMPERATIVAMENTE AL MURO PER EVITARE CHE SI RIBALTI

- Per installare correttamente questo prodotto ed eliminare i rischi per la vostra sicurezza, si prega di seguire esattamente il manuale d'istruzioni.
- Fissare il mobile al muro con gli appositi ganci.
- Le viti e i tasselli non sono forniti. Utilizzare viti e tasselli adatti al supporto.

PT

ADVERTÊNCIA: MÓVEL A FIXAR OBRIGATORIAMENTE À PAREDE PARA EVITAR A SUA QUEDA

- Para instalar corretamente este produto e eliminar os riscos para a sua segurança, é favor seguir exatamente este manual de instruções.
- Fixe o móvel à parede com as fixações previstas para o efeito
- Os parafusos e as cavilhas não são fornecidos. Utilize parafusos e cavilhas adaptados ao suporte.

PL

OSTRZEŻENIE: MEBEL NALEŻY PRZYMOCOWAĆ DO ŚCIANY, ABY UNIKNĄĆ JEGO PRZEWRÓCENIA

- Aby prawidłowo zainstalować ten produkt i wyeliminować zagrożenie dla bezpieczeństwa użytkownika, należy postępować zgodnie z niniejszą instrukcją.
- Przymocować mebel do ściany za pomocą mocowań przewidzianych w tym celu.
- Śruby i nakrętki nie znajdują się w zestawie. Użyć śrub i nakrętek dostosowanych do wspornika.

CR

UPOZORENJE : UČVRSTITE ORMARIĆ NA ZID KAKO BISTE SPRIJEČILI NJEGOVO LJULJANJE

- Kako biste pravilno postavili ovaj proizvod i uklonili sigurnosne rizike kojima se izlažete, pridržavajte se strogo ovog priručnika s uputama.
- Postavite ormarić na zid pripadajućim sponama.Vijci i svornjci ne isporučuju se. Upotrijebite nosne vijke i svornjke.

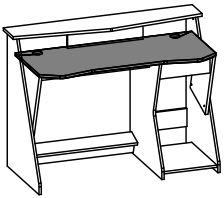

1

A x4



D x2

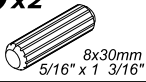

L x2

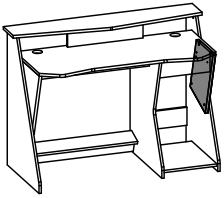
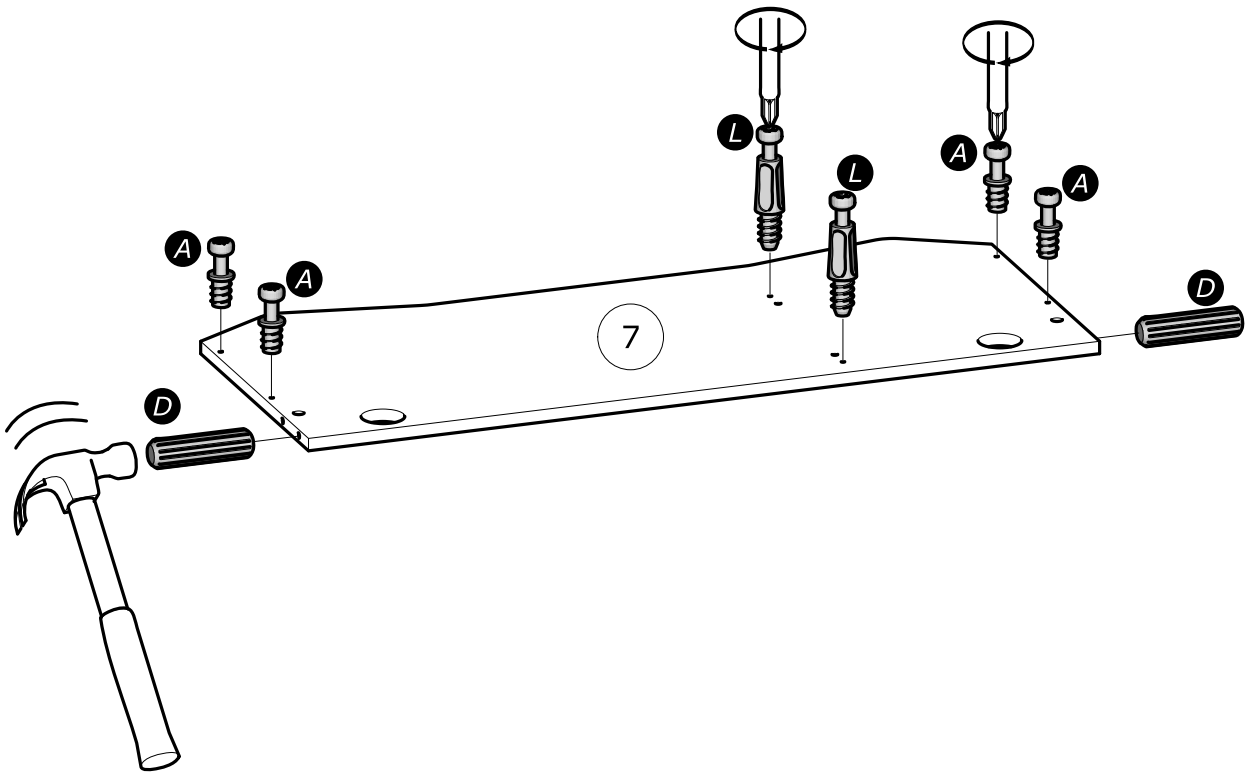
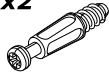

2

B x1

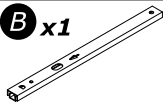

G x2

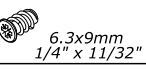

Q x2

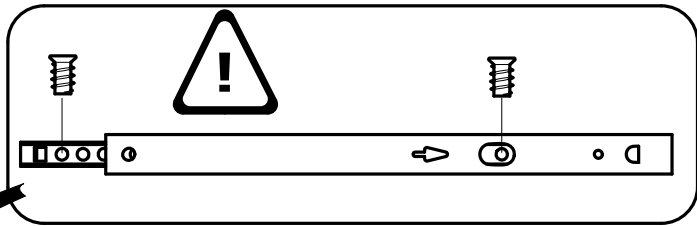
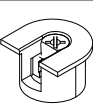

www.Demeyere.fr

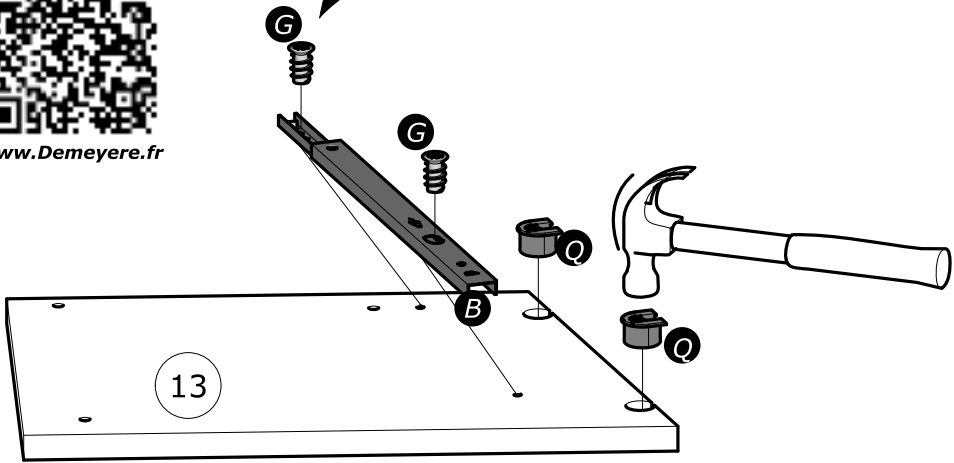
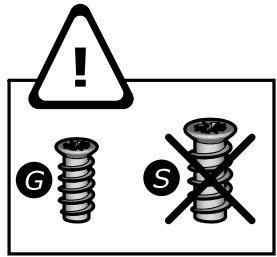

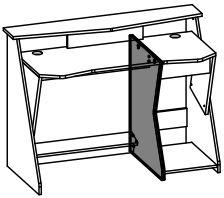

3

B x1

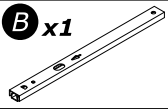

D x2

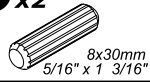

G x2

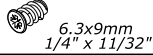

L x4

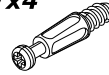

www.Demeyere.fr

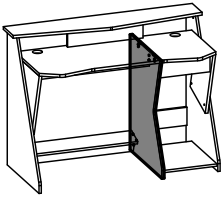
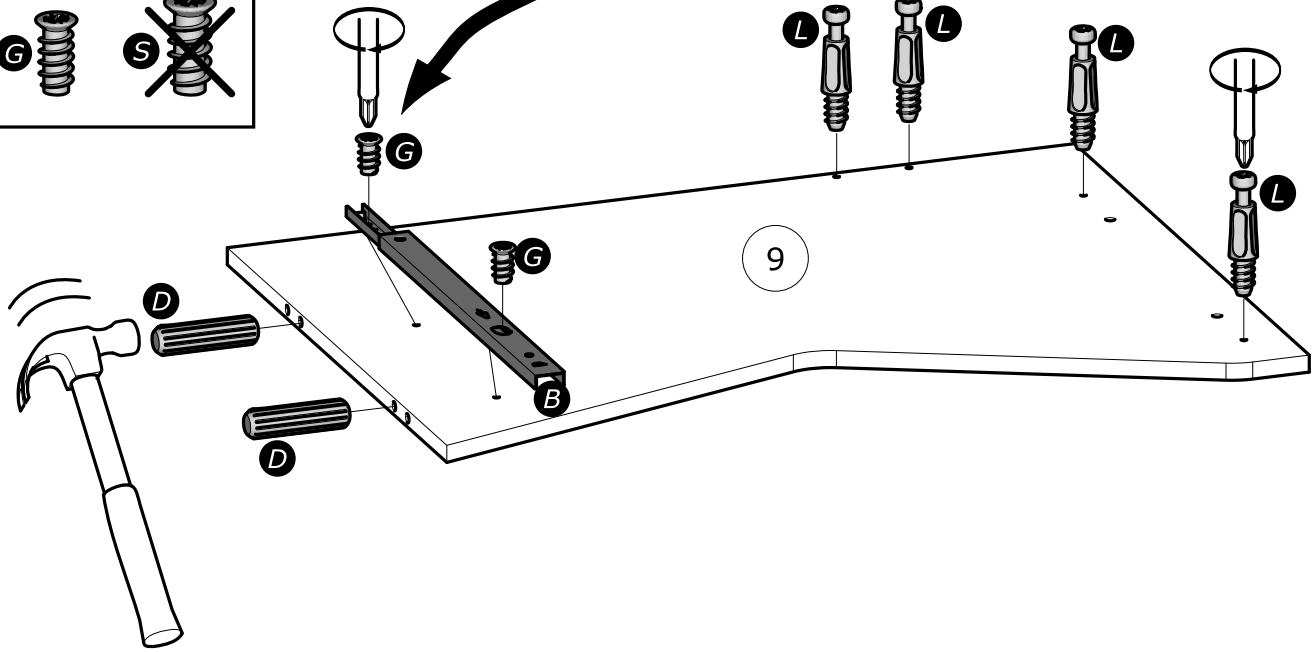
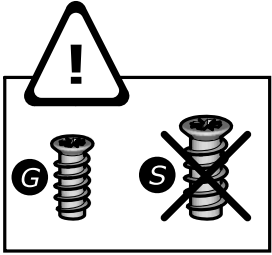
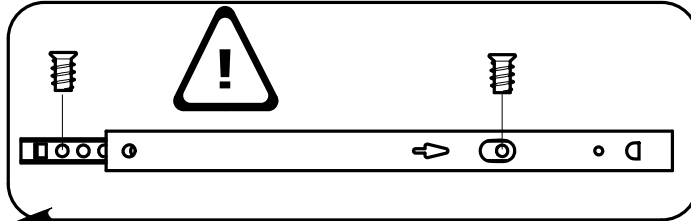

4

L x5

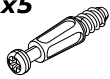

P x1

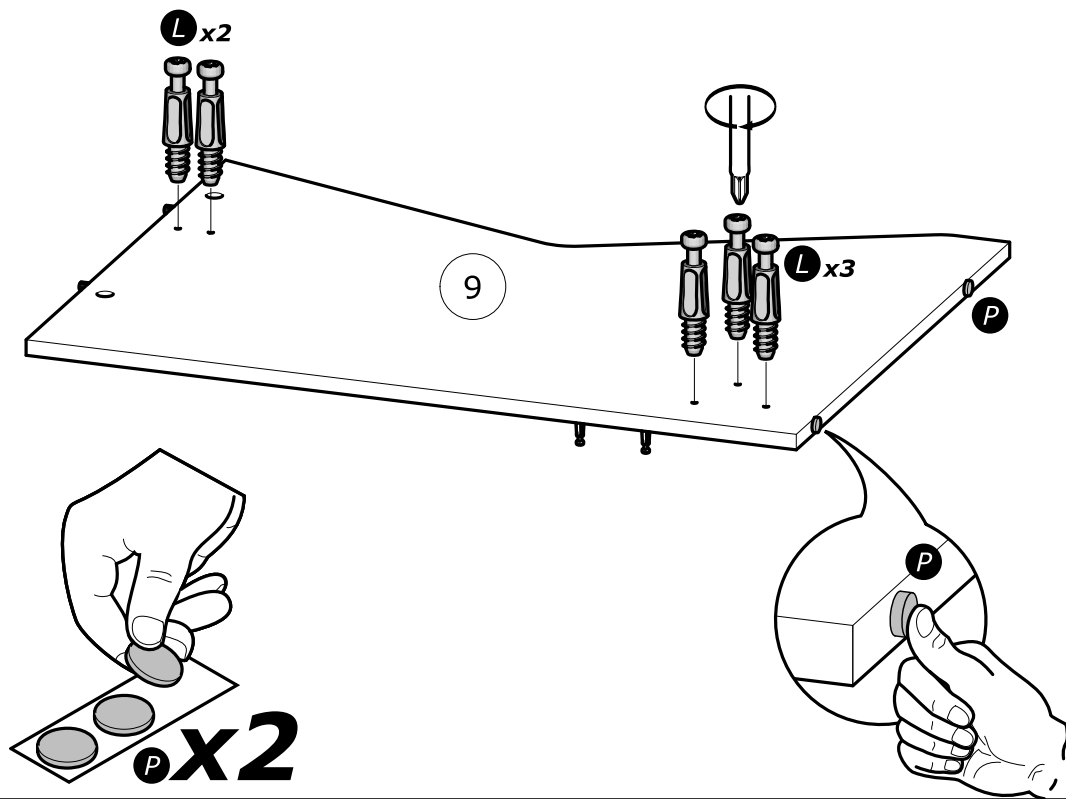

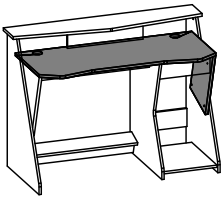

5

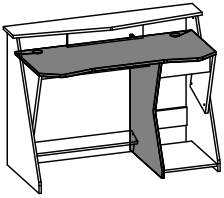
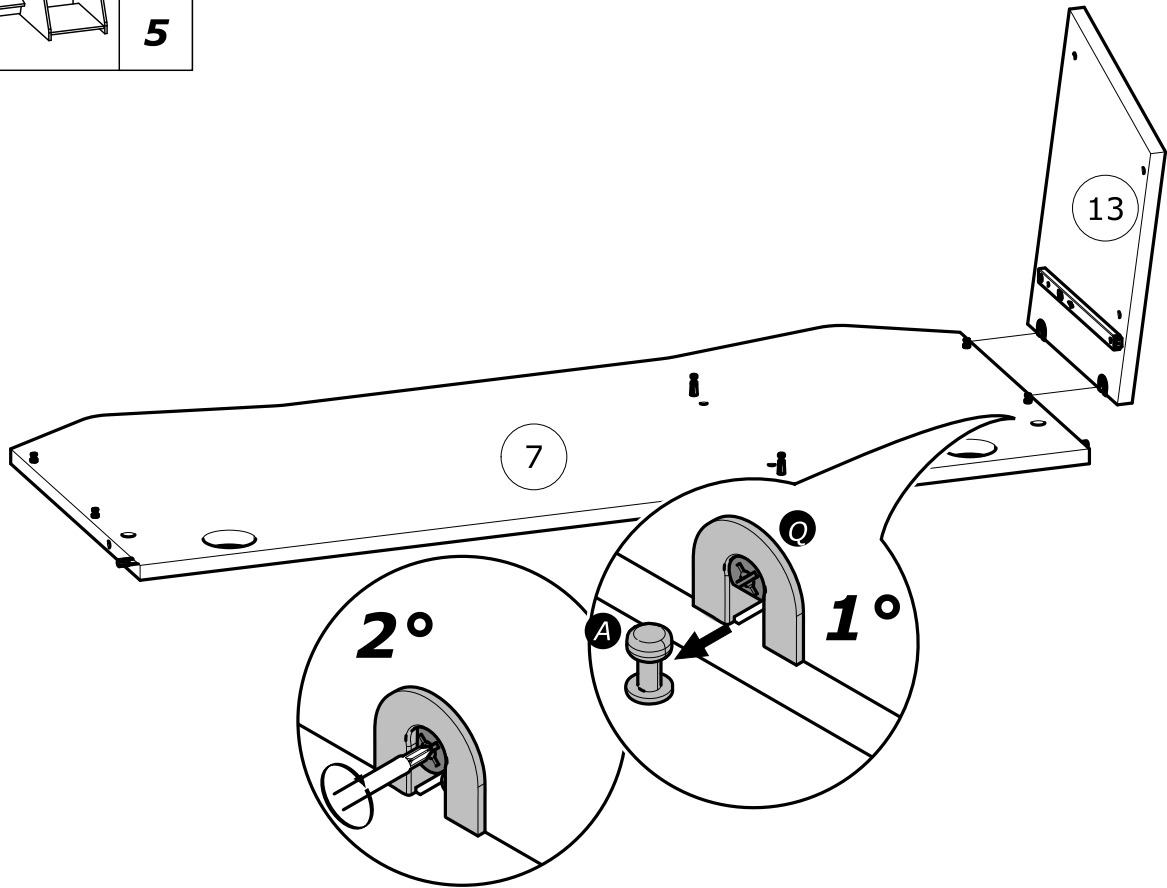

6

M x2
Ø15mm
Ø19/32"

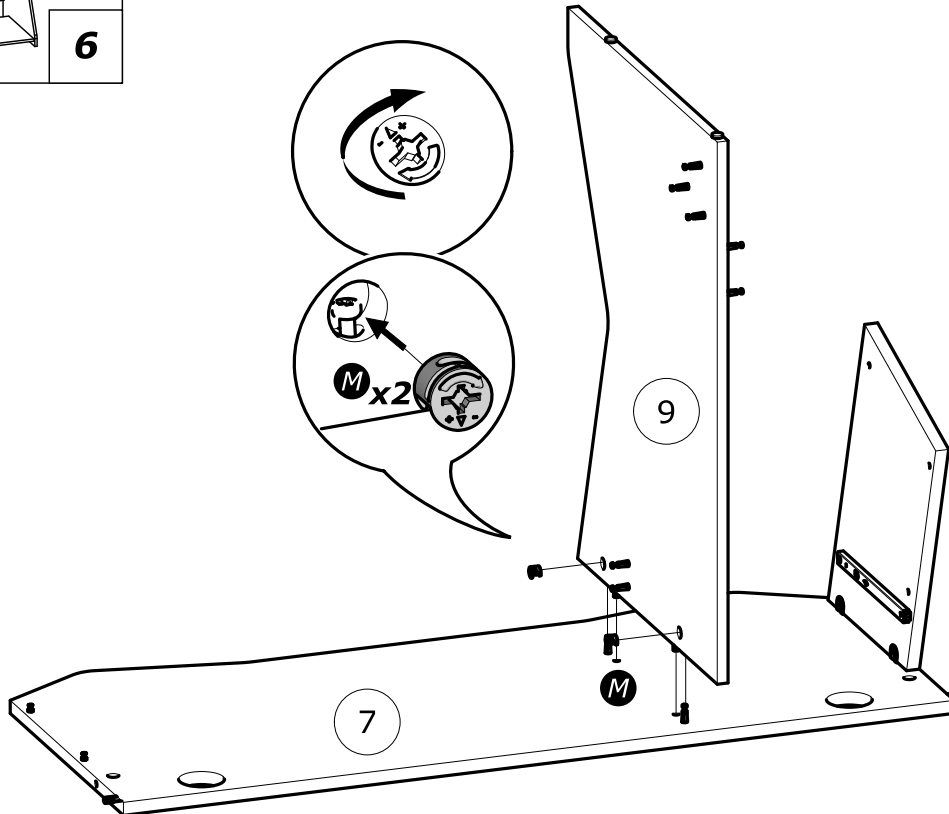

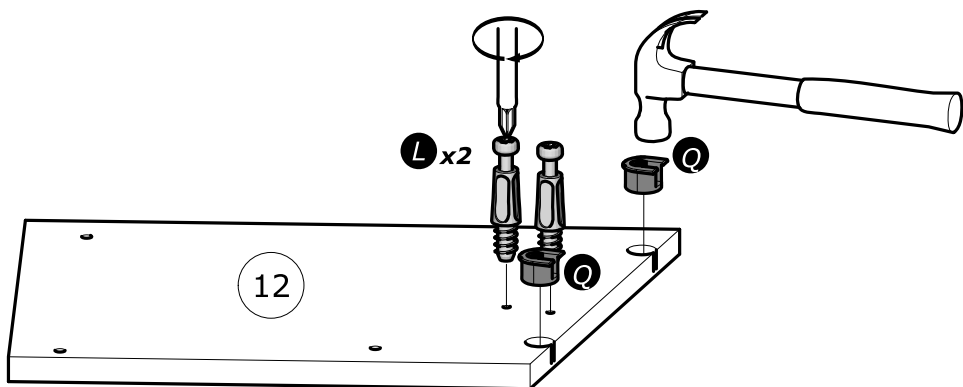
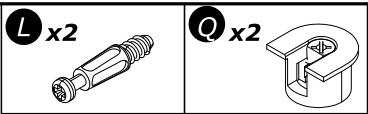
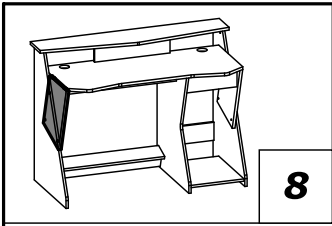
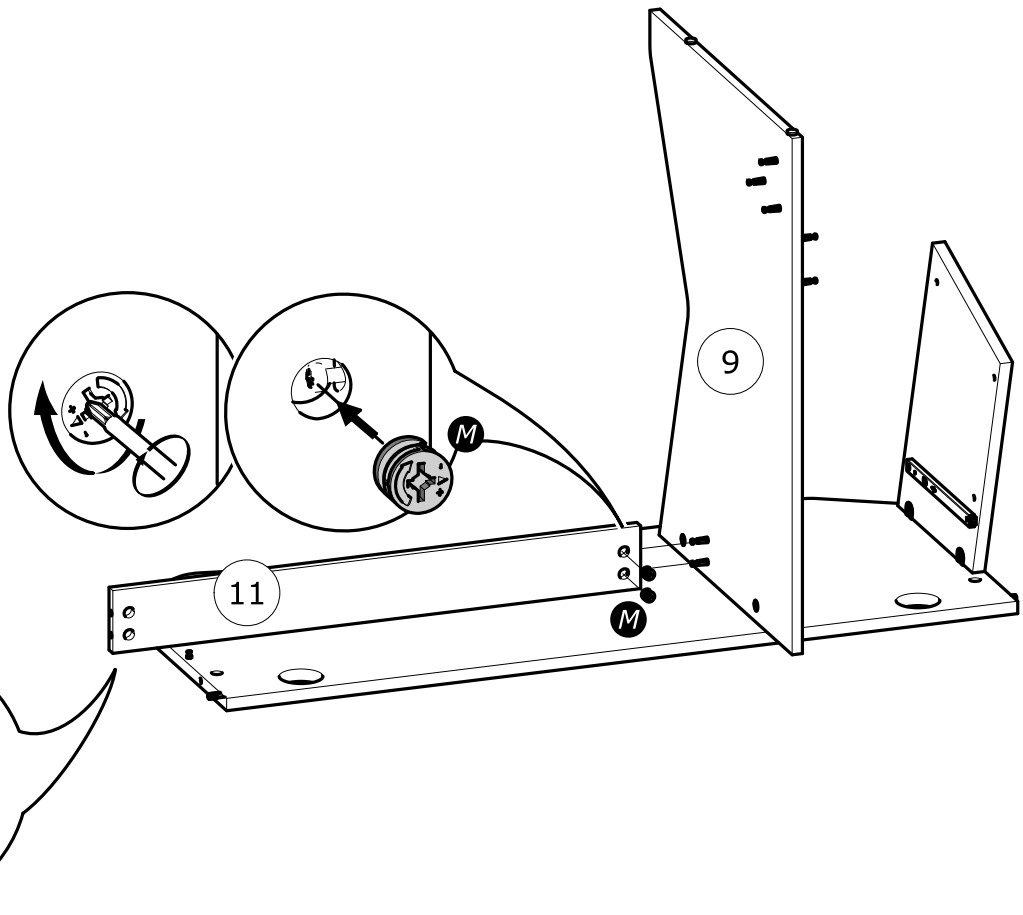
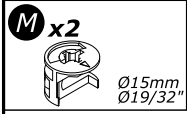
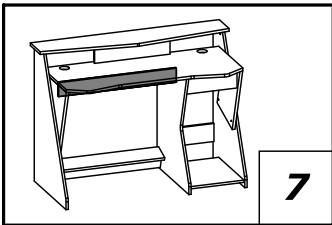

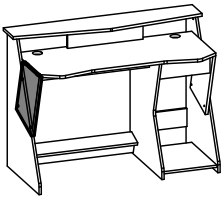

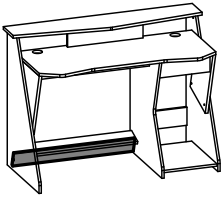
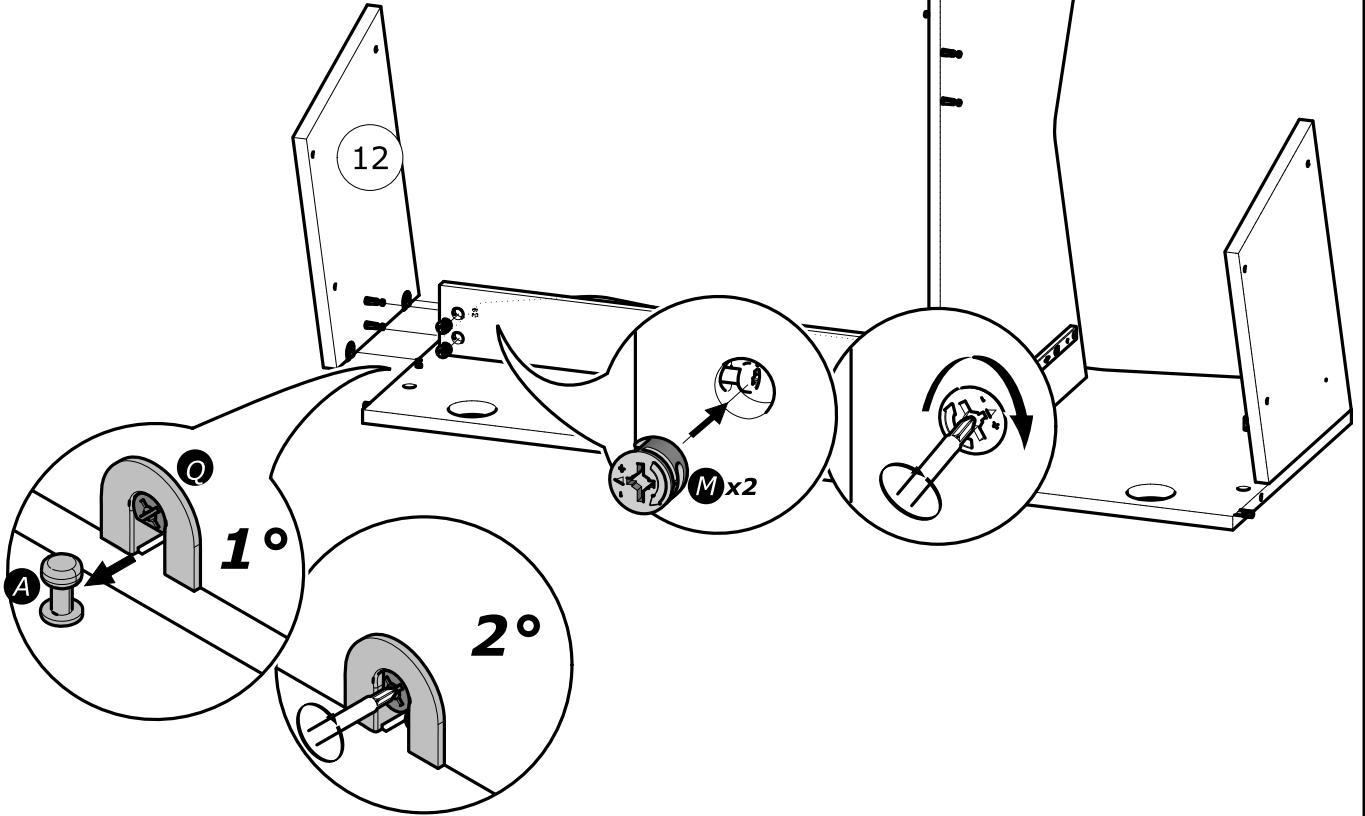

9

M x2
 Ø15mm
Ø19/32"



10

R x2

S x2
 6.3x13mm
1/4" x 1/2"

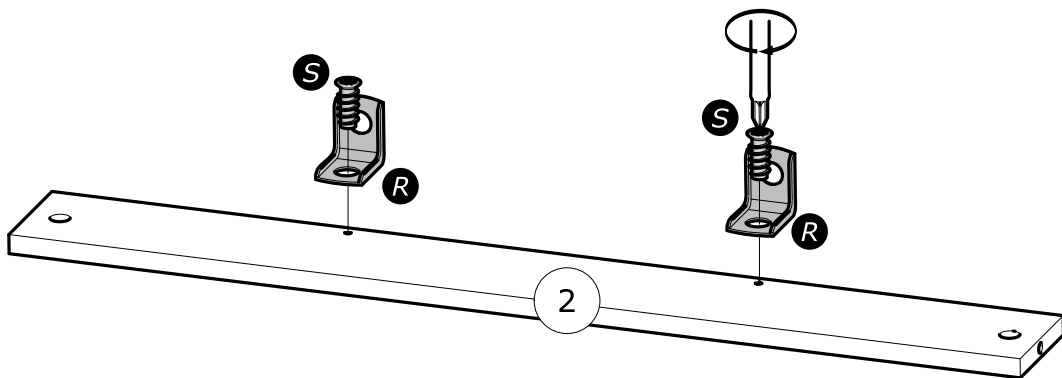

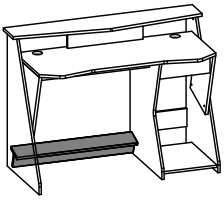

11

S x2



6.3x13mm,
1/4" x 1/2"

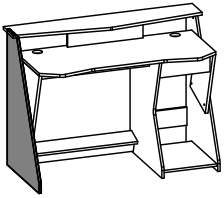
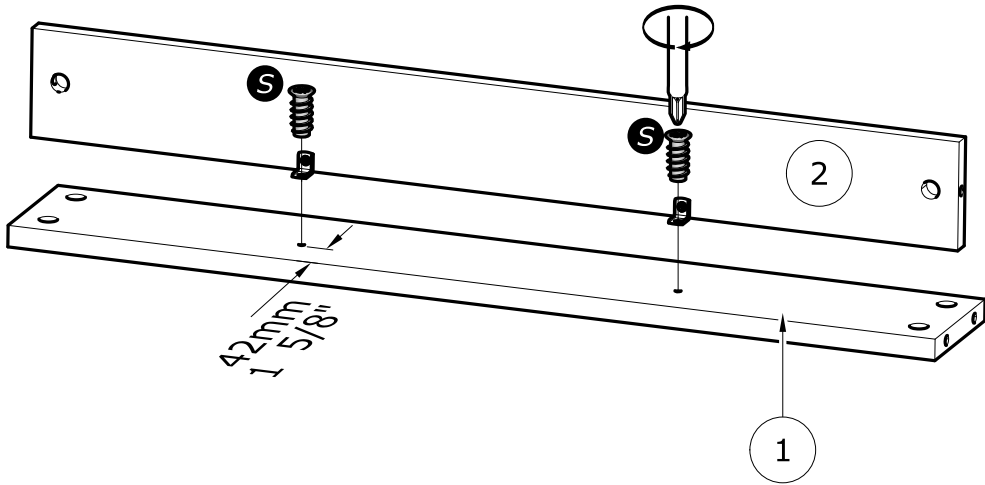

12

C x3



D x2

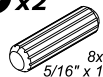

8x30mm
5/16" x 1 3/16"

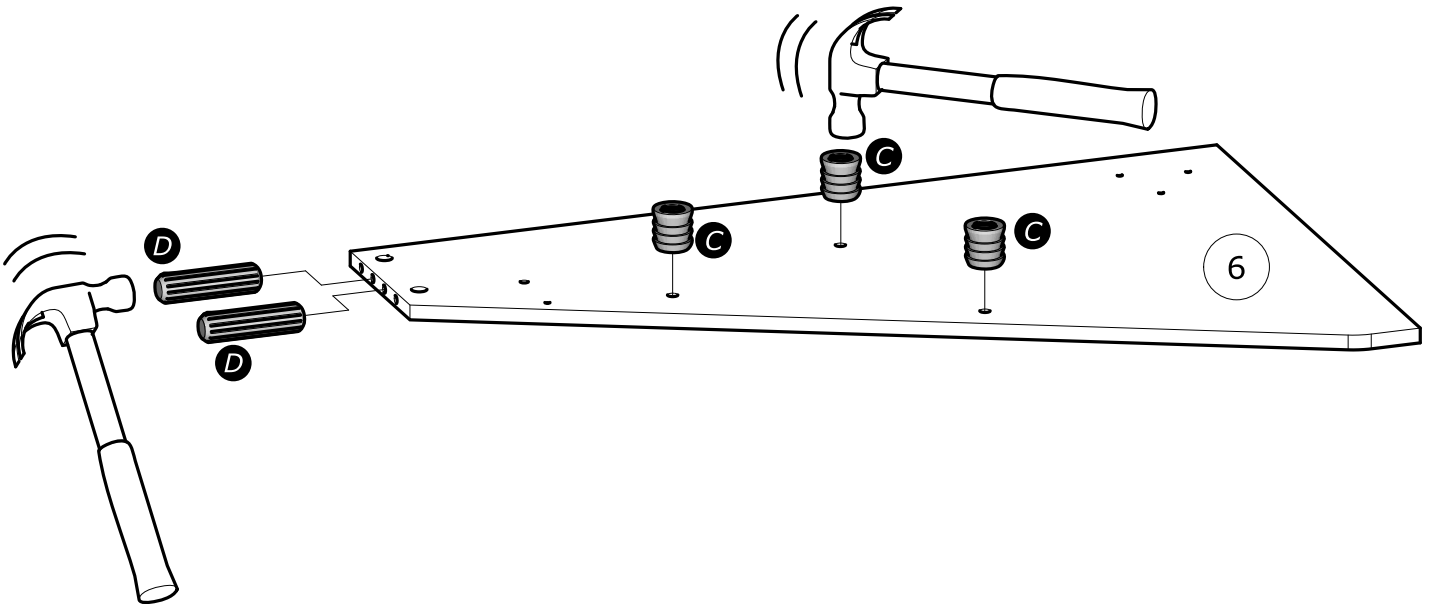
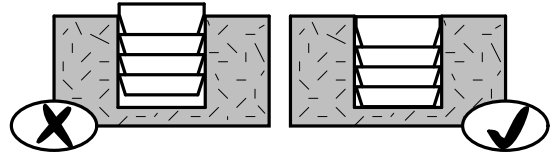

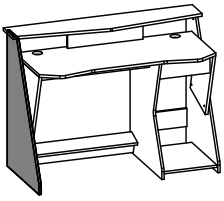

13

L x4

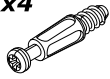

P x1

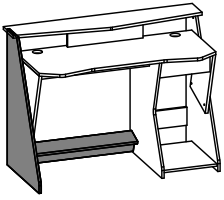
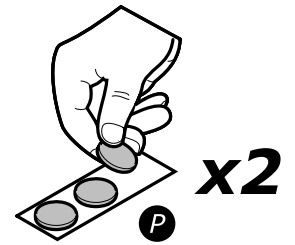
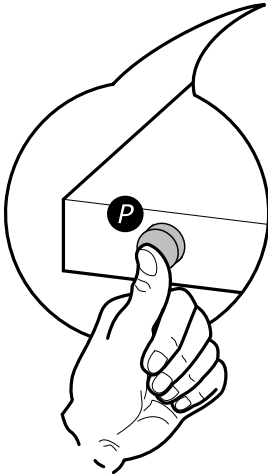
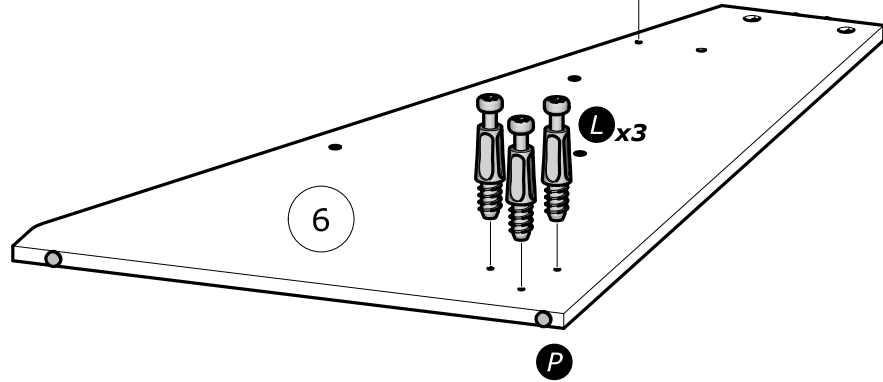
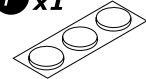

14

M x3



Ø15mm,
Ø19/32"

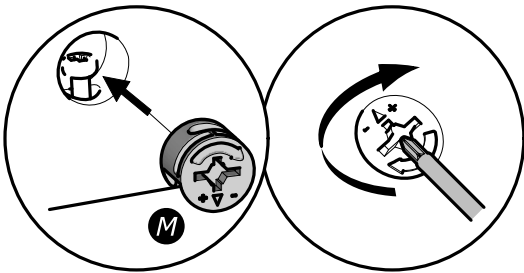

x3

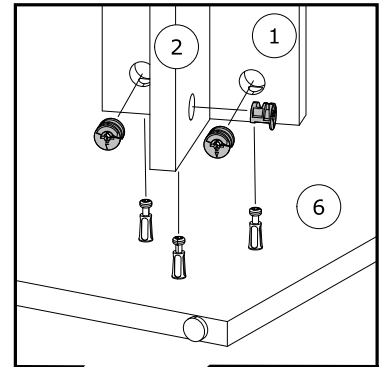
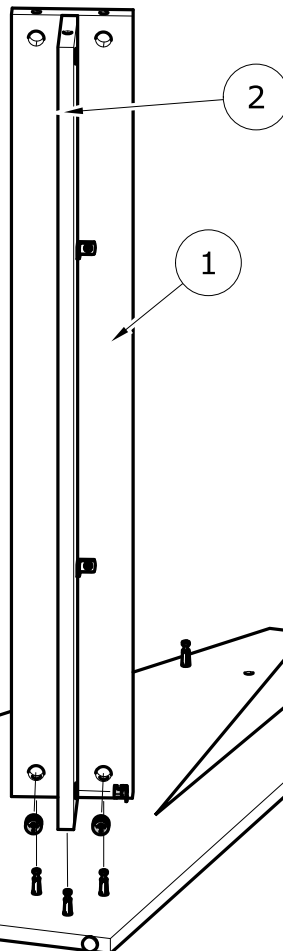

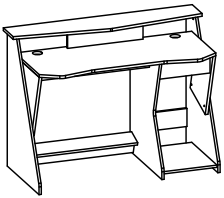

15

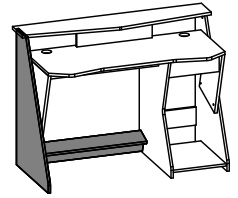
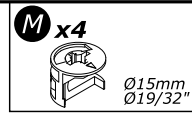
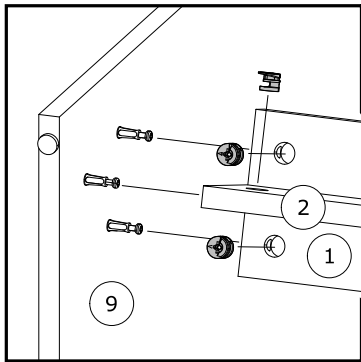
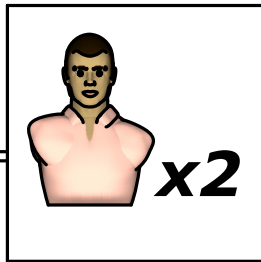
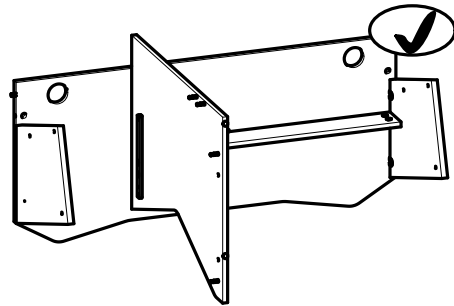
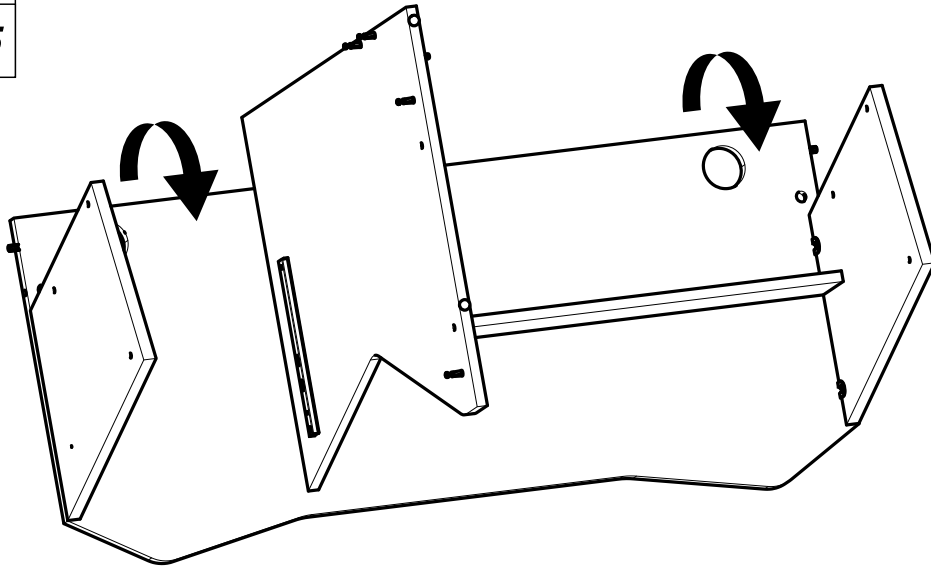

16

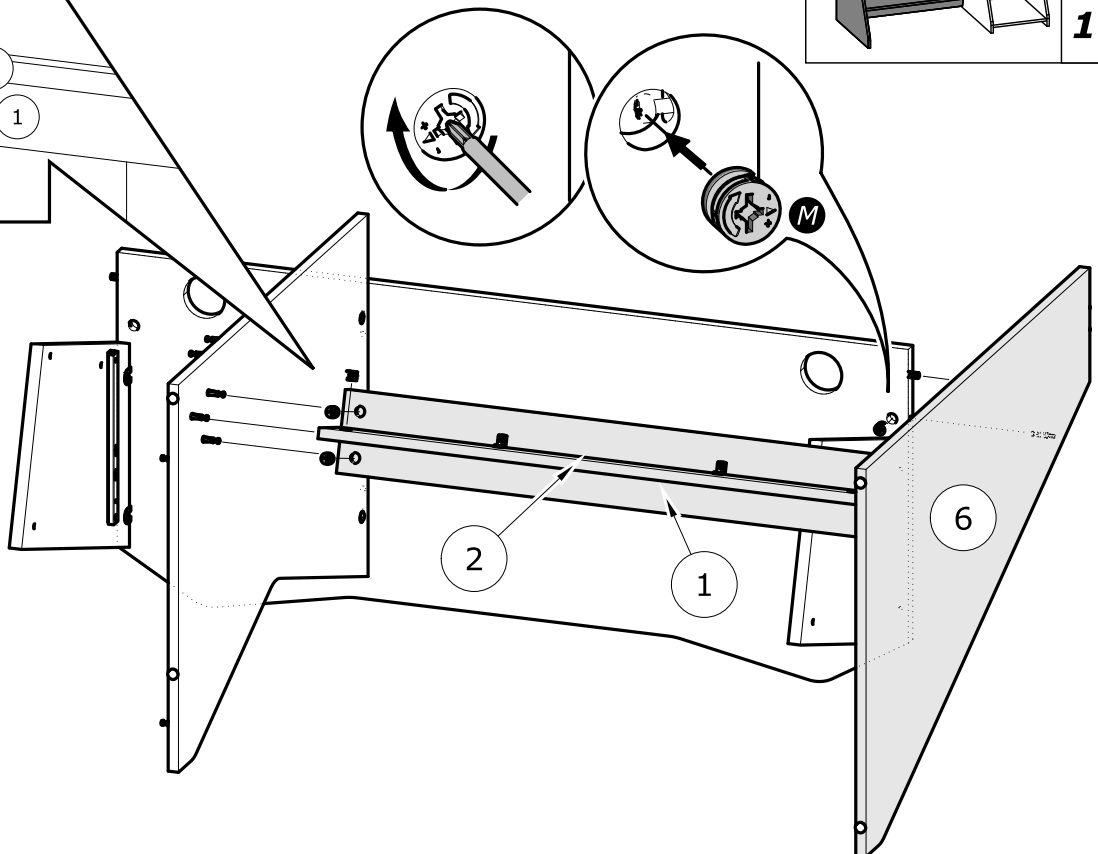
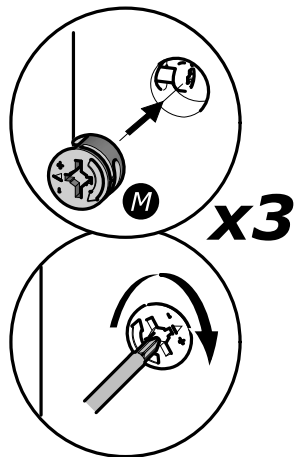

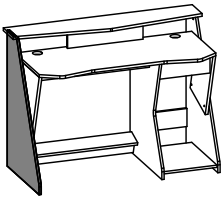

17

H x3
6x30mm
1/4" x 1 3/16"

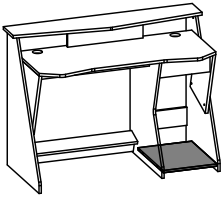
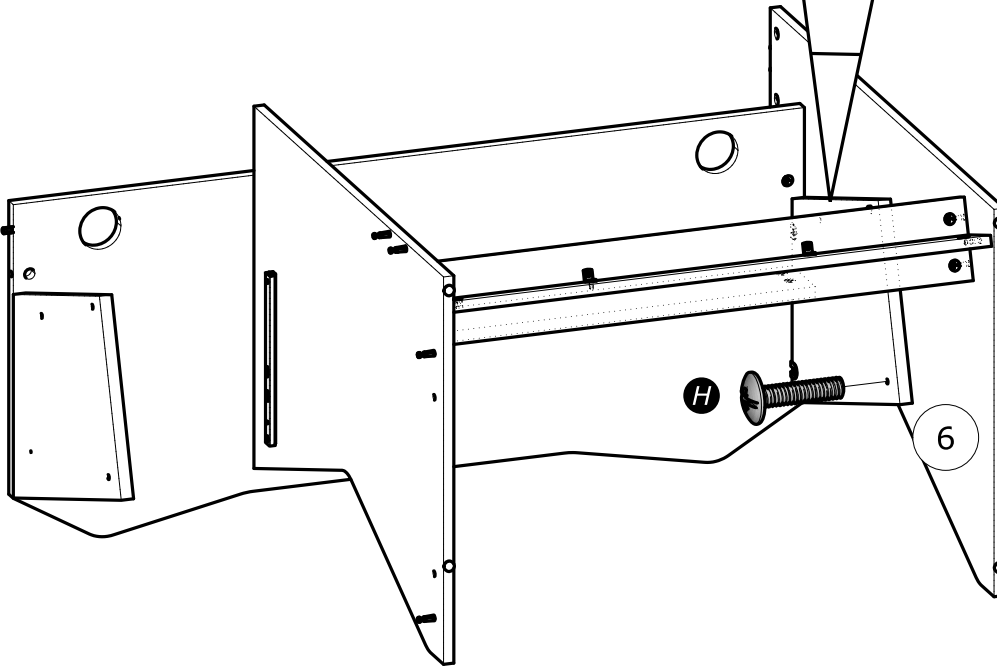
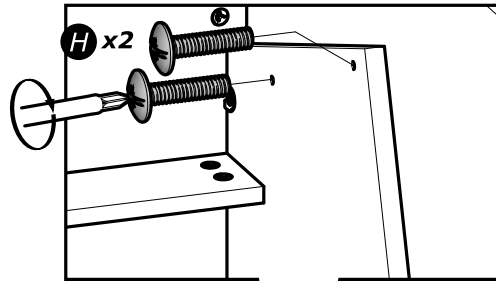

18

D x4
8x30mm
5/16" x 1 3/16"

F x1
4x25mm
5/32" x 1"

V x1

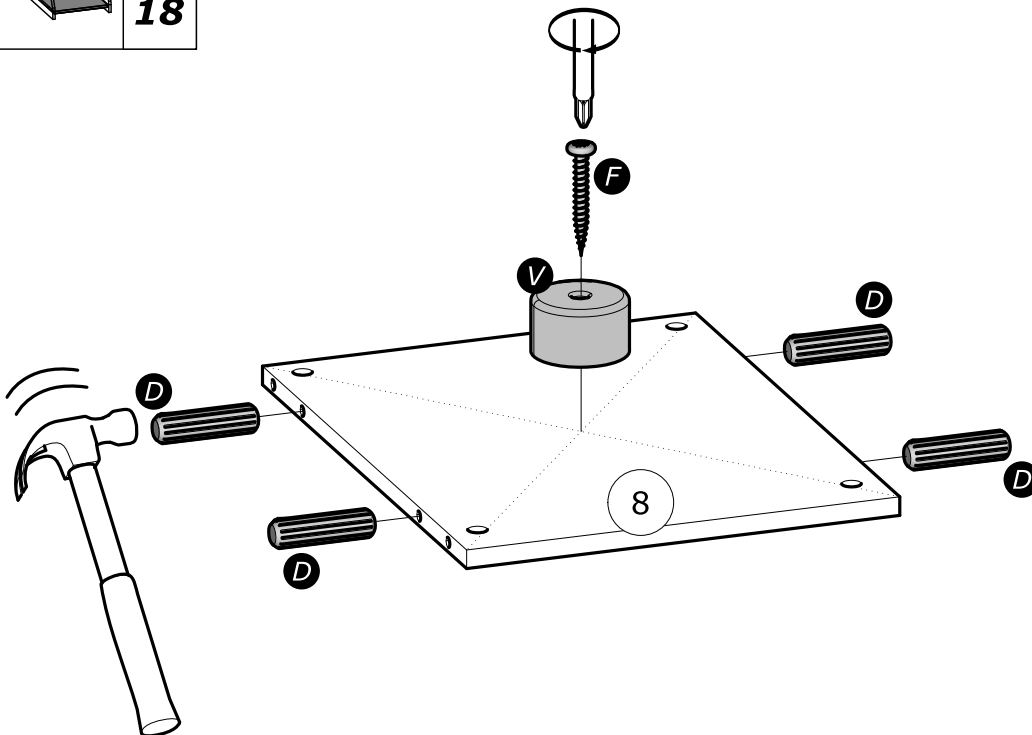

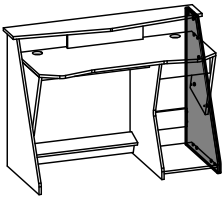

19

D x2
8x30mm
5/16" x 1 3/16"

C x3

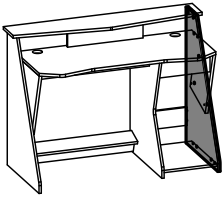
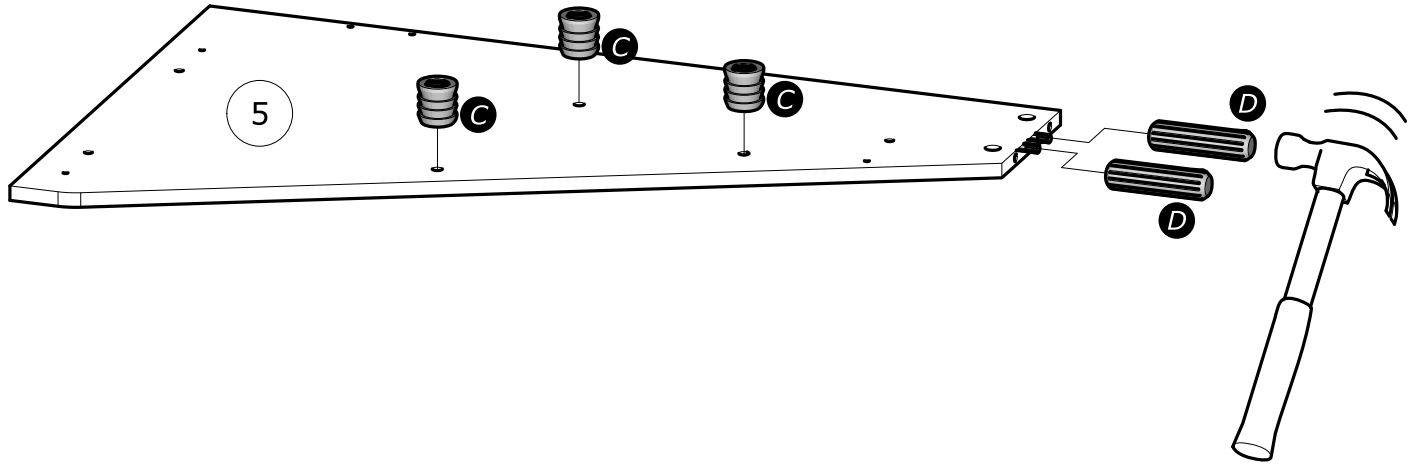
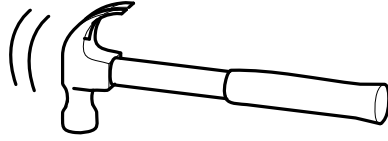
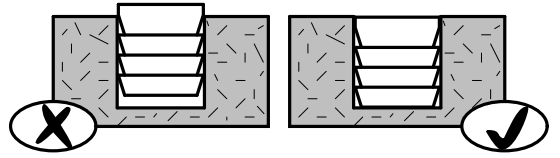

20

L x5

P x1

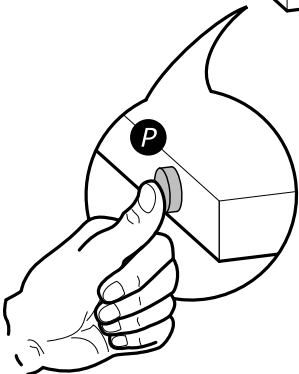
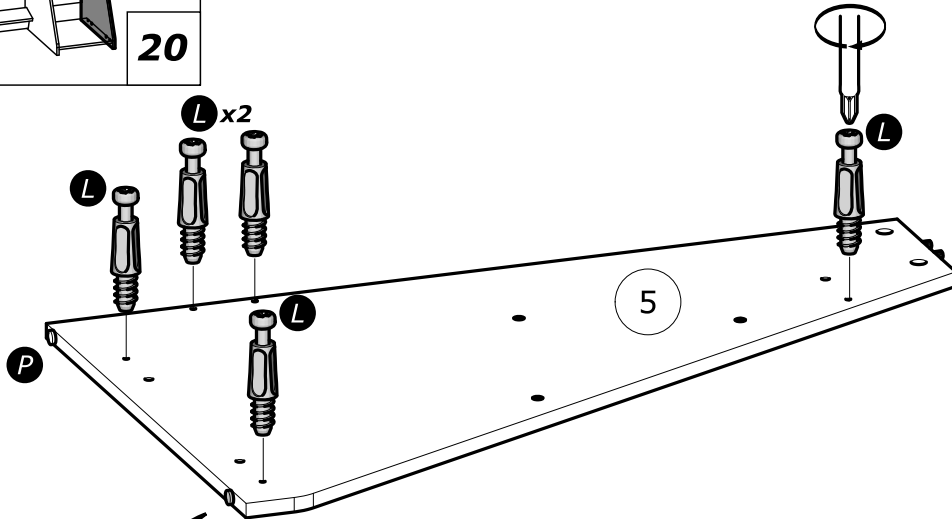

P x2

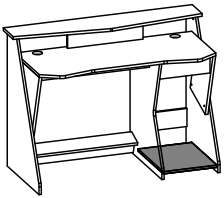

21

M x2



Ø15mm
Ø19/32"

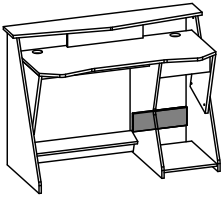
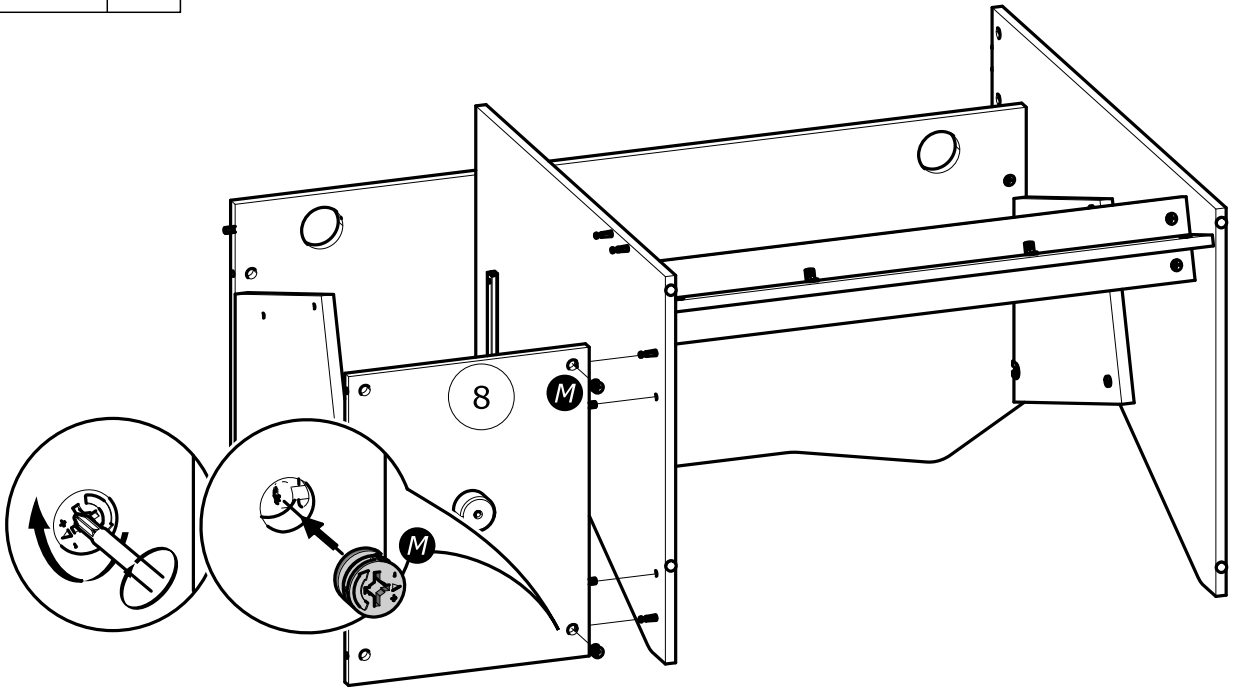

22

M x2



Ø15mm
Ø19/32"

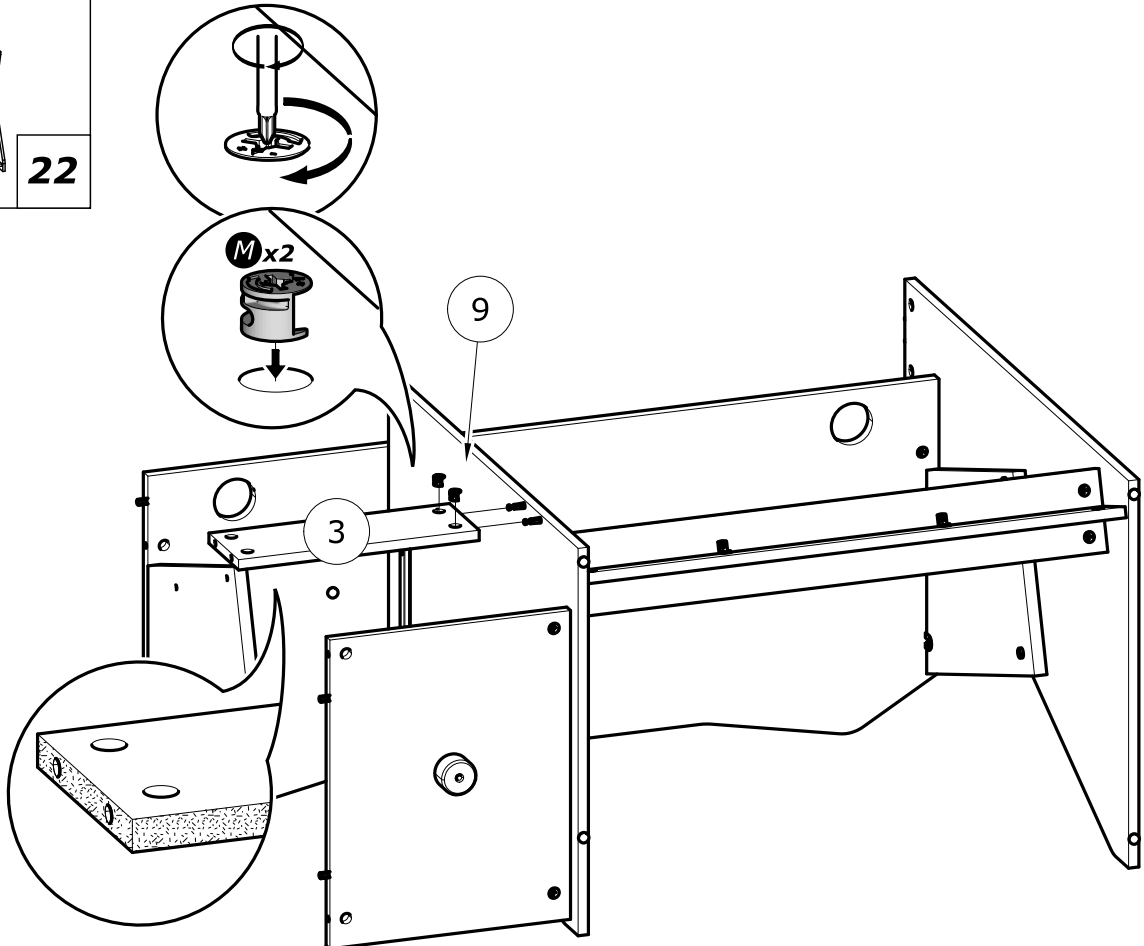

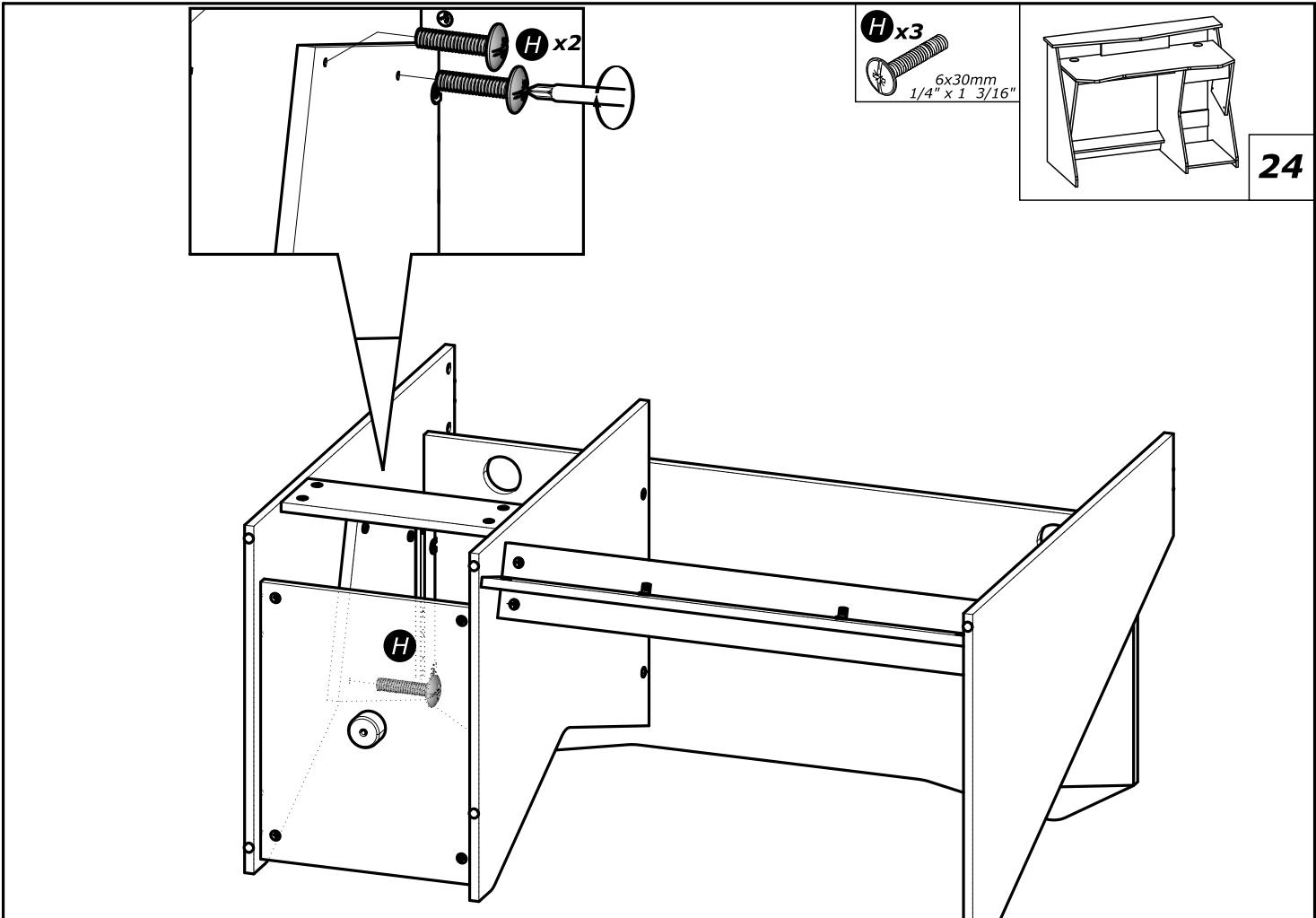
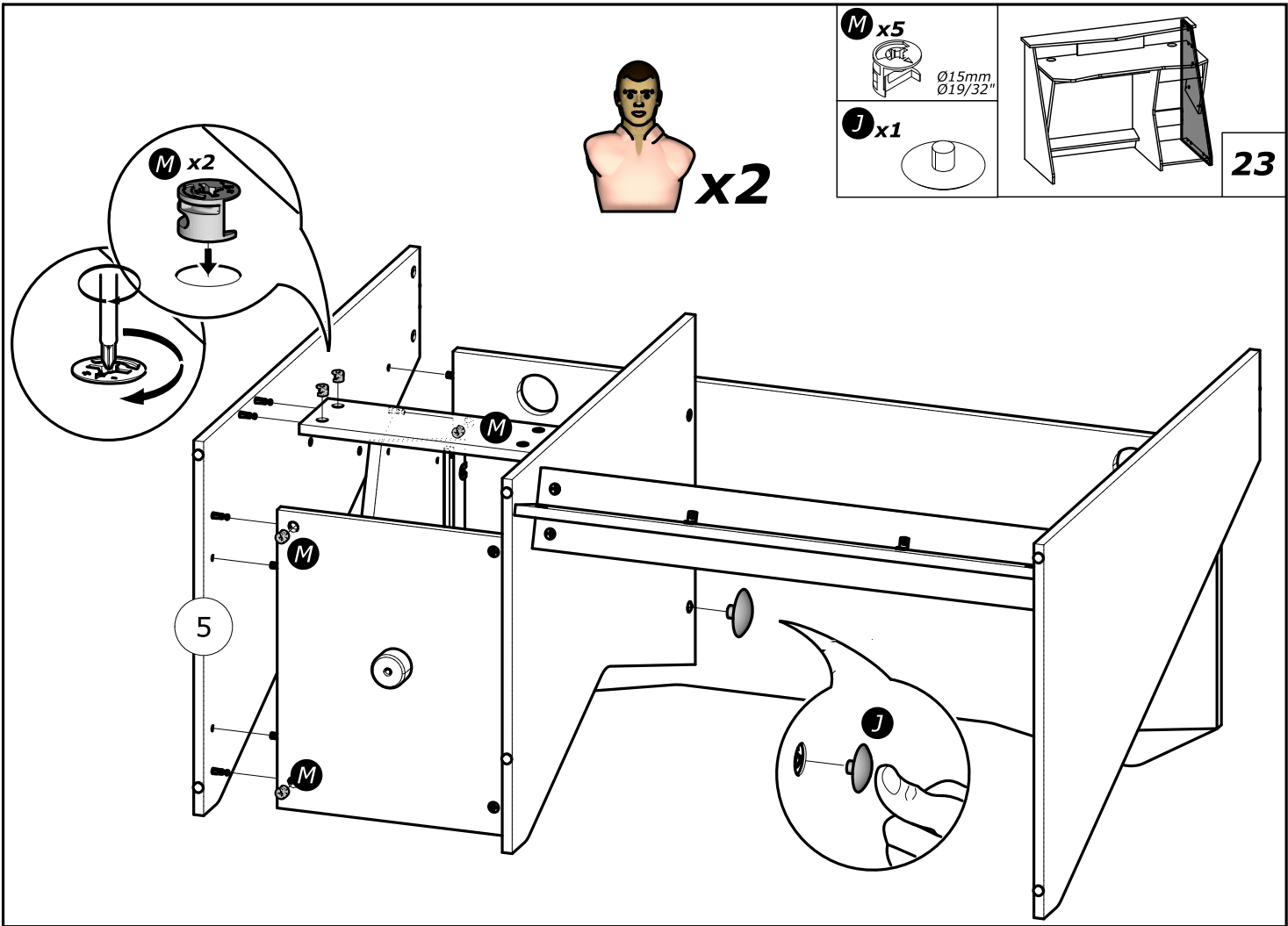

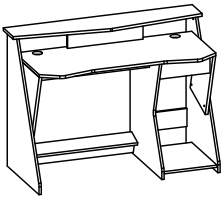

25

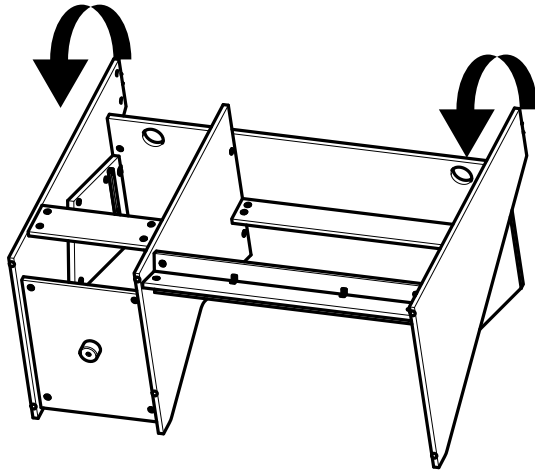

x2

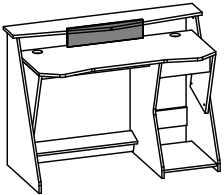
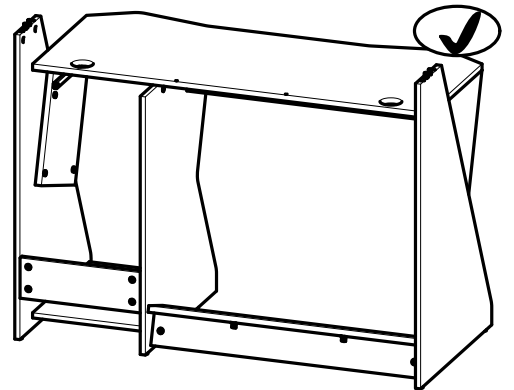

26

R x2



S x2



6.3x13mm
1/4" x 1/2"

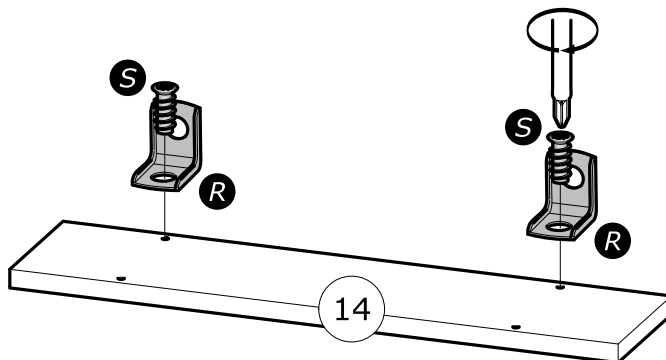

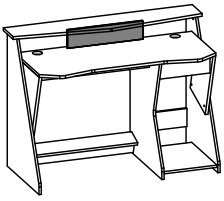

27

S x2



6.3x13mm
1/4" x 1/2"

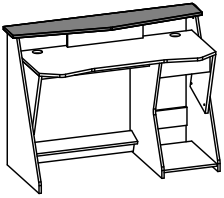
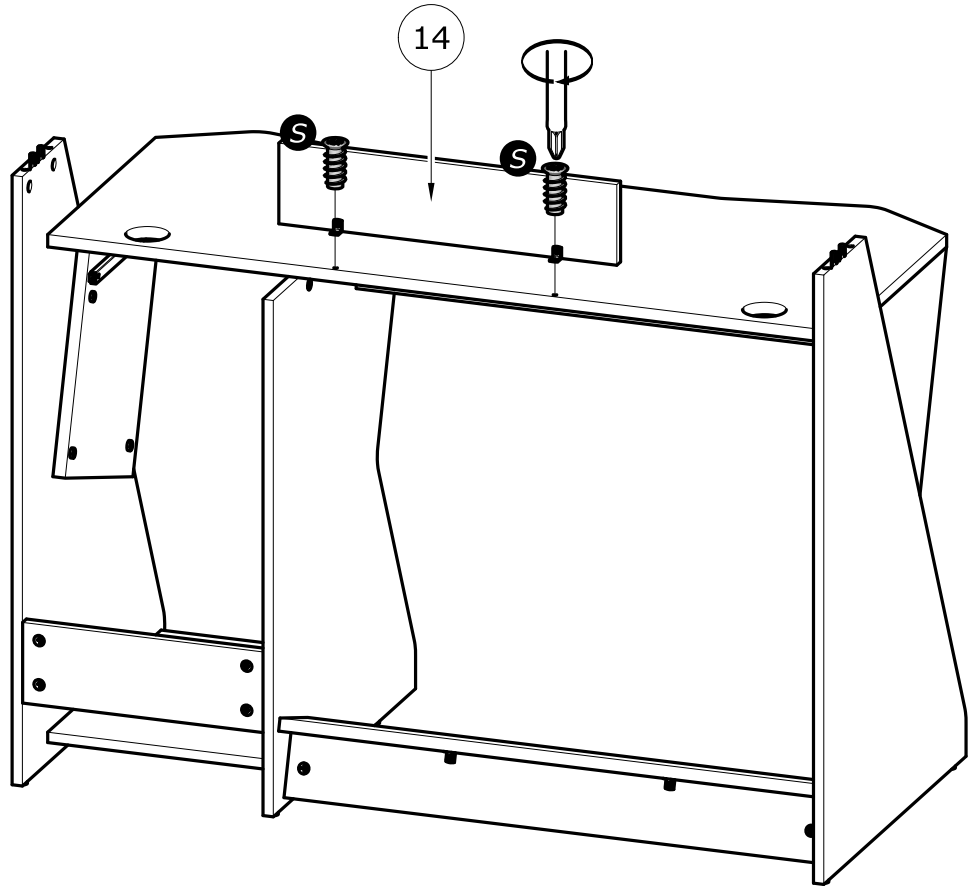

28

R x2



S x2



6.3x13mm
1/4" x 1/2"

L x4

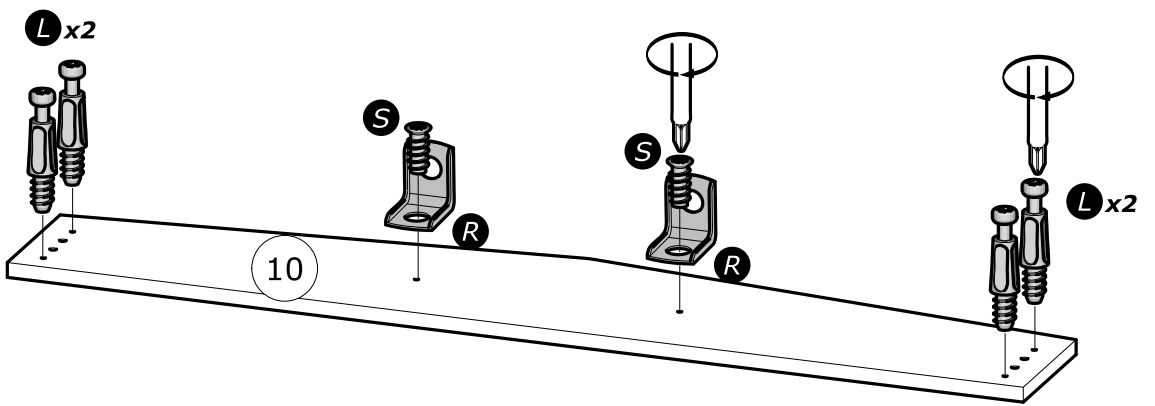
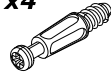

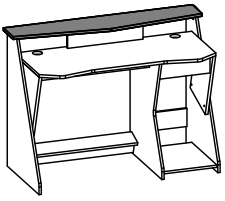

29

M x4



Ø15mm
Ø19/32"

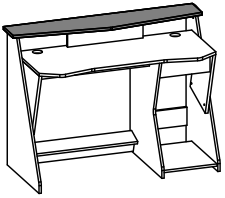
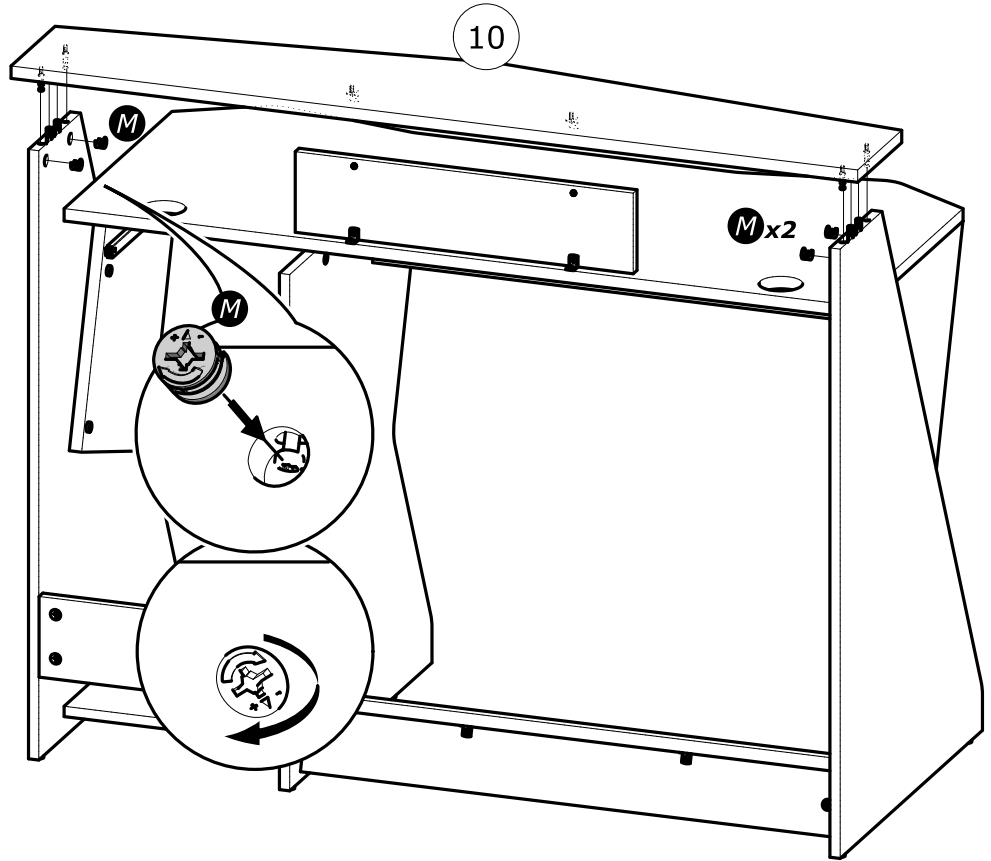

30

S x2



6.3x13mm
1/4" x 1/2"

J x4

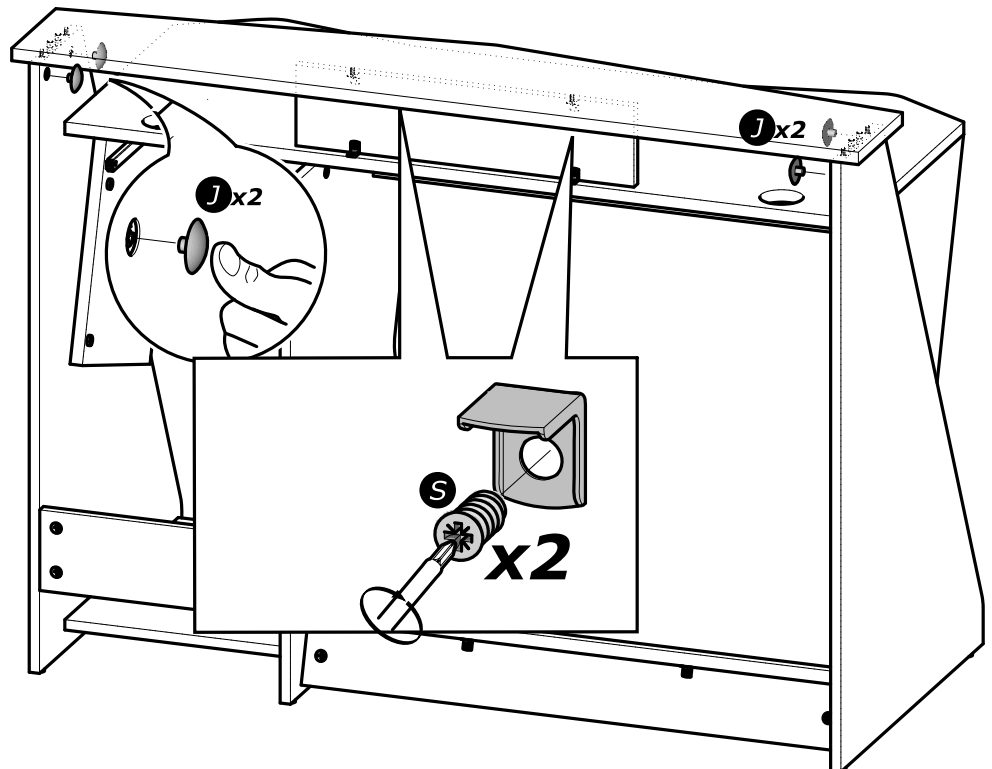
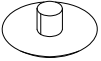

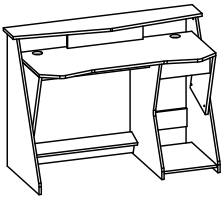

31

X x1
3.5x15mm
1/8" x 19/32"

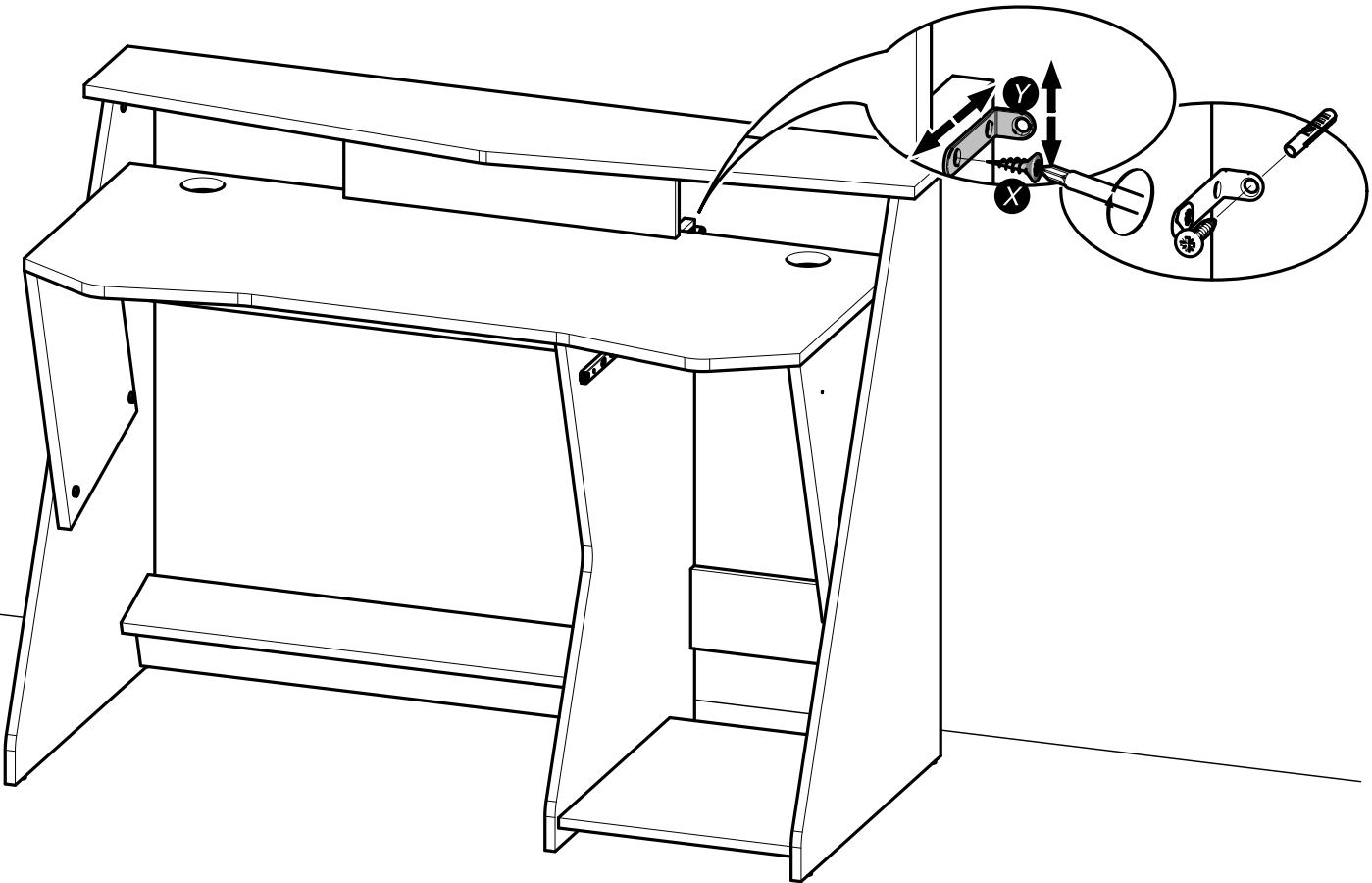
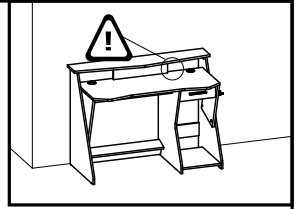
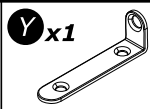

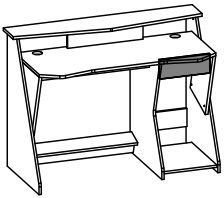

32

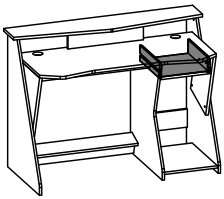
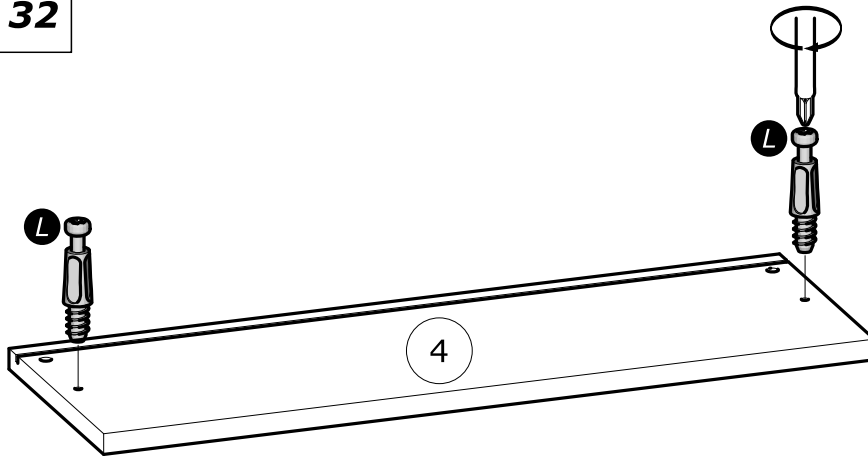
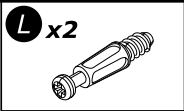

33

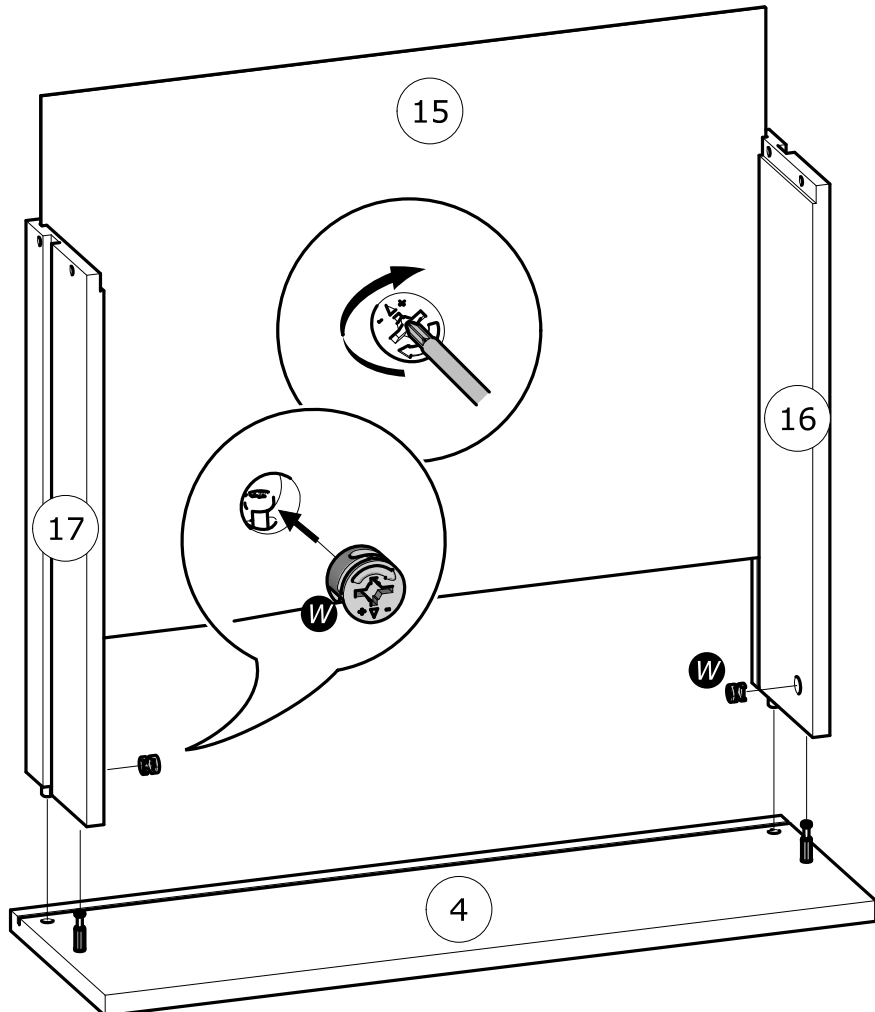
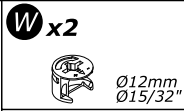

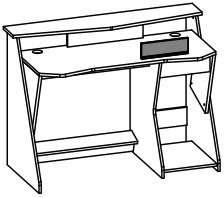

34

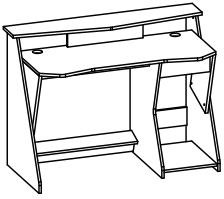
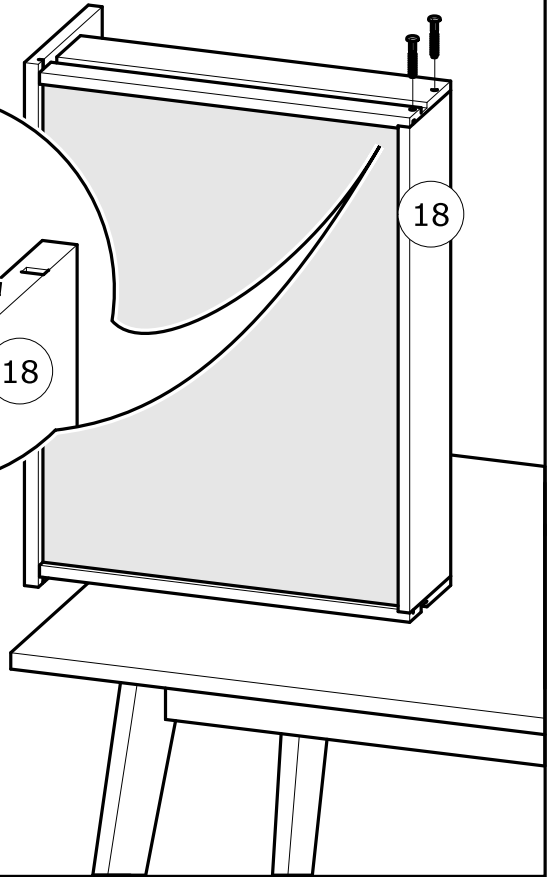
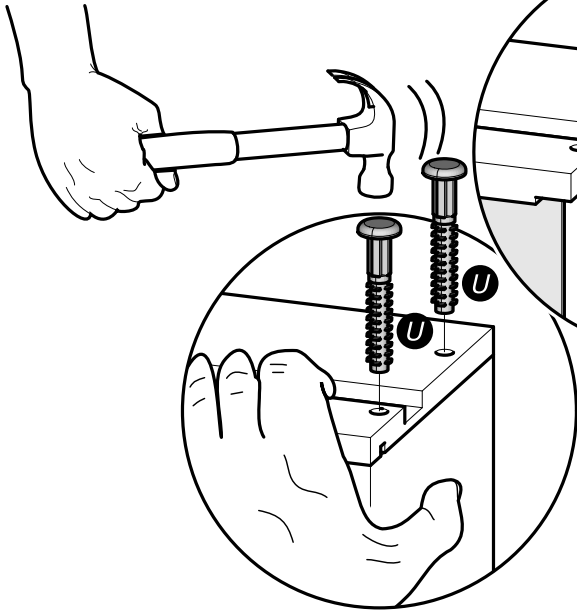
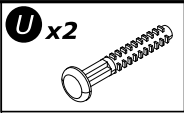

35

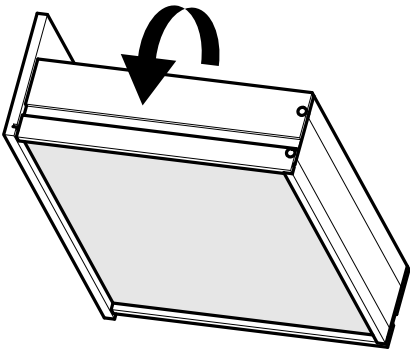
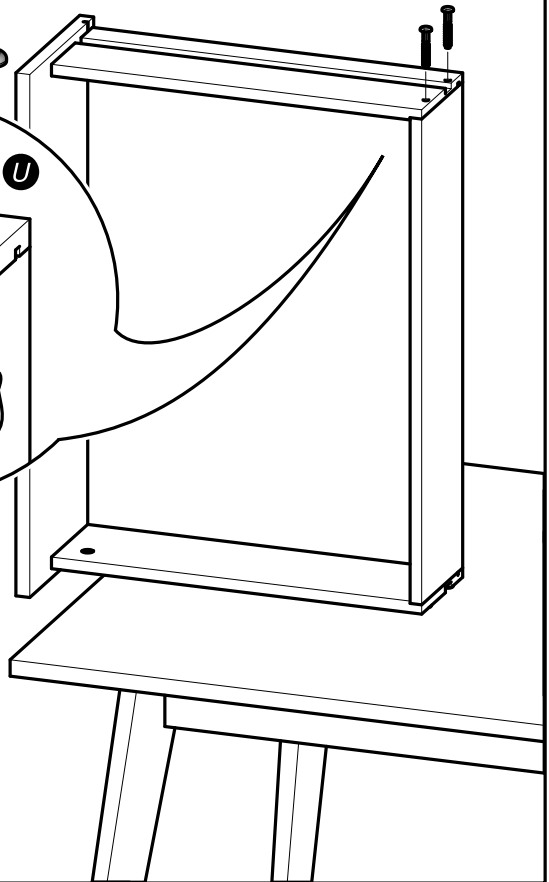
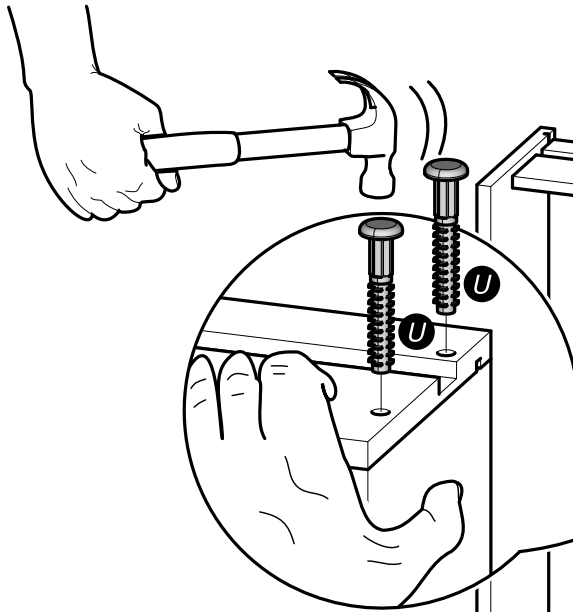
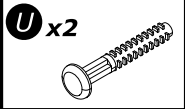

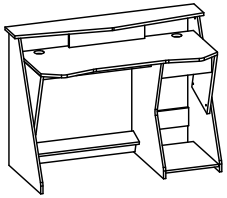

36

E x2
4x30mm
5/32" x 1 3/16"

K x1



www.Demeyere.fr

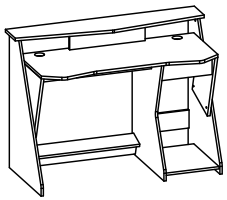
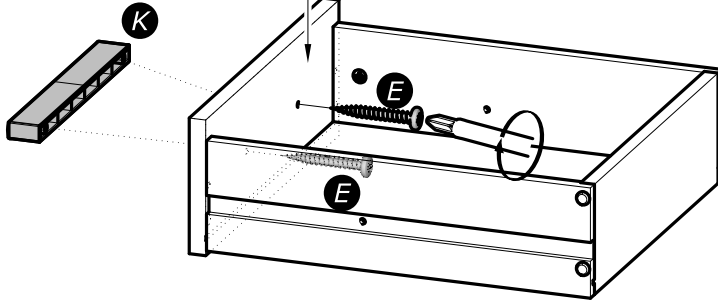
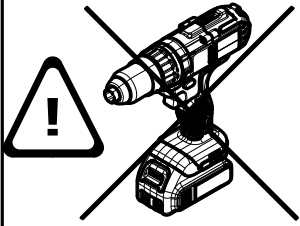

37

I x2
4x9mm
5/32" x 11/32"



www.Demeyere.fr

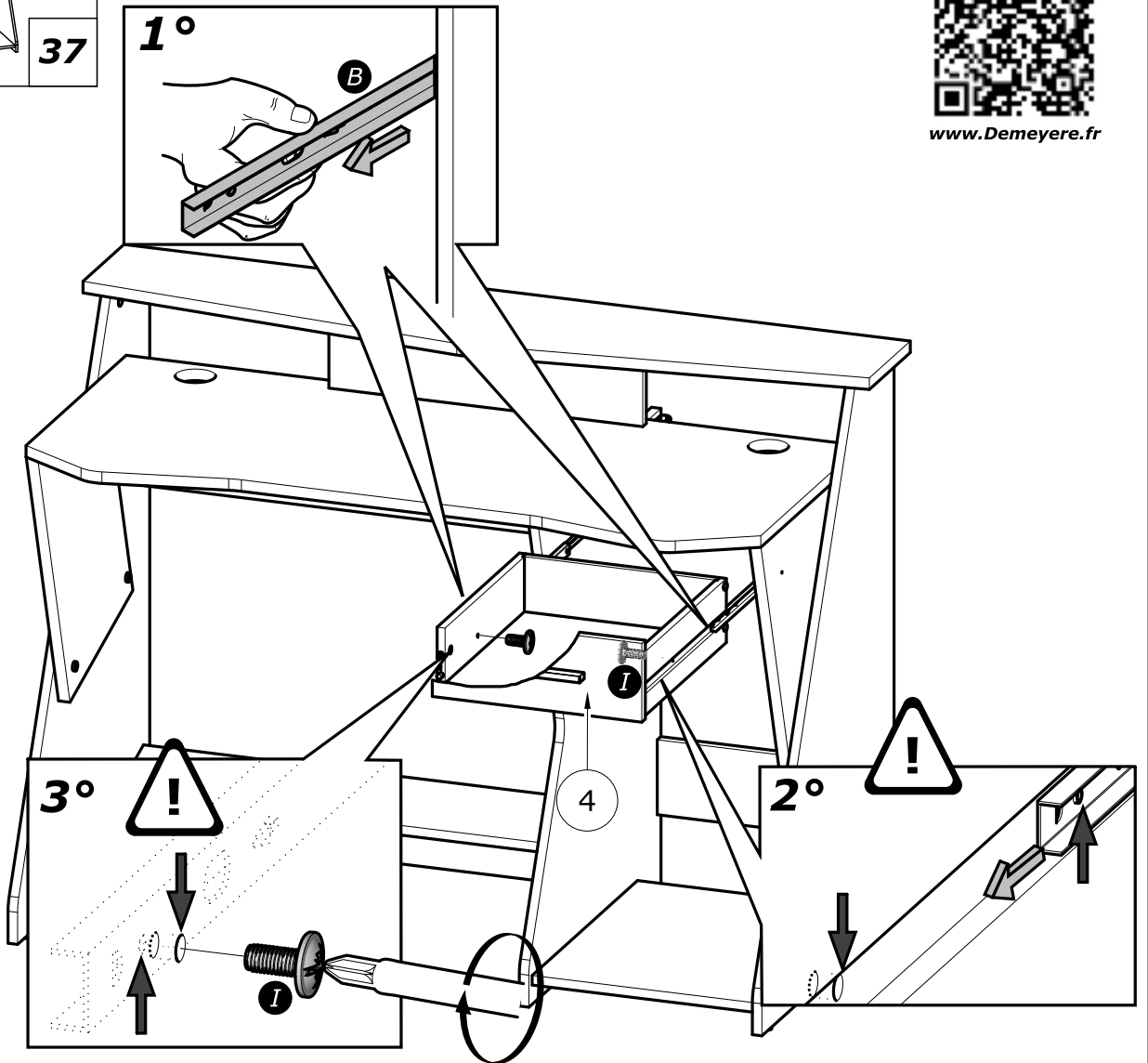

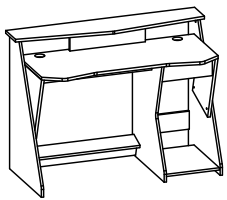

38

N x1

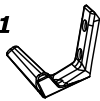

O x2

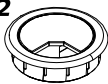

T x2

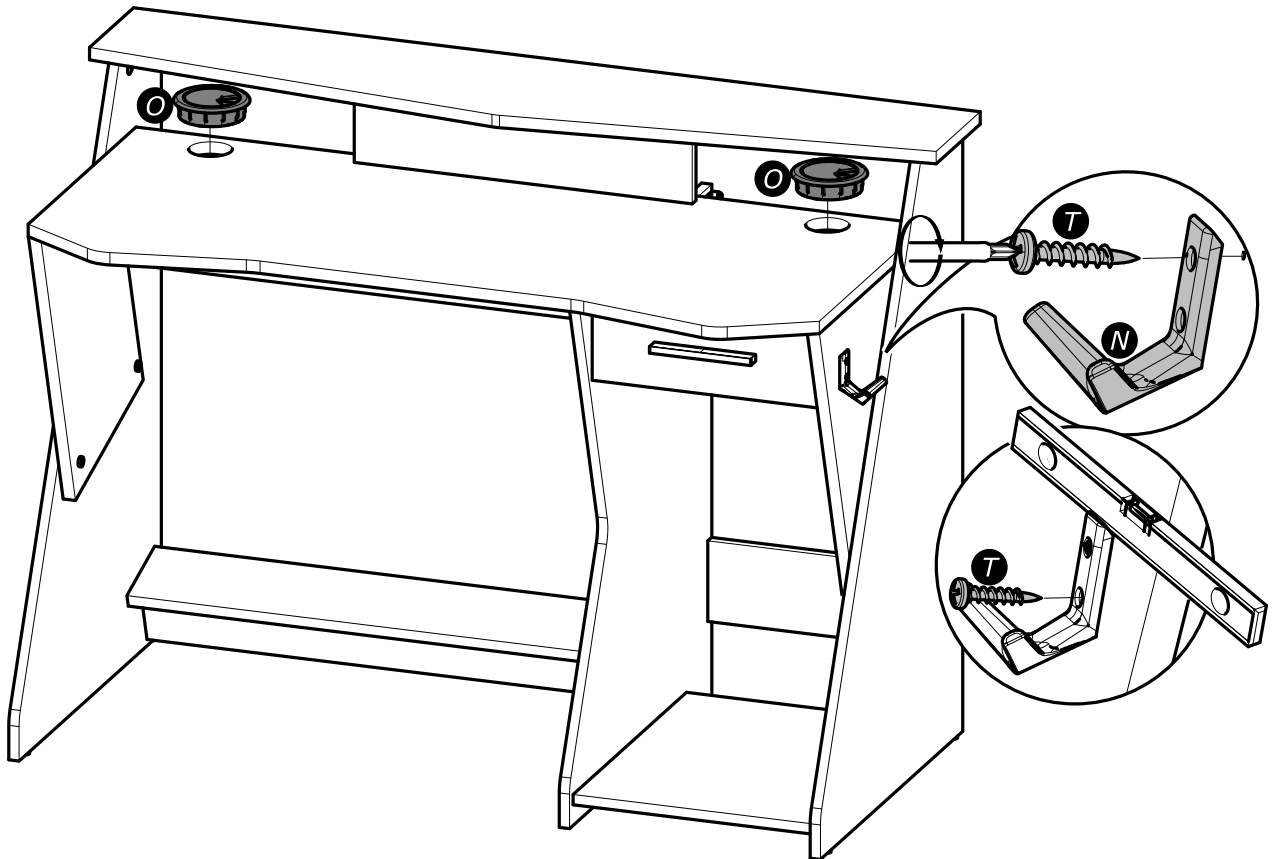
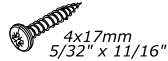

Les meubles contenant des panneaux à base de bois (panneaux de particules, panneaux de fibres, contreplaqué...) peuvent émettre des substances polluantes dans l'air intérieur. Il est ainsi recommandé, après l'installation du meuble dans son logement, d'aérer fréquemment la pièce concernée pendant au moins quatre semaines afin de réduire son exposition aux polluants émis par le meuble.



Info tri déchets

www.quefairedemesdechets.fr