

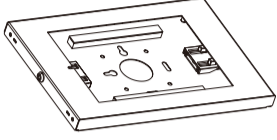









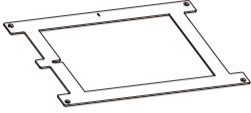
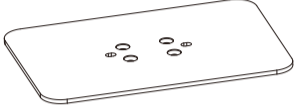
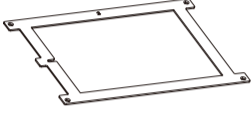

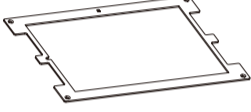

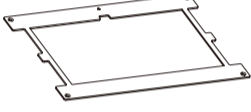

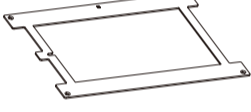

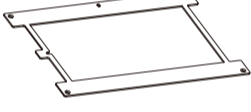



EN	Anti-Theft Tablet Floor Stand
PL	Uchwyt do tabletu podłogowy blokada
DE	Anti-Diebstahl-Tablet-Bodenständer
FR	Support de table antivol
ES	SopORTE de suelo antirrobo para tabletas
IT	Supporto da pavimento antifurto per tablet

ITEM	DESCRIPTION	QUANTITY	ITEM	DESCRIPTION	QUANTITY
A	 enclosure	1	K	 decorative cover	1
B	 panel 1	1	L	 base	1
C	 panel 2	1	M	 silicone pad	4
D	 panel 3	1	N	 M4x6	2
E	 panel 4	1	O	 M4x12	4
F	 panel 5	1	P	 M5x6	4
G	 panel 6	1	Q	 M8x20	4
H	 column	1	R	 ST6.3x55	2
I	 brochure holder	1	S	 Ø10x45	2
J	 connector	1	T	 key	1
			U	 4mm allen key	1
			V	 5mm allen key	1

1

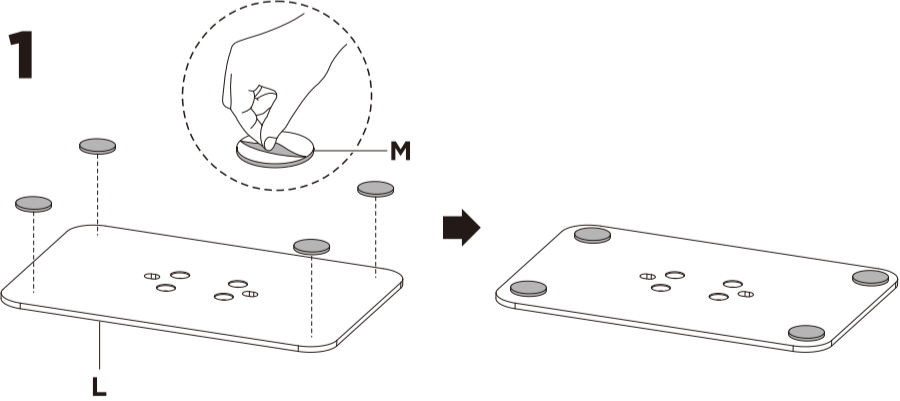

2

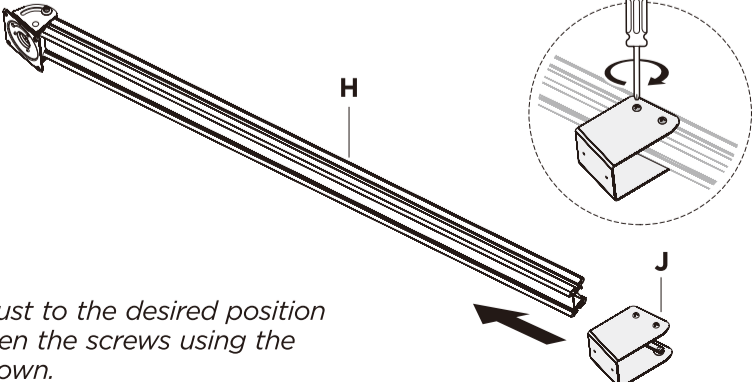

Note: Adjust to the desired position then tighten the screws using the tool as shown.

3

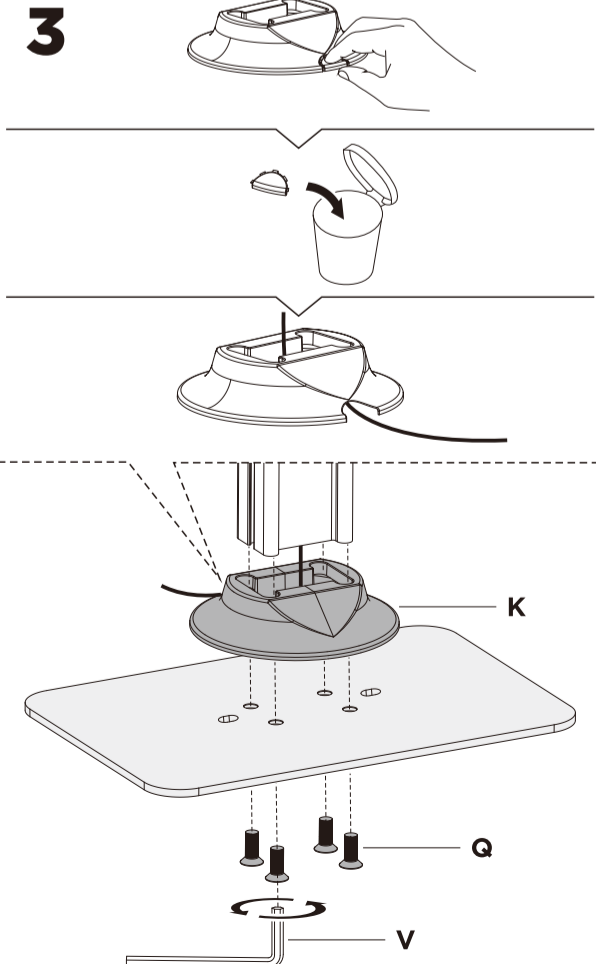

4

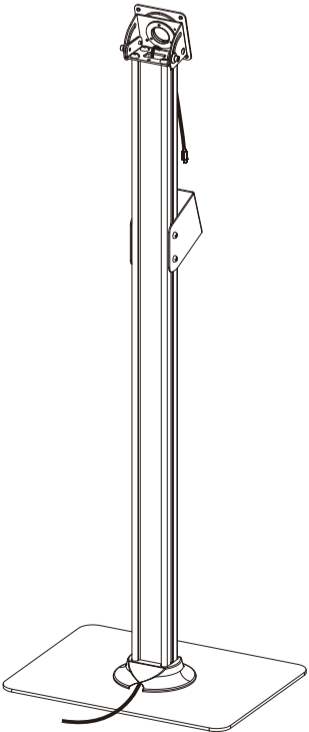

Put the mount directly on the floor.

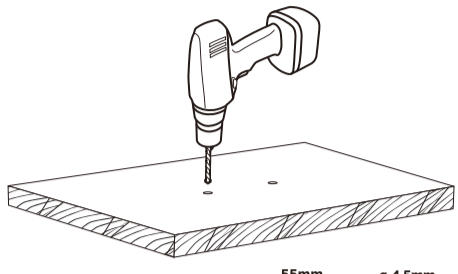
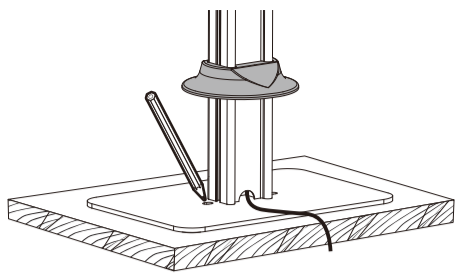

55mm (2.2")
 ø 4.5mm (ø 3/16")

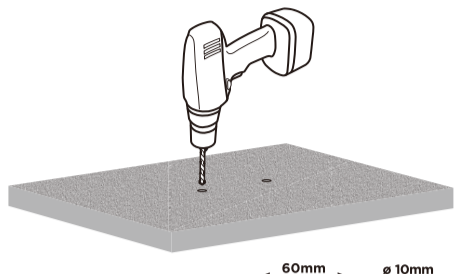
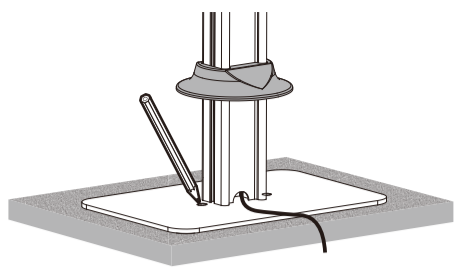

60mm (2.4")
 ø 10mm (ø 3/8")

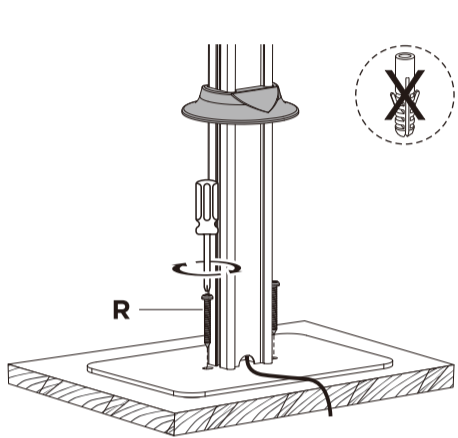

For the wooden countertop installation.

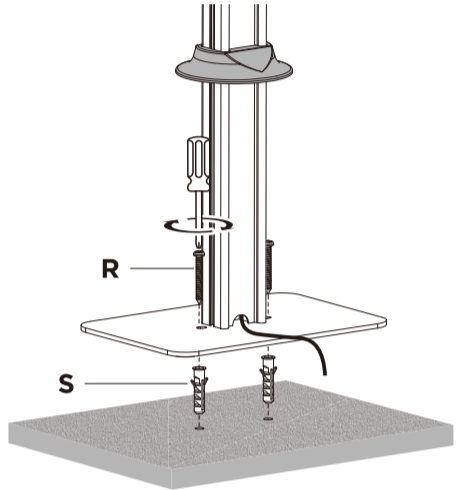

For the concrete or solid masonry installation.

5

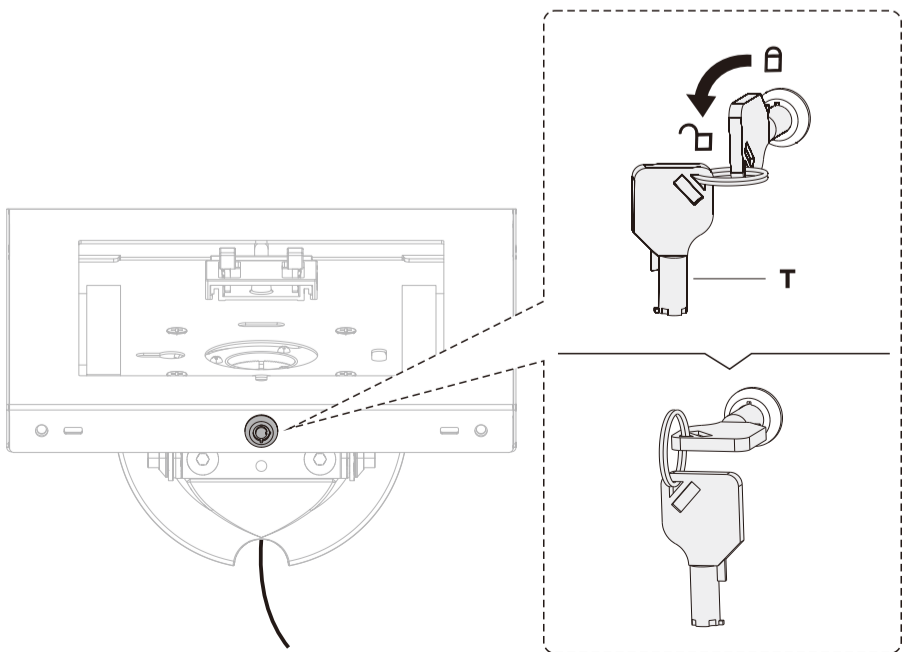
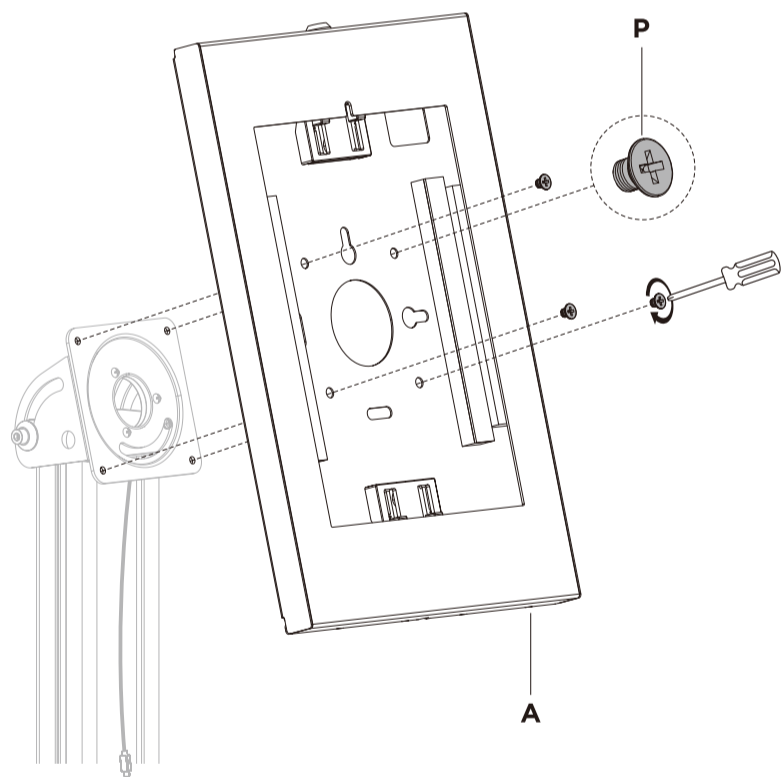

6

Note: Remove pearl cotton foam before installation.

B/C/D/E/F/G

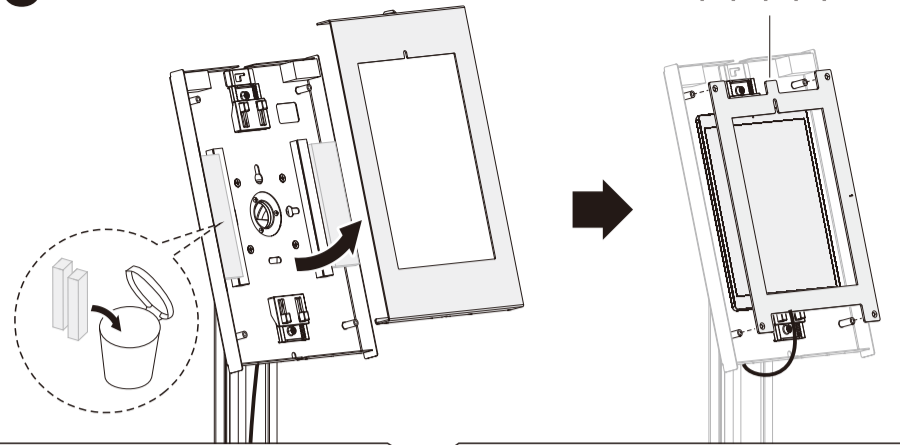

Attach the panel to the enclosure using four screws (O). Before completely tightening the screws adjust the two claws to hold the tablet and to ensure the screen is aligned and visible through the front panel.

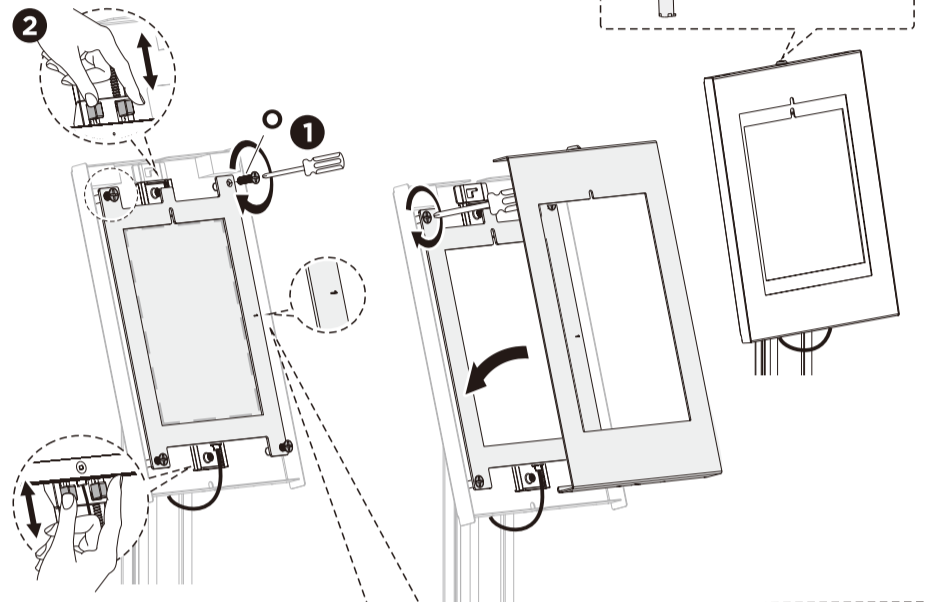
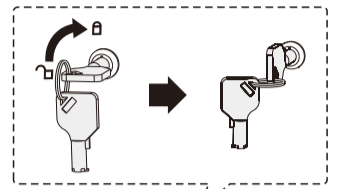

Panel 1: For 9.7" iPad 5/6, iPad Air 1/2 & iPad Pro (Gen 1)

Panel 2: For 10.2" iPad 7/8/9 & 10.5" iPad Air 3, iPad Pro (Gen 2)

Panel 3: For 11" iPad Pro (Gen 3/4/5) & 10.9" iPad Air 4

Panel 4: For 10.4" Samsung Galaxy Tab A7

Panel 5: For 10.1" Samsung Galaxy Tab A

Panel 6: For 10.4" Samsung Galaxy Tab S6 Lite

Choose the corresponding panel according to the tablet.

7

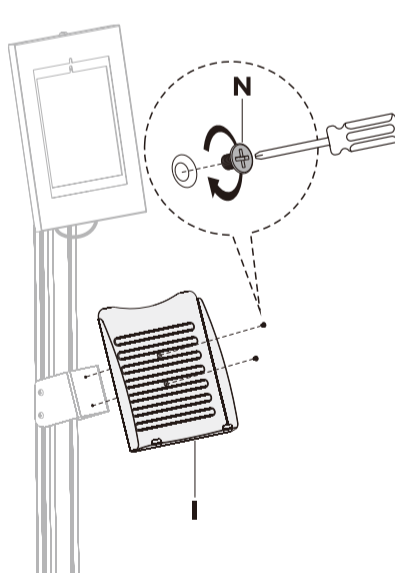

8

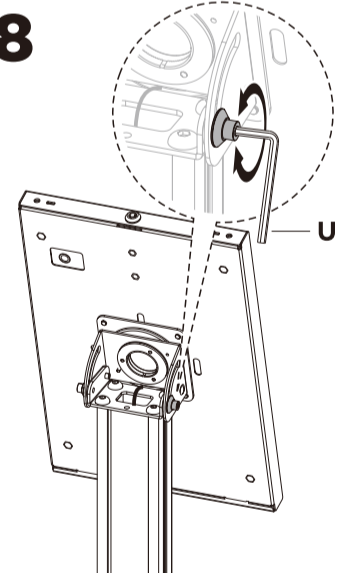

9

