

# MONTAGEANLEITUNG

Artikelnummer:WF318652  
WF318653

Diese Set ist in 2 Boxen enthalten. Wenn Sie keine vollen 2 Boxen erhalten, wenden Sie sich bitte an unseren Kundenservice.

Polsterbett 140x200cm

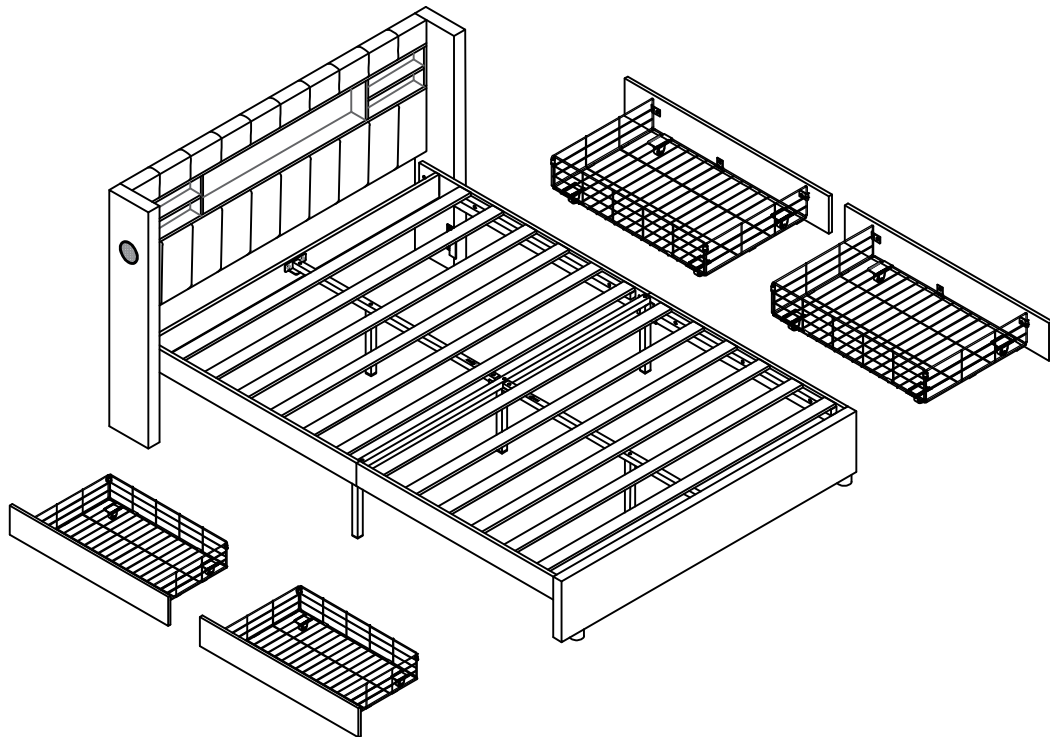

<b>D</b> Gebrauchsanweisung	<b>GB</b> Instructions for use
<b>NL</b> Gebruiksrichtlijnen	<b>FR</b> Instructions d'utilisation
<b>IT</b> Istruzioni per l'uso	<b>PL</b> Instrukcja obsługi
<b>CZ</b> Pokyny k použití	<b>ES</b> Instrucciones de empleo
<b>HU</b> Használati útmutató	<b>RO</b> Instrucțiuni de folosire
<b>PT</b> Instruções de utilização	<b>RU</b> Инструкция по монтажу
<b>SK</b> Pokyny k použitiu	<b>TR</b> Kullanım talimatları

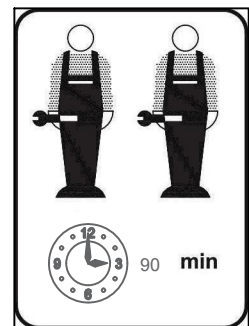

**FR - Notice de montage / EN - Assembly instructions / PT - Instruções de montagem /  
ES - Prospecto de montaje / DE - Montageanleitung / IT - Istruzioni di montaggio /  
NL - Montagehandleiding**

**FR - IMPORTANT! CONSERVER POUR CONSULTATION ULTERIEURE: LIRE ATTENTIVEMENT**

- A monter par un adulte. Un adulte doit vérifier le bon assemblage avant l'emploi
- ATTENTION! tenir les vis et petits éléments et sachets hors de portée des enfants
- Bien identifier les éléments avant de commencer le montage
- Ne pas utiliser votre article lorsque l'un de ses éléments est cassé ou manquant
- En cas de problème contactez notre service après-vente
- Toujours suivre les instructions du fabricant
- Entretien: nettoyer avec un chiffon doux et sec. En cas de taches plus grosses, frottez soigneusement avec une éponge légèrement humide et non abrasive
- Ne pas sauter sur le lit

**EN - IMPORTANT! KEEP FOR FUTURE REFERENCE: READ CAREFULLY**

- To be assembled by an adult. Assembly must be checked by an adult before use
- WARNING! keep all screws, small parts and plastic bags out of the reach of children
- Properly identify all parts before assembling
- Never use your item if any of its parts are broken or missing
- Should any problems arise, please contact our After Sales Service
- Manufacturer's instructions shall be followed at all times
- Care: clean with a soft, dry cloth. In case of larger stains, carefully rub with a slightly damp, non-abrasive sponge
- Do not jump on the bed

**PT - IMPORTANTE! GARDE PARA CONSULTA POSTERIOR: LER ESTAS INSTRUÇÕES CUIDADOSAMENTE**

- A ser montado por um adulto. Um adulto deve verificar a boa montagem antes da utilização
- Atenção! mantenha os parafusos, acessórios pequenos e saco de plástico fora do alcance das crianças
- Identifique bem os acessórios antes de começar a montagem
- Não utilizar o artigo se um dos elementos está em falta ou danificado
- Para qualquer esclarecimento, contacte os nossos serviços através do telefone
- As instruções do fabricante devem ser sempre cumpridas
- Manutenção: limpe com um pano macio e seco. Em caso de manchas maiores, esfregue cuidadosamente com uma esponja ligeiramente húmida e não abrasiva
- Não salte na cama

**ES - IMPORTANTE! CONSERVAR PARA FUTURAS CONSULTAS: LEER DETENIDAMENTE**

- A montar por un adulto. Un adulto debe comprobar el buen montaje antes de la utilización
- ¡ADVERTENCIA! mantener los tornillos, los pequeños elementos y bolsitas fuera del alcance de los niños
- Identificar debidamente los elementos antes de empezar el montaje
- No utilizar este artículo si uno de los elementos falta o esta roto
- Si tiene problemas, contactar nuestro servicio postventa
- Deben seguirse siempre las instrucciones del fabricante Cuidados: limpiar con un paño suave y seco. En caso de manchas grandes, frotar con cuidado utilizando una esponja húmeda no abrasiva
- No saltar sobre la cama

**DE - WICHTIG! FÜR SPÄTERE BEZUGNAHME AUFBEWAHREN: SORGFÄLTIG LESEN**

- Von einem Erwachsenen zu montieren. Die korrekte Montage muss vor Gebrauch von einem Erwachsenen geprüft werden
- Achtung! die Schrauben und kleinen Teile ausserhalb der Reichweite von Kindern lagern
- Vor Montagebeginn alle Teile identifizieren
- Ihren Artikel nicht benutzen, wenn eines seiner Bestandteile beschädigt ist oder fehlt
- Im Problemfall Ihren Kundendienst anrufen
- Stets die Herstelleranweisungen beachten
- Wartung: Mit einem weichen, trockenen Tuch reinigen. Bei größeren Flecken vorsichtig mit einem leicht feuchten, nicht scheuernden Schwamm abreiben
- Nicht auf dem Bett springen

**IT - IMPORTANTE! CONSERVARE QUESTE INFORMAZIONI PER ULTERIORI CONSULTAZIONI: LEGGI ATTENTAMENTE**

- Il montaggio deve essere eseguito da un adulto. Un adulto dovrà verificare il corretto montaggio prima dell'uso
- ATTENZIONE! tenere le viti ed i componenti di piccole dimensioni lontano dalla portata dei bambini
- Controllare i pezzi prima del montaggio
- L'articolo non deve essere utilizzato in caso di elementi mancanti o danneggiati
- In caso di necessità contattare il nostro servizio post-vendita
- Seguire sempre le istruzioni del costruttore
- Manutenzione: pulire con un panno morbido e asciutto. Per le macchine più grandi, strofinare accuratamente con una spugna leggermente umida e non abrasiva
- Non saltare sul letto



**NL - BELANGRIJK! BEWAAR VOOR LATERE RAADPLEGING: LEES AANDACHTIG**

- Moet door een volwassene worden gemonteerd. Voor gebruik moet een volwassene controleren dat het product goed in elkaar is gezet
- WAARSCHUWING! schroeven en kleine elementen en zakjes buiten bereik van kinderen houden
- De elementen goed identificeren alvorens met de montage te beginnen
- Uw artikel niet gebruiken wanneer een van de onderdelen kapot is of ontbreekt
- Neem bij problemen contact op met onze klantenservice
- Volg altijd de instructies van de fabrikant
- Onderhoud: maak schoon met een zachte en droge doek. In geval van grotere vlekken, veeg voorzichtig schoon met een licht bevochtigde en niet-schurende spons
- Niet springen op het bed

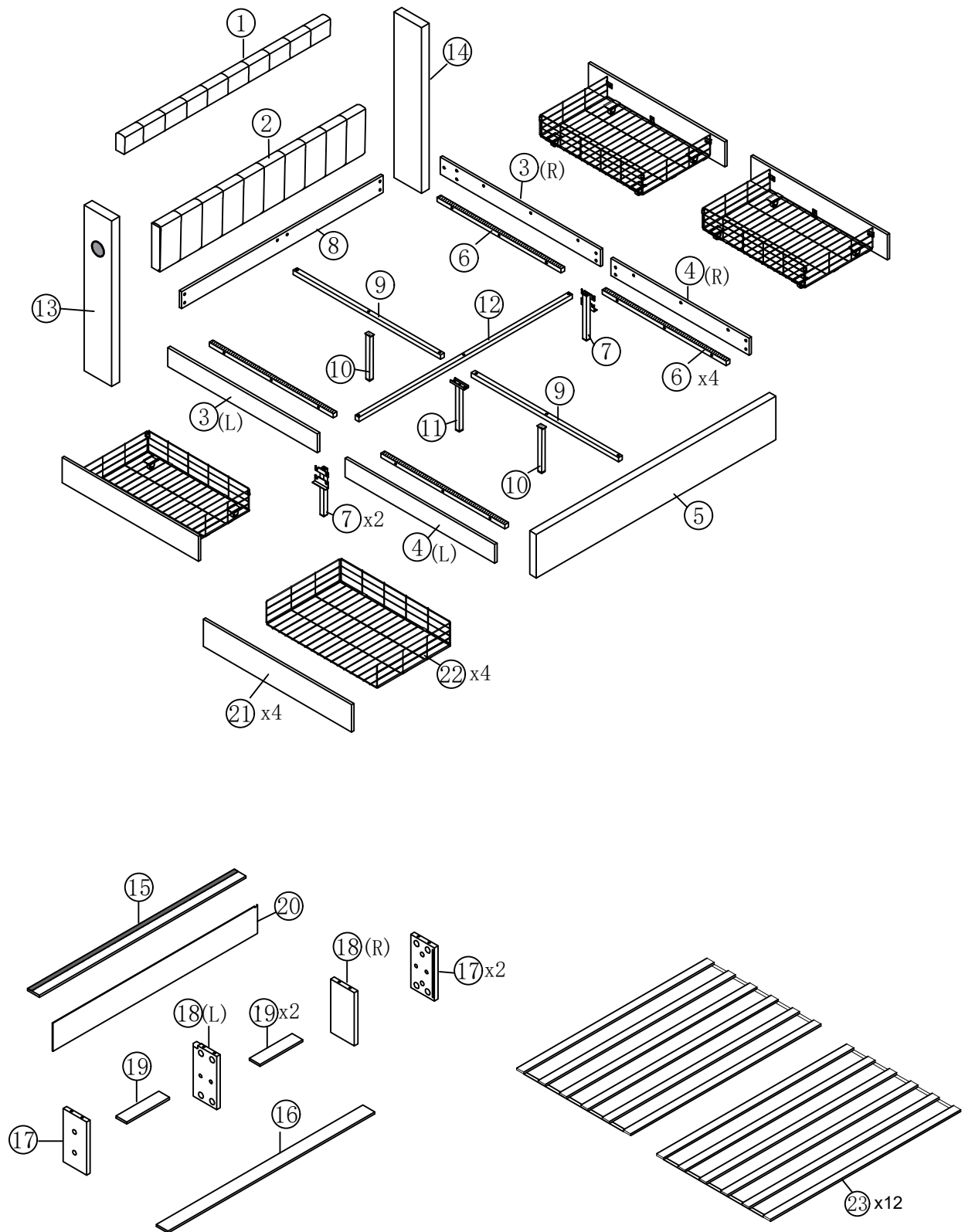

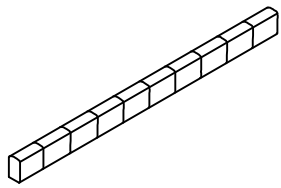
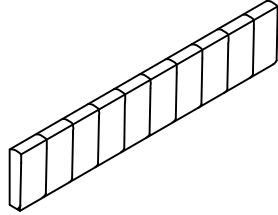
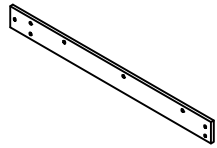
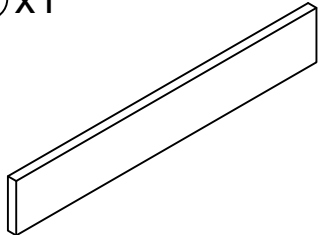
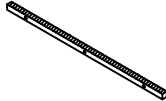
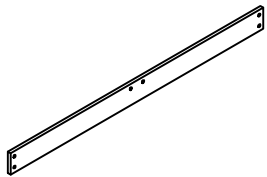
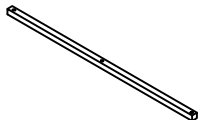
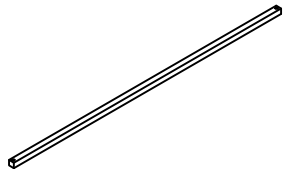
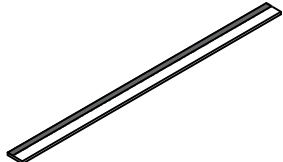
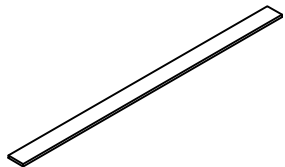

# Stückliste

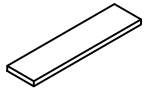
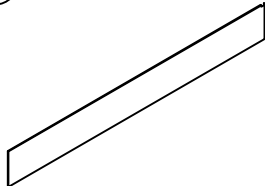
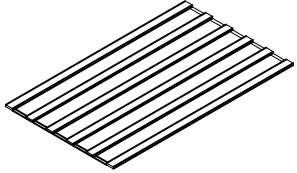



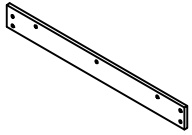
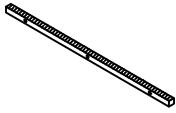

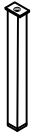
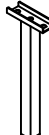

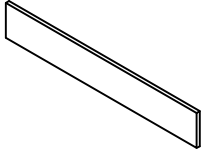
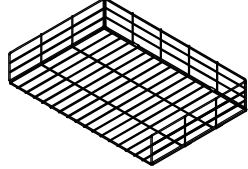

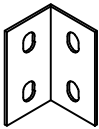

# WF318653

① x1 	② x1 	③ x2 
⑤ x1 	⑥ x2 	⑧ x1 
⑨ x2 	⑫ x1 	⑮ x1 
⑯ x1 	⑰ x2 	⑱ x2 
⑲ x2 	⑳ x1 	㉓ x12 

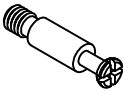

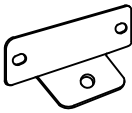
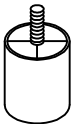
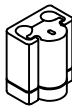
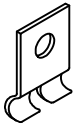
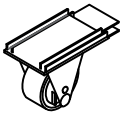
# WF318652

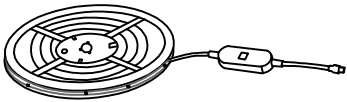
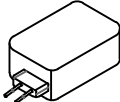
<p>④ x2</p> 	<p>⑥ x2</p> 	<p>⑦ x2</p> 
<p>⑩ x2</p> 	<p>⑪ x1</p> 	<p>⑬ x1</p> 
<p>⑭ x1</p> 	<p>⑳ x4</p> 	<p>㉒ x4</p> 

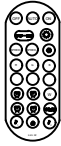
# Hardware-Liste + WF318652



<p>A x1</p> 	<p>B x35</p>  <p>M8x40mm</p>	<p>C x52</p>  <p>M8x16mm</p>
<p>D x8</p> 	<p>E x2</p> 	<p>F x16</p> 
<p>G x16</p> 	<p>H x2</p> 	<p>I x2</p> 
<p>J x8</p> 	<p>K x12</p> 	<p>L x16</p> 
<p>M x8</p> 	<p>N x1</p> 	<p>O x1</p> 
<p>P x1</p> 	<p>Q x1</p> 	<p>R x1</p> 

# Schritt 1

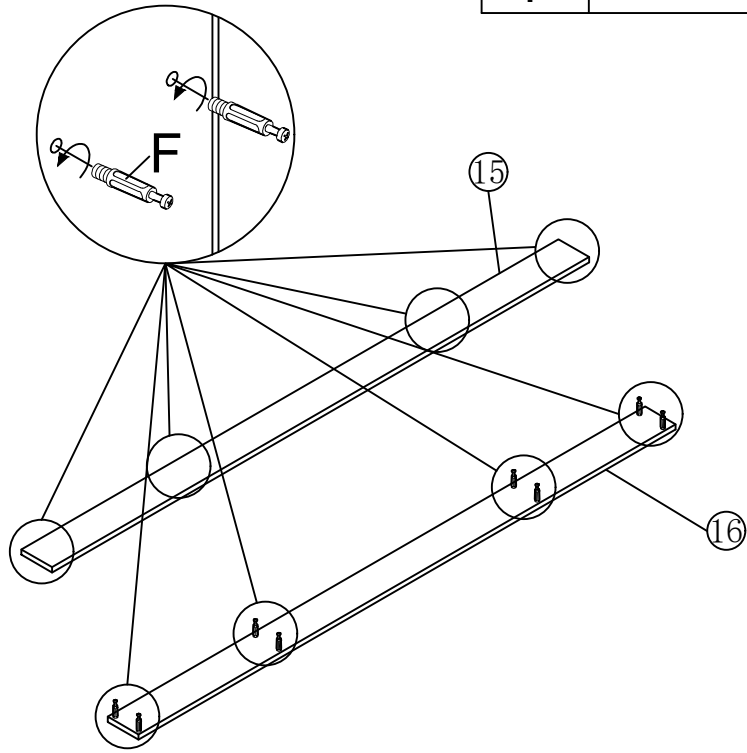
A		1
F		16



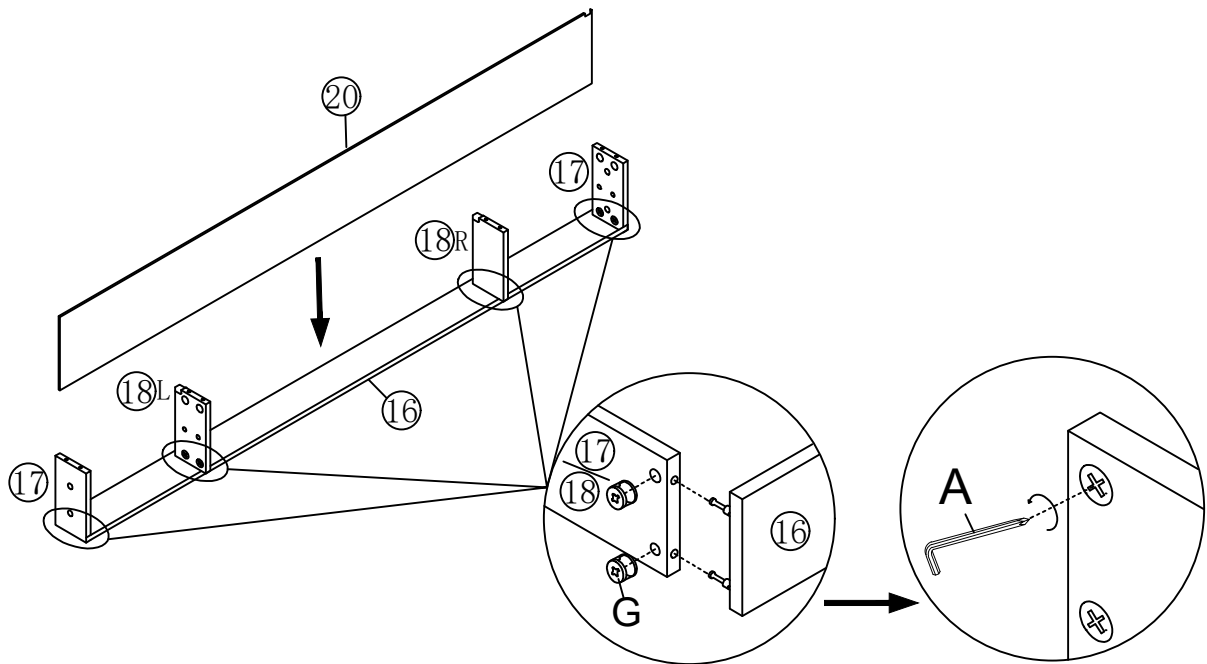

# Schritt 2

A		1
G		8



### Schritt 3

A		1
G		8

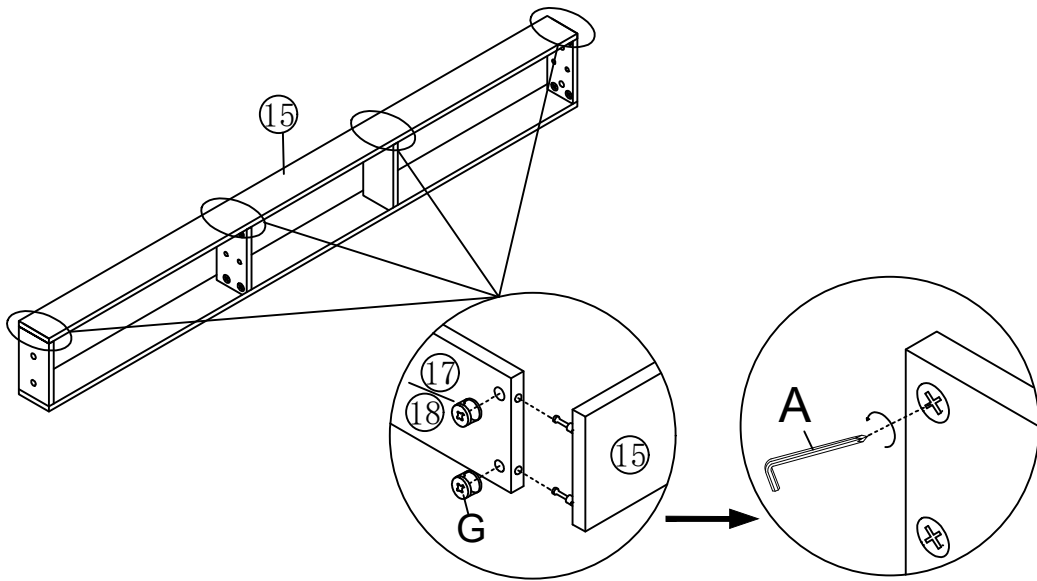

### Schritt 4

M		8
---	---	---

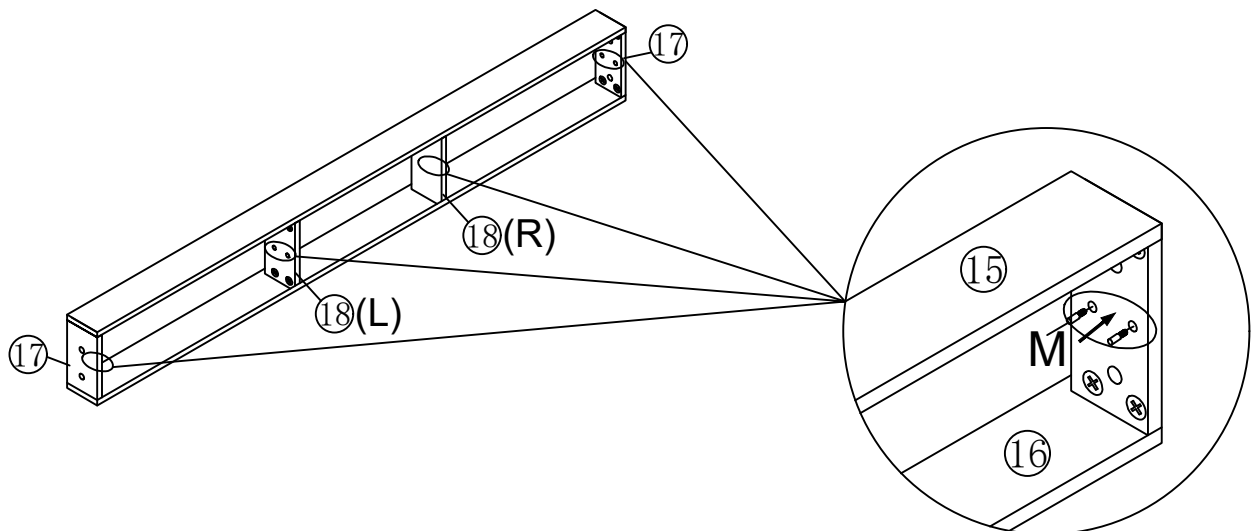





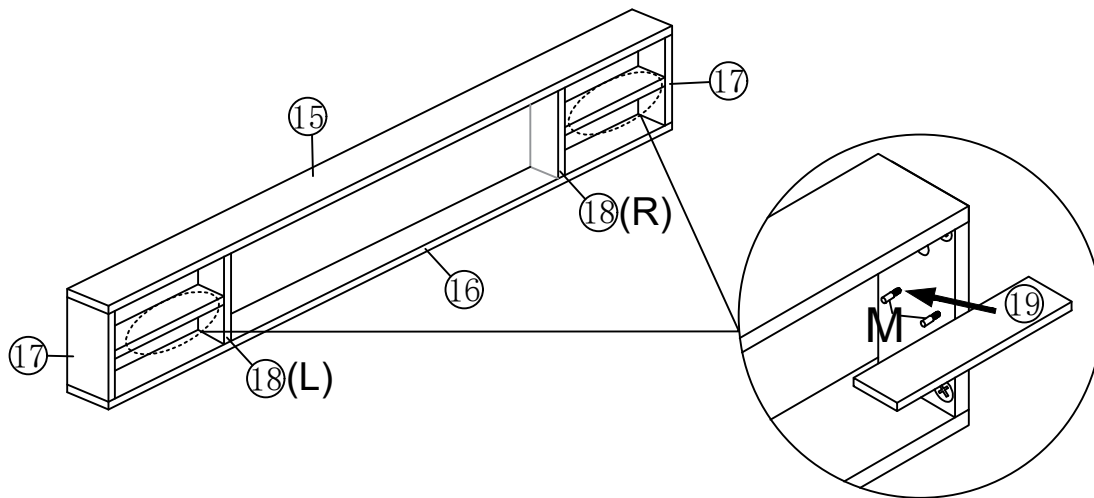

## Schritt 5

Place the notched part of board 19 facing downwards on the laminated nail M.

Legen Sie den gekerbten Teil des Brettes 19 nach unten auf den laminierten Nagel M.



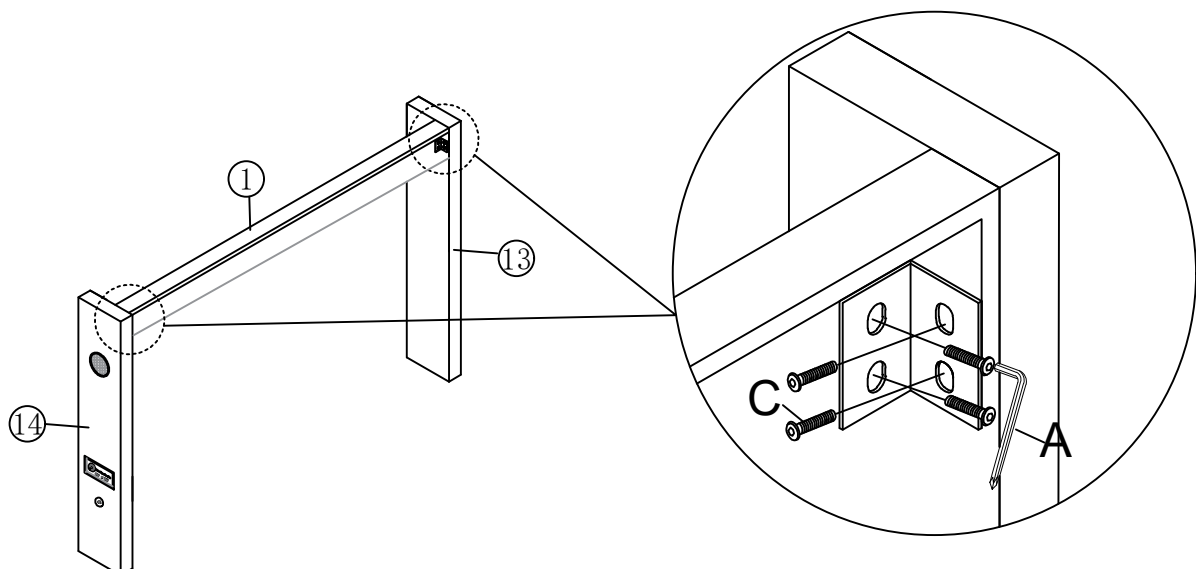

## Schritt 6

A		1
C	  M8X16mm	8
D		2



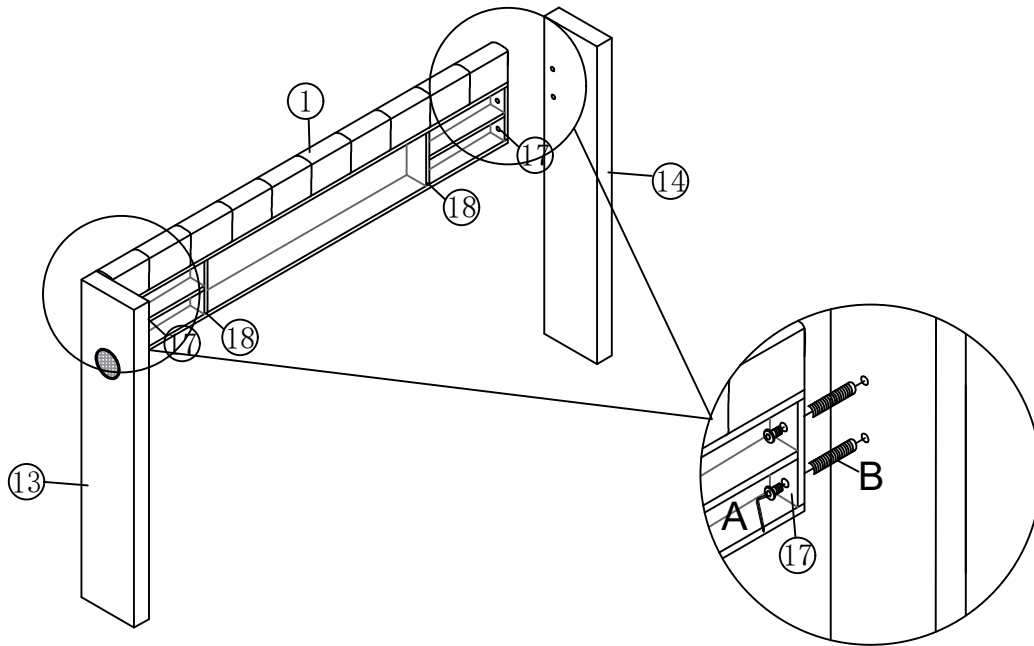

# Schritt 7

A		1
B	 M8X40mm	4



# Schritt 8

A		1
B	 M8X40mm	4

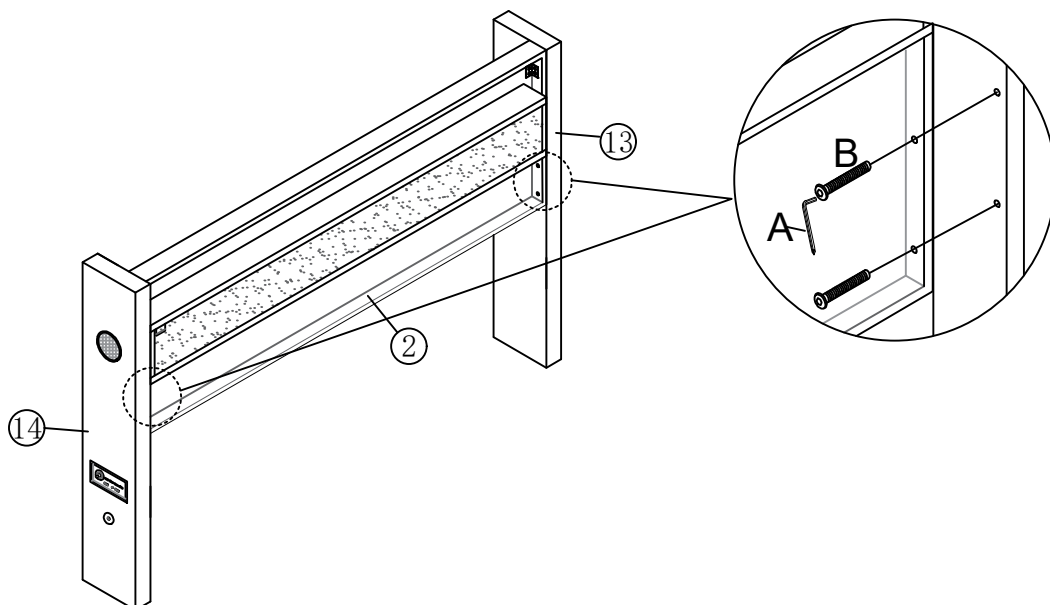

## Schritt 9

P



1

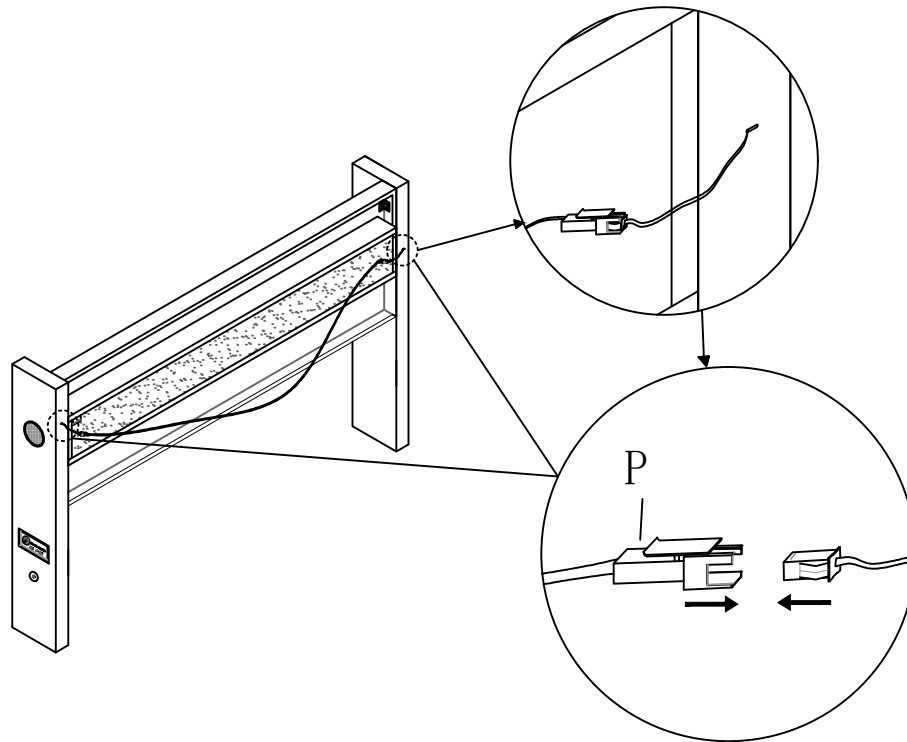

## Schritt 10

N





1

Remove the light strip, thread the tail forward from behind the light box, and then stick it from left to right. Insert the plug into the USB socket of the audio controller.

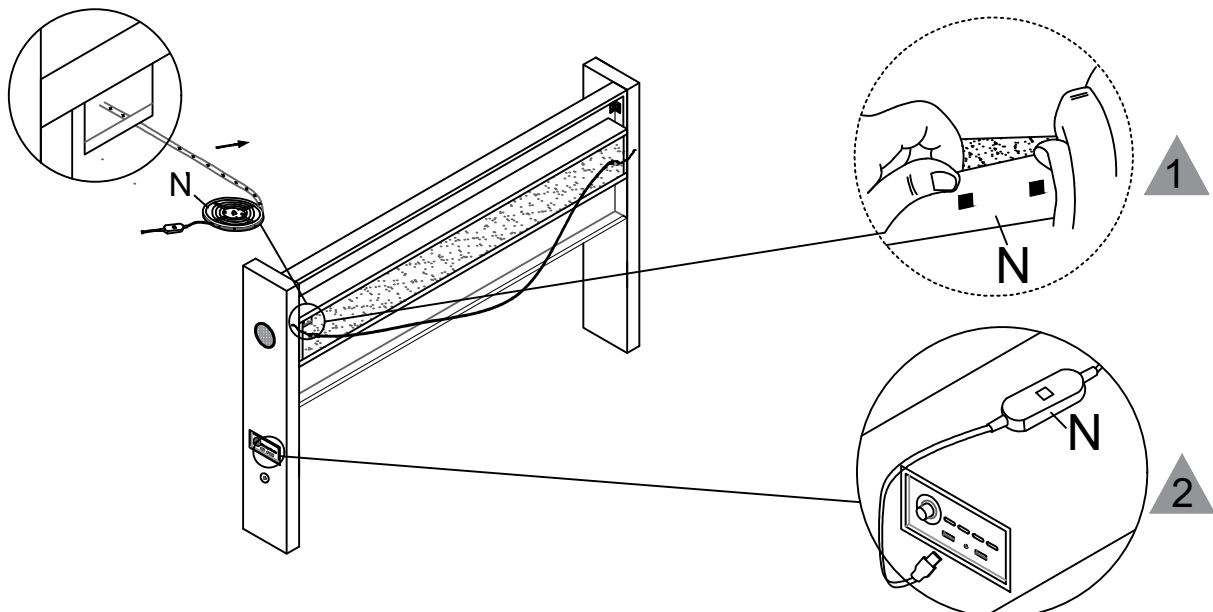
Entfernen Sie den Lichtstreifen, fädeln Sie den Schwanz hinter dem Leuchtkasten nach vorne und kleben Sie ihn dann von links nach rechts. Stecken Sie den Stecker in die USB-Buchse des Audio-Controllers.



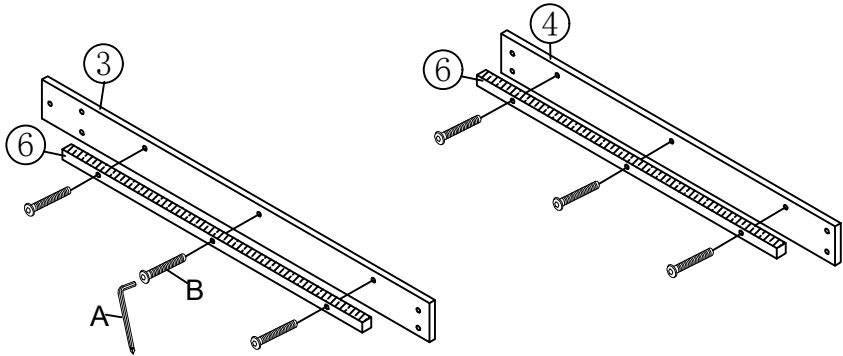

# Schritt 11 X2

A		1
B	 M8X40mm	12



# Schritt 12 X2

A		1
C	 M8X16mm	8

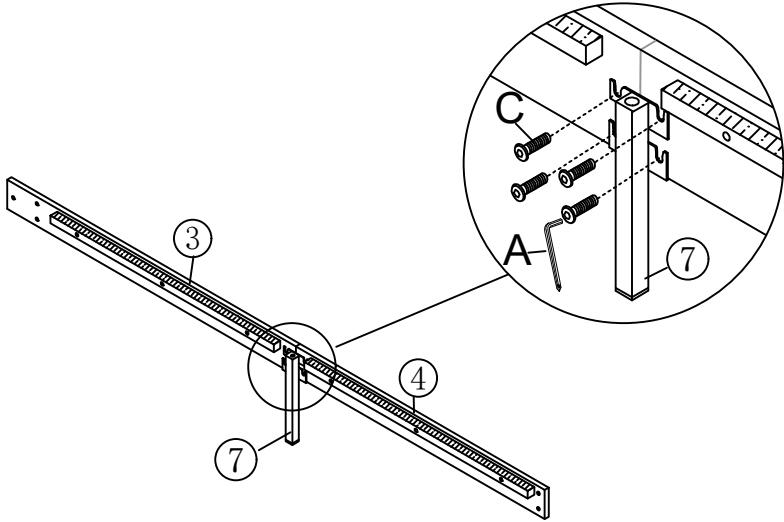



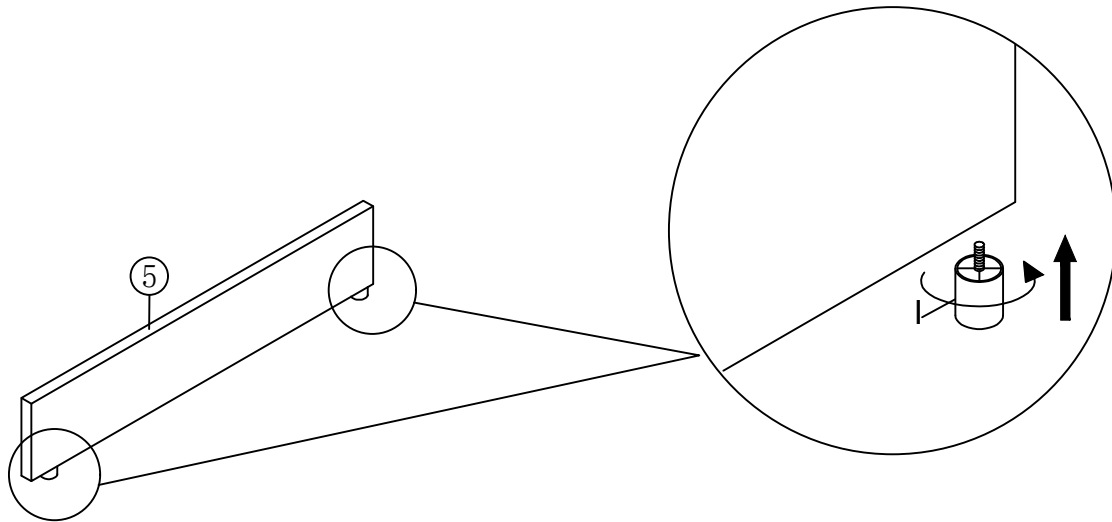

# Schritt 13

I		2
---	---	---



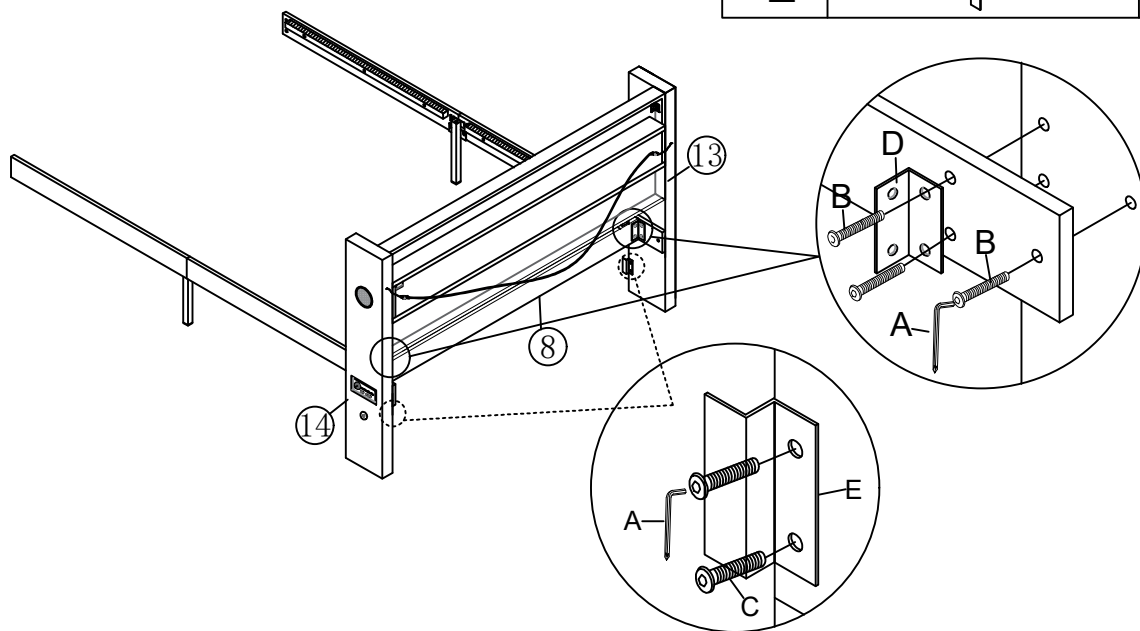

# Schritt 14

A		1
B	 M8X40mm	6
C	 M8X16mm	4
D		2
E		2



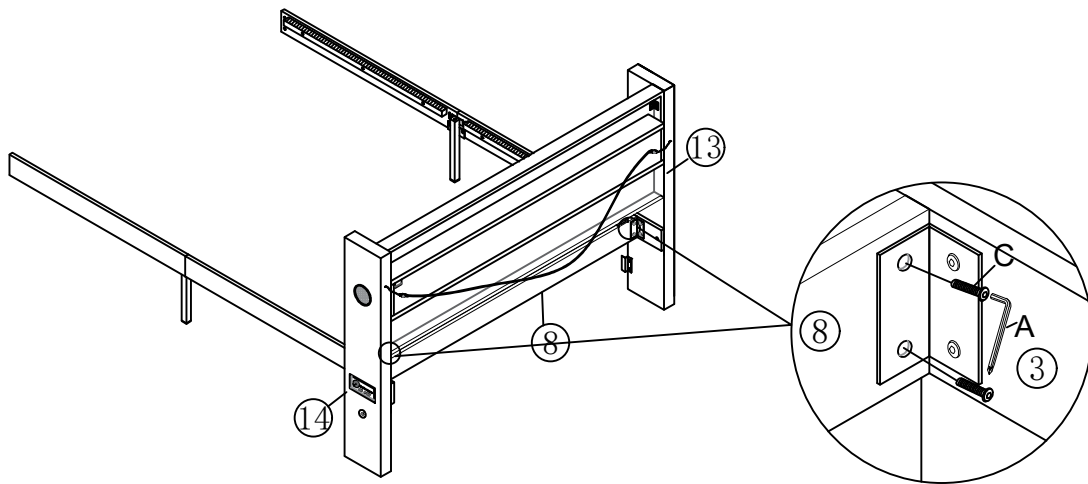

# Schritt 15

A		1
C	 M8X16mm	4



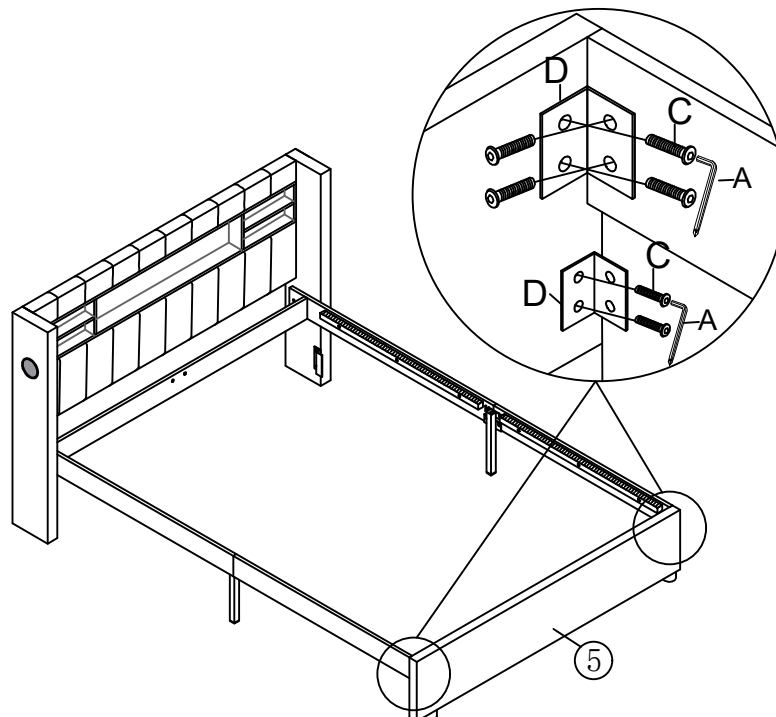

# Schritt 16

A		1
C	 M8X16mm	12
D		4



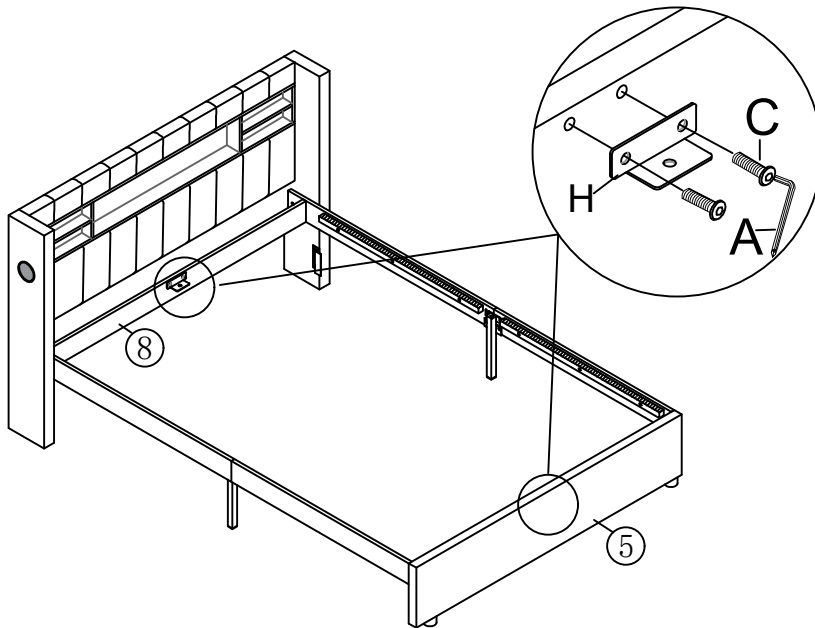

# Schritt 17

A		1
C	 M8X16mm	4
H		2



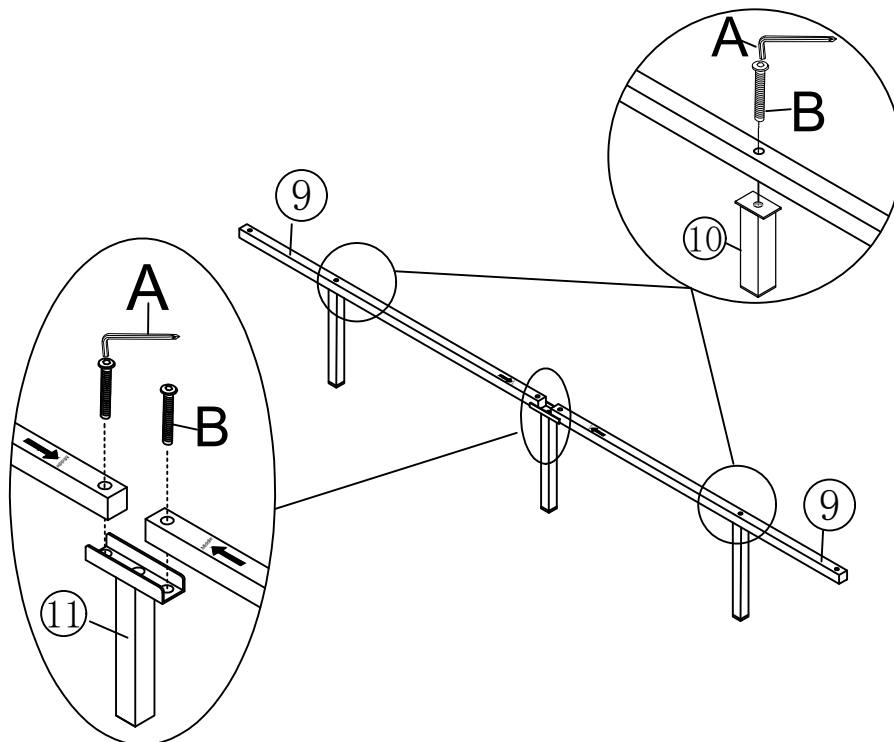

# Schritt 18

A		1
B	 M8X40mm	4



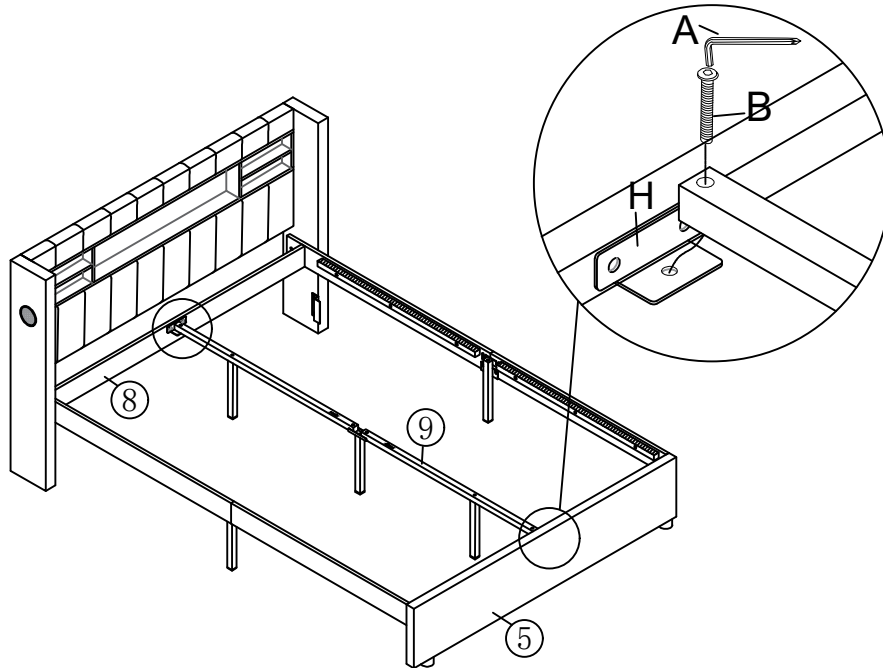

# Schritt 19

A		1
B	 M8X40mm	2



# Schritt 20

A		1
B	 M8X40mm	3

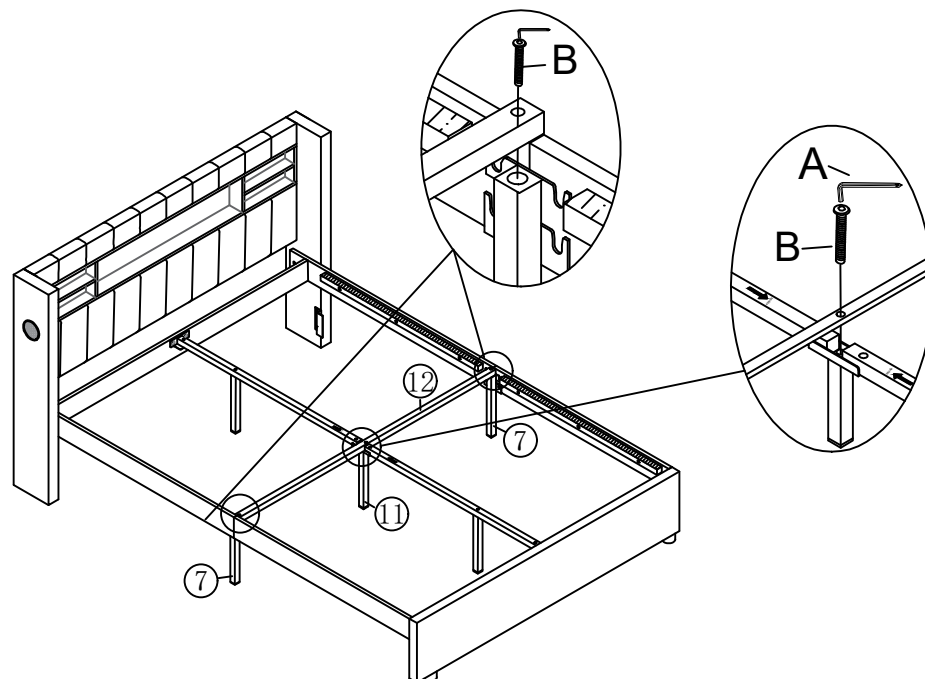



## Schritt 21

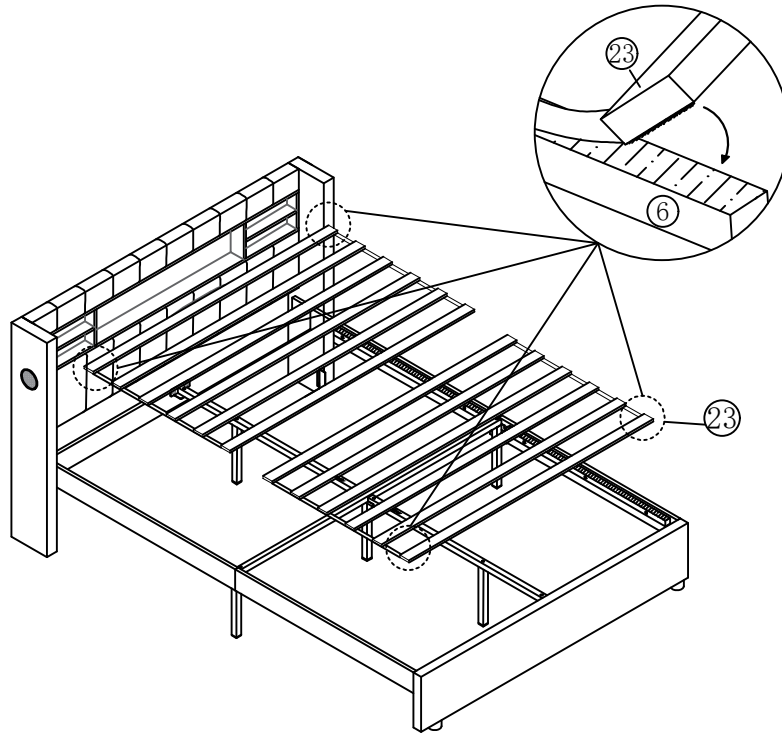

## Schritt 22

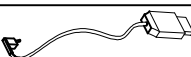
O		1
Q		1

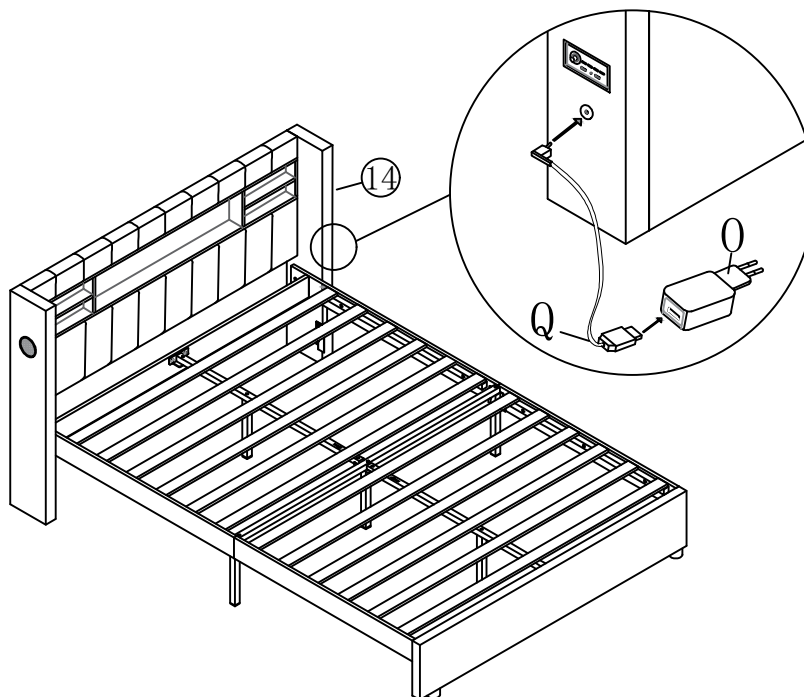

# Schritt 23 x4

Attention:

A		1
C	M8X16mm	12
J		8
K		12
L		16

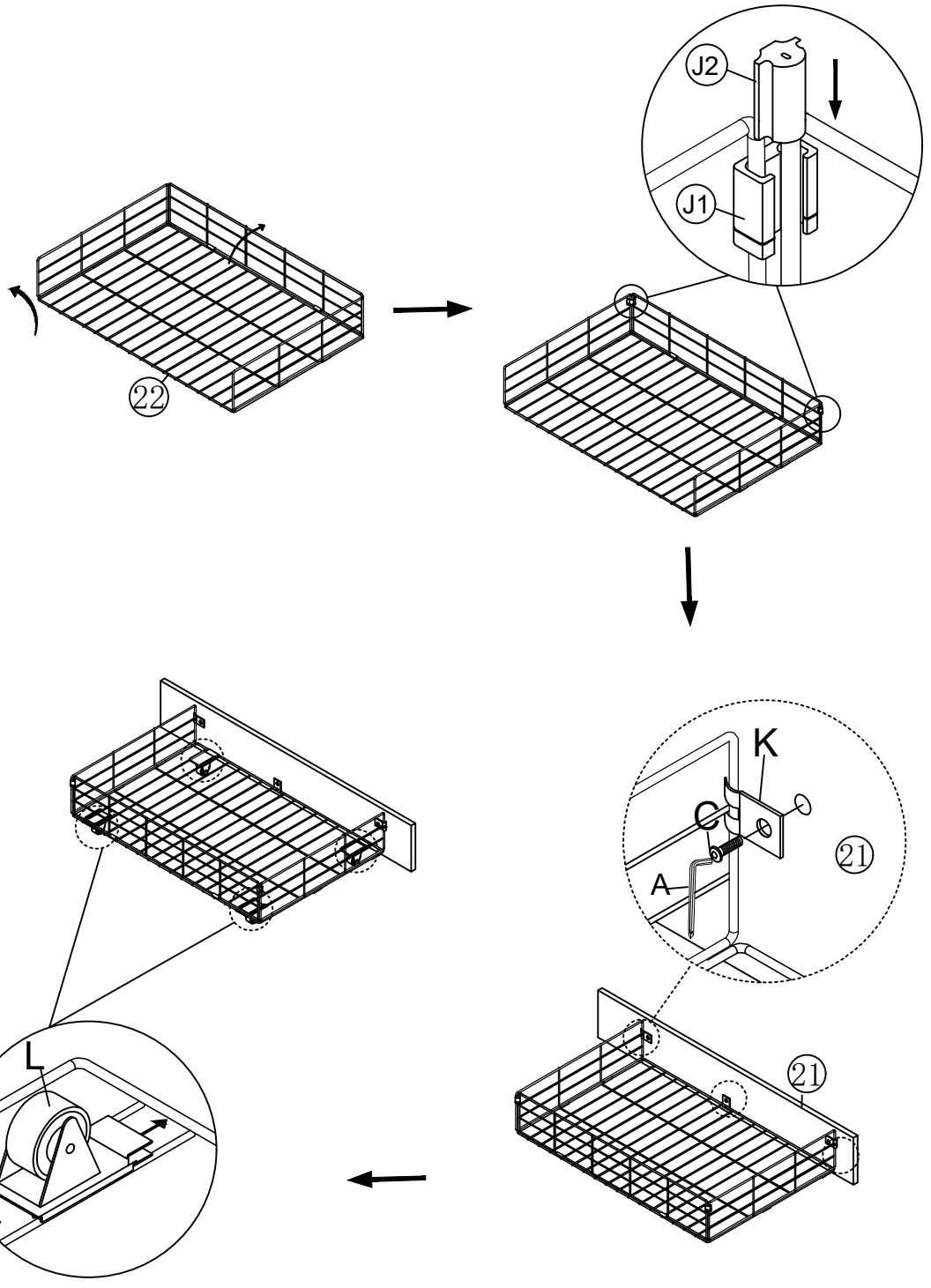

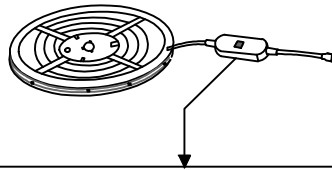
**NOTICE:**

You can scan the QR code here and download an app that can control the color of the light strip like a remote control. When your phone plays music through the app, the color of the light strip will also change according to the strength of the music.

**HINWEIS:**

Sie können den QR-Code hier scannen und eine App herunterladen, mit der Sie die Farbe der Lichtleiste wie mit einer Fernbedienung steuern können. Wenn Ihr Telefon über die App Musik abspielt, ändert sich auch die Farbe der Lichtleiste je nach Stärke der Musik.

