

BAUANLEITUNG

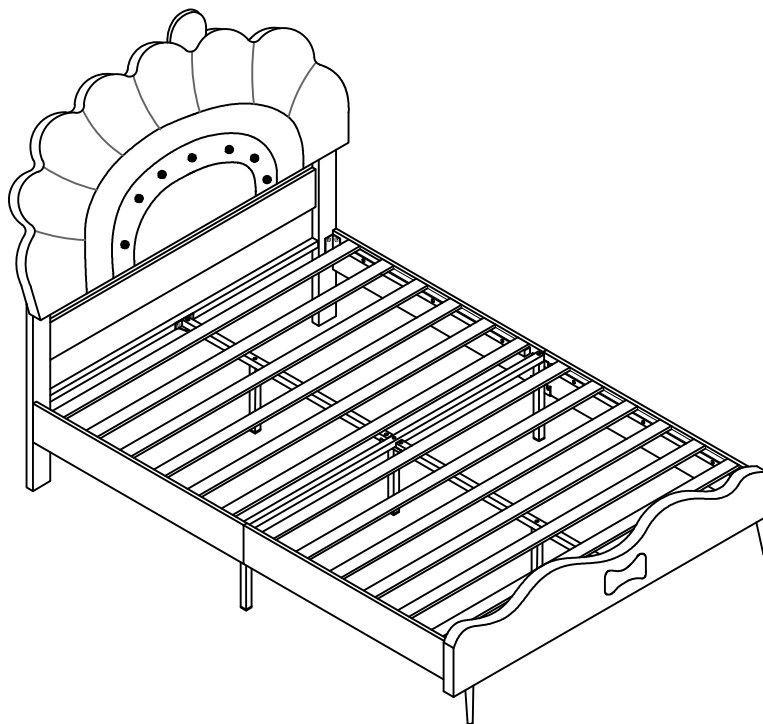

Dieses Set enthält 2 Kartons. Wenn Sie keine vollen 2 Kartons erhalten, wenden Sie sich bitte an unser Kundendienstteam.



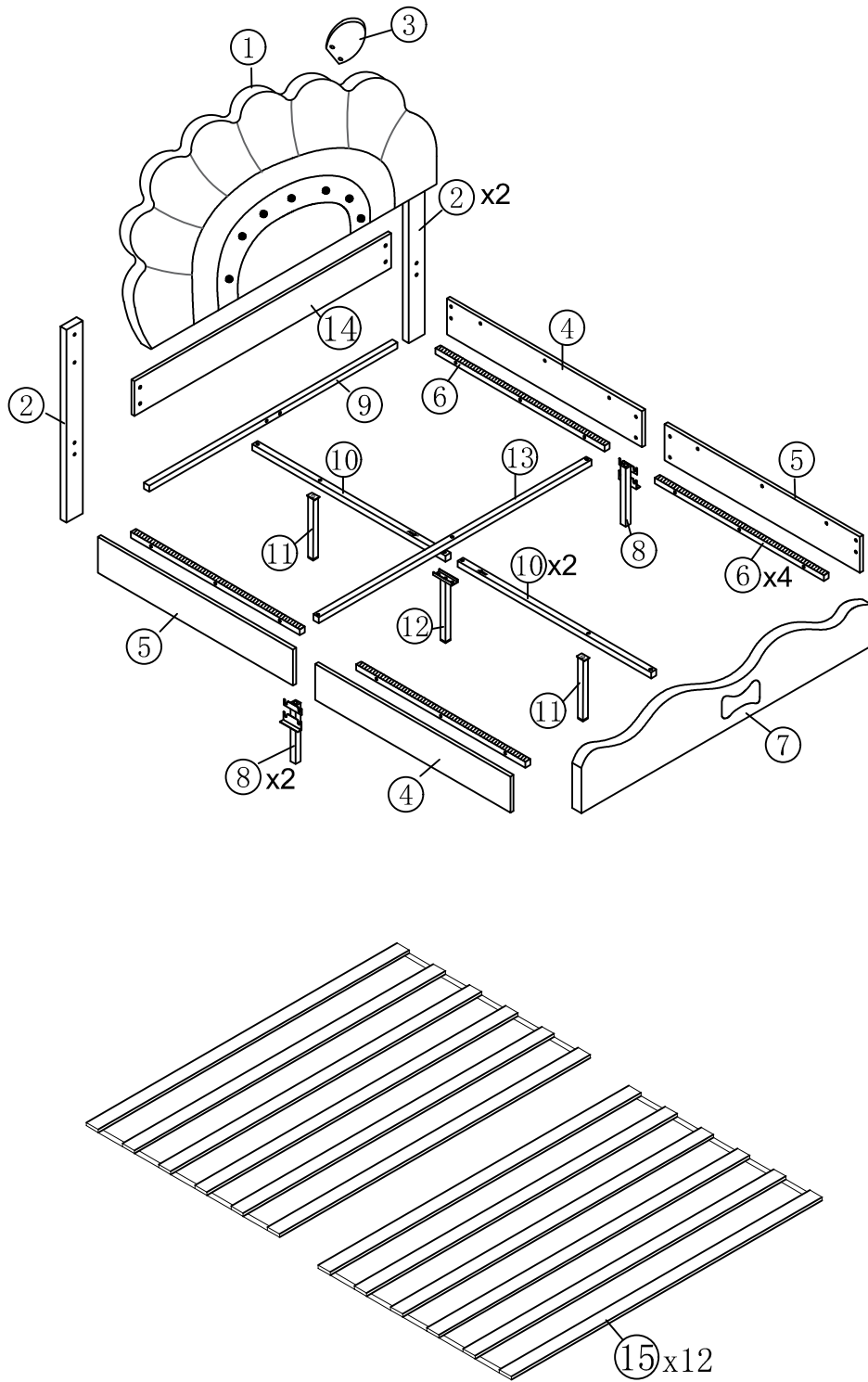

WF321192AAL / WF321193AAL

Detail View



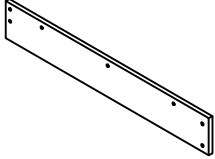
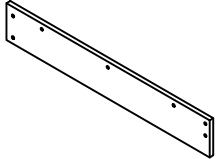
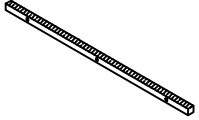
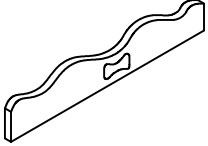

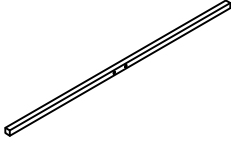
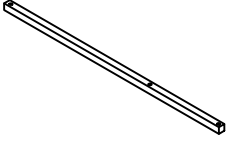
Liste der Einzelteile

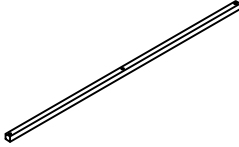
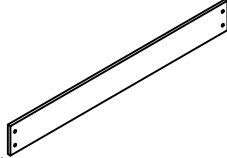
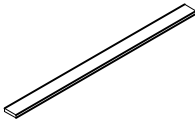
WF321193AAL+ Hardwareliste



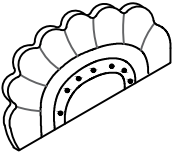







<p>2</p>  <p>Kopfteilbeine-2 Stück</p>	<p>4</p>  <p>Seitenplatte des Bettes - 2 Stück</p>	<p>5</p>  <p>Seitenplatte des Bettes - 2 Stück</p>
<p>6</p>  <p>Seitenschiene-Stützstange-4 Stück</p>	<p>7</p>  <p>Fußbrett-1 Stück</p>	<p>8</p>  <p>Seitenschiene Stützbeine-2 Stück</p>
<p>9</p>  <p>Kopfteil Querstange-1 Stück</p>	<p>10</p>  <p>Stützstange in der Mitte-2 Stück</p>	<p>11</p>  <p>Mittleres Stützbein-2 Stück</p>
<p>12</p>  <p>Mittelbein verbinden-1 Stück</p>	<p>13</p>  <p>Querbalken-1 Stück</p>	<p>14</p>  <p>Kreuzbrett -1 Stück</p>
<p>15</p>  <p>Lamellen-12 Stück</p>		

WF321192AAL

<p>1</p>  <p>Kopfteil-1 Stück</p>	<p>3</p>  <p>Ohr des Kopfteils -1 Stück</p>
---	---

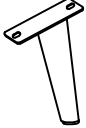

Hardwareliste

WF321193AAL

<p>A</p>  <p>20*70mm</p>	<p>B</p>  <p>Ø8*45mm</p>	<p>C</p>  <p>Ø8*16mm</p>
<p>Inbusschlüssel(1 Stück)</p>	<p>Schrauben(4 Stück)</p>	<p>Schrauben(44 Stück)</p>
<p>D</p>  <p>Ø8*30mm</p>	<p>E</p>  <p>Ø8*40mm</p>	<p>F</p>  <p>77*33**33*2mm</p>
<p>Schrauben(2 Stück)</p>	<p>Schrauben(21 Stück)</p>	<p>"7"-Anschluss(4 Stück)</p>
<p>G</p> 	<p>H</p>  <p>100*100*2mm</p>	<p>I</p> 
<p>Dreizackige Metallfüße</p>	<p>Vier-Loch-Eisen(2 Stück)</p>	<p>Zweiloch-Eisenblech(2 Stück)</p>
<p>J</p>  <p>28*32*86*2mm</p> <p>Beschläge für mittlere Stützstange(2 Stück)</p>		



Hinweis: Wir empfehlen Ihnen, Ihr Bett im ebenen Boden aufzubauen.

Schritt 1

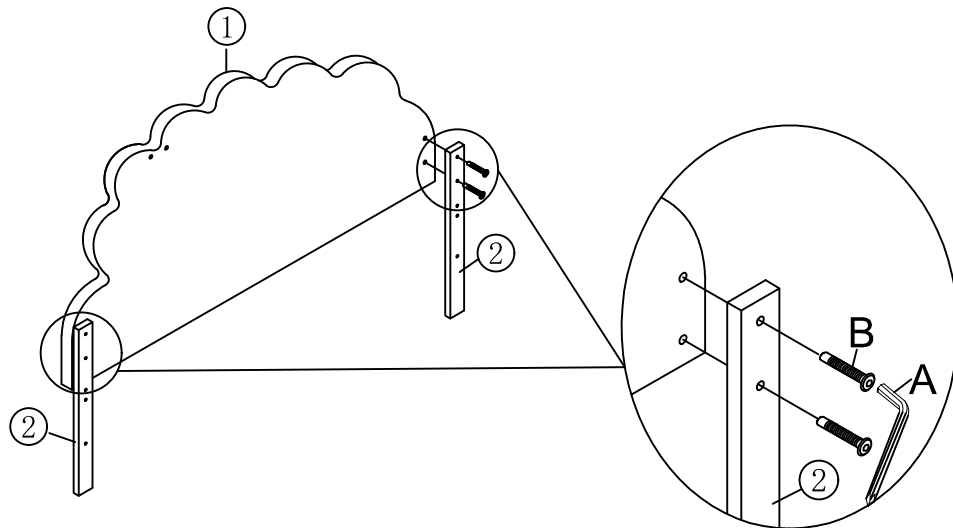
A	B
	 M8X45mm
	4Stück



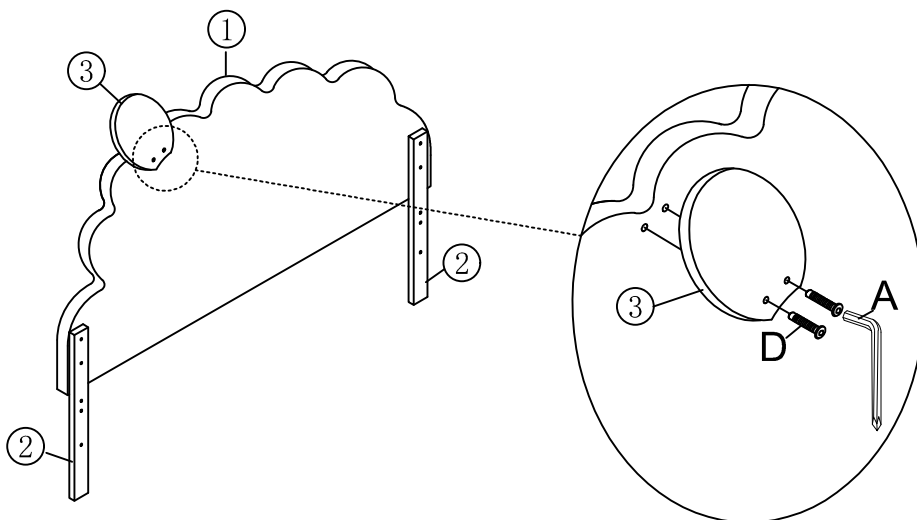

Schritt 2

A	D
	 M8X30mm
	2Stück



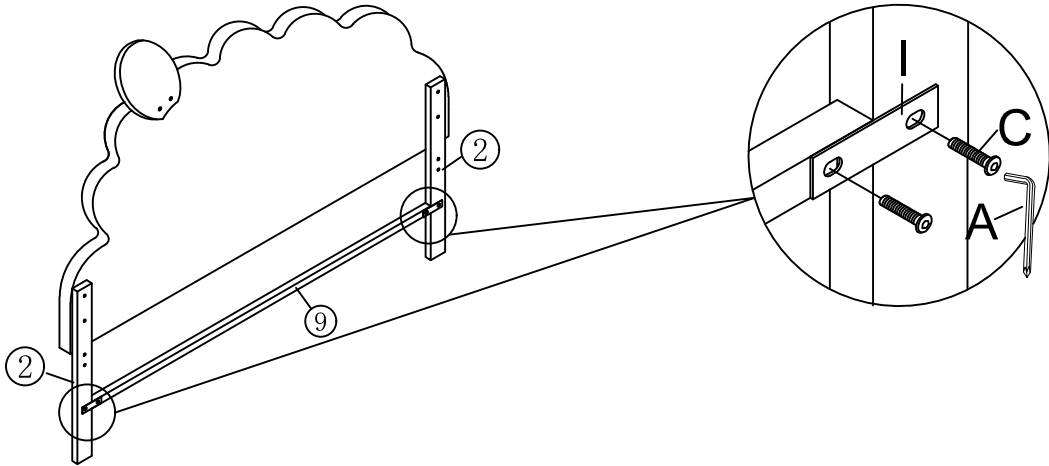

Schritt 3

A	C	I
	 M8X16mm	
	4Stück	2Stück



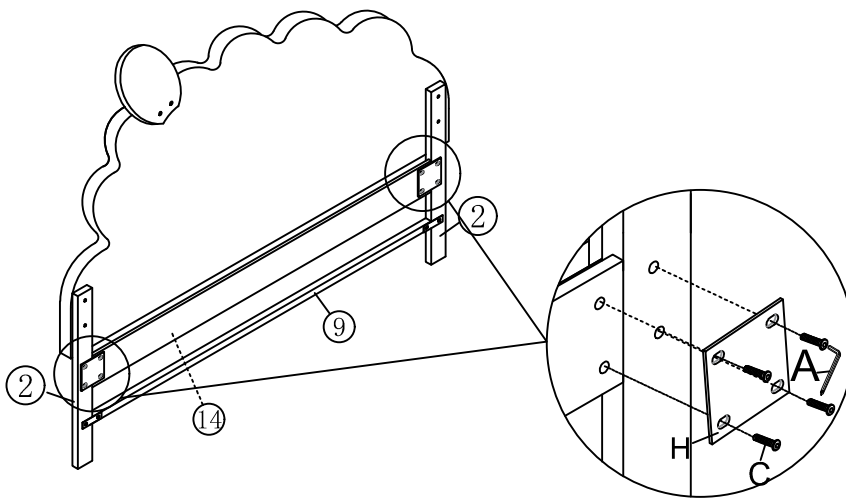

Schritt 4

A	C	H
	 M8X16mm	
	8Stück	2Stück



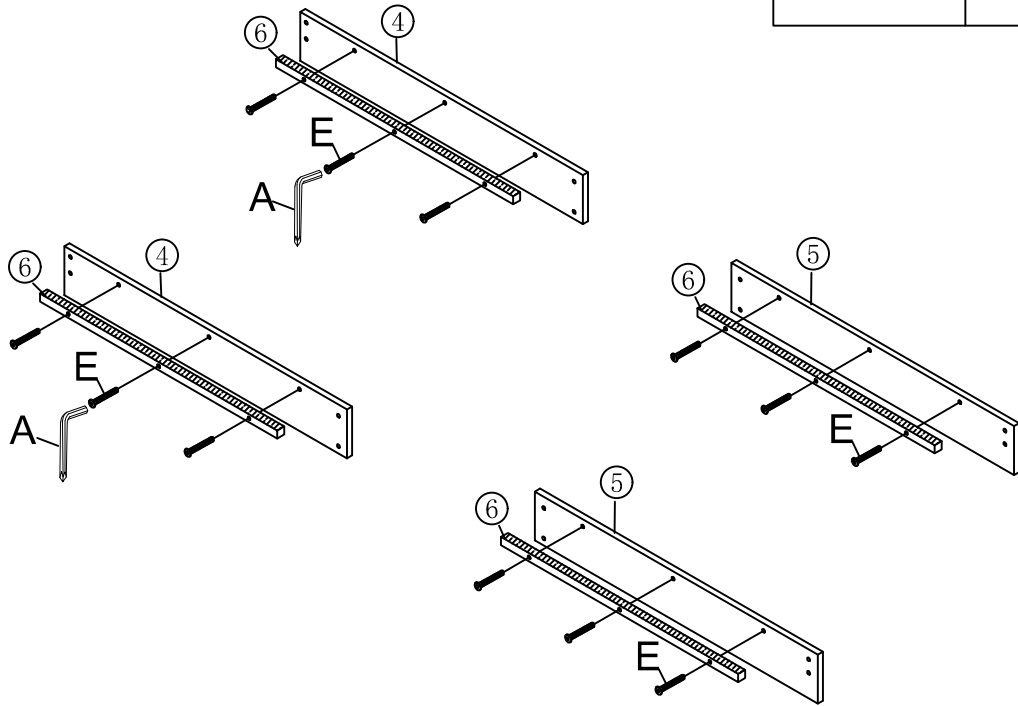

Schritt 5

A	E
	
	M8X40mm
	12Stück



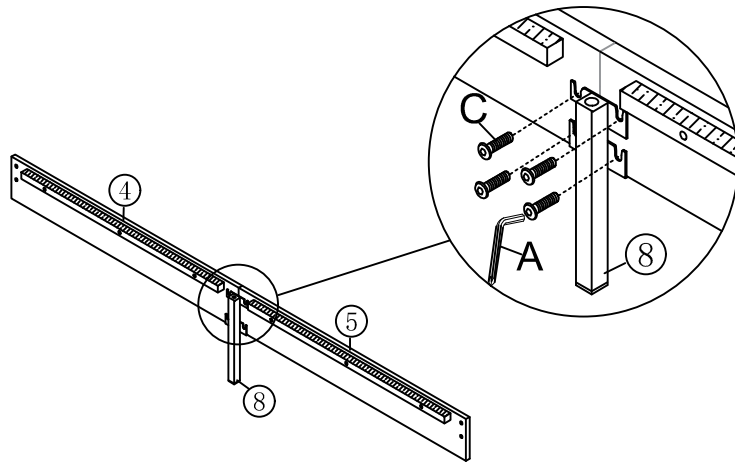

Schritt 6 x2

A	C
	
	M8X16mm
	8Stück



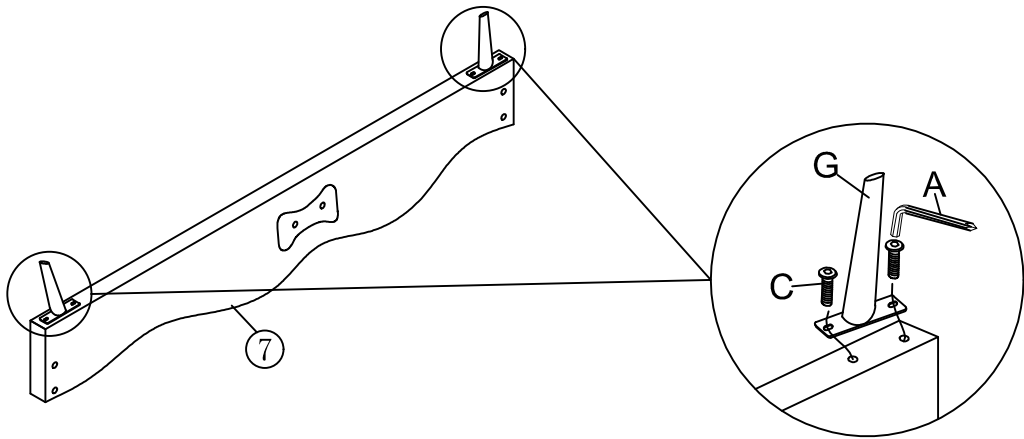

Schritt 7

A	C	G
	M8X16mm 	
4Stück		2Stück



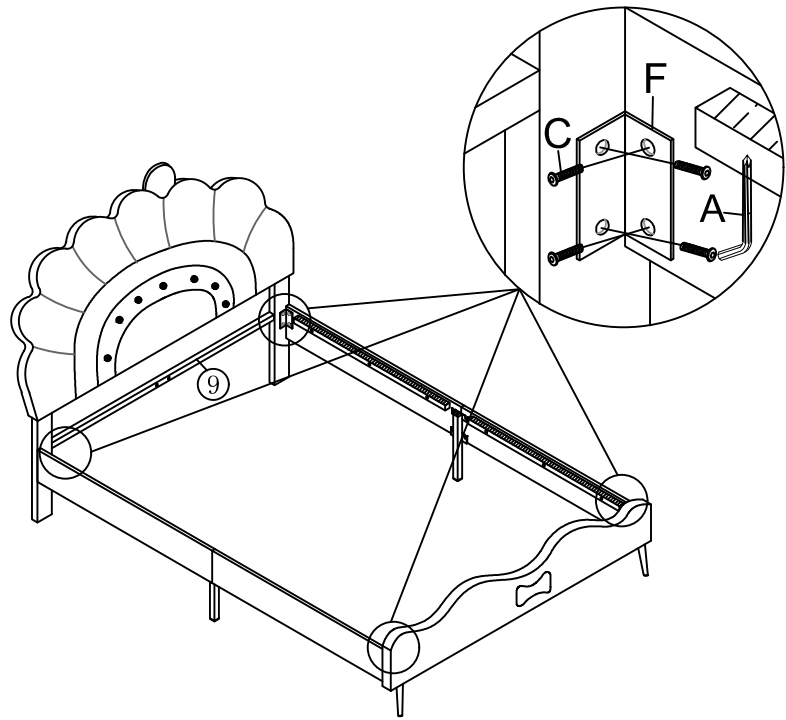

Schritt 8

A	C	F
	M8X16mm 	
16Stück		4Stück



Schritt 9

A	C	J
	 M8X16mm	
	4Stück	2Stück

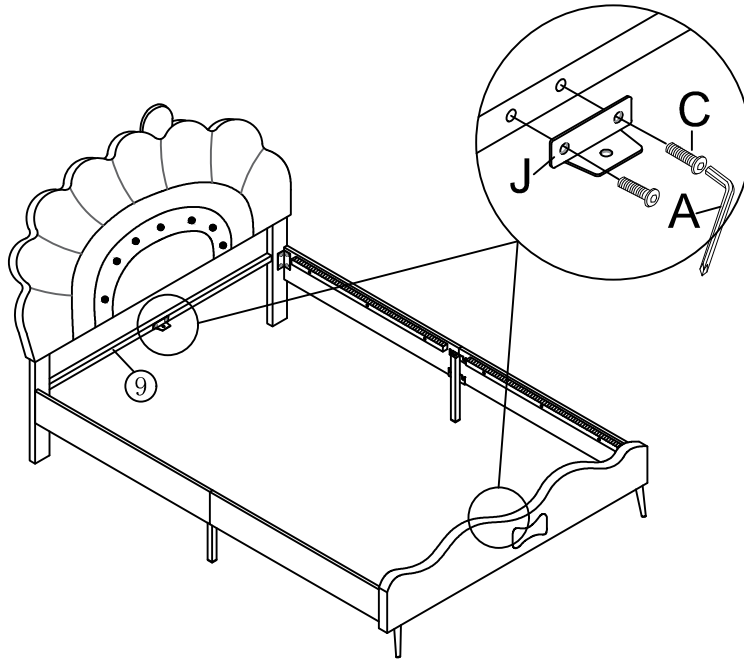

Schritt 10

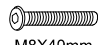
A	E
	 M8X40mm
	4Stück

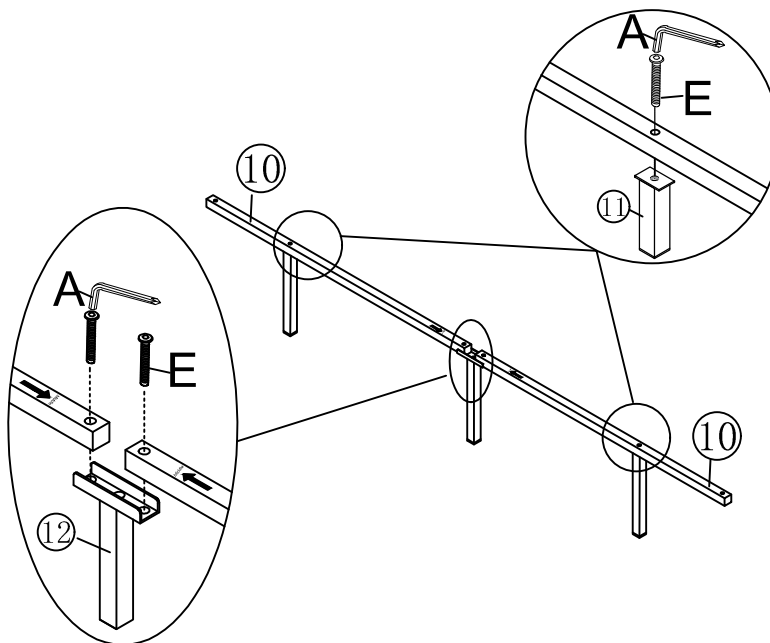

Schritt 11

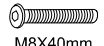
A	E
	 M8X40mm
	2Stück

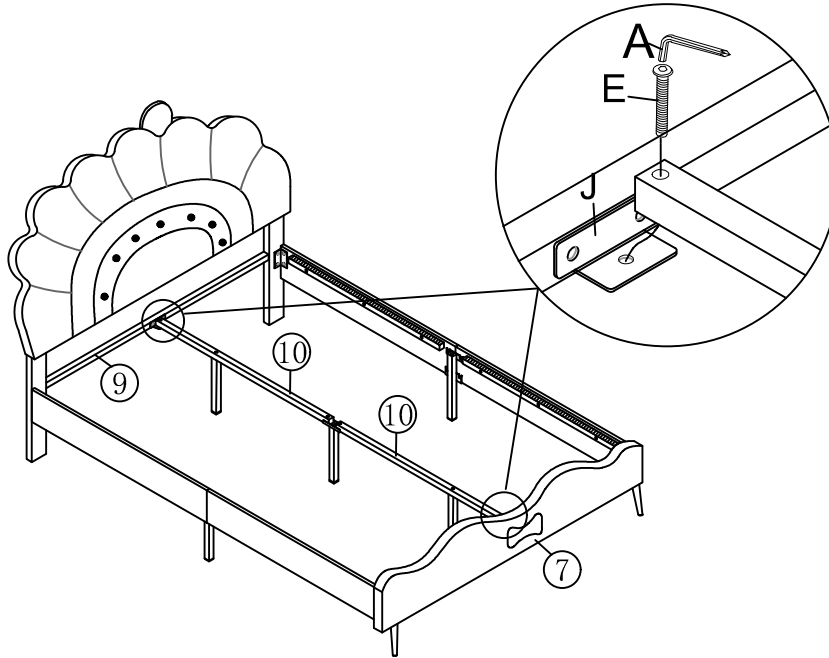

Schritt 12

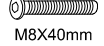
A	E
	 M8X40mm
	3Stück

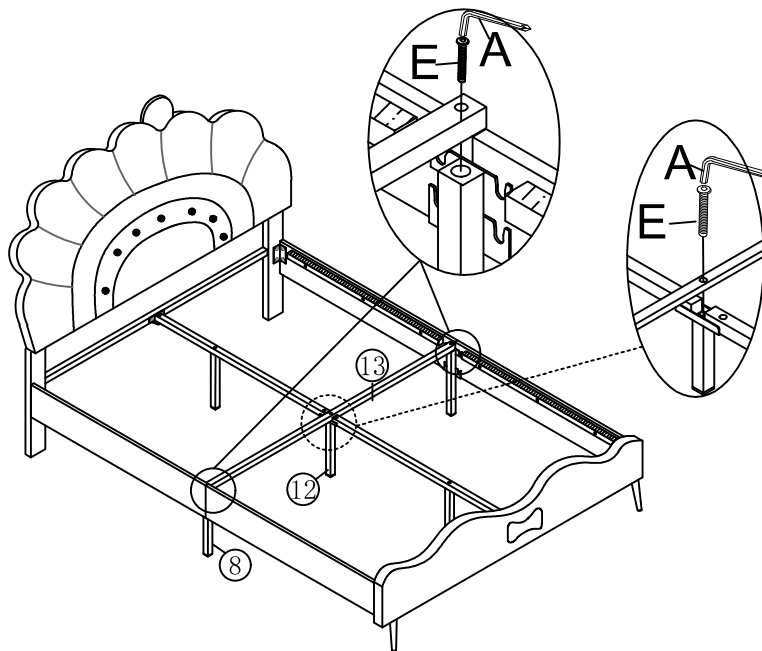

Schritt 13

