

# MISTRAL

- design for your life

## M31

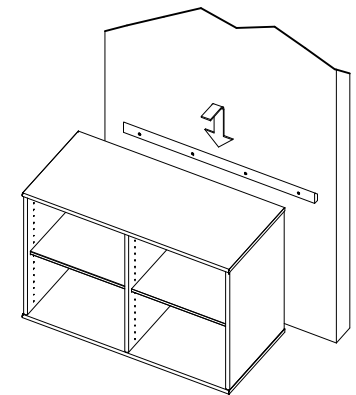
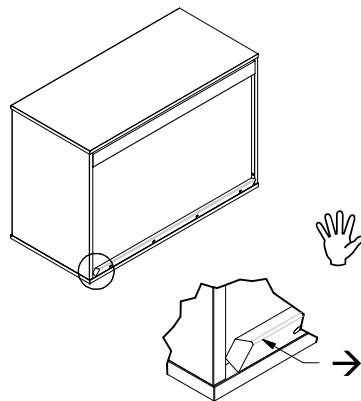
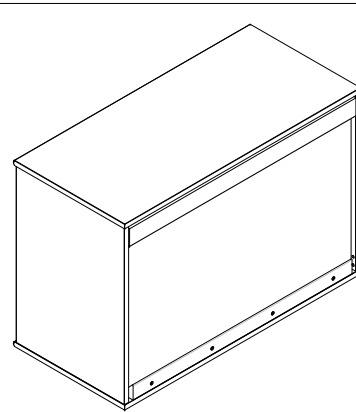
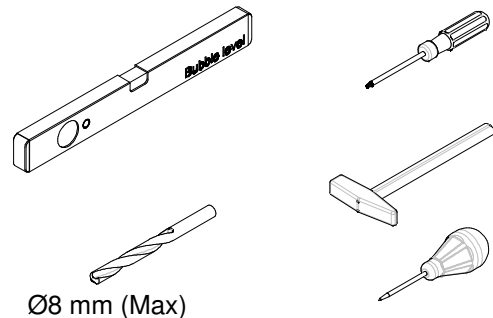
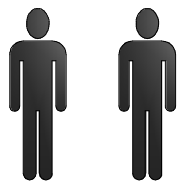
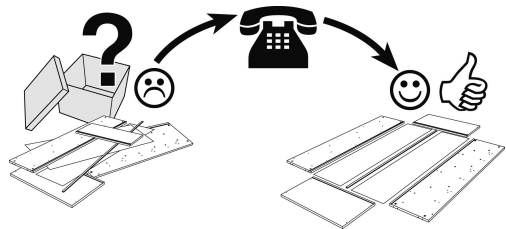
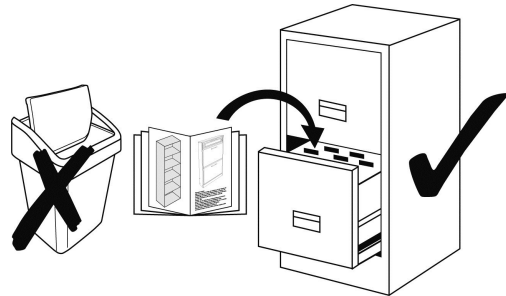

Ø5 x 70 mm  
(6500570)

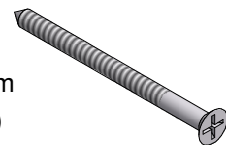

31002-E11-P1 /4

!

**DK** Ved ophængning af modul skal De selv sikre Dem væggenes beskaffenhed. Vort ansvar dækker kun den belastning, som selve reolen kan bære. Er De i tvivl kontakt da venligst en fagmand.

**GB** Before wall mounting of the modules, you have to make sure of the character of the wall. We are only responsible for the carrying capacity of the modules. In case of doubt, please contact an expert.

**D** Vor Aufhängen der Elemente müssen Sie die Beschaffenheit der Wand sichern. Wir tragen nur die Verantwortung für die Belastungsfähigkeit der Elemente. Im Zweifelsfall, wenden Sie sich bitte an einen Fachmann.

**FR** En suspension de l'étagère, vous êtes responsable de la qualité du mur. Notre responsabilité ne comprend que le poids que l'étagère peut supporter. En cas de doute, veuillez consulter un expert.

**IT** Prima di montare lo scaffale è tua responsabilità assicurarti di aver scelto una parete adatta a tale scopo. Noi siamo responsabili solamente per la capacità di carico dello scaffale. In caso di dubbi contatta uno specialista.

**NL** Bij het monteren van het schap bent u ervoor verantwoordelijk dat de wand geschikt is voor het beoogde doel. We zijn alleen verantwoordelijk voor de belasting die de plank zelf kan dragen. Neem bij twijfel contact op met een specialist.

**PL** Podczas montażu półki należy upewnić się, że ściana jest odpowiednia do zaplanowanego zastosowania. Nasza firma jest odpowiedzialna wyłącznie za obciążenie, jakie może wytrzymać sama półka. W przypadku wątpliwości należy skontaktować się ze specjalistą.

**CZ** Při montáži poličky zodpovídáte za to, že zkontrolujete, že stěna je vhodná pro zamýšlený účel. Neseme zodpovědnost pouze za to, že polička unese zatížení, které dokáže unést. V případě pochybností kontaktujte odborníka.

**SK** Pri sestavljanju police ste odgovorni za to, da se prepričate, ali je stena primerna za predvideni namen. Mi smo odgovorni le za obremenitev same police. V primeru dvoma se obrnite na strokovnjaka.

**HU** A polc felszerelése során Önnek kell meggyőződnie arról, hogy a fal alkalmas erre a célra. Cégünk csak azért a terhelésért vállal felelősséget, amelyet a polc elbír. Kérdés esetén forduljon szakemberhez.

**RO** Când asamblați raftul, dvs. sunteți responsabil să vă asigurați că peretele este potrivit pentru acest scop. Noi suntem responsabili doar pentru greutatea pe care raftul o poate suporta. În cazul în care aveți nelămuriri, vă rugăm să contactați un specialist.

**TR** Rafi birleştirilmesinde, duvarın amaca uygun olmasını güvence altına almalısınız. Bizim tek sorumlu olduğumuz nokta, rafın kaldırabileceği yüküdür. Sizi rahatsız neden bir nokta olduğunda, lütfen bir uzmanla irtibata geçin.

**RU** При монтаже полки, вы ответственны за выбор стены, пригодной для назначенной цели. Мы несем ответственность исключительно за нагрузку, которую способна выдержать сама полка. Если у вас возникли сомнения, пожалуйста, свяжитесь со специалистом.

**SV** Vid upphängning på väggen skall ni först och främst säkerställa väggens hållbarhet/skick. Vårt ansvar täcker endast modulens hållbarhet/viktbelastning enligt informationen. Är ni osäkra på väggens hållbarhet är det rekommenderat att ni kontaktar en fackman.

Max.  
20 kg.

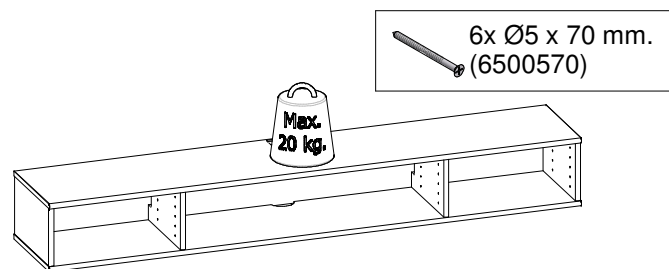
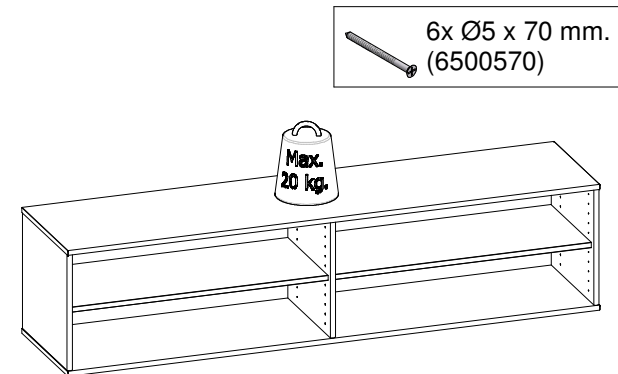
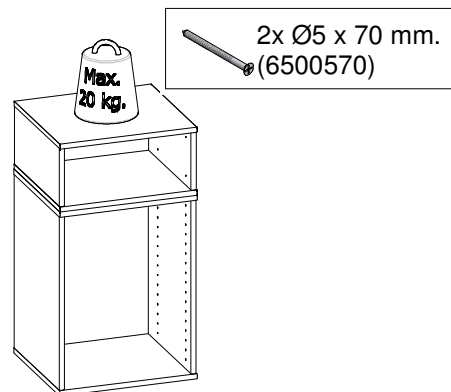
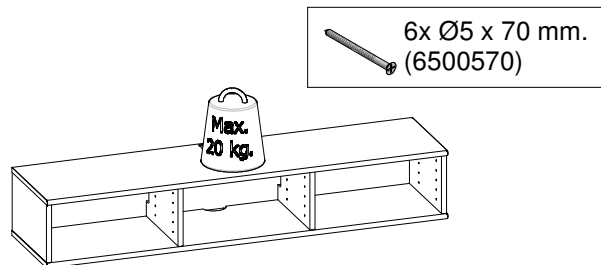
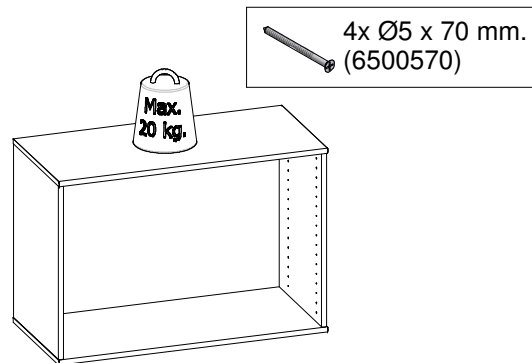
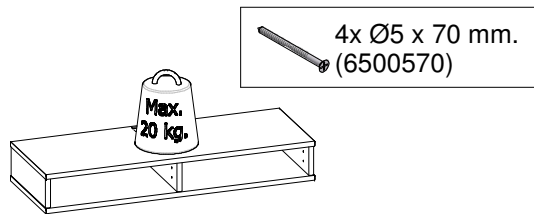

Max.  
40 kg.

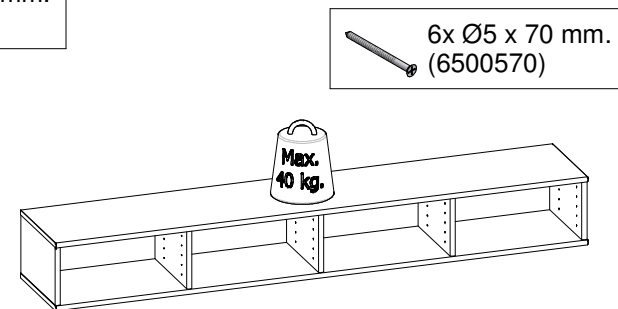
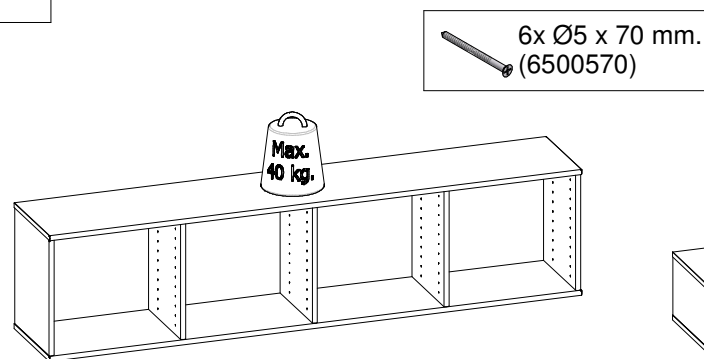
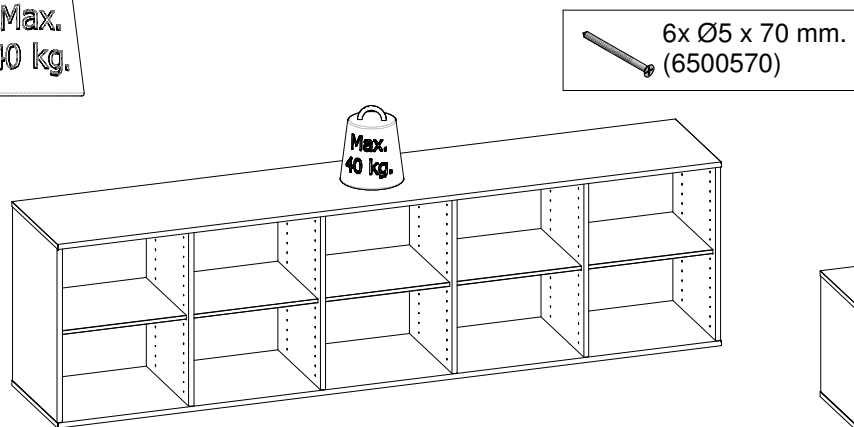

# MISTRAL

- design for your life

## M31

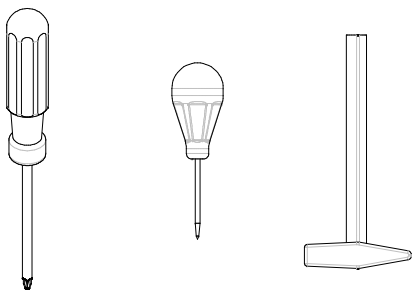
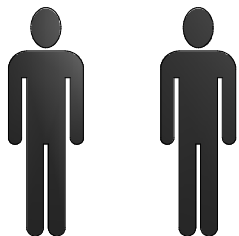

18 x Ø3,5 x 12  
(6500213)

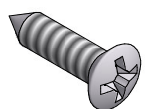

24 x Ø4,5 x 16  
(3012377)

31002-E11-P3 /4

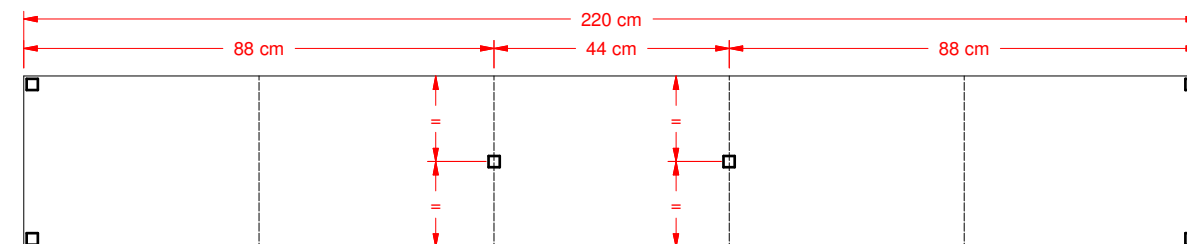
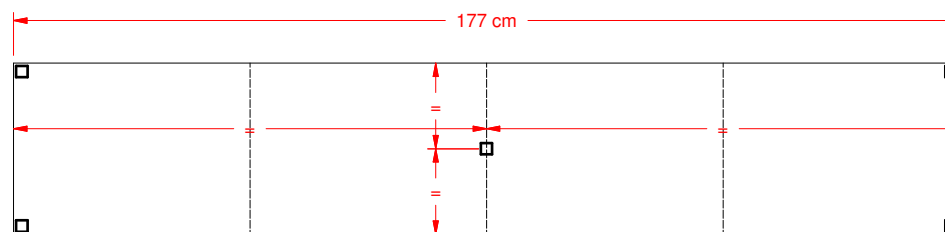
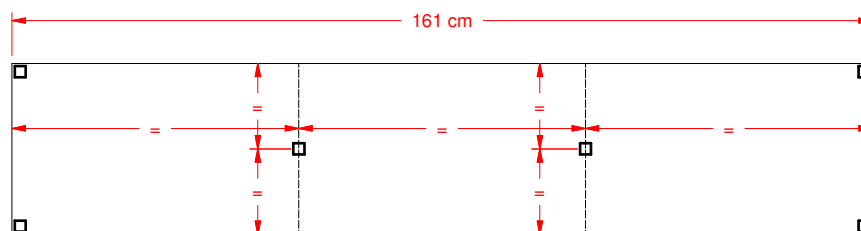
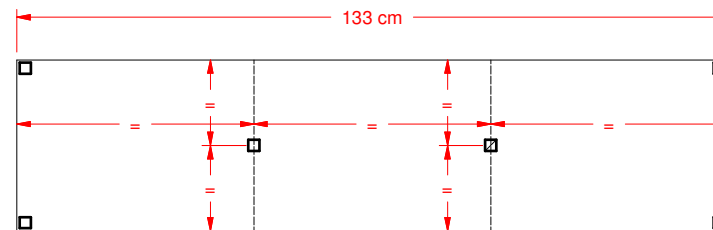
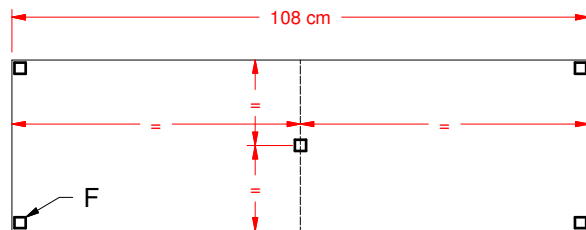
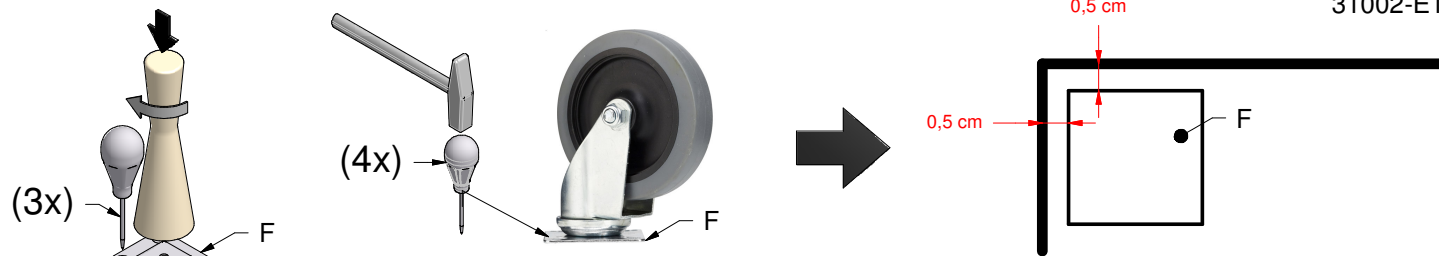

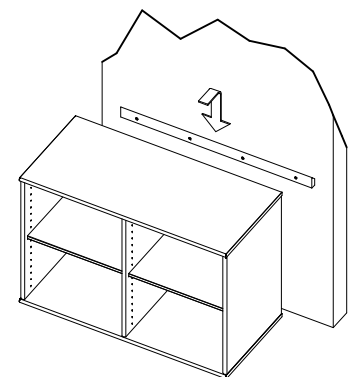
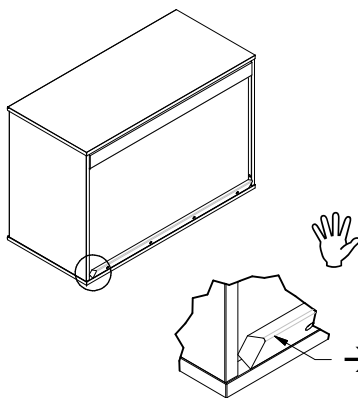
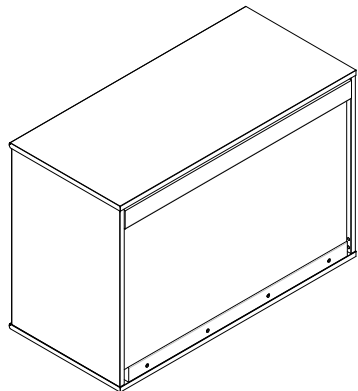

Ø5 x 70 mm  
(6500570)

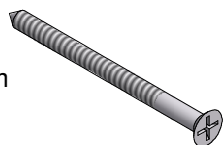

**DK** Ved ophængning af modul skal De selv sikre Dem væggen beskaffenhed. Vort ansvar dækker kun den belastning, som selve reolen kan bære. Er De i tvivl kontakt da venligst en fagmand.

**GB** Before wall mounting of the modules, you have to make sure of the character of the wall. We are only responsible for the carrying capacity of the modules. In case of doubt, please contact an expert.

**D** Vor Aufhängen der Elemente müssen Sie die Beschaffenheit der Wand sichern. Wir tragen nur die Verantwortung für die Belastungsfähigkeit der Elemente. Im Zweifelsfall, wenden Sie sich bitte an einen Fachmann.

**FR** En suspension de l'étagère, vous êtes responsable de la qualité du mur. Notre responsabilité ne comprend que le poids que l'étagère peut supporter. En cas de doute, veuillez consulter un expert.

**IT** Prima di montare lo scaffale è tua responsabilità assicurarti di aver scelto una parete adatta a tale scopo. Noi siamo responsabili solamente per la capacità di carico dello scaffale. In caso di dubbi contatta uno specialista.

**NL** Bij het monteren van het schap bent u ervoor verantwoordelijk dat de wand geschikt is voor het beoogde doel. We zijn alleen verantwoordelijk voor de belasting die de plank zelf kan dragen. Neem bij twijfel contact op met een specialist.

**PL** Podczas montażu półki należy upewnić się, że ściana jest odpowiednia do zaplanowanego zastosowania. Nasza firma jest odpowiedzialna wyłącznie za obciążenie, jakie może wytrzymać sama półka. W przypadku wątpliwości należy skontaktować się ze specjalistą.

**CZ** Při montáži poličky zodpovídáte za to, že zkontrolujete, že stěna je vhodná pro zamýšlený účel. Neseme zodpovědnost pouze za to, že polička unese zatížení, které dokáže unést. V případě pochybností kontaktujte odborníka.

**SK** Pri sestavljanju police ste odgovorni za to, da se prepričate, ali je stena primerna za predvideni namen. Mi smo odgovorni le za obremenitev same police. V primeru dvoma se obrnite na strokovnjaka.

**HU** A polc felszerelése során Önnek kell meggyőződnie arról, hogy a fal alkalmas erre a célra. Cégünk csak azért a terhelésért vállal felelősséget, amelyet a polc elbír. Kérdés esetén forduljon szakemberhez.

**RO** Când asamblați raftul, dvs. sunteți responsabil să vă asigurați că peretele este potrivit pentru acest scop. Noi suntem responsabili doar pentru greutatea pe care raftul o poate suporta. În cazul în care aveți nelămuriri, vă rugăm să contactați un specialist.

**TR** Rafi birleştirirkenizde, duvarın amaca uygun olmasını güvence altına almalsınız. Bizim tek sorumlu olduğumuz nokta, rafın kaldıracılabileceği yüküdür. Sizi rahatsız neden bir nokta olduğunda, lütfen bir uzmanla irtibata geçin.

**RU** При монтаже полки, вы ответственны за выбор стены, пригодной для назначенной цели. Мы несем ответственность исключительно за нагрузку, которую способна выдержать сама полка. Если у вас возникли сомнения, пожалуйста, свяжитесь со специалистом.

**SV** Vid upphängning på väggen skall ni först och främst säkerställa väggens hållbarhet/skick. Vårt ansvar täcker endast modulens hållbarhet/viktbelastning enligt informationen. Är ni osäkra på väggens hållbarhet är det rekommenderat att ni kontaktar en fackman.

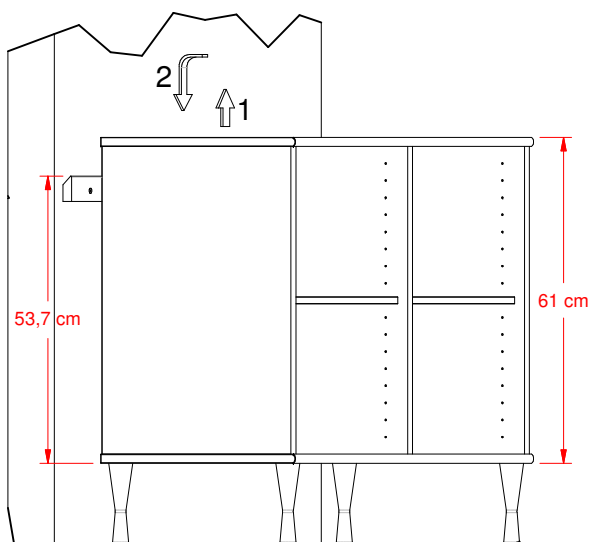
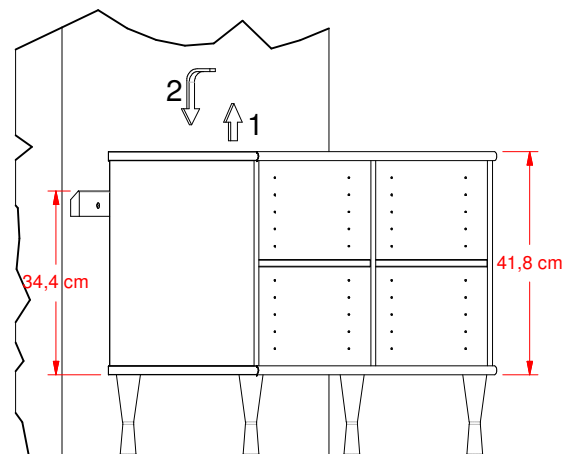

31002-E11-P4 /4

**DK** Vægfastgørelsen forhindrer fald - vær sikker på at montere den! For visse vægtyper kan det være nødvendigt med en speciel rawplug!

**GB** The wall fastening serves to prevent tipping - be absolutely sure to mount it! For certain wall types, a special wall plug may be necessary!

**D** Wandbefestigung dient als Kippschutz - unbedingt anbringen! Bei einigen Wandtypen kann ein Spezialdübel erforderlich sein!

**FR** La fixation murale sert de protection contre le basculement - à installer impérativement! Pour certains types de murs il faut des chevilles spéciales!

**IT** Il fissaggio alla parete serve da protezione anti-ribaltamento - attaccarla assolutamente! Per alcune strutture di parete può essere necessario un tassello speciale!

**NL** Bevestiging aan de muur dient als kantelbescherming - zeker en vast bevestigen! Bij enkele muurtypen is een speciale plugmisschien vereist!

**PL** Mocowanie do ściany jest jednocześnie zabezpieczeniem przed przewróceniem - koniecznie zamontować! Do niektórych rodzajów ścian koniecznie zastosować specjalne kołki mocujące.

**CZ** Montáž na stěnu slouží jako ochrana proti převrnutí - bezpodmínečně umístit! U některých typů stěn může být zapotřebí speciální hmoždinka!

**SK** Upevnenie na stenu slúži ako ochrana proti prevráteniu - bezpodmienečne použite! Pre niektoré druhy stien môže byť potrebná špeciálna hmoždinka!

**HU** A terméket a falhoz kel rögzíteni, különben az felborulhat! Egyes faltípusoknál speciális tiplilt kell használni!

**RO** Sistemul de fixare la perete servește ca protecție la răsturnare - de montat obligatoriu! Pentru unele tipuri de pereți este posibil să fie necesar un diblu special!

**TR** Duvardaki sabitleme, devrilmeye karşı bir emniyet tedbiridir ve mutlaka monte edilmelidir! Bazi duvar tiplerinde bunun için özel bir dübel gerekli olabilir!

**RU** Обязательно установите крепление на стене во избежание опрокидывания! Для некоторых типов стен может потребоваться специальный дюбель!

**SV** Väggfästet förhindrar fall - se till att montera det! För vissa väggtyper måste en speciell väggplugg användas.

## M31 Skuffer / Drawers / Schubladen / Tiroirs

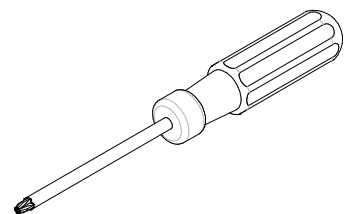

PZ2

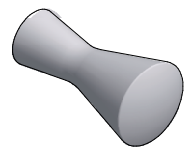
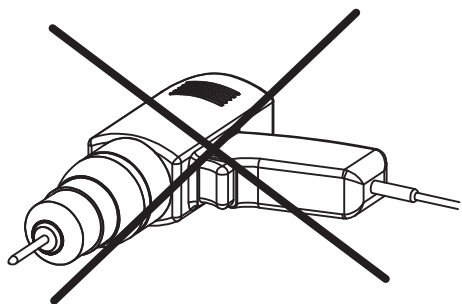

F1 x 1  
(4005361)

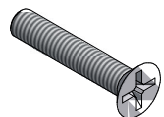

F2 x 1  
(6704422)



F3 x 4  
(6700502)

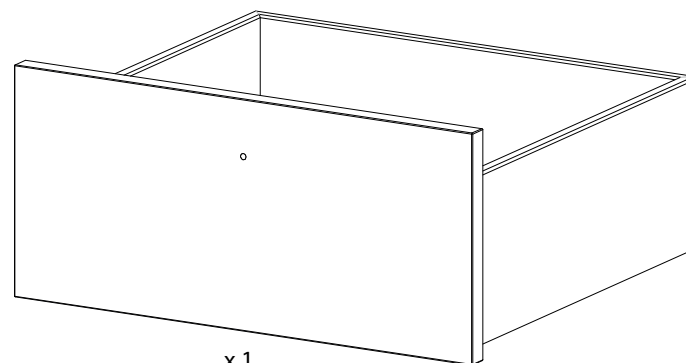

x 1

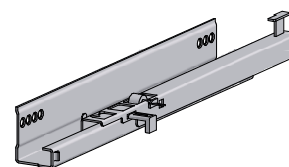

F4L x 1  
(6408 650)

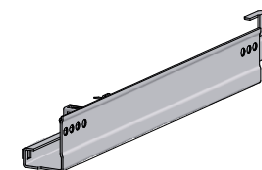

F4R x 1  
(6408650)

1

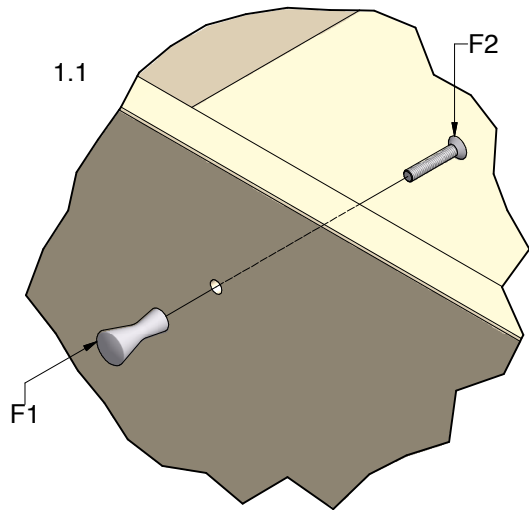
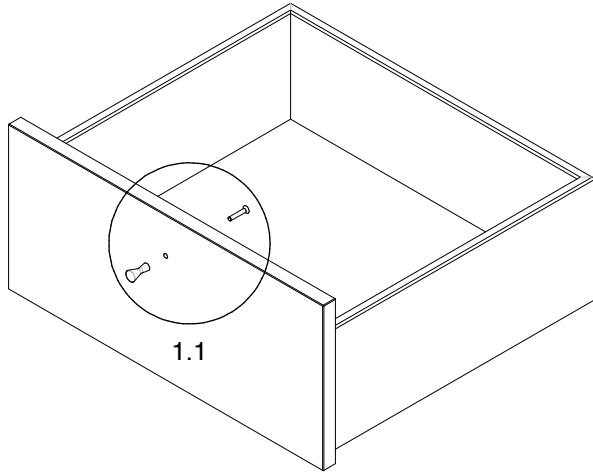

2

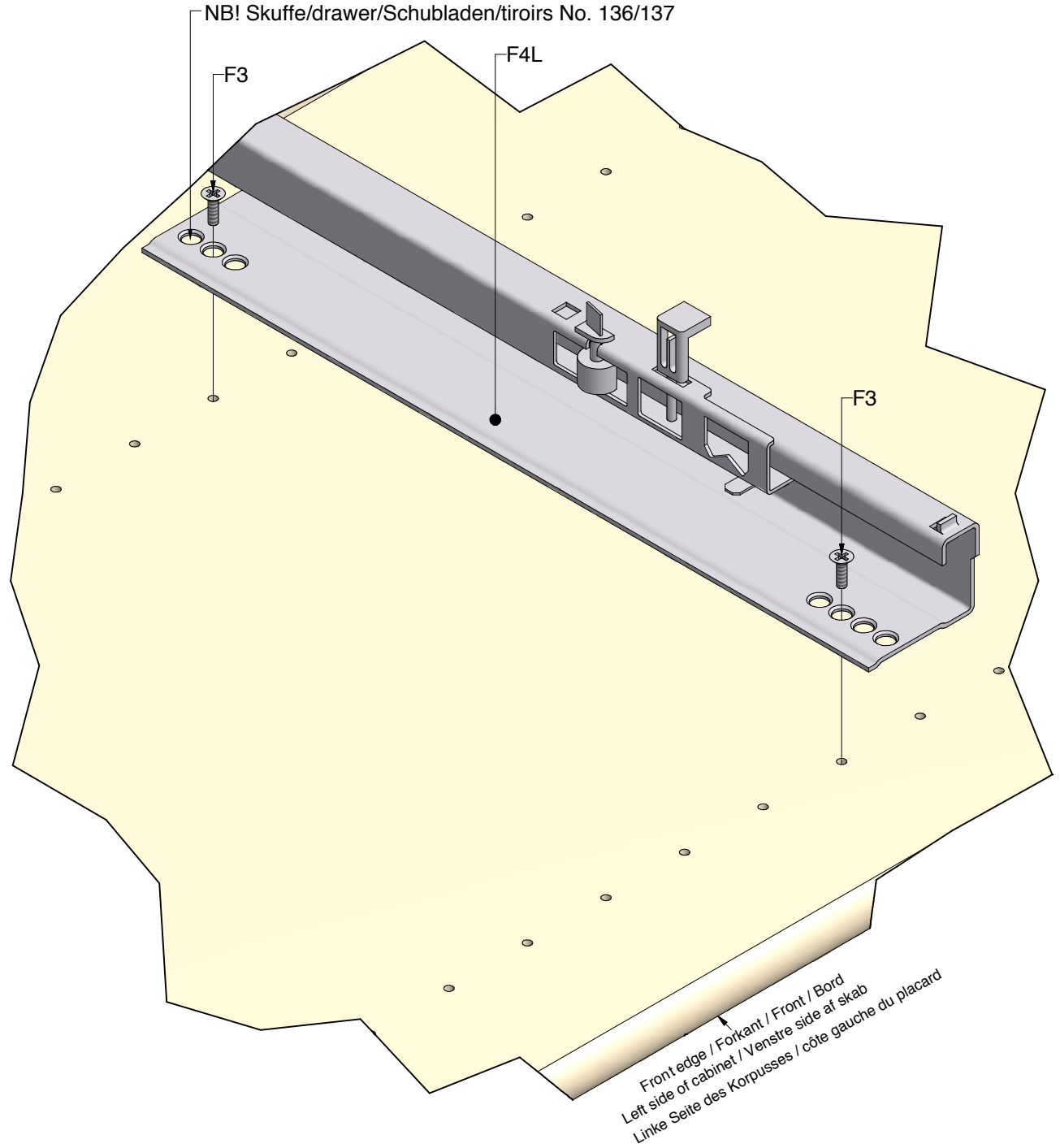

3

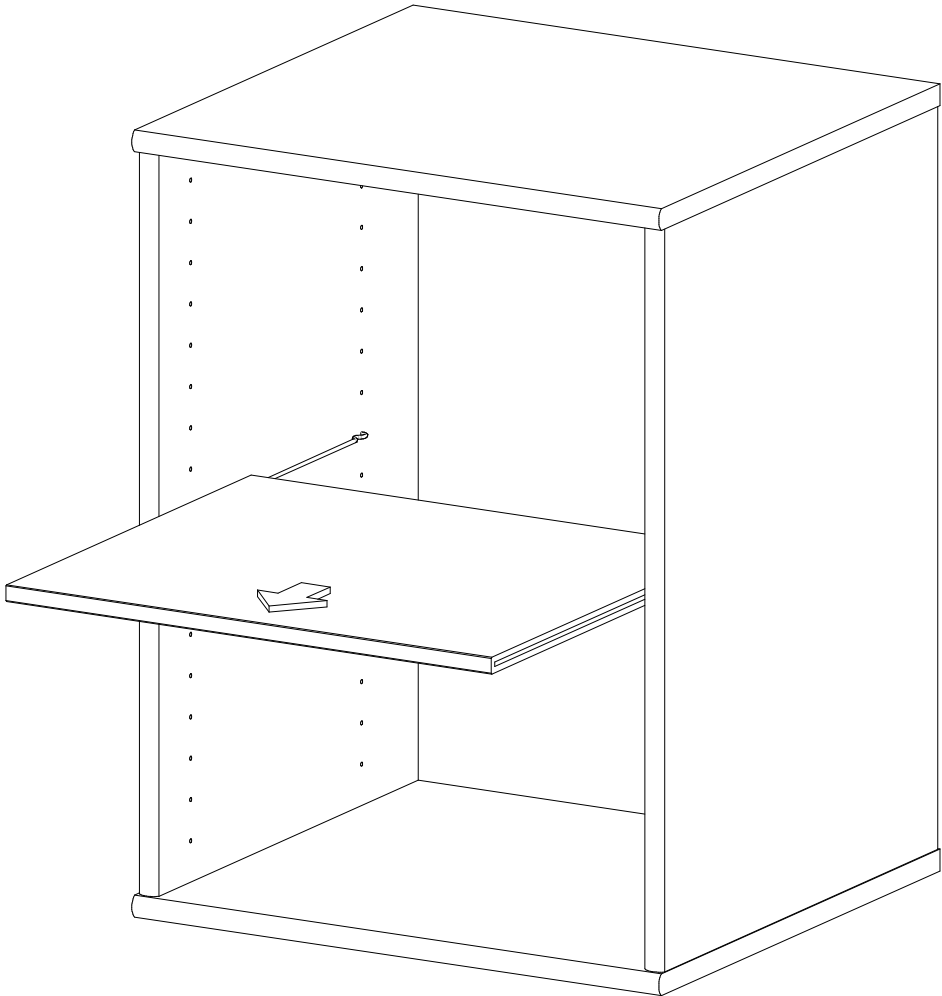

4

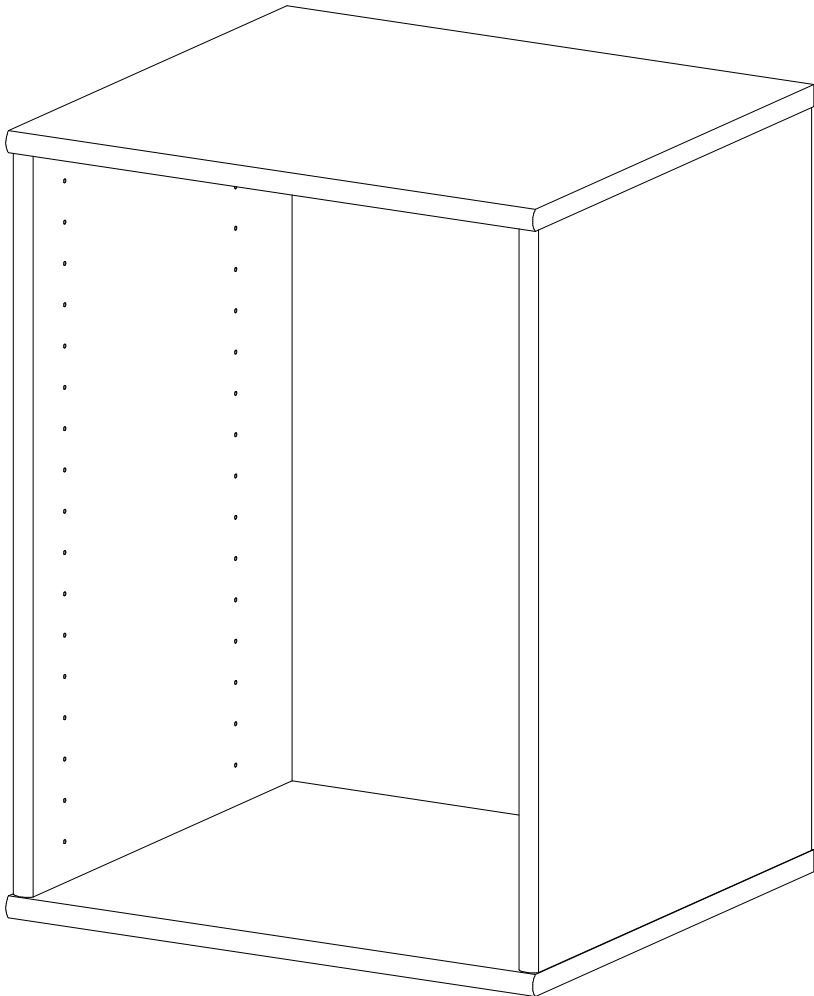

A

How to lock and unlock a drawer and -  
how to adjust a drawers vertical position.

Sådan låses og oplåses en skuffe og -  
sådan justeres skuffens lodrette position.

So wird die Schublade montiert bzw. abmontiert,  
und so wird die Position der Schublade senkrecht  
eingestellt.

Comment on peut fermer et démonter un tiroir et  
comment on peut ajuster la position verticale du tiroir.

Turn right or left to adjust drawer position.  
Drej til højre eller venstre for justering af skuffeposition.  
Bitte rechts oder links drehen, um die Position der  
Schublade einzustellen.

Tourner à droit ou gauche pour ajuster  
la position du tiroir.

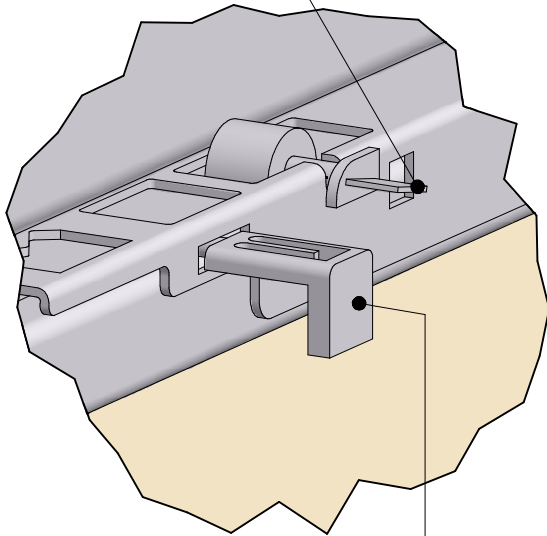

Push to lock. Pull to unlock.

Pres for at låse. Træk for at oplåse.

Schließen: Drücken Sie. Aufschließen: Ziehen Sie.  
Pressez pour fermer. Tirez pour démonter

5

31004-E9-P4/4

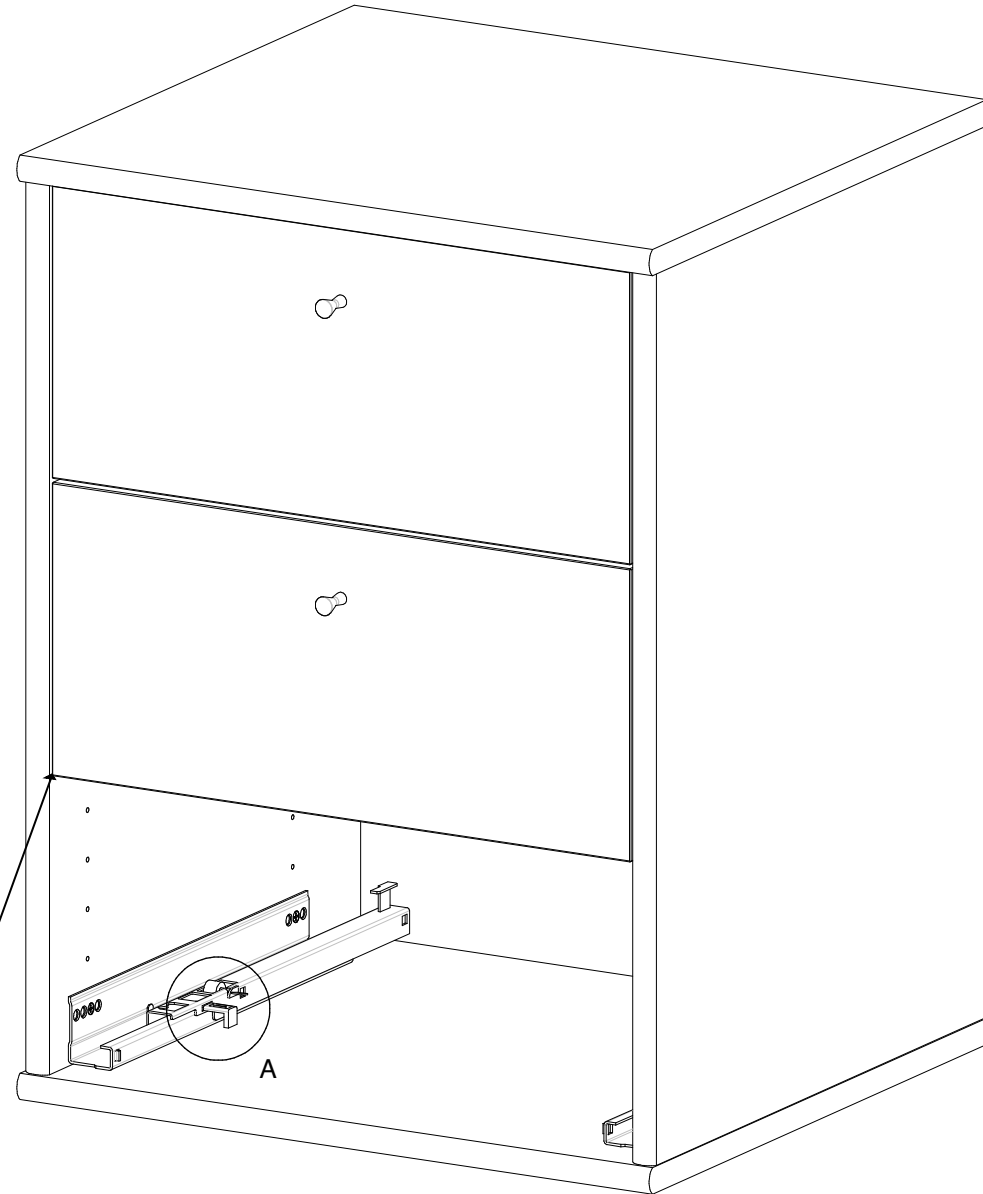

(Please observe the drawer is internal).  
(Observer venligst, at skuffen sidder indvendigt).  
(Bitte beachten Sie, dass die Schublade inwendig montiert werden muss)  
(Merci de remarquer, que le tiroir est monté à l'intérieur)



# MISTRAL

- design for your life

## M31

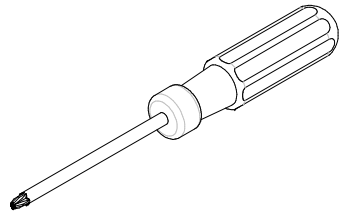
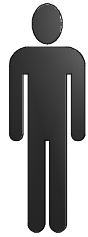

PZ2

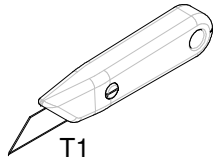

T1

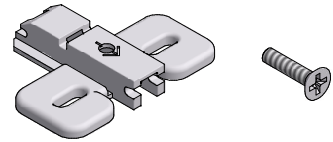

F1 x 2  
(6005160)

F2 x 4  
(6700503)

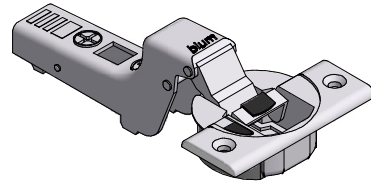

F3 x 1  
(6005110)

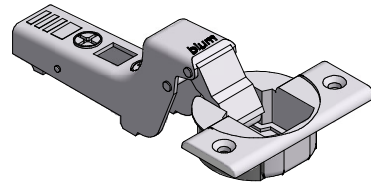

F4 x 1  
(6005120)



F5 x 4  
(6603215)



F6 x 1  
(4005361)

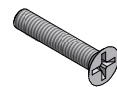

F7 x 1  
(6704422)



F8 x 1  
(6200210)



F9 x 2  
(3012233 L)

F9 x 2  
(3012232 R)

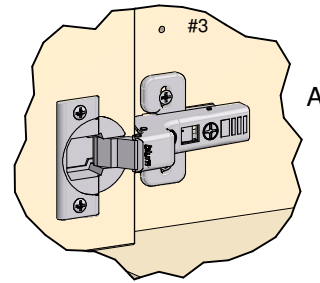

A

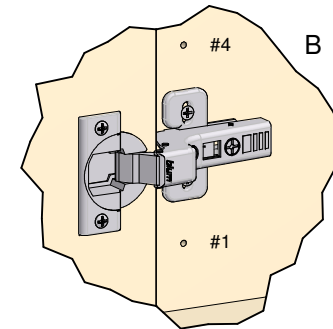

B

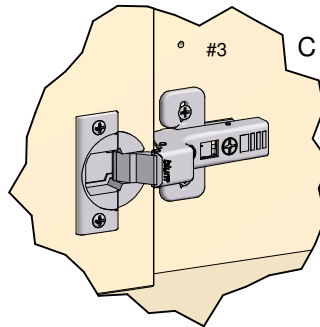

C

#059, #120, #126, #127, #128

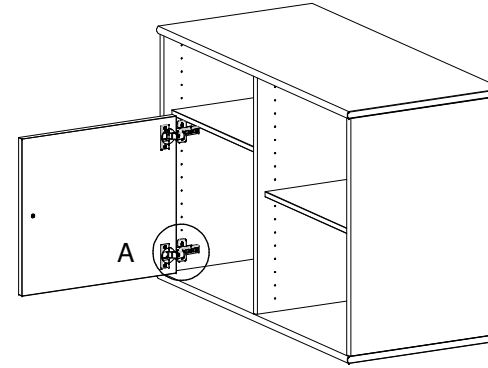

A

#060, #066, #067, #068

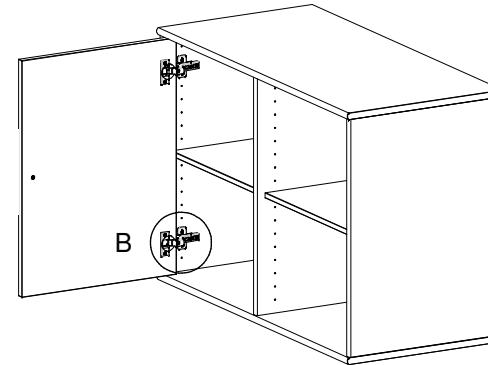

B

#062, #063, #064, #260

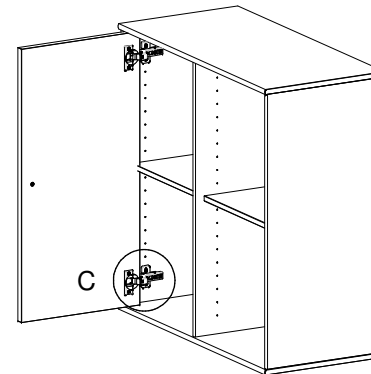

C

31028-E4-P1 /4

#138, #139

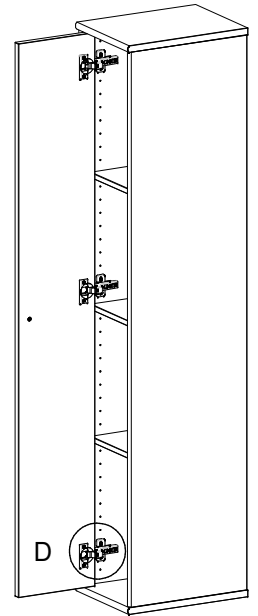

D

D

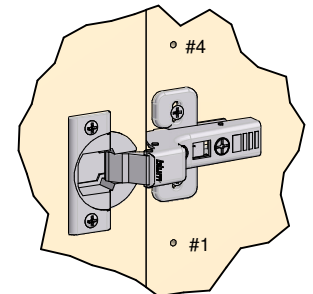

#4

#1

1

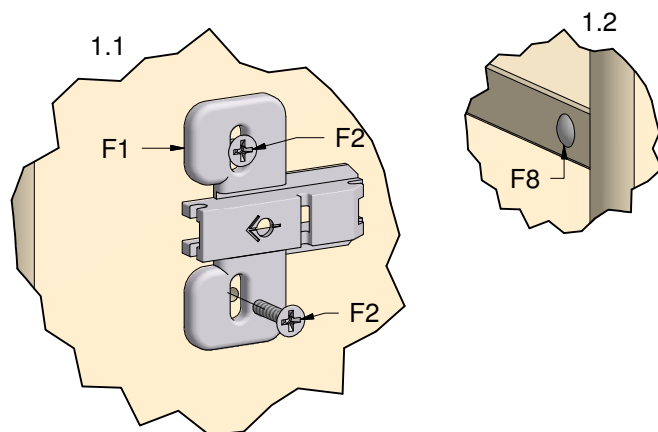
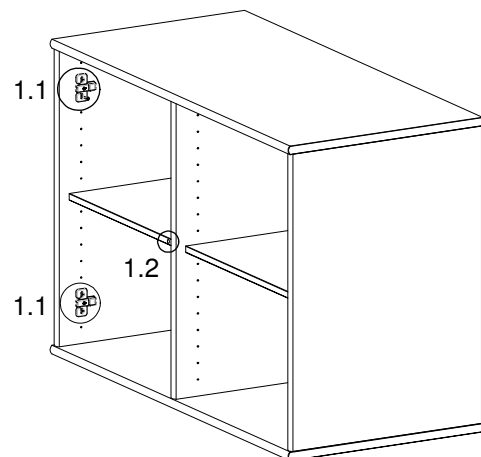

2

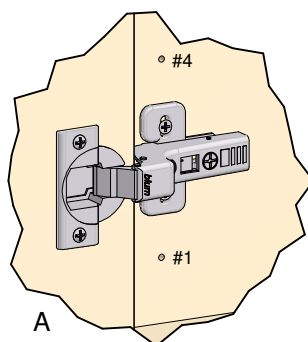
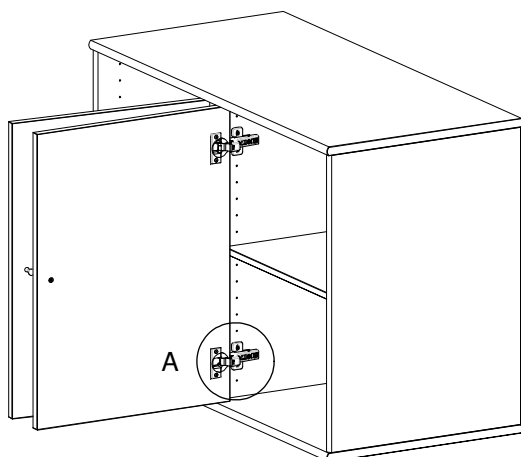
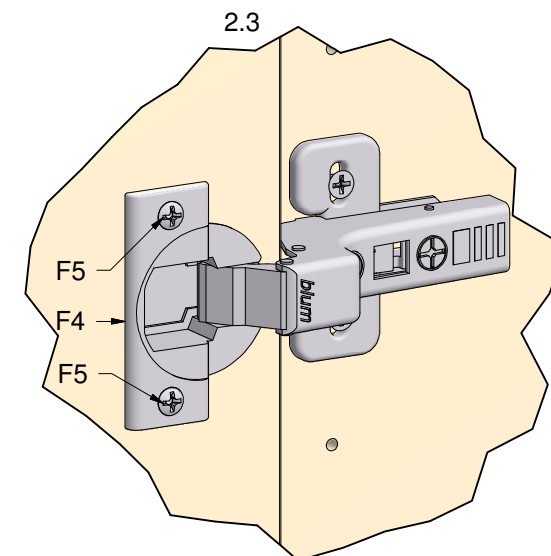
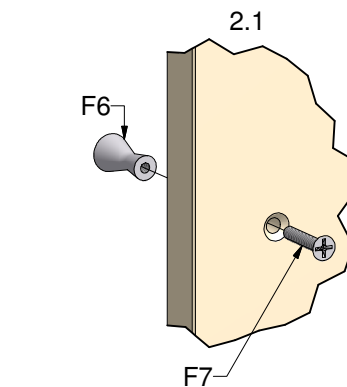
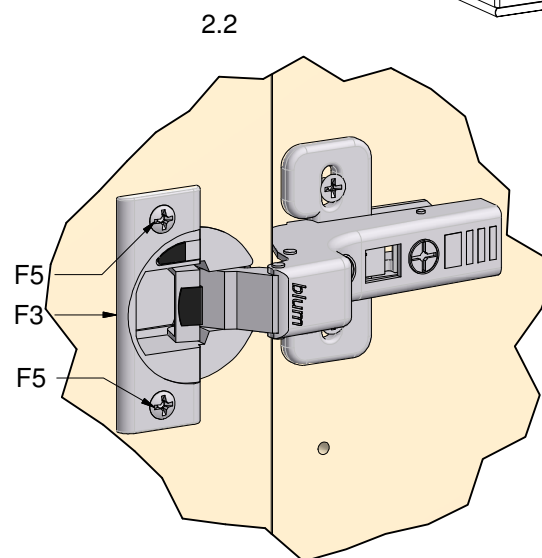
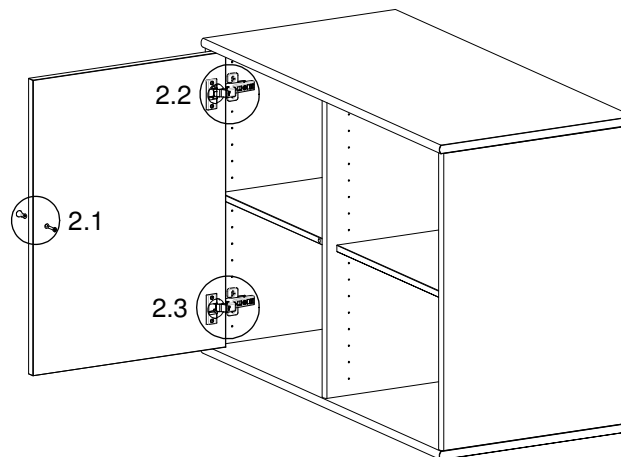

Ved montering af begge døre overfor hinanden i skillerum:  
Venligst rekvirer andre fittings nr. F2 på:  
[sales@hammel-furniture.dk](mailto:sales@hammel-furniture.dk)

By mounting of both doors opposite each other as shown on the illustration:  
Please request other fittings No. F2 at:  
[sales@hammel-furniture.dk](mailto:sales@hammel-furniture.dk)

Bei Montage beider Türen neben einander an die Trennwand: Bitte beziehen Sie Sonder-F2 Fittings durch:  
[sales@hammel-furniture.dk](mailto:sales@hammel-furniture.dk)

Si voulez monter deux portes dans la même partition comme au dessin:  
Merci de commander ferrure No. F2 à:  
[sales@hammel-furniture.dk](mailto:sales@hammel-furniture.dk)

Genom att montera båda dörrarna mitt emot varandra i kabinen vänligst begära andre fittings F2 från:  
[sales@hammel-furniture.dk](mailto:sales@hammel-furniture.dk)

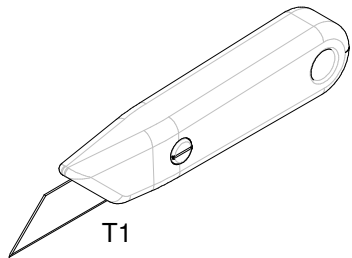
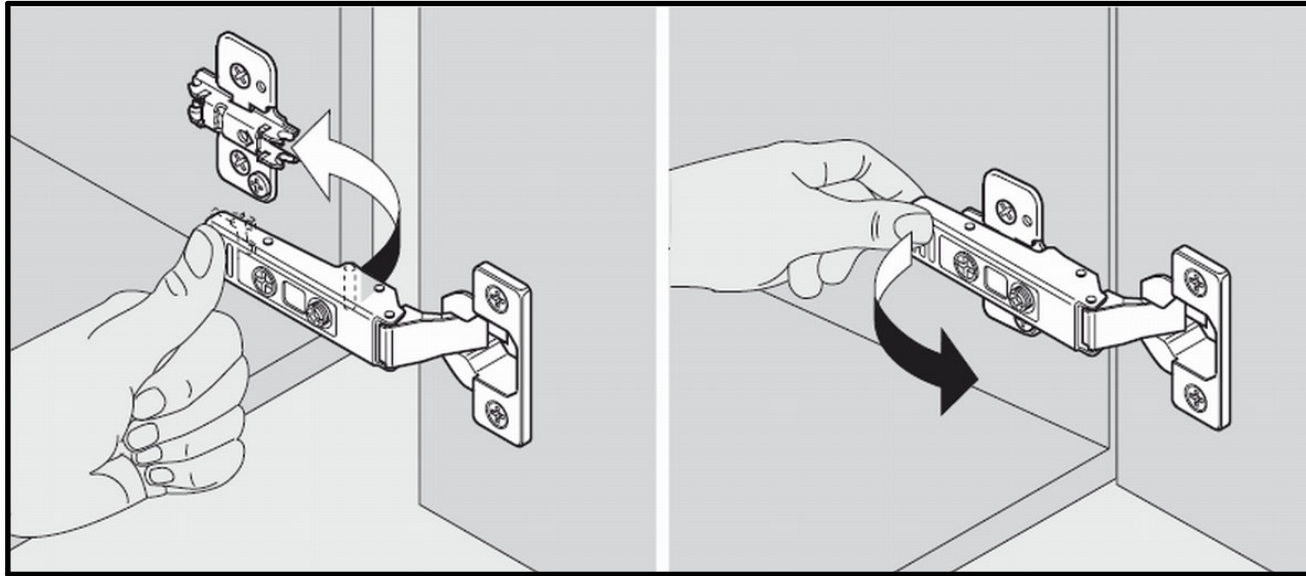

T1

Bruges kun ved stofdøre.  
Only for fabric doors.  
Nur für Tür mit Stoff.  
Seulement pour portes en tissu.  
Endast till tygdörrar.

Skær forsigtigt et lille hul, så skruen kan komme igennem stoffet.  
Carefully cut a small hole to allow the screw to pass through the fabric.  
Seien Sie vorsichtig und schneiden Sie ein sehr kleines Loch, um die Schrauben zu.  
Couper avec précaution un petit trou pour que la vis peut traverser le tissu.  
Rispa, skär försiktigt ett litet hål, så att skruven kan tränga igenom tyget.

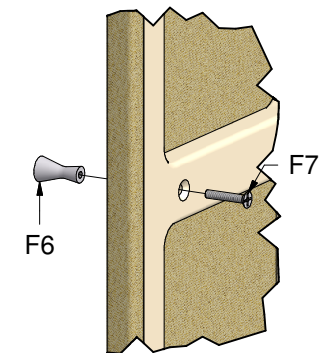
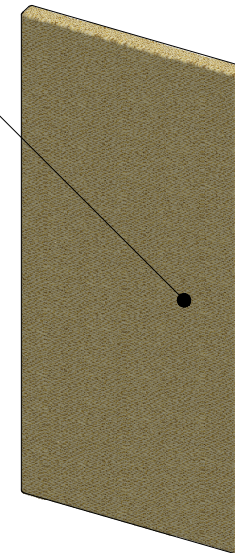

F6

F7

1

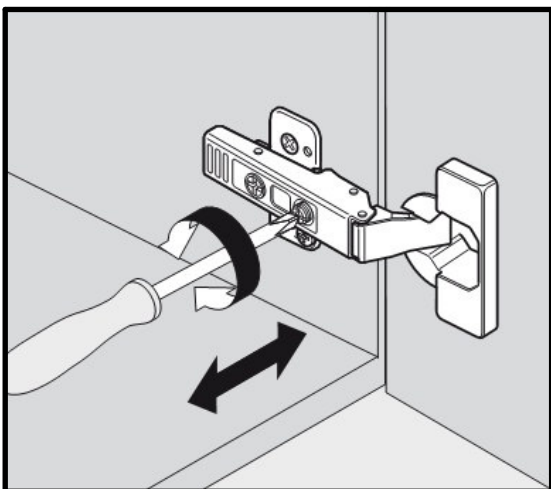

2

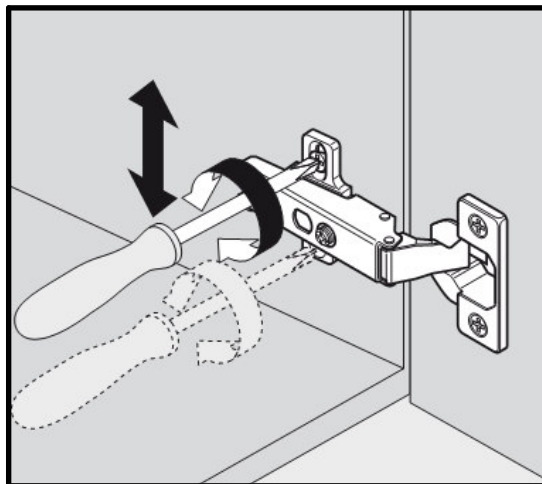

3

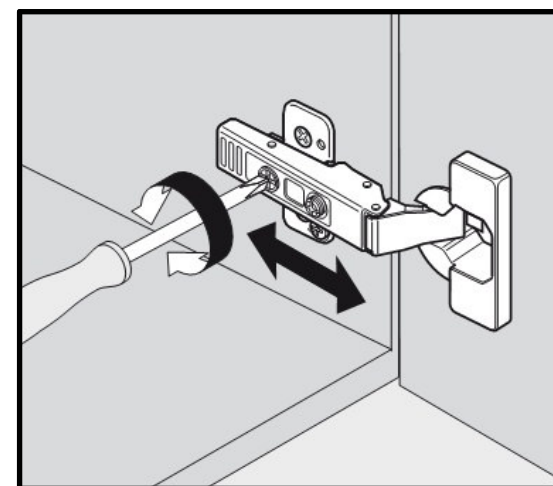

4

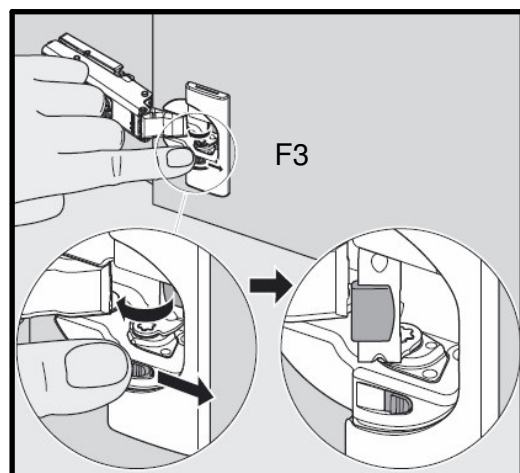

5

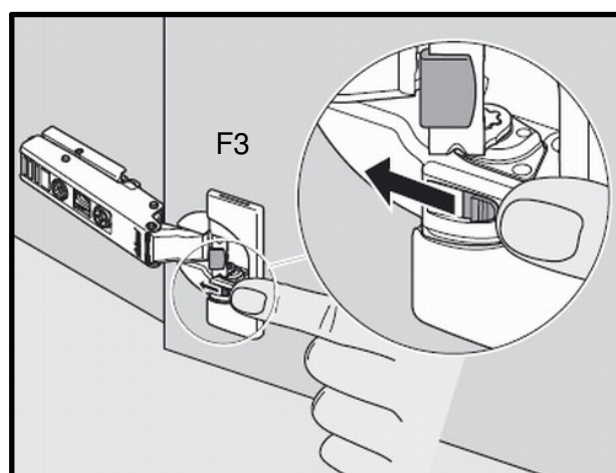

6

L=venstre/left/links/gauche/vänstre  
R= højre/right/rechts/droit/höger

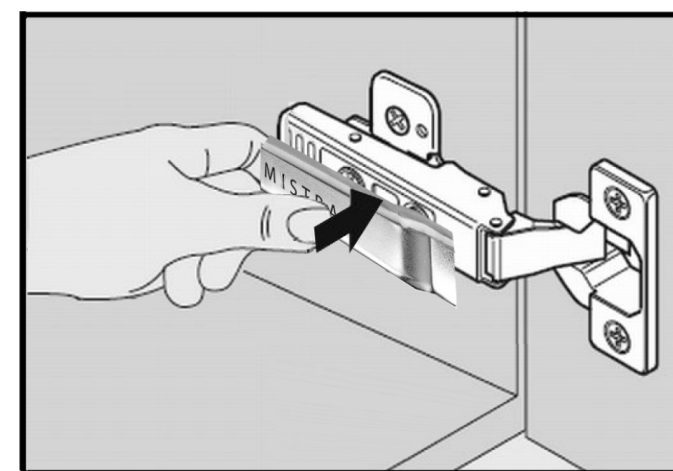

(F9).  
Anvend kun 2xL\* eller 2xR\* pr. dør.  
Only use 2xL\* or 2xR\* covers f/1 door.  
Nur 2xL\* oder 2xR\* per Tür anwenden.  
Utilisez seulement 2xL\* ou 2xR\* par porte.  
Använd endast 2xL\* eller 2xR\* lock/dörr.