

RAVENNA 22

Option L

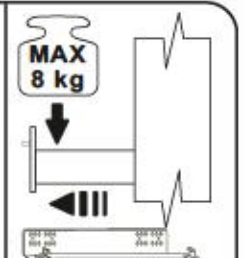

Option R

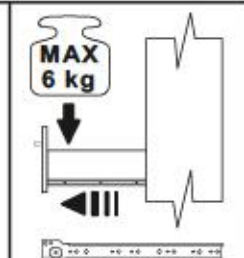
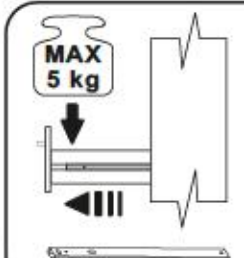
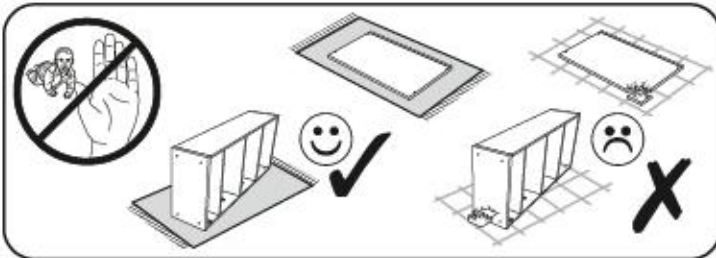
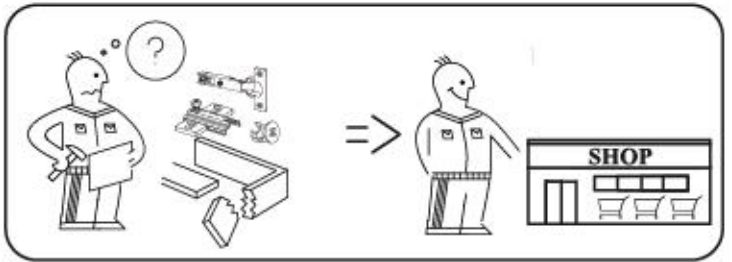
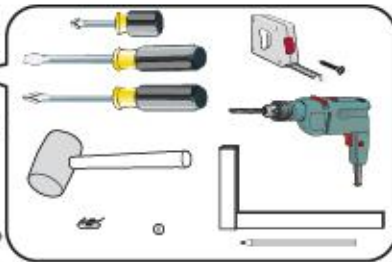
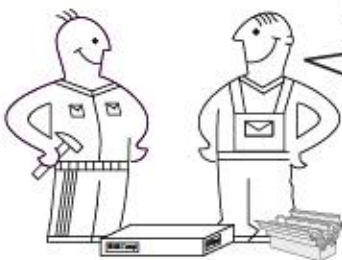
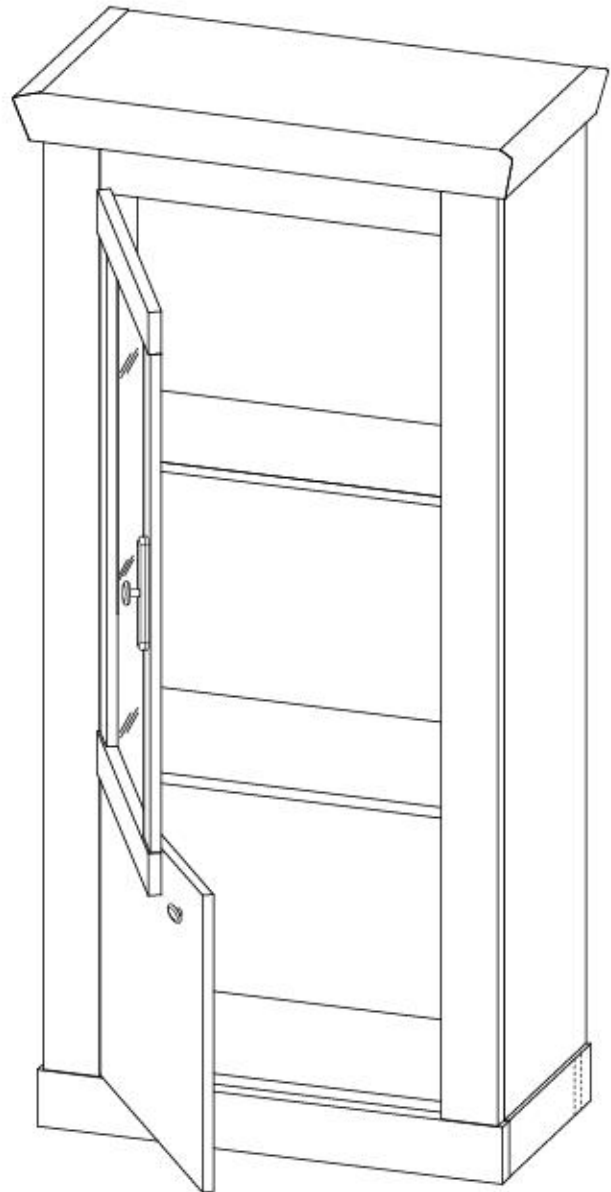

RAVENNA 22

Option L



Option R



max.



HC 57

max.



HC 62

HC 65

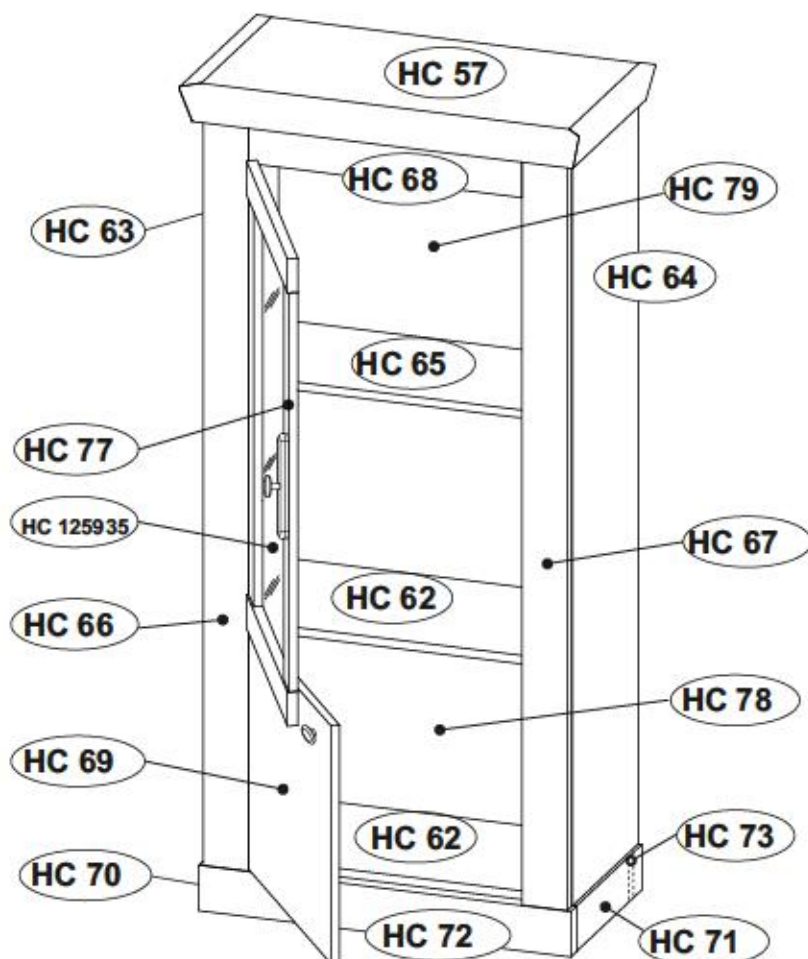

HC 57	x1	702	372	65	1/1
HC 62	x2	611	299	15	1/1
HC 63	x1	1361	320	15	1/1
HC 64	x1	1361	320	15	1/1
HC 65	x1	610	273	22	1/1
HC 66	x1	1361	80	22	1/1
HC 67	x1	1361	80	22	1/1
HC 68	x1	483	124	18	1/1
HC 69	x1	415	477	15	1/1

HC 70	x1	317	80	28	1/1
HC 71	x1	317	80	28	1/1
HC 72	x1	656	80	28	1/1
HC 73	x1	598	80	28	1/1
HC 77	x1	813	477	18	1/1
HC 78	x1	417	623	3	1/1
HC 79	x1	949	623	3	1/1
HC 125935	x1	723	386	4	1/1

RAVENNA 22

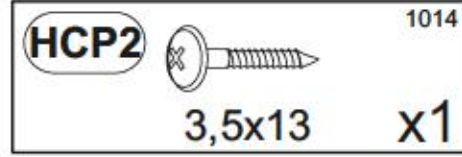
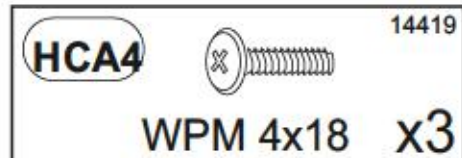
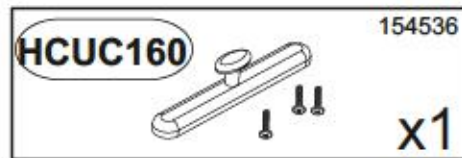
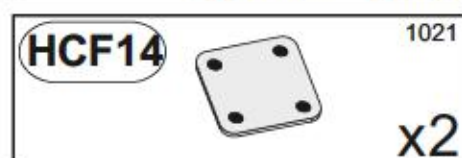
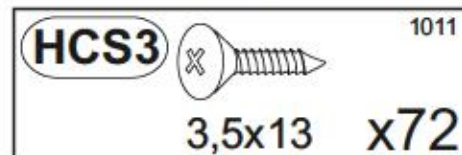
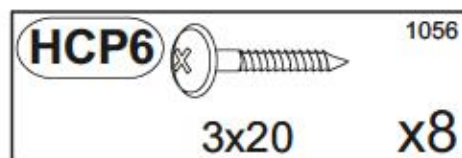
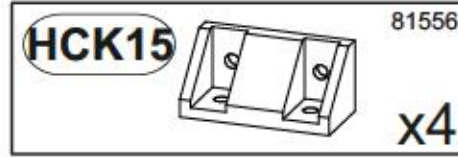
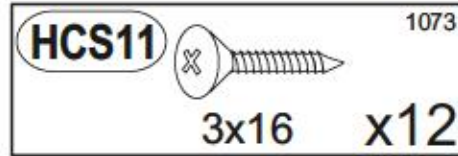
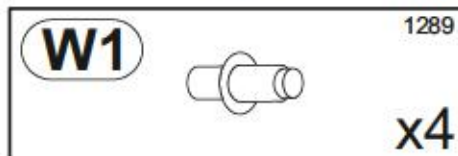
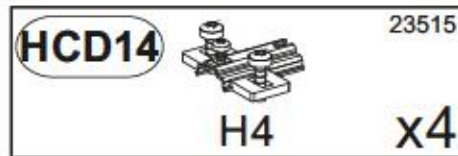
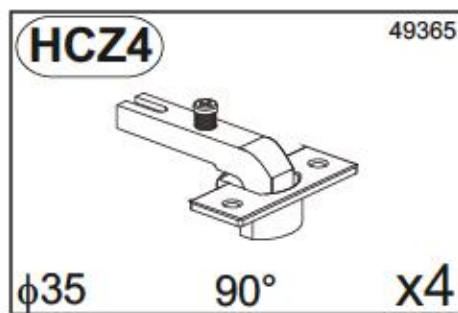
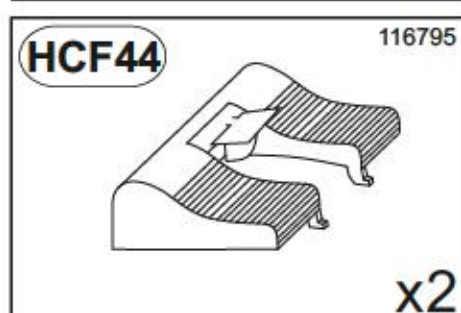
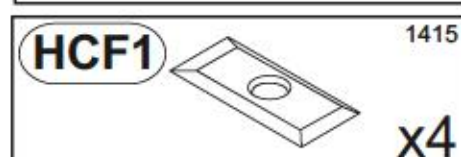
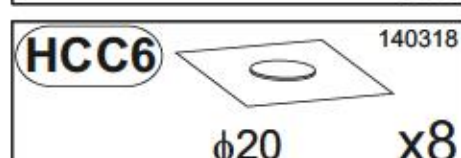
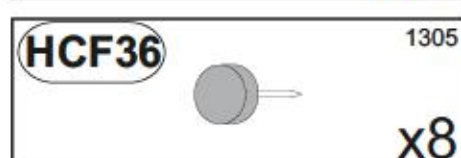
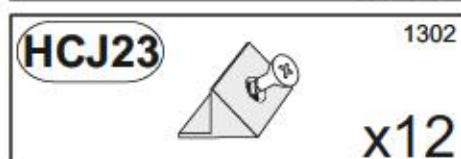
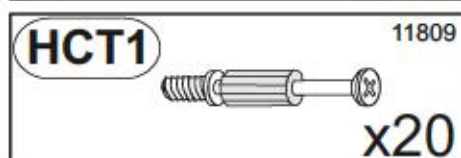
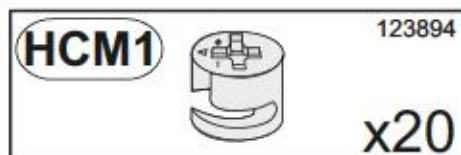
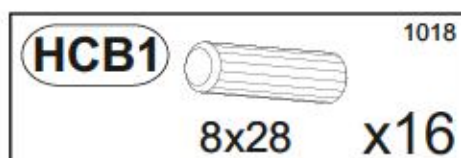

1

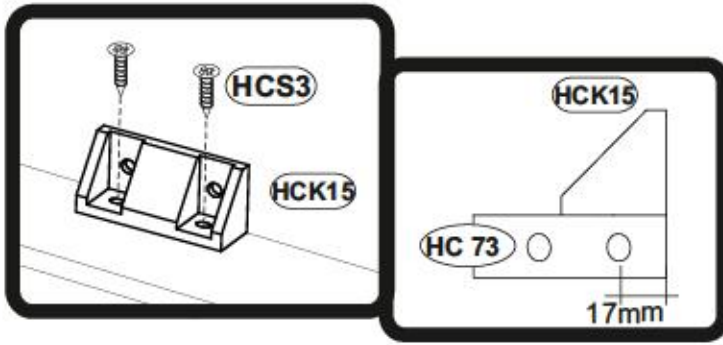

HCM1		12.38.94	x4
HCK15		815.98	x2
HCS3		10.11	3,5x13 x4

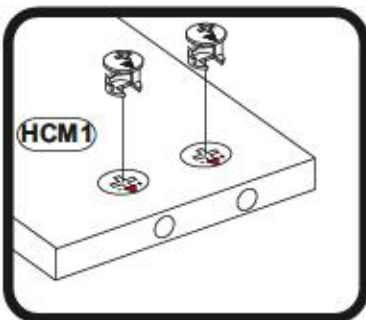
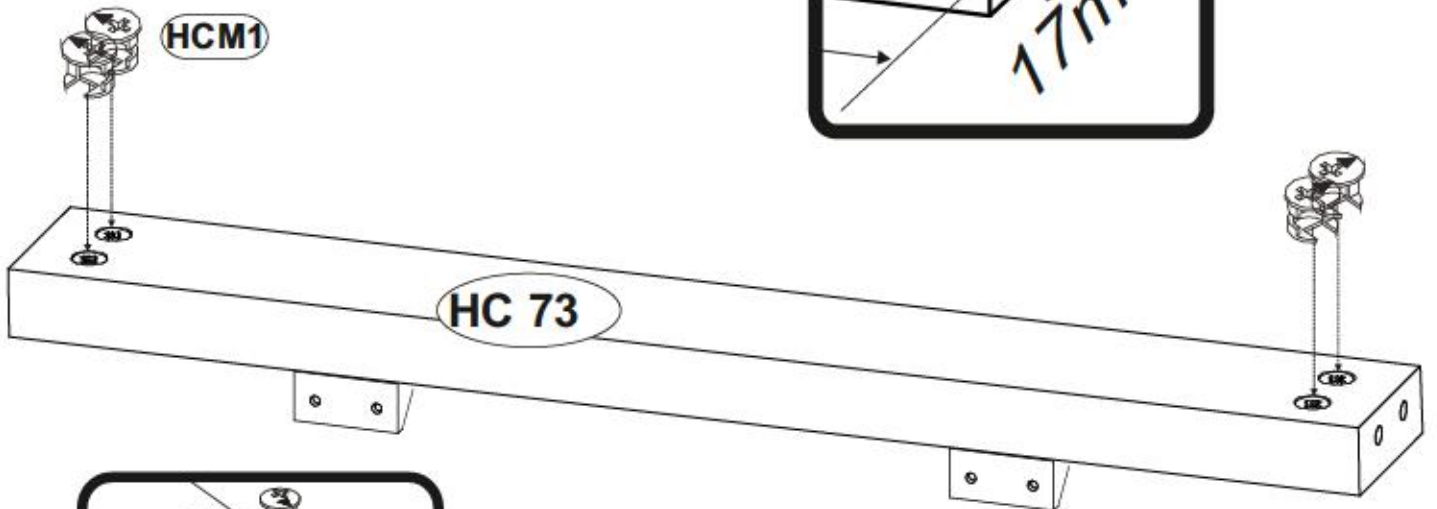
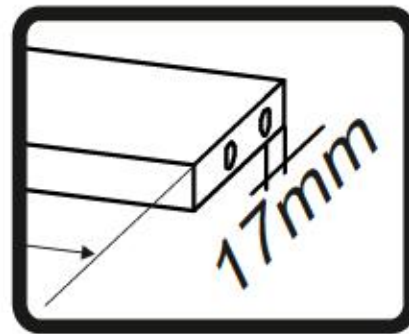
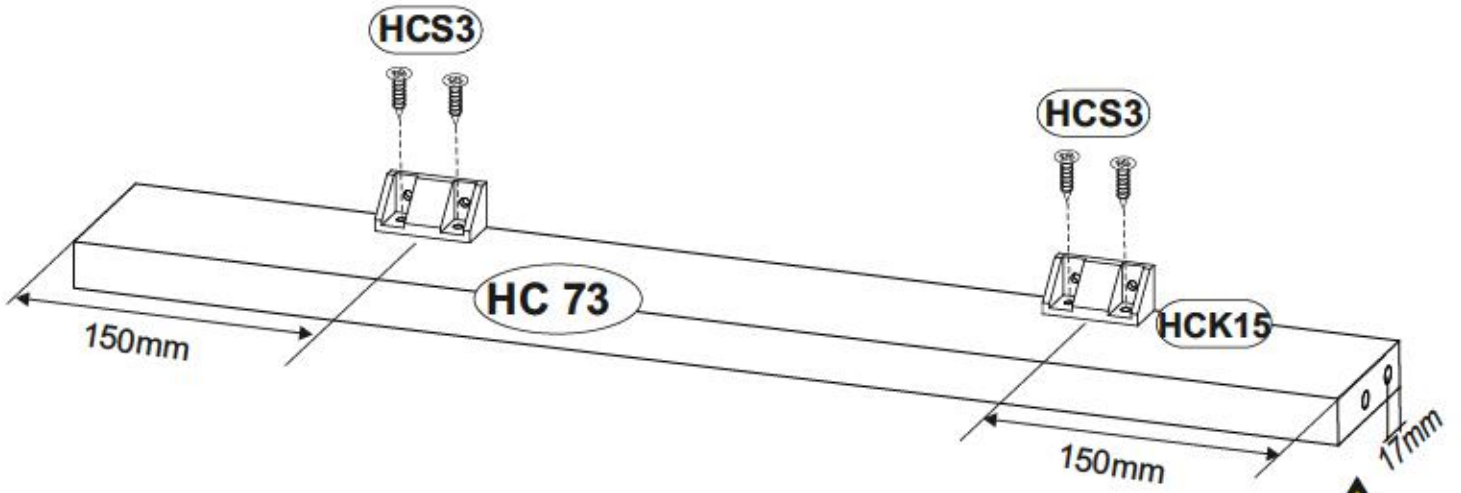

2

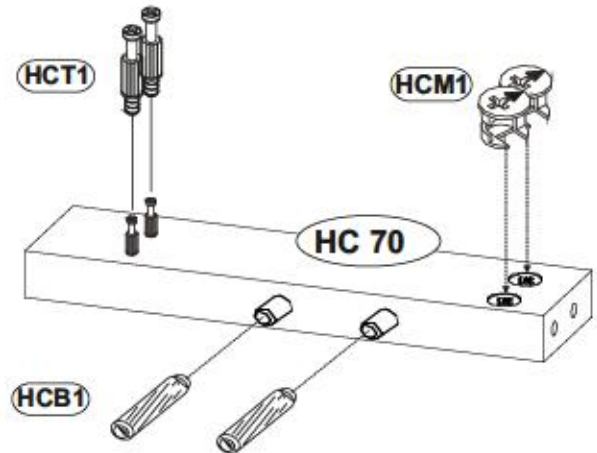
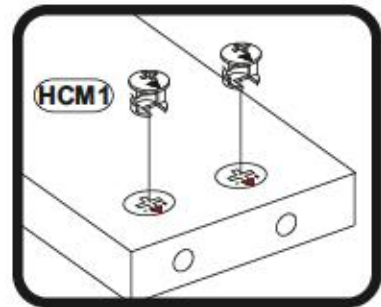
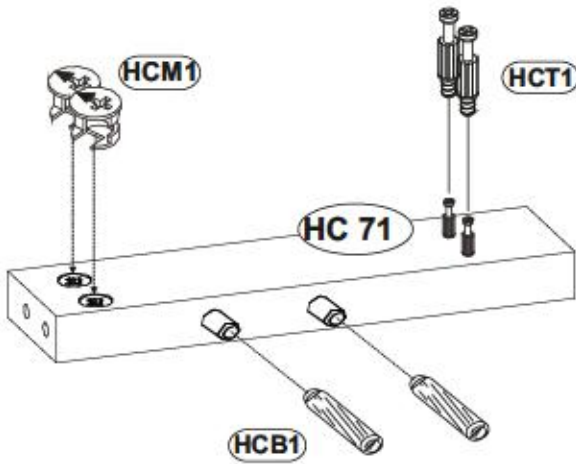
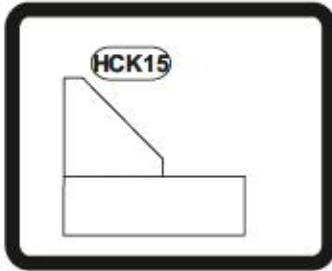
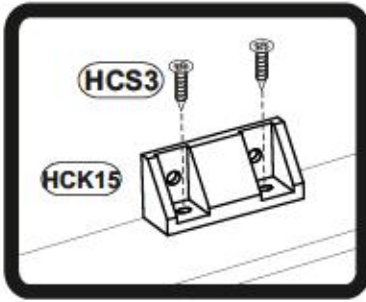
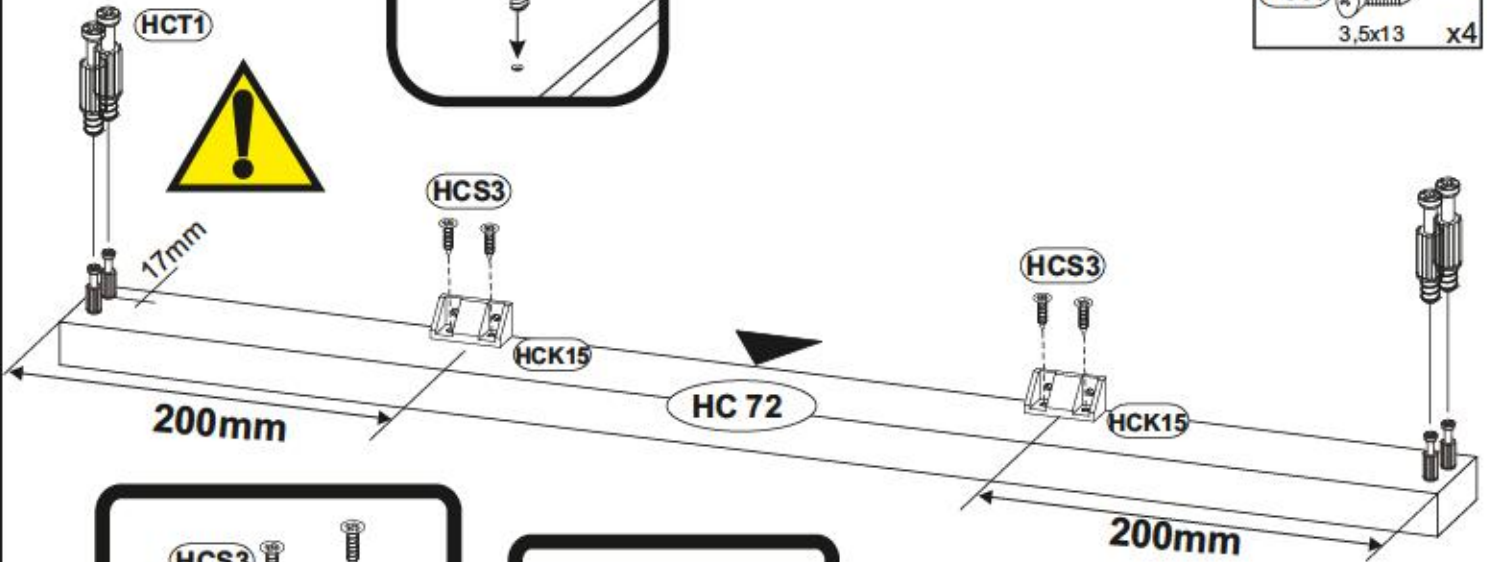

HCM1 129914 x4	HCT1 11809 x8
HCB1 1018 8x28 x4	HCK15 000100 x2
HCS3 1011 3,5x13 x4	

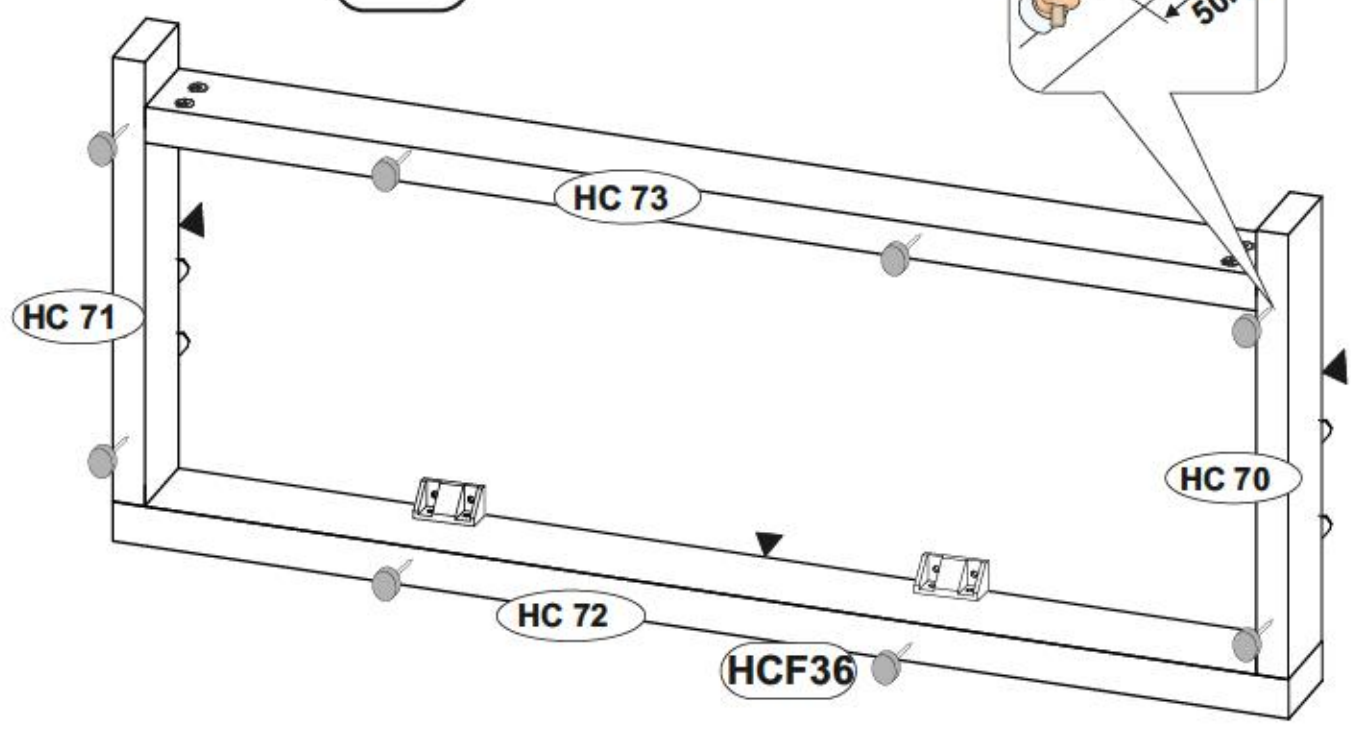
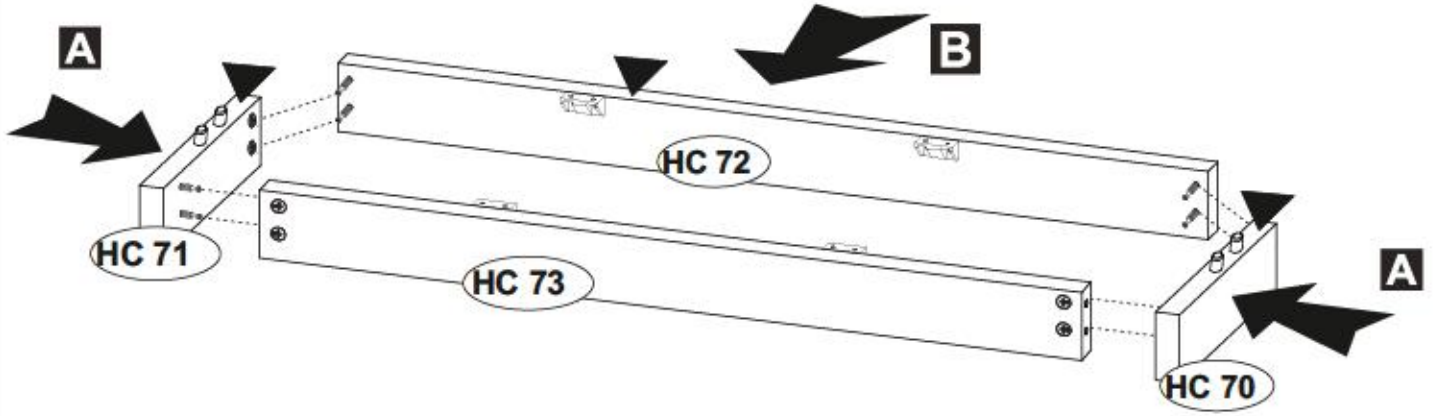
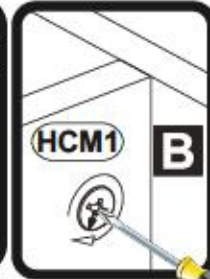
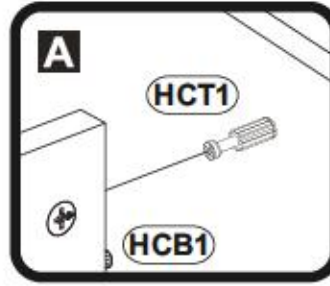

3

HCF36 1305
x8



HCB1		1018
	8x28	x4
HCM1		129804
		x4
HCT1		11809
		x8

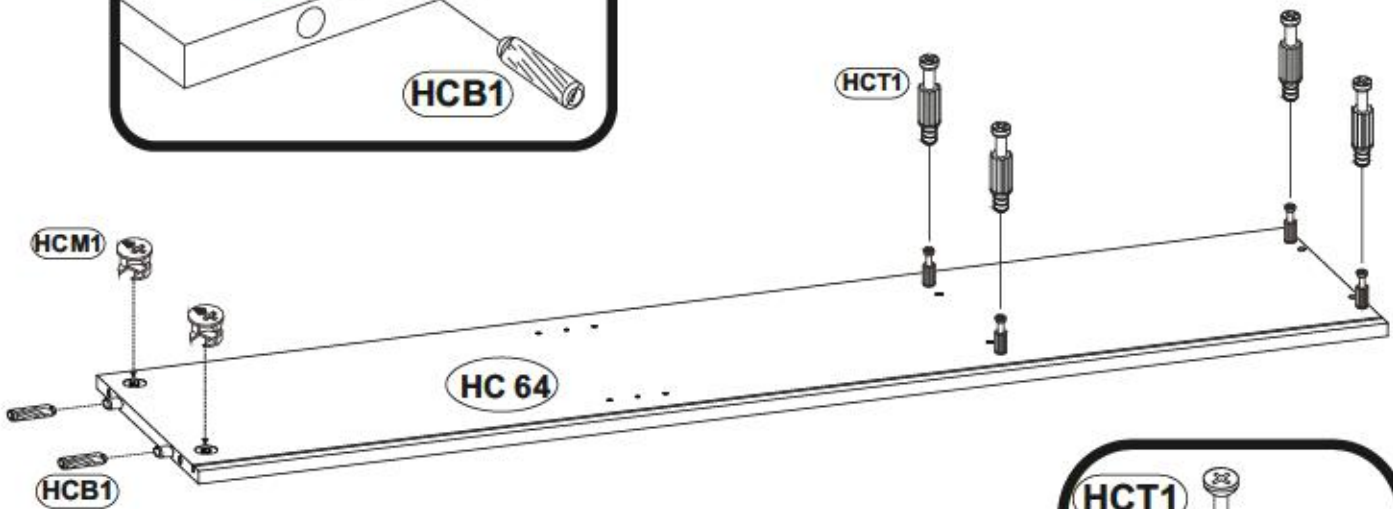
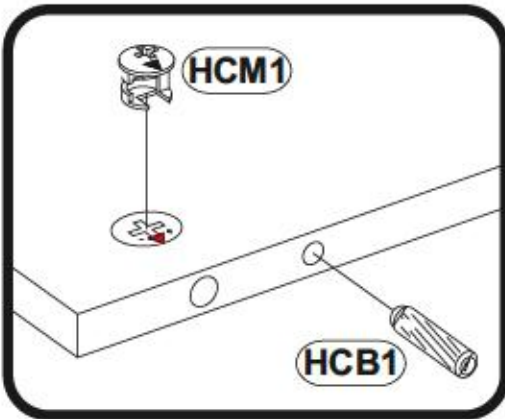
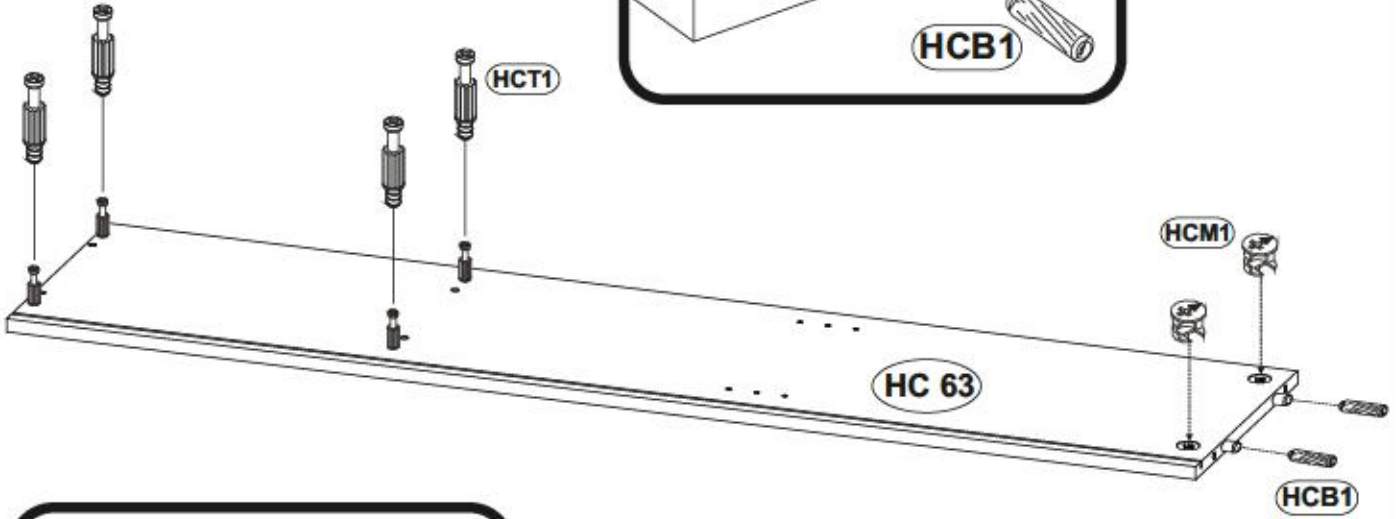
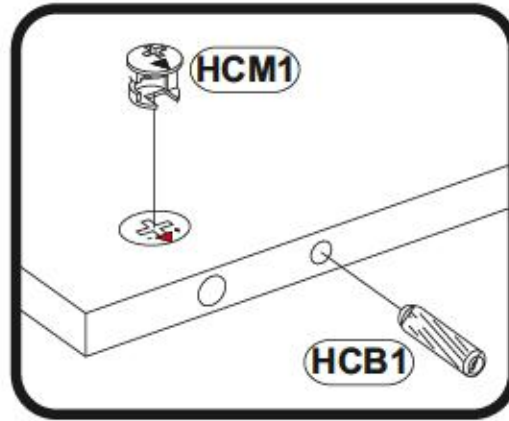

5

Option L

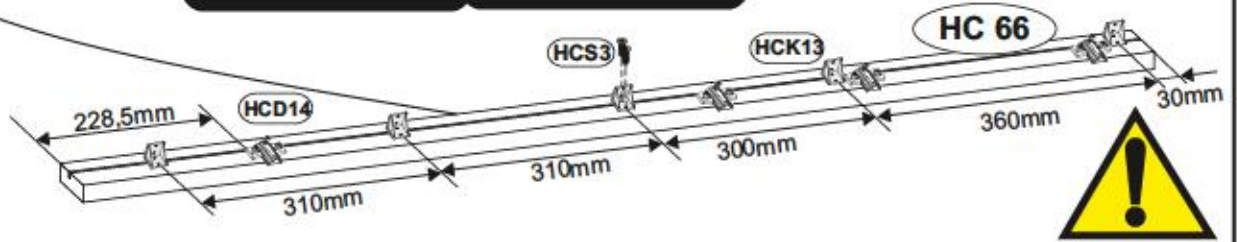
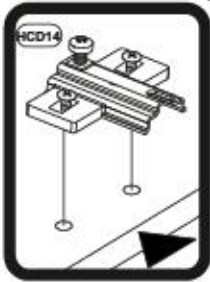
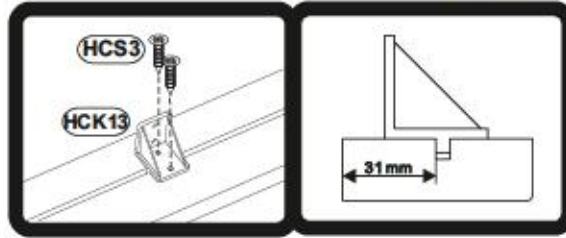
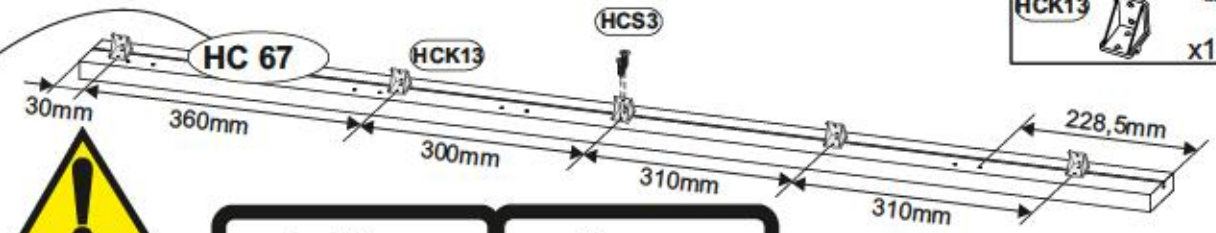
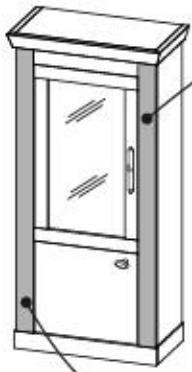

HCD14		23515
	H4	x4
HCS3		1011
	3,5x13	x20
HCK13		49776
		x10

**6**

Option R



HCD14		23515
	H4	x4
HCS3		1011
	3,5x13	x20
HCK13		49776
		x10

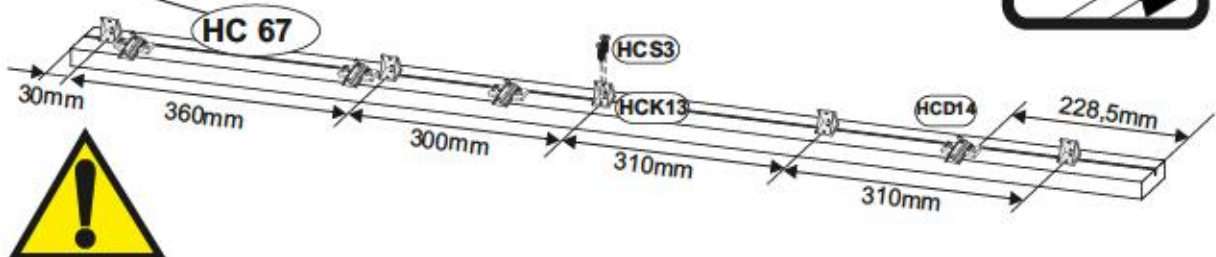
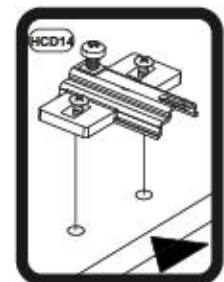
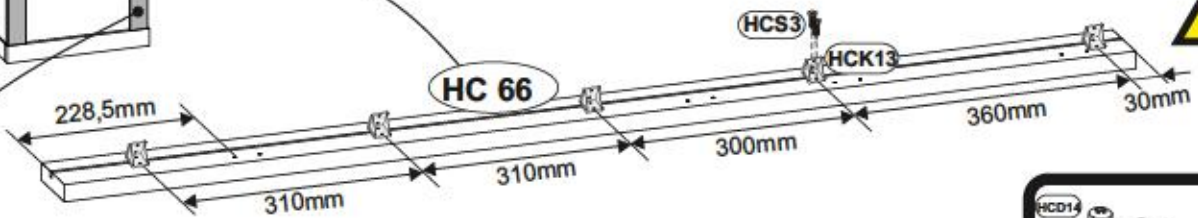
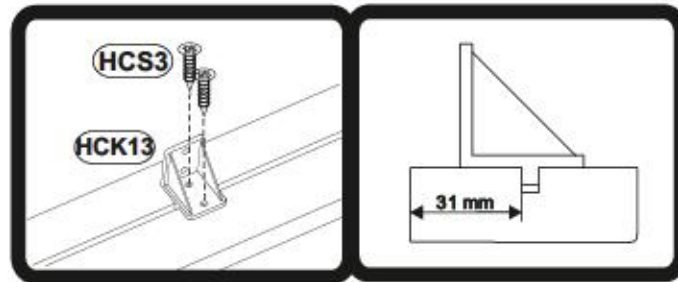
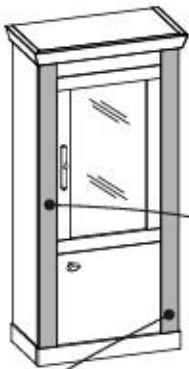

HCF14 1021 x2	HCB1 1018 8x28 x8
HCS3 1011 3,5x13 x4	HCM1 123894 x8
	HCT1 11809 x4

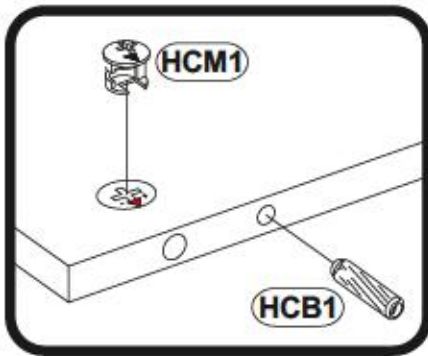
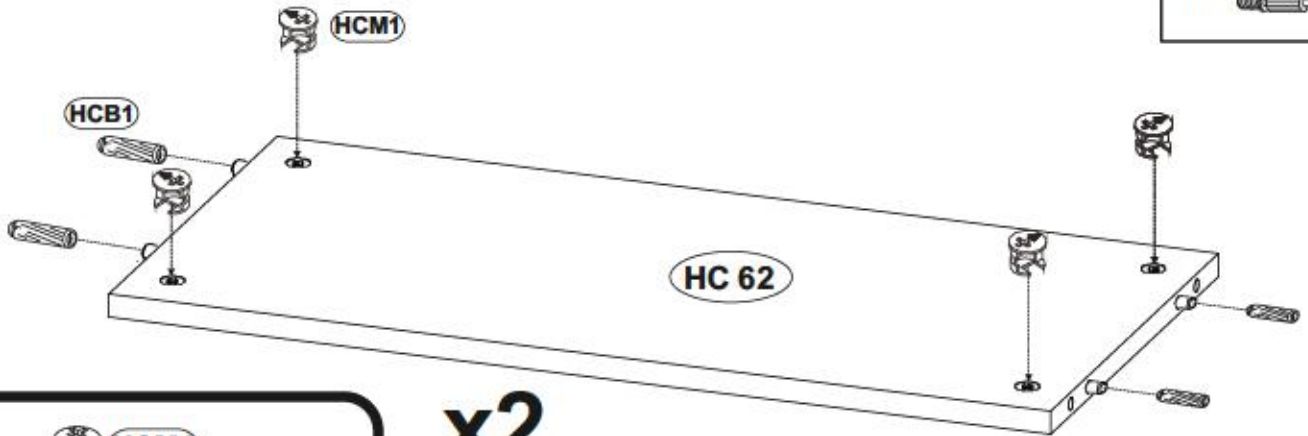

x2

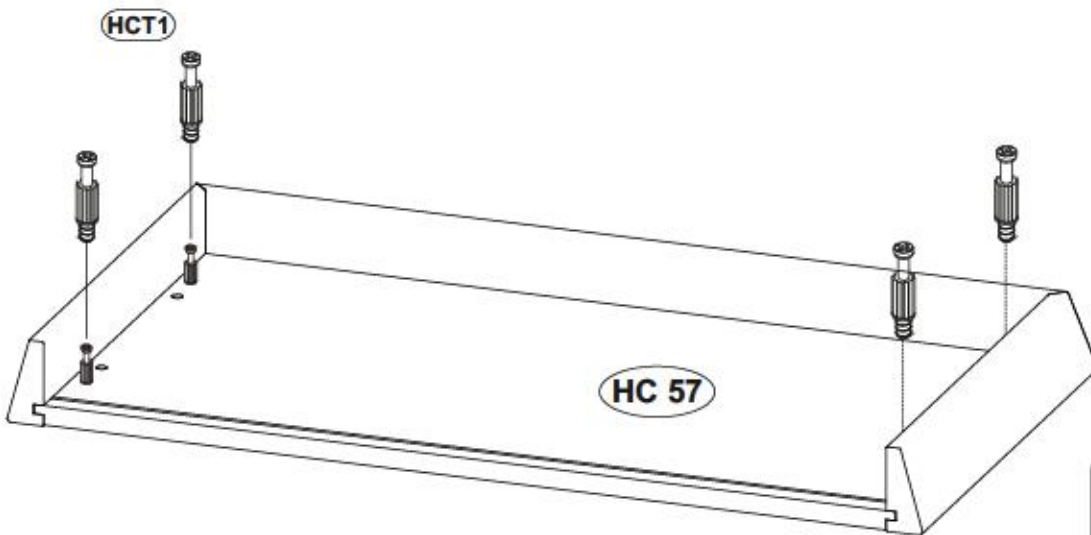
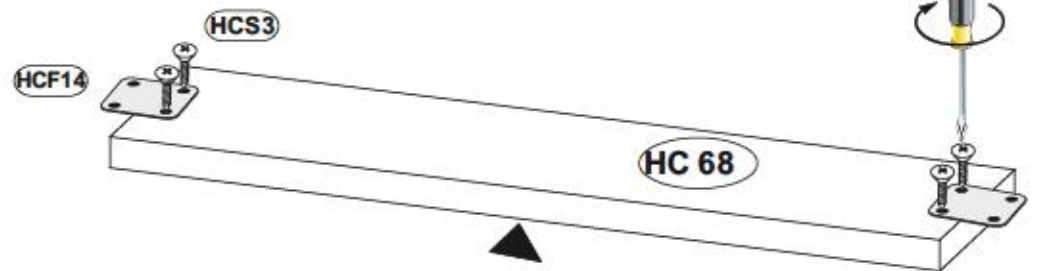
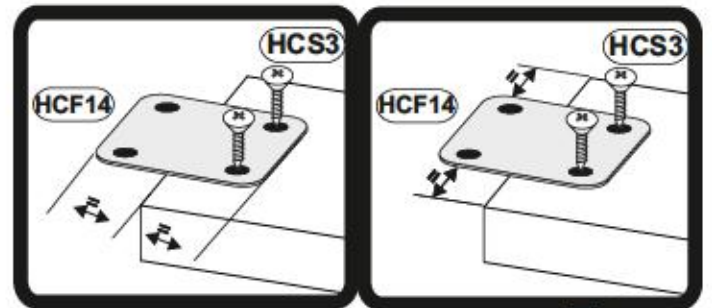

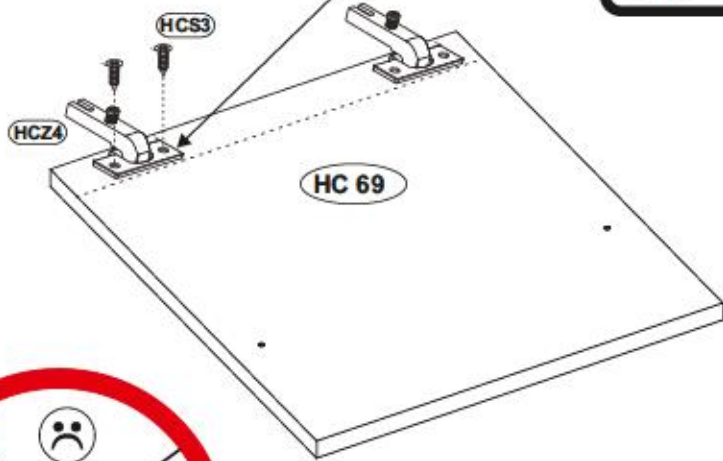
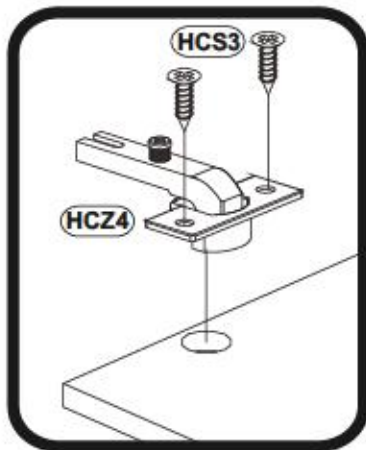
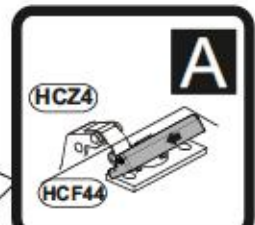
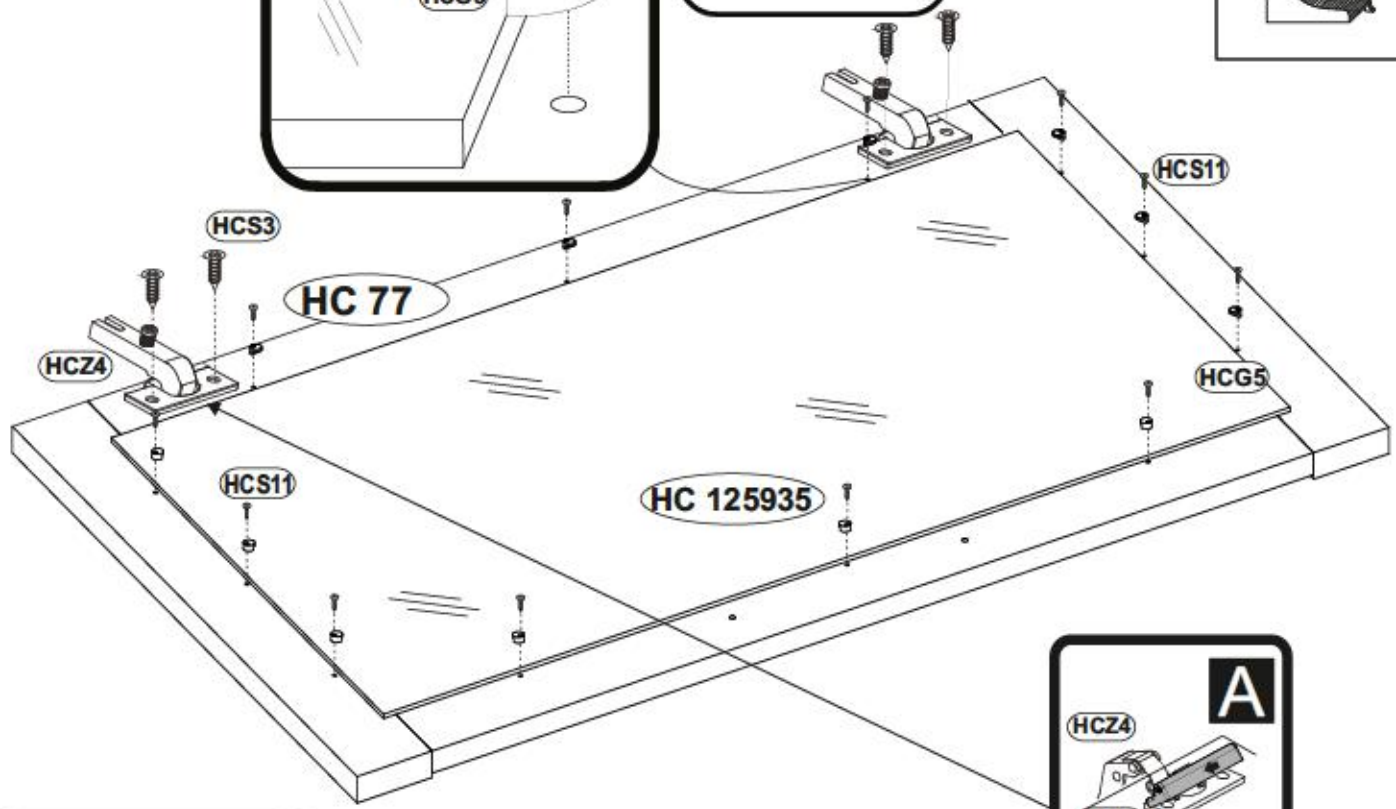
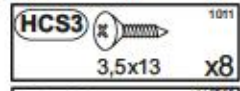
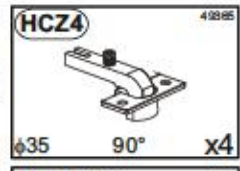
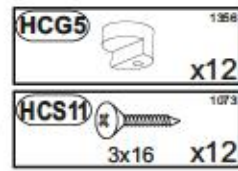
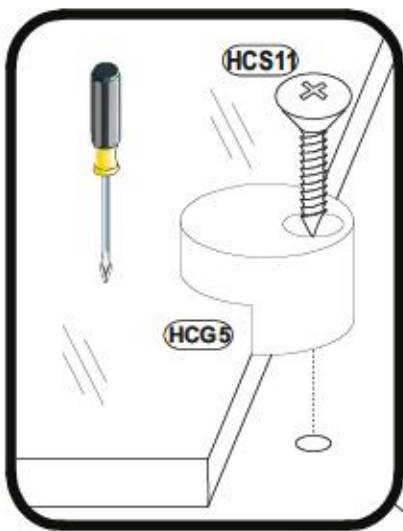

9

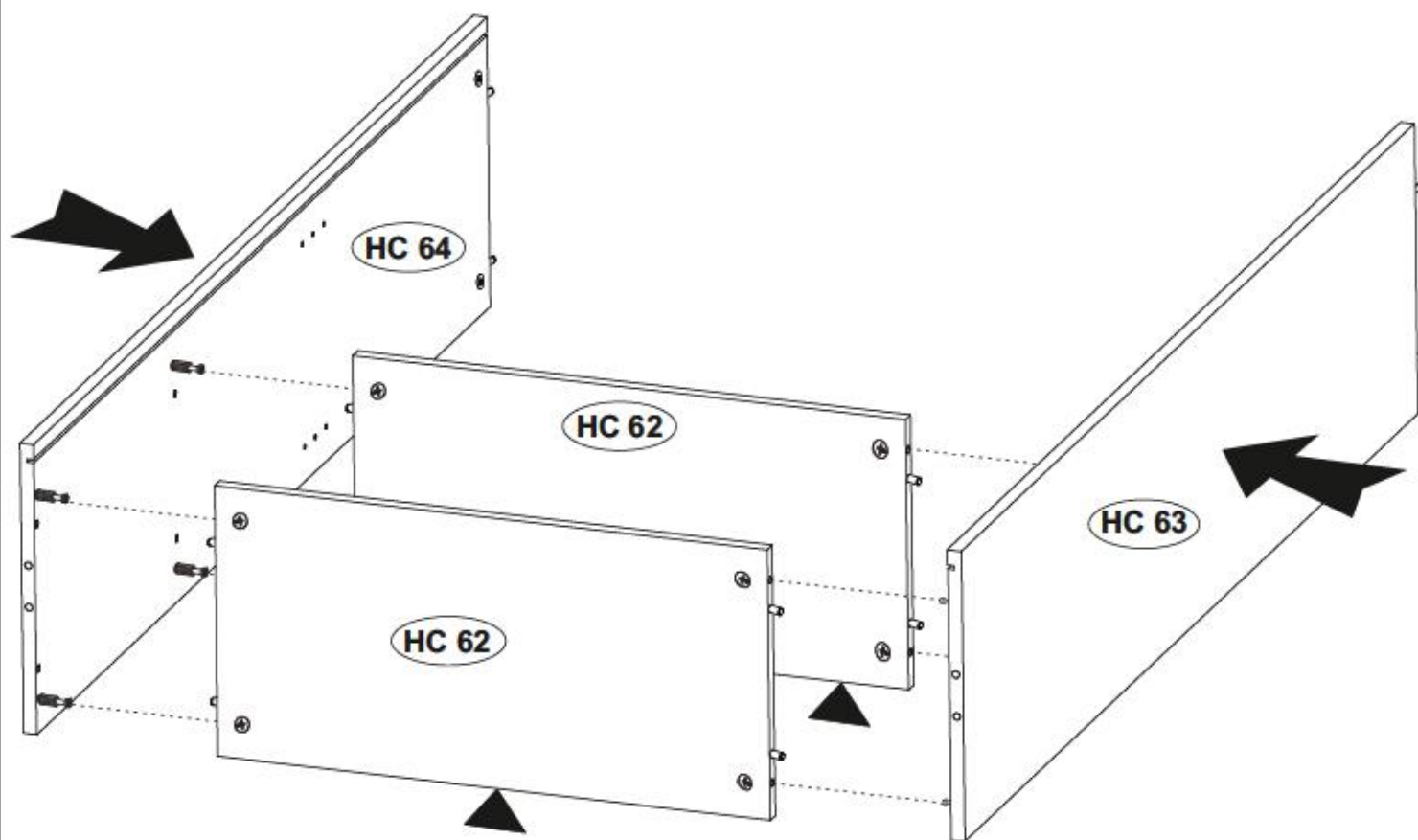
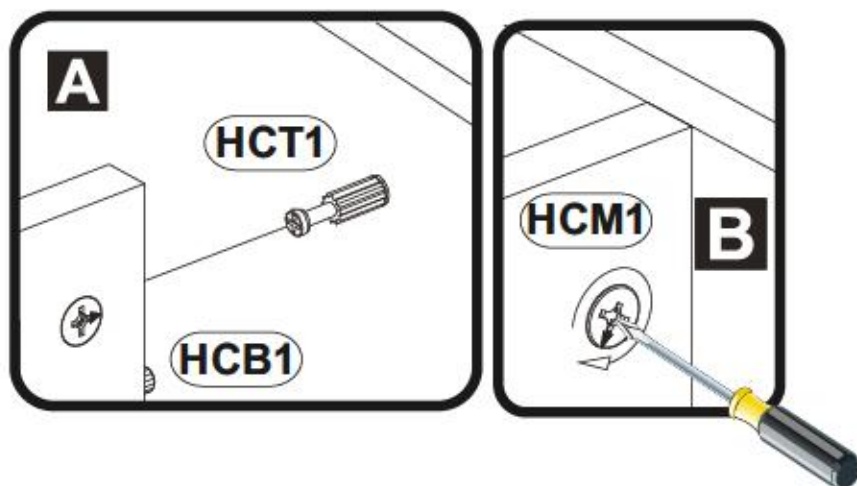

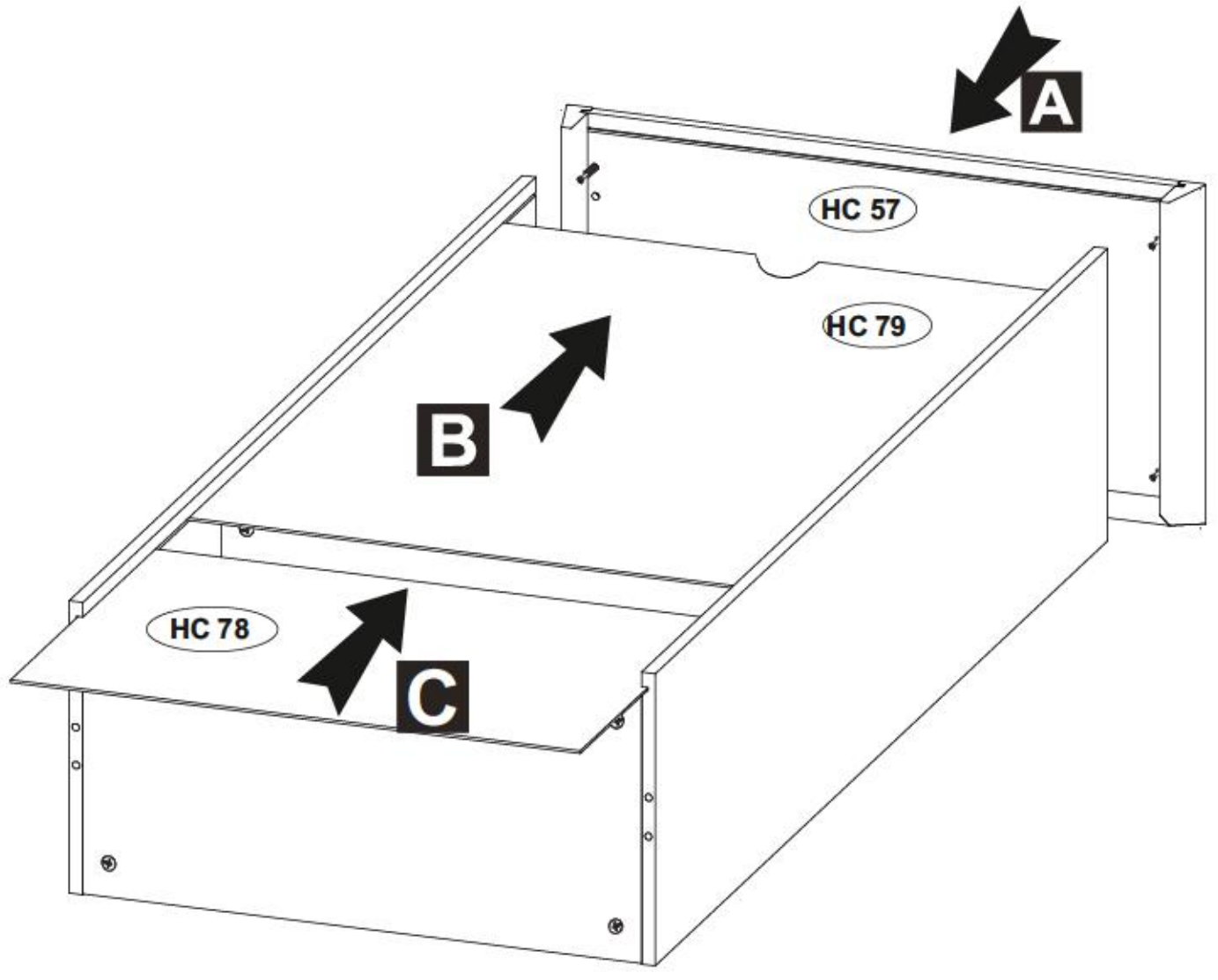
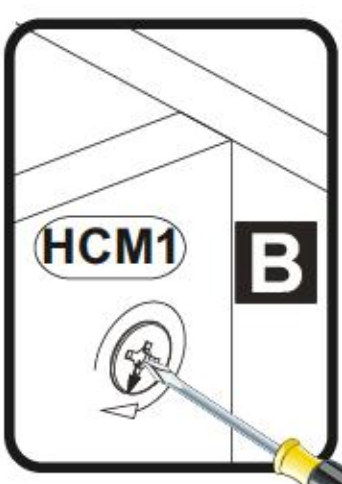
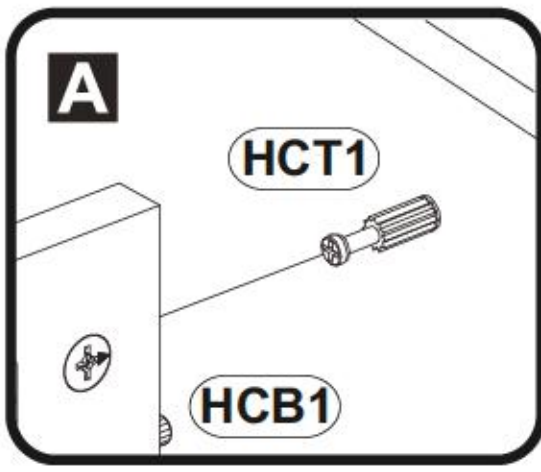

HCP6	1058
3x20	x8
HCJ23	1302
	x12
HCF1	1415
	x4
HCS3	1011
3,5x13	x8

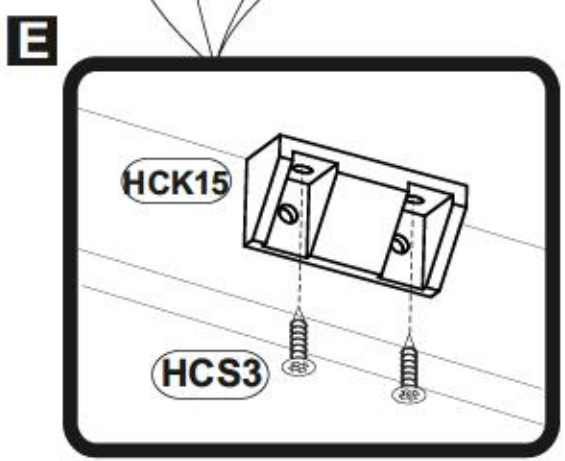
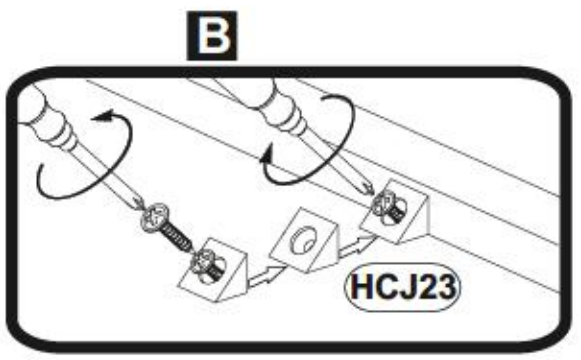
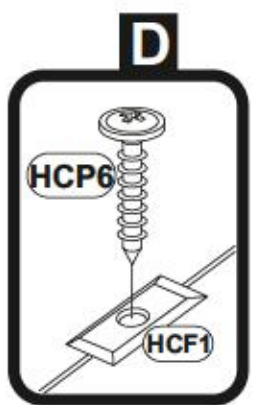
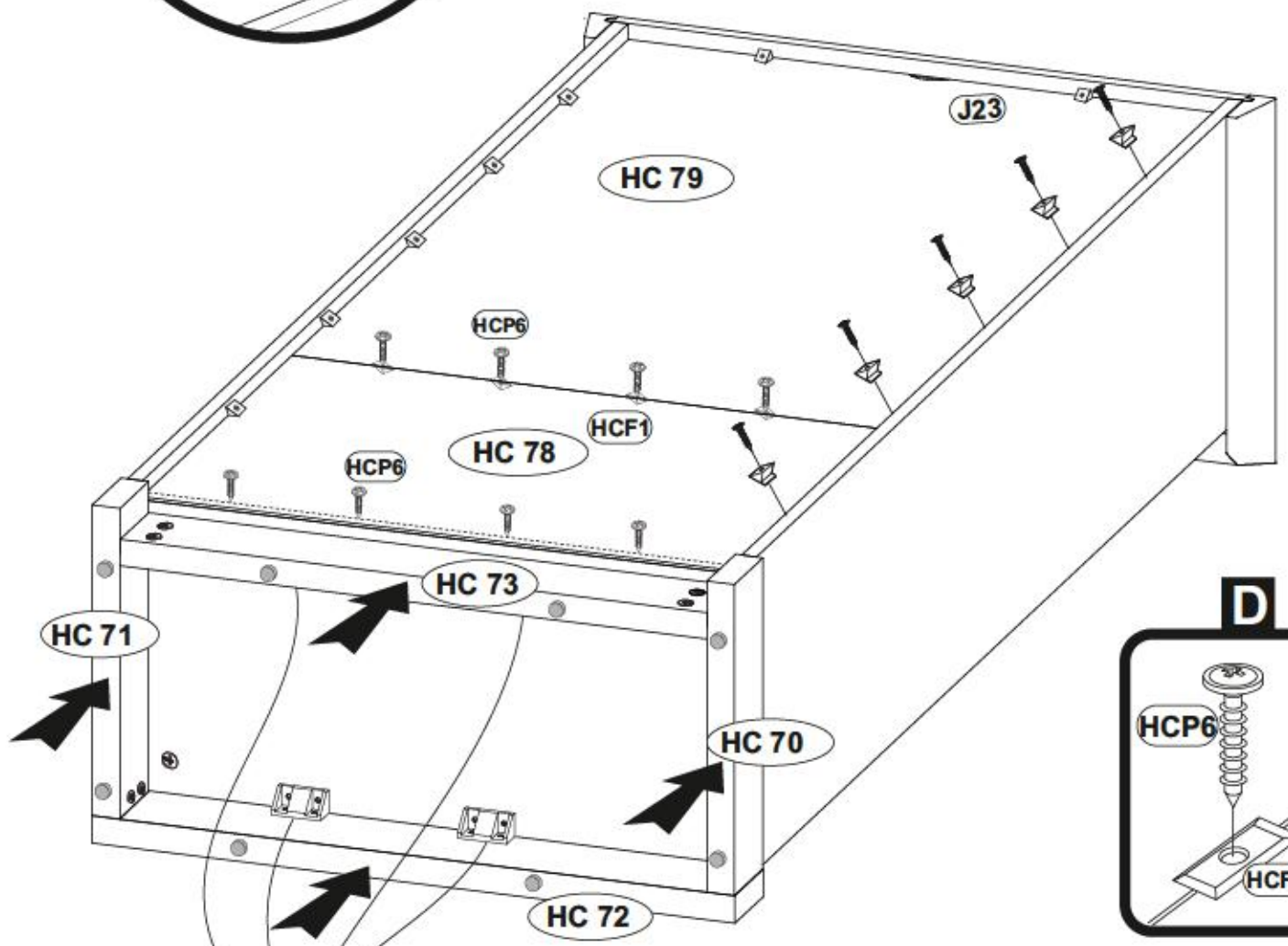
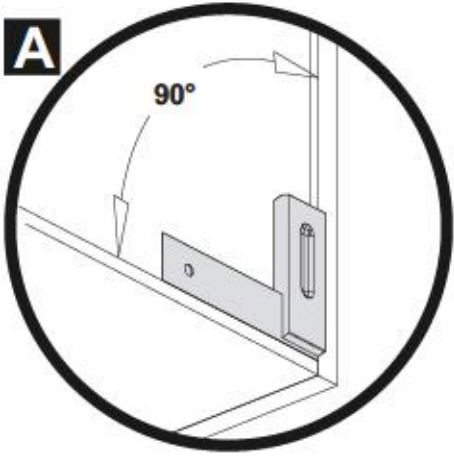

12

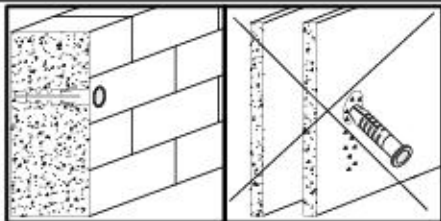

HCS3		1011
	3,5x13	x24
W1		1289
		x4
HCJ11		1267
		x1
HCC6		1423 18
	φ20	x8

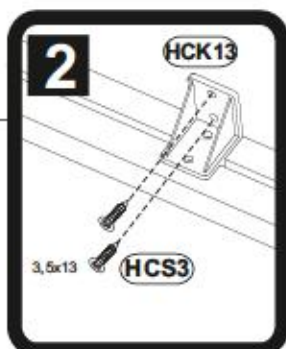
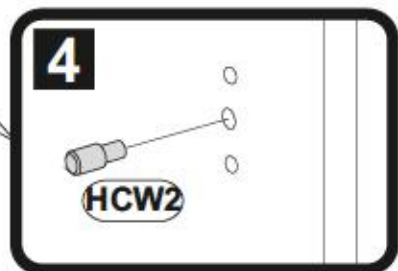
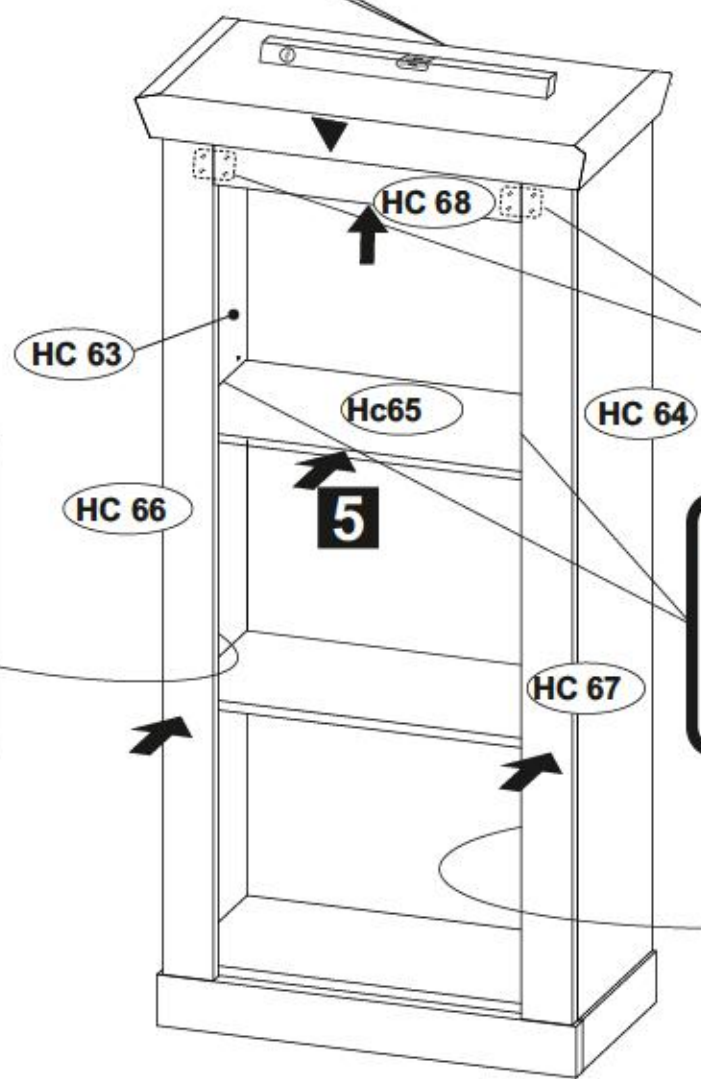
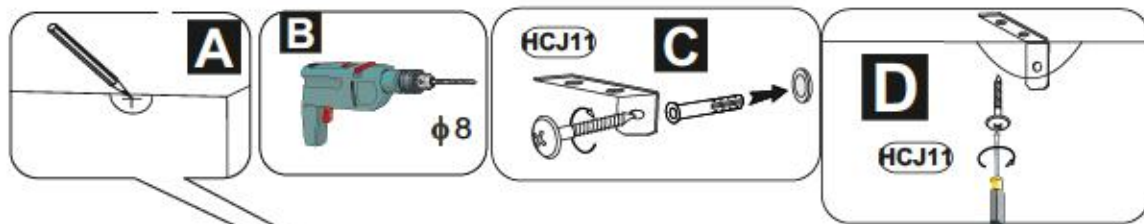

13

Option L



HCUC160		154322	x1
HCA4		14413	x3
WPM 4x18			x3
HCG54		126880	x1
HCP2		1014	x1
3,5x13			x1
HCUC1		154317	x1

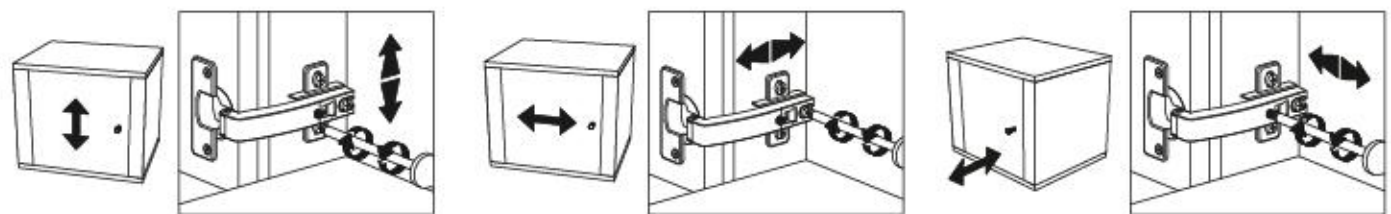
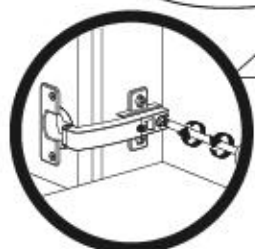
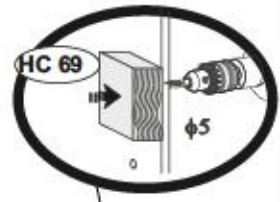
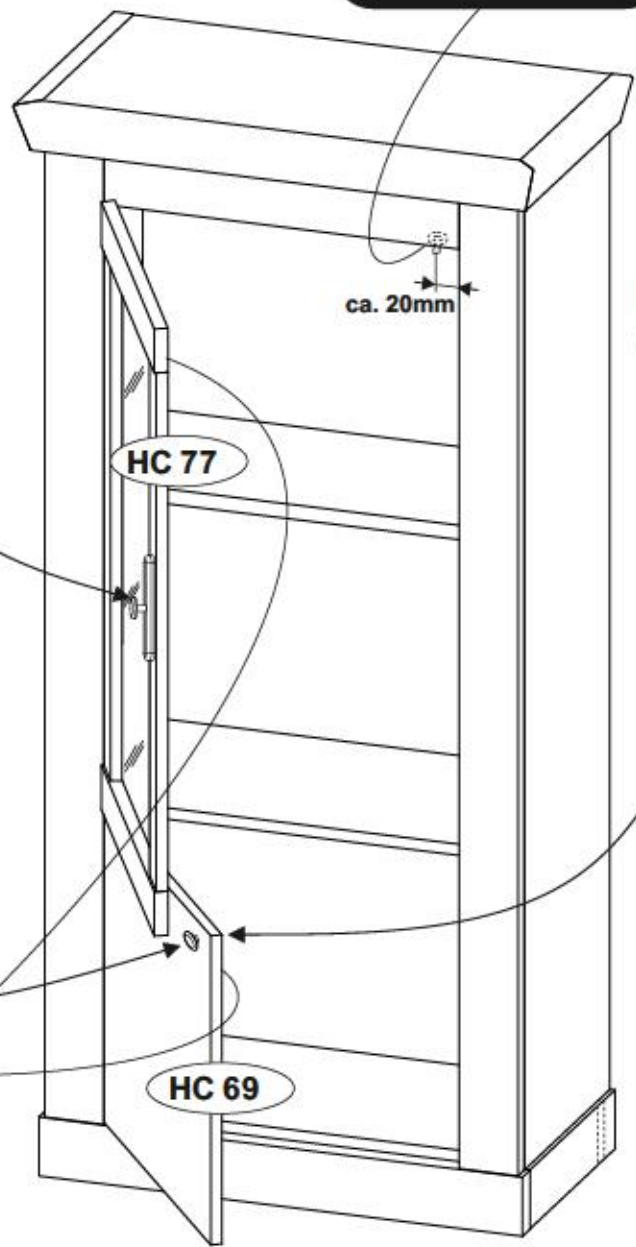
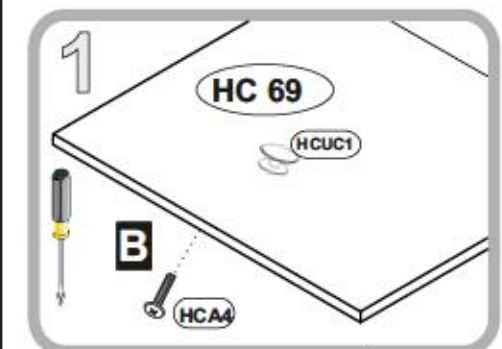
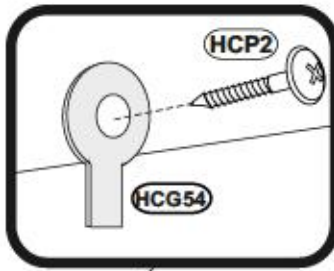
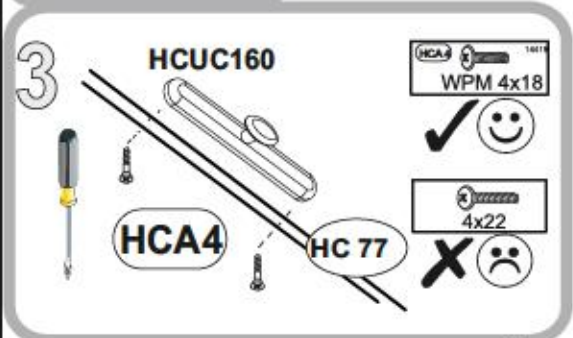
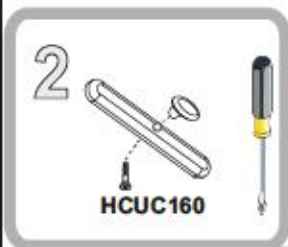

14

Option R

HCUC160		154838	x1
HCA4		14419	x3
WPM 4x18			x3
HCG54		128880	x1
HCP2		1014	x1
3,5x13			x1
HCUC1		154837	x1

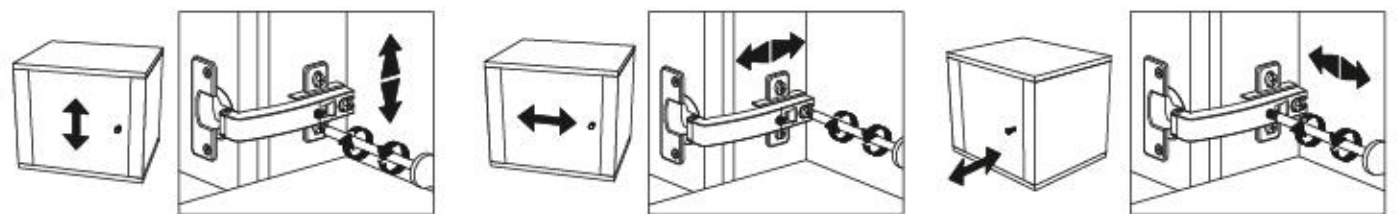
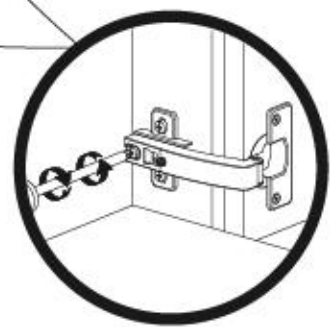
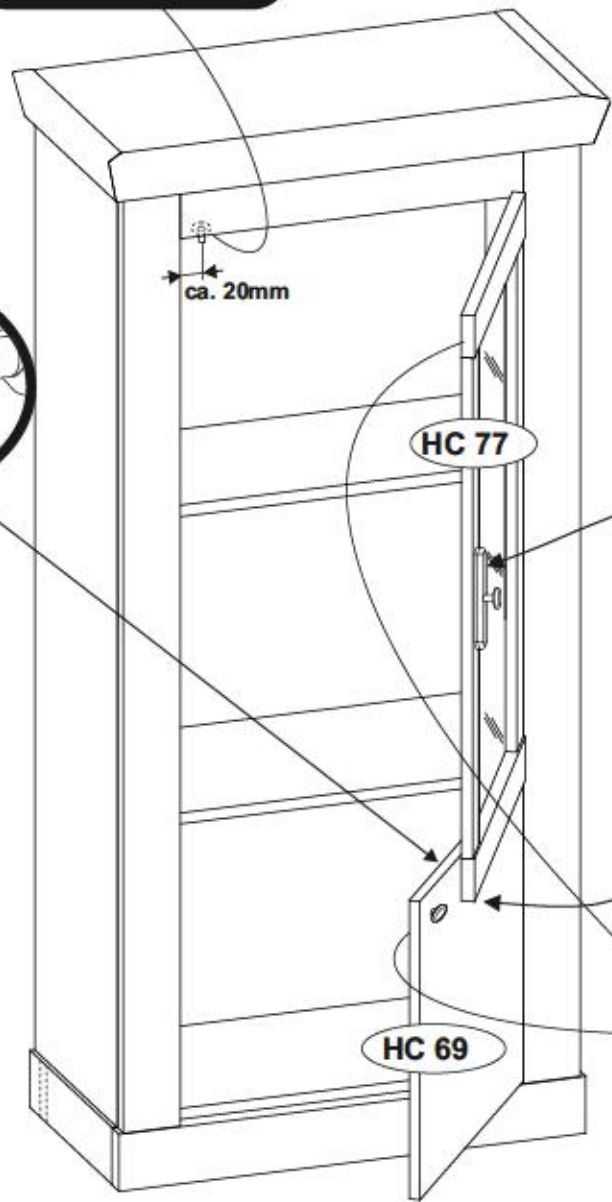
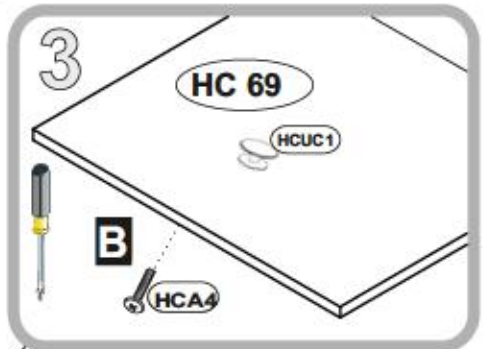
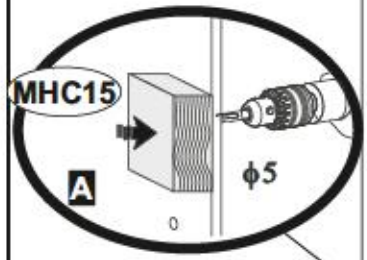
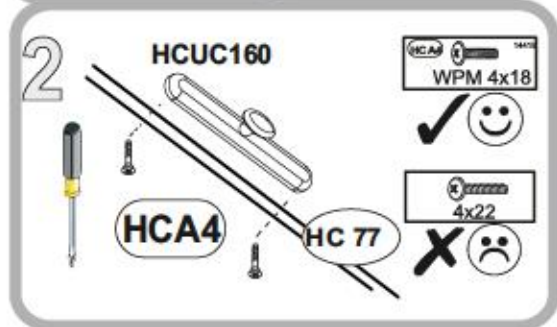
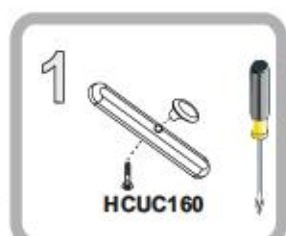
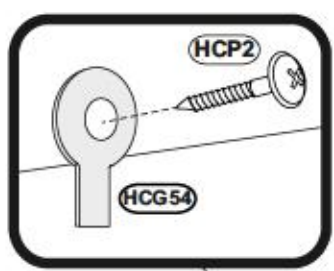

RAVENNA 22

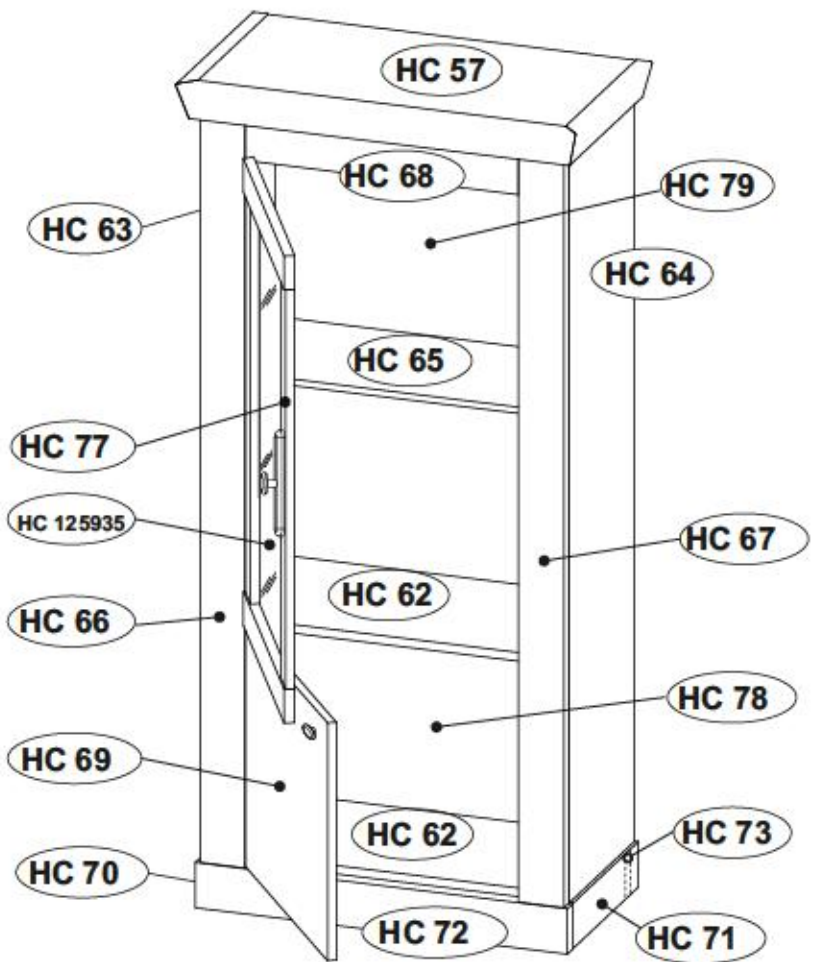

D Unser Drehschloß für Beschläge
 Sollte Ihnen ein Beschlag bei Ihnen, können Sie diese Servicekarte direkt an die untenstehende Adresse mailen. Wir können sie lediglich nur Beschlagteile auf diesem Wege verschicken. Sollten Sie eine andere Beschreibung an Ihrem Möbelstück haben, so wenden sie sich bitte direkt an Ihr Möbelhaus.

GB Our direct order service for fittings
 If a fitting part is missing, you can e-mail this service card directly to the address below. However, we can only send fitting parts in this way. If you have any other cause for complaint concerning your item of furniture, please contact your furniture store directly.

CZ Náš přímý službu pro kování
 Chybí-li vám nějaký díl z kování, můžete tuto službu kartou odešlat e-mailem přímo na níže uvedenou adresu. Touto cestou však můžete poslat jen díly kování. Pokud byste měli nějaký jiný problém, obraťte se přímo na svého prodejce nábytku.

F Bien sûr, nous avons le service de livraison
 Si vous manquez une ferrure, veuillez envoyer directement la présente carte service à l'adresse e-mail indiquée ci-dessous. Cependant, nous ne pouvons uniquement émettre de ferrures. Pour tout autre type de réclamation concernant votre meuble, veuillez contacter directement votre magasin d'ameublement.

I Il nostro servizio diretto per i ricambi delle ferrature
 Qualora Vi dovesse mancare un pezzo di fissaggio, allora Vi preghiamo di inviare questo card al servizio internettamente all'indirizzo sottostante. Possiamo inviare i pezzi di fissaggio solamente per mezzo di questo procedimento. Qualora ovverossia avete qualche altra reclamazione in merito al mobile, allora Vi preghiamo di rivolgerVi direttamente al Vostro Negozio di mobili.

BG Честит директен сервис за обзавеждане
 Ако липсва част от обзавеждането, потържете негово изображение и изпратете на е-mail адреса, по-долу. По този начин можем да доставим само обзавеждащите елементи от обзавеждането. Ако установите друга дефектна част, моля, свържете се с обзавеждащия или мебелизирания магазин, от който сте закупили стаята.

NL Onze direct service voor de aanpak van de
 Wanneer er een onderdeel ontbreekt, kunt u deze servicekaart direct aan ons direct order e-mailadres sturen. Wij kunnen lange deze weg echter alleen de aanpak van de onderdelen. Mocht u een ander probleem aan uw meubel hebben, verzeeven wij u contact op te nemen met uw meubelwinkel.

PL Nasz bezpośredni serwis zamków i kluczy
 Jeżeli brakuje części zamkowej do mebla, prosimy o przesłanie nam niniejszej karty serwisowej na niżej podany adres e-mailowy. W ten sposób możemy przysłać Państwu tylko brzojowe części. W przypadku innych reklamacji dotyczących mebla, prosimy zgłosić je do własnego meblowego, w którym zostały dokonany zakup.

HR Servis za otkaz
 U slučaju da nedostaje neki od dijelova meblara, važno je da je nedostajuć dio direktno pošaljete na ovaj e-mail adresu. Na ovaj način mogu se dostaviti samo dijelovi. U slučaju da imate bilo koju drugu prigovore vezane uz karmel namještaja, molimo vas da se obratite izravno trgovini namještaja gdje je isti kupljen.

HU Direktszolgálatok az ajtózávarókhoz
 Ha hiányzik egy závaró, azt e-kéntje kitöltve küldheti az alábbi e-mail címre. Azonban csak závarókat tudunk így küldeni. Amennyiben másféle problémát észlel a furnél birtokosként, forduljon közvetlenül a boltjához.

SK Náš priamy servis pre zámky a kľúčy
 Ak by Vám chýbala niejaká časť zámka, môžete poslať túto službu kartu priamo e-mailom na nižšie uvedenú adresu. Čiaky kovánie a iné príslušenstvo môžeme poslať iba touto cestou. Ak by ste mali iný problém, obráťte sa priamo na Vašu predajňu nábytku.

SLO Náš direktni servis za ključne inženjere
 Če vam manjka kakšno obovje, lahko to storimo kar direktno pošljete na spodnji elektronski naslov. Po tej poti vam lahko pošljemo samo obovje. Če želite nekakšno reklamacijo drug del pohištva, se obrnite neposredno na vašo trgovino pohištva.

RO Serviciu de servicii directe pentru feronerie
 În cazul în care vă lipseşte o piesă de feronerie, puteţi să trimiteţi cardul acesta direct la adresa prin e-mail de mai jos. Noi nu putem să trimitem decât piese de feronerie doar pe această cale. Dacă a veşti o altă reclamaţie referitoare la piesa de mobilier, atunci vă rugăm să vă adresaţi direct la magazinul dvs. de mobilă.

RUS Наш прямой сервис для поставки фурнитуры
 Если отсутствует, что либо из элементов фурнитуры, Вы можете отправить сервисную карту по факсу или непосредственно на нижеприведенный адрес электронной почты. Однако, только с помощью этого способа мы сможем доставить лишь фурнитуру. Если же у Вас возникнут иные претензии относительно приобретенной мебели, пожалуйста, обращайтесь непосредственно в организацию, осуществляющую продажу.

S Náš direktni servis za besedilne kartice
 Om du mangler en besedilne kartice, kan du skicka det här servicekort direkt till e-postadressen som angivses nedan. Vi kan på detta sätt endast skicka besedilne kartice besedilne kartice till dig. Om du vill skicka en annan typ av besedilne kartice, du kan kontakta ditt möbelhus direkt.

ES Nuestro servicio directo para accesorios
 Si le falta algún accesorio, puede enviar este tarjeta de servicio de directamente a la siguiente dirección. No obstante, por este método solo podemos enviar accesorios. Si tiene alguna otra objeción sobre su mueble, consulte directamente con su mueblería.

TR Doğrudan sipariş doğrudan servisi
 Bir donanım eksikliği ya da aksesuarı doğrudan sipariş edebilirsiniz. Bu şekilde sadece doğrudan sipariş edilebilir. Diğer donanım ve aksesuarlar için doğrudan sipariş edilebilir. Mobilyanızda başka şikayetleriniz varsa lütfen doğrudan mobilya satıcınıza danışın.

HC 57	x1	702	372	65	1/1						
HC 62	x2	611	299	15	1/1	HC 70	x1	317	80	28	1/1
HC 63	x1	1361	320	15	1/1	HC 71	x1	317	80	28	1/1
HC 64	x1	1361	320	15	1/1	HC 72	x1	656	80	28	1/1
HC 65	x1	610	273	22	1/1	HC 73	x1	598	80	28	1/1
HC 66	x1	1361	80	22	1/1	HC 77	x1	813	477	18	1/1
HC 67	x1	1361	80	22	1/1	HC 78	x1	417	623	3	1/1
HC 68	x1	483	124	18	1/1	HC 79	x1	949	623	3	1/1
HC 69	x1	415	477	15	1/1	HC 125935	x1	723	386	4	1/1

RAVENNA 23

Option L



Option R

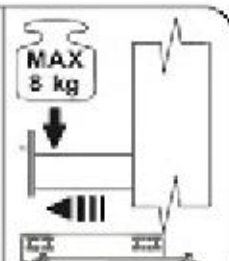
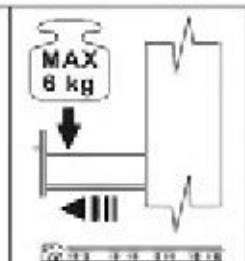
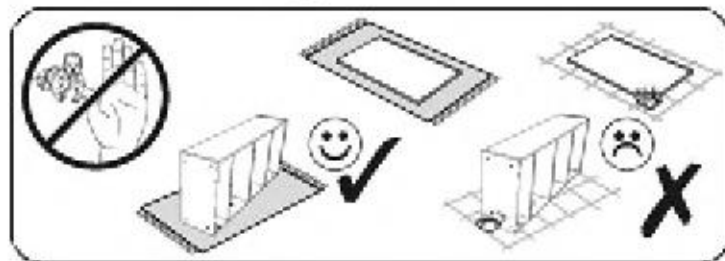
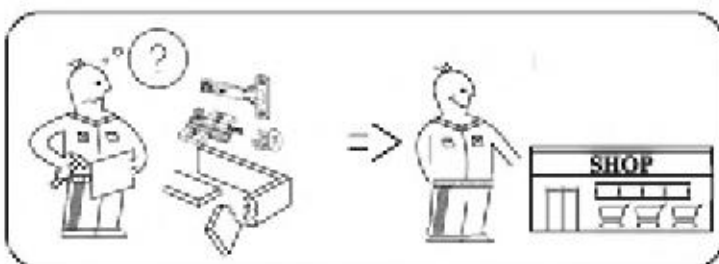
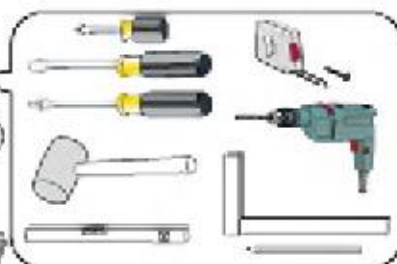
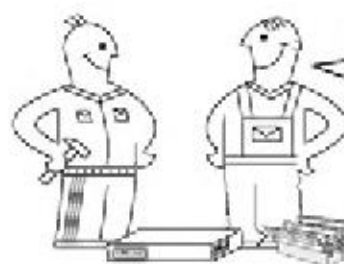
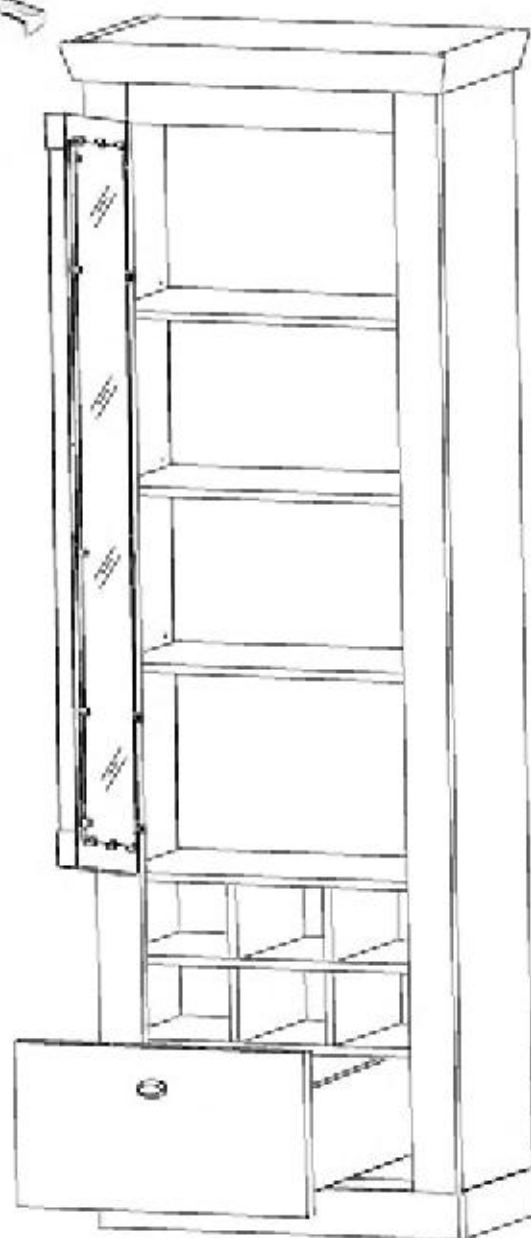

RAVENNA 23



max.



HC 85 HC 65
HC 86 HC 87

max.



HC 83

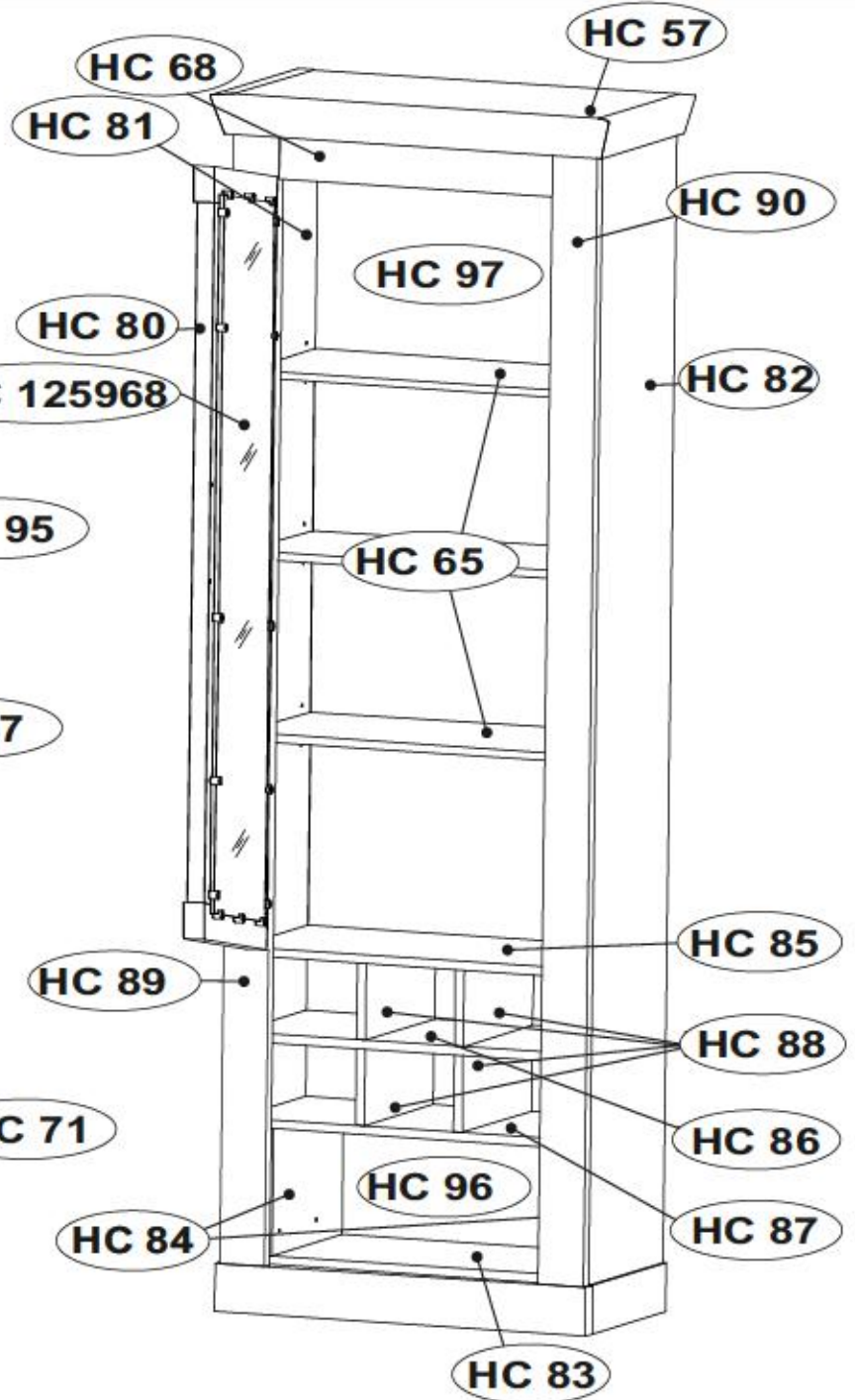
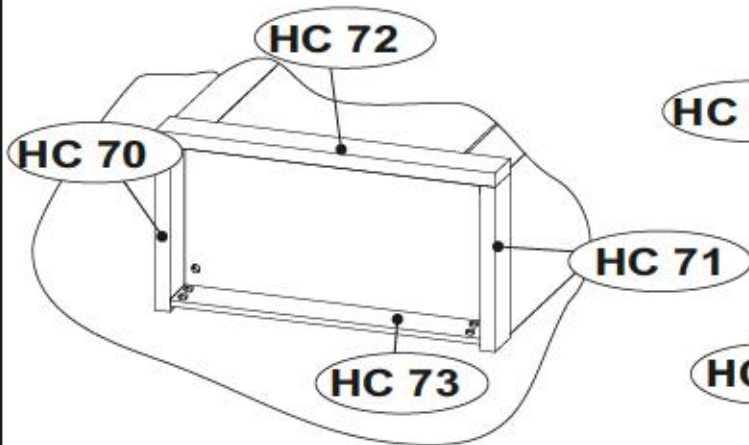
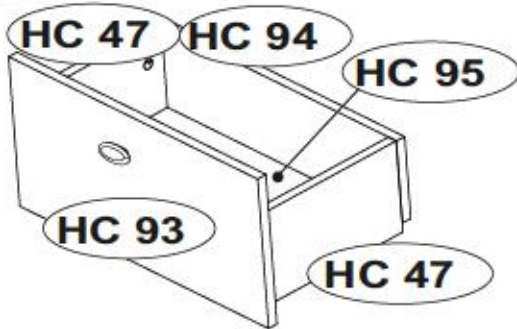









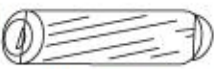

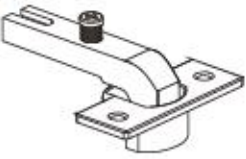



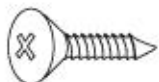







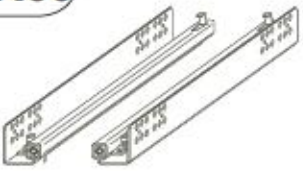
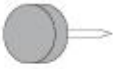

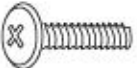
HC 47	x2	237	140	15	2/2
HC 57	x1	702	372	65	1/2
HC 65	x3	610	273	22	1/2
HC 68	x1	483	124	18	2/2
HC 70	x1	317	80	28	1/2
HC 71	x1	317	80	28	1/2
HC 72	x1	656	80	28	1/2
HC 73	x1	598	80	28	1/2
HC 80	x1	1279	477	18	2/2
HC 81	x1	1911	320	15	2/2
HC 82	x1	1911	320	15	2/2
HC 83	x1	611	299	15	1/2

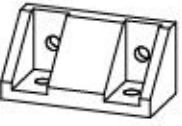

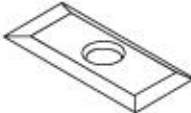
HC 84	x2	209	250	15	2/2
HC 85	x1	611	299	15	1/2
HC 86	x1	611	299	15	1/2
HC 87	x1	611	299	15	1/2
HC 88	x4	124	298	15	2/2
HC 89	x1	1911	80	22	2/2
HC 90	x1	1911	80	22	2/2
HC 93	x1	477	230	15	2/2

HC 94	x1	466	126	15	2/2
HC 95	x1	447	258	2.5	2/2
HC 96	x1	368	623	2.5	2/2
HC 97	x1	1546	623	2.5	2/2
HC 125968	x1	1189	386	4	2/2

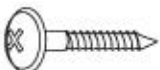
RAVENNA 23

HCB1  1018 8x28 x52	HCG5  1356 x16	HCZ4  49365 φ35 90° x3
HCM1  1336 x28	HCS11  1073 3x16 x16	
HCT1  1336 x28	HCS3  1011 3,5x13 x78	HCF14  1021 x2
HCJ23  1302 x16	HCK13  49716 x12	HCF44  116795 x1
HCW1  1289 x12	HCUC160  154536 x1	
HCC6  140318 φ20 x8	HCJ11  1267 x1	HCR60  140806 250 x1
HCF36  1305 x8	HCP6  1056 3x20 x11	
HCA4  14419 WPM 4x18 x3	HCE1  1008 ES 6,3x9,5 x4	HCK15  81556 x4
HCG54  126680 x1	HCF1  1415 x4	HCUC1  154537 x1
HCK1  1354 7x50 x4	HCD14  23515 H4 x3	HCP2  1014 3,5x13 x1

1

HCB1		10 18
	8x28	x8
HCM1		123894
		x4
HCT1		118 00
		x4

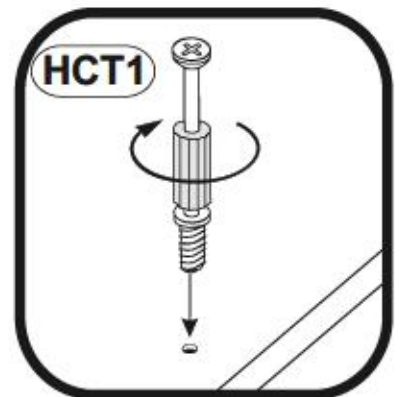
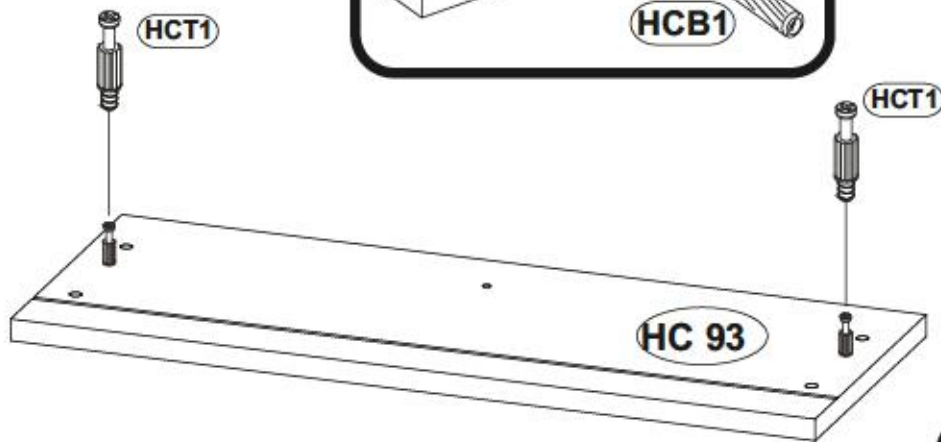
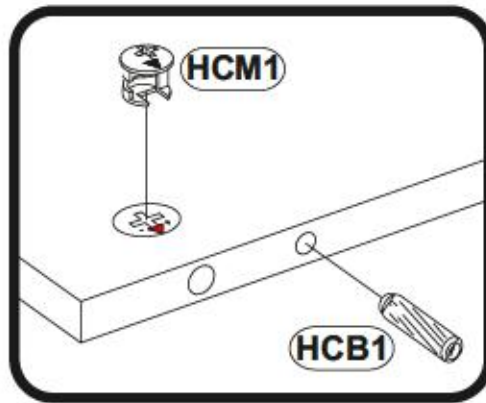
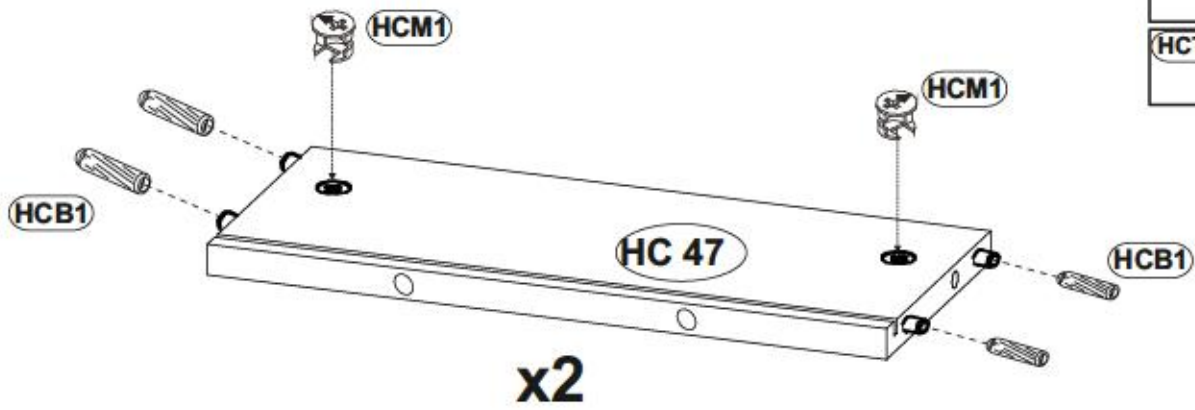

2

HCJ23  1302
x2

HCP6  1058
3x20 x3

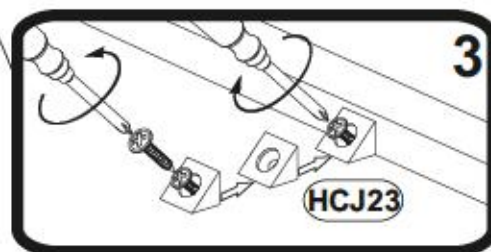
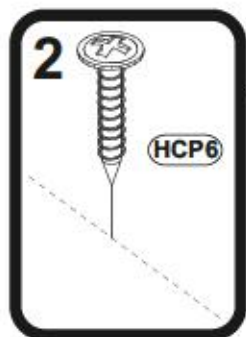
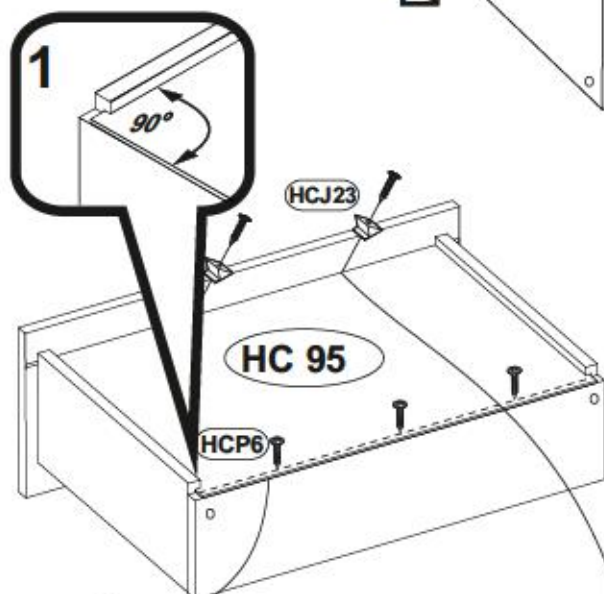
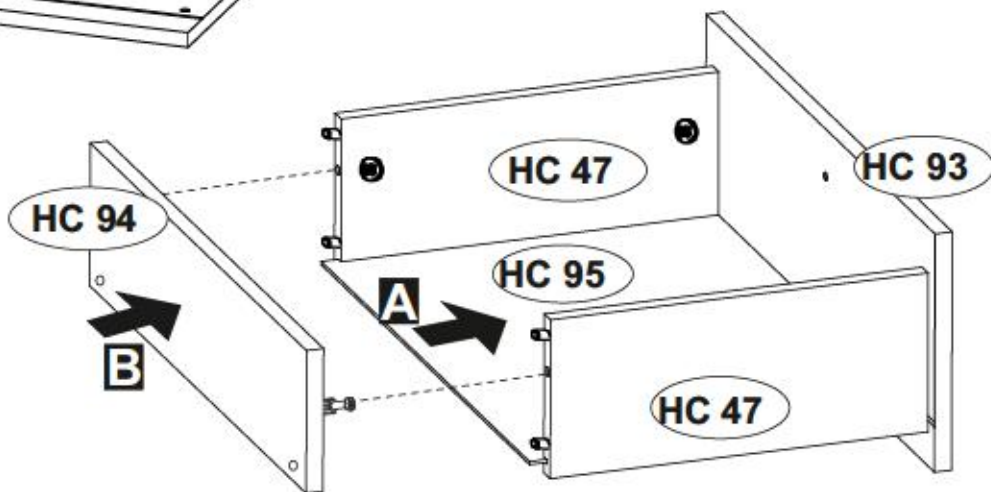
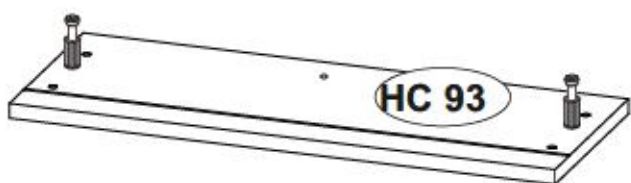
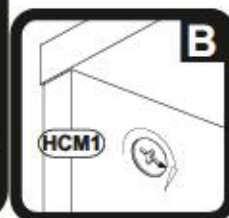
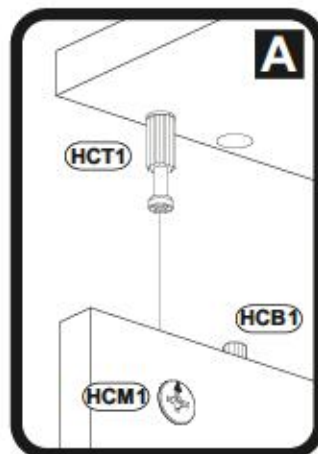
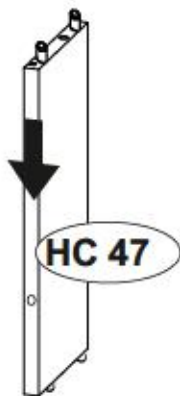
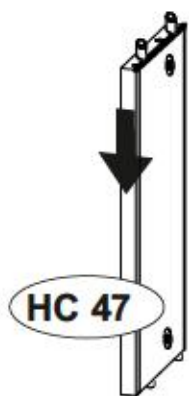

3

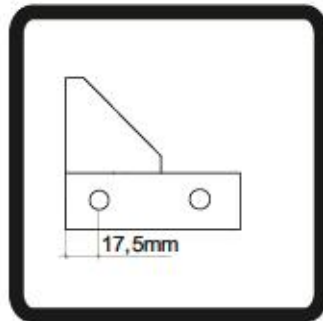
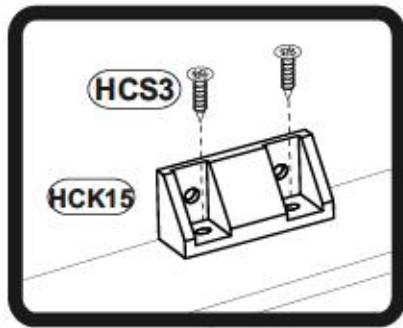

HCM1		12 38 94	x8
HCT1		11 80 9	x8
HCS3		10 11	x8
HCB1		10 16	x4
HCK15		01 05 6	x4

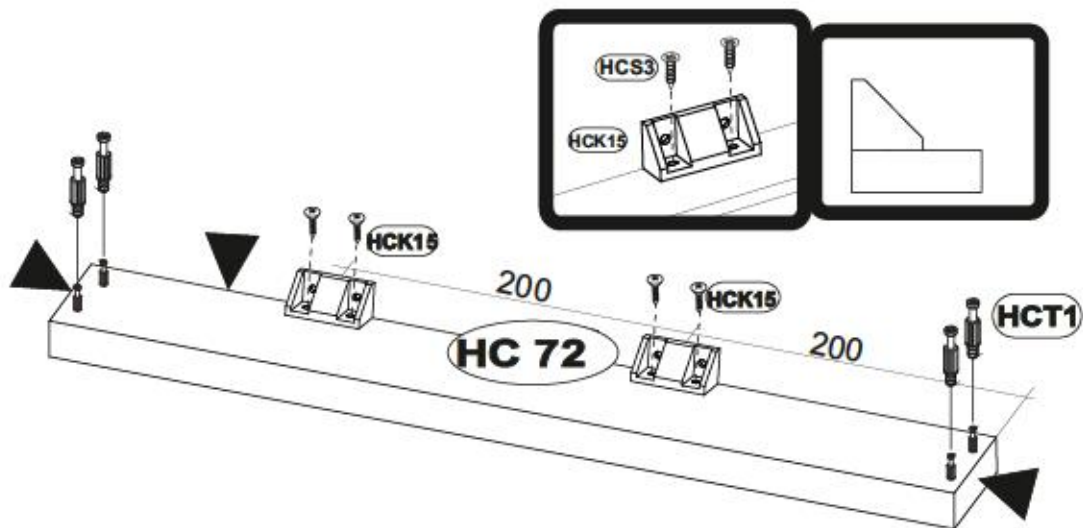
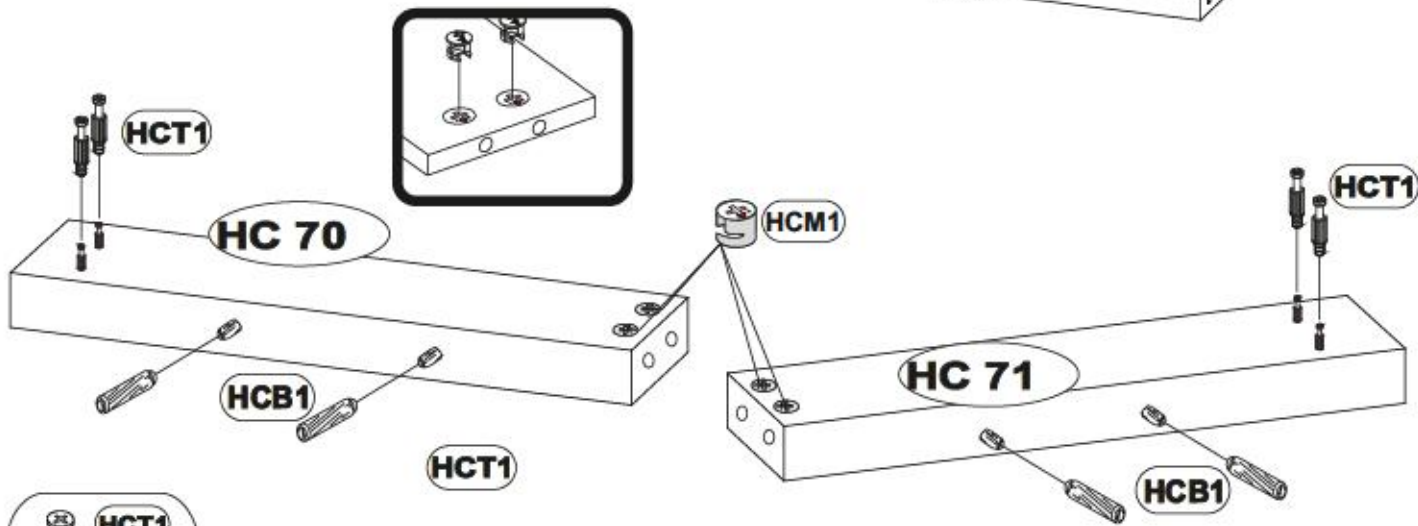
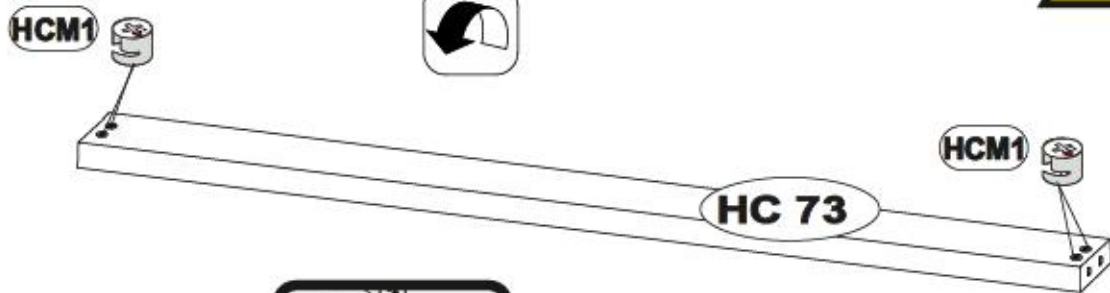
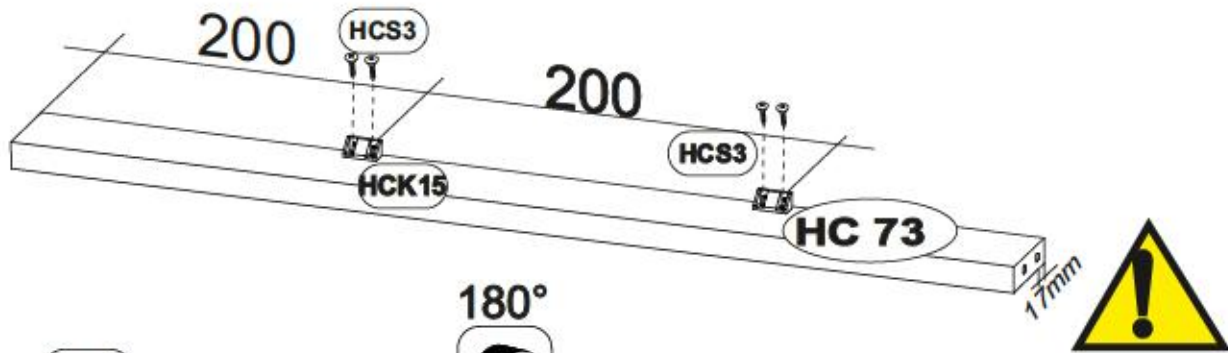

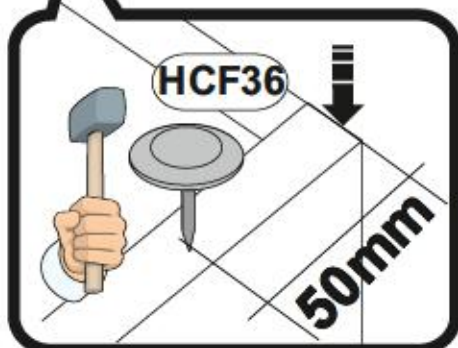
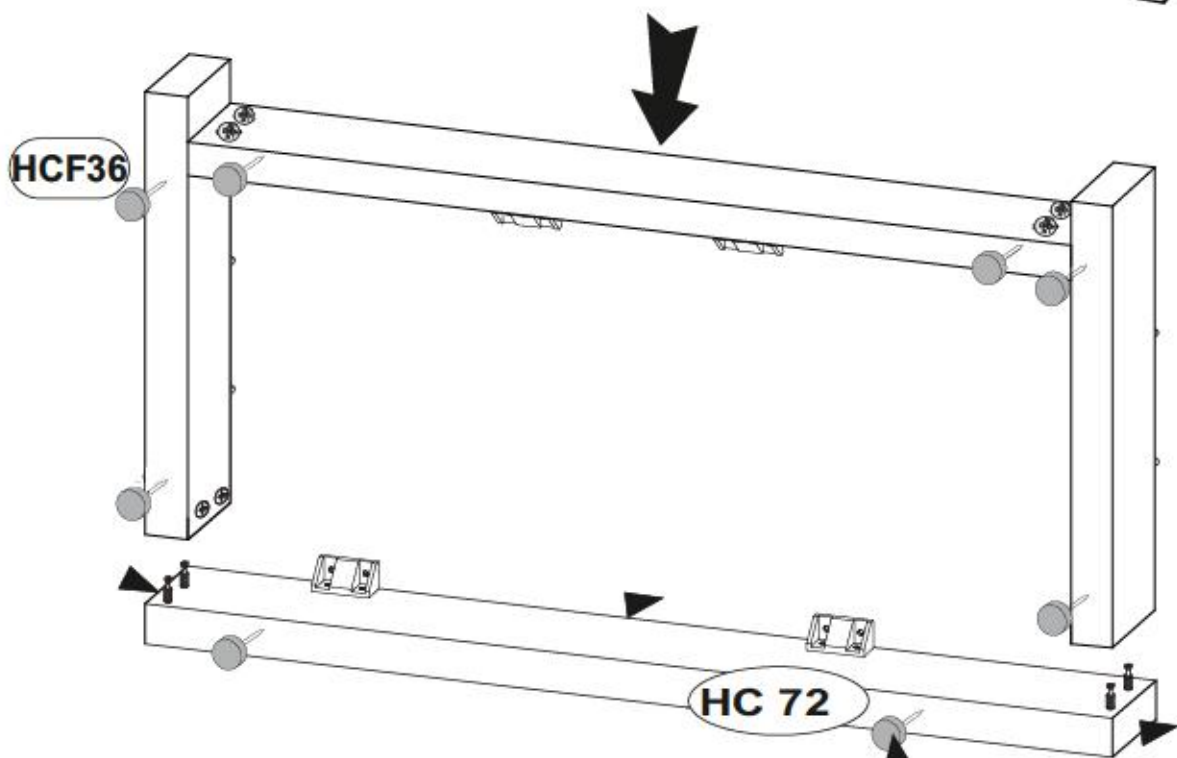
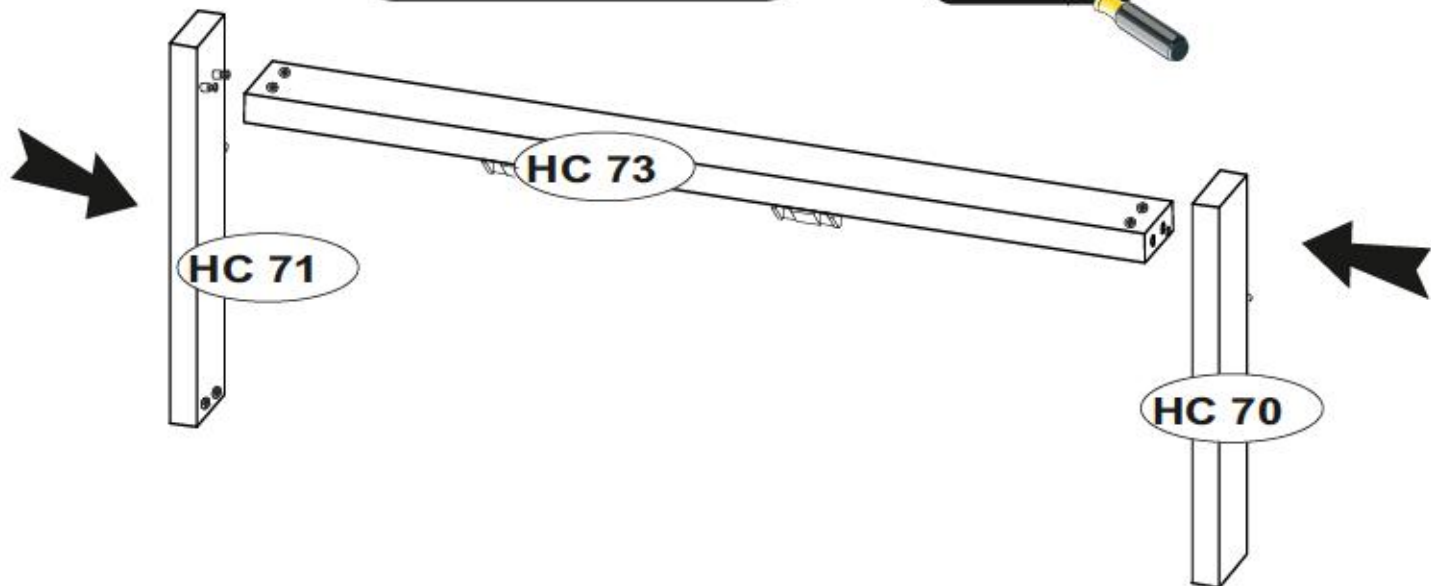
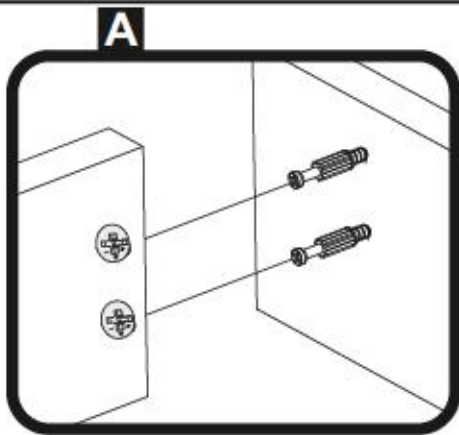

4

HCF36 1305
x8





5

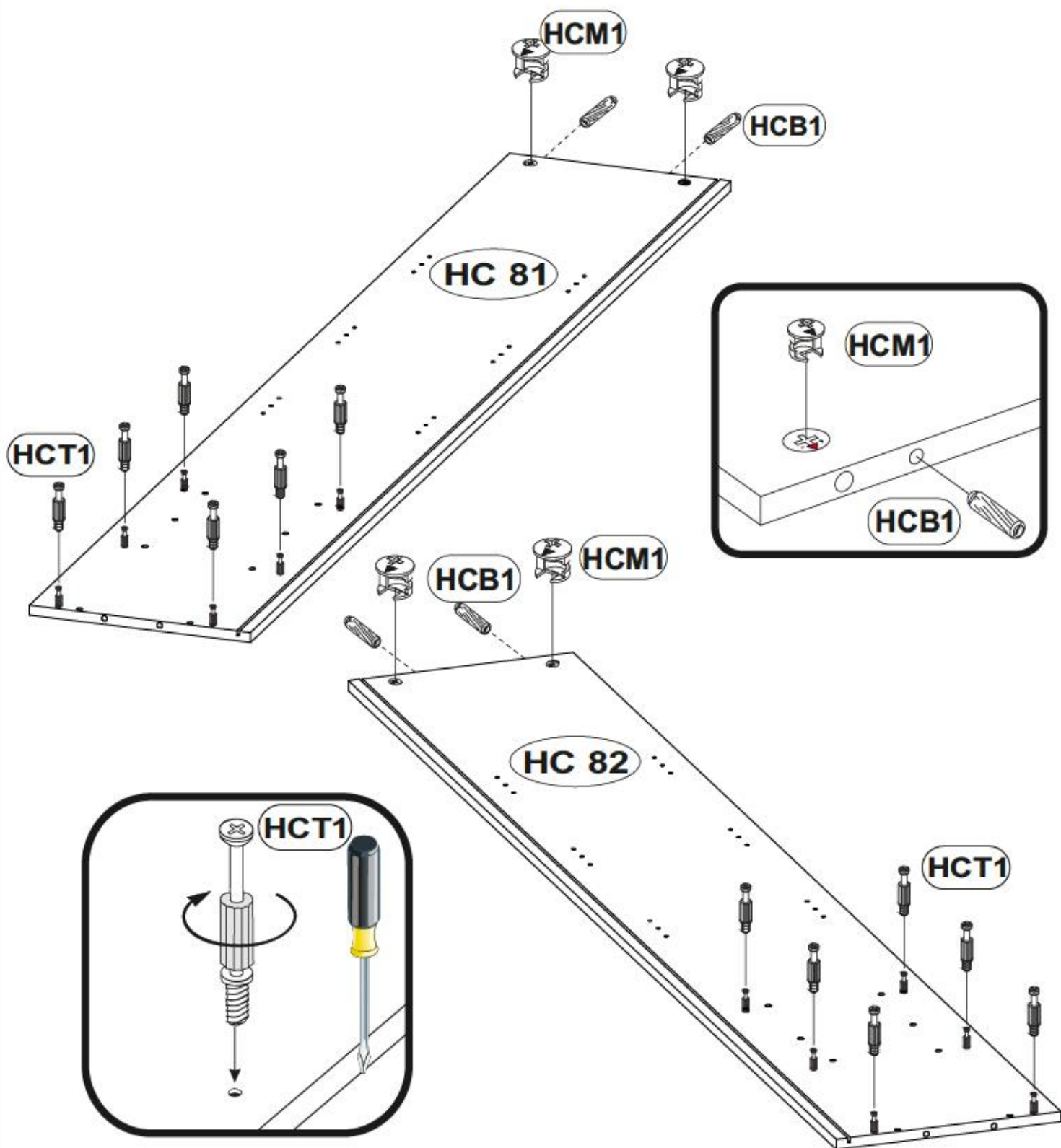



HCB1		10 28
	8x28	x4
HCM1		129804
		x4
HCT1		11809
		x12

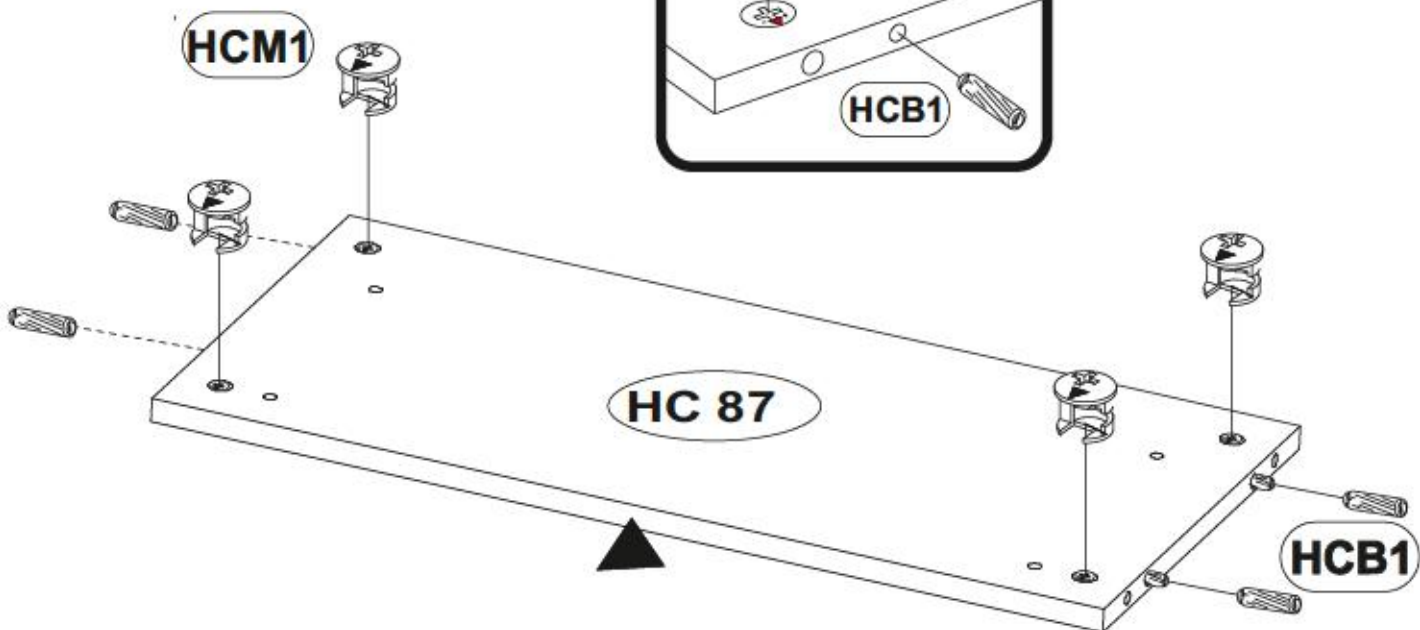
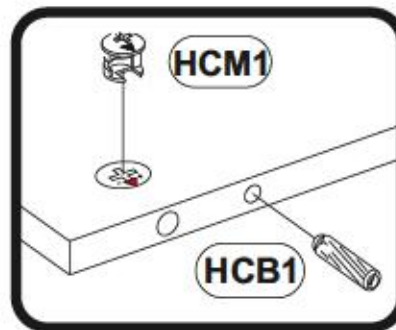
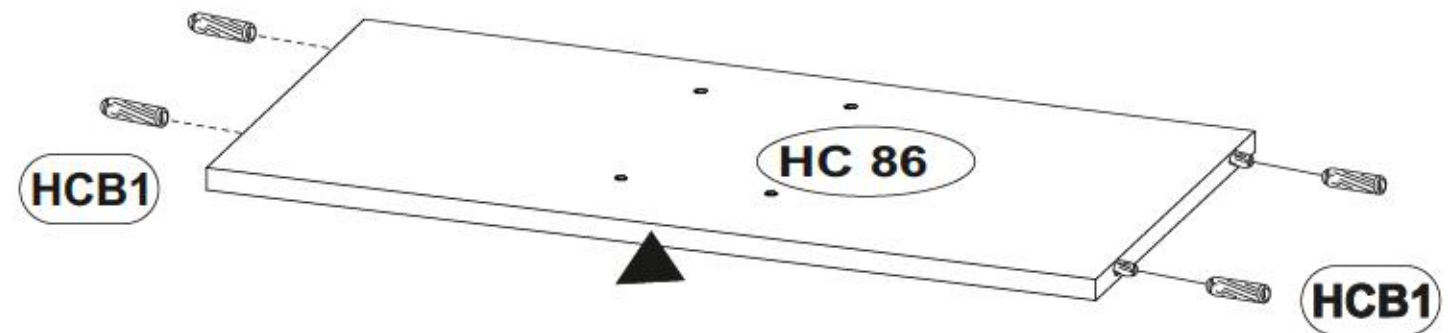
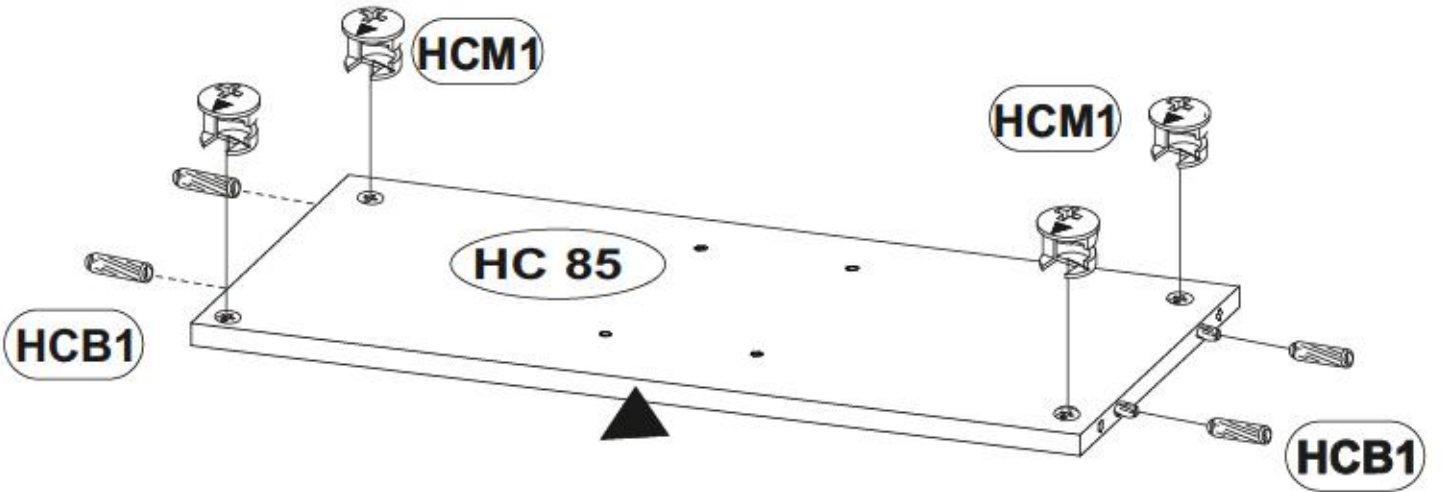
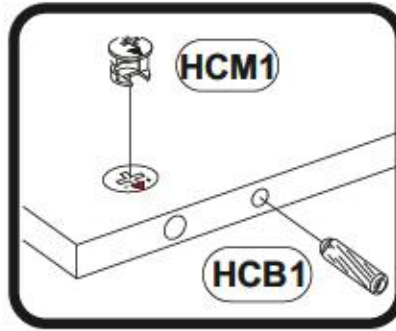

6

HCM1		1.25x8x4	x8
HCB1		8x28	x12



HCS3		1011	HCM1		1338
	3,5x13	x4			x4
HCB1		1098			
	8x28	x20			
HCF14		9021			
		x2			

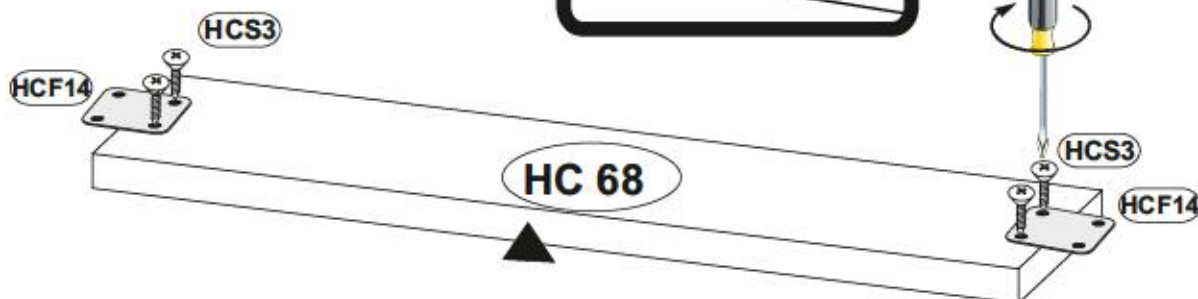
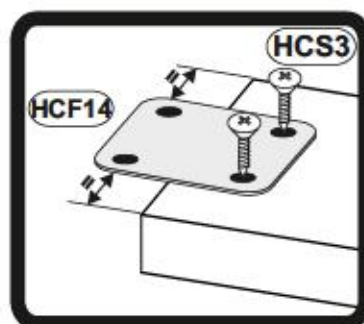
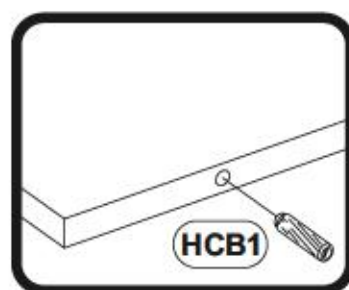
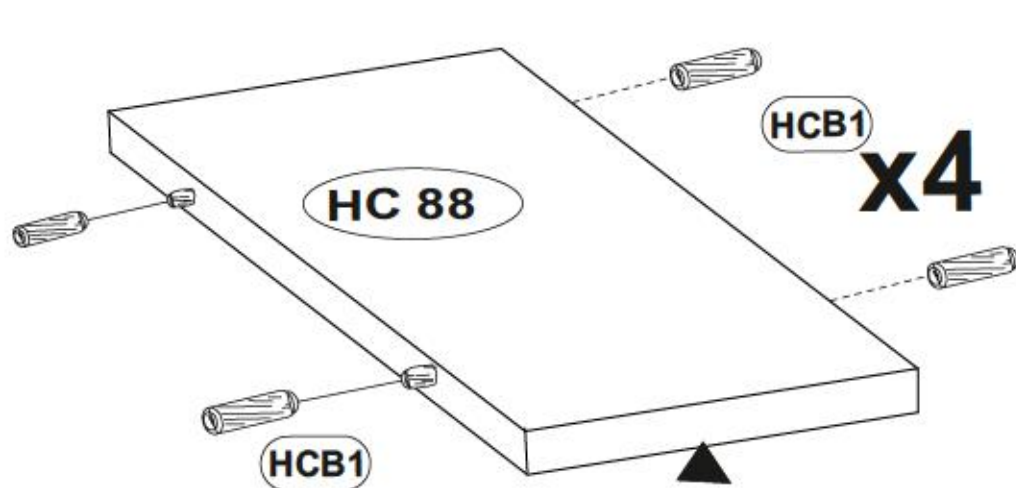
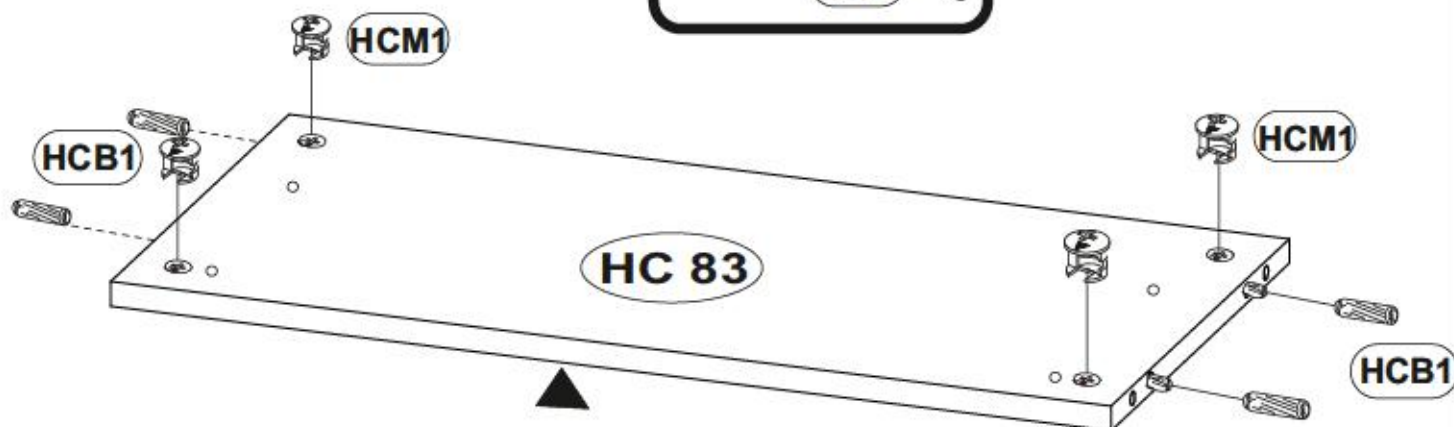
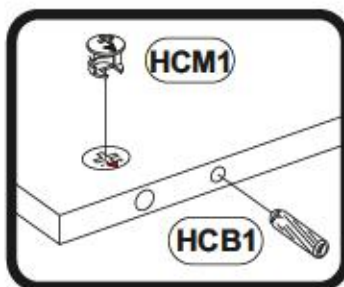

8

OPTION L

HCK13		49718
		x12
HCD14		23515
	H4	x3
HCS3		1011
	3,5x13	x24

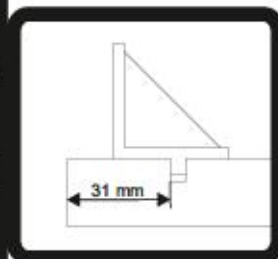
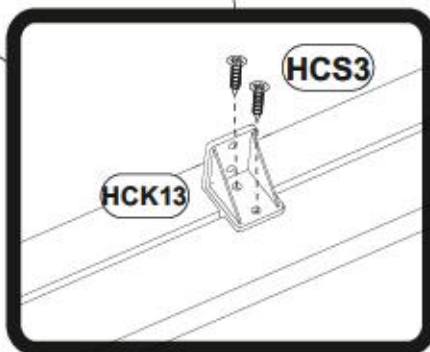
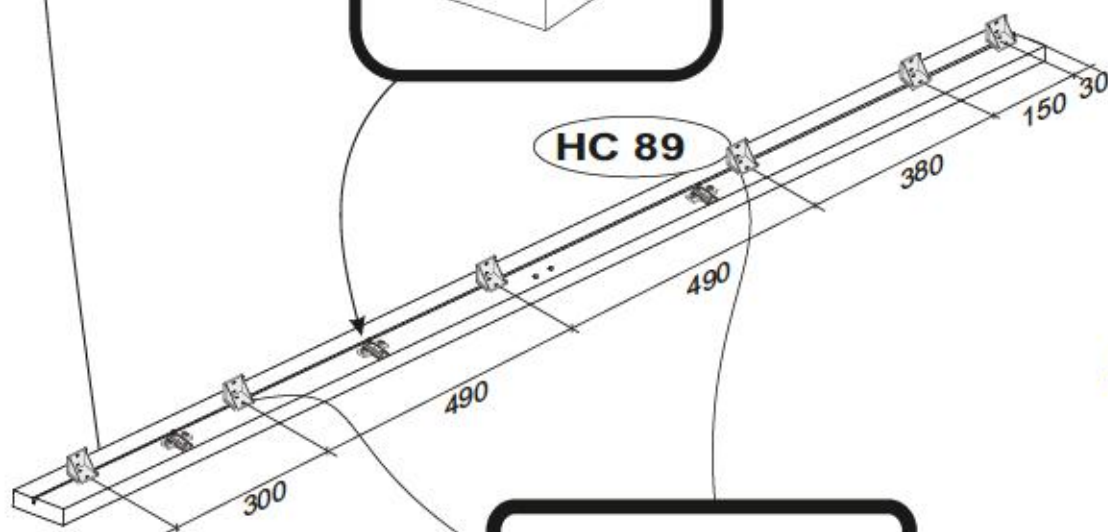
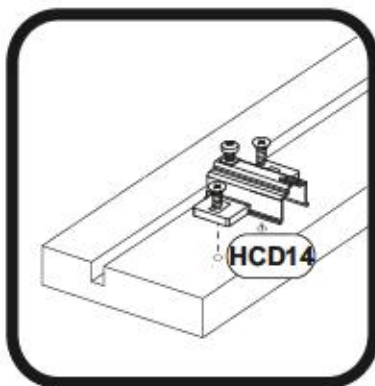
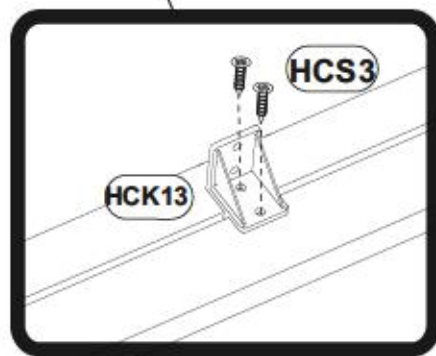
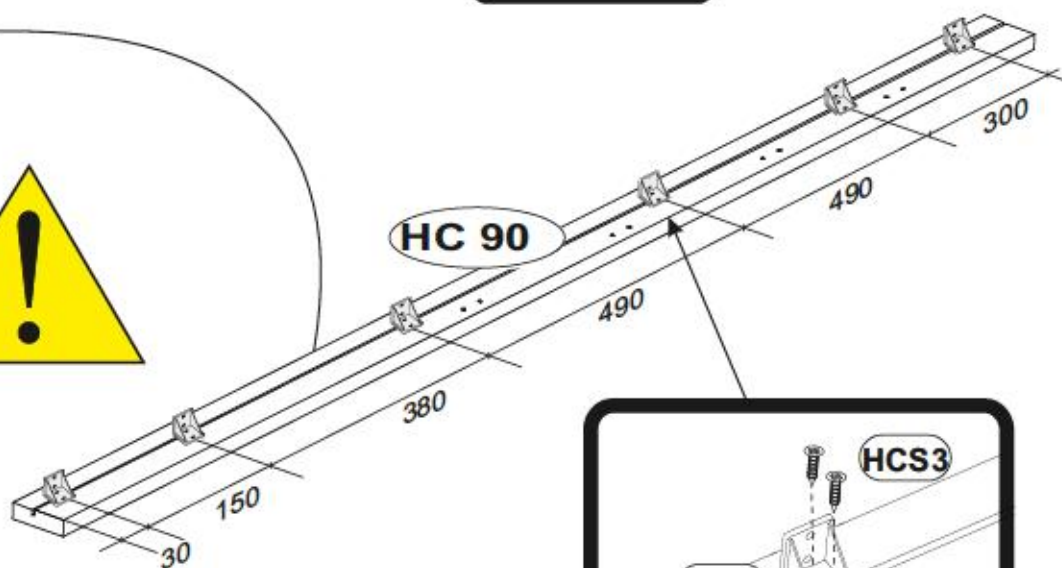
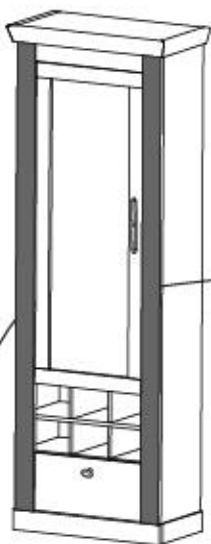
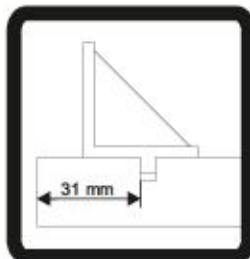

9

OPTION R



HCK13		49716	x12
HCD14		28915	x3
HCS3		1011	x24
		3,5x13	

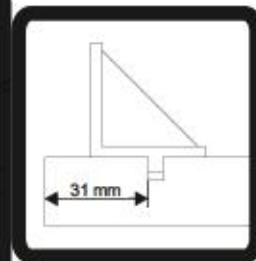
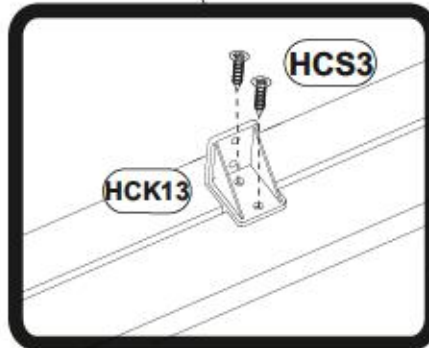
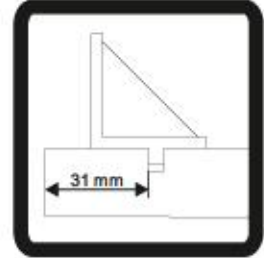
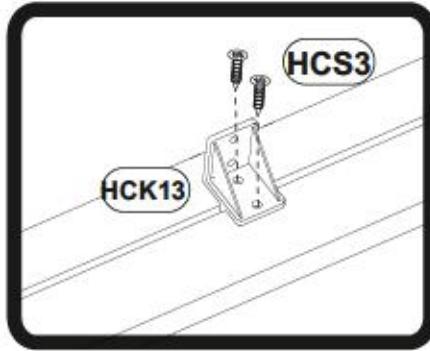
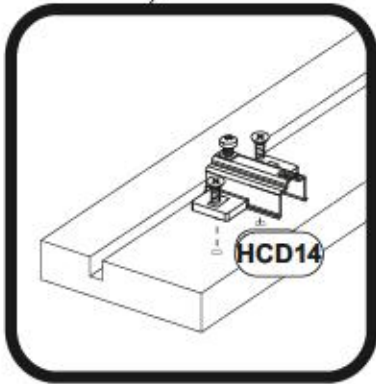
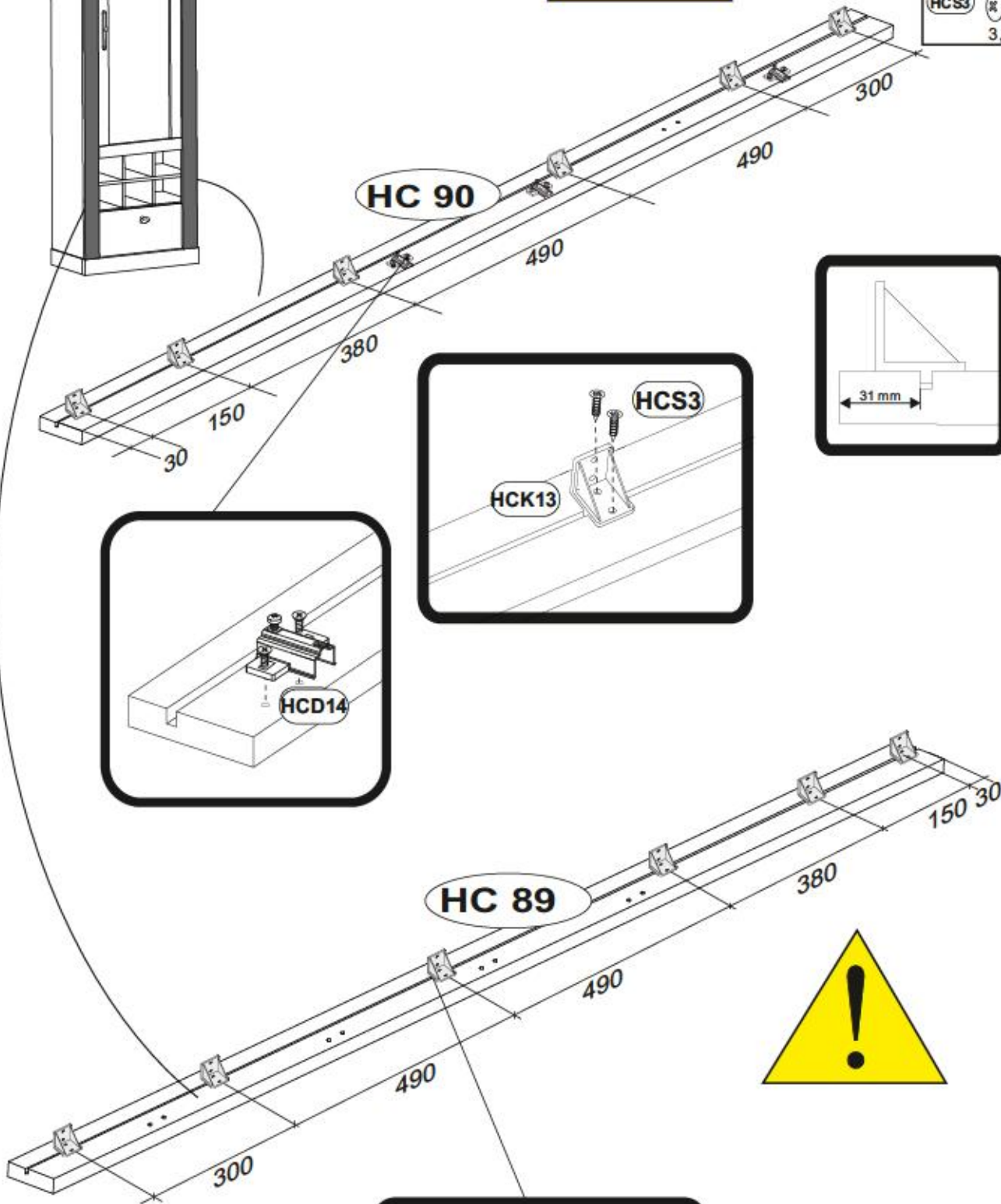
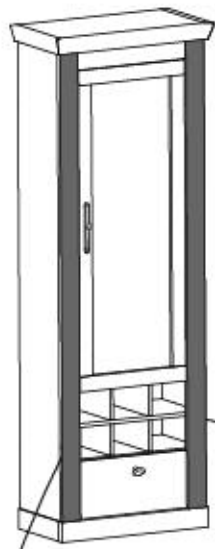

10

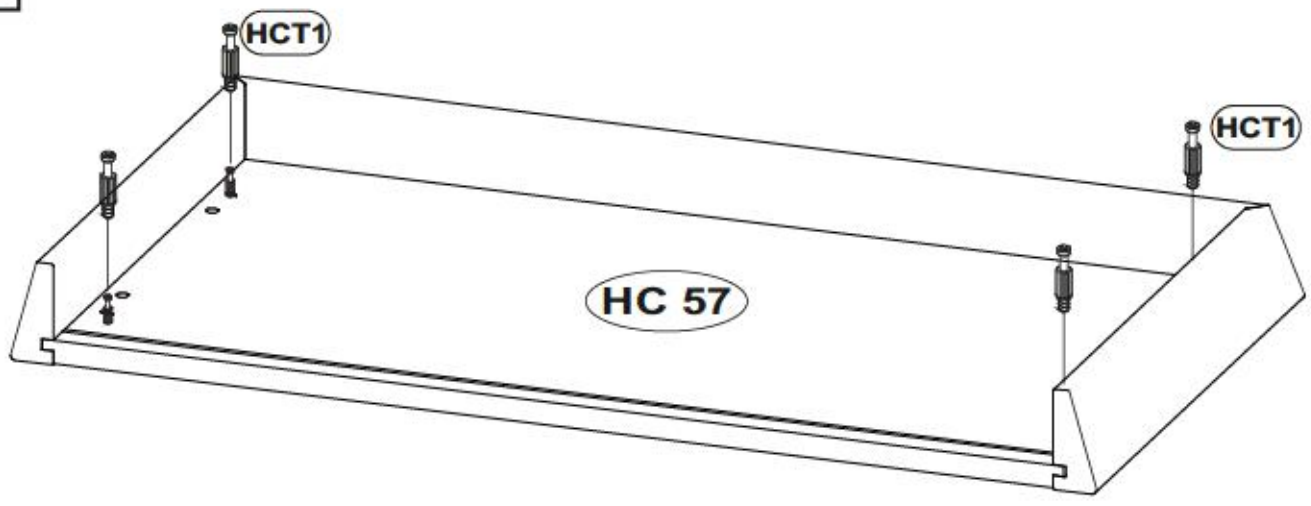
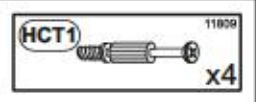

11

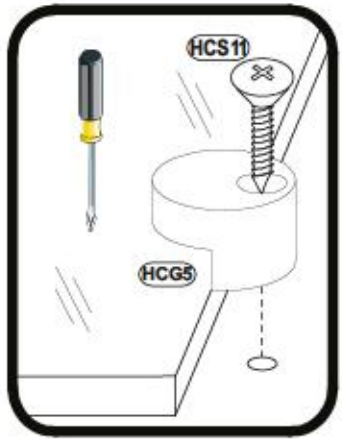
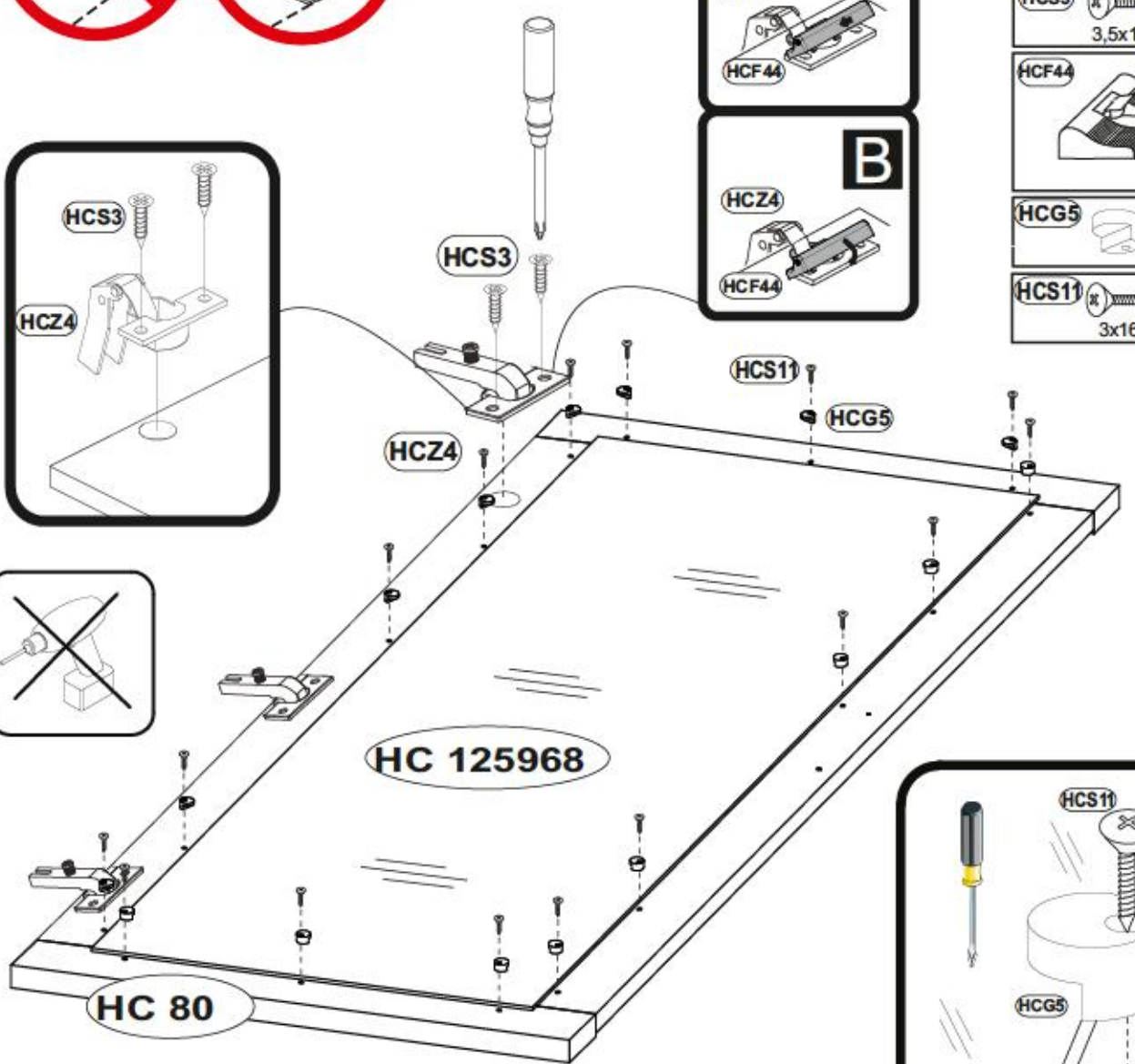
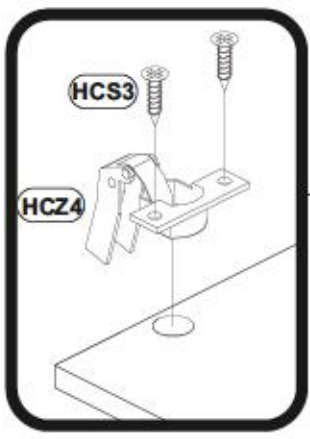
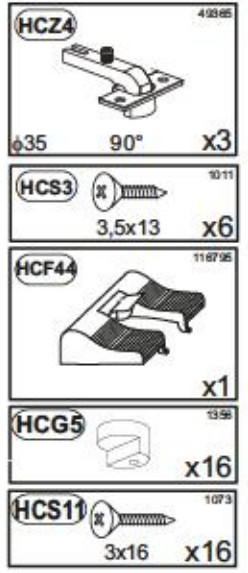
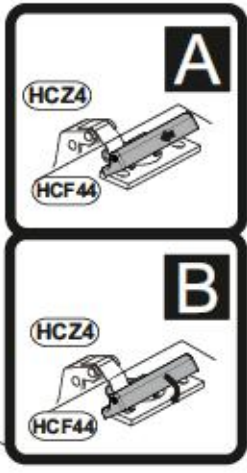

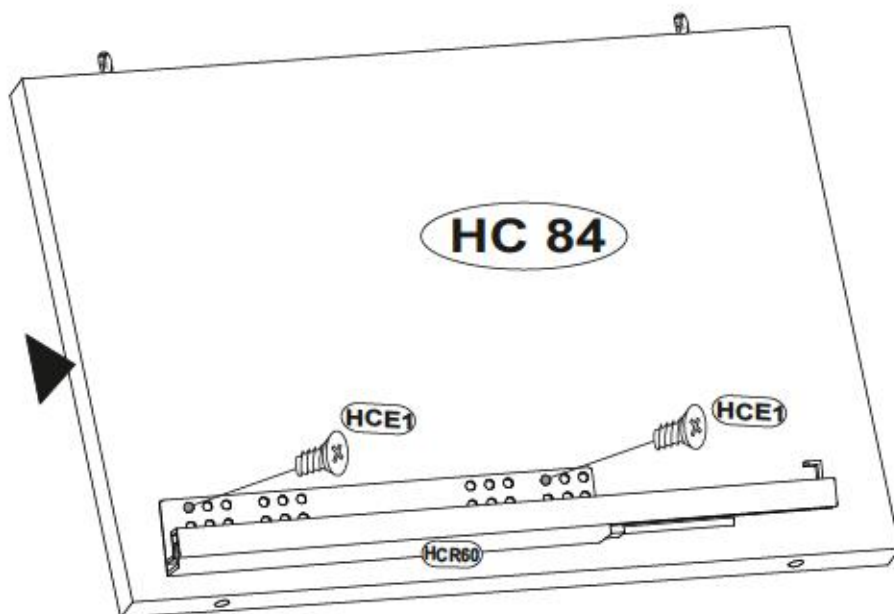
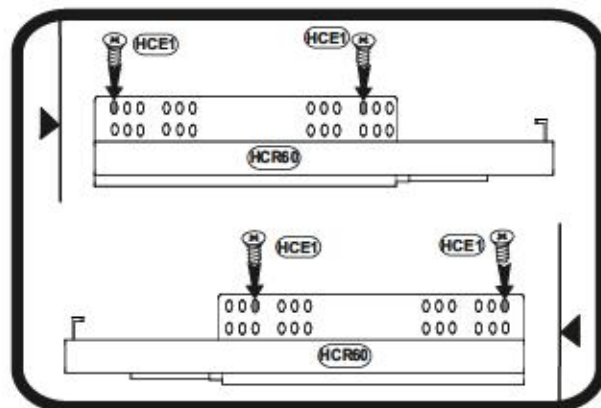
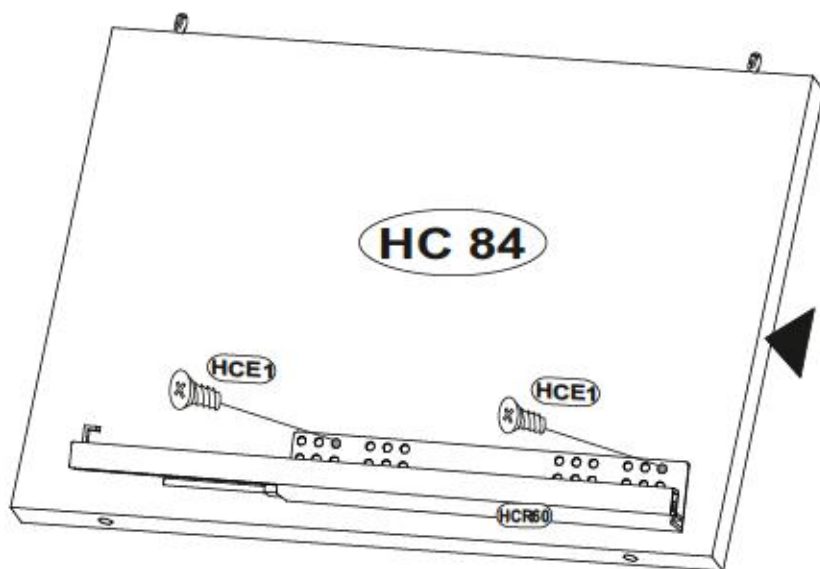
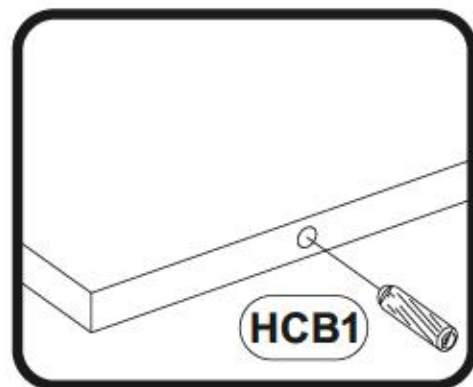
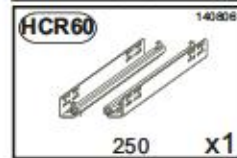
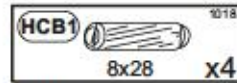
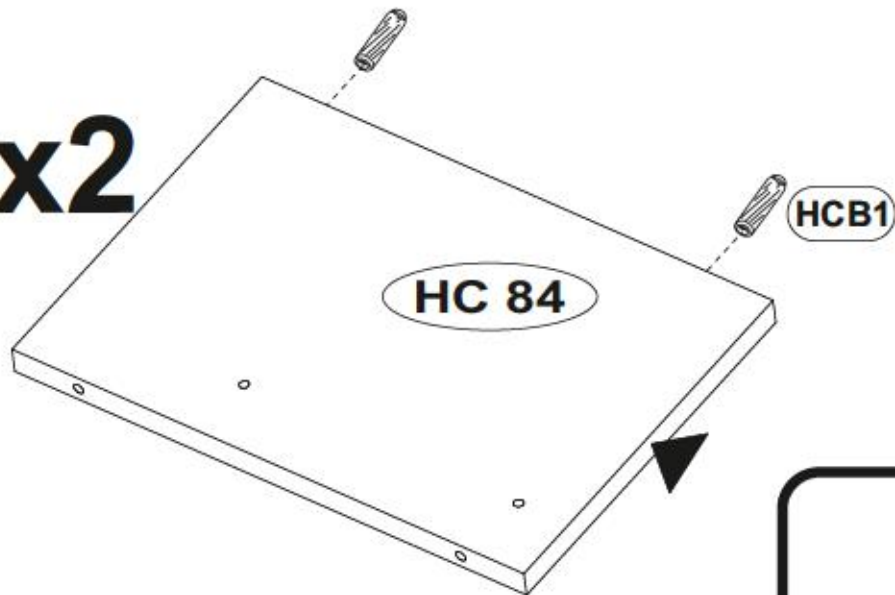

x2

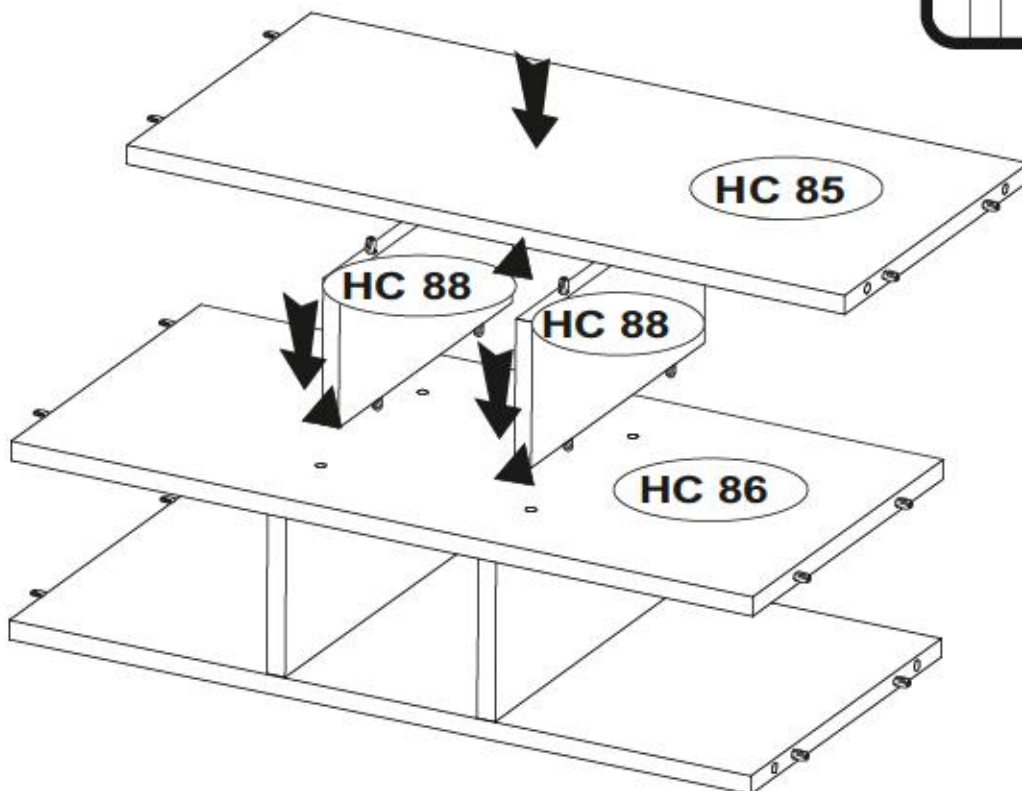
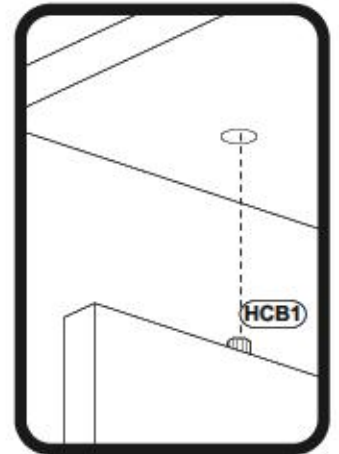
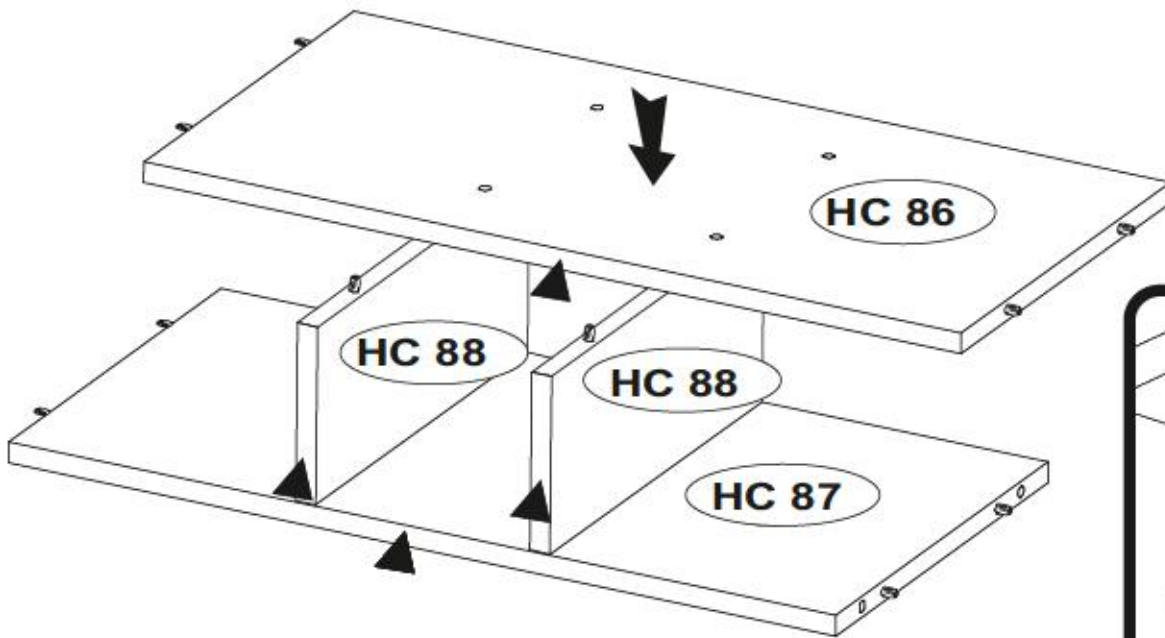
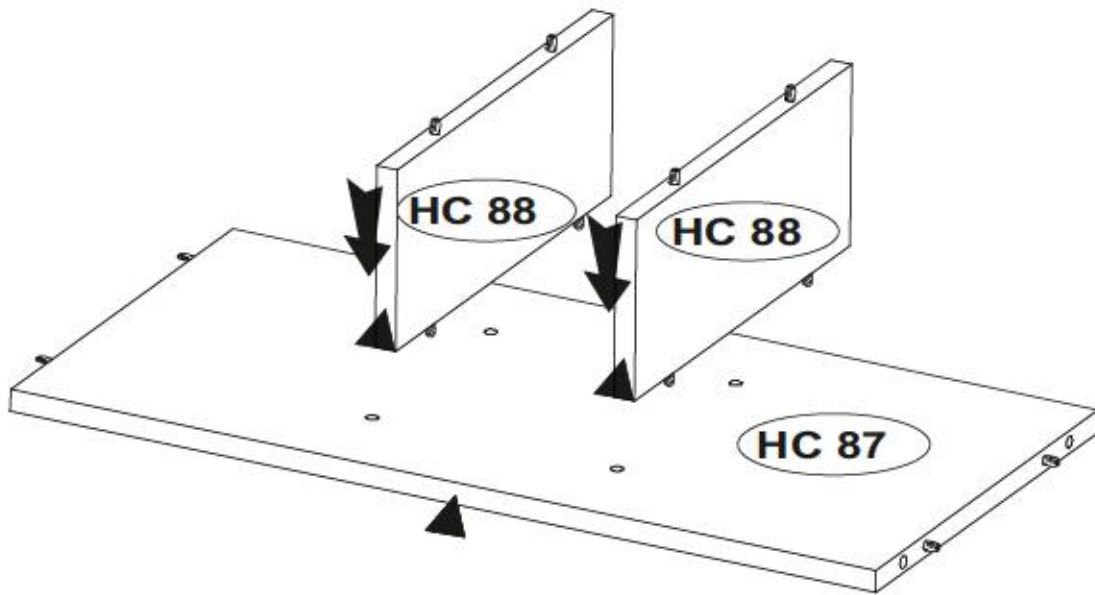

13

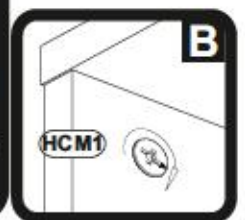
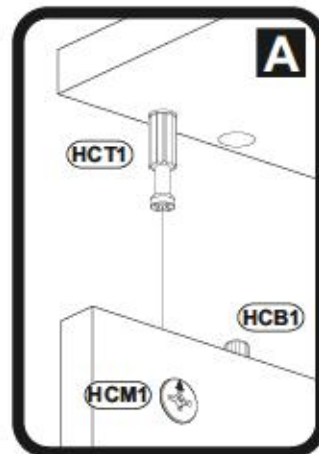
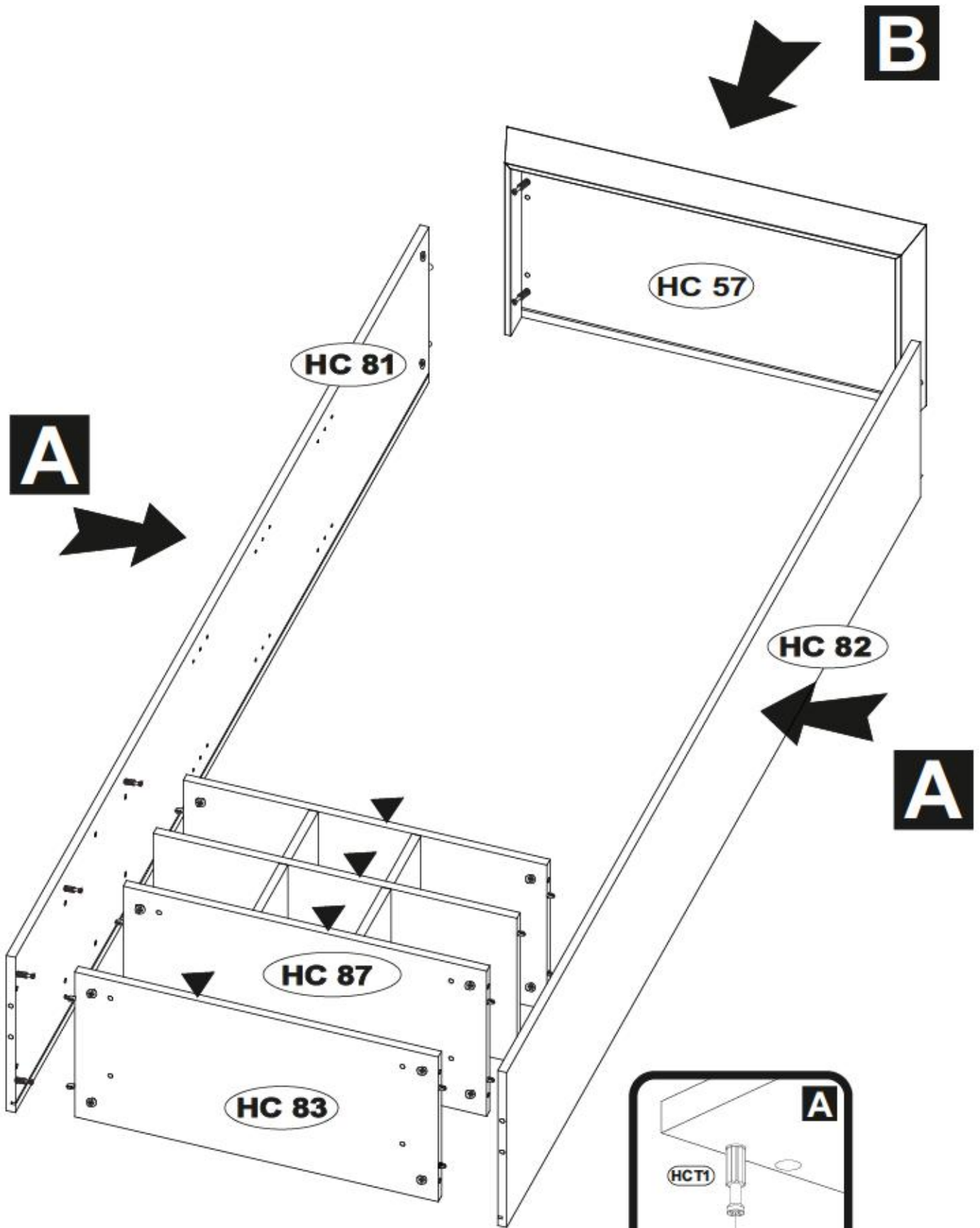



HCS3		1011
	3,5x13	x24
HCK1		1354
	7x50	x4

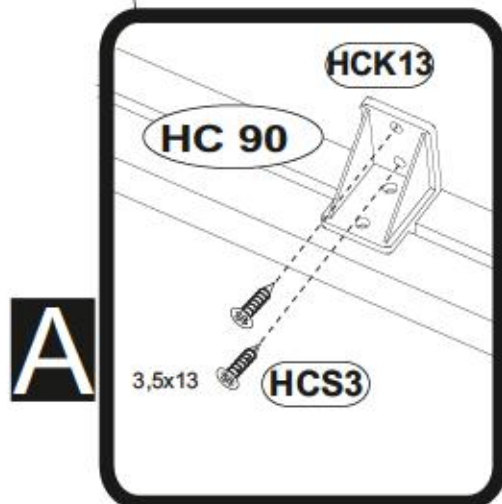
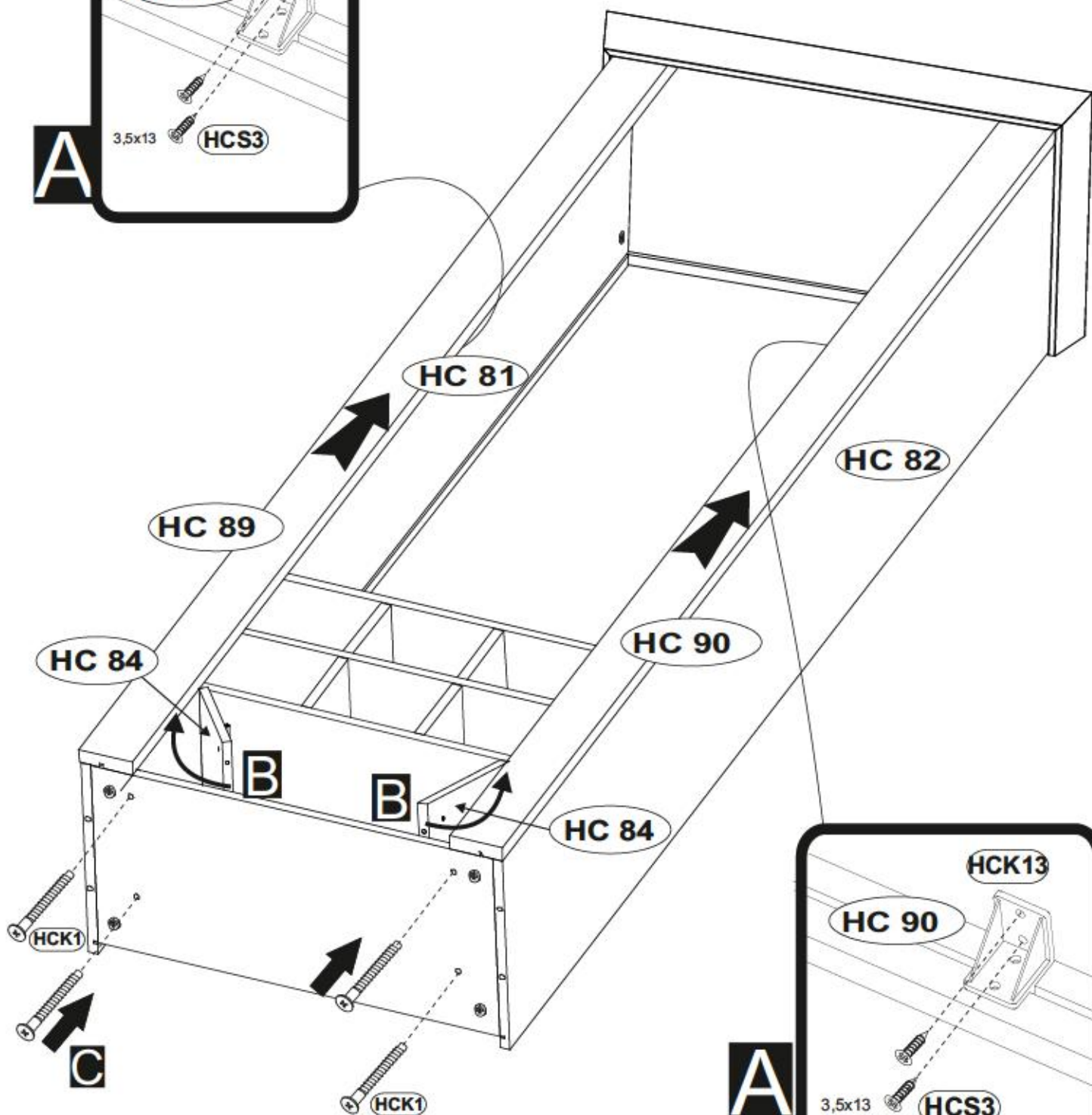
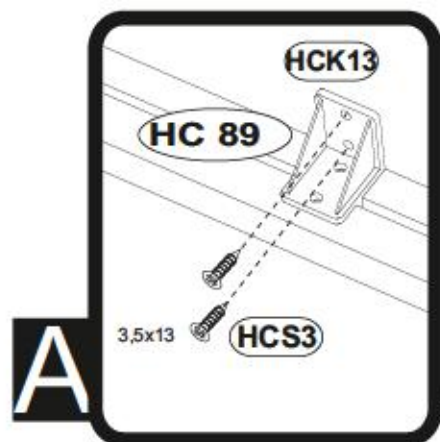

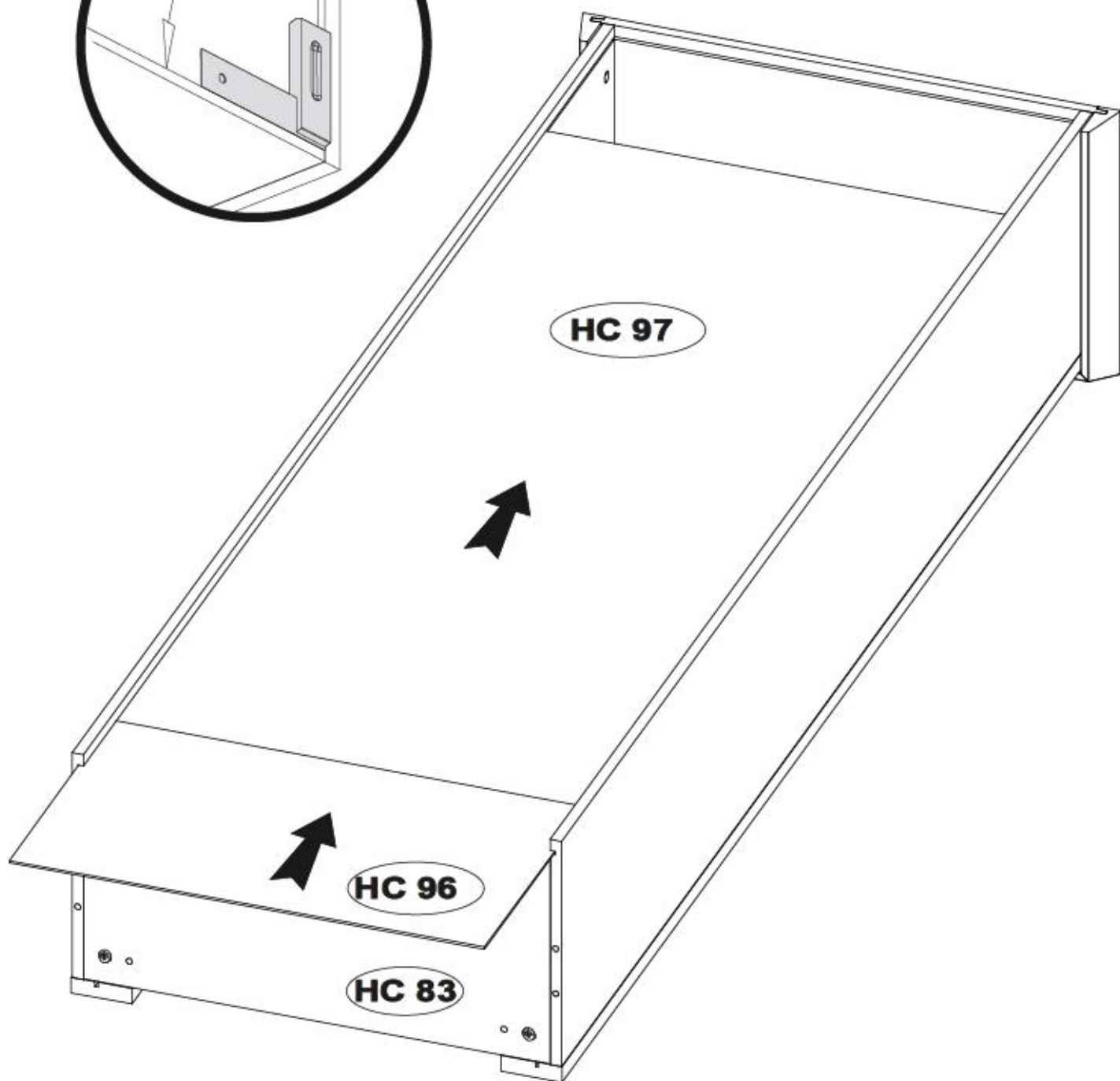
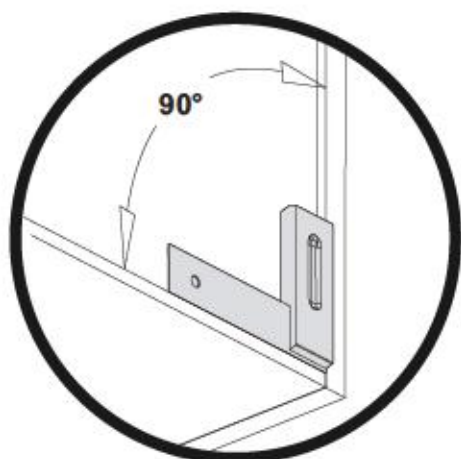

HCS3		1011
	3,5x13	x8



HCJ23		1302
		x14

HCF1		1415
		x4

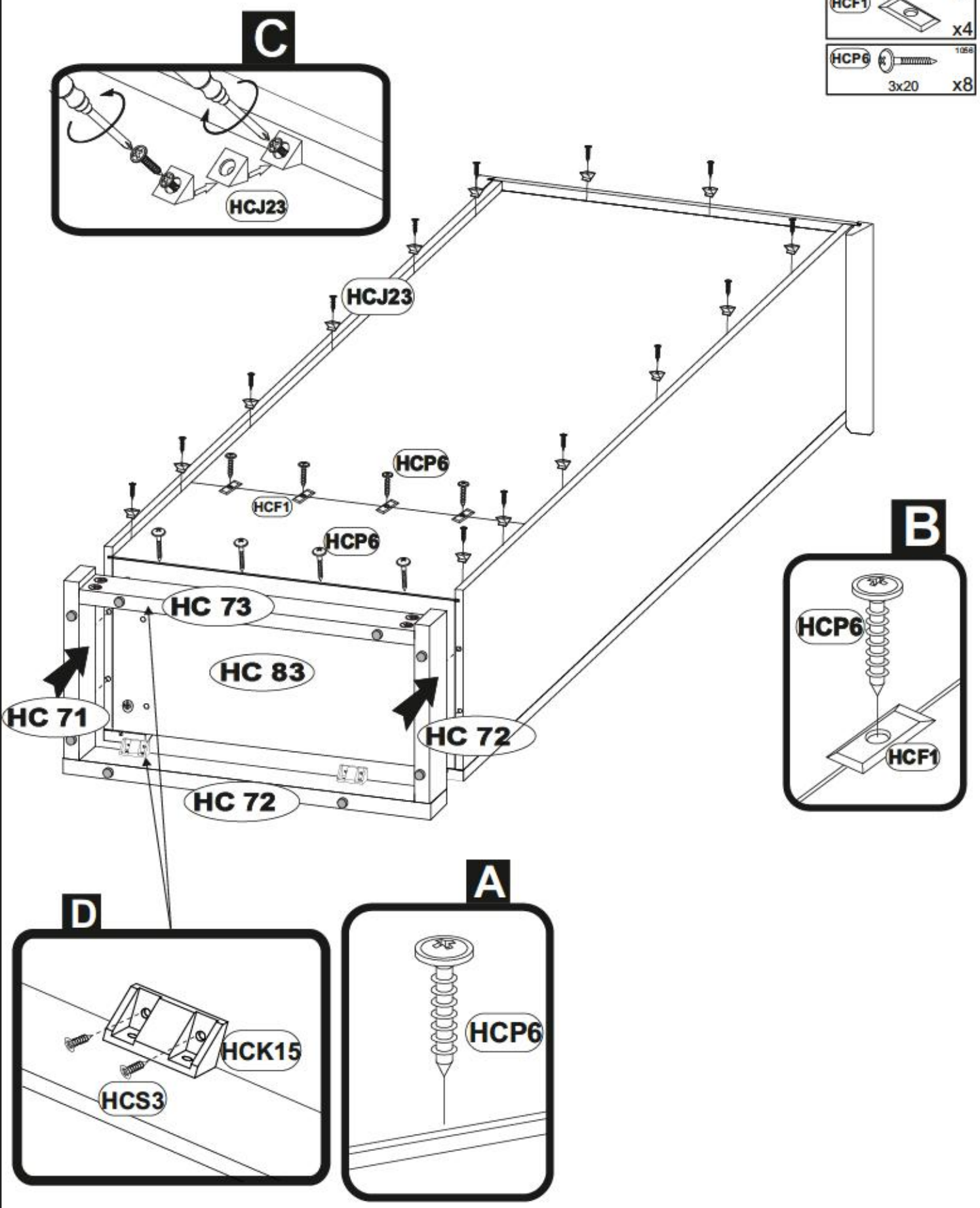
HCP6		1066
	3x20	x8

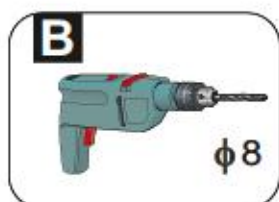
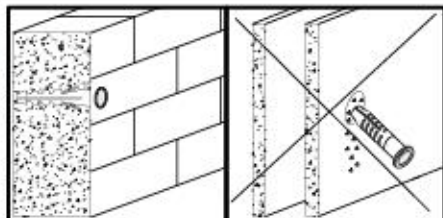



- HCS3**  1011
3,5x13 x4
- HCW1**  1289
x12
- HCJ11**  1287
x1

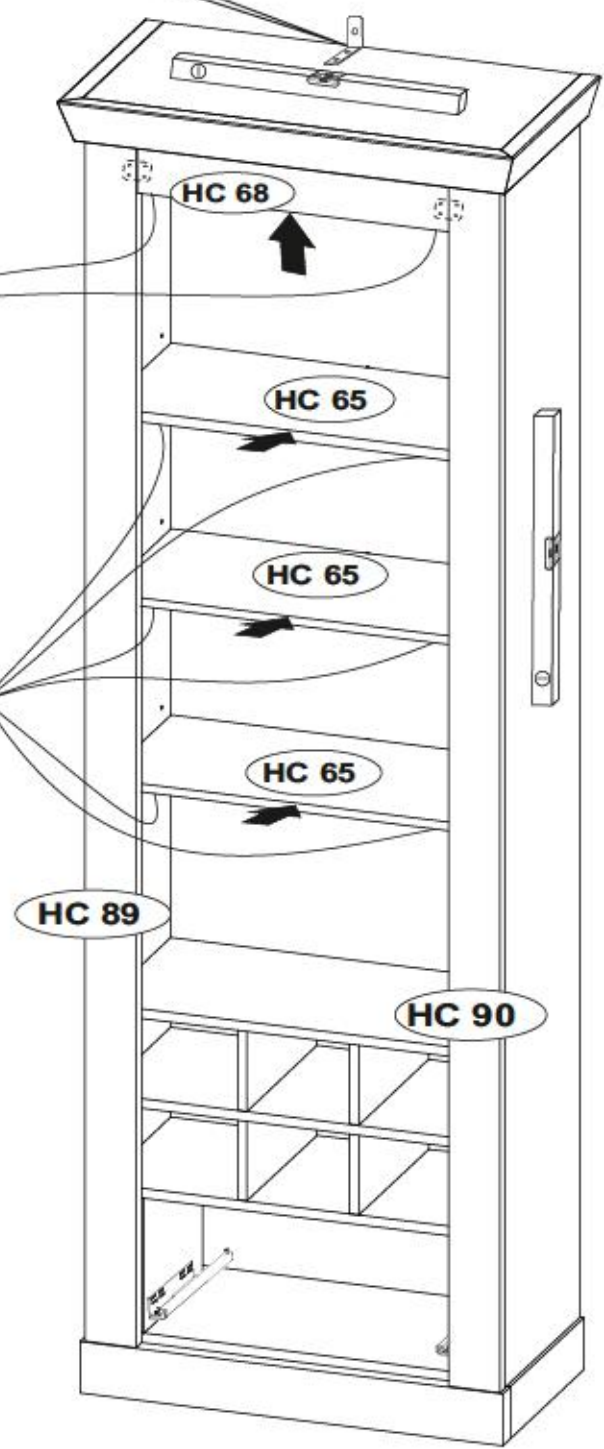
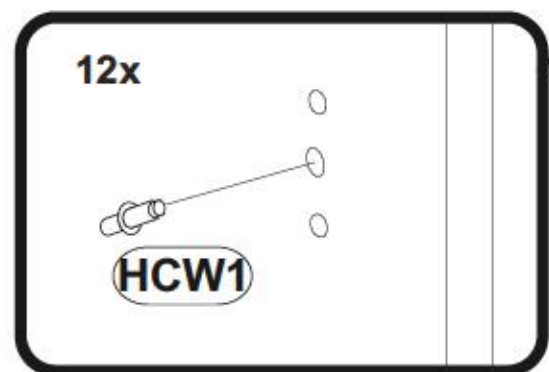
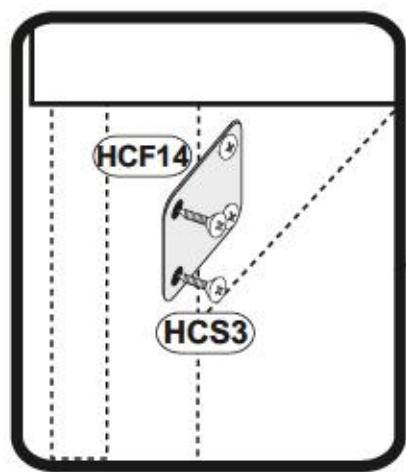
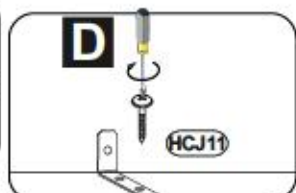
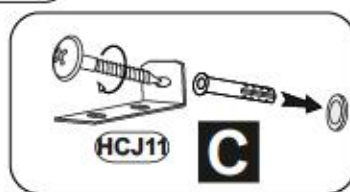
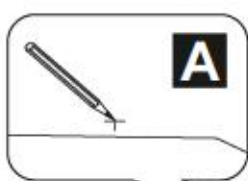

19

Option L



HC 80

HC 90

HC 89

HC 93

HC 93

HC 94

HC 47

- HCA4 14410 WPM 4x18 x3
- HCUC160 14400 1 x1
- HCC5 120090 1 x1
- HCP2 1144 3.6x13 1 x1
- HCC6 14411 4x20 x8
- HCUC1 14401 1 x1

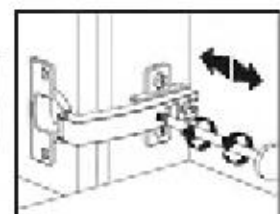
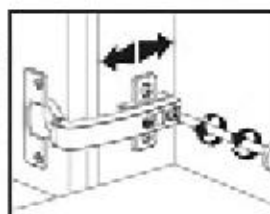
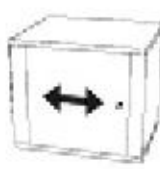
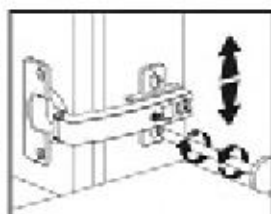
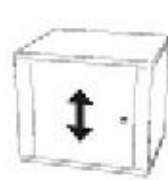
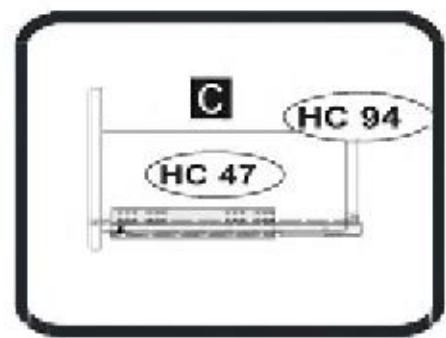
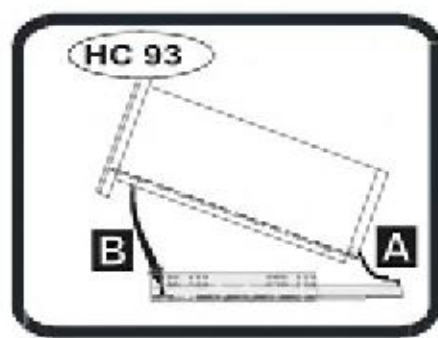
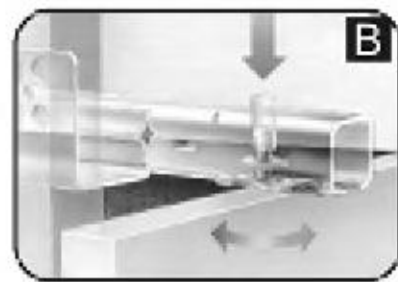
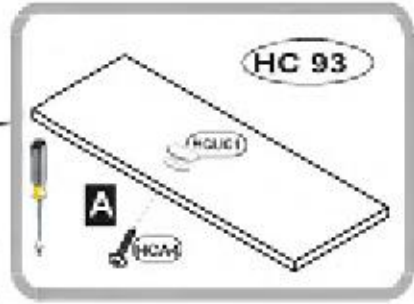
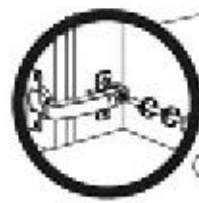
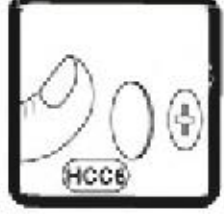
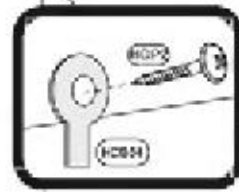
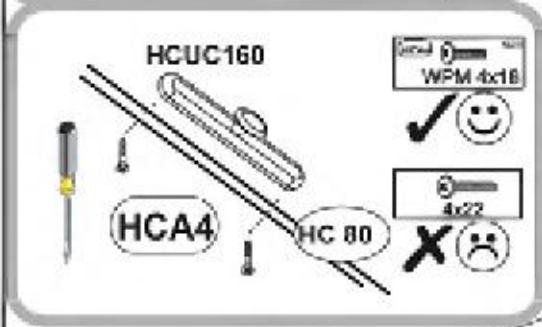



- HCA4** 14418
WPM 4x18 x3
- HCUC160** 14205
1 x1
- HCC5** 120090
1 x1
- HCP2** 1144
3.6x13 x1
- HCC6** 142115
4x20 x8
- HCUC1** 142071
1 x1

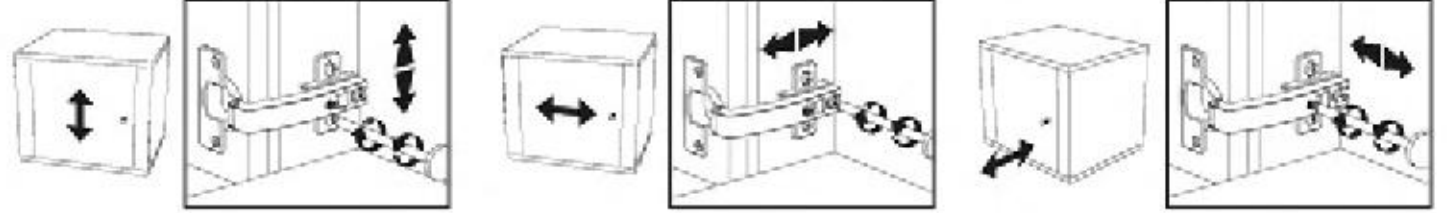
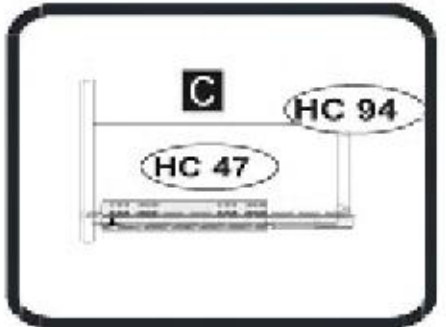
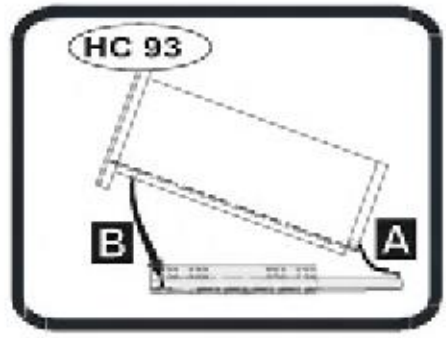
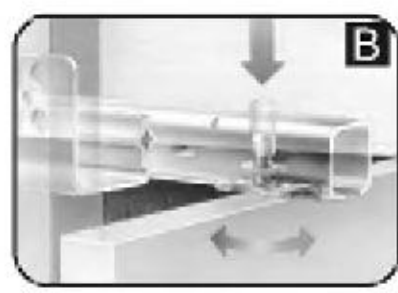
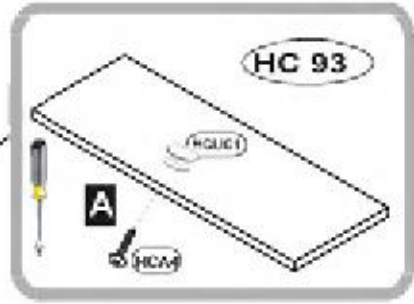
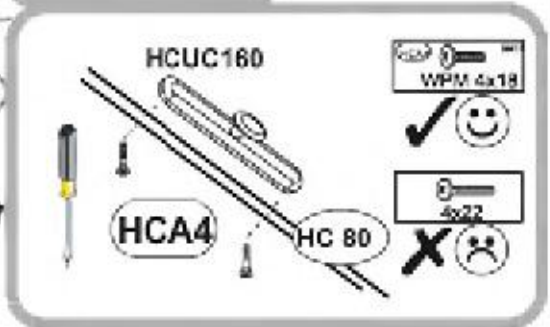
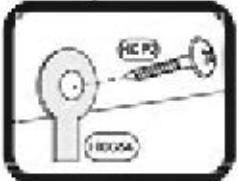
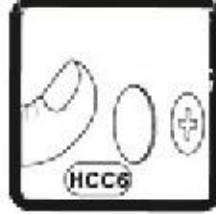

RAVENNA 23

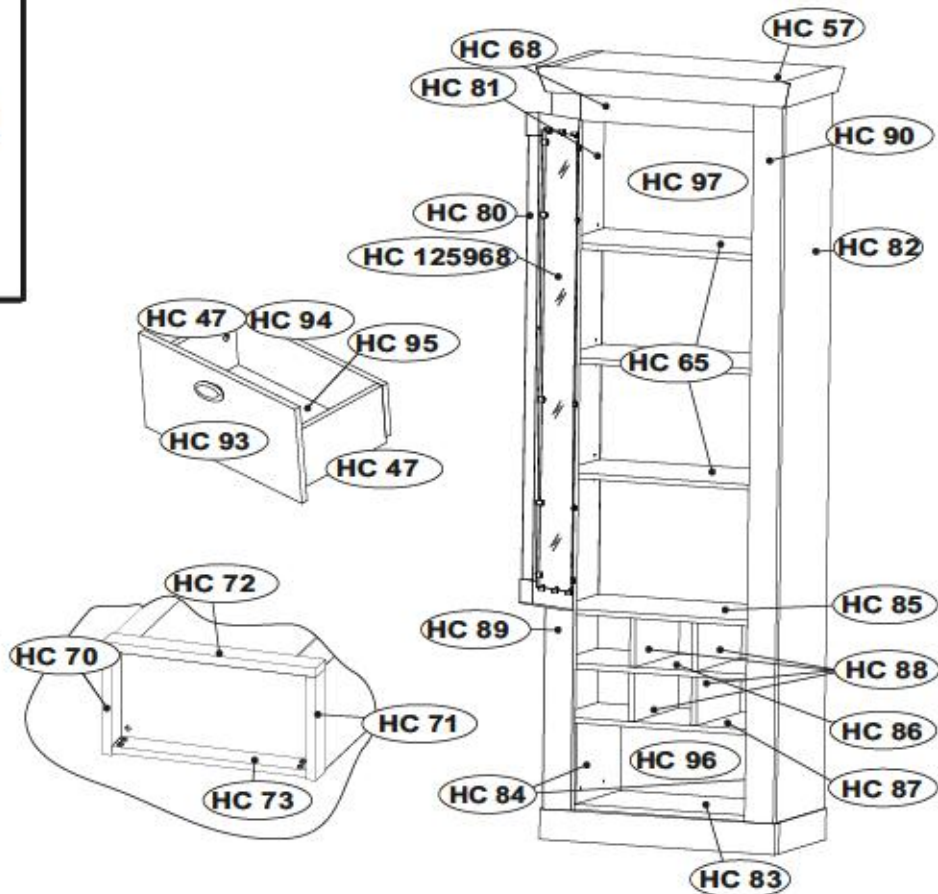

D Unser Dienstleistungs-Service für Sie
Sollte Ihnen ein Beschädigtes Teil, können Sie diese Servicekarte direkt an die untenstehende Adresse mailen. Wir können es sendend nur Beschädigtes auf diesem Wege verschicken. Sollten Sie eine andere Beschreibung an Ihrem Möbelstück haben, so senden sie auch bitte direkt an Ihr Möbelhaus.

GB Our direct order service for filling
If a filling part is missing, you can e-mail this service card directly to the address below. However, we can only send filling parts in this way. If you have any other cause for complaint concerning your item of furniture, please contact your furniture store directly.

CZ Naše přírodní služby pro kování
Chybí-li vám nějaký díl z kování, můžete tuto service kartu odeslat e-mailem přímo na naše ústřednou adresu. Touto cestou však můžeme zaslat jen díly kování. Pokud máte nějakou jinou příčinu stížnosti, obraťte se přímo na svého prodejce nábytku.

F Bien étudier la notice de montage
Si l'un de vos meubles a une fissure, veuillez envoyer directement la présente carte de service à l'adresse e-mail indiquée ci-dessous. Cependant, ceci nous permet uniquement d'envoyer des ferrures. Pour tout autre type de réclamation concernant votre meuble, veuillez contacter directement votre magasin d'ameublement.

I Il nostro servizio clienti per il vostro negozio
Qualora Vi dovesse mancare un pezzo di fissaggio, all'ora Vi preghiamo di inviarci questo card di servizio direttamente all'indirizzo e-mail sottostante. Possiamo inviare i pezzi di fissaggio solamente per mezzo di questo procedimento. Qualora dovete avere qualche altra reclamazione in merito al mobile, allora Vi preghiamo di rivolgerVi direttamente al Vostro Negozio di mobili.

BG Нашите директно услуги за обнова
Ако липсват части от ковалята, попълнете настоящата сервисна карта и не я изпращайте по-малък адрес, защото по-голям. По този начин може да доставим само заповедни елементи от обнова. Ако установите други дефекти по мебелите, се съветваме да се обърнете към вашия магазин за мебели, от който сте закупили стоките.

NL Onze directie service voor klinker onderdelen
Wanneer er een onderdeel ontbreekt, kunt u deze servicekaart direct aan ons sturen en e-mailadres gebruiken. Wij kunnen langzame weg alleen alleen beschadigde onderdelen, slechts u een ander probleem aan uw meubel hebben, verzeken wij u contact op te nemen met u meubel dealer.

PL Nasze bezpośrednie usługi dla klientów
Jeżeli brakuje części krawędziowej do montażu, prosimy o przesłanie nam niniejszej karty serwisowej na nasz podany adres e-mailowy. W ten sposób możemy przelać do Państwa tylko krawędziowe części. W przypadku innych niekwalifikujących się mebli, prosimy zgłosić się do salonu meblowego, w którym zostały dokonane zakupy.

HR Servis za obnova
U slučaju da nedostaje neki od dijelova molimo vas da nas dođe obavijestiti mail adresom podjelite ovaj service karticu. Na ovaj način mogu vam dostaviti samo klinker. U slučaju da imate dodatne prigovore molimo vas kontaktirati našega prodavača da se obratite izravno trgovini namještaja gdje je isti kupljen.

HU Közvetlen szolgáltatás a csatlakozásokért
Ha hiányzik egy csatlakozó, e-mail címen küldje el nekünk ezt a szolgó kártyát. Csak a csatlakozókat tudjuk küldeni. Ha van egyéb panasz a meblével kapcsolatban, kérjük forduljon a bolti eladóhoz.

SK Naše priame služby pre kovanie
Ak by Vám chýbala niekedy časť kování, môžete poslať túto service kartu priamo na náš e-mail adresou uvedenú nižšie. Cieľom kování je iba kovanie. Ak by ste mali inú reklamáciu ohľadom vášho nábytku, obráťte sa priamo na Vašu predajňu nábytku.

SLO Naše direktno službovanje preko kartice
Če vam manjka kakikoli delov, lahko to posredujete kartico polnjeno po e-pošti direktno na spodnji naslov. Po tej poti vam lahko pošljemo samo obovke. Če želite reklamirati karkoli drug del pohištva, se obrnite neposredno na vašo trgovino pohištva.

RO Serviciul nostru direct pentru kování
În cazul în care vă lipsește o piesă de kování, puteți să trimiteți direct acest card de service prin e-mail la adresa de mai jos. Noi nu putem accepta pluse decât kování de către pe adresa de mai jos. Dacă aveți o altă reclamație referitoare la piesa de mobilier, atunci vă rugăm să vă adresați direct la magazinul dvs. de mobilier.

RUS Наш прямой сервис для поставок фурнитуры
Если вы заметили, что отсутствует какая-либо часть крепежа фурнитуры, вы можете отправить сервисную карту по факсу на указанный ниже адрес электронной почты. Мы сможем доставить только фурнитуру. Если же у вас имеются иные претензии относительно приобретенной мебели, пожалуйста, обращайтесь непосредственно в магазин, осуществляющий продажу.

S Váš priamotný servis pre kovanie
Otvor du sakeer an beschadigd item du stuurde de servicekaart direct tãl e-mailadres aan ons adres. Alleen klinker kan worden verzonden via deze manier. Indien u andere klachten hebt over uw meubel, wordt u verzocht u te wenden tot de winkel waar u het meubel hebt aangekocht.

ES Nuestro servicio directo para kování
Si le falta algún accesorio, puede enviar este tarjeta de servicio directamente a la siguiente dirección. No obstante, por este método solo podemos enviar accesorios. Si tiene alguna otra objeción sobre su mueble, consulte directamente con su mueblería.

TR Doğrudan servis için aksesuarlar için
Bir dozent ekleme ya da servisi için doğrudan siparişinizi bula adresine doğrudan mail yoluyla biliniz. Sadece bu yolla dozentin gönderilir. Mobilyanızla ilgili diğer problemler için doğrudan mobilya satıcınıza danışın.

HC 47	x2	237	140	15	2/2	HC 84	x2	209	250	15	2/2
HC 57	x1	702	372	65	1/2	HC 85	x1	611	299	15	1/2
HC 65	x3	610	273	22	1/2	HC 86	x1	611	299	15	1/2
HC 68	x1	483	124	18	2/2	HC 87	x1	611	299	15	1/2
HC 70	x1	317	80	28	1/2	HC 88	x4	124	298	15	2/2
HC 71	x1	317	80	28	1/2	HC 89	x1	1911	80	22	2/2
HC 72	x1	656	80	28	1/2	HC 90	x1	1911	80	22	2/2
HC 73	x1	598	80	28	1/2	HC 93	x1	477	230	15	2/2
HC 80	x1	1279	477	18	2/2	HC 94	x1	466	126	15	2/2
HC 81	x1	1911	320	15	2/2	HC 95	x1	447	258	2.5	2/2
HC 82	x1	1911	320	15	2/2	HC 96	x1	368	623	2.5	2/2
HC 83	x1	611	299	15	1/2	HC 97	x1	1546	623	2.5	2/2
HC 125968	x1	1189	386	4	2/2						

RAVENNA 23

D Unser Dienstservice für Beschädigte
 Sollte Ihnen ein Beschädigtes fehlen, können Sie diese Servicekarte direkt an die untenstehende Adresse mailen. Wir können allerdings nur Beschädigte auf diesem Wege versenden. Sollten Sie eine andere Sendung an Ihre Möbelstücke haben, so wenden sie sich bitte direkt an Ihre Möbelhaus.

GB Our direct order service for fitting
 If a fitting part is missing, you can e-mail this service card directly to the address below. However, we can only send fitting parts in this way. If you have any other cause for complaint concerning your item of furniture, please contact your furniture store directly.

CZ Náš primární službu pro kování
 Pokud Vám chybí nějaký díl z kování, můžete tuto službu kartou adresát e-mailem přímo na náš e-mail adresou dle níže. Tuto službu však můžeme poskytnout jen díky kování. Pokud byste měli nějaký jiný problém, obraťte se přímo na svého prodejce nábytku.

F Bien servi et la notice de montage
 Si vous manquez une pièce, veuillez en voyer directement le présent carte servi et l'adresse e-mail indiquée ci-dessous. Cependant, ceci nous permet uniquement d'envoyer des fixatures. Pour tout autre type de réclamation concernant soit le meuble, veuillez contacter directement votre magasin de meubles.

I Il nostro servizio diretto per il cliente delle forniture
 Qualora Vi dovessero mancare un pezzo di fissaggio, allora Vi preghiamo di inviare questa carta di servizio e-mail direttamente all'indirizzo sotto allegato. Possiamo inviare i pezzi di fissaggio solamente per mezzo di questo procedimento. Qualora dovete avere qualche altra domanda in merito al mobile, allora Vi preghiamo di rivolgerVi direttamente al Vostro Negozio di mobili.

BG Неволно доставени части за обнова
 Ако имате част от мебелите, които не са доставени, моля да ни пишете на е-пощата на адреса, който е посочен по-долу. По този начин можем да доставим само необходимите компоненти от обзавеждането. Ако искате да решите друг проблем по мебелите, ще съветваме да се свържете със мебелите в магазина, от който сте закупили мебелите.

NL Onze directservice voor losse onderdelen
 Wanneer er een onderdeel ontbreekt, kunt u deze servicekaart direct aan ons toezenden e-mailadres sturen. Wij kunnen langzame verzending van losse onderdelen verzenden. Maar niet voor andere problemen aan uw meubel hebben, verzenden wij u contact op te nemen met uw meubeldealer.

PL Nasz bezpośredni serwis części montażowych
 Jeżeli brakuje części koniecznych do montażu, prosimy o przesłanie nam niniejszej karty serwisowej na nasz adres e-mailowy. W ten sposób możemy przesłać. Ponieważ tylko brakujące części. W przypadku innych reklamacji dotyczących mebla, prosimy zgłaszać je do naszego meblowego, w którym został dokonany zakup.

HR Služba za otklonu
 U slučaju da nedostaje neki od dijelova meblima, važno je da ih najbrže pošaljemo mailom direktno na naš e-mailni adres. Na ovaj način mogu se dostaviti samo dijelovi. U slučaju da imate do daljine prigovore vezane uz komad namještaja, molimo vas da se obratite izvorno trgovcu namještaja gdje je isti kupljen.

HU Díjazáró szolgálatunk a kiegészítőkért
 Ha hiányzik egy részlet, azt a kiegészítőkért e-mail címen keresztül küldje el nekünk. Azonban csak a hiányzó részeket tudjuk így kiküldeni. Amennyiben más problémát szeretne felvetni a meubelével kapcsolatban, forduljon közvetlenül a bolti képviselőjéhez.

SK Náš primárny servis pre čisti kováčik
 Ak by Vám chýbala niekajá časť kováčika, môžete poslať túto službu kartou adresát e-mailem priamo na náš e-mail adresu. Tuto službu však môžeme poskytnúť iba v prípade kováčika. Ak by ste mali inú reklamáciu ohľadom Vášho nábytku, obráťte sa priamo na Vašu predajňu nábytku.

SLO Náš direktno kúpitelna storitev za obnove
 Če vam manjka kakšna komponenta, lahko to sporočite kar direktno po e-pošti dle našega e-mailnega naslova. Po tej poti vam lahko pošljemo samo komponente. Če želite rešiti kakšen drug del problema, se obrnite neposredno na vašo trgovino pohištva.

RO Serviciul nostru direct pentru furnituri
 În cazul în care vă lipsește o piesă de furnitură, vă rugăm să trimiteți direct această card de service prin e-mail la adresa de mai jos. Noi nu putem trimite decât piesele de furnitură de înlocuire prin această cale. Dacă aveți o altă reclamație referitoare la piesa de mobilier, atunci vă rugăm să vă adresați direct la magazinul din care ați cumpărat.

RUS Прямой сервис доставки фурнитуры
 Если оказалось, что Вам не хватает той или иной детали фурнитуры, Вы можете отправить сервисную карту по факсу непосредственно на наш прямой адрес электронной почты. Однако, только детали мы можем отправить только по электронной почте. Если же у Вас возникнут иные претензии относительно приобретенной мебели, пожалуйста, обращайтесь непосредственно в магазин, где была куплена.

S Unser direktservice für beschädigte
 Om du saknar en belysning del kan du skicka detta servicekort direkt till e-postadressen som anges nedan. Tänk på att detta är den enda möjligheten att skicka belysning delar till dig. Om du vill reklamera din möbel av en annan anledning måste du kontakta ditt möbelhus direkt.

ES Nuestro servicio de envío para accesorios
 Si le falta algún accesorio, puede enviarnos este tarjeta de reclamación a la siguiente dirección. No obstante, por este medio solo podemos enviar accesorios. Si tiene alguna otra objeción sobre su meuble, consulte directamente con su meblaría.

TR Direktiler için doğrudan servis kartı
 Bir ürünün bir aksesuarı bu servise kartını doğrudan aşağıdaki butuna adresine doğrudan mail ya da biletinizle. Sadece bu yolla direktler gönderilebilir. Meblanızda başka şikayetleriniz varsa lütfen doğrudan mobilya satıcınıza danışın.

HCB1		1018	8x28	X...
HCM1		1336		X...
HCT1		1336		X...
HCJ23		1302		X...
HCW1		1289		X...
HCC6		140318	φ20	X...
HCF36		1305		X...
HCA4		14419	WPM 4x18	X...
HCG54		126680		X...
HCP2		1267	3,5x13	X...
HCK1		1354	7x50	X...
HCF14		1021		X...
HCK15		81556		X...

HCG5		1356		X...
HCS11		1073	3x16	X...
HCS3		1011	3,5x13	X...
HCK13		49716		X...
HCUC160		154536		x1
HCJ11		1267		X...
HCP6		1056	3x20	X...
HCE1		1008	ES 6,3x9,5	X...
HCF1		1415		X...
HCD14		23515	H4	X...
HCZ4		49365		X...
HCF44		116795	φ35 90°	X...
HCR60		140806		X...
HCP2		1014	3,5x13	X...
HCUC1		154537		X...

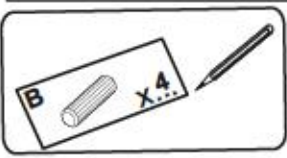

RAVENNA 31

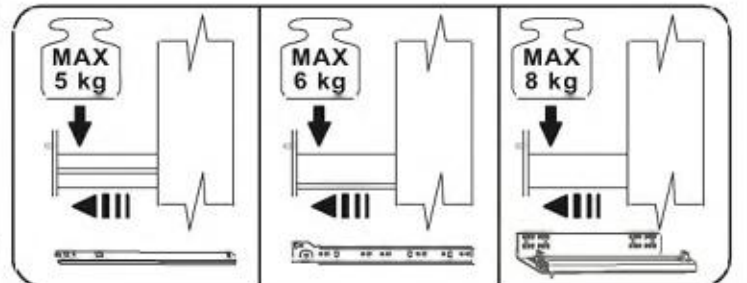
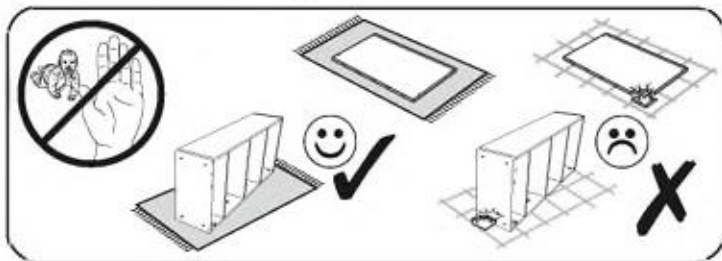
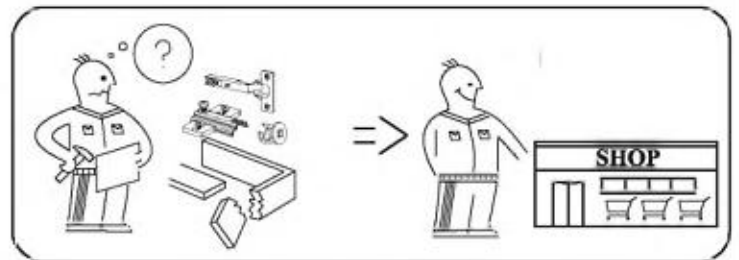
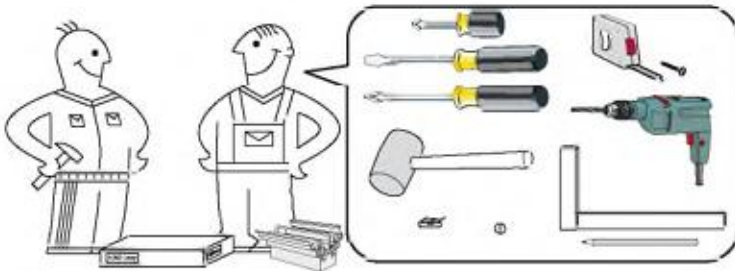
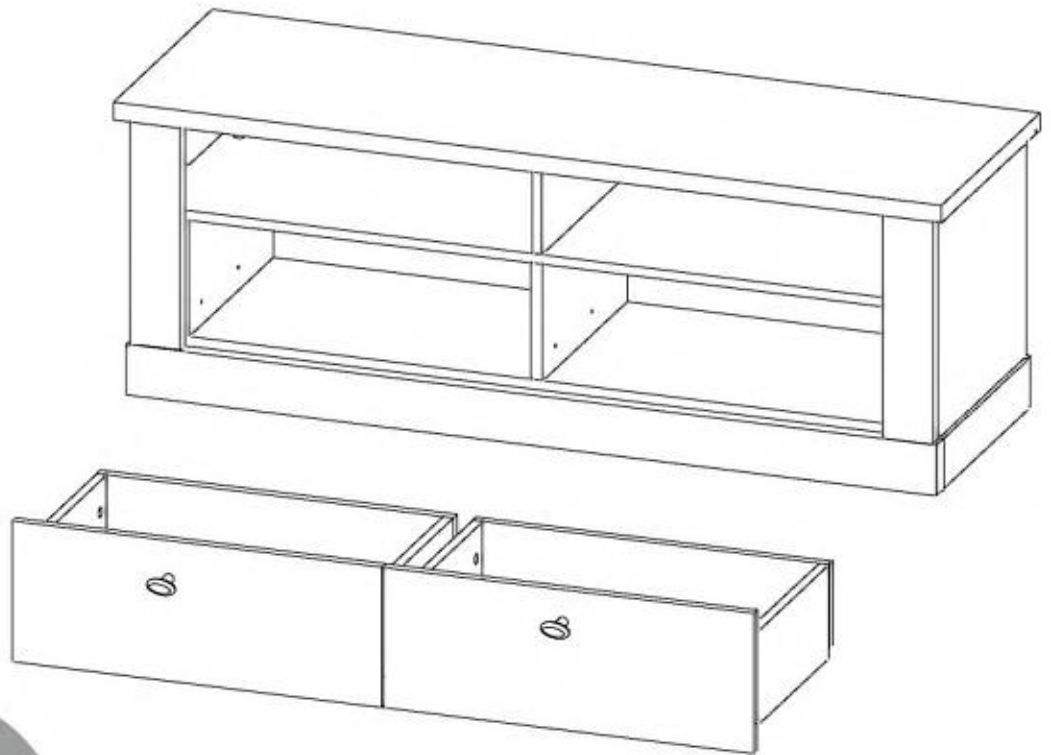

RAVENNA 31

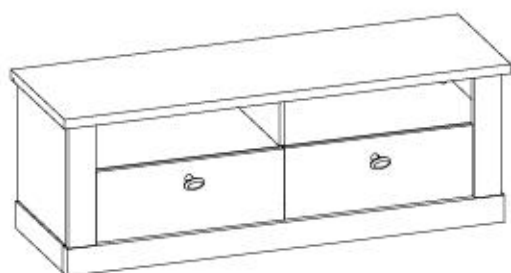

max.



HC 9 HC 8

max.



HC 14

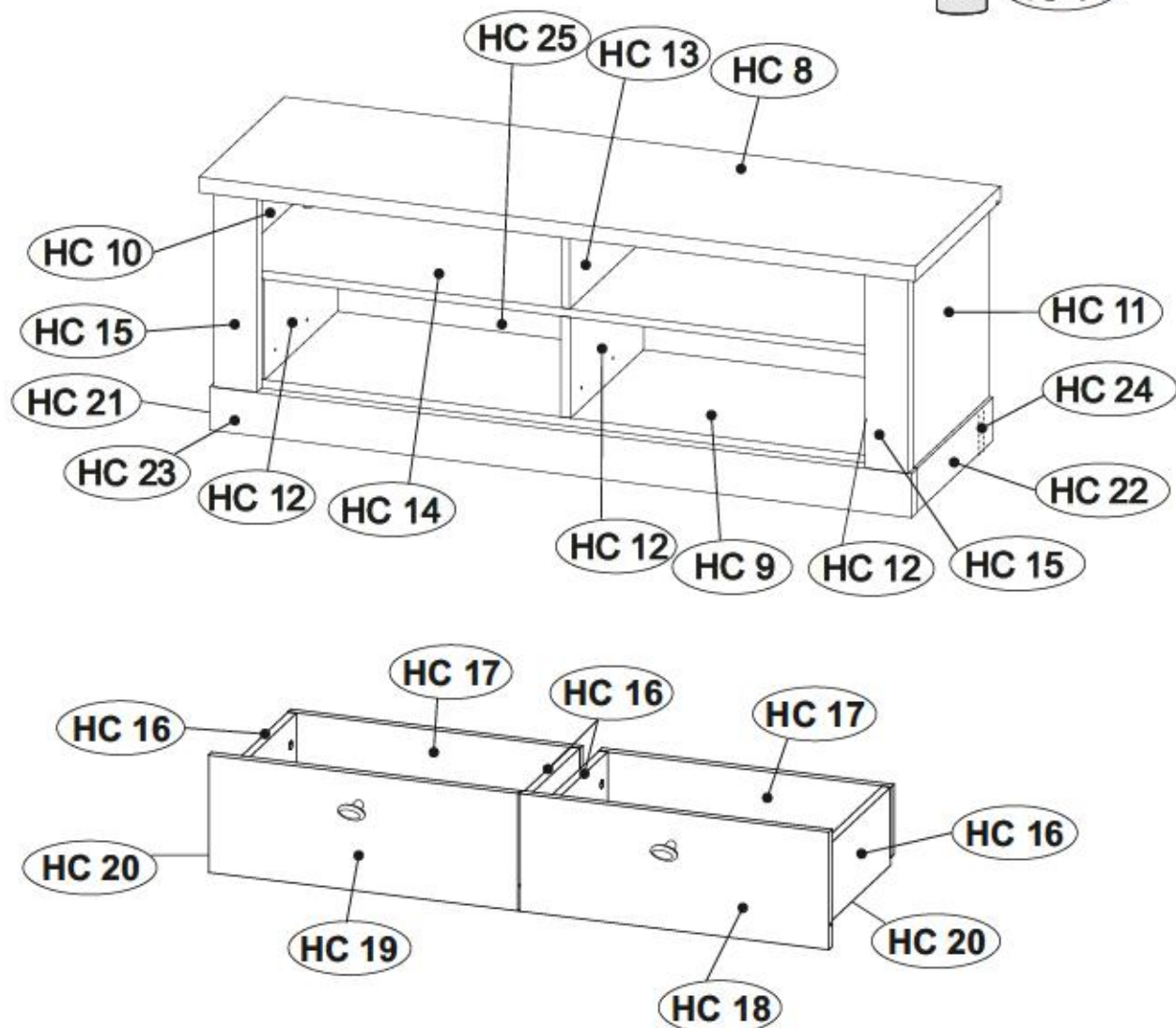

HC 8	x1	1316	431	28	1/1						
HC 9	x1	1244	368	15	1/1						
HC 10	x1	361	389	15	1/1						
HC 11	x1	361	389	15	1/1						
HC 12	x3	185	368	18	1/1	HC 19	x1	553	210	15	1/1
HC 13	x1	146	367	15	1/1	HC 20	x2	515	334	2.5	1/1
HC 14	x1	1244	368	15	1/1	HC 21	x1	386	80	28	1/1
HC 15	x2	361	80	22	1/1	HC 22	x1	386	80	28	1/1
HC 16	x4	313	140	15	1/1	HC 23	x1	1289	80	28	1/1
HC 17	x2	534	126	15	1/1	HC 24	x1	1231	80	28	1/1
HC 18	x1	553	210	15	1/1	HC 25	x1	1256	366	3	1/1

RAVENNA 31

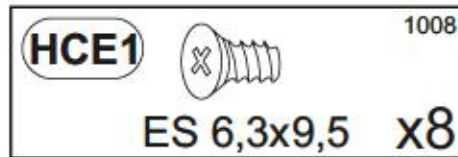
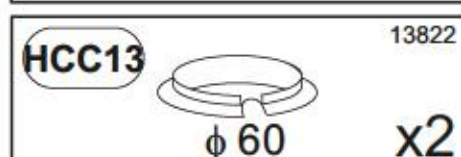
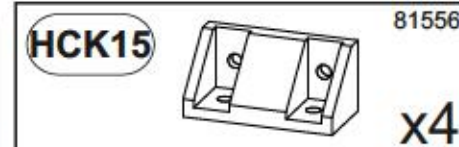
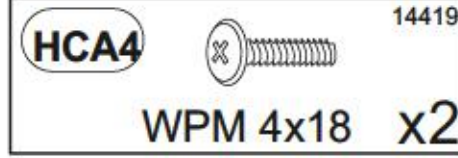
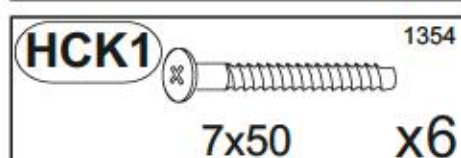
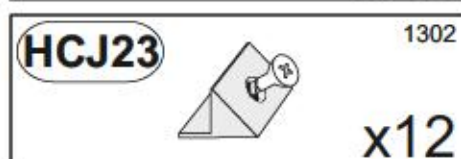
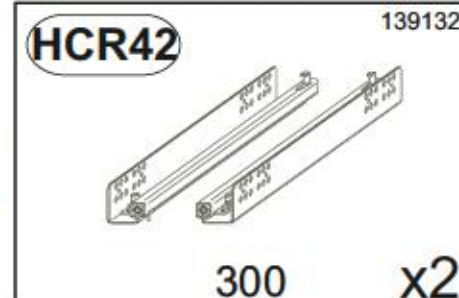
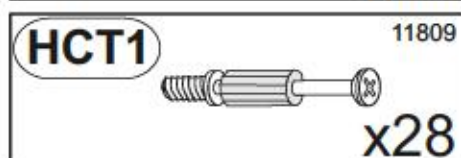
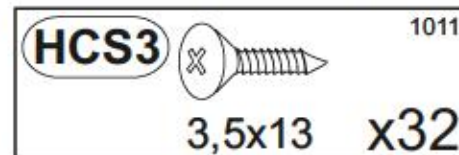
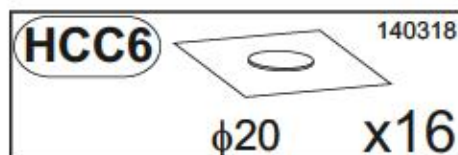
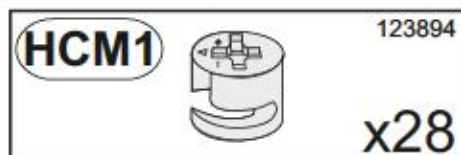
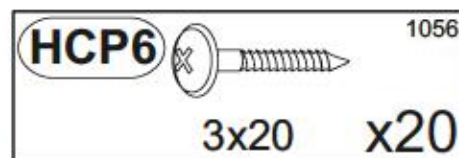
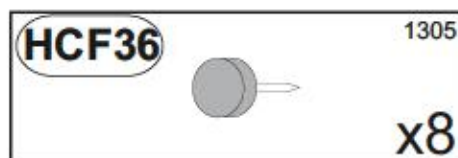
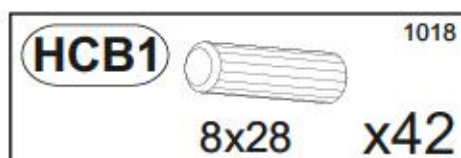

1

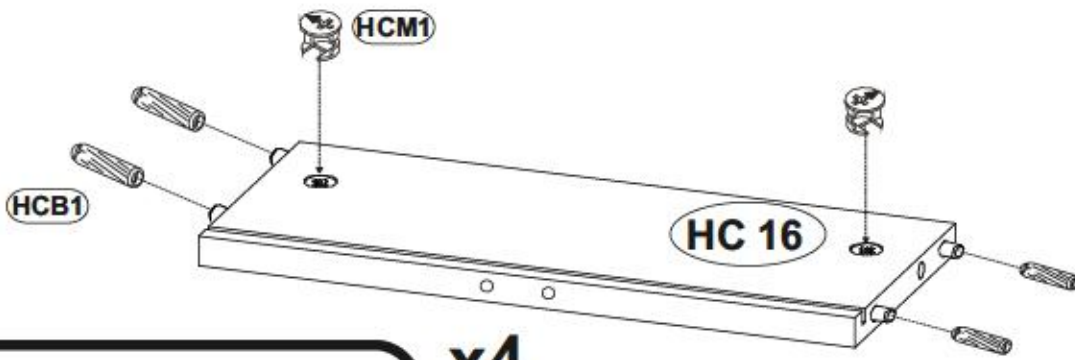

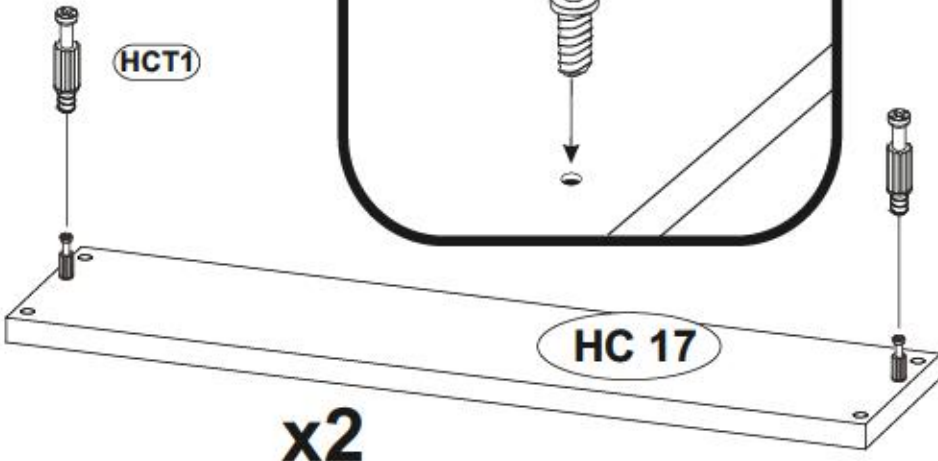
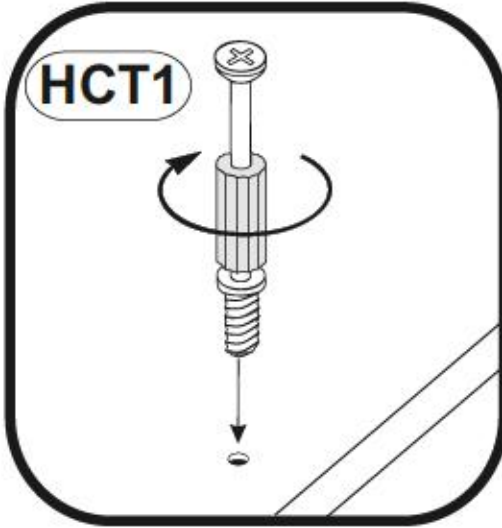
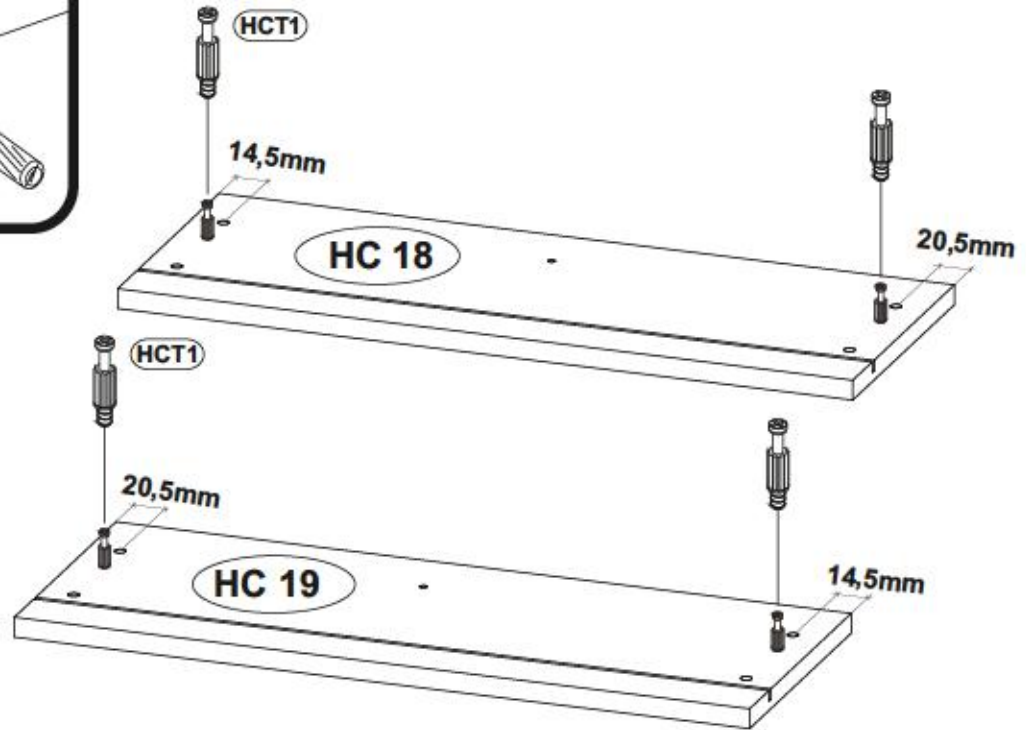
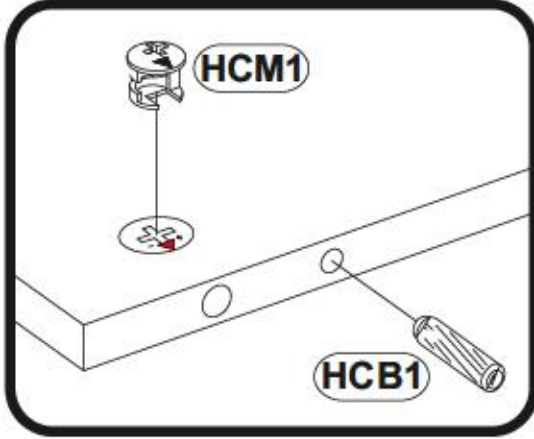

HCB1		1018
	8x28	x16
HCM1		129804
		x8
HCT1		11809
		x8

x4



x2

2

HCJ23		1302
		x4
HCP6		1058
	3x20	x8

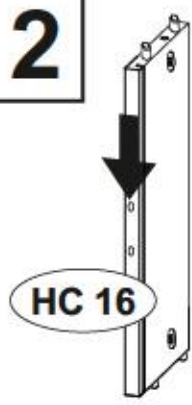

x2

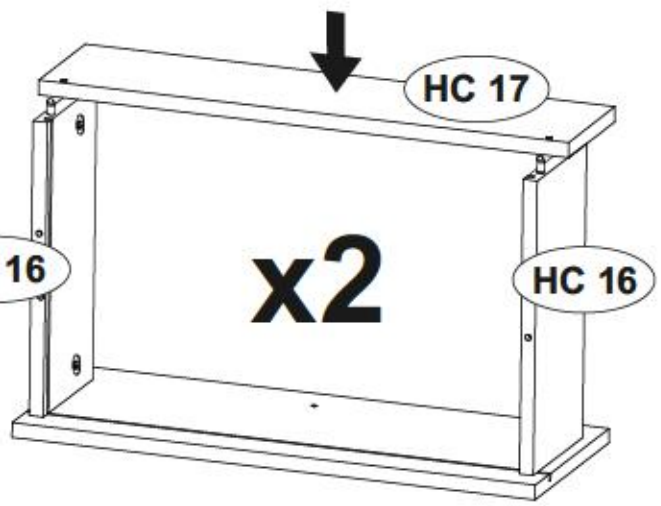
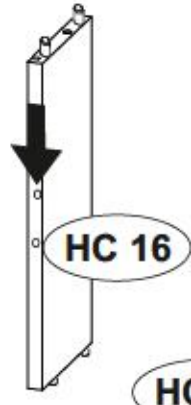

x2

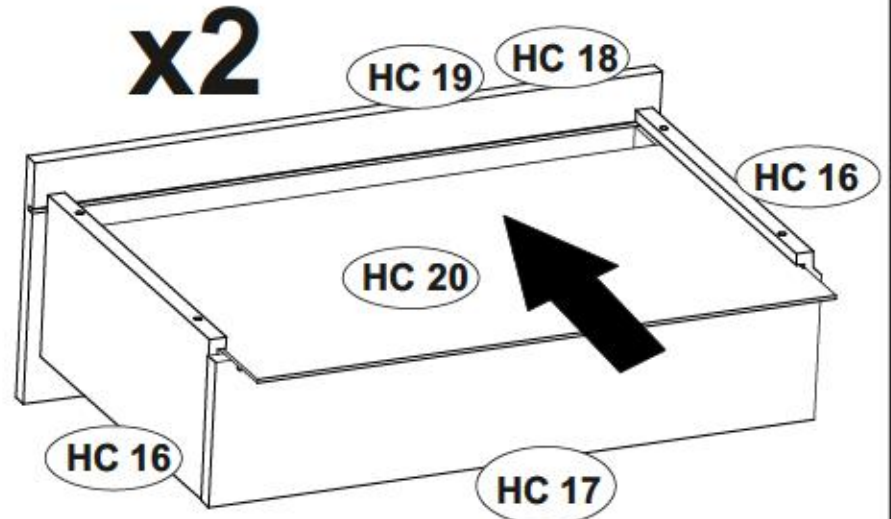
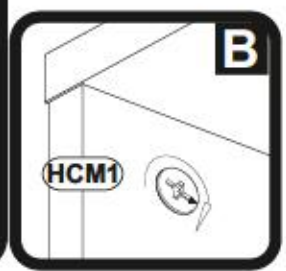
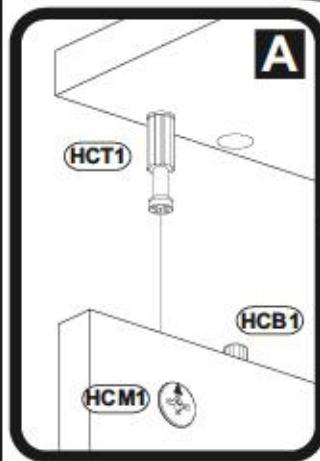
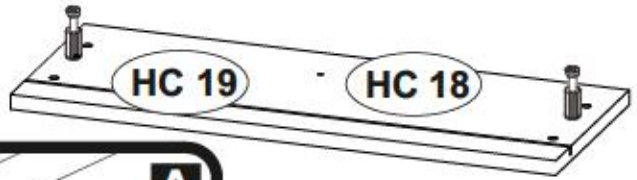

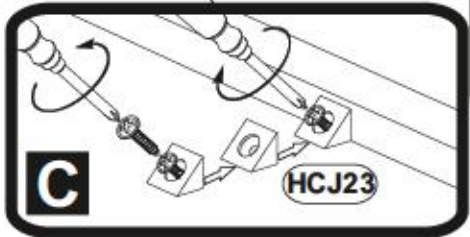
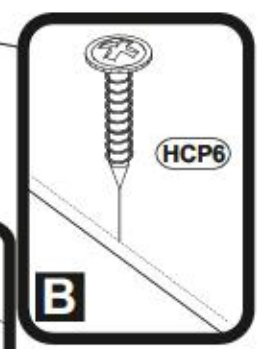
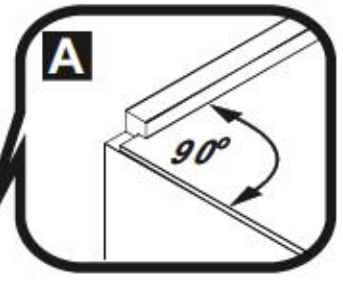
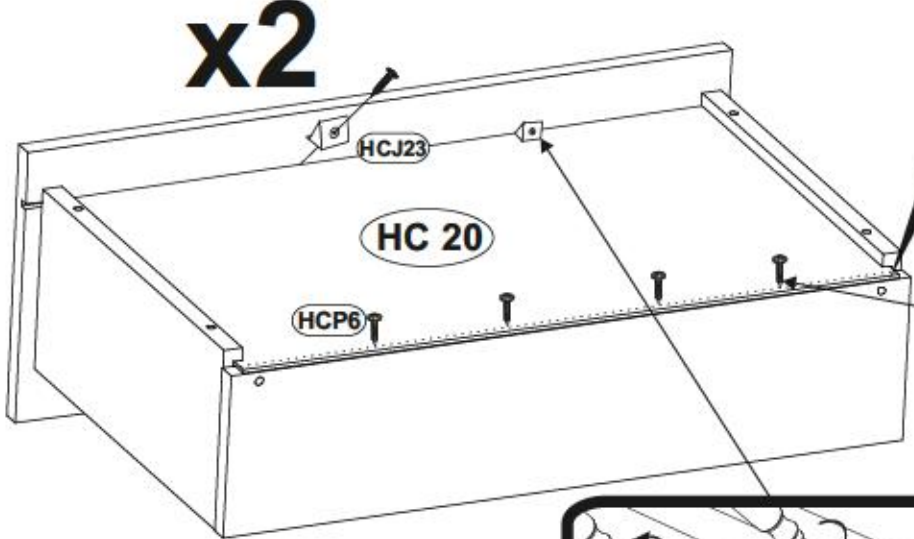

x2

x2



3

HCB1		10 18
	8x28	x8
HCM1		12 38 04
		x8
HCT1		118 09
		x4

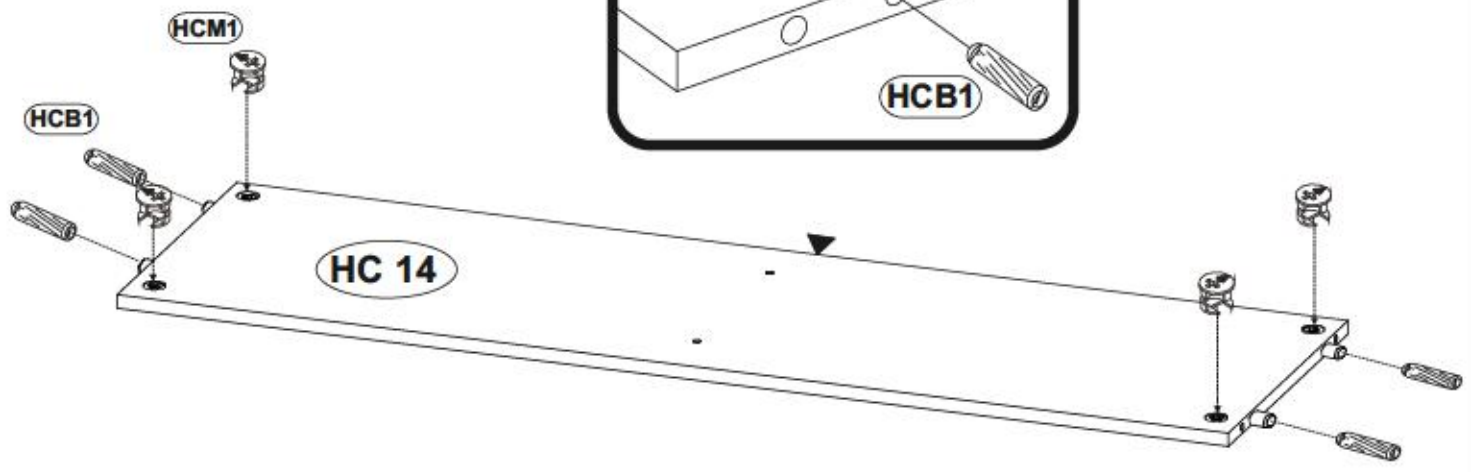
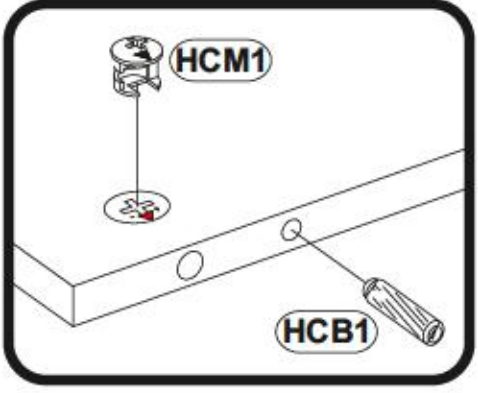
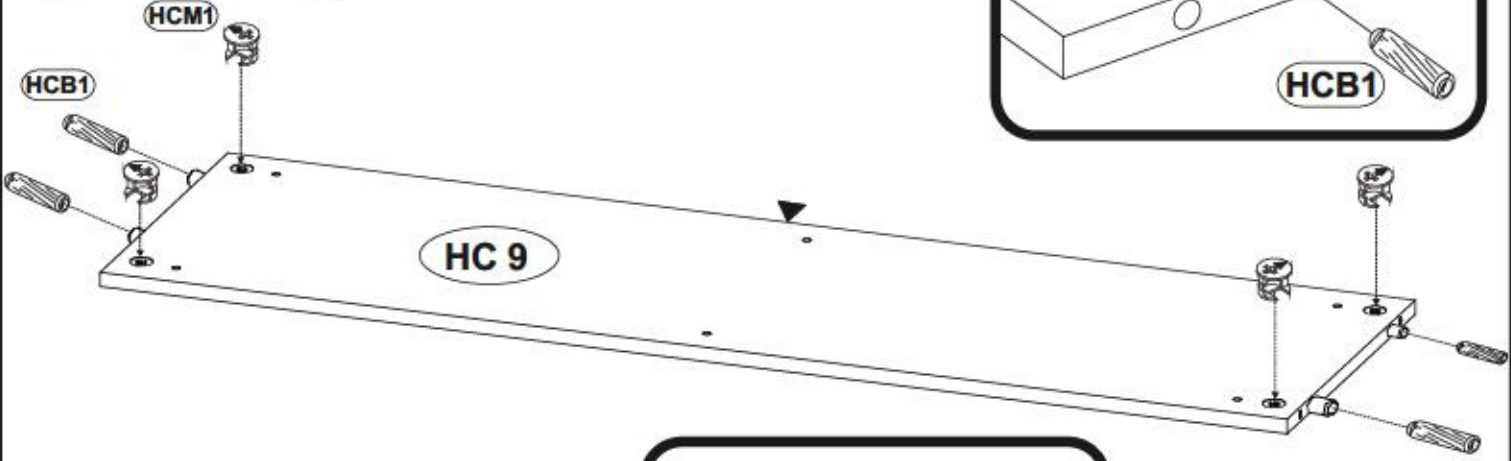
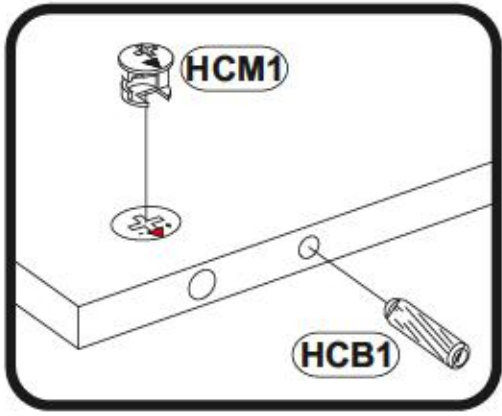
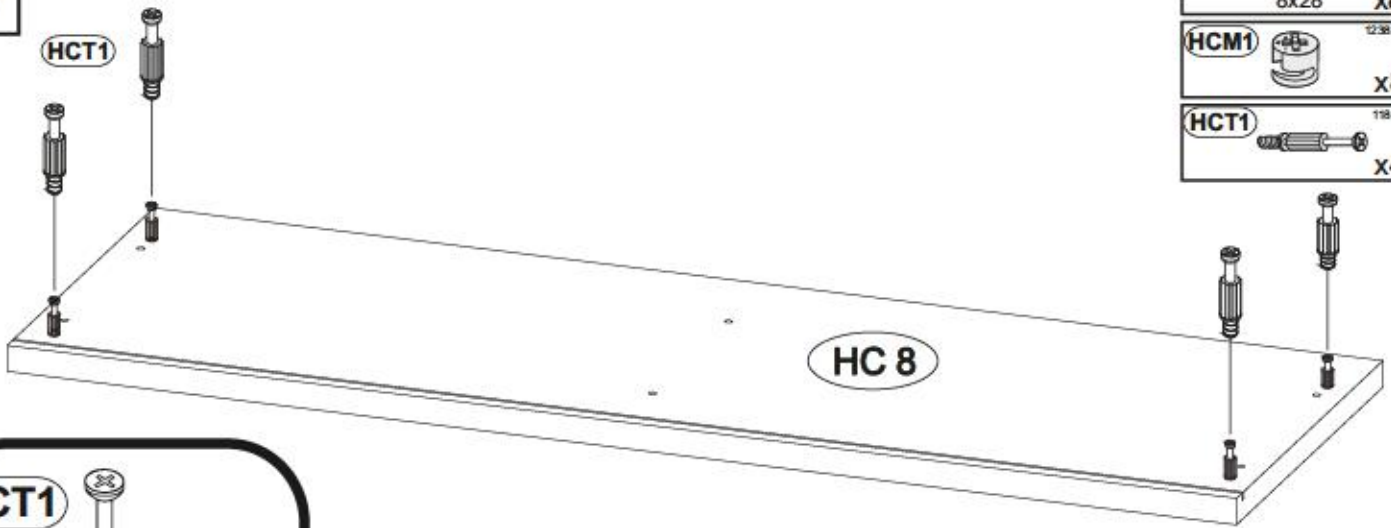

4

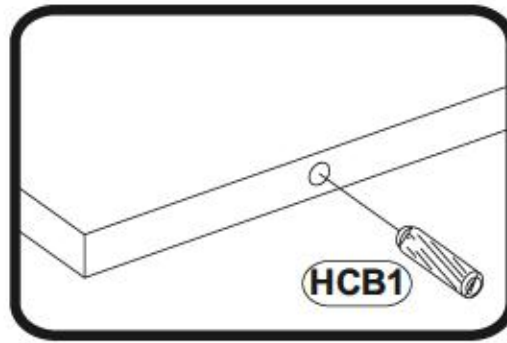
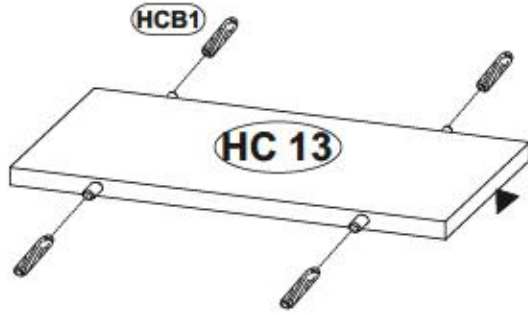

HCB1 1018
8x28 x10

HCR42 190 132
300 x2

HCE1 1008
ES 6,3x9,5 x8

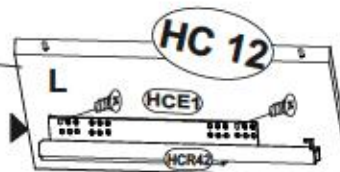
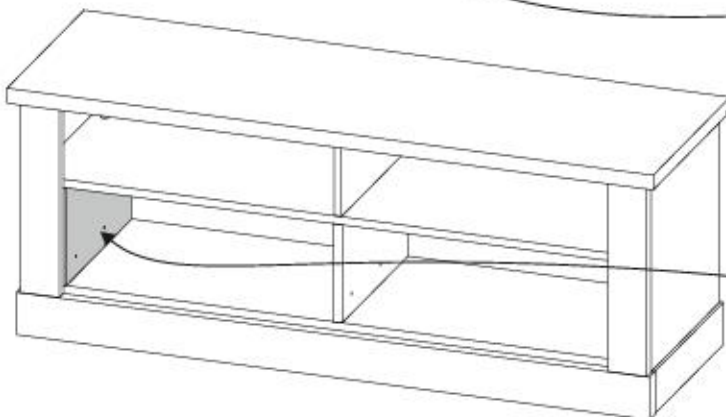
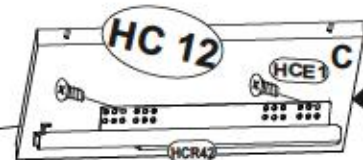
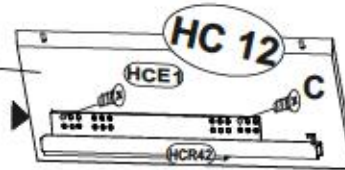
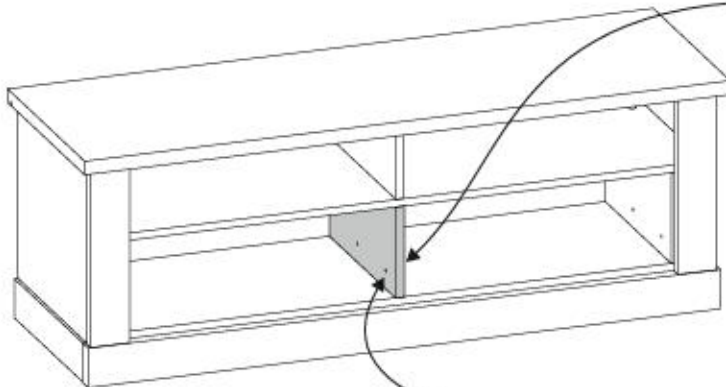
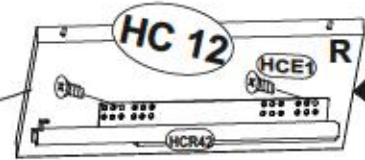
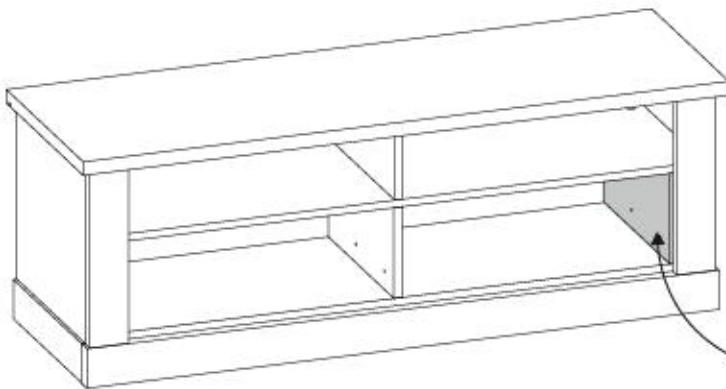
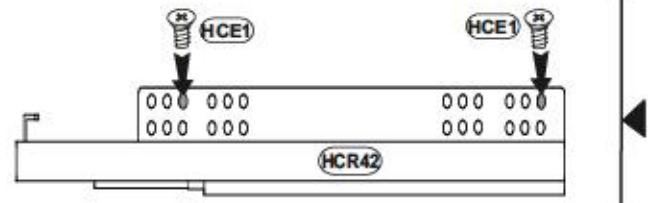
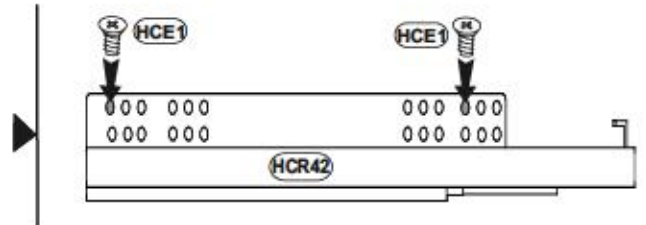
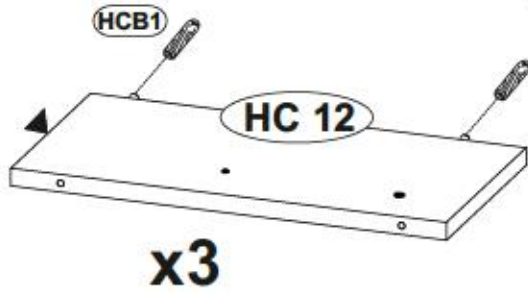

5

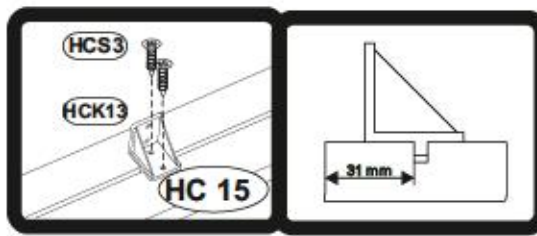

HCB1		10 18
	8x28	x4
HCM1		12 38 94
		x4
HCT1		118 03
		x8
HCK13		407 16
		x4
HCS3		10 11
	3,5x13	x8

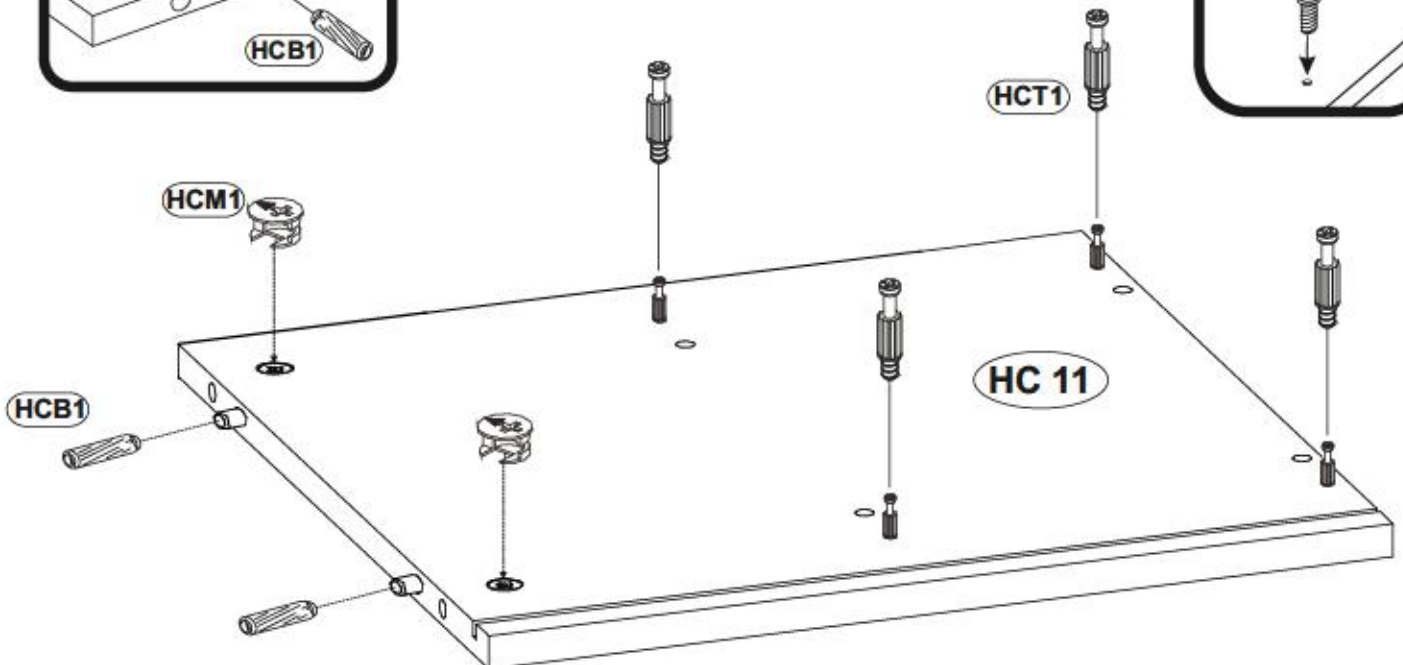
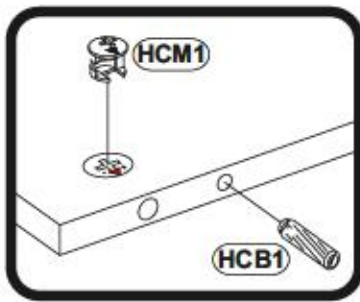
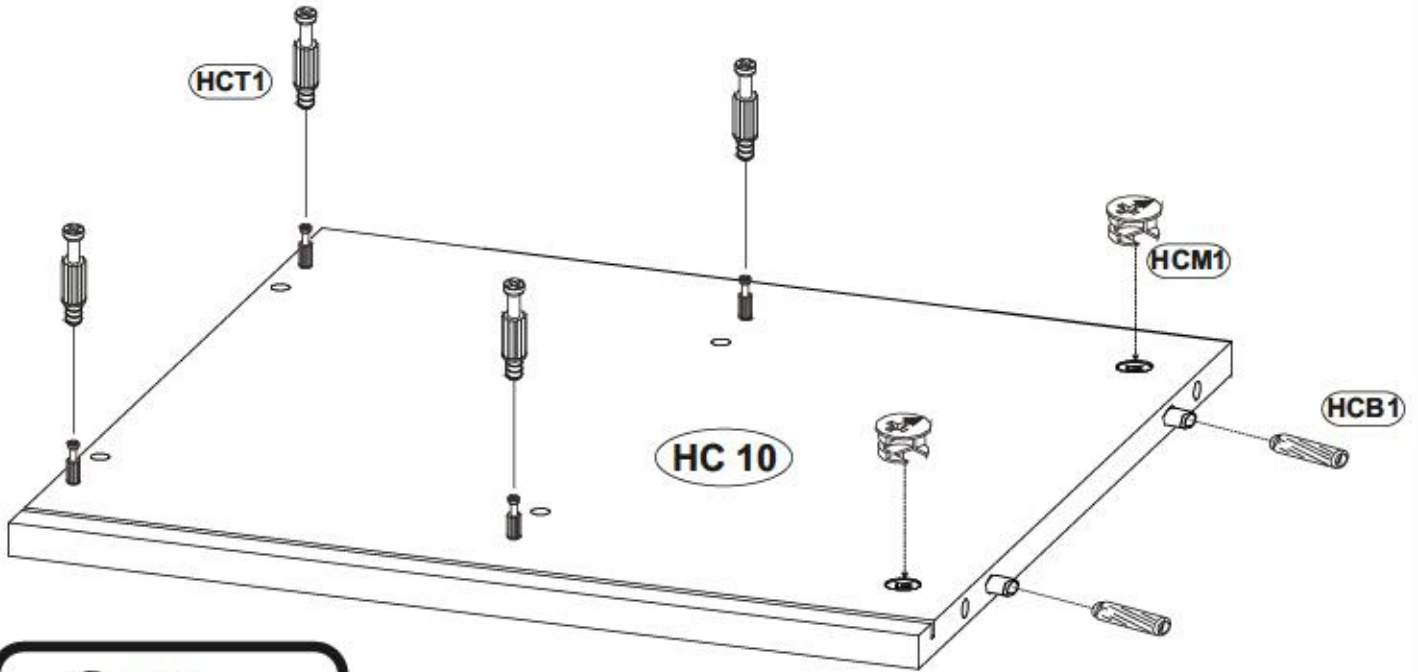
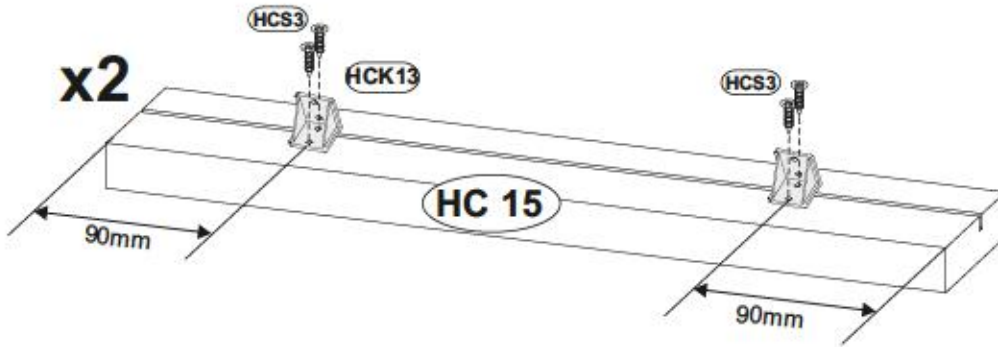

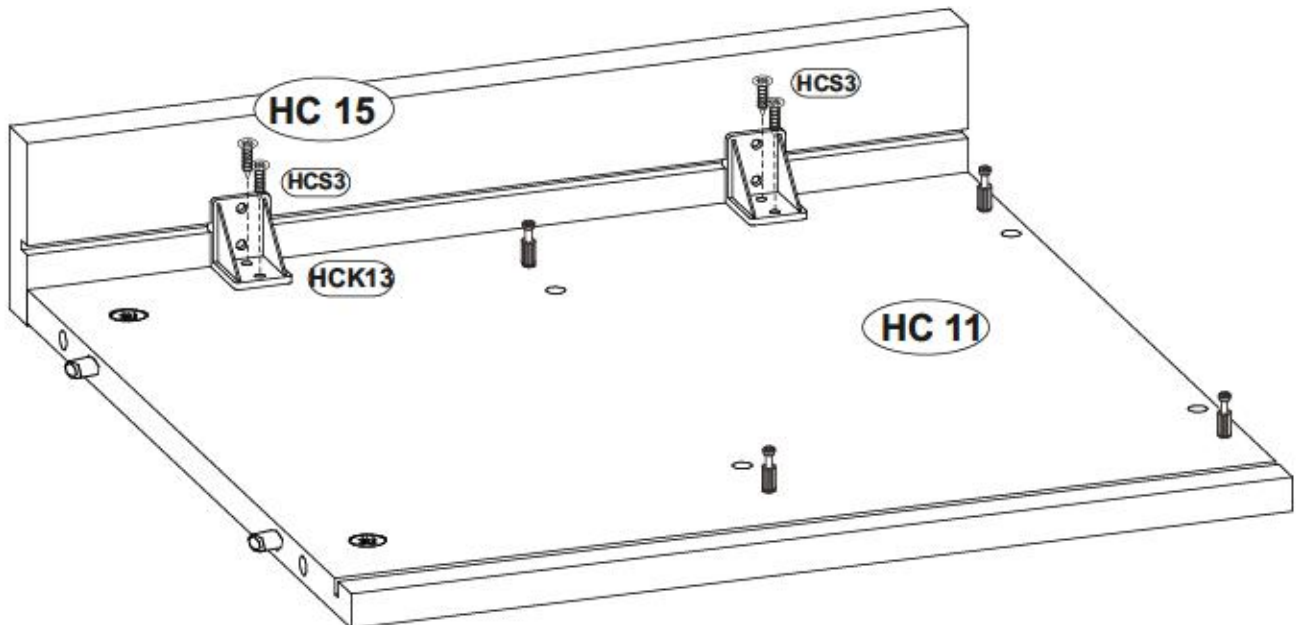
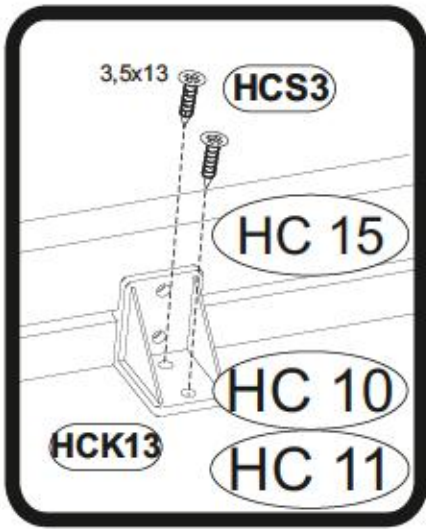
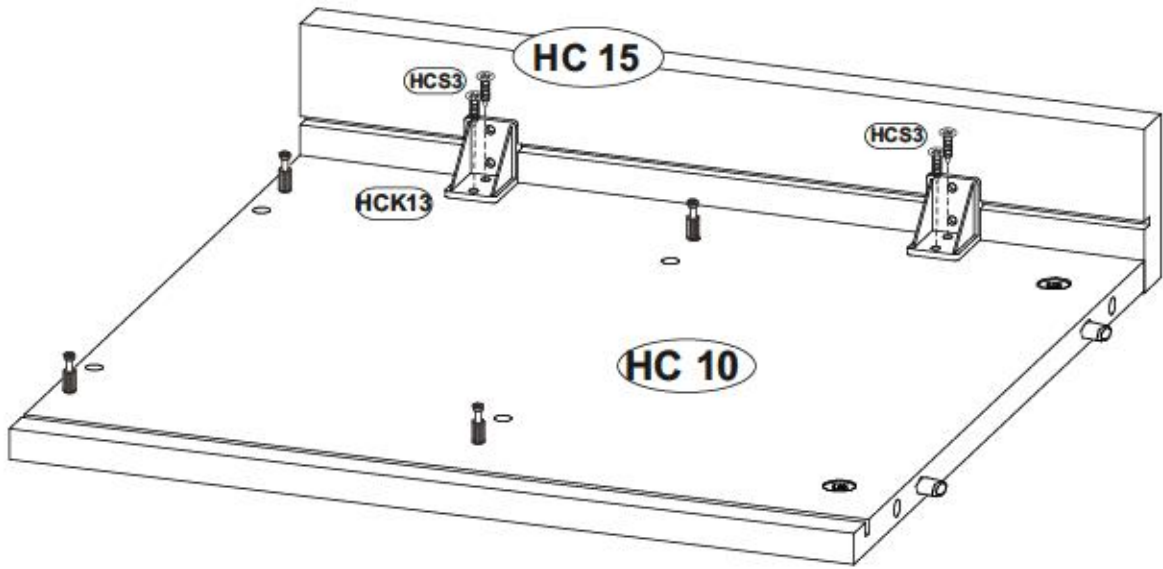

7

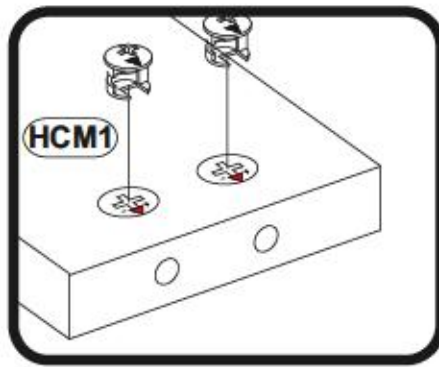

HCM1		123894	x8
HCT1		19809	x4
HCS3		1011	x4
HCK15		81556	x2
HCB1		1018	x4

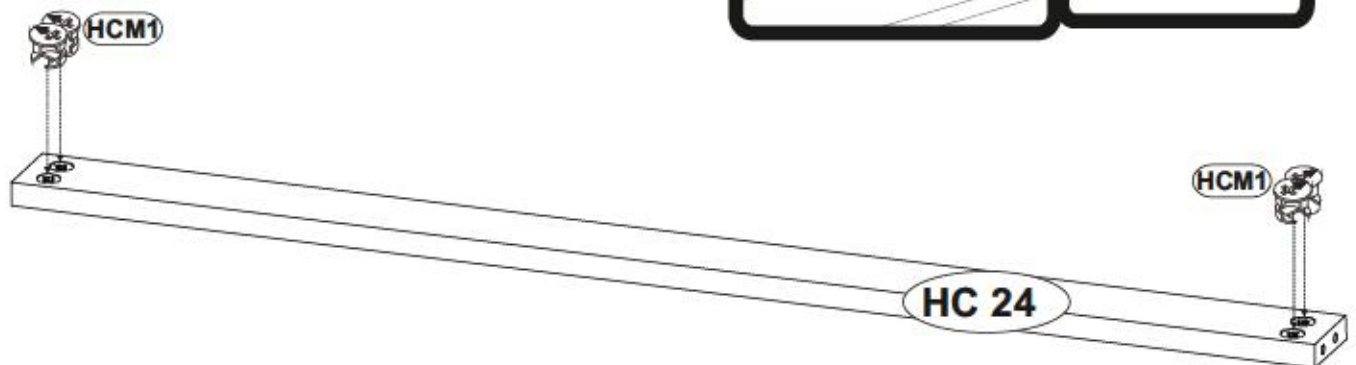
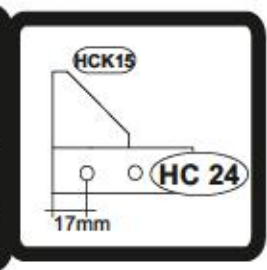
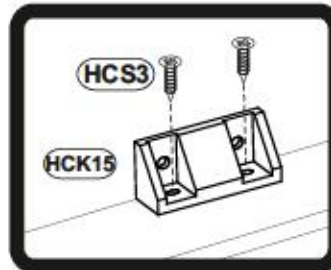
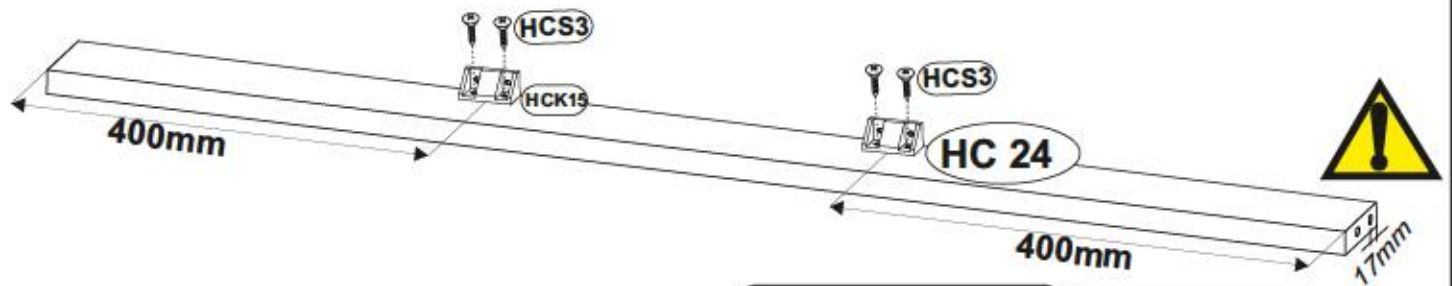
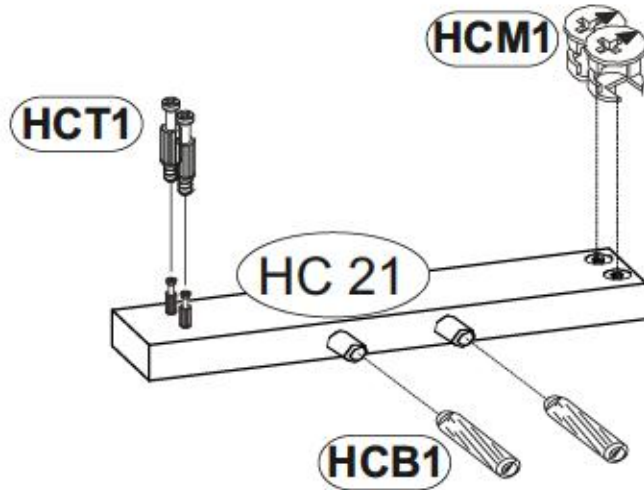
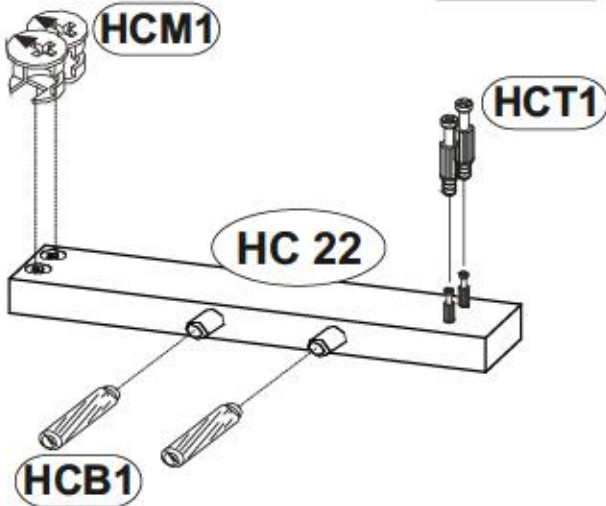

8

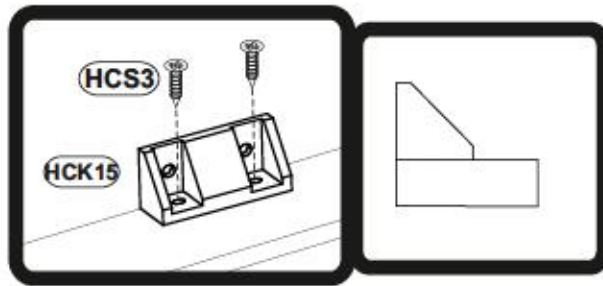

HCT1	11809		x4
HCS3	1011	3,5x13	x4
HCK15	81598		x2
HCF36	1305		x8

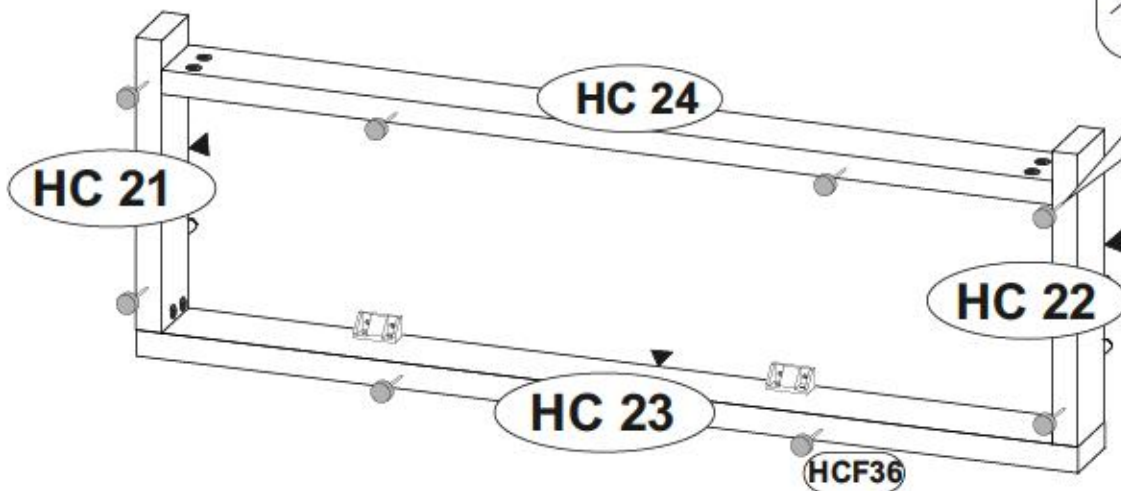
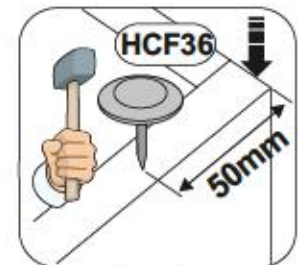
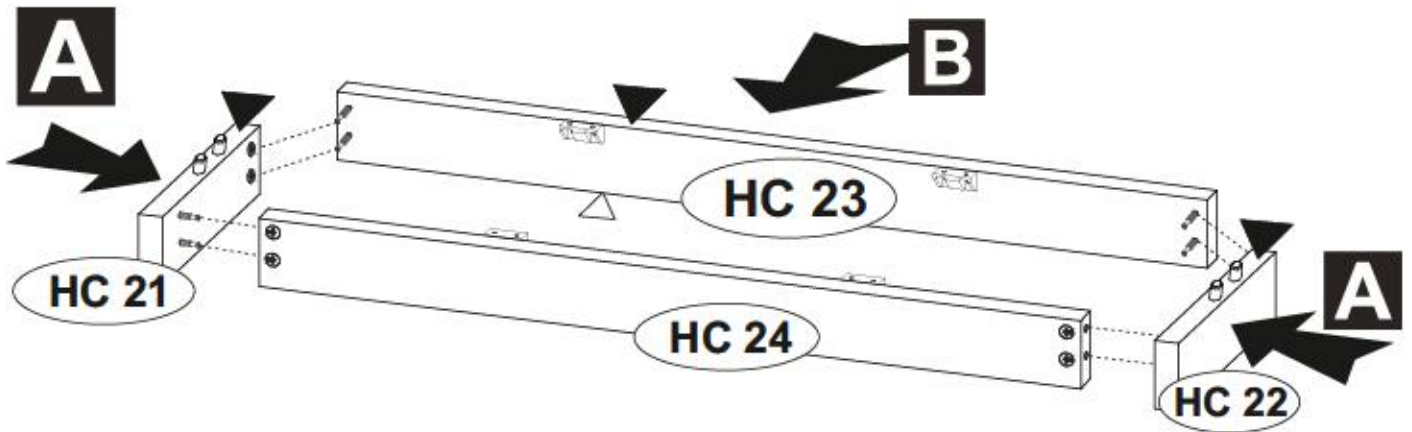
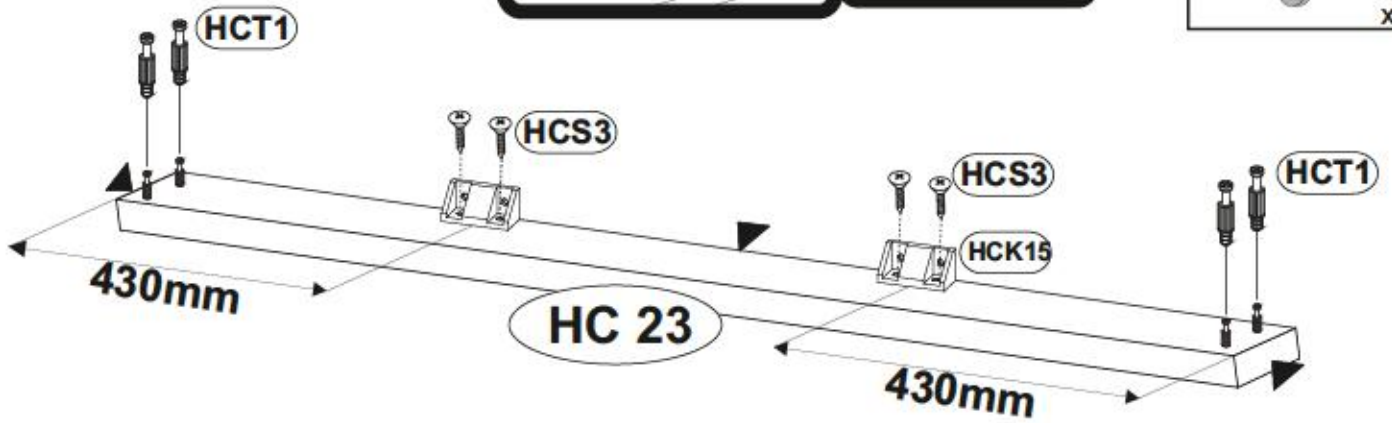

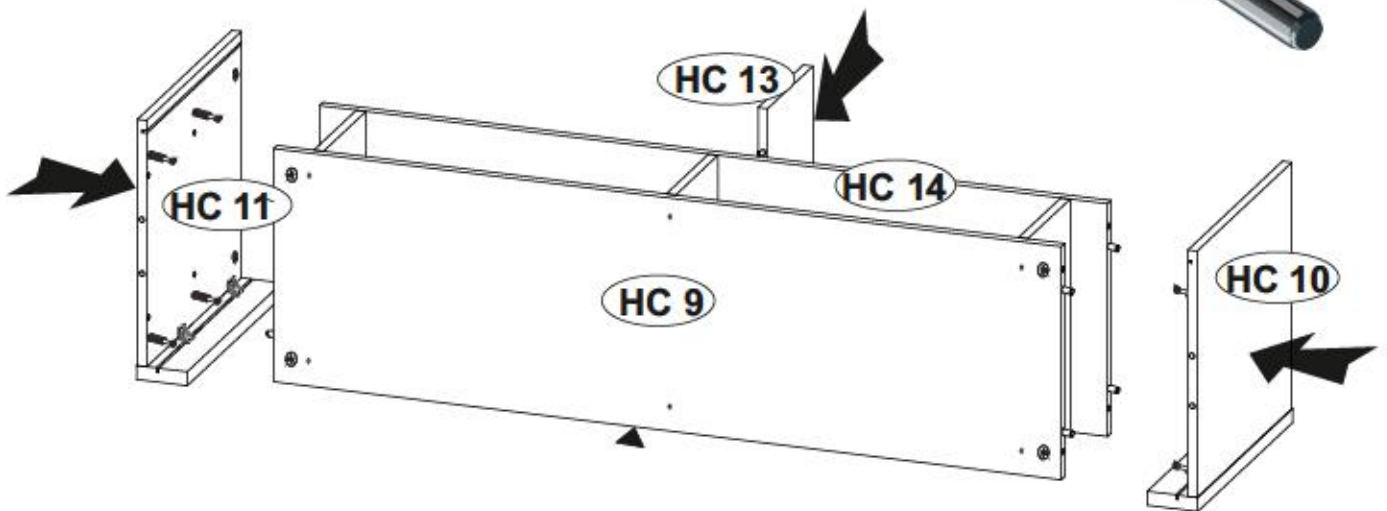
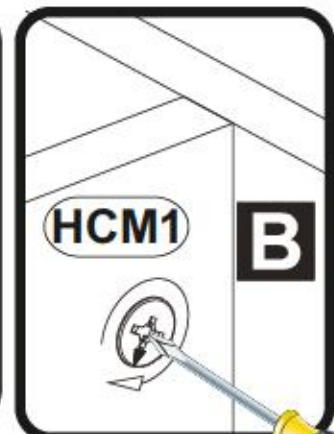
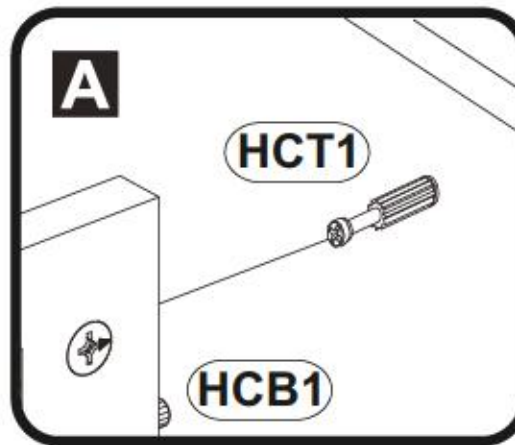
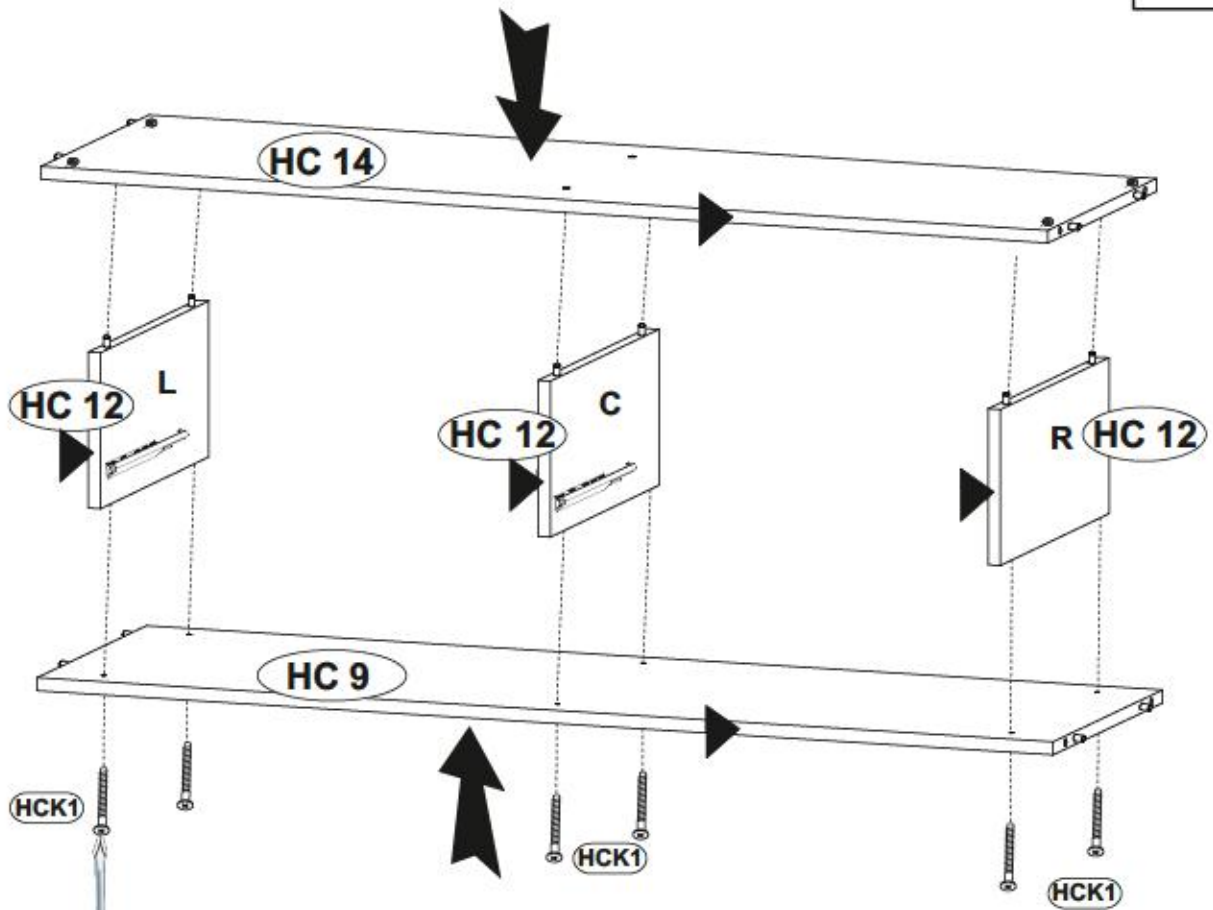

10

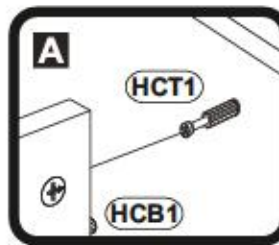
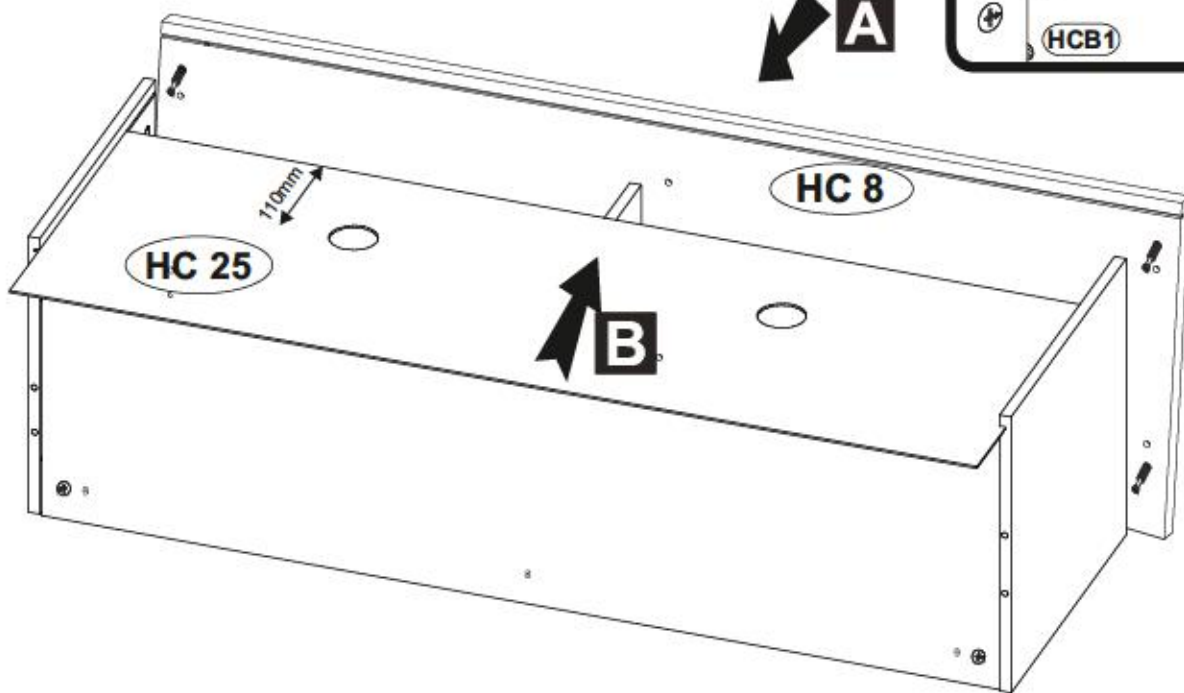

11

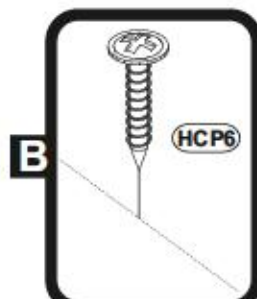
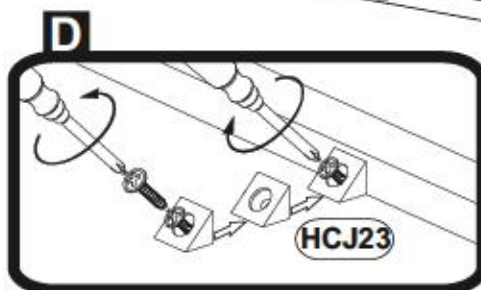
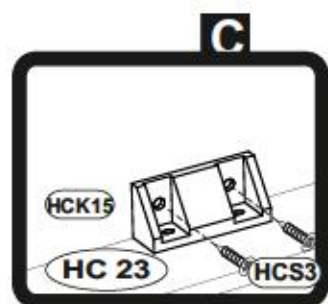
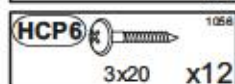
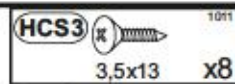
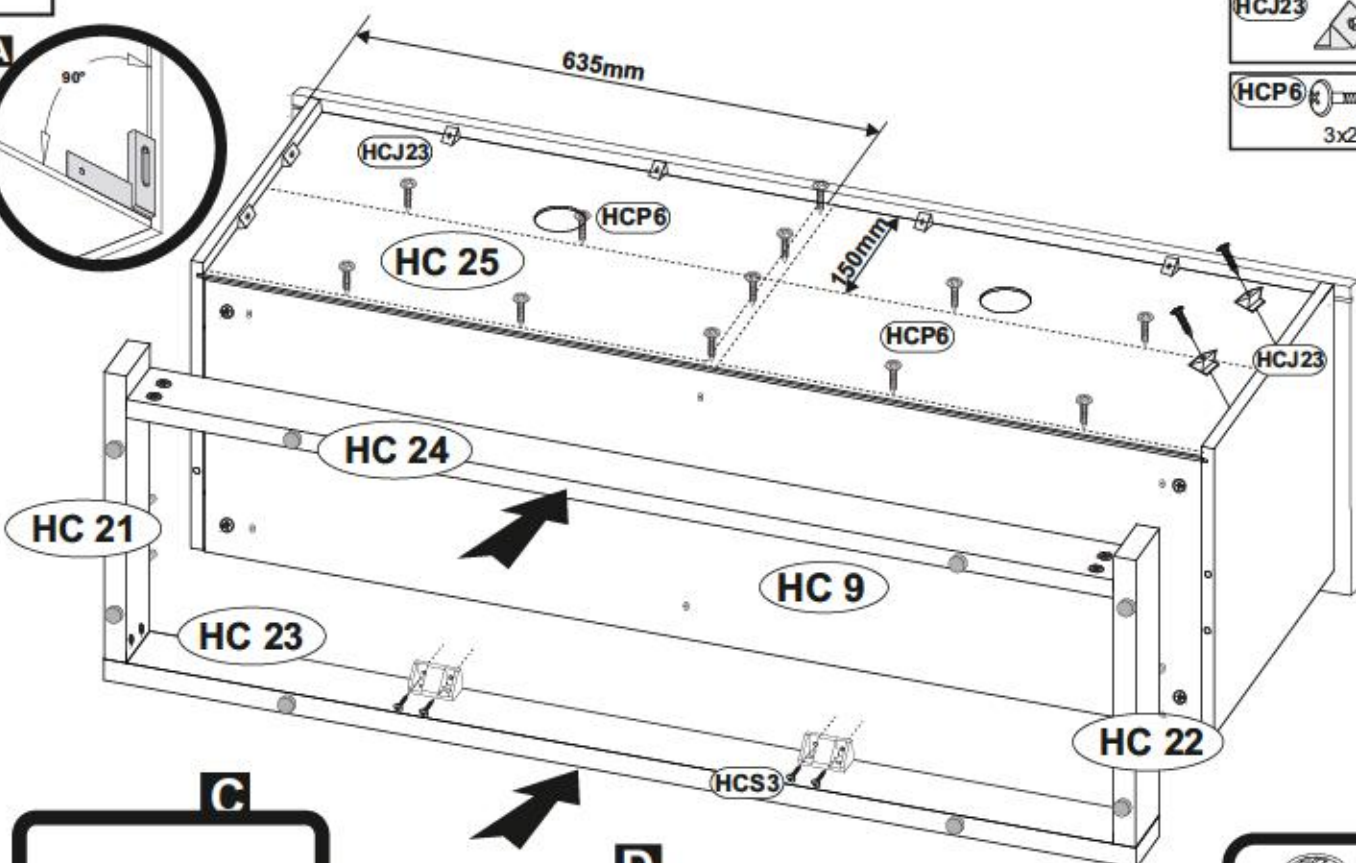
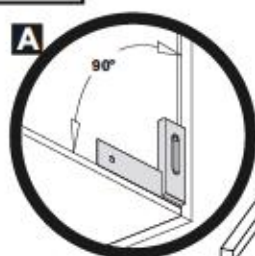

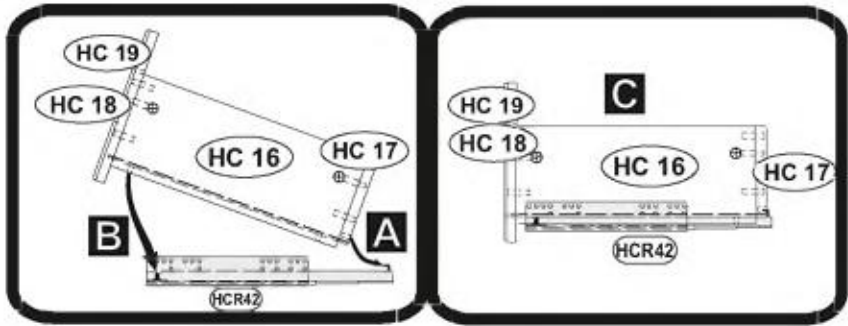

HCC6		140318
	φ20	x16
HCA4		144153
	WPM 4x18	x2
HCU4		954537
		x2
HCC13		138222
	φ 60	x2

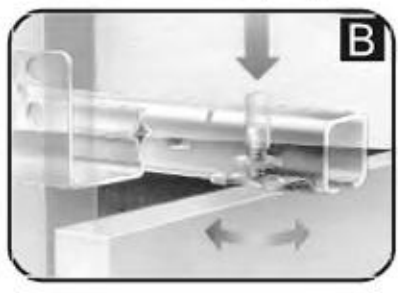
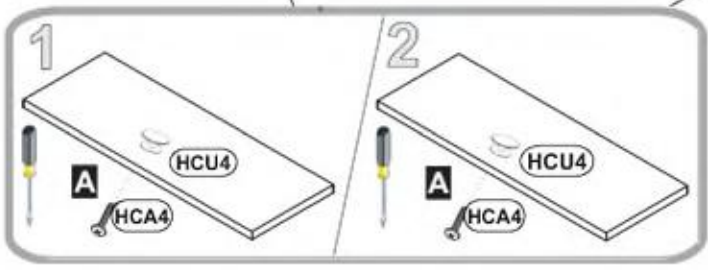
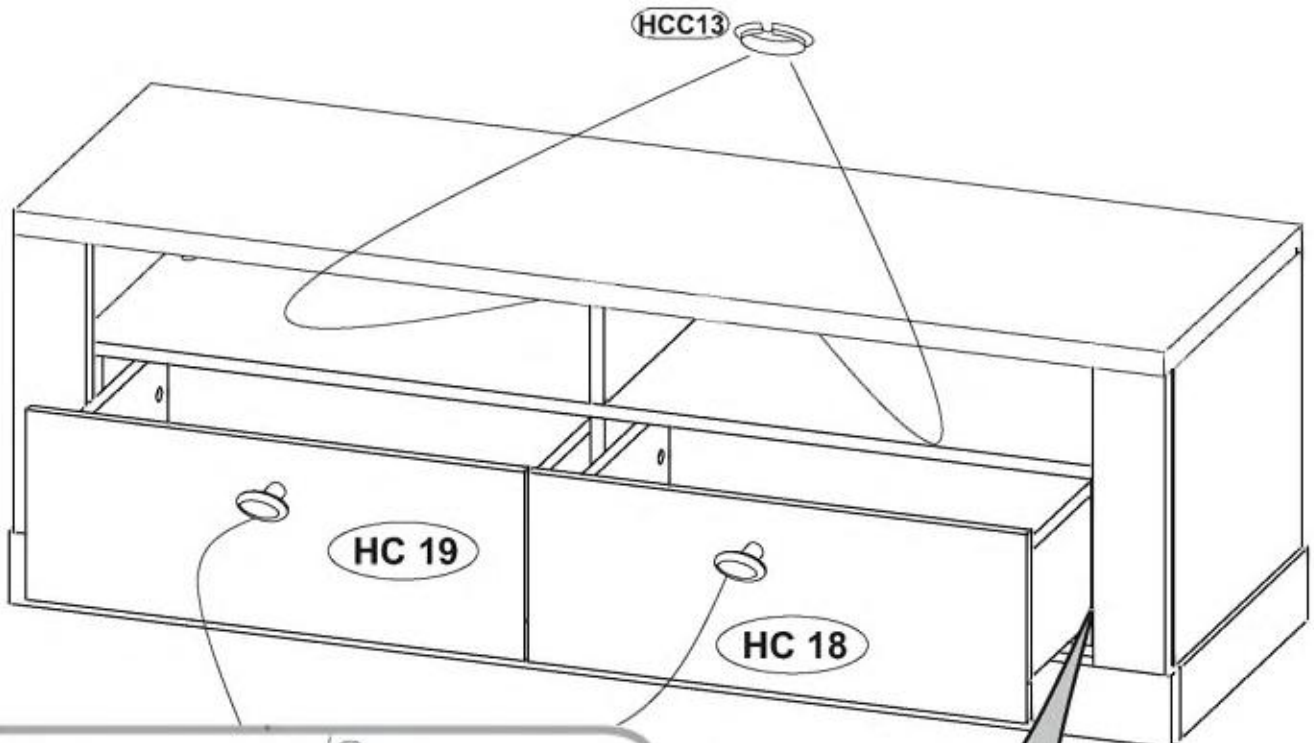

RAVENNA 31

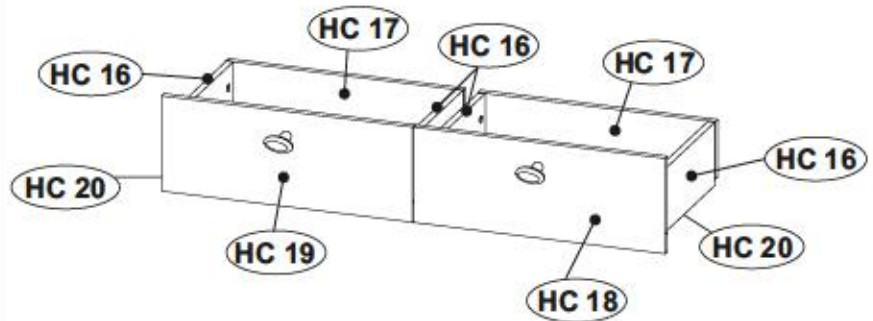
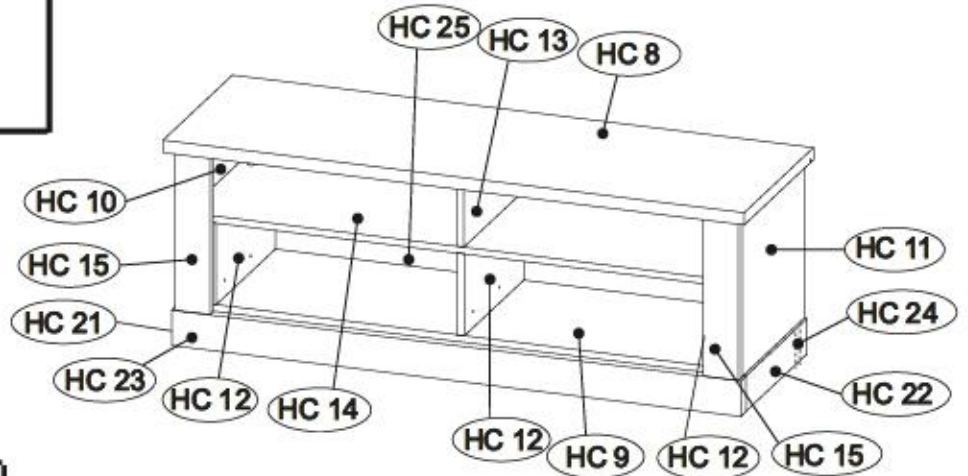

D Unser Direktversand für Beschädigte
 Soll Sie Ihren an Beschädigte fallen, können Sie diese Servicekarte direkt an die unterstehende Adresse mailen. Wir können allerdings nur Beschädigte auf diesem Wege verschicken. Sollten Sie eine andere Beanstandung an Ihrem Möbelstück haben, so wenden Sie sich bitte direkt an Ihre Möbel aus.

GB Our direct and service for fitting
 If a fitting part is missing, you can e-mail this service card directly to the address below. However, we can only send fitting parts in this way. If you have any other cause for complaint concerning your item of furniture, please contact your furniture store directly.

CZ Naše přímá služba pro kování
 Pokud Vám něco chybí či je poškozené, můžete tuto servisní kartu odeslat e-mailem přímo na níže uvedenou adresu. Toho ostatně však můžeme využít jen díky kování. Pokud byste reklamovali jiný díl nábytku, obrátte se přímo na svého prodejce nábytku.

F Bien utiliser la notice de montage
 Si il vous manque une ferrure, veuillez envoyer directement le présent carte service à l'adresse e-mail indiquée ci-dessous. Cependant, ceci ne peut permettre qu'uniquement d'envoyer des ferrures. Pour tout autre type de réclamation concernant votre meuble, veuillez contacter directement votre magasin d'ameublement.

I Il nostro servizio diretto per i danni della lavorazione
 Qualora Vi dovesse mancare un pezzo di fissaggio, allora Vi preghiamo di inviare questa carta di servizio immediatamente all'indirizzo sottostante. Possiamo inviare i pezzi di fissaggio solamente per mezzo di questo procedimento. Qualora doveste avere qualche altra reclamazione in merito al mobile, allora Vi preghiamo di rivolgervi direttamente al vostro Negozio di mobili.

BG Прямата услуга за обзавеждане
 Ако ви липсва част от мебелите, потържете настоящата сервисна карта и не я прагнете на е-мал адрес, защото по-рано. По този начин може да доставим само липсващи елементи от обзавеждането. Ако искате друга помощ по мебелите, се свържете директно с обзавеждащия магазин.

NL Onze directe hulp voor klemmen ontbreken
 Wanneer er een onderdeel ontbreekt, kunt u deze servicekaart direct aan ons adres en e-mailadres sturen. Wij kunnen langzame weg echter alleen beschadigingen verzenden. Mocht u een ander probleem aan uw meubel hebben, verzaken wij u contact op te nemen met uw meubeldealer.

PL Nasza bezpośrednia usługa dla uszkodzeń
 Jeżeli brakuje części konstrukcyjnych do montażu, prosimy o przesłanie nam niniejszej karty serwisowej na niżej podany adres e-mailowy. W ten sposób możemy przesyłać wyłącznie uszkodzone części. W przypadku innych reklamacji dotyczących mebli, prosimy zgłosić się do własnego sklepu meblowego, w którym został dokonany zakup.

HR Servisna usluga
 U slučaju oštećenja ili nedostajanja nekih od dijelova meblima vas de ne dođe u svetu nam mail adresu pošaljite ovaj servisni obrazac. Na ovaj način mogu se dostaviti samo oštećeni. U slučaju da imate dodatne prigovore vezane uz komad namještaja meblima vas de se obratiti izravno trgovcu namještaja gdje je isti kupljen.

HU Közvetlen szolgáltatás a károsodások esetén
 Ha hiányzik egy csavar, ez az igényt közvetlenül el kell érni az alábbi e-mail címen. Azonban csak a károsodott alkatrészek így küldhetők. Amennyiben másféle reklamációt állt lenn bátorodnánk a károsodás, forduljon közvetlenül a boltjához.

SK Naša priama služba pre škody kováčiek
 Ak by Vám chýbala niektorá časť kováčiek, môžete poslať túto servisnú kartu priamo na nižšie uvedenú adresu. Dôj kováčiek vieme poslať iba týmto spôsobom. Ak by ste mali inú reklamáciu ohľadom Vášho nábytku, obráťte sa priamo na Vášho predajcu nábytku.

SLO Naše direktna služba za obzaveževanje
 Če vam manjka kakšno okovje, lahko to serviso kartico pošljete po e-pošti direktno na spodnji naslov. Po besj pa lahko samo obzaveževanje s pomočjo te kartice. Če želite reklamirati kakšno drugo delovno površino, se obratite neposredno na vašo trgovino s pohištvi.

RO Serviciul nostru direct pentru daune
 În cazul în care vă lipsește o piesă de mobilier sau este deteriorată, puteți trimite direct această card de service prin e-mail la adresa de mai jos. Noi nu putem trimite decât piese de mobilier de către această adresă. Dacă aveți o altă reclamație referitoare la piesa de mobilier, atunci vă rugăm să vă adresați direct la magazinul dvs. de mobilier.

RUS Прямая услуга сервис для поврежденных фурнитур
 Если отсутствует, что Вам не хватает того или иного элемента фурнитуры, Вы можете отправить сервисную карту по адресу непосредственно на нижеприведенный адрес электронной почты. Однако, только поврежденные элементы фурнитуры можно доставить только по адресу. Если же у Вас имеются иные претензии по отношению к приобретенной мебели, пожалуйста, обращайтесь непосредственно к магазину, осуществляющему продажу.

S Vår direkte service för beskadigade
 Om du saknar en beskadigad del av möbelen eller om du har skadat en del av möbelen, kan du skicka denna servicekort direkt till e-postadressen som anges nedan. Men på ett delat sätt kan vi endast skicka skadade delar till dig. Om du vill reklamera din möbel av en annan anledning måste du kontakta ditt möbelutbudsköper.

ES Nuestro servicio directo para accesorios
 Si le falta algún accesorio, puede enviar esta tarjeta de servicio directamente a la siguiente dirección. No obstante, por este método solo podemos enviar accesorios. Si tiene alguna otra objeción sobre su mueble, consulte directamente con su mueblería.

TR Damızlar için doğrudan servis kartı
 Bir donanım elemanına veya servise kartına doğrudan başvurmanız doğrudan bir şekilde yapılabilir. Sadece bu şekilde donanım öğelerini doğrudan gönderebiliriz. Mebelenize başka bir şekilde zarar vermiş veya diğer donanım malzemelerini talep ederseniz, lütfen doğrudan mobilya satıcınıza başvur.

HC 8	x1	1316	431	28	1/1
HC 9	x1	1244	368	15	1/1
HC 10	x1	361	389	15	1/1
HC 11	x1	361	389	15	1/1
HC 12	x3	185	368	18	1/1
HC 13	x1	146	367	15	1/1
HC 14	x1	1244	368	15	1/1
HC 15	x2	361	80	22	1/1
HC 16	x4	313	140	15	1/1
HC 17	x2	534	126	15	1/1
HC 18	x1	553	210	15	1/1

HC 19	x1	553	210	15	1/1
HC 20	x2	515	334	2.5	1/1
HC 21	x1	386	80	28	1/1
HC 22	x1	386	80	28	1/1
HC 23	x1	1289	80	28	1/1
HC 24	x1	1231	80	28	1/1
HC 25	x1	1256	366	3	1/1

RAVENNA 31

HCB1  1018
8x28 X...

HCM1  123894
X...

HCT1  11809
X...

HCH23  1302
X...

HCK1  1354
7x50 X...

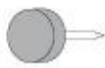
HCF36  1305
X...

HCC6  140318
φ20 X...

HCK13  49716
X...

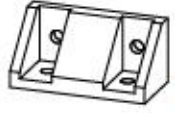
HCK15  81556
X...

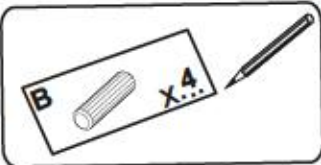

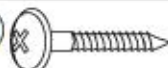
HCP6  1056
3x20 X...

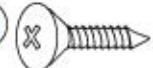
HCS3  1011
3,5x13 X...

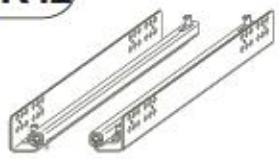
HCR42  14594
300 X...

HCU4  154537
X...

HCA4  14419
WPM 4x18 X...

HCC13  13822
φ 60 X...

HCE1  1008
ES 6,3x9,5 X...

D Unser Dienstservice für Beschädigte
Solange Ihnen ein Beschädigtes fehlen, können Sie diese Servicekarte direkt an die untenstehende Adresse mailen. Wir können eine Bestellung nur Beschädigte auf diesem Wege verschicken. Sollten Sie eine andere Beschreibung an Ihnen Mithelstock haben, so wenden sie sich bitte direkt an Ihr Möbelhaus.

GB Our direct order service for fitting
If a fitting part is missing, you can e-mail this service card directly to the address below. However, we can only send fitting parts in this way. If you have any other cause for complaint concerning your item of furniture, please contact your furniture store directly.

CZ Někdy přijmí akvizice pro kování
Chybí-li vám nějaký díl z kování, můžete tuto službu i bez účtu objednat e-mailem přímo na náš ústřední adresou. Pokud chcete však mít přesnější informace, je třeba kontaktovat přímo náš obchodní stánek, abyste se přímo na vlastní předání nábytku.

F Bien arrivé en la notice de montage
Si vous remarque une erreur, veuillez en aviser directement le présent carte sans ce l'adresse e-mail indiquée ci-dessous. Cependant, ceci nous permet uniquement d'envoyer par ce moyen. Pour tout autre type de réclamation concernant votre meuble, veuillez contacter directement votre magasin d'ameublement.

I Il nostro servizio diretto per il cambio delle fermature
Quando Vi dovesse mancare un pezzo di fissaggio, allora Vi preghiamo di inviare questa carta di servizio immediatamente all'indirizzo sotto indicato. Possiamo inviare i pezzi di fissaggio solamente per mezzo di questo procedimento. Qualora dovete avere qualche altra richiesta o se in merito al mobile, allora Vi preghiamo di rivolgerVi direttamente al Vostro Negozio di mobili.

BG Намамата директно износване на обнова
Ако ви липне част от мебелите, потърсете некое от нашите директни адреси и ни е препоръчително да ви пишем директно по-долу. По този начин можем да доставим само запорни елементи от обнова. Ако искате да получите повече информация, моля, свържете се с обновения магазин, в който сте закупили мебелите.

NL Onze directservice voor lozen of anderszins
Wanneer we een onderdeel ontbrekt, kunt u deze servicekaart direct aan ons toezenden die-vestiging adrese. Wij kunnen lange deze weg echter alleen beschadigden verzenden. Mocht u een ander probleem aan uw meubel hebben, verzaken wij u contact op te nemen met uw meubelwinkel.

PL Nasz bezpośredni serwis części montażowych
Jeżeli brakuje części koniecznych do montażu, prosimy o przesłanie nam niniejszej karty bezpośrednio na nasz podany adres e-mailowy. W ten sposób możemy przesyłać. Ponadto tylko brakuje części. W przypadku innych reklamacji dotyczących mebla, prosimy zgłaszać się do naszego meblowego, w którym zostało dokonany zakup.

HR Servis zaokona
U slučaju da nedostaje neki od dijelova meblu vas da ne dalje nevedeno mail adresu pošaljete ovaj servisni obrazac. Na ovaj način mogu se dostaviti samo okona. U slučaju da imate dodatne prigovore vezane uz komad namještaja molimo vas da obratite izravno trgovini na mjestu gdje je isti kupljen.

HU Direktrendelésért a kivétel nélkül
Ha hiányzik egy részlet, azt a kérést közvetlenül a közölt címre az alább látható címre. Azonban csak a kivétel nélkül a fenti tárgyú kérések. Amennyiben más kérdés merül fel a fenti tárgyú kérésekkel kapcsolatban, forduljon közvetlenül a bolti részleghez.

SK Někdy přijmí akvizice pro kování
Ak by Vám chýbala niekajá časť kovania, môžete požadovať kúpu služby i bez účtu priamo na náš ústredný adresou. Chyby kovania viete požadovať iba týmto spôsobom. Ak by ste mali inú reklamáciu ohľadom Vašho nábytku, obráťte sa priamo na Vašu predajňu nábytku.

SLO Někdy přijmí akvizice pro kování
Či vám chýbajú niektoré dielky, môžete túto službu i bez účtu objednať e-mailom priamo na náš ústredný adresou. Ak chcete však mať presnejšie informácie, je potrebné kontaktovať priamo náš obchodný stánek, abyste sa mohli priamo na vlastnú predajňu nábytku.

RO Serviciu de montaj direct pentru fierare
In cazul in care va lipseste o piesa de fierare, puteti sa trimbate direct acest card de serviciu prin e-mail la adresa de mai jos. Noi nu putem expedia piesa de fierare direct pe aceasta cale. Dacă aveți o altă reclamație referitoare la piesa de mobilier, atunci vă rugăm să vă adresați direct la magazinul dvs. de mobilier.

RUS Наш прямой сервис для поставок фурнитуры
Если отсутствует, что Вам не хватает того или иного элемента из фурнитуры, Вы можете отправить сервисную карту по адресу непосредственно на наш главный адрес электронной почты. Однако, только в этом случае мы сможем доставить только фурнитуру. Если же у Вас имеются другие претензии относительно приобретенной мебели, пожалуйста, обращайтесь непосредственно в магазин, в котором была куплена мебель.

S Vår direkte service for beskadigede
Om du sakner en beskadiget led i et skadet eller servicekort direkte til e-postadressen som angives nedenfor. Tilkøb af led eller andre møbeldelen kan kun bestilles direkte til os. Hvis du har andre klager om møbel, bedes du kontakte den butik, hvor møbelen blev købt.

ES Nuestro servicio directo para accesorios
Si le falta algún accesorio, puede enviarnos este tarjeta de servicio de reclamos a la siguiente dirección. No obstante, por solo modo de solo podemos enviar accesorios. Si tiene alguna otra objeción sobre su mueble, consulte directamente con su mueblería.

TR Doğrudan siparişleriniz için
Bir ürününüz eksikse bu servise kartini dogrudan ilgili butun adresne dogrudan mail ile iletiniz. Sadece bu yolla direkt siparisleriniz. Mobilyanızla ilgili diğer sorularinizi de bu adresle dogrudan mobilya satilicinizla yapiniz.

RAVENNA 71

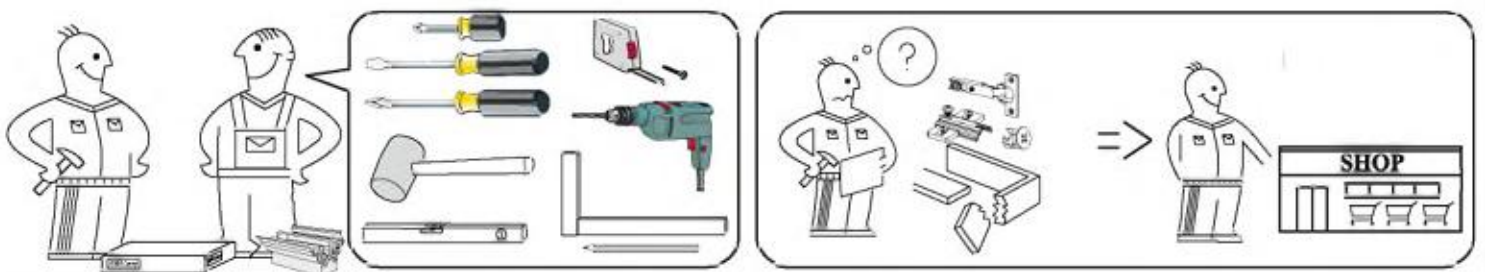
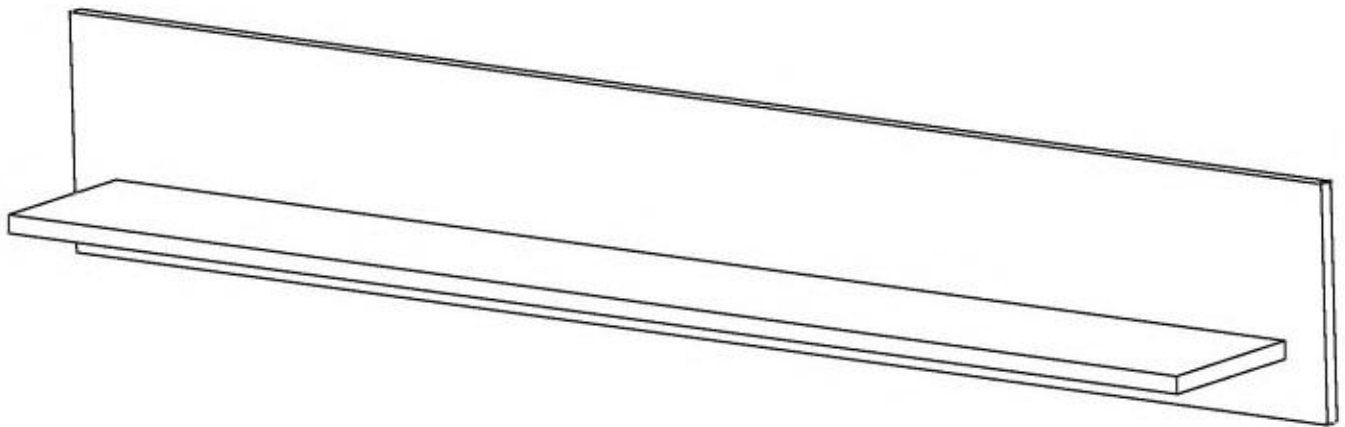

RAVENNA 71

max.



HC 56

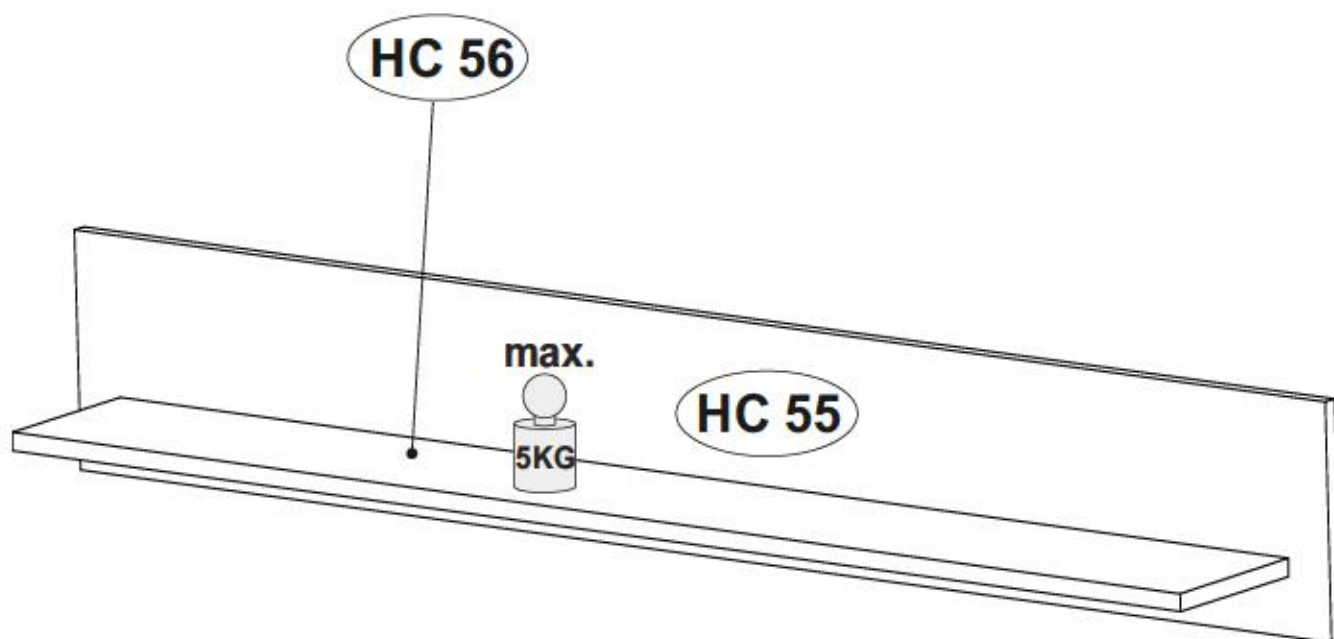

HC 55	x1	1500	200	15	1/1
HC 56	x1	1400	169	28	1/1

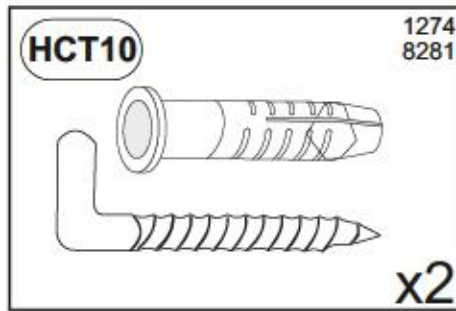
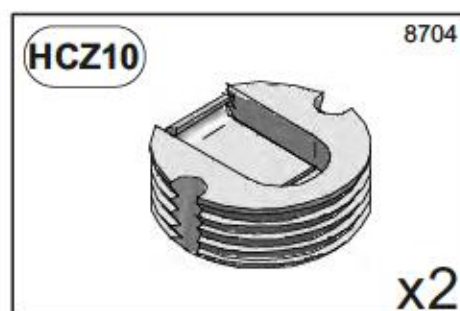
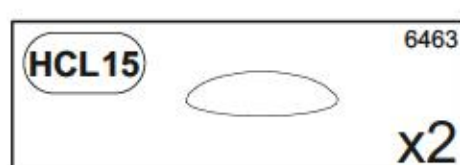
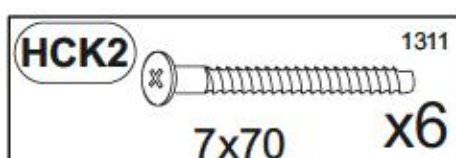
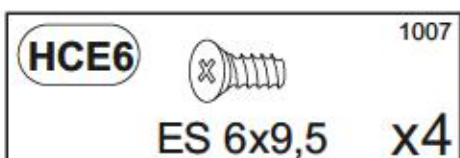

1

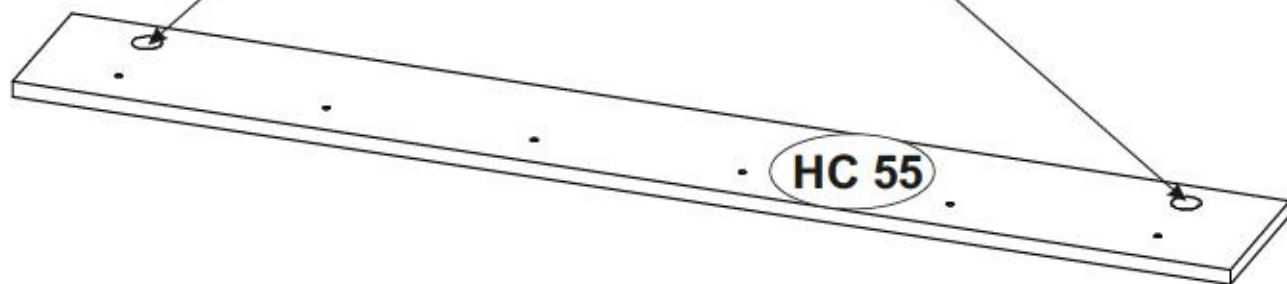
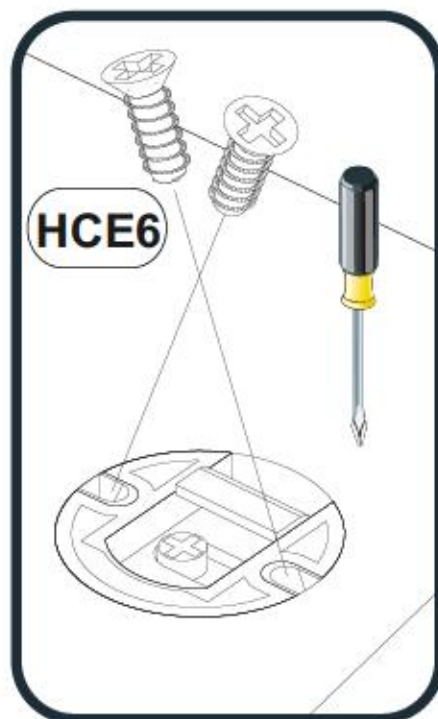
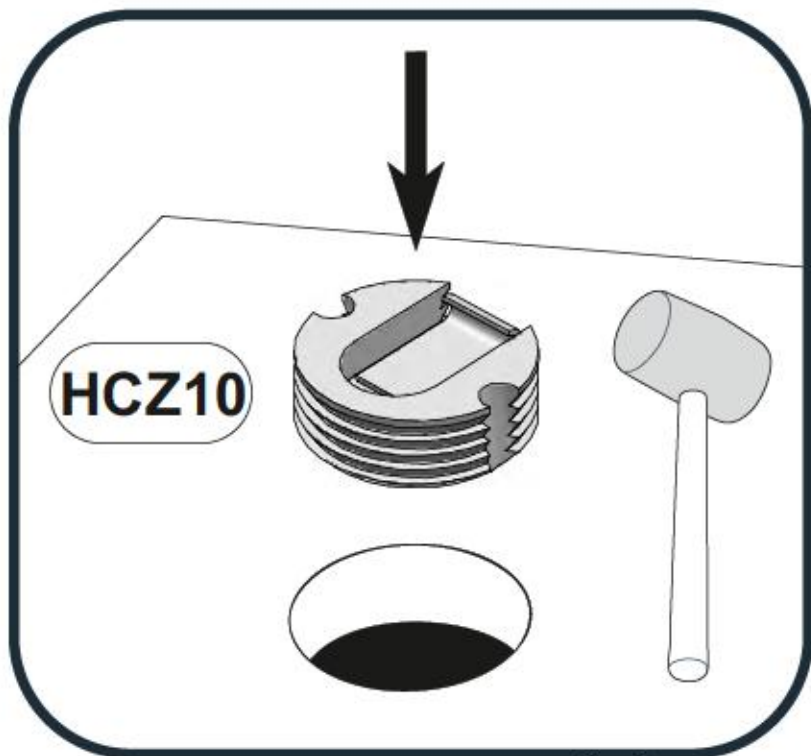
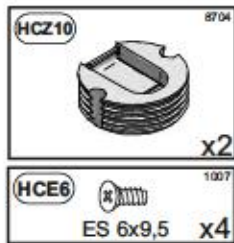

2

HCK2
7x70 x6

HCL15
9483
x2

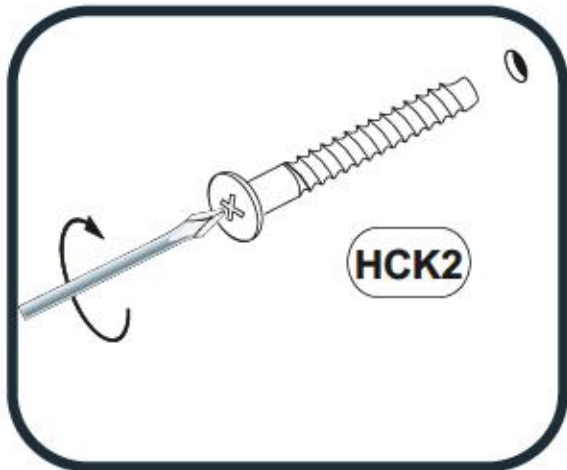
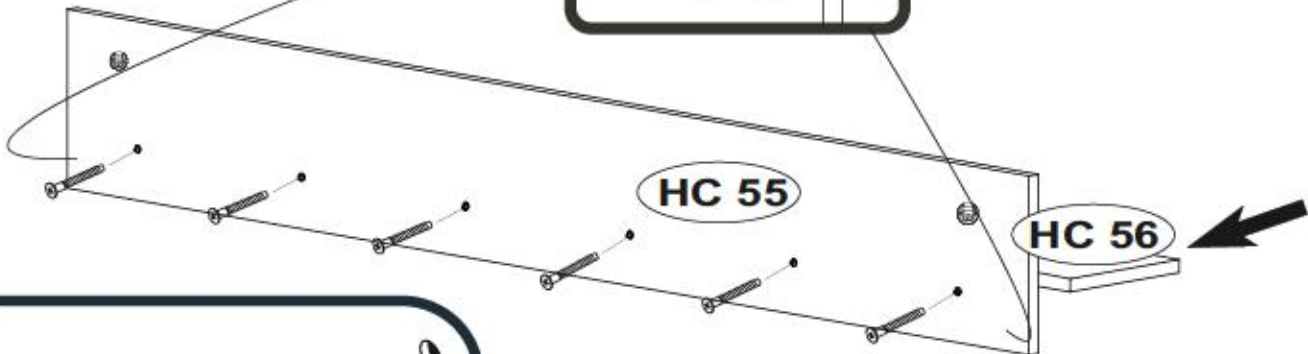
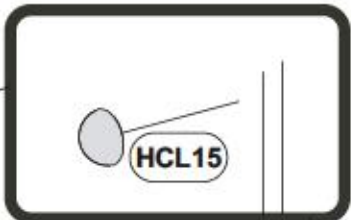

3

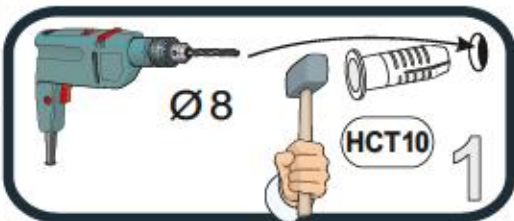

HCT10
1274
8281
x2

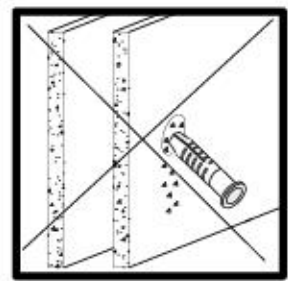
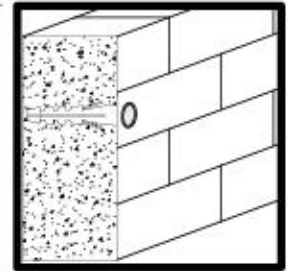
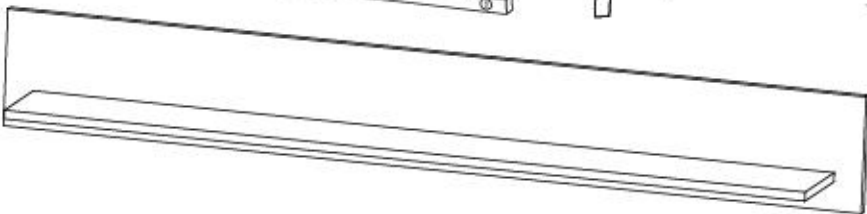
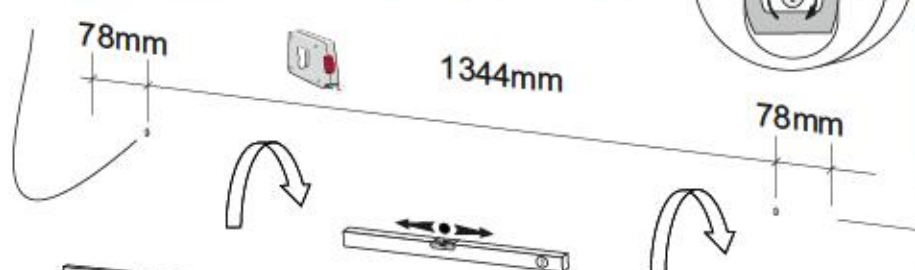

RAVENNA 71

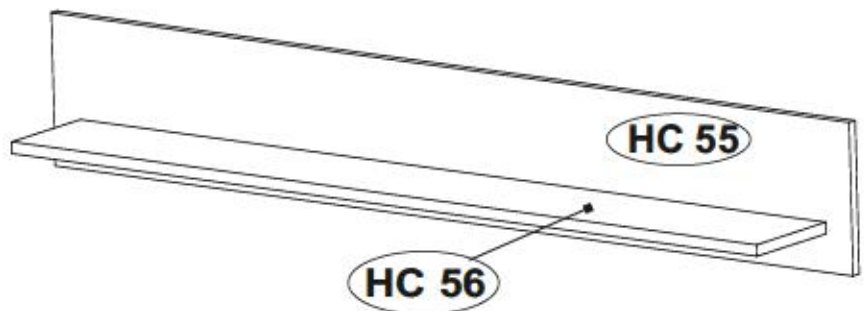

D Utwór: Drukownice i.r. Besch: Legale
Sollte Ihnen ein Beschädigtes Teil, können Sie diese Servicekarte direkt an die untenstehende Adresse mailen. Wir können allerdings nur Beschädigte auf diesem Wege verschicken. Sollten Sie eine andere Beanstandung an Ihrem Möbelstück haben, so wenden sie sich bitte direkt an Ihre Möbelhaus.

GB Our direct and service for fitting
If a fitting part is missing, you can e-mail this service card directly to the address below. However, we can only send fitting parts in this way. If you have any other cause for complaint concerning your item of furniture, please contact your furniture store directly.

CZ Naše přímá služba pro kování
Chybí-li vám nějaký díl z kování, můžete tuto servisní kartu odeslat e-mailem přímo na níže uvedenou adresu. To ale odeslat však můžeme pouze tehdy, pokud jde o reklamaci dílu. Pokud byste reklamovali jiný díl nábytku, obrátte se přímo na svého prodejce nábytku.

F Bien utiliser la notice de montage
Si il vous manque une ferrure, veuillez envoyer directement la présente carte service à l'adresse e-mail indiquée ci-dessous. Cependant, ceci nous permet uniquement d'envoyer des ferrures. Pour tout autre type de réclamation concernant votre meuble, veuillez contacter directement votre magasin d'ameublement.

I Il nostro servizio diretto per l'ordine della ferramenta
Qualora Vi dovesse mancare un pezzo di fissaggio, allora Vi preghiamo di inviare questa carta di servizio immediatamente all'indirizzo sottostante. Possiamo inviare in pezzi di fissaggio solamente per mezzo di questo procedimento. Qualora doveste avere qualche altra reclamazione in merito al mobile, allora Vi preghiamo di rivolgervi direttamente al vostro Negozio di mobili.

BG Прямата услуга за монтаж на обзавеждане
Ако ви липне част от обзавеждането, поточноме доставката на частите на мебелите, можете да ни изпратите на е-мал адреса, посочен по-долу. По този начин можем да доставим само липсващи частини от обзавеждането. Ако искате да ни направите друга жалба по отношение на мебелите, ще сме ви благодарни да се обърнете към местната продажбена точка, от която сте закупили мебелите.

NL Onze directe service voor het bestellen van de hardware
Wanneer er een onderdeel ontbreekt, kunt u deze servicekaart direct aan ons sturen en e-mailen naar sturen. Wij kunnen langedurend wijzigen alleen beschadigde onderdelen. Mocht u een ander probleem aan uw meubel hebben, verzaken wij u contact op te nemen met uw meubeldealer.

PL Nasza bezpośrednia usługa montażowa
Jeżeli brakuje części konstrukcyjnej do montażu, prosimy o przesłanie nam niniejszej karty serwisowej na niżej podany adres e-mailowy. W ten sposób możemy przesłać wyłącznie uszkodzone części. W przypadku innych reklamacji dotyczących mebli, prosimy zgłosić się do sklepu meblowego, w którym został dokonany zakup.

HR Servisna usluga
U slučaju da nedostaje neki od dijelova meblima vas de ne dolo navedenu mail adresu pošaljite ovaj servisni obrazac. Na ovaj način mogu se dostaviti samo oštećeni. U slučaju da imate dodatne prigovore vezane uz komad namještaja meblima vas de se obratiti izvorno trgovini namještaja gdje je isti kupljen.

HU Közvetlen szolgáltatás a csavarok, szeletek esetében
Ha hiányzik egy szelet, ez az helyét kiegészítőit elköltés az alábbi e-mail címre. Azonban csak a csavarokhoz lehet küldeni így. Minden egyéb meblel kapcsolatos reklamációt állt kell fordulni a helyi bolti eladóhoz.

SK Naša priama služba pre špeciálne kovania
Ak by Vám chýbala niekajka časť kovania, môžete poslať túto servisnú kartu priamo e-mailom na nižšie uvedenú adresu. Dôly kovania vieme poslať iba týmto spôsobom. Ak by ste mali inú reklamáciu ohľadom Vášho nábytku, obráťte sa priamo na Vašu predajňu nábytku.

SLO Naše direktna usluga za montažo obzaveždanja
Če vam manjka kakšno delce, lahko to servišno kartico pošljete po e-pošti direktno na spodnji naslov. Po tej poti vam lahko pošljemo samo oškodovane. Če želite reklamirati kakšen drug del pohištva, se obrnite na prodajalno na vašo trgovino pohištva.

RO Servisul nostru direct pentru dotarea
În cazul în care vă lipsește o piesă de mobilier, puteți să trimiteți direct această card de service prin e-mail la adresa de mai jos. Noi nu putem trimite decât piese de mobilier de către această adresă. Dacă aveți o altă reclamație referitoare la piesa de mobilier, atunci vă rugăm să vă adresați direct la magazinul dvs. de mobilier.

RUS Прямая услуга для поставки фурнитуры
Если оказалось, что Вам не хватает того или иного элемента фурнитуры, Вы можете отправить сервисную карту по адресу непосредственно на наш электронный адрес электронной почты. Однако, только образом мы можем предоставить только фурнитуру. Если же у Вас возникнут иные претензии относительно приобретенной мебели, пожалуйста, обращайтесь по адресу непосредственно в магазин, осуществляющий продажу.

S Utwór: Drukownice i.r. Besch: Legale
Om du saknar en beslaggad del kan du skicka detta servicekort direkt till e-postadressen som anges nedan. Men vi kan endast skicka delar om de är skadade på detta sätt. Om du vill reklamera din möbel av en annan anledning måste du kontakta ditt möbelföretag direkt.

ES Nuestro servicio directo para accesorios
Si le falta algún accesorio, puede enviar esta tarjeta de servicio directamente a la siguiente dirección. No obstante, por este método solo podemos enviar accesorios. Si tiene alguna otra objeción sobre su mueble, consulte directamente con su mueblería.

TR Doğrudan hizmet için donatılar
Bir donatıda e-halkası bu servis kartını doğrudan aşağıdaki buruna e-halkası doğrudan mail ya da biliniriz. Sadece bu yolla donatılar gönderilebilir. Meblehinize başka şikayetleriniz varsa lütfen doğrudan mobilya satıcınıza danışın.

HC 55	x1	1500	200	15	1/1
HC 56	x1	1400	169	28	1/1

RAVENNA 71

D
GB
CZ

Unser Dienstservice für Beschädigte
Sollten Ihnen ein Beschädigtes fehlen, können Sie diese Servicekarte direkt an die untenstehende Adresse mailen. Wir können a landing nur Beschädigte auf diesem Wege verschicken. Sollten Sie eine andere Beschreibung an Ihrem Möbelstück haben, so wenden sie sich bitte direkt an Ihr Möbelhaus.

Our direct order service for fitting
If a fitting part is missing, you can e-mail this service card directly to the address below. However, we can only send fitting parts in this way. If you have any other cause for complaint concerning your item of furniture, please contact your furniture store directly.

Náše přímé služby pro kování
Chybí-li vám nějaký díl z kování, můžete tuto službu i tento adresát e-mailem přímo na náš ústřední adresu. Tuto částku však můžeme poslat jen díky kování. Pokud byste reklamovali jiný díl nábytku, obraťte se přímo na svého prodejce nábytku.

Service client en ligne de montage
Si vous manquez une ferrure, veuillez e-mailer directement la présente carte ainsi que l'adresse e-mail indiquée ci-dessous. Cependant, ceci nous permet uniquement d'envoyer des ferrures. Pour tout autre type de réclamation concernant votre meuble, veuillez contacter directement votre magasin d'ameublement.

Il nostro servizio diretto per i condire della ferramenta
Qualora Vi dovesse mancare un pezzo di ferramenta, allora Vi preghiamo di inviare questa carta di servizio insieme al presente all'indirizzo sotto indicato. Possiamo inviare i pezzi di ferramenta solamente per mezzo di questo procedimento. Qualora dovete avere qualche altra reclamo in merito al mobile, allora Vi preghiamo di rivolgerVi direttamente al Vostro Negozio di mobili.

Наша служба помощи по мебели
Ако ви липне нешто од железарија, потпишите нешто малку саржан картата и ја испратете на е-маил адреса, нavedена подолу. По тоа начин можеме да доставиме само железарија ковањето од мебелот. Ако уште имате други причини по мебелот, Ве советуваме да се обвршете директно на Вашиот продавач, од којто сте купувале мебелот.

BG

Onze directservice voor de montage
Wanneer we een onderdeel ontbreekt, kunt u deze servicekaart direct aan ons toesturen die u meegeleverd is. Wij kunnen lange deze weg echter alleen beschadigden verzenden. Mocht u een ander probleem aan uw meubel hebben, verzaken wij u contact op te nemen met uw meubelwinkler.

NL

Nasz bezpośredni serwis części montażowych
Jeżeli brakuje części koniecznych do montażu, prosimy o przesłanie nam niniejszej karty wraz z adresem e-mailowym. W ten sposób możemy przesyłać wyłącznie części montażowe. W przypadku innych reklamacji dotyczących mebla, prosimy zgłaszać się do sklepu meblowego, w którym został dokonany zakup.

PL

Service zaokona
U slučaju da nedostaje neki od dijelova molimo vas da nas dalje nekad adresu pošaljete ovaj servisi obrazac. Na ovaj način mogu se dostaviti samo okona. U slučaju da imate dodatne prigovore molimo vas komad nampoljajati molimo vas da se obratite izravno trgovini na mjestu gdje je bilo kupljen.

HR

Direktív szolgáltatásunk a csavarokhoz
Ha hiányzik egy csavar, azt a kérést közvetlenül e-közvetítéssel az alábbi e-mail címre. Azonban csak csavarokat tudunk így küldeni. Amennyiben más okból reklamálna a fém bútorneművel kapcsolatban, forduljon közvetlenül a bolti eladóhoz.

HU

Náš přímý servis pro čisti kování
Ak by Vám chýbala niekajaká časť kování, môžete poslať túto službu i tento adresát e-mailem na náš ústrední adresu. Tuto částku však můžeme poslat jen díky kování. Pokud byste reklamovali jiný díl nábytku, obraťte se přímo na Vašho prodejce nábytku.

SK

Náše direkte service voor de montage
Als u een onderdeel ontbreekt, kunt u deze servicekaart direct aan ons toesturen die u meegeleverd is. Wij kunnen lange deze weg echter alleen beschadigden verzenden. Mocht u een ander probleem aan uw meubel hebben, verzaken wij u contact op te nemen met uw meubelwinkler.

SLO

Service client en ligne de montage
Si vous manquez une ferrure, veuillez e-mailer directement la présente carte ainsi que l'adresse e-mail indiquée ci-dessous. Cependant, ceci nous permet uniquement d'envoyer des ferrures. Pour tout autre type de réclamation concernant votre meuble, veuillez contacter directement votre magasin d'ameublement.

RO

Наша служба помощи по мебели
Ако ви липне нешто од железарија, потпишите нешто малку саржан картата и ја испратете на е-маил адреса, нavedена подолу. По тоа начин можеме да доставиме само железарија ковањето од мебелот. Ако уште имате други причини по мебелот, Ве советуваме да се обвршете директно на Вашиот продавач, од којто сте купувале мебелот.

RUS

Unser Dienstservice für Beschädigte
Sollten Ihnen ein Beschädigtes fehlen, können Sie diese Servicekarte direkt an die untenstehende Adresse mailen. Wir können a landing nur Beschädigte auf diesem Wege verschicken. Sollten Sie eine andere Beschreibung an Ihrem Möbelstück haben, so wenden sie sich bitte direkt an Ihr Möbelhaus.

S

Nuestro servicio directo para accesorios
Si le falta algún accesorio, puede enviarnos este tarjeta de servicio de reclamos a la siguiente dirección. No obstante, por este medio solo podemos enviar accesorios. Si tiene alguna otra objeción sobre su mueble, consulte directamente con su mueblería.

ES

Direktív szolgáltatásunk a csavarokhoz
Ha hiányzik egy csavar, azt a kérést közvetlenül e-közvetítéssel az alábbi e-mail címre. Azonban csak csavarokat tudunk így küldeni. Amennyiben más okból reklamálna a fém bútorneművel kapcsolatban, forduljon közvetlenül a bolti eladóhoz.

TR

HCZ10 8704



X...

HCK2 1311



7x70 X...

HCT10 1274
8281

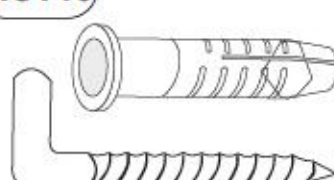

X...

HCL15 6463



X...

HCE6 1007



ES 6x9,5 X...

