

- | | |
|----------------------------------|------------------------------|
| (D) Montageanleitung | (FR) Notice de montage |
| (NL) Handleiding voor de montage | (CZ) Montážní návod |
| (HU) Szerelési útmutató | (TR) Montaj talimatı |
| (GB) Assembly instructions | (IT) Istruzioni di montaggio |
| (PL) Instrukcja montażu | (SK) Návod na montáž |
| (RO) Instrucțiuni de montaj | (RU) Инструкция по монтажу |

**Service • Assistenza • Dienstverlening • Serwis
Servis • Szerviz • Сервисная служба**

Name • Nom • Nome • Naam •
Nazwa • Jméno • Názov • Név •
Denimire • Isim • Название

Nr. • No. • N° • Номер • Č • Sz

Тур • Туре • Тір • Тірус • Тіро •
Тип

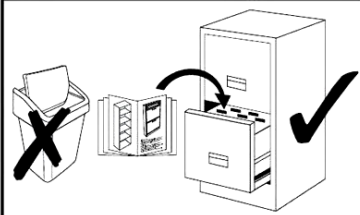
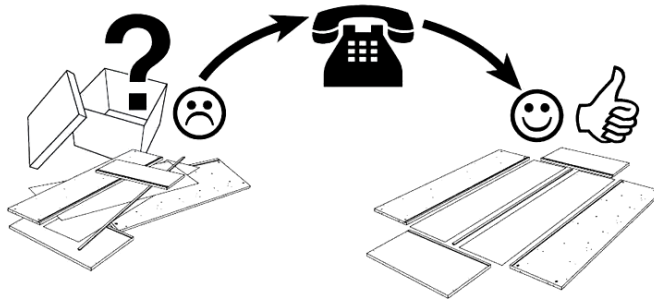

1	1x	ca. 1350 x 330 mm	9	4x	ca. 757 x 172 mm
2	1x	ca. 1331 x 680 mm	10	4x	ca. 707 x 307 mm
3	1x	ca. 1319 x 330 mm	11-L	4x	ca. 310 x 88 mm
4	1x	ca. 760 x 330 mm	11-M	4x	ca. 695 x 88 mm
5	1x	ca. 667 x 315 mm	11-R	4x	ca. 310 x 88 mm
6	1x	ca. 667 x 315 mm	12	1x	ca. 1319 x 77 mm
7	2x	ca. 728 x 92 mm	13	1x	ca. 698 x 377 mm
8	1x	ca. 760 x 330 mm	14	1x	ca. 196 x 310 mm
			15	1x	ca. 365 x 300 mm
			16	1x	ca. 1350 x 330 mm
			17	3x	ca. 310 x 80 mm

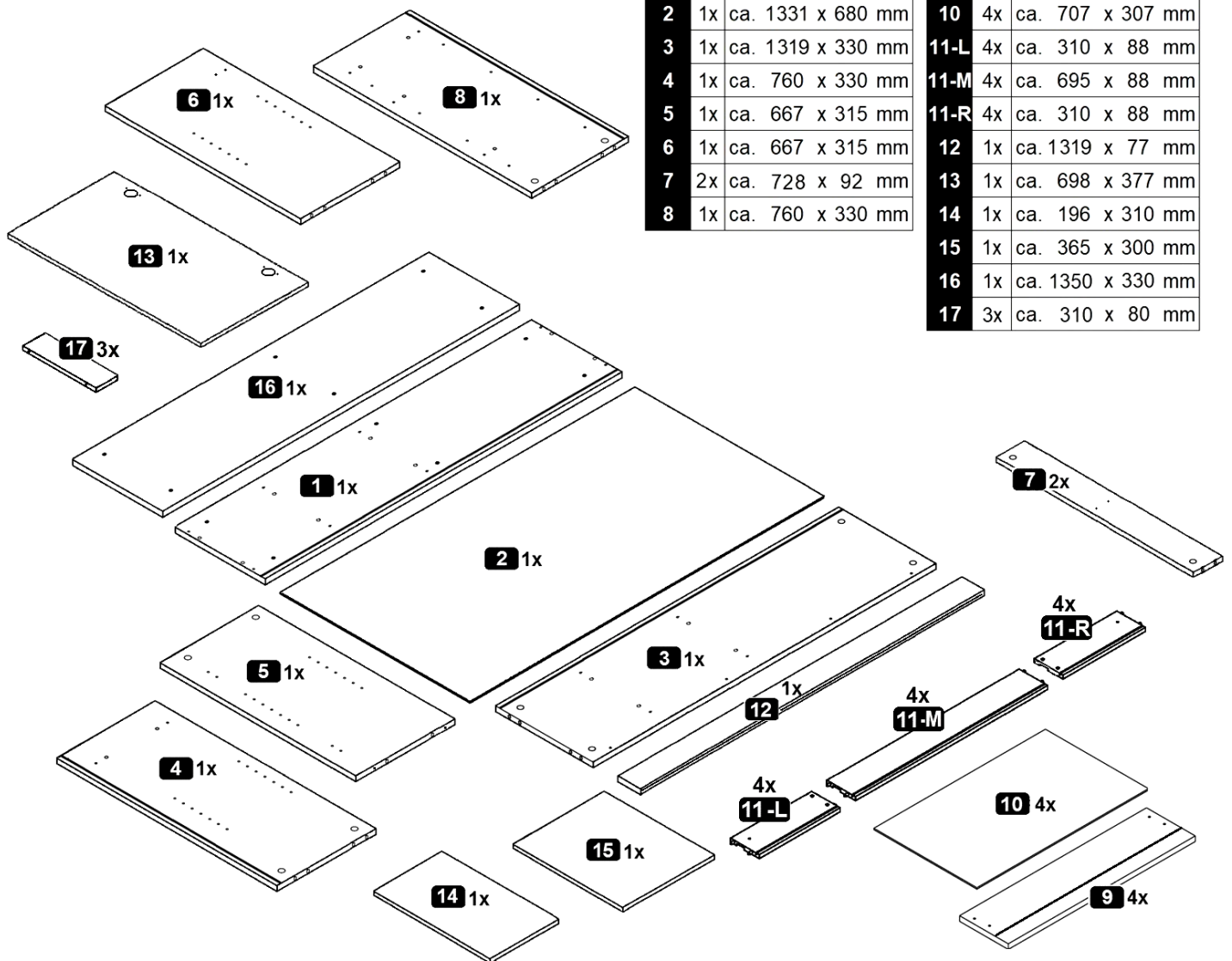

A	8,0 x 30 mm	B	16x	C	16x	D	3,5x9,5mm	E	5,0 x 50 mm	F	2x	G	3,0 x 40 mm	4x
H	8x	I	6,3 x 13 mm	J	M4 x 9 mm	K	8x	L	h=2	M	Ø35 Kr.0	N	2,7 x 20 mm	8x



1

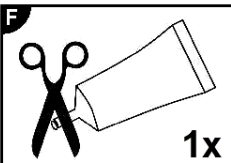
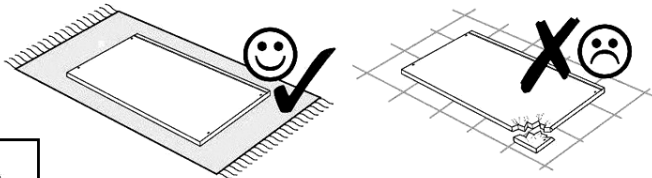

- D Leim
- GB Glue
- FR Colle
- IT Colla
- NL Lijm
- PL Klej
- CZ Lepidlo
- SK Glej
- HU Enyv
- RO Adeziv
- TR Tutkal
- RU Клей

4x

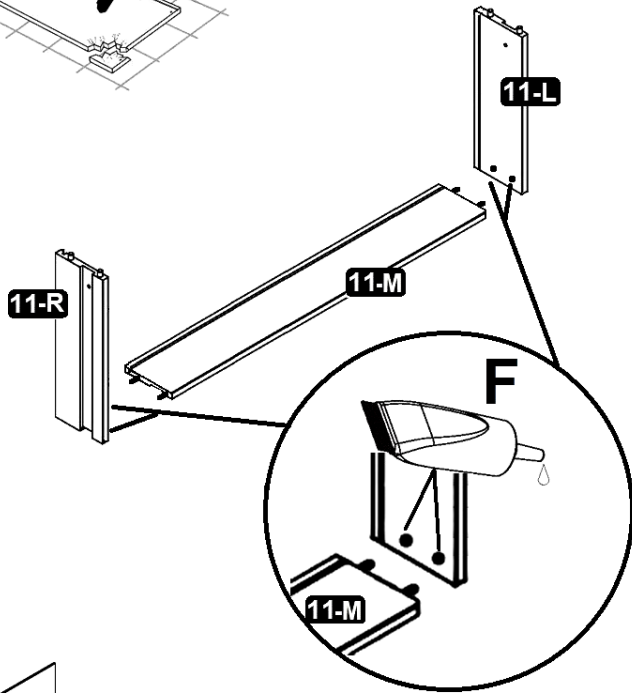

4x

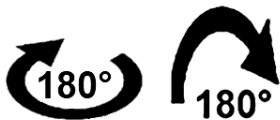
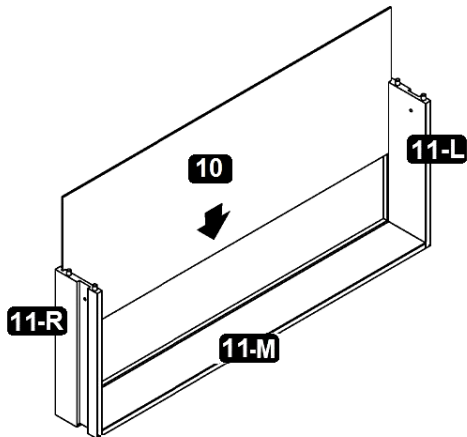

4x

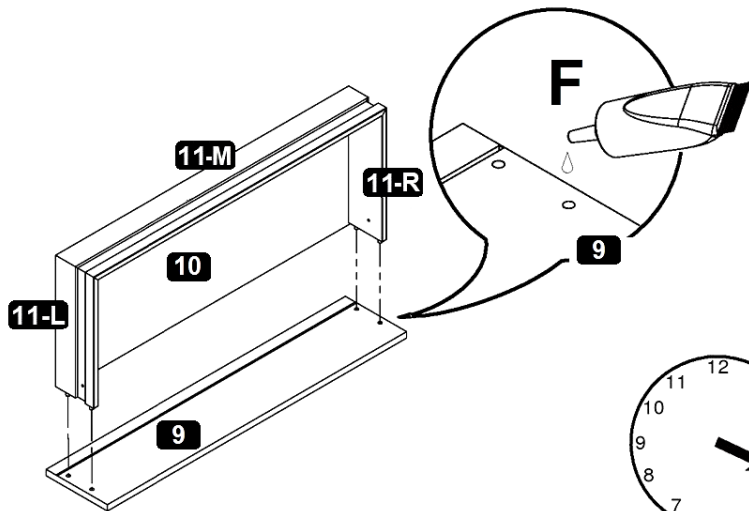

20min

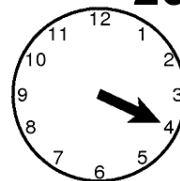

2



- A** 8,0 x 30 mm **B** 10x
- C** 4x
- E** 5,0 x 50 mm 6x

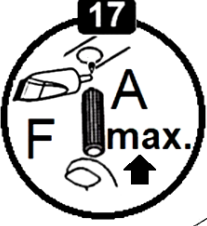
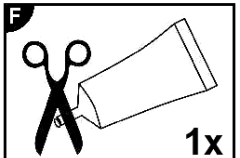
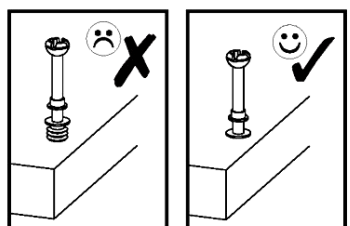
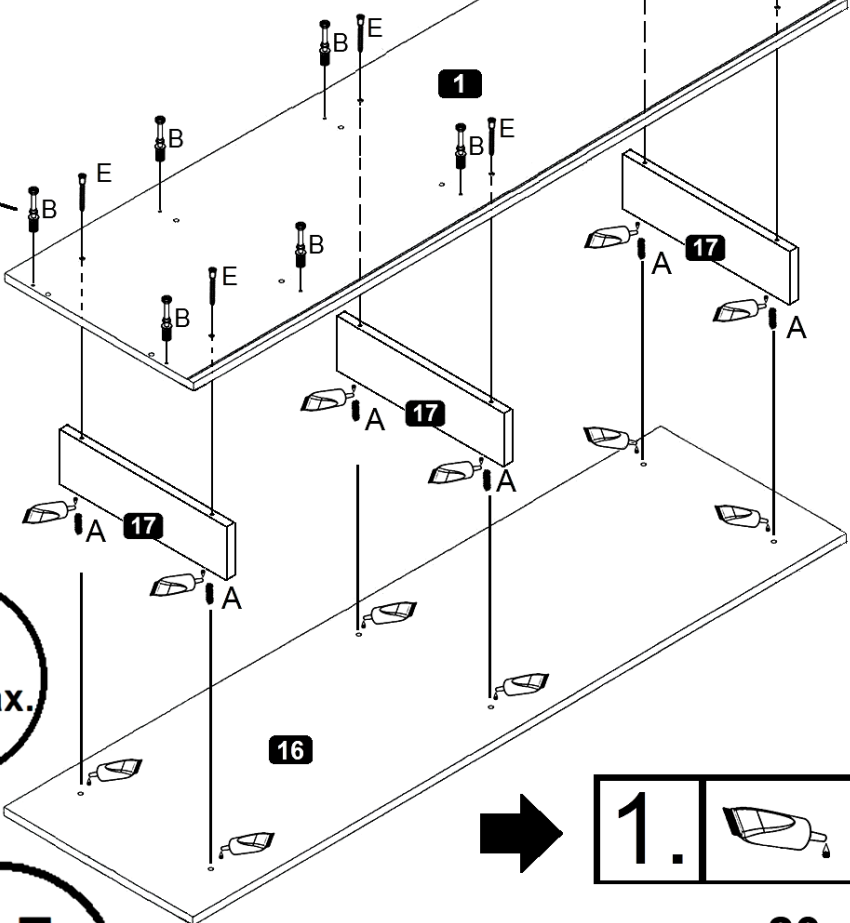
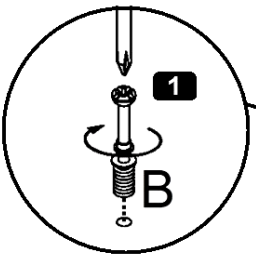
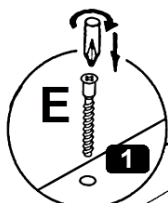



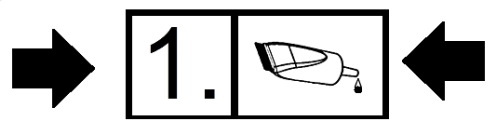
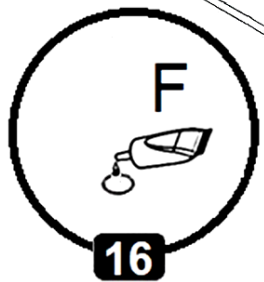

- F** Leim
- GB Glue
- FR Colle
- IT Colla
- NL Lijm
- PL Klej
- CZ Lepidlo
- SK Glej
- HU Enyv
- RO Adeziv
- TR Tutkal
- RU Клей

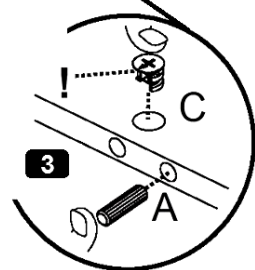
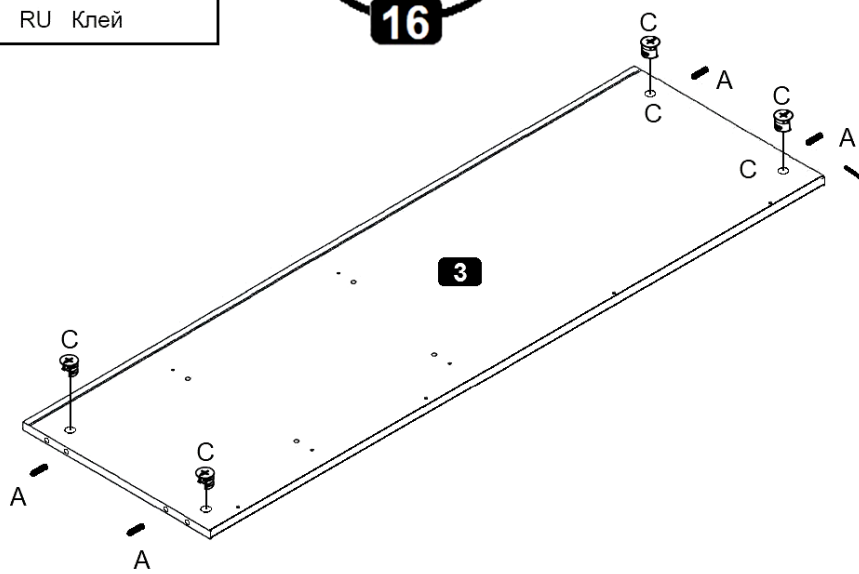
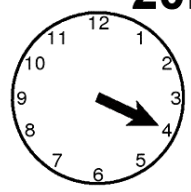

20min







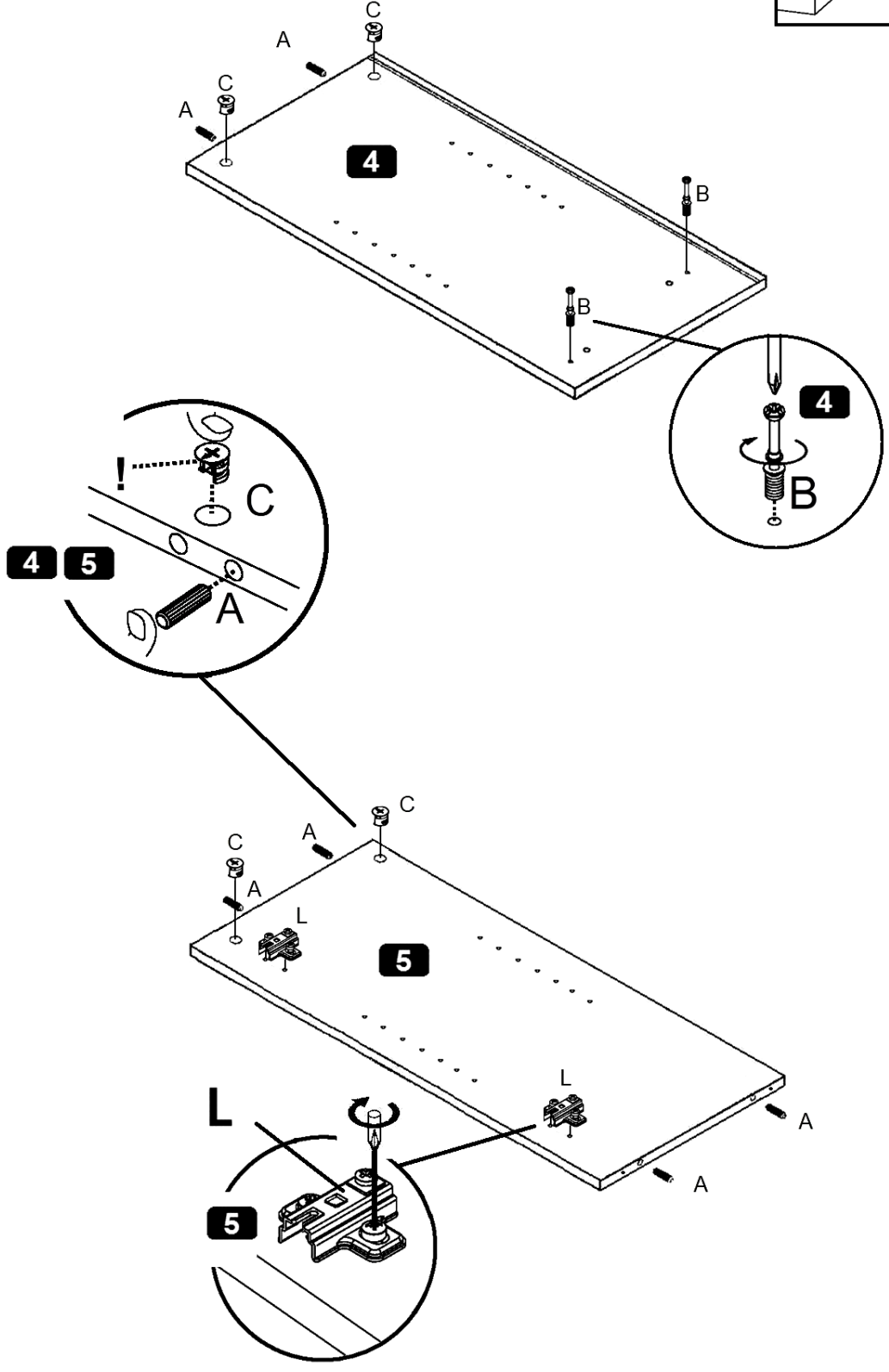
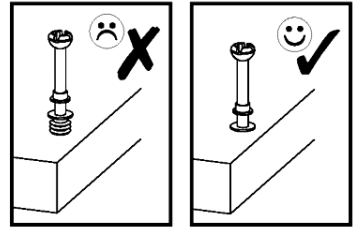
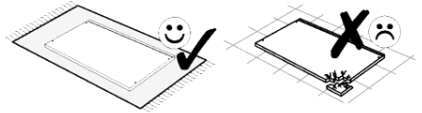

3

A 8,0 x 30 mm  6x	B  2x	C  4x	L h=2  2x
---	---	---	---

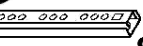

4

A 8,0 x 30 mm  10x	B  6x	C  8x	H  8x	I 6,3 x 13 mm  16x
D  3,5x9,5mm  5x				

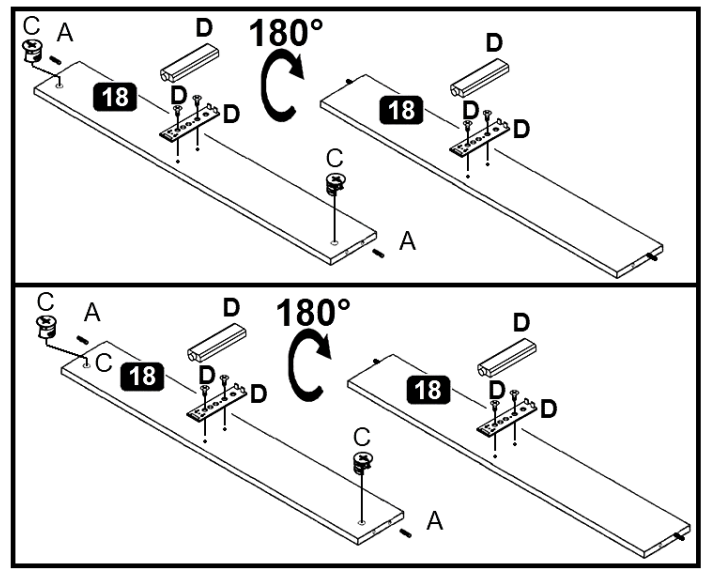
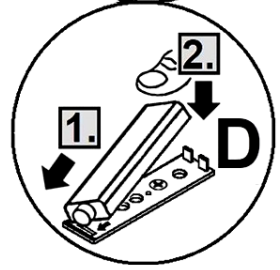
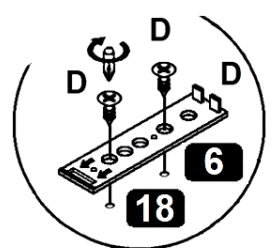
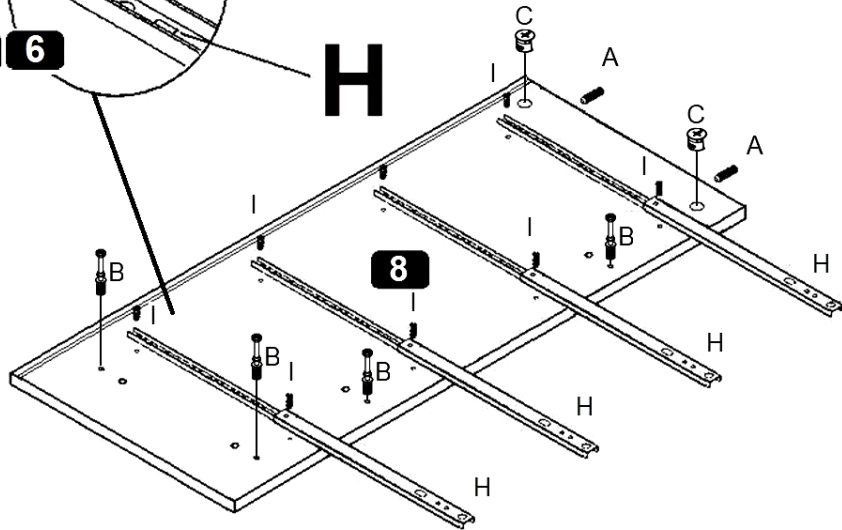
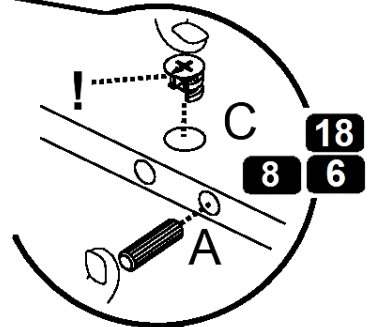
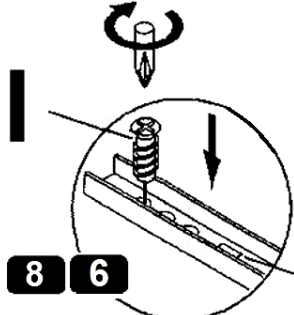
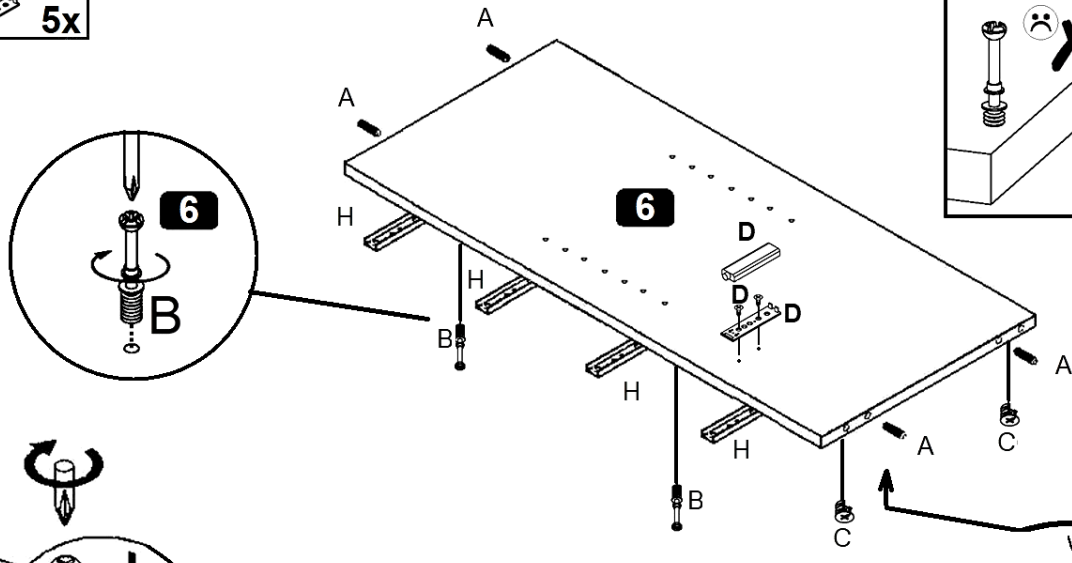
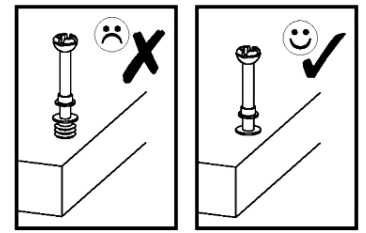
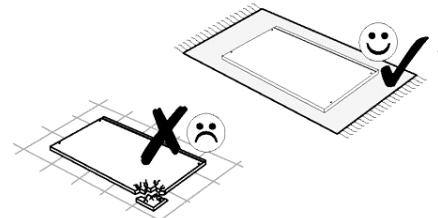

5

E 5,0 x 50 mm
4x

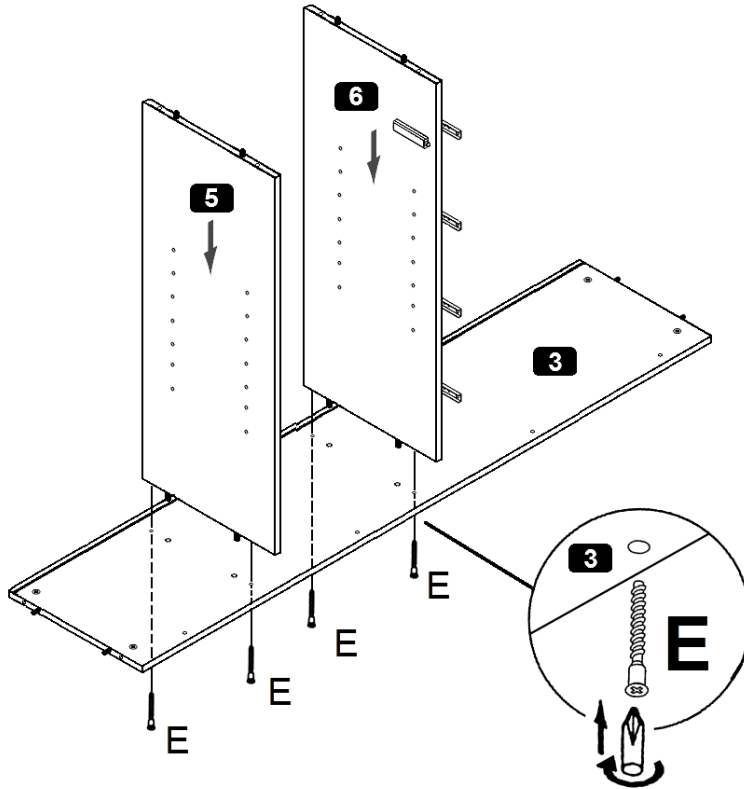

6

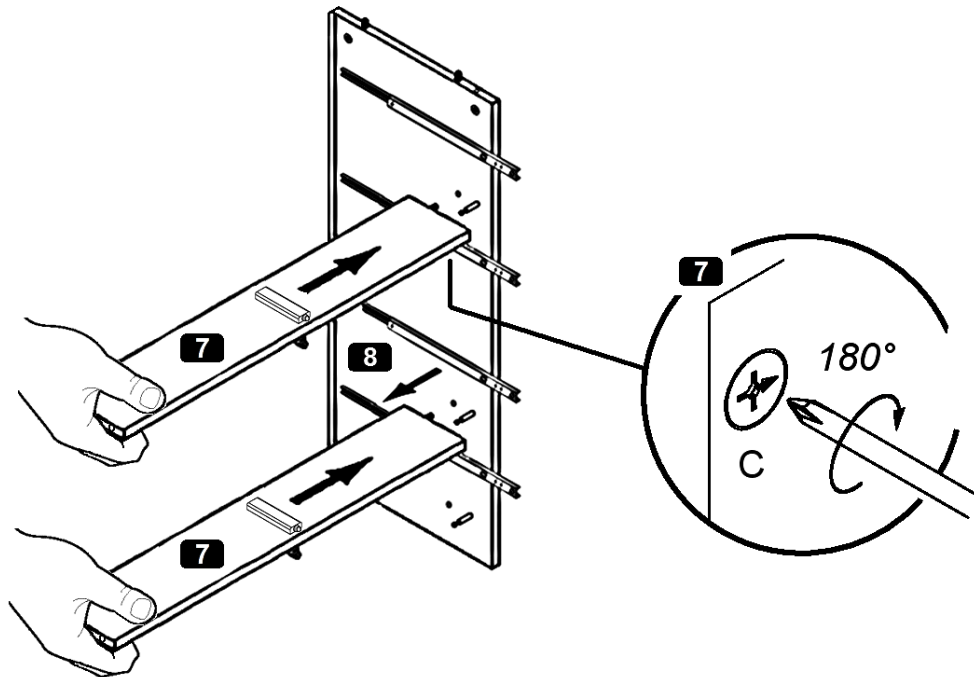

7

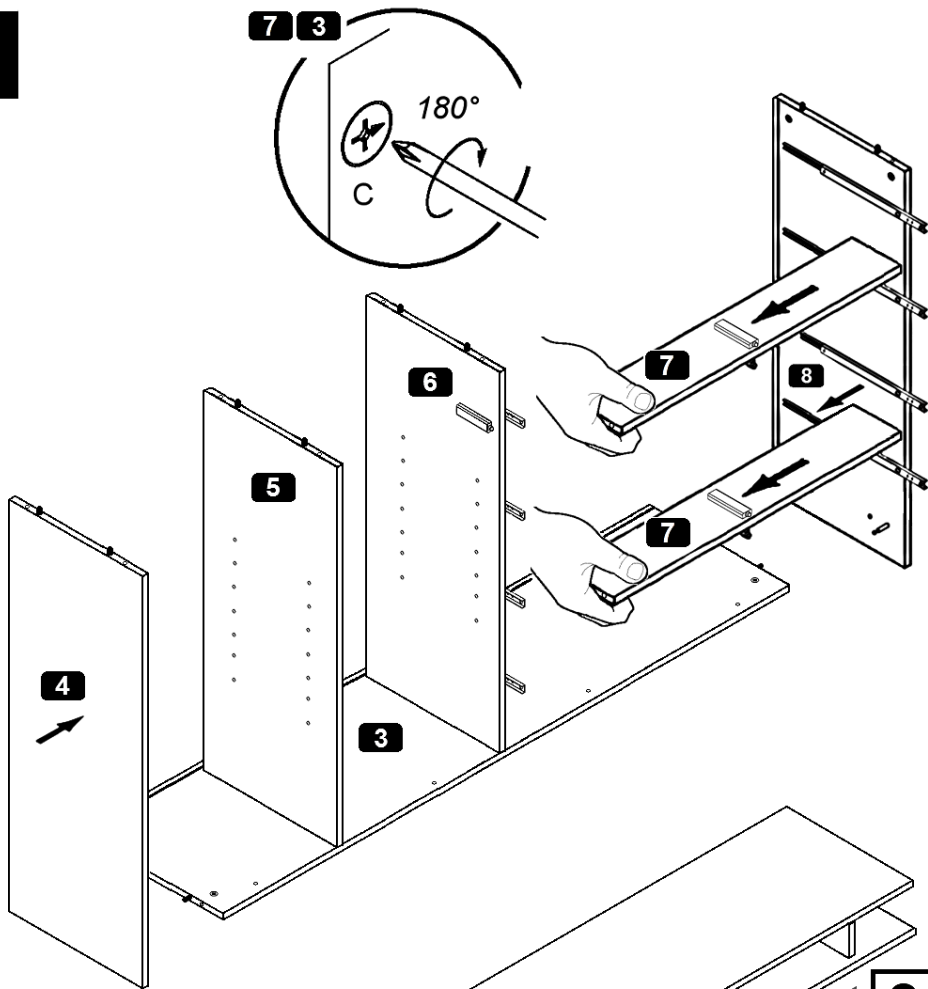

8

G 3,0 x 40 mm
4x

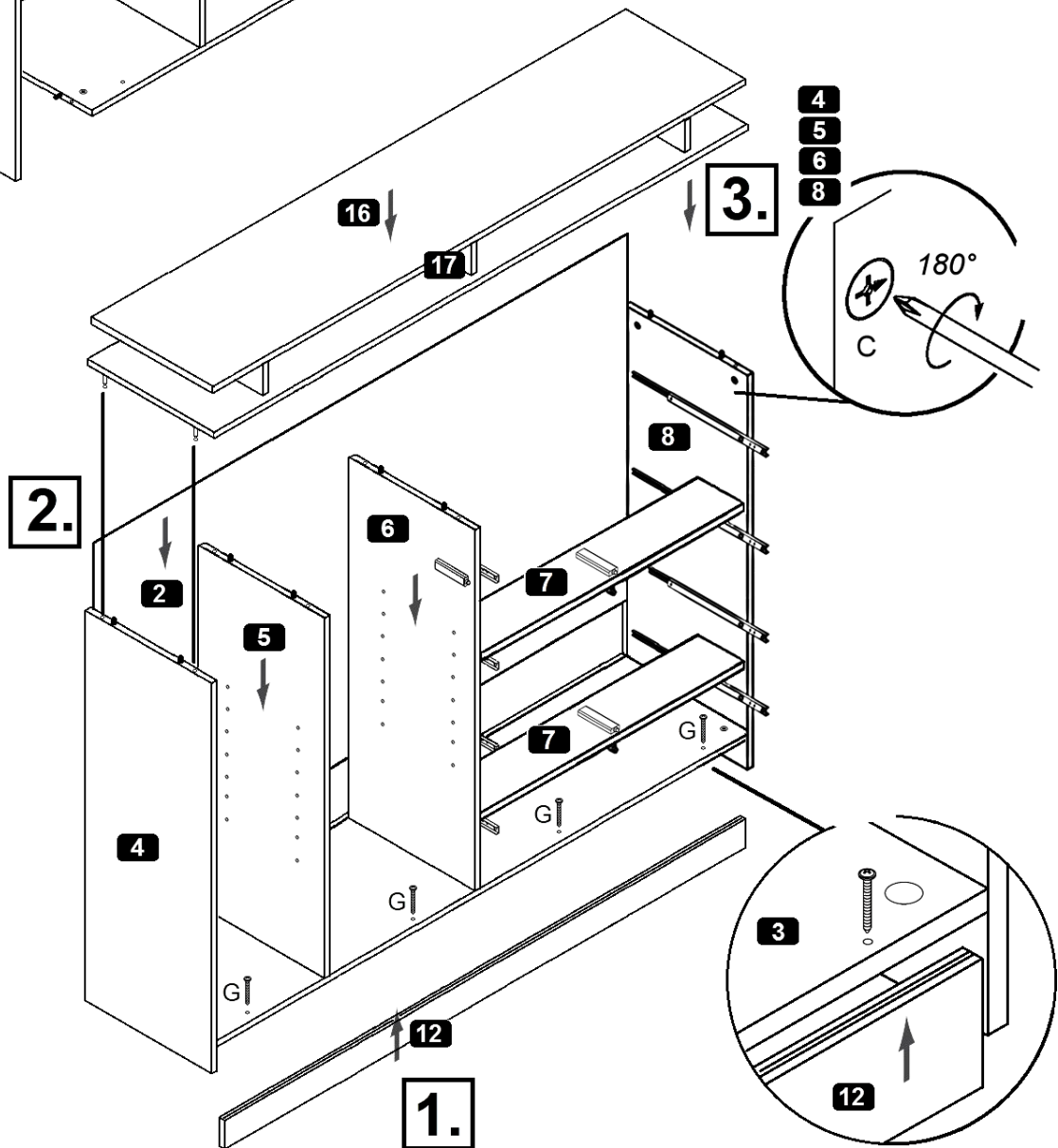

9

J	M4 x 9 mm	8x
K		8x
N	2,7 x 20 mm	8x

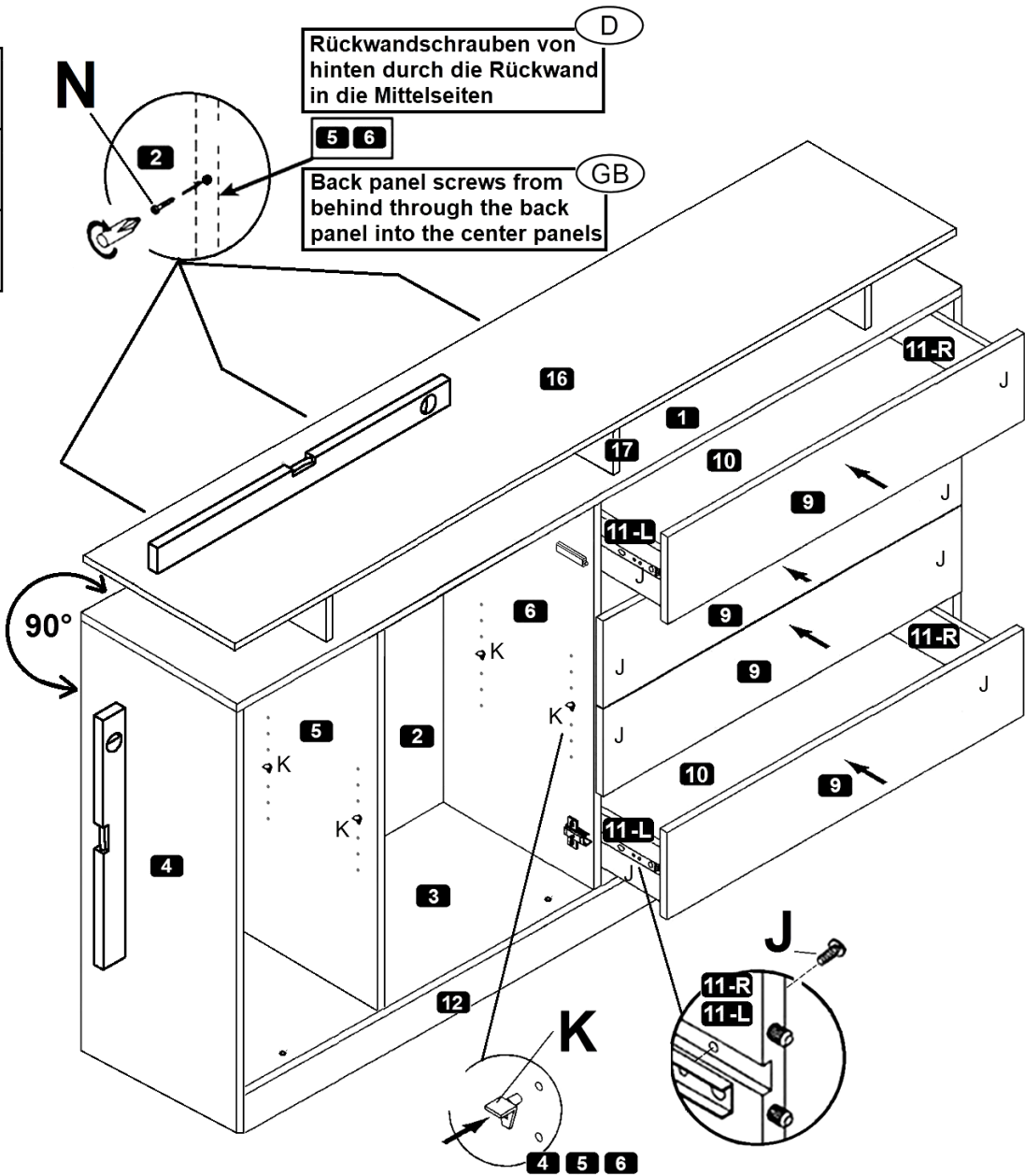

10

M	Ø35 Kr.0	2x
	3,5x13 mm	

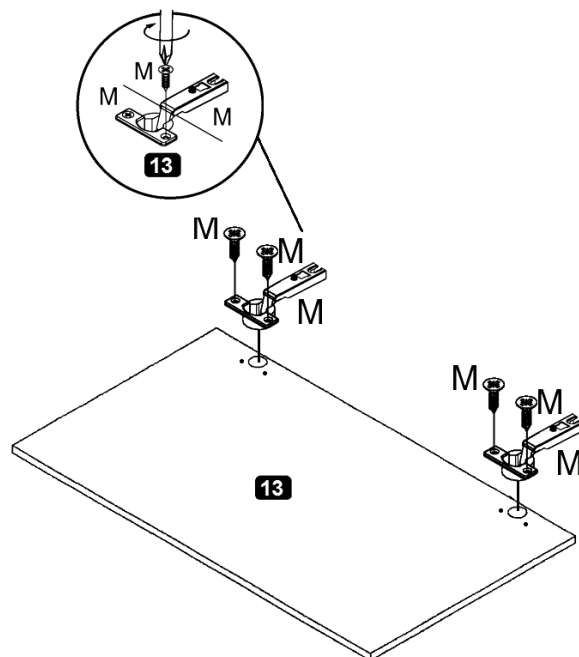

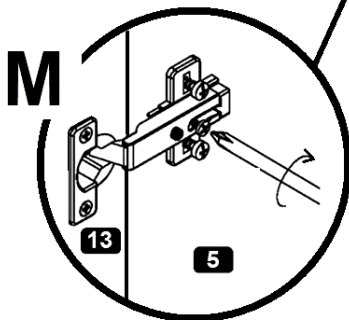
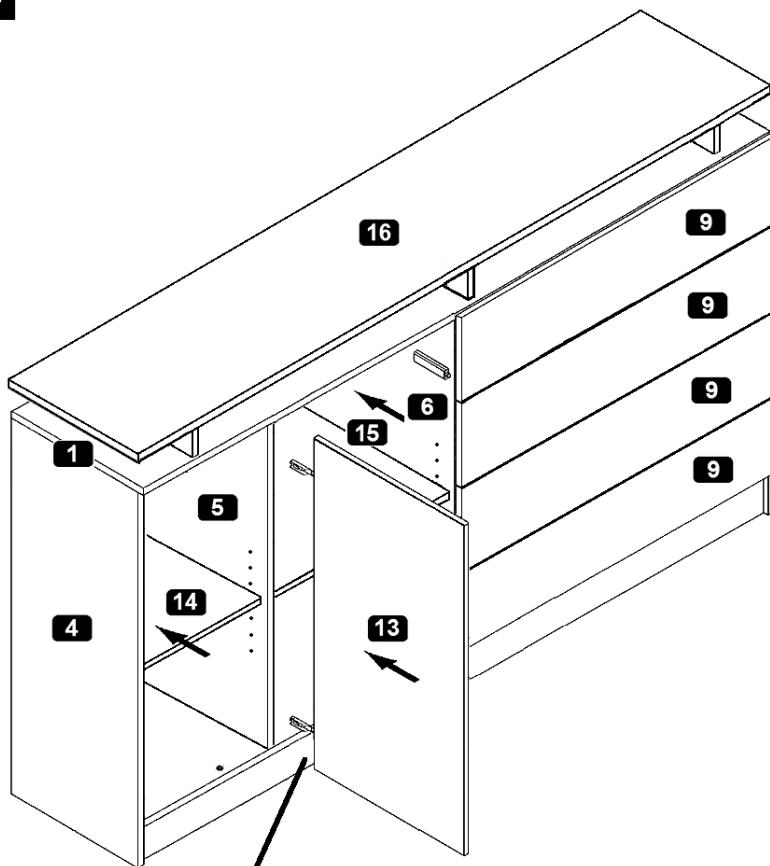

➔ 12/12

- (D) Push-To-Open einstellen
- (GB) Adjusting the Push-To-Open
- (FR) Régler les Push-To-Open
- (IT) Sistemare Push-To-Open
- (NL) Push-To-Open instellen
- (PL) Nastawić Push-To-Open
- (CZ) Vyrovnajte Push-To-Open
- (RO) Nastavenie Push-To-Open
- (HU) Állítsa be az Push-To-Open
- (SK) Reglare Push-To-Open
- (TR) Push-To-Open ayarlanması
- (RU) Регулировка Push-To-Open

➔ 11/12

- (D) Türen einstellen
(Scharniere justieren)
- (GB) Adjusting the doors
(adjusting the hinges)
- (FR) Régler les portes
(ajuster les charnières)
- (IT) Sistemare le porte
(regolare le cerniere)
- (NL) Deuren instellen
(scharnieren afstellen)

- (PL) Nastawić drzwi
(wyregulować zawiasy)
- (CZ) Vyrovnajte dvířka
(seřid'te závěsy)
- (RO) Nastavenie dverí
(nastavenie závesov)
- (HU) Állítsa be az ajtókat
(állítsa be a zsanérokot)
- (SK) Reglare uši
(ajustare balamale)
- (TR) Kapıların ayarlanması
(menteşelerin seviye ayarı)
- (RU) Регулировка дверей
(регулировка шарнира)

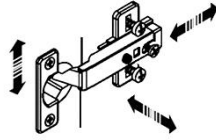

(D) Türen einstellen
(Scharniere justieren)

(GB) Adjusting the doors
(adjusting the hinges)

(FR) Régler les portes
(ajuster les charnières)

(IT) Sistemare le porte
(regolare le cerniere)

(NL) Deuren instellen
(scharnieren afstellen)

(PL) Nastawić drzwi
(wyregulować zawiasy)

(CZ) Vyrovnajte dvířka
(seřid'ťe závěsy)

(RO) Nastavenie dverí
(nastavenie závesov)

(HU) Állítsa be az ajtókat
(állítsa be a zsanérokát)

(SK) Reglare uši
(ajustare balamale)

(TR) Kapıların ayarlanması
(menteşelerin seviye ayarı)

(RU) Регулировка дверей
(регулировка шарнира)

